



**FCC 47 CFR PART 15 SUBPART C
ISED RSS-247 ISSUE 1**

LIMITED MODULAR CERTIFICATION TEST REPORT

FOR

WiFi Limited Module

MODEL NUMBER: MW300

**FCC ID: HBW8522
IC: 2666A-8522**

REPORT NUMBER: 11522702A

ISSUE DATE: January 31, 2017

Prepared for
**CHAMBERLAIN GROUP INC.
300 Windsor Dr.
Oak Brook, IL 60523**

Prepared by
**UL LLC
333 Pfingsten Rd.
Northbrook, IL 60062
TEL: (847) 272-8800**



NVLAP Lab code: 100414-0

Revision History

<u>Rev.</u>	<u>Issue Date</u>	<u>Revisions</u>	<u>Revised By</u>
--		Initial Issue	

TABLE OF CONTENTS

1. ATTESTATION OF TEST RESULTS	4
2. TEST METHODOLOGY	5
3. FACILITIES AND ACCREDITATION	5
4. CALIBRATION AND UNCERTAINTY	5
4.1. <i>MEASURING INSTRUMENT CALIBRATION</i>	5
4.2. <i>SAMPLE CALCULATION</i>	5
4.3. <i>MEASUREMENT UNCERTAINTY</i>	5
5. EQUIPMENT UNDER TEST	6
5.1. <i>DESCRIPTION OF EUT</i>	6
5.2. <i>MAXIMUM OUTPUT POWER</i>	6
5.3. <i>DESCRIPTION OF AVAILABLE ANTENNAS</i>	7
5.4. <i>SOFTWARE AND FIRMWARE</i>	7
5.5. <i>WORST-CASE CONFIGURATION AND MODE</i>	8
5.6. <i>DESCRIPTION OF TEST SETUP</i>	9
6. TEST AND MEASUREMENT EQUIPMENT	11
7. MEASUREMENT METHODS	12
8. ANTENNA PORT TEST RESULTS	13
8.1. <i>ON TIME AND DUTY CYCLE</i>	13
8.2. <i>6 dB BANDWIDTH and 99% OBW</i>	17
8.3. <i>OUTPUT POWER</i>	24
8.4. <i>POWER SPECTRAL DENSITY</i>	32
8.5. <i>CONDUCTED OUT-OF-BAND EMISSIONS</i>	39
9.2. <i>RADIATED TRANSMITTER ABOVE 1 GHz</i>	56
9.2.1. <i>TX ABOVE 1 GHz 802.11b MODE IN THE 2.4 GHz BAND</i>	56
9.2.2. <i>TX ABOVE 1 GHz 802.11g MODE IN THE 2.4 GHz BAND</i>	66
9.2.3. <i>TX ABOVE 1 GHz 802.11n HT20 MODE IN THE 2.4 GHz BAND</i>	76
9.3. <i>RADIATED BELOW 1 GHz</i>	86
9.3.1. <i>SPURIOUS EMISSIONS 9kHz TO 30 MHz 802.11b</i>	86
9.3.2. <i>SPURIOUS EMISSIONS 9kHz TO 30 MHz 802.11g</i>	87
9.3.3. <i>SPURIOUS EMISSIONS 9kHz TO 30 MHz 802.11n</i>	88
9.3.4. <i>SPURIOUS EMISSIONS 9kHz TO 30 MHz Open Field Correlation Data</i>	89
9.3.6. <i>SPURIOUS EMISSIONS 30 TO 1000 MHz for 802.11b</i>	90
9.3.7. <i>SPURIOUS EMISSIONS 30 TO 1000 MHz for 802.11g</i>	96
9.3.8. <i>SPURIOUS EMISSIONS 30 TO 1000 MHz for 802.11n</i>	102
10. AC POWER LINE CONDUCTED EMISSIONS	108
11. SETUP PHOTOS	115

1. ATTESTATION OF TEST RESULTS

COMPANY NAME: CHAMBERLAIN GROUP INC.
300 Windsor Dr.
Oak Brook, IL 60523

EUT DESCRIPTION: LIMITED WIFI MODULE

MODEL: MW300

SERIAL NUMBER: non-serialized

DATE TESTED: November 21, 2016 – December 20, 2016

APPLICABLE STANDARDS	
STANDARD	TEST RESULTS
CFR 47 Part 15 Subpart C	Pass
ISED RSS-247, Issue 1	Pass
ISED RSS-GEN Issue 4	Pass

UL LLC tested the above equipment in accordance with the requirements set forth in the above standards. All indications of Pass/Fail in this report are opinions expressed by UL LLC based on interpretations and/or observations of test results. Measurement Uncertainties were not taken into account and are published for informational purposes only. The test results show that the equipment tested is capable of demonstrating compliance with the requirements as documented in this report.

Note: The results documented in this report apply only to the tested sample, under the conditions and modes of operation as described herein. This document may not be altered or revised in any way unless done so by UL LLC and all revisions are duly noted in the revisions section. Any alteration of this document not carried out by UL LLC will constitute fraud and shall nullify the document. This report must not be used by the client to claim product certification, approval, or endorsement by NVLAP, NIST, or any agency of the U.S. Government.

Approved & Released For
UL LLC By: Jeff Moser



EMC ENGINEER
UL LLC

Tested By: Bart Mucha



EMC ENGINEER
UL LLC

2. TEST METHODOLOGY

The tests documented in this report were performed in accordance with FCC CFR 47 Part 15, ANSI C63.10-2013, RSS-GEN Issue 4, RSS-247 Issue 1.

3. FACILITIES AND ACCREDITATION

The test sites and measurement facilities used to collect data are located at 333 Pfingsten Road, Northbrook, IL 60062 USA.

UL NBK is accredited by NVLAP, Laboratory Code 100414-0. The full scope of accreditation can be viewed at <http://ts.nist.gov/>

4. CALIBRATION AND UNCERTAINTY

4.1. MEASURING INSTRUMENT CALIBRATION

The measuring equipment utilized to perform the tests documented in this report has been calibrated in accordance with the manufacturer's recommendations, and is traceable to recognized national standards.

4.2. SAMPLE CALCULATION

Sample Calculations

Radiated Field Strength and Conducted Emissions data contained within this report is calculated on the following basis:

Field Strength (dBuV/m) = Meter Reading (dBuV) + AF (dB/m) - Gain (dB) + Cable Loss (dB)

Conducted Voltage (dBuV) = Meter Reading (dBuV) + Cable Loss (dB) + LISN IL (dB)

Conducted Current (dBuA) = Meter Reading (dBuV) + Cable Loss (dB) - Transducer Factor (dBohms)

4.3. MEASUREMENT UNCERTAINTY

Where relevant, the following measurement uncertainty levels have been estimated for tests performed on the apparatus:

Test	Range	Equipment	Uncertainty k=2
Radiated Emissions	30-200MHz	Bicon 10m Horz	4.27dB
Radiated Emissions	30-200MHz	Bicon 10m Vert	4.28dB
Radiated Emissions	200-1000MHz	LogP 10m Horz	3.33dB
Radiated Emissions	200-1000MHz	LogP 10m Vert	3.39dB
Radiated Emissions	30-200MHz	Bicon 3m Horz	3.30dB
Radiated Emissions	30-130MHz	Bicon 3m Vert	4.84dB
Radiated Emissions	130-200MHz	Bicon 3m Vert	4.94dB
Radiated Emissions	200-1000MHz	LogP 3m Horz	3.46dB
Radiated Emissions	200-1000MHz	LogP 3m Vert	4.98dB
Radiated Emissions	1-6GHz	Horn	5.02dB
Radiated Emissions	6-18GHz	Horn	5.34dB
Radiated Emissions	18-26GHz	Horn	6.60dB
Conducted Ant Port	30MHz-26GHz	Spectrum Analyzer	2.94

Uncertainty figures are valid to a confidence level of 95%.

5. EQUIPMENT UNDER TEST

5.1. DESCRIPTION OF EUT

The EUT is an 802.11b/g/n limited modular transceiver.

5.2. MAXIMUM OUTPUT POWER

The transmitter has a maximum conducted output power as follows:

Frequency Range (MHz)	Mode	Output Power (dBm)	Output Power (mW)
2412 - 2462	802.11b	17.34	54.20
2412 - 2462	802.11g	14.28	26.79
2412 - 2462	802.11n HT20	13.33	21.53

5.3. DESCRIPTION OF AVAILABLE ANTENNAS

The radio utilizes an trace antenna, with a maximum gain of 0 dBi.

5.4. SOFTWARE AND FIRMWARE

The firmware installed in the EUT during testing was MAW30X_MFG_14.1.36.P84

The EUT driver software installed during testing was FTDI 2.12.24

The test utility software used during testing was DutApiWiFiMW30xBridgeUart

5.5. WORST-CASE CONFIGURATION AND MODE

Power line conducted emission were performed with the EUT set to transmit at the channel with highest output power as worst-case scenario.

The fundamental of the EUT was investigated in three orthogonal orientations X,Y,Z, it was determined that Z orientation was worst-case orientation; therefore, all final radiated testing was performed with the EUT in Z orientation.

Worst-case data rates as provided by the client were:

802.11b mode: 1 Mbps

802.11g mode: 54 Mbps

802.11n HT20mode: MCS7

5.6. DESCRIPTION OF TEST SETUP

SUPPORT EQUIPMENT

Support Equipment List				
Description	Manufacturer	Model	Serial Number	FCC ID
Daughter Board	Chamberlain	-	-	-
Power Supply	Generic	-	-	-
Laptopt Computer	Generic	-	-	-
USB to 3.3V Serial	Generic	-	-	-

I/O CABLES

I/O Cable List						
Cable No	Port	# of identical ports	Connector Type	Cable Type	Cable Length (m)	Remarks
1	DC	1	soldered in	2 wire	1m	cable between power supply and daugheter board

TEST SETUP

The module is installed temporarily on a daughter board. The Daughter board provides power and data communication for programming.

SETUP DIAGRAM FOR TESTS

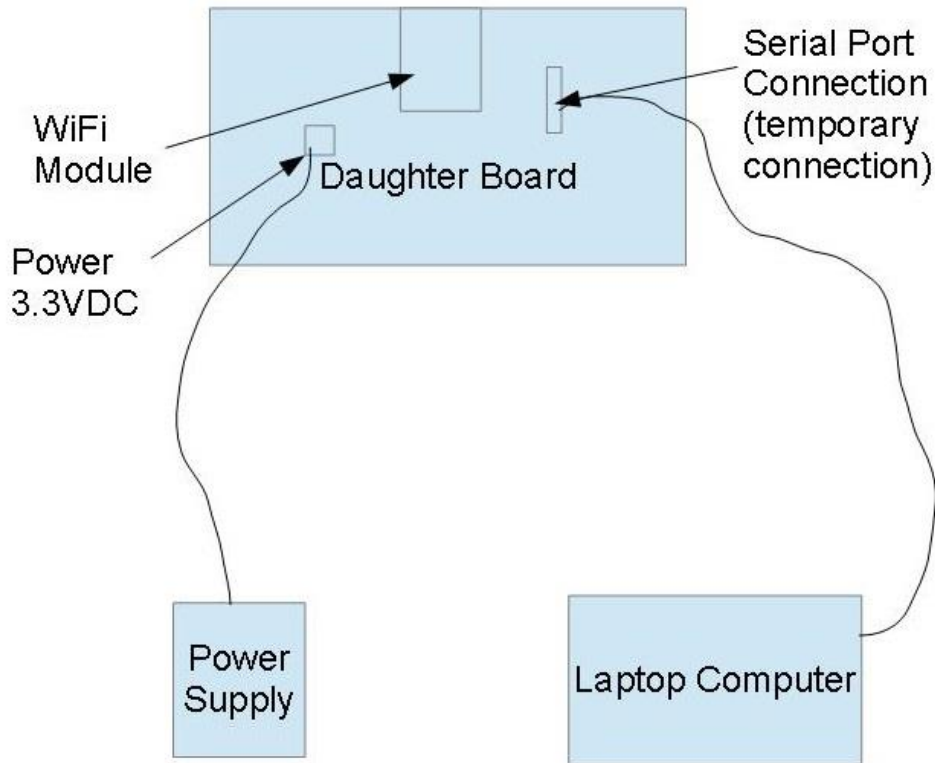

6. TEST AND MEASUREMENT EQUIPMENT

The following test and measurement equipment was utilized for the tests documented in this report:

Test Equipment List					
Description	Manufacturer	Model	Identifier	Cal Date	Cal Due
Radiated Software	UL	UL EMC	Ver 9.5, July 22, 2014		
Conducted Software	UL	UL EMC	Ver 9.5, May 17 2012		
EMI Test Receiver	Rohde & Schwarz	ESU	EMC4323	20160102	20170131
EMI Test Receiver	Rohde & Schwarz	ESCI	EMC4328	20161118	20171130
Bicon Antenna	Chase	VBA6106A	EMC4078	20151228	20161231
Log-P Antenna	Chase	UPA6109	EMC4313	20160122	20170131
Antenna Array	UL	BOMS	EMC4276	20151215	20161231
Spectrum Analyzer	Agilent	N9030A (PXA)	EMC4360	20160108	20170131

7. MEASUREMENT METHODS

6 dB BW: KDB 558074 D01 v03r05, Section 8.1.

Output Power: KDB 558074 D01 v03r05, Section 9.2.2.2.

Power Spectral Density: KDB 558074 D01 v03r05, Section 10.3.

Out-of-band emissions in non-restricted bands: KDB 558074 D01 v03r05, Section 11.0.

Out-of-band emissions in restricted bands: KDB 558074 D01 v03r05, Section 12.1.

Power line conducted Emissions: C63.10:2013, clause 6.2

8. ANTENNA PORT TEST RESULTS

8.1. ON TIME AND DUTY CYCLE

LIMITS

None; for reporting purposes only.

PROCEDURE

KDB 558074 Zero-Span Spectrum Analyzer Method.

ON TIME AND DUTY CYCLE RESULTS

Mode	ON Time B (msec)	Period (msec)	Duty Cycle x (linear)	Duty Cycle (%)	Duty Cycle Correction Factor (dB)	1/B Minimum VBW (kHz)
2.4GHz Band						
802.11b 1TX	8.627	8.687	0.993	99.31%	0.00	0.010
802.11g 1TX	100.000	100.000	1.000	100.00%	0.00	0.010
802.11n HT20 1TX	100.000	100.000	1.000	100.00%	0.00	0.010

DUTY CYCLE PLOTS

2.4 GHz BAND

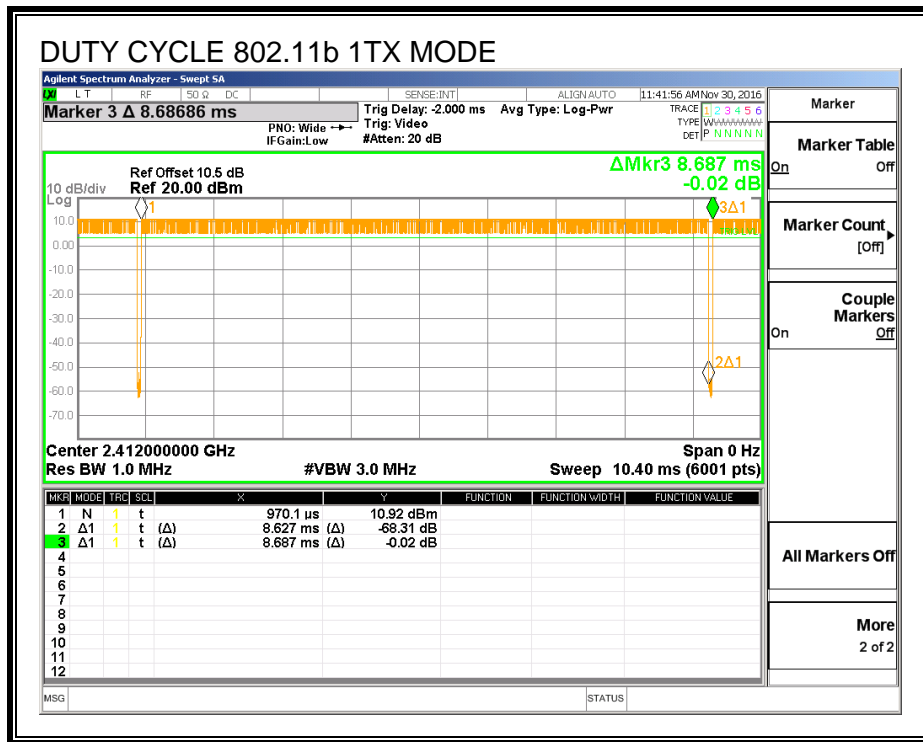

8.2. 6 dB BANDWIDTH and 99% OBW

LIMITS

FCC §15.247 (a) (2)

IC RSS-247, section 5.2

The minimum 6 dB bandwidth shall be at least 500 kHz.

RESULTS

802.11b

Channel	Frequency (MHz)	6 dB Bandwidth (MHz)	Minimum Limit (MHz)	99% OBW (MHz)
Low	2412	10.130	0.5	13.601
Mid	2437	10.130	0.5	13.685
High	2462	10.130	0.5	13.613

802.11g

Channel	Frequency (MHz)	6 dB Bandwidth (MHz)	Minimum Limit (MHz)	99% OBW (MHz)
Low	2412	16.520	0.5	16.439
Mid	2437	16.540	0.5	16.451
High	2462	16.540	0.5	16.449

802.11n20

Channel	Frequency (MHz)	6 dB Bandwidth (MHz)	Minimum Limit (MHz)	99% OBW (MHz)
Low	2412	17.810	0.5	17.662
Mid	2437	17.800	0.5	17.647
High	2462	17.820	0.5	17.704

6 dB BANDWIDTH for 802.11b

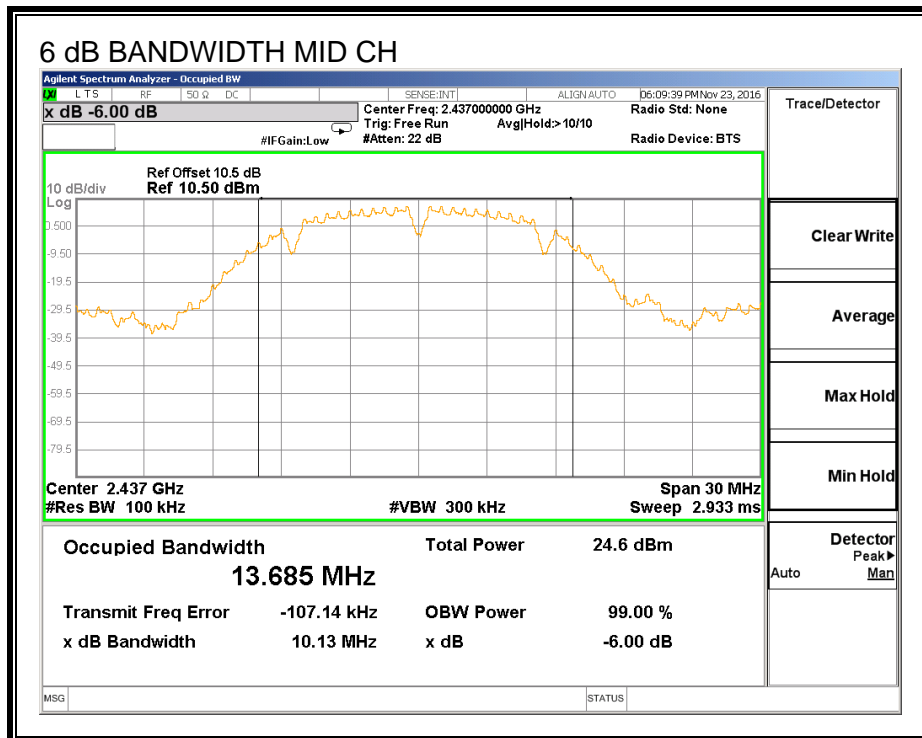
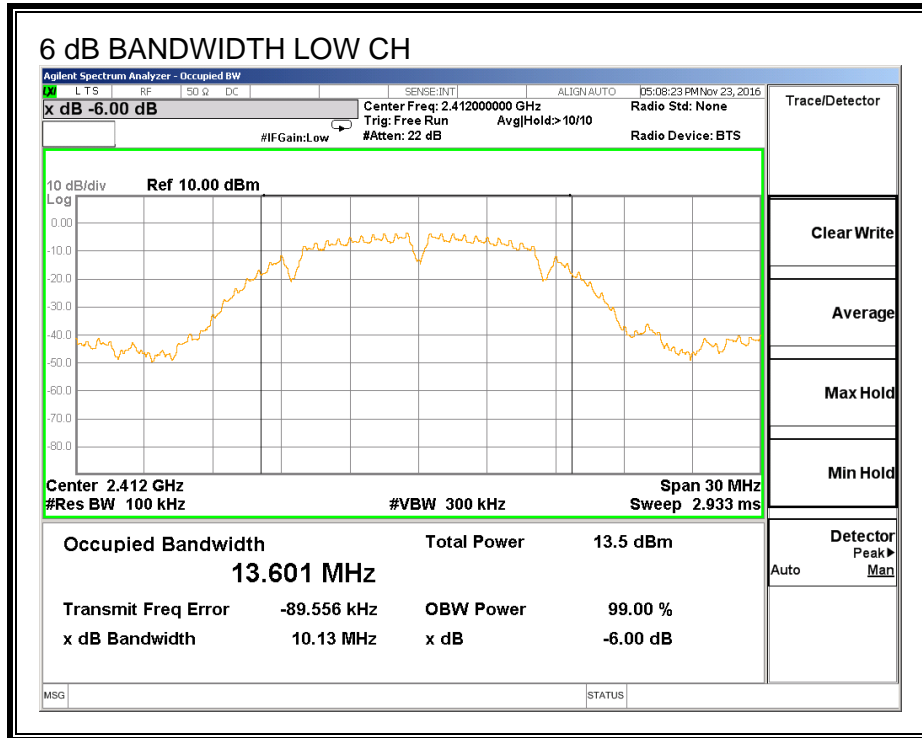

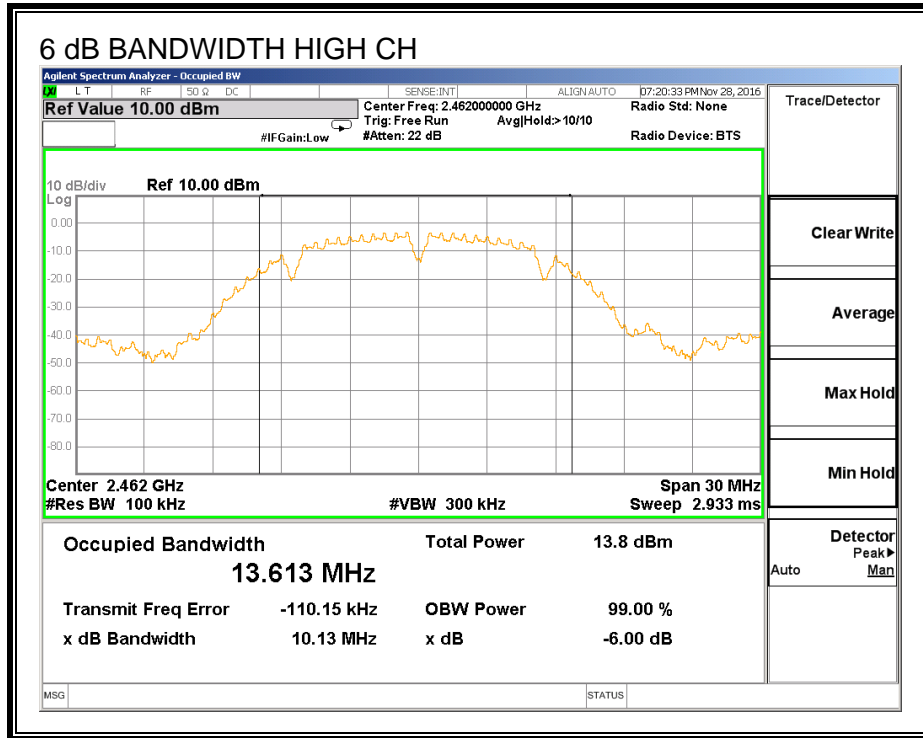

6 dB BANDWIDTH for 802.11g

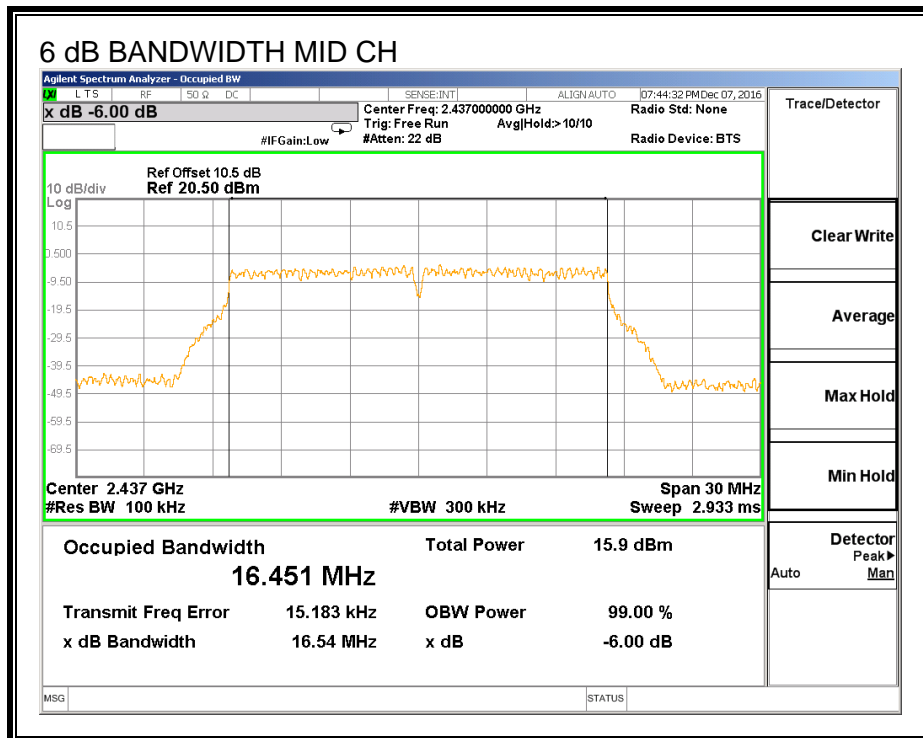
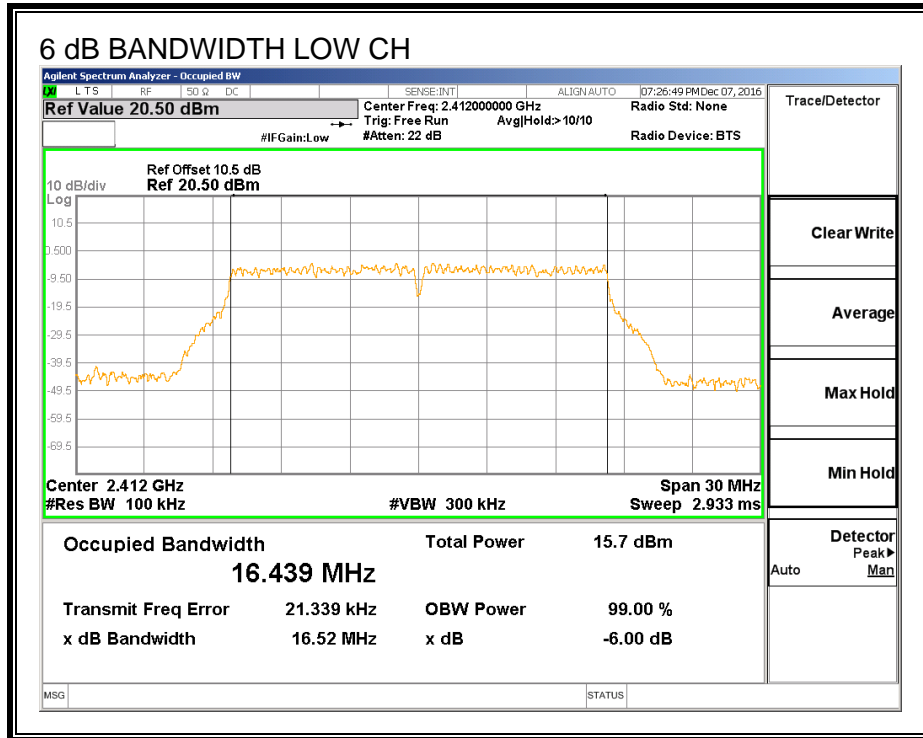

6 dB BANDWIDTH for 802.11n20

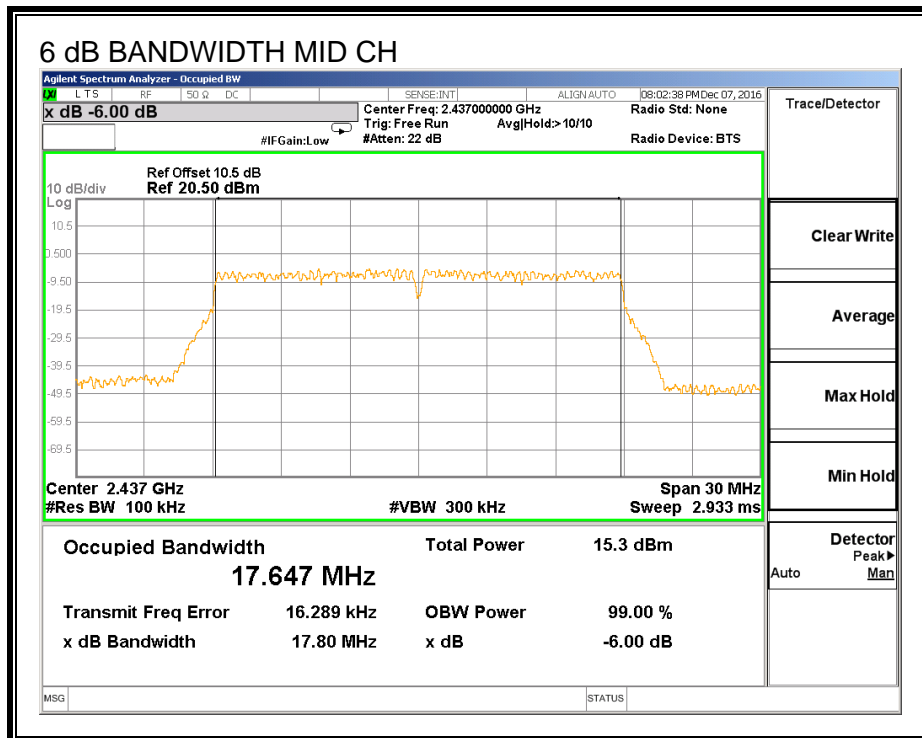
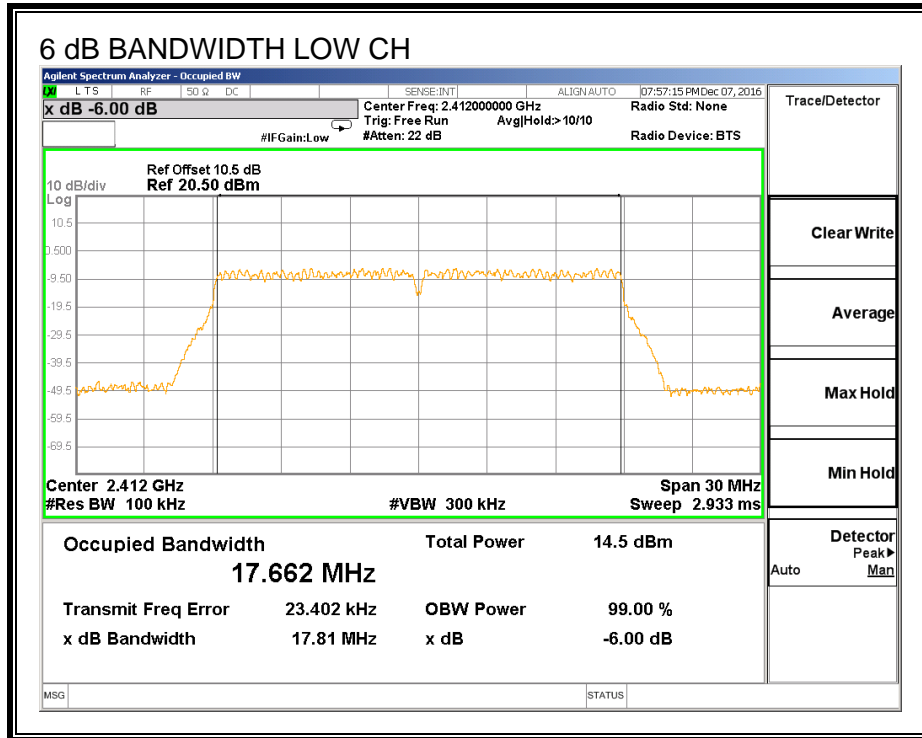

8.3. OUTPUT POWER

LIMITS

FCC §15.247

IC RSS-247, section 5.4

For systems using digital modulation in the 902–928 MHz, 2400–2483.5 MHz, and 5725–5850 MHz bands: 1 Watt, based on the use of antennas with directional gains that do not exceed 6 dBi. If transmitting antennas of directional gain greater than 6 dBi are used, the conducted output power from the intentional radiator shall be reduced by the amount in dB that the directional gain of the antenna exceeds 6 dBi.

RESULTS**Limits**

Channel	Frequency (MHz)	Directional Gain (dBi)	FCC Power Limit (dBm)	IC Power Limit (dBm)	IC EIRP Limit (dBm)	Max Power (dBm)
Low	2412	0.00	30.00	30	36	30.00
Mid	2437	0.00	30.00	30	36	30.00
High	2462	0.00	30.00	30	36	30.00

Duty Cycle CF (dB)	0.00	Included in Calculations of Corr'd Power
---------------------------	------	---

Results for 802.11b

Channel	Frequency (MHz)	Meas Power (dBm)	Total Corr'd Power (dBm)	Power Limit (dBm)	Margin (dB)
Low	2412	16.68	16.68	30.00	-13.32
Mid	2437	17.27	17.27	30.00	-12.73
High	2462	17.34	17.34	30.00	-12.66

Results for 802.11g

Channel	Frequency (MHz)	Meas Power (dBm)	Total Corr'd Power (dBm)	Power Limit (dBm)	Margin (dB)
Low	2412	14.20	14.20	0.00	14.20
Mid	2437	14.28	14.28	0.00	14.28
High	2462	14.20	14.20	0.00	14.20

Results for 802.11n

Channel	Frequency (MHz)	Meas Power (dBm)	Total Corr'd Power (dBm)	Power Limit (dBm)	Margin (dB)
Low	2412	13.33	13.33	0.00	13.33
Mid	2437	13.27	13.27	0.00	13.27
High	2462	13.02	13.02	0.00	13.02

OUTPUT POWER, 802.11b

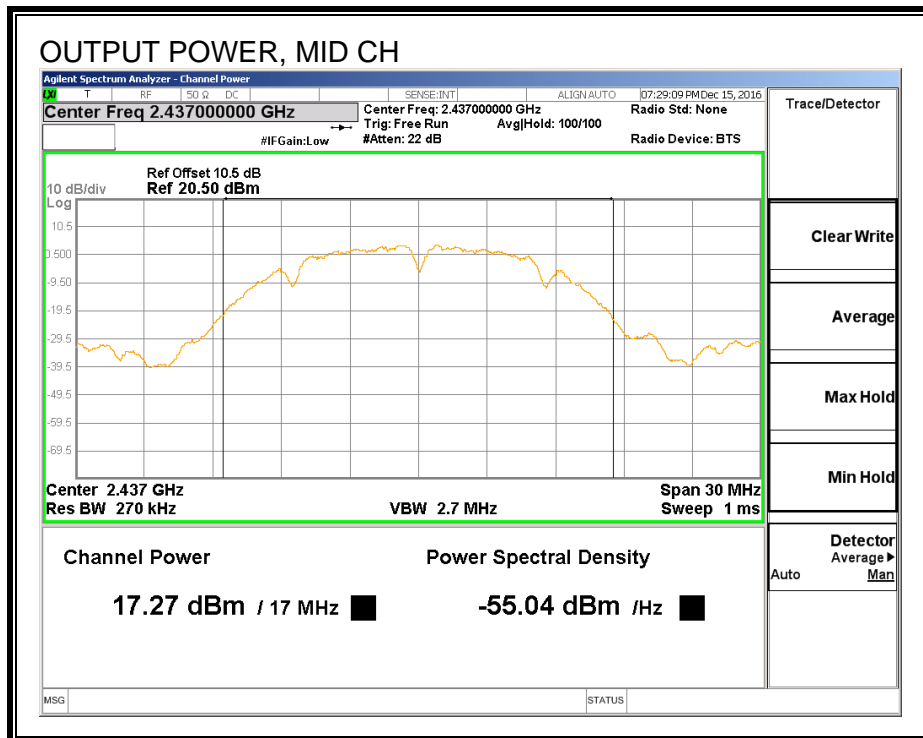
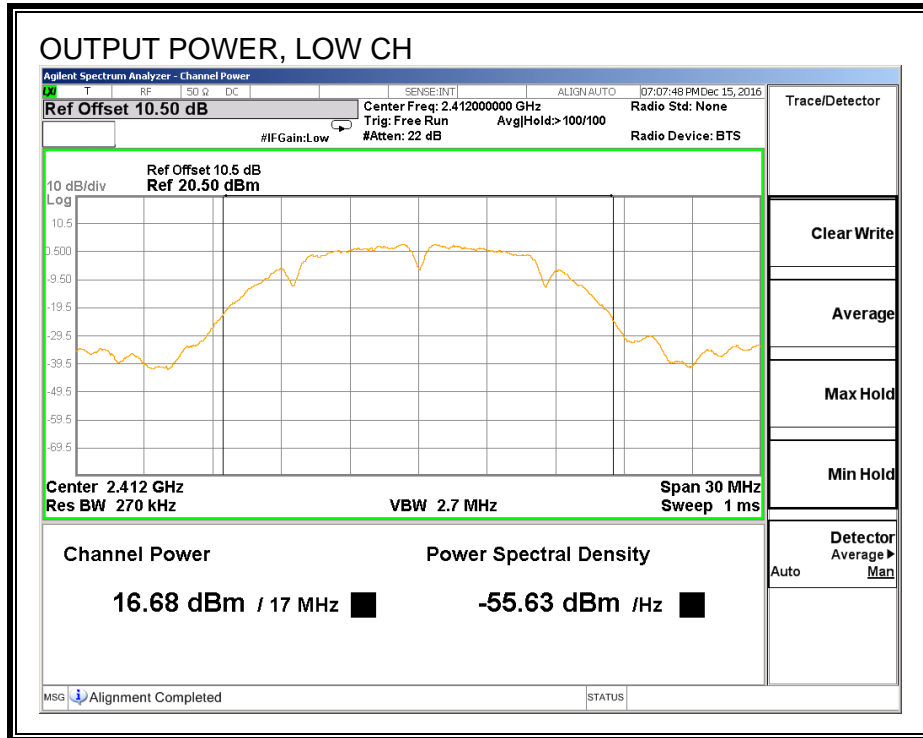

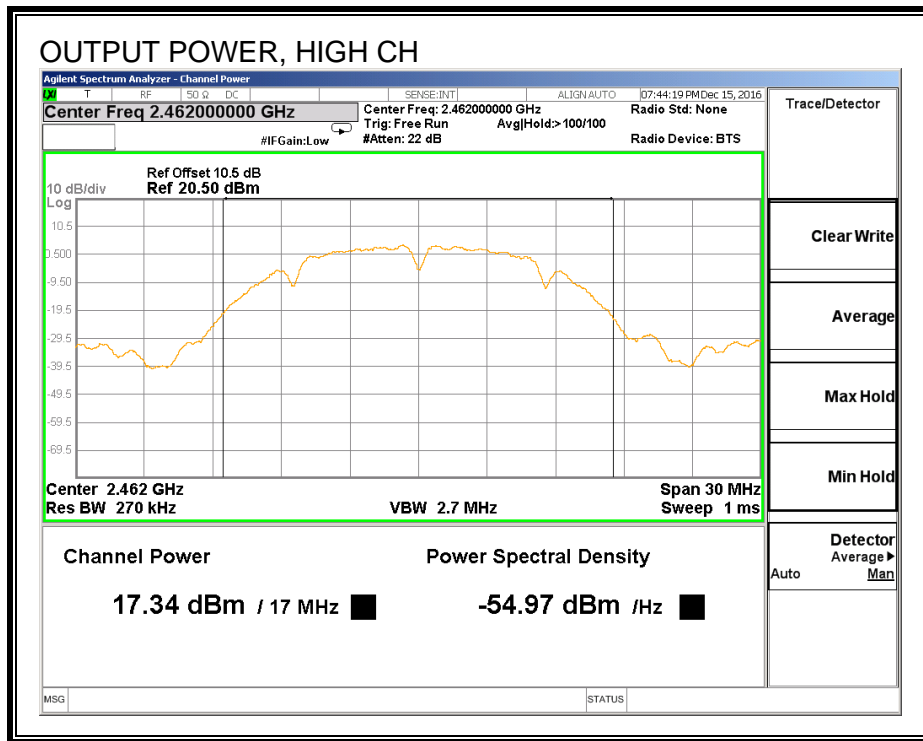

OUTPUT POWER, 802.11g

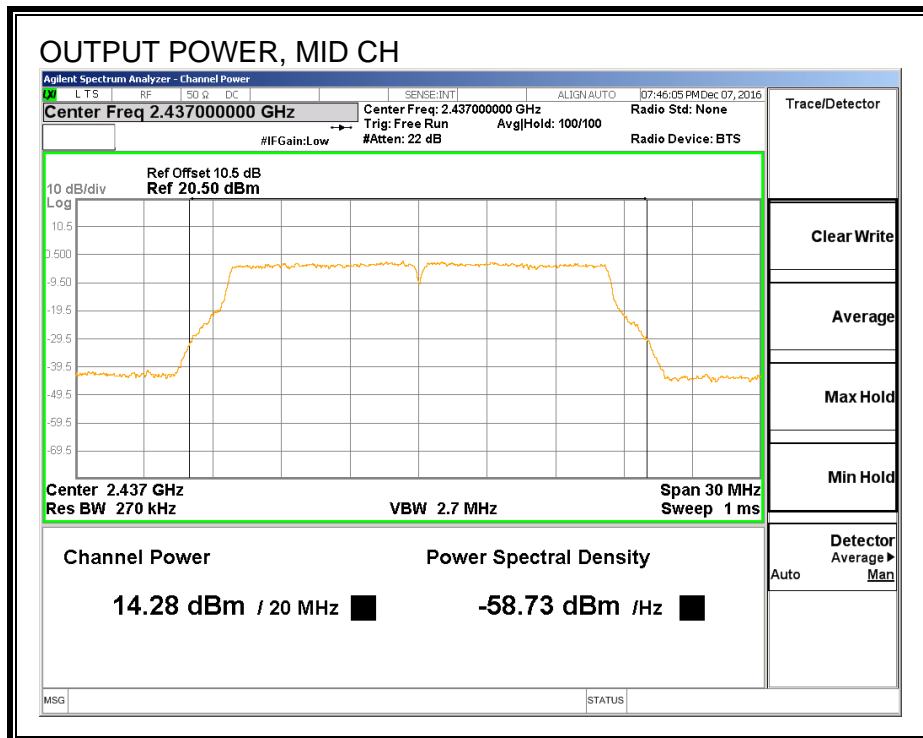
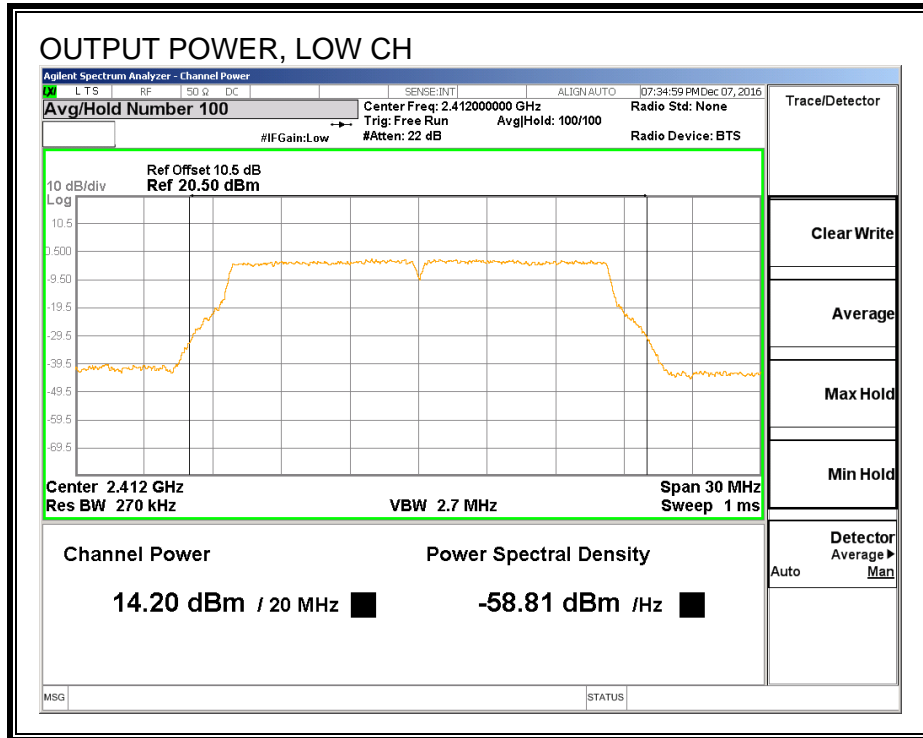

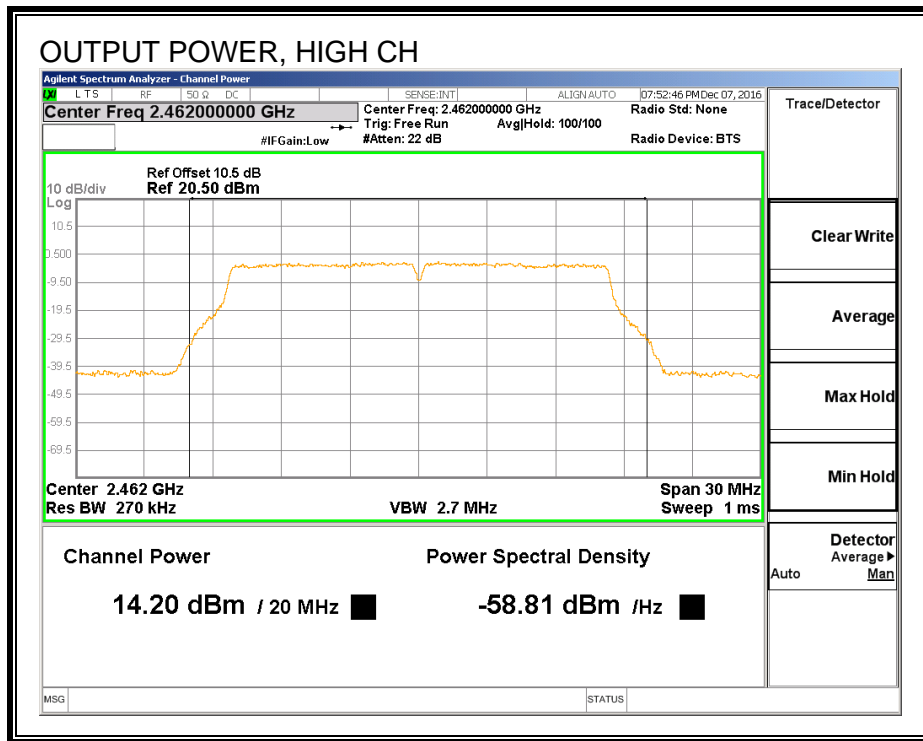

OUTPUT POWER, 802.11n20

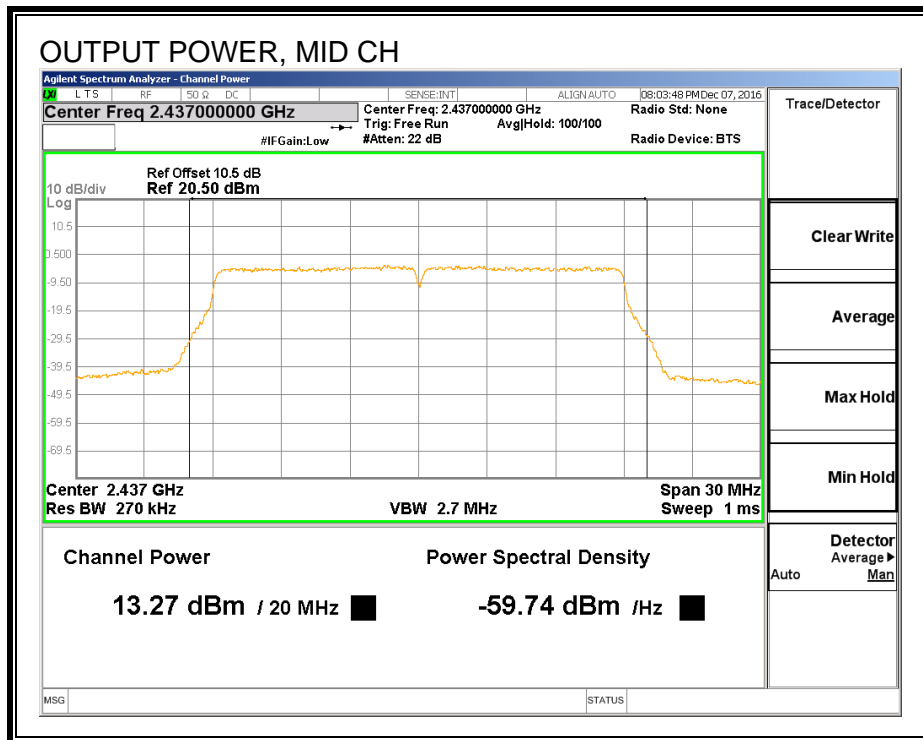
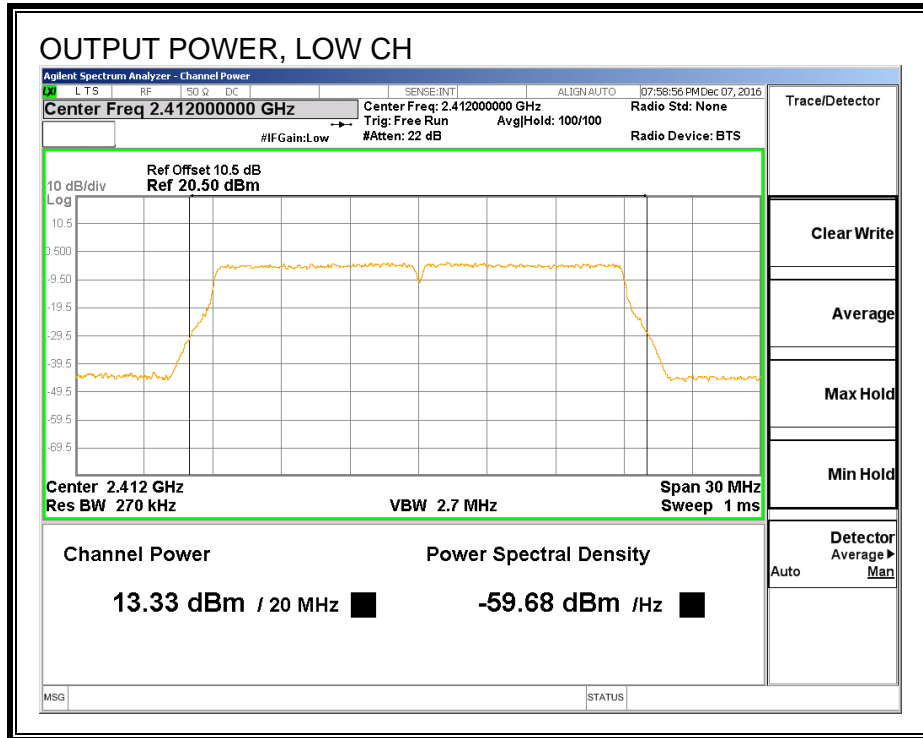

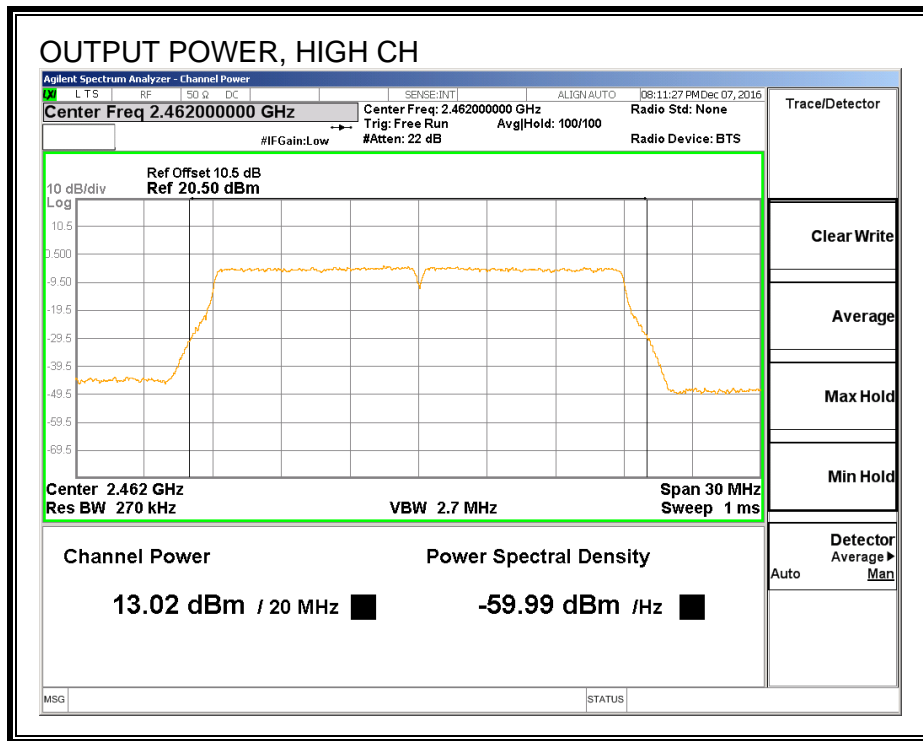

8.4. POWER SPECTRAL DENSITY

LIMITS

FCC §15.247

IC RSS-247, Section 5.2

RESULTS

Duty Cycle CF (dB)	0.00	Included in Calculations of Corr'd PSD
--------------------	------	--

PSD Results for 802.11b

Channel	Frequency (MHz)	Meas (dBm)	Total Corr'd PSD (dBm)	Limit (dBm)	Margin (dB)
Low	2412	-0.57	-0.57	8.0	-8.6
Mid	2437	0.03	0.03	8.0	-8.0
High	2462	-0.08	-0.08	8.0	-8.1

PSD Results for 802.11g

Channel	Frequency (MHz)	Meas (dBm)	Total Corr'd PSD (dBm)	Limit (dBm)	Margin (dB)
Low	2412	-11.04	-11.04	8.0	-19.0
Mid	2437	-10.51	-10.51	8.0	-18.5
High	2462	-10.27	-10.27	8.0	-18.3

PSD Results for 802.11n

Channel	Frequency (MHz)	Chain 0 Meas (dBm)	Total Corr'd PSD (dBm)	Limit (dBm)	Margin (dB)
Low	2412	-11.93	-11.93	8.0	-19.9
Mid	2437	-11.53	-11.53	8.0	-19.5
High	2462	-11.52	-11.52	8.0	-19.5

PSD, 802.11b

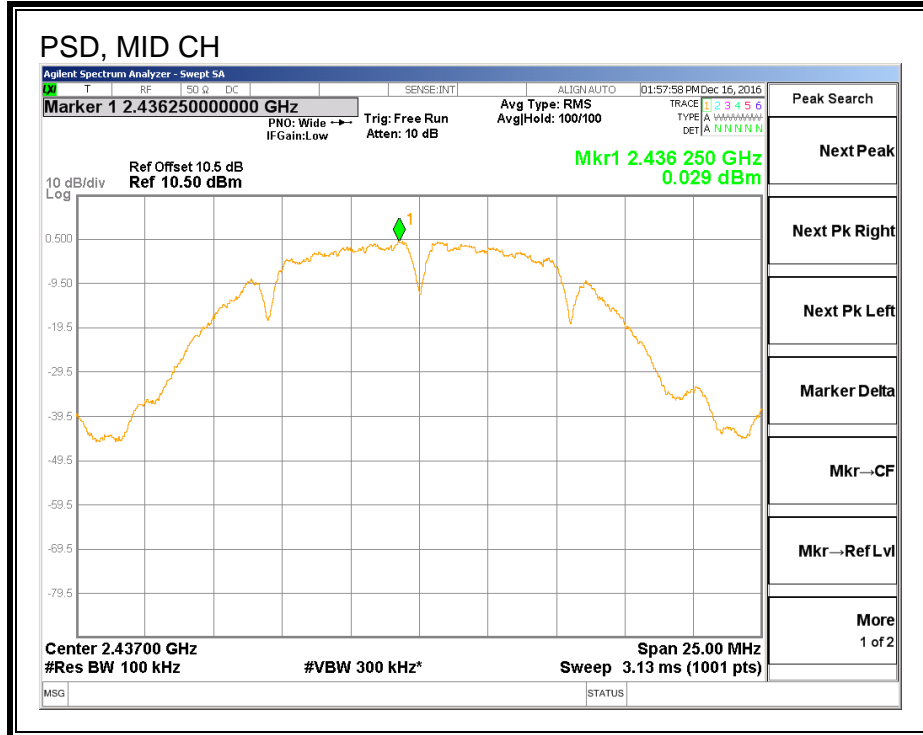
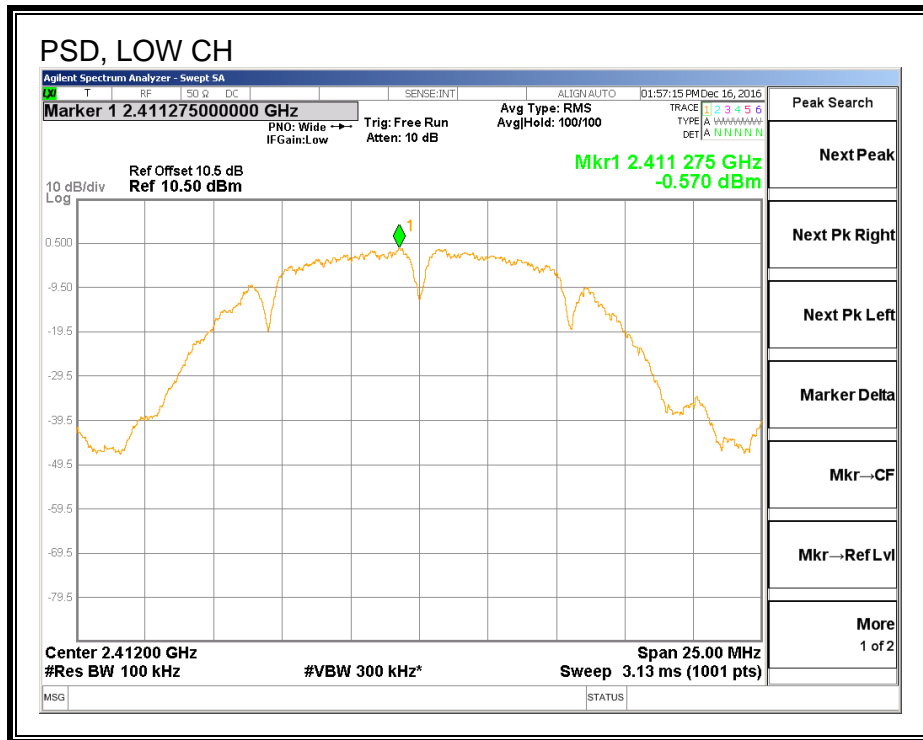

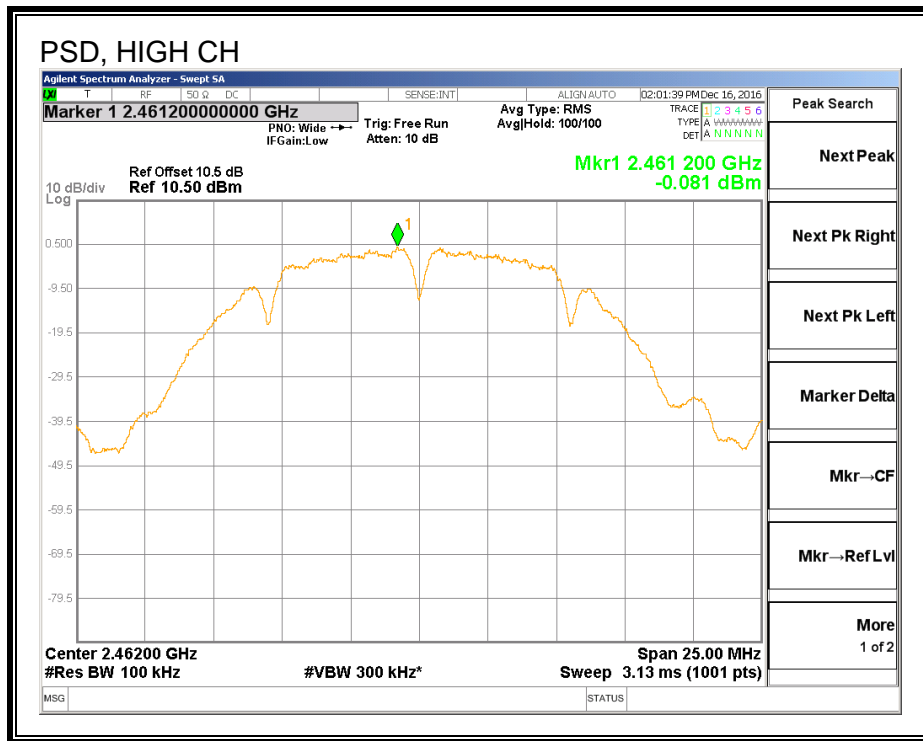

PSD, 802.11g

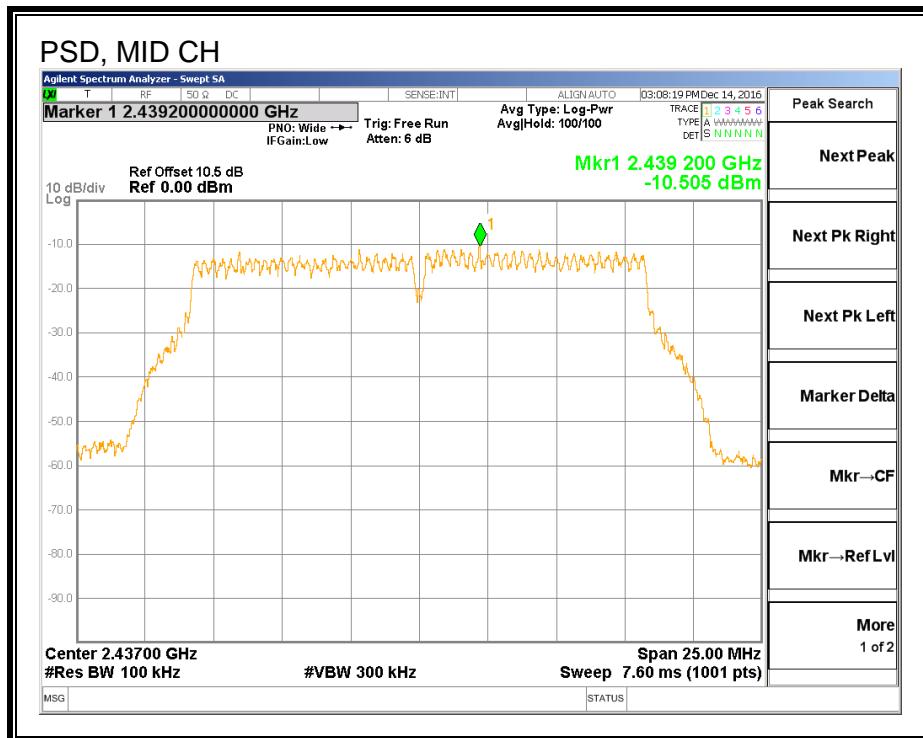
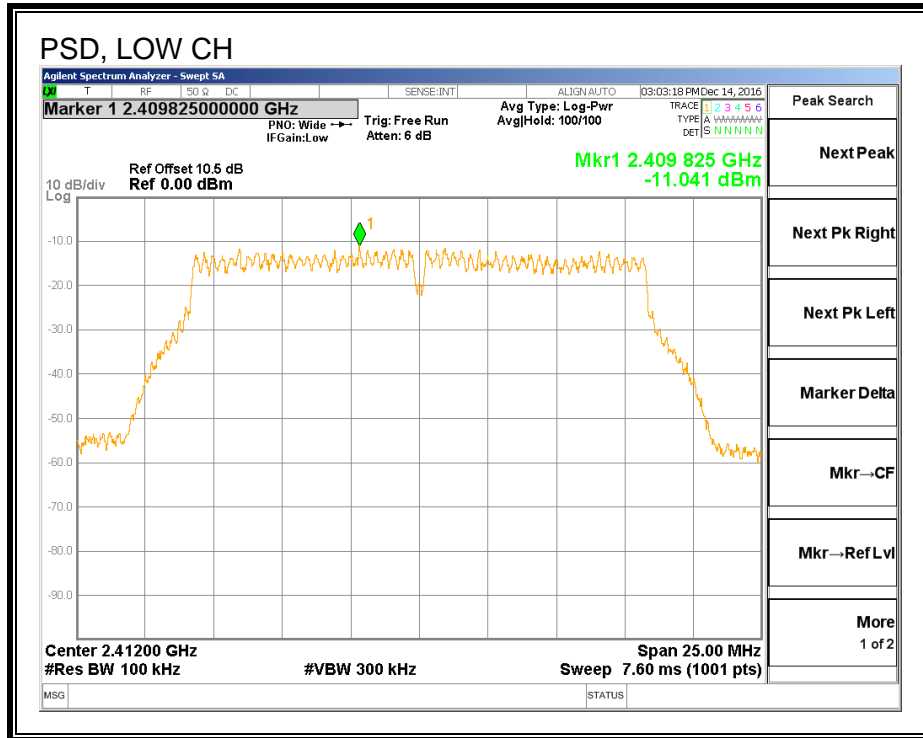

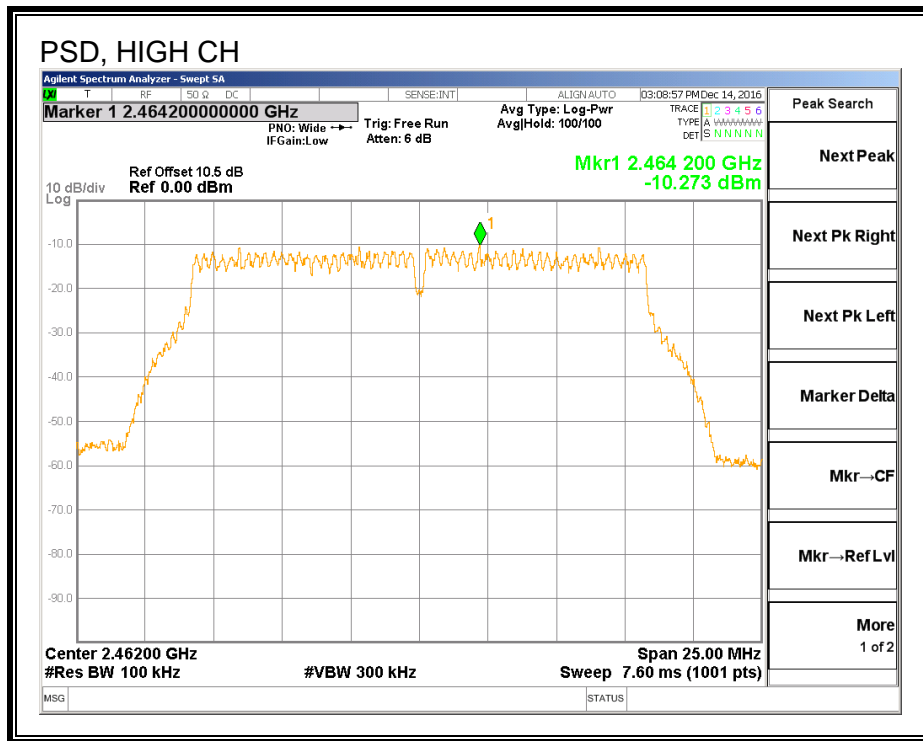

PSD, 802.11n

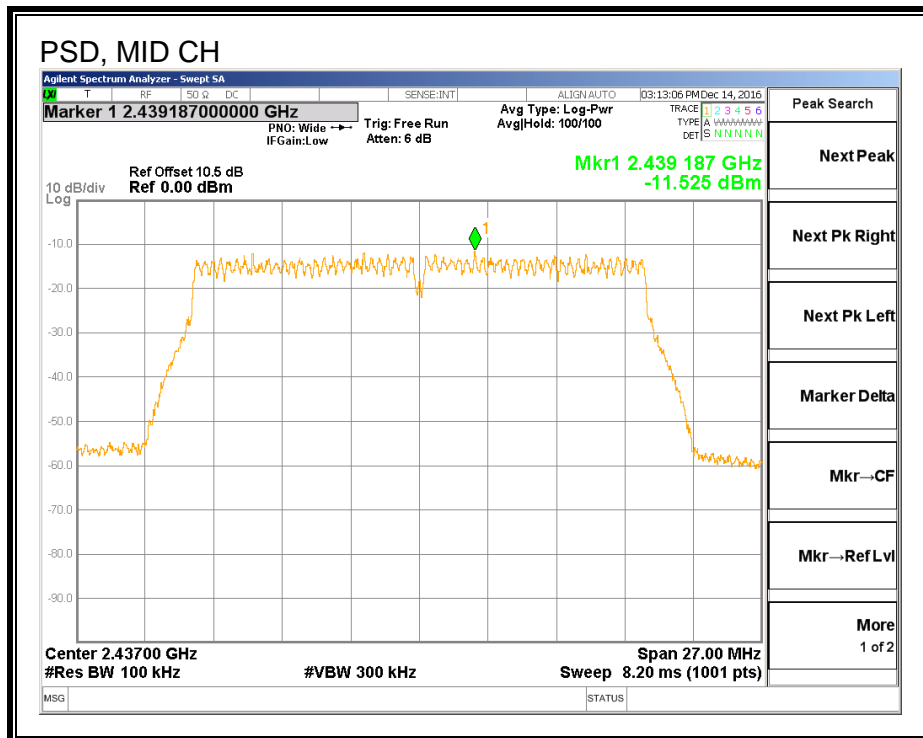
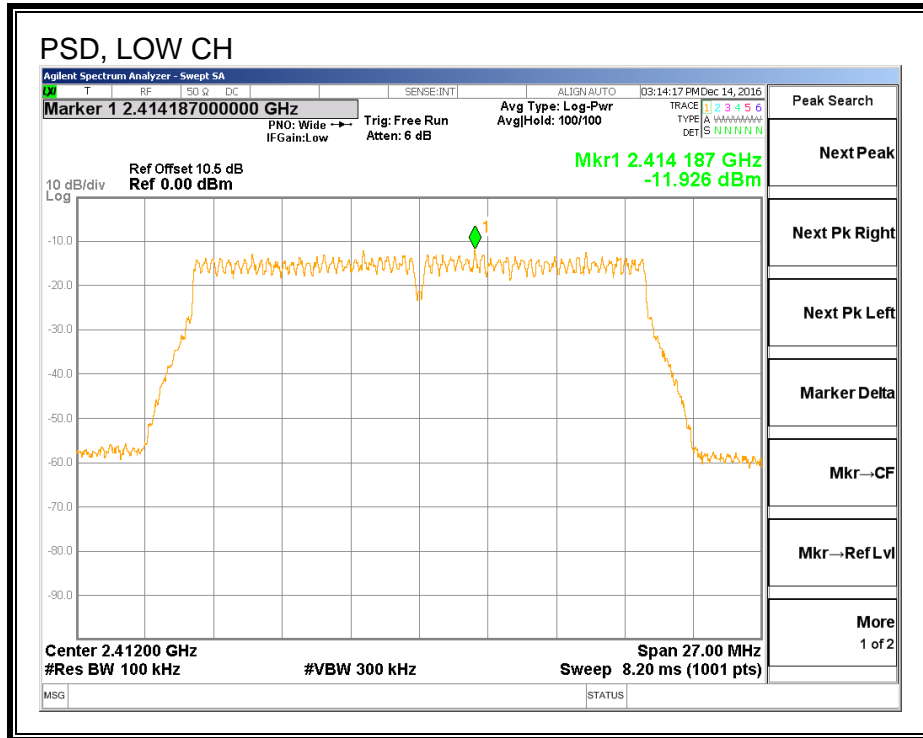

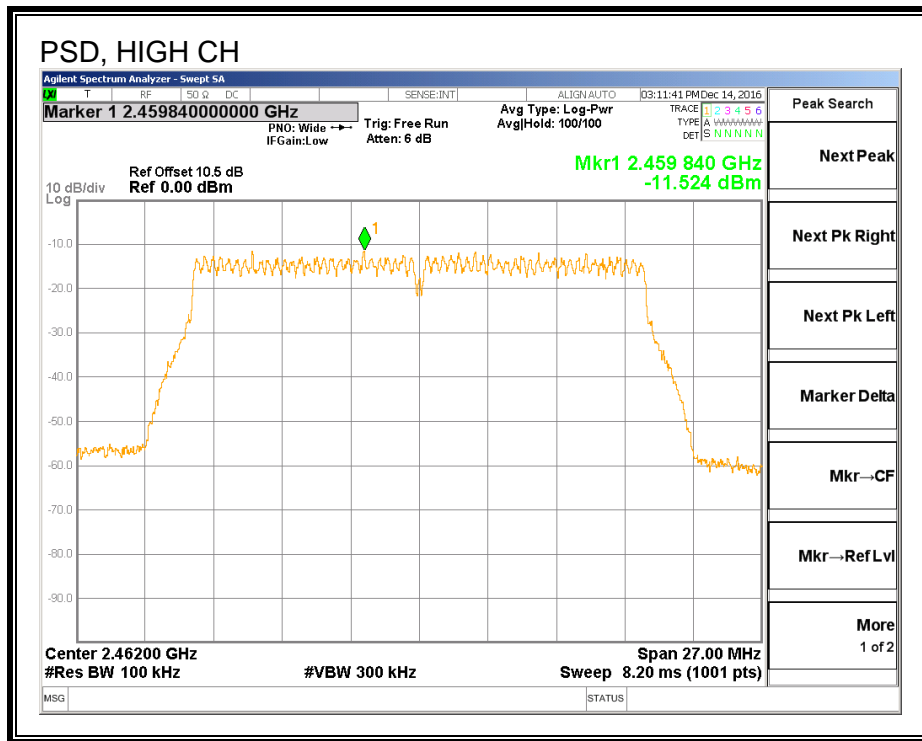

8.5. CONDUCTED OUT-OF-BAND EMISSIONS

LIMITS

FCC §15.247 (d)

IC RSS-247, section 5.5

In any 100 kHz bandwidth outside the frequency band in which the spread spectrum or digitally modulated intentional radiator is operating, the radio frequency power that is produced by the intentional radiator shall be at least 20 dB below that in the 100 kHz bandwidth within the band that contains the highest level of the desired power, based on either an RF conducted or a radiated measurement, provided the transmitter demonstrates compliance with the peak conducted power limits. If the transmitter complies with the conducted power limits based on the use of RMS averaging over a time interval, as permitted under paragraph (b)(3) of this section, the attenuation required under this paragraph shall be 30 dB instead of 20 dB. Attenuation below the general limits specified in §15.209(a) is not required.

RESULTS for 802.11b

LOW CHANNEL BANDEDGE

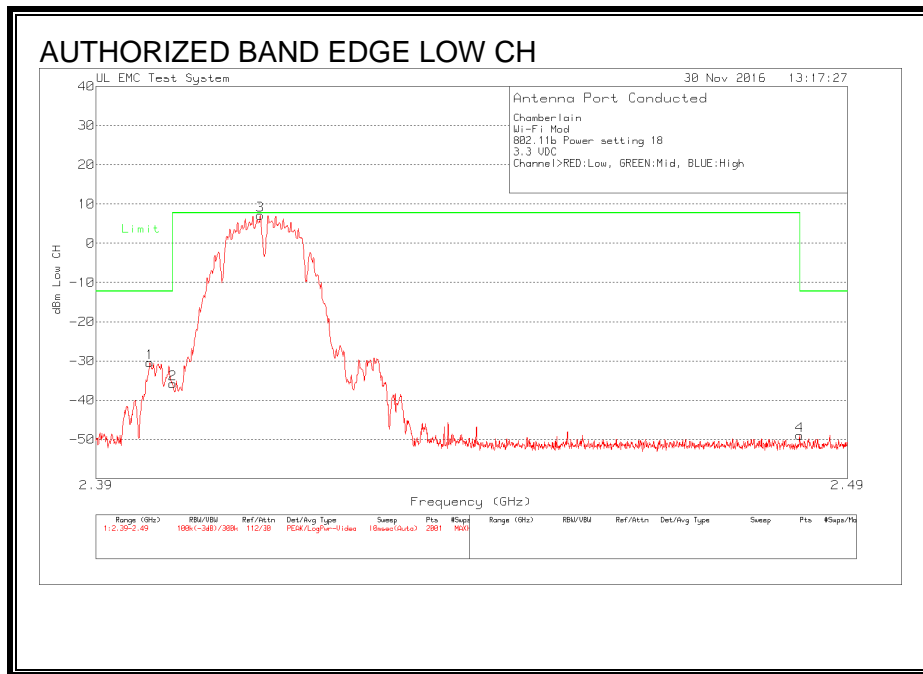

Chamberlain
 Wi-Fi Mod
 802.11b Power setting 18
 3.3 VDC
 Channel>RED:Low, GREEN:Mid, BLUE:High

Trace Markers

Test No.	Frequency (GHz)	Meter Reading	Transducer Factor (dB)	Gain/Loss Factor (dB)	Corrected Reading dBm	Limit:1
1	2.397	66.05dBuV Pk	-107	10.5	-30.45	-12.26
					Margin (dB)	-18.19
2	2.4	60.69dBuV Pk	-107	10.5	-35.81	-12.26
					Margin (dB)	-23.55
3	2.4115	103.74dBuV Pk	-107	10.4	7.14	7.74
					Margin (dB)	-.6
4	2.4835	47.51dBuV Pk	-107	10.5	-48.99	-12.26
					Margin (dB)	-36.73

LIMIT 1: Limit
 Pk - Peak detector

HIGH CHANNEL BANDEDGE for 802.11b

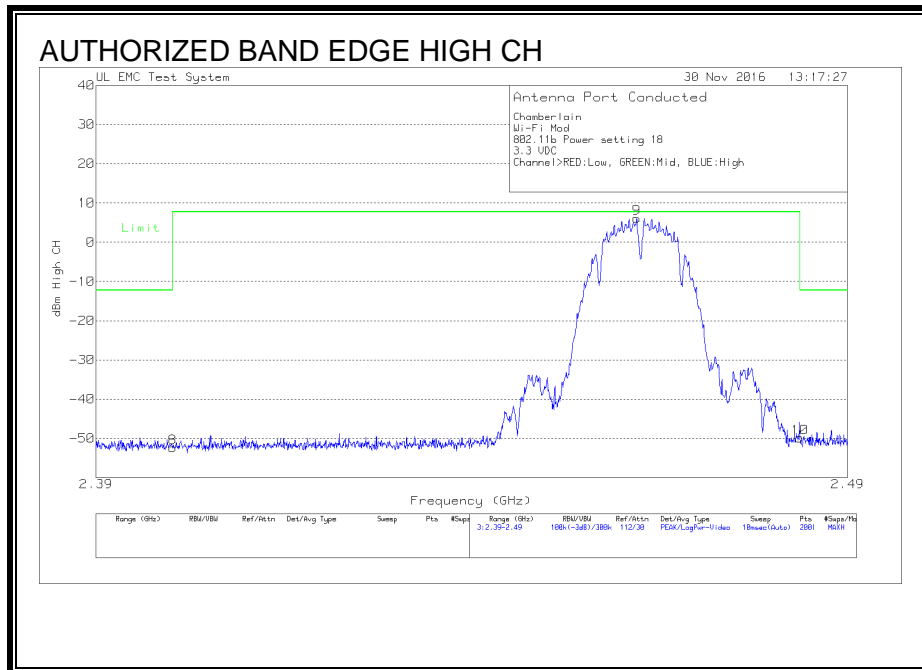

Chamberlain
 Wi-Fi Mod
 802.11b Power setting 18
 3.3 VDC
 Channel>RED:Low, GREEN:Mid, BLUE:High

Trace Markers

Test No.	Frequency (GHz)	Meter Reading	Transducer Factor (dB)	Gain/Loss Factor (dB)	Corrected Reading dBm	Limit:1
8	2.4	44.09dBuV Pk	-107	10.5	-52.41	-12.26
					Margin (dB)	-40.15
9	2.4615	102.61dBuV Pk	-107	10.5	6.11	7.74
					Margin (dB)	-1.63
10	2.4835	46.61dBuV Pk	-107	10.5	-49.89	-12.26
					Margin (dB)	-37.63

LIMIT 1: Limit
 Pk - Peak detector

OUT-OF-BAND EMISSIONS Plots for 802.11b

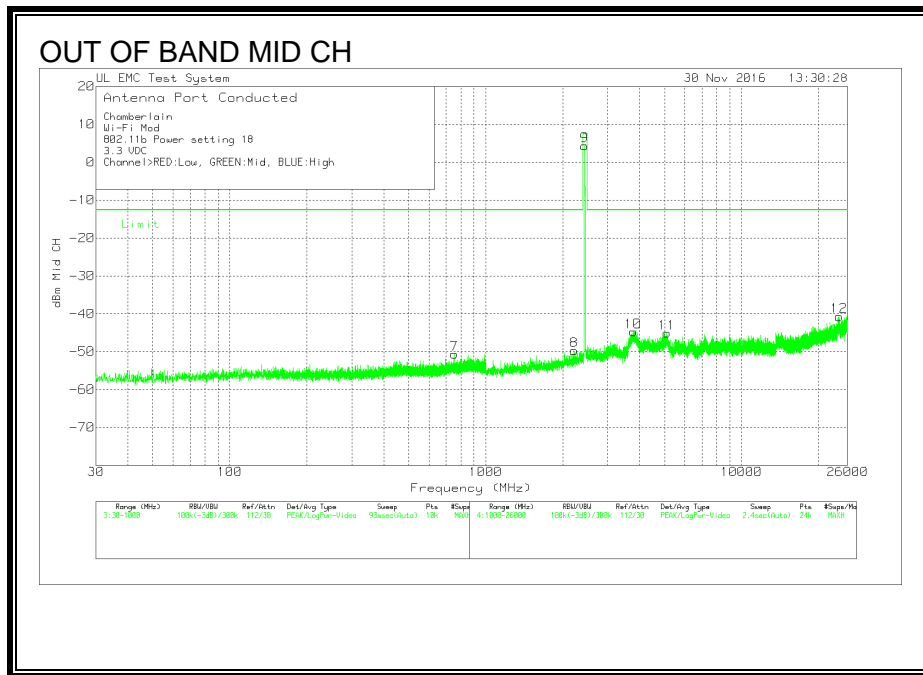
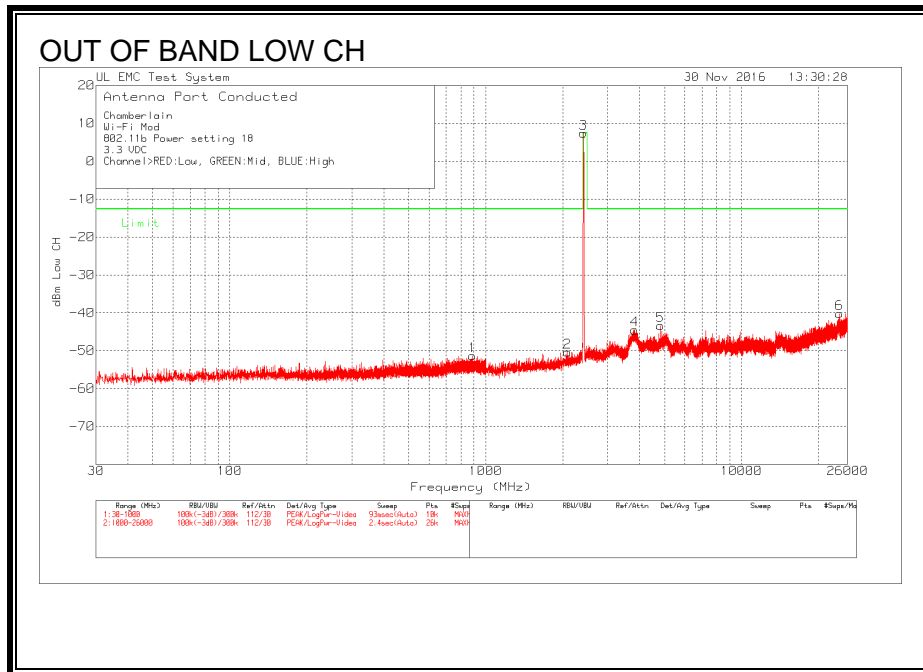

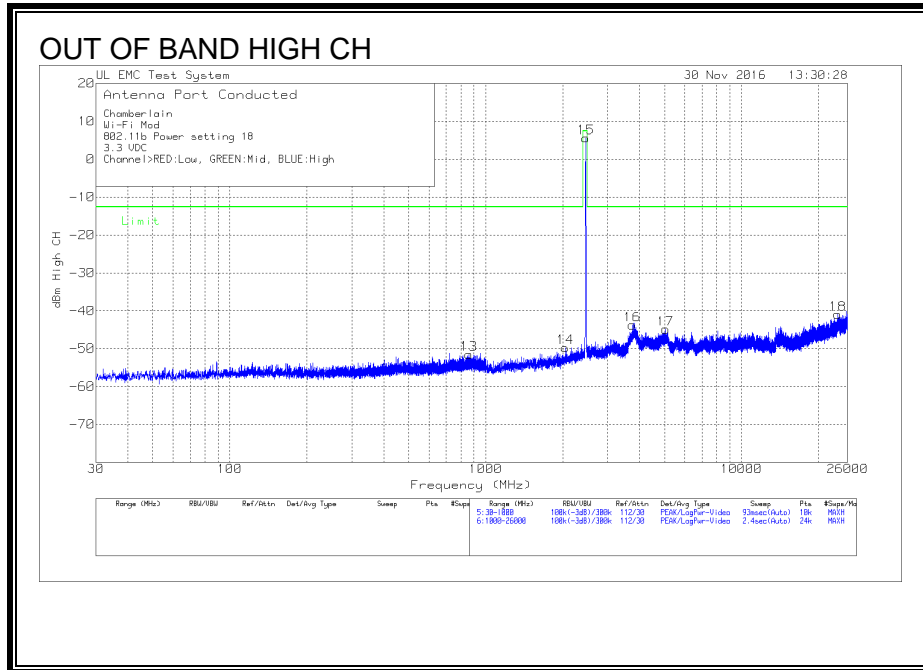

OUT-OF-BAND EMISSIONS Data for 802.11b

Chamberlain
 Wi-Fi Mod
 802.11b Power setting 18
 3.3 VDC
 Channel>RED:Low, GREEN:Mid, BLUE:High

Trace Markers						
No.	Test Frequency (MHz)	Meter Reading	Transducer Factor (dB)	Gain/Loss Factor (dB)	Corrected Reading dBm	Limit:1
=====						
Low Channel						
1	887.674	45.38dBuV Pk	-107	10.3	-51.32	-12.6
					Margin (dB)	-38.72
2	2084.573	46.26dBuV Pk	-107	10.4	-50.34	-12.6
					Margin (dB)	-37.74
3	2411.483	104dBuV Pk	-107	10.4	7.4	7.4
					Margin (dB)	0
4	3819.121	51.66dBuV Pk	-107	10.8	-44.54	-12.6
					Margin (dB)	-31.94
5	4823.889	52.81dBuV Pk	-107	10.8	-43.39	-12.6
					Margin (dB)	-30.79
6	24113.523	55.21dBuV Pk	-107	11.6	-40.19	-12.6
					Margin (dB)	-27.59
Middle Channel						
7	755.56	46.14dBuV Pk	-107	10.2	-50.66	-12.6
					Margin (dB)	-38.06
8	2215.574	46.9dBuV Pk	-107	10.4	-49.7	-12.6
					Margin (dB)	-37.1
9	2436.919	100.82dBuV Pk	-107	10.5	4.32	7.4
					Margin (dB)	-3.08
10	3772.8	51.47dBuV Pk	-107	10.8	-44.73	-12.6
					Margin (dB)	-32.13
11	5106.078	51.11dBuV Pk	-107	10.8	-45.09	-12.6
					Margin (dB)	-32.49
12	24078.199	54.57dBuV Pk	-107	11.7	-40.73	-12.6
					Margin (dB)	-28.13
High Channel						
13	859.3015	45.27dBuV Pk	-107	10.2	-51.53	-12.6
					Margin (dB)	-38.93
14	2045.789	46.84dBuV Pk	-107	10.4	-49.76	-12.6
					Margin (dB)	-37.16
15	2463.48	102.1dBuV Pk	-107	10.5	5.6	7.4
					Margin (dB)	-1.8
16	3736.344	52.44dBuV Pk	-107	10.8	-43.76	-12.6
					Margin (dB)	-31.16
17	5047.747	51.23dBuV Pk	-107	10.9	-44.87	-12.6
					Margin (dB)	-32.27
18	23784.462	54.25dBuV Pk	-107	11.8	-40.95	-12.6
					Margin (dB)	-28.35

LIMIT 1: Limit
 Pk - Peak detector

RESULTS for 802.11g

LOW CHANNEL BANDEDGE

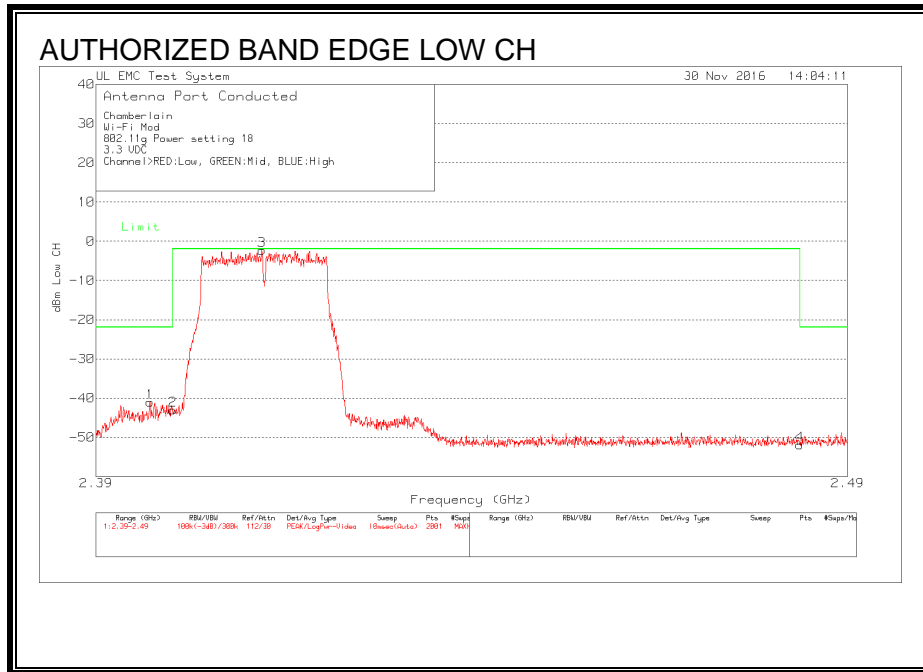

Chamberlain
 Wi-Fi Mod
 802.11g Power setting 18
 3.3 VDC
 Channel>RED:Low, GREEN:Mid, BLUE:High

Trace Markers

Test No.	Frequency (GHz)	Meter Reading	Transducer Factor (dB)	Gain/Loss Factor (dB)	Corrected Reading dBm	Limit:1
=====						
Low Channel						
1	2.39705	55.46dBuV Pk	-107	10.5	-41.04	-21.92
					Margin (dB)	-19.12
2	2.4	53.46dBuV Pk	-107	10.5	-43.04	-21.92
					Margin (dB)	-21.12
3	2.4117	94.28dBuV Pk	-107	10.4	-2.32	-1.92
					Margin (dB)	-.4
4	2.4835	44.58dBuV Pk	-107	10.5	-51.92	-21.92
					Margin (dB)	-30

LIMIT 1: Limit
 Pk - Peak detector

HIGH CHANNEL BANDEGE for 802.11g

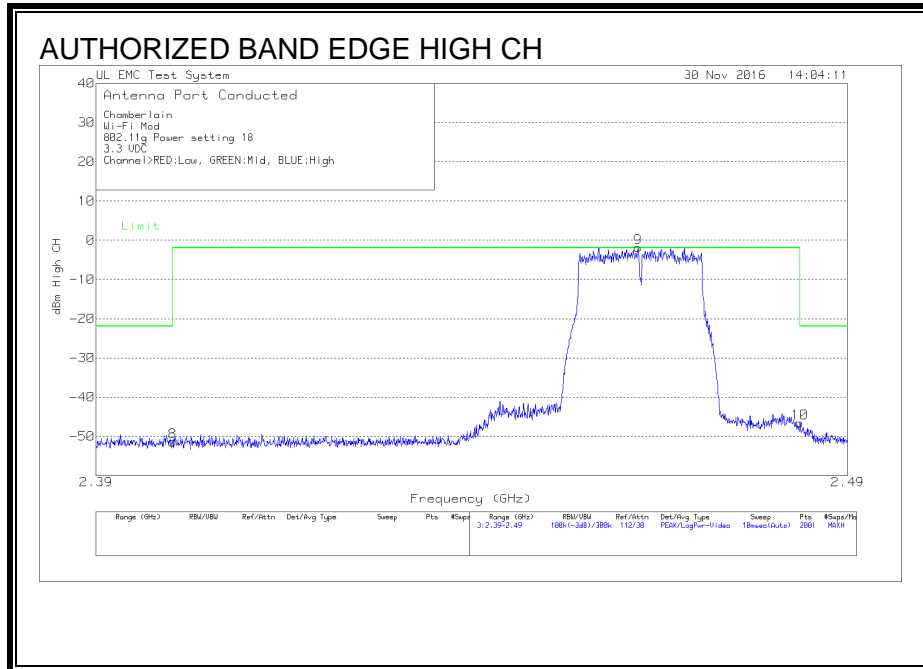

Chamberlain
 Wi-Fi Mod
 802.11g Power setting 18
 3.3 VDC
 Channel>RED:Low, GREEN:Mid, BLUE:High

Trace Markers

Test No.	Frequency (GHz)	Meter Reading	Transducer Factor (dB)	Gain/Loss Factor (dB)	Corrected Reading dBm	Limit:1
8	2.4	45.1dBuV Pk	-107	10.5	-51.4	-21.92
					Margin (dB)	-29.48
9	2.4617	94.58dBuV Pk	-107	10.5	-1.92	-1.92
					Margin (dB)	0
10	2.4835	49.98dBuV Pk	-107	10.5	-46.52	-21.92
					Margin (dB)	-24.6

LIMIT 1: Limit
 Pk - Peak detector

OUT-OF-BAND EMISSIONS Plots for 802.11g

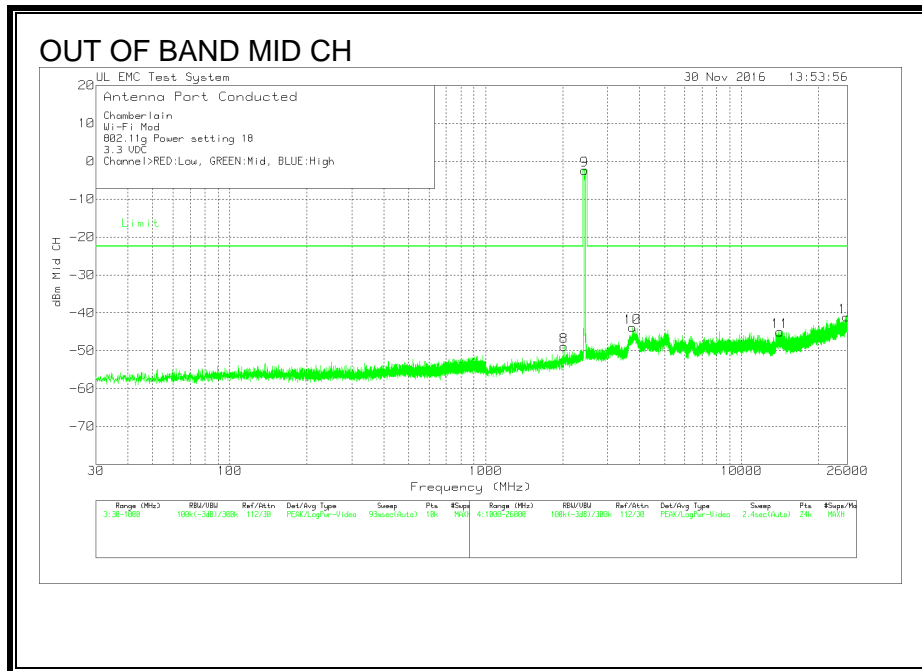
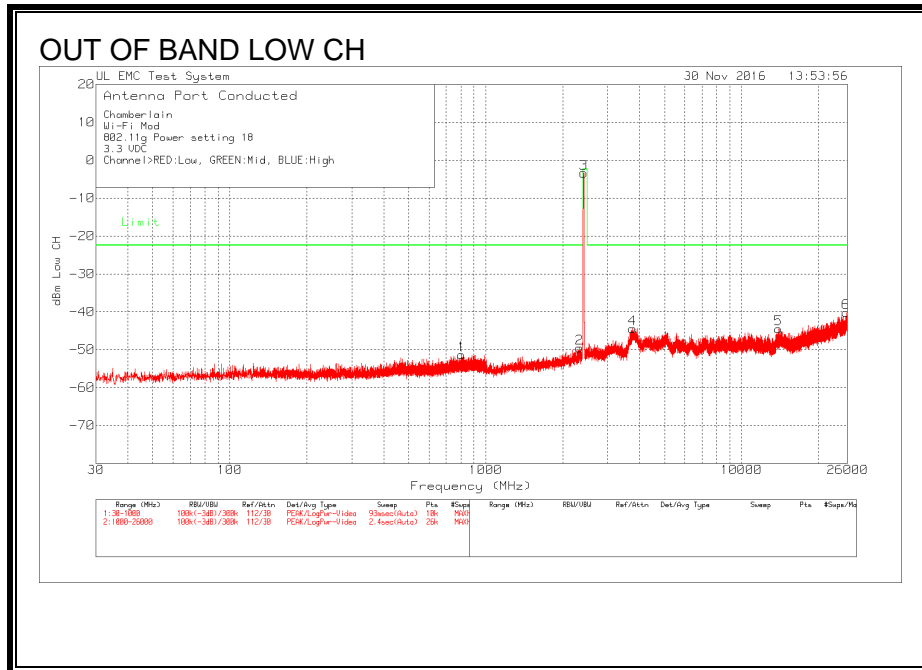

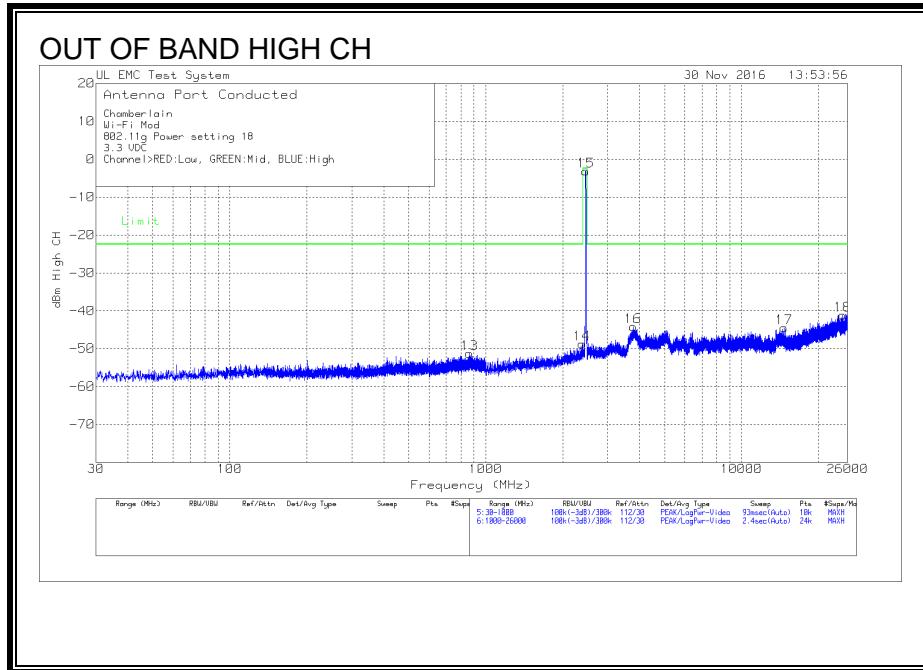

OUT-OF-BAND EMISSIONS Data for 802.11g

Chamberlain
 Wi-Fi Mod
 802.11g Power setting 18
 3.3 VDC
 Channel RED:Low, GREEN:Mid, BLUE:High

Trace Markers						
No.	Test Frequency (MHz)	Meter Reading	Transducer Factor (dB)	Gain/Loss Factor (dB)	Corrected Reading dBm	Limit:1
=====						
Low Channel						
1	805.03	45.45dBuV Pk	-107	10.2	-51.35	-22.42
					Margin (dB)	-28.93
2	2323.987	47.06dBuV Pk	-107	10.4	-49.54	-22.42
					Margin (dB)	-27.12
3	2416.291	93.11dBuV Pk	-107	10.5	-3.39	-2.42
					Margin (dB)	-.97
4	3744.124	51.79dBuV Pk	-107	10.8	-44.41	-22.42
					Margin (dB)	-21.99
5	13947.572	51.19dBuV Pk	-107	11.3	-44.51	-22.42
					Margin (dB)	-22.09
6	25600.965	55.09dBuV Pk	-107	11.7	-40.21	-22.42
					Margin (dB)	-17.79
Middle Channel						
7	923.467	-51.44dBuV Pk	-107	10.2	-148.24	-22.42
					Margin (dB)	-125.82
8	2020.791	47.72dBuV Pk	-107	10.4	-48.88	-22.42
					Margin (dB)	-26.46
9	2436.398	94.08dBuV Pk	-107	10.5	-2.42	-2.42
					Margin (dB)	0
10	3748.843	52.32dBuV Pk	-107	10.8	-43.88	-22.42
					Margin (dB)	-21.46
11	14134.866	50.68dBuV Pk	-107	11.3	-45.02	-22.42
					Margin (dB)	-22.6
12	25788.544	54.12dBuV Pk	-107	11.8	-41.08	-22.42
					Margin (dB)	-18.66
High Channel						
13	865.17	45.42dBuV Pk	-107	10.3	-51.28	-22.42
					Margin (dB)	-28.86
14	2378.067	47.79dBuV Pk	-107	10.5	-48.71	-22.42
					Margin (dB)	-26.29
15	2463.48	93.33dBuV Pk	-107	10.5	-3.17	-2.42
					Margin (dB)	-.75
16	3771.759	52dBuV Pk	-107	10.8	-44.2	-22.42
					Margin (dB)	-21.78
17	14668.177	51.2dBuV Pk	-107	11.3	-44.5	-22.42
					Margin (dB)	-22.08
18	24843.792	54.07dBuV Pk	-107	11.8	-41.13	-22.42
					Margin (dB)	-18.71

LIMIT 1: Limit
 Pk - Peak detector

RESULTS for 802.11n

LOW CHANNEL BANDEDGE

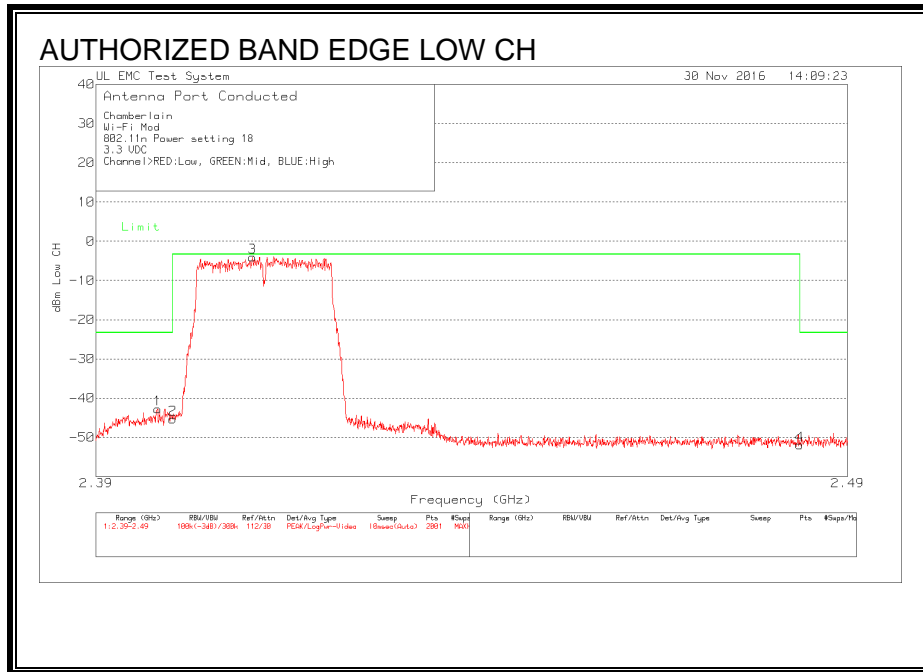

Chamberlain
 Wi-Fi Mod
 802.11n Power setting 18
 3.3 VDC
 Channel RED:Low, GREEN:Mid, BLUE:High

Trace Markers

Test No.	Frequency (GHz)	Meter Reading	Transducer Factor (dB)	Gain/Loss Factor (dB)	Corrected Reading dBm	Limit:1
=====						
Low Channel						
1	2.39805	53.75dBuV Pk	-107	10.5	-42.75	-23.3
					Margin (dB)	-19.45
2	2.4	51.18dBuV Pk	-107	10.5	-45.32	-23.3
					Margin (dB)	-22.02
3	2.410475	92.55dBuV Pk	-107	10.4	-4.05	-3.3
					Margin (dB)	-.75
4	2.4835	44.57dBuV Pk	-107	10.5	-51.93	-23.3
					Margin (dB)	-28.63

LIMIT 1: Limit
 Pk - Peak detector

HIGH CHANNEL BANDEGE for 802.11n

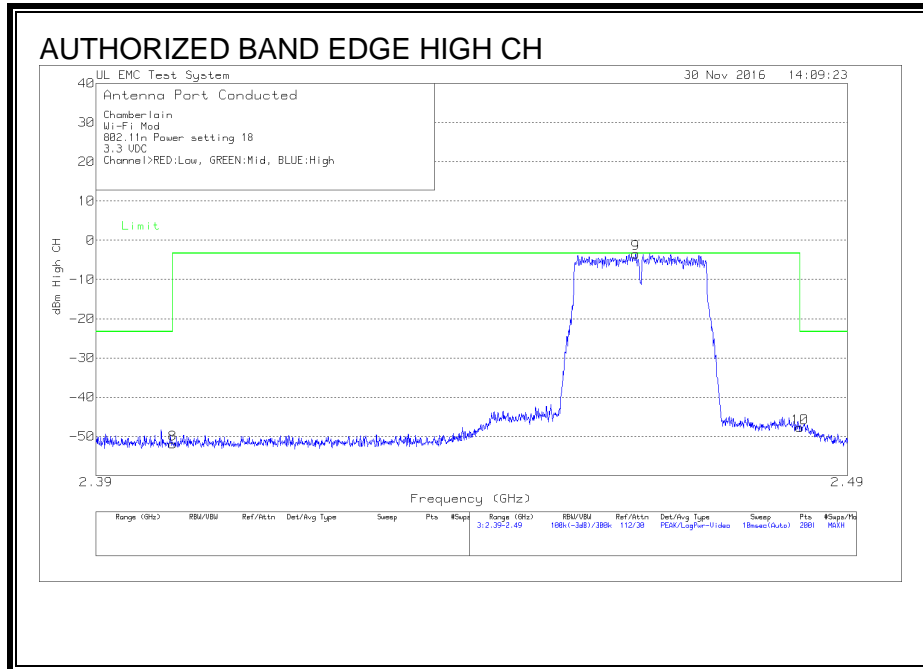

Chamberlain
 Wi-Fi Mod
 802.11n Power setting 18
 3.3 VDC
 Channel RED:Low, GREEN:Mid, BLUE:High

Trace Markers

Test No.	Frequency (GHz)	Meter Reading	Transducer Factor (dB)	Gain/Loss Factor (dB)	Corrected Reading dBm	Limit:1
=====						
High Channel						
8	2.4	44.53dBuV Pk	-107	10.5	-51.97	-23.3
					Margin (dB)	-28.67
9	2.4614	93.04dBuV Pk	-107	10.5	-3.46	-3.3
					Margin (dB)	-.16
10	2.4835	48.72dBuV Pk	-107	10.5	-47.78	-23.3
					Margin (dB)	-24.48

LIMIT 1: Limit
 Pk - Peak detector

OUT-OF-BAND EMISSIONS Plots for 802.11b

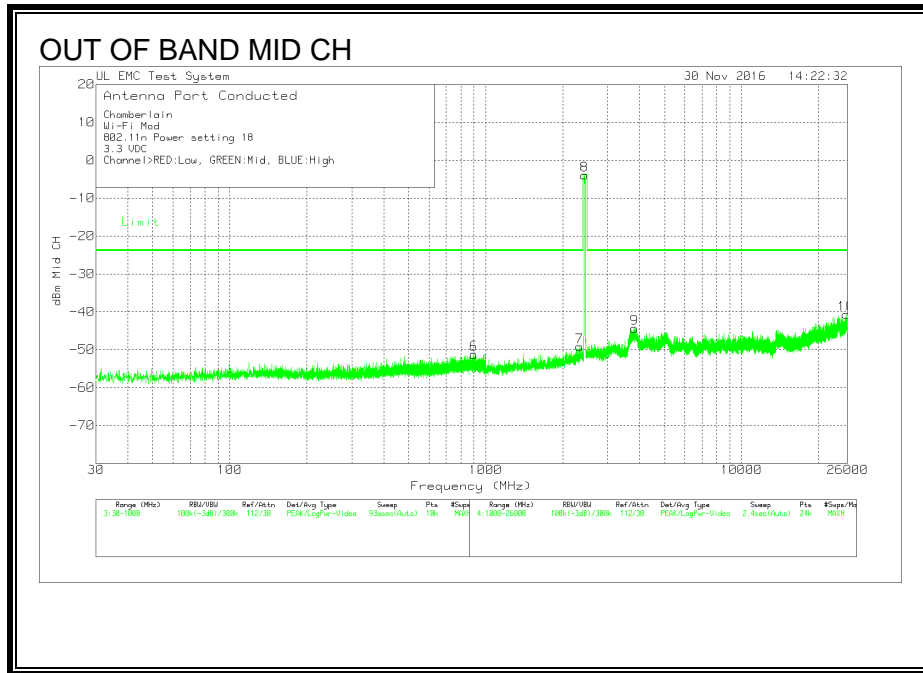
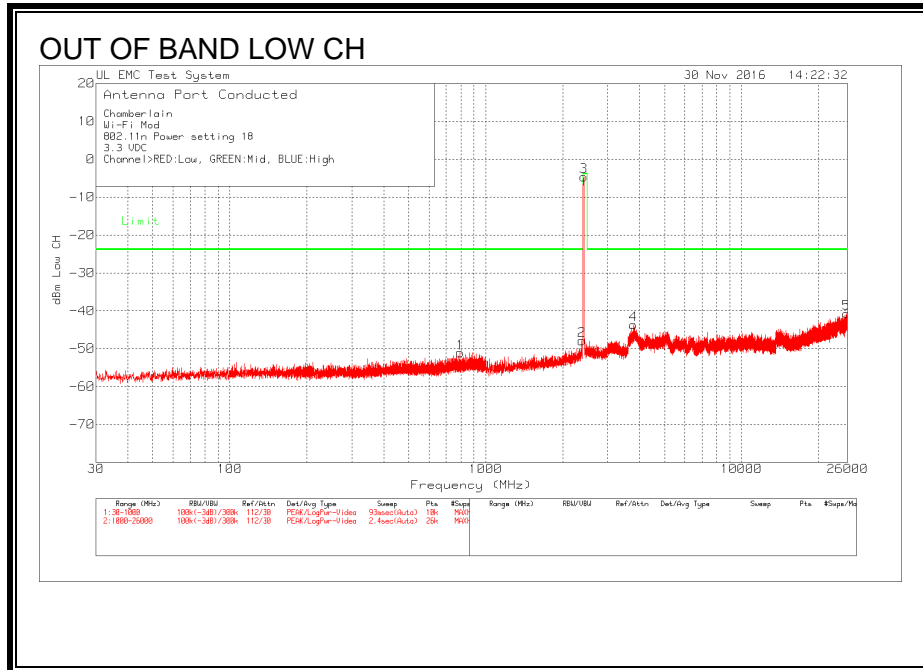

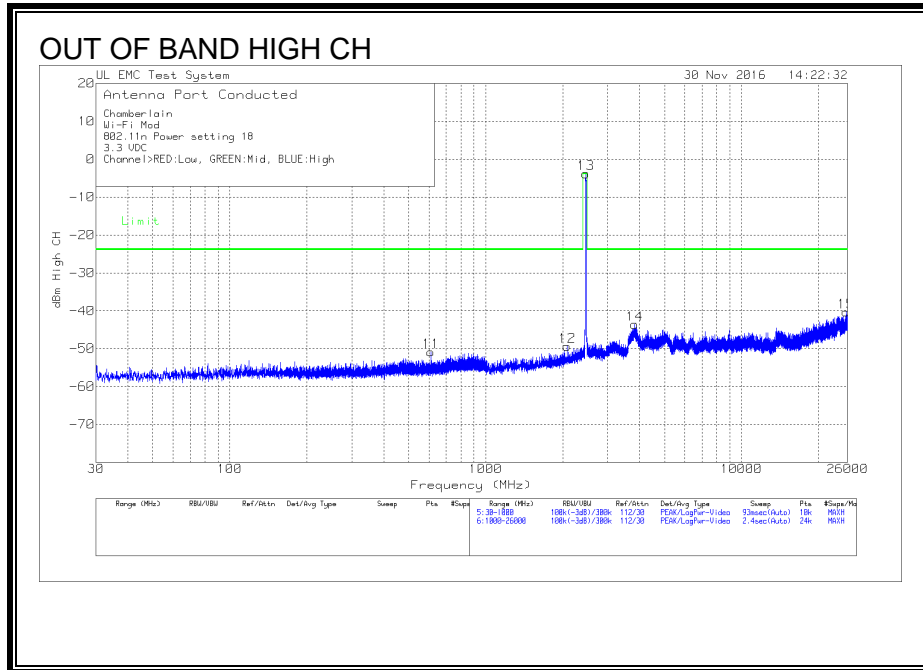

OUT-OF-BAND EMISSIONS Data for 802.11n

Chamberlain
 Wi-Fi Mod
 802.11n Power setting 18
 3.3 VDC
 Channel RED:Low, GREEN:Mid, BLUE:High

Trace Markers						
No.	Test Frequency (MHz)	Meter Reading	Transducer Factor (dB)	Gain/Loss Factor (dB)	Corrected Reading dBm	Limit:1
=====						
Low Channel						
1	794.748	45.72dBuV Pk	-107	10.2	-51.08	-23.83
					Margin (dB)	-27.25
2	2375.908	48.63dBuV Pk	-107	10.5	-47.87	-23.83
					Margin (dB)	-24.04
3	2420.137	91.87dBuV Pk	-107	10.5	-4.63	-3.83
					Margin (dB)	-.8
4	3781.622	52.48dBuV Pk	-107	10.8	-43.72	-23.83
					Margin (dB)	-19.89
5	25742.305	54.62dBuV Pk	-107	11.7	-40.68	-23.83
					Margin (dB)	-16.85
Middle Channel						
6	898.829	45.6dBuV Pk	-107	10.2	-51.2	-23.83
					Margin (dB)	-27.37
7	2330.153	47.42dBuV Pk	-107	10.4	-49.18	-23.83
					Margin (dB)	-25.35
8	2437.44	92.55dBuV Pk	-107	10.5	-3.95	-3.83
					Margin (dB)	-.12
9	3817.59	51.81dBuV Pk	-107	10.8	-44.39	-23.83
					Margin (dB)	-20.56
10	25641.675	54.5dBuV Pk	-107	11.8	-40.7	-23.83
					Margin (dB)	-16.87
High Channel						
11	610.254	45.95dBuV Pk	-107	10.2	-50.85	-23.83
					Margin (dB)	-27.02
12	2083.288	47.24dBuV Pk	-107	10.4	-49.36	-23.83
					Margin (dB)	-25.53
13	2463.48	92.67dBuV Pk	-107	10.5	-3.83	-3.83
					Margin (dB)	0
14	3820.715	52.6dBuV Pk	-107	10.8	-43.6	-23.83
					Margin (dB)	-19.77
15	25660.425	55.02dBuV Pk	-107	11.7	-40.28	-23.83
					Margin (dB)	-16.45

LIMIT 1: Limit
 Pk - Peak detector

9. RADIATED TEST RESULTS

9.1. LIMITS AND PROCEDURE

LIMITS

FCC §15.205, §15.209, §15.247 (d)

IC RSS-GEN Clause 8.9 (Transmitter)

Frequency Range (MHz)	Field Strength Limit (uV/m) at 3 m	Field Strength Limit (dBuV/m) at 3 m
0.009-0.490	2400/F(kHz) @ 300 m	-
0.490-1.705	24000/F(kHz) @ 30 m	-
1.705 - 30	30 @ 30m	-
30 - 88	100	40
88 - 216	150	43.5
216 - 960	200	46
Above 960	500	54

TEST PROCEDURE

The EUT is placed on a non-conducting table 80 cm above the ground plane for below 1GHz measurements and 1.5 m above the ground plane for above 1GHz measurements. The antenna to EUT distance is 3 meters.

For measurements below 1 GHz the resolution bandwidth is set to 120 kHz for peak detection measurements or 120 kHz for quasi-peak detection measurements for the 30-1000 MHz range, 9 kHz for peak detection measurements or 9 kHz for quasi-peak detection measurements for the 0.15-30 MHz range and 200 Hz for peak detection measurements or 200 Hz for quasi-peak detection measurements for the 9 to 150 kHz range. Peak detection is used unless otherwise noted as quasi-peak.

For peak measurements above 1 GHz, the resolution bandwidth is set to 1 MHz and the video bandwidth is set to 3 MHz. For average measurements above 1GHz, the resolution bandwidth and video bandwidth are set as described in ANSI C63.10:2013 for the applicable measurement. For this evaluation, RMS Power Averaging was used and the resolution/video bandwidth settings were 1MHz/3MHz.

The spectrum from 9 kHz to 30 MHz is investigated with the transmitter set to middle channel in each applicable band.

The spectrum from 30 MHz to 25 GHz is investigated with the transmitter set to the lowest, middle, and highest channels in each applicable band.

The frequency range of interest is monitored at a fixed antenna height and EUT azimuth. The EUT is rotated through 360 degrees to maximize emissions received. The antenna is scanned from 1 to 4 meters above the ground plane to further maximize the emission. Measurements are made with the antenna polarized in both the vertical and the horizontal positions.

9.2. RADIATED TRANSMITTER ABOVE 1 GHz

9.2.1. TX ABOVE 1 GHz 802.11b MODE IN THE 2.4 GHz BAND

RESTRICTED BANDEDGE (LOW CHANNEL)

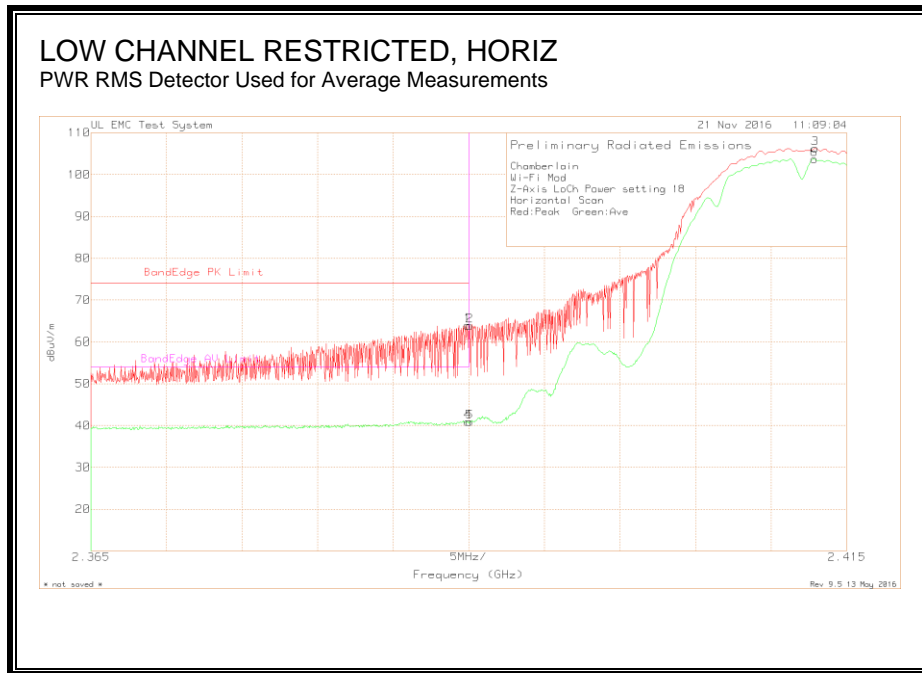

Chamberlain
 Wi-Fi Mod
 Z-Axis LoCh Power setting 18
 Horizontal Scan
 Red:Peak Green:Ave

Trace Markers

Test No.	Frequency (GHz)	Meter Reading	Transducer Factor (dB)	Gain/Loss Factor (dB)	Corrected Reading dBuV/m	Limit:1	2
Peak							
1	2.3899	37.49dBuV Pk	21.8	4.65	63.94	74	-
		Azimuth:35	Height:185	Horz	Margin (dB)	-10.06	-
2	2.39005	37.39dBuV Pk	21.8	4.65	63.84	-	-
		Azimuth:35	Height:185	Horz	Margin (dB)	-	-
3	2.4129	79.8dBuV Pk	21.8	4.65	106.25	-	-
		Azimuth:35	Height:185	Horz	Margin (dB)	-	-
Average							
4	2.38995	14.41dBuV Av	21.8	4.65	40.86	74	54
		Azimuth:35	Height:185	Horz	Margin (dB)	-33.14	-13.14
5	2.39005	14.43dBuV Av	21.8	4.65	40.88	-	-
		Azimuth:35	Height:185	Horz	Margin (dB)	-	-
6	2.41285	77.26dBuV Av	21.8	4.65	103.71	-	-
		Azimuth:35	Height:185	Horz	Margin (dB)	-	-

LIMIT 1: BandEdge PK Limit
 LIMIT 2: BandEdge AV Limit

Pk - Peak detector
 Av - Average detector

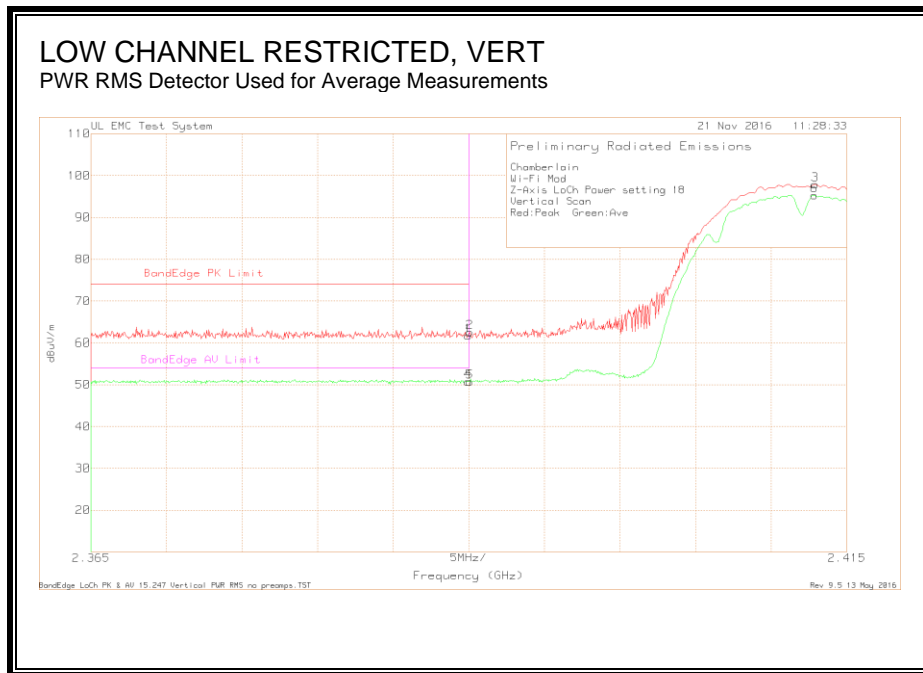

Chamberlain
 Wi-Fi Mod
 Z-Axis LoCh Power setting 18
 Vertical Scan
 Red:Peak Green:Ave

Trace Markers

Test No.	Frequency (GHz)	Meter Reading	Transducer Factor (dB)	Gain/Loss Factor (dB)	Corrected Reading	Limit:1	Limit:2
Peak							
1	2.38995	35.28dBuV Pk	21.8	4.65	61.73	74	-
		Azimuth:109	Height:300	Vert	Margin (dB)	-12.27	-
2	2.39005	36.09dBuV Pk	21.8	4.65	62.54	-	-
		Azimuth:109	Height:300	Vert	Margin (dB)	-	-
3	2.4129	71.44dBuV Pk	21.8	4.65	97.89	-	-
		Azimuth:109	Height:300	Vert	Margin (dB)	-	-
Average							
4	2.38995	24.3dBuV Av	21.8	4.65	50.75	74	54
		Azimuth:109	Height:300	Vert	Margin (dB)	-23.25	-3.25
5	2.39005	24.26dBuV Av	21.8	4.65	50.71	-	-
		Azimuth:109	Height:300	Vert	Margin (dB)	-	-
6	2.41285	68.85dBuV Av	21.8	4.65	95.3	-	-
		Azimuth:109	Height:300	Vert	Margin (dB)	-	-

LIMIT 1: BandEdge PK Limit
 LIMIT 2: BandEdge AV Limit

Pk - Peak detector
 Av - Average Datector

AUTHORIZED BANDEGE (HIGH CHANNEL)

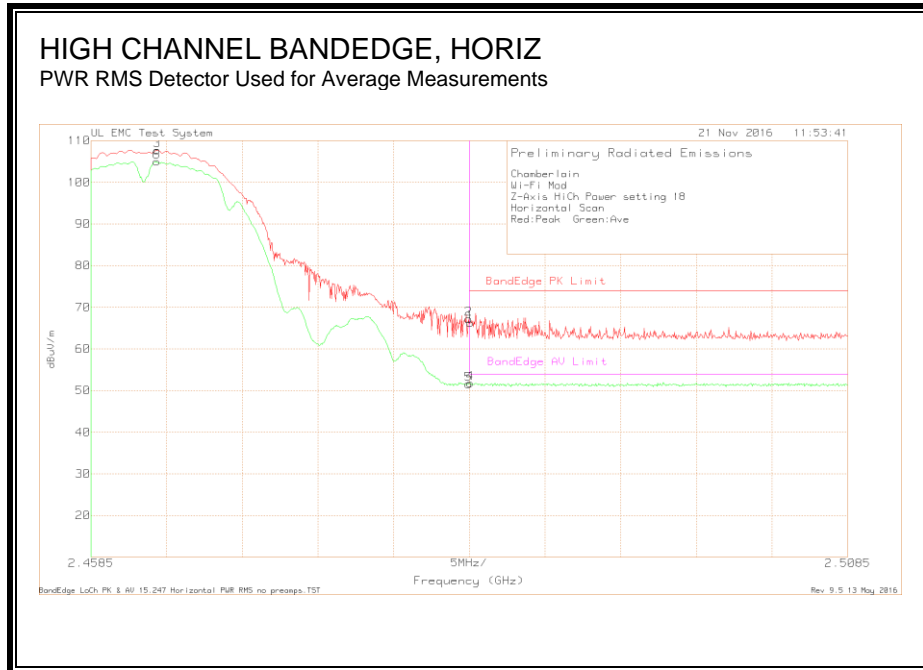

Chamberlain
 Wi-Fi Mod
 Z-Axis HiCh Power setting 18
 Horizontal Scan
 Red:Peak Green:Ave

Trace Markers

Test No.	Frequency (GHz)	Meter Reading	Transducer Factor (dB)	Gain/Loss Factor (dB)	Corrected Reading dBuV/m	Limit:1	2
=====							
Peak							
1	2.48355	39.4dBuV Pk	22.1	4.76	66.26	74	-
		Azimuth:35	Height:176	Horz	Margin (dB)	-7.74	-
2	2.48345	40.36dBuV Pk	22.1	4.76	67.22	-	-
		Azimuth:35	Height:176	Horz	Margin (dB)	-	-
3	2.462875	80.94dBuV Pk	22	4.72	107.66	-	-
		Azimuth:35	Height:176	Horz	Margin (dB)	-	-
Average							
4	2.48355	24.92dBuV Pk	22.1	4.76	51.78	74	54
		Azimuth:35	Height:176	Horz	Margin (dB)	-22.22	-2.22
5	2.48345	24.71dBuV Pk	22.1	4.76	51.57	-	-
		Azimuth:35	Height:176	Horz	Margin (dB)	-	-
6	2.46285	78.26dBuV Pk	22	4.72	104.98	-	-
		Azimuth:35	Height:176	Horz	Margin (dB)	-	-

LIMIT 1: BandEdge PK Limit
 LIMIT 2: BandEdge AV Limit

Pk - Peak detector
 Av - Average detector

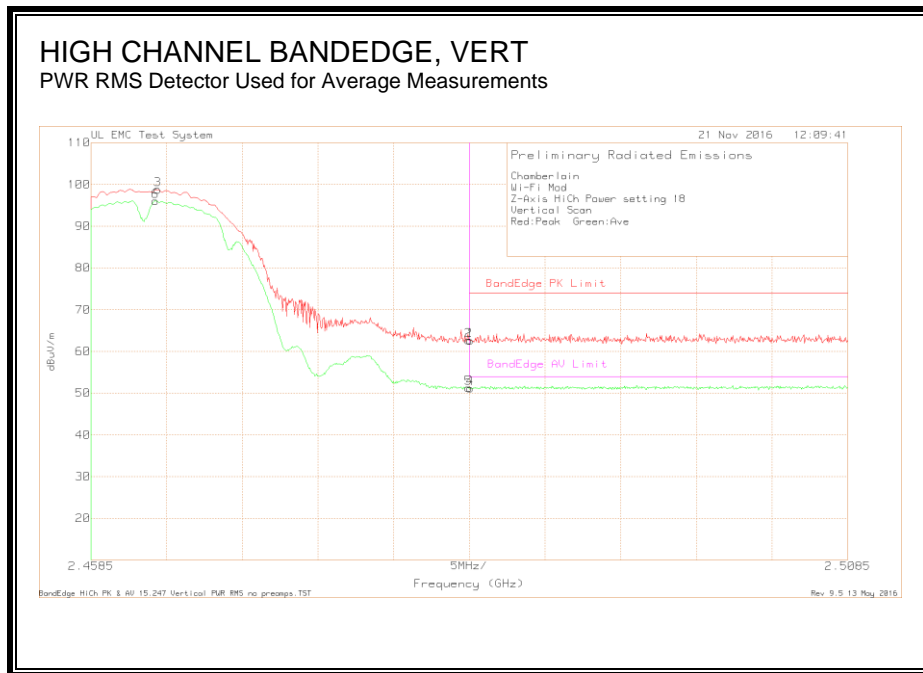

Chamberlain
 Wi-Fi Mod
 Z-Axis HiCh Power setting 18
 Vertical Scan
 Red:Peak Green:Ave

Trace Markers

Test No.	Frequency (GHz)	Meter Reading	Transducer Factor (dB)	Gain/Loss Factor (dB)	Corrected Reading	Limit:1	Limit:2
=====							
Peak							
1	2.48355	35.69dBuV Pk Azimuth:111	22.1	4.76	62.55	74	-
			Height:286	Vert	Margin (dB)	-11.45	-
2	2.48345	35.82dBuV Pk Azimuth:111	22.1	4.76	62.68	-	-
			Height:286	Vert	Margin (dB)	-	-
3	2.4629	72.07dBuV Pk Azimuth:111	22	4.72	98.79	-	-
			Height:286	Vert	Margin (dB)	-	-
Average							
4	2.48355	24.28dBuV Pk Azimuth:111	22.1	4.76	51.14	74	54
			Height:286	Vert	Margin (dB)	-22.86	-2.86
5	2.48345	24.36dBuV Pk Azimuth:111	22.1	4.76	51.22	-	-
			Height:286	Vert	Margin (dB)	-	-
6	2.46275	69.33dBuV Pk Azimuth:111	22	4.72	96.05	-	-
			Height:286	Vert	Margin (dB)	-	-

LIMIT 1: BandEdge PK Limit
 LIMIT 2: BandEdge AV Limit

Pk - Peak detector
 Av - Average Detector

HARMONICS AND SPURIOUS EMISSIONS

Low Channel Plots

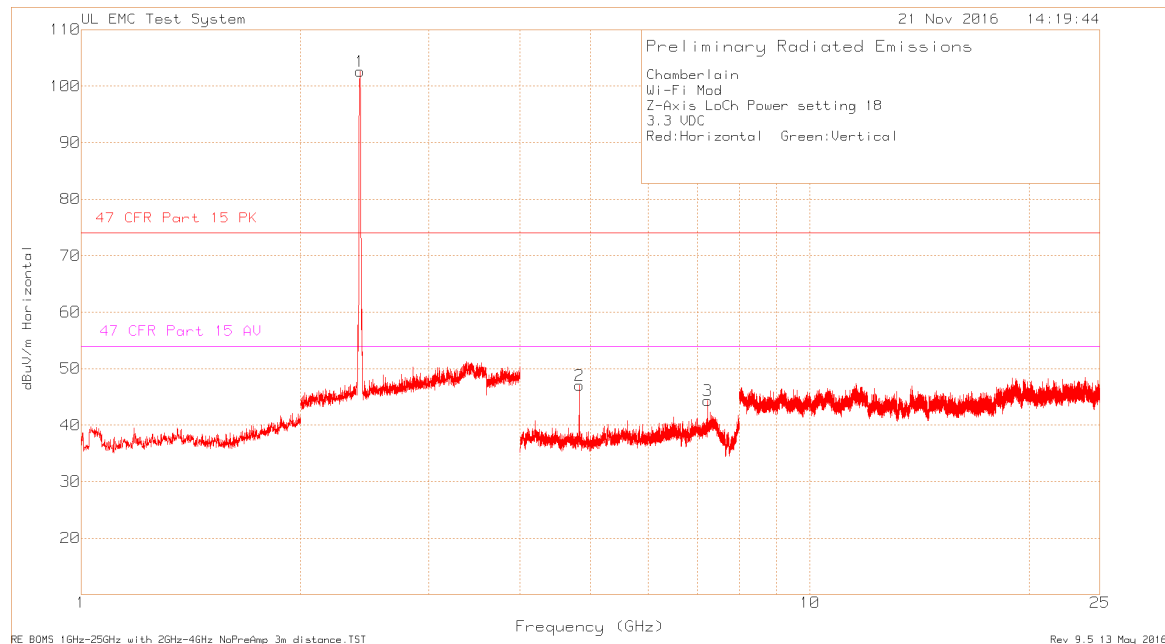
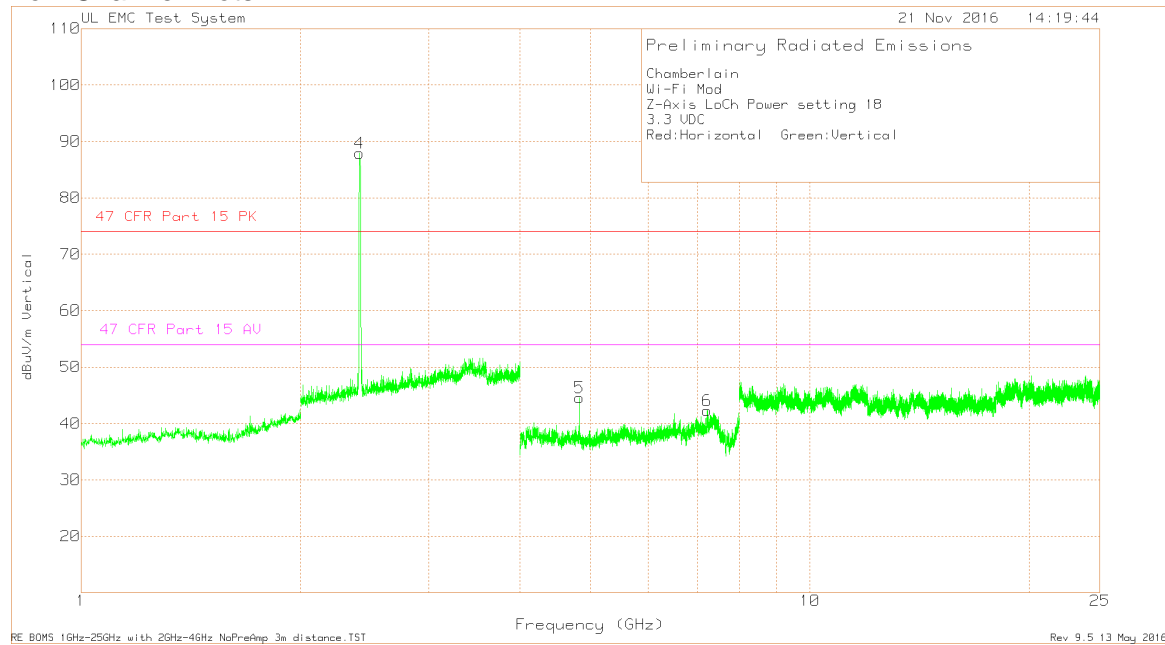

Low Channel Data

Chamberlain
 Wi-Fi Mod
 Z-Axis LoCh Power setting 18
 3.3 VDC
 Red:Horizontal Green:Vertical

Trace Markers

No.	Test Frequency (GHz)	Meter Reading	Transducer Factor (dB)	Gain/Loss Factor (dB)	Corrected Reading dBuV/m	Limit:1	2
1	2.413	76.13dBuV Pk	21.8	4.65	102.58	-	-
		Azimuth:0-360	Height:150	Horz	Margin (dB)	-	-
2	4.824	70.66dBuV Pk	27.7	-51.31	47.05	74	54
		Azimuth:0-360	Height:150	Horz	Margin (dB)	-26.95	-6.95
3	7.236	60.57dBuV Pk	30	-46.25	44.32	74	54
		Azimuth:0-360	Height:150	Horz	Margin (dB)	-29.68	-9.68
4	2.41	61.45dBuV Pk	21.8	4.65	87.9	-	-
		Azimuth:0-360	Height:150	Vert	Margin (dB)	-	-
5	4.824	68.2dBuV Pk	27.7	-51.31	44.59	74	54
		Azimuth:0-360	Height:150	Vert	Margin (dB)	-29.41	-9.41
6	7.226	58.69dBuV Pk	29.9	-46.3	42.29	74	54
		Azimuth:0-360	Height:150	Vert	Margin (dB)	-31.71	-11.71

Pk - Peak detector

Radiated Emission Data

No.	Test Frequency (GHz)	Meter Reading	Transducer Factor (dB)	Gain/Loss Factor (dB)	Corrected Reading dBuV/m	Limit:1	2
4.824		71.36dBuV Pk	27.7	-51.31	47.75	74	54
		Azimuth: 312	Height:223	Horz	Margin (dB):	-26.25	-6.25
4.824		68.63dBuV Av	27.7	-51.31	45.02	74	54
		Azimuth: 312	Height:223	Horz	Margin (dB):	-28.98	-8.98
4.824		72.22dBuV Pk	27.7	-51.31	48.61	74	54
		Azimuth: 215	Height:252	Vert	Margin (dB):	-25.39	-5.39
4.824		69.59dBuV Av	27.7	-51.31	45.98	74	54
		Azimuth: 215	Height:252	Vert	Margin (dB):	-28.02	-8.02
7.2364		62.23dBuV Pk	30	-46.25	45.98	74	54
		Azimuth: 0	Height:187	Horz	Margin (dB):	-28.02	-8.02
7.2353		54.57dBuV Av	30	-46.26	38.31	74	54
		Azimuth: 0	Height:187	Horz	Margin (dB):	-35.69	-15.69
7.2365		60.49dBuV Pk	30	-46.25	44.24	74	54
		Azimuth: 360	Height:212	Vert	Margin (dB):	-29.76	-9.76
7.2353		50.03dBuV Av	30	-46.26	33.77	74	54
		Azimuth: 360	Height:212	Vert	Margin (dB):	-40.23	-20.23

LIMIT 1: 47 CFR Part 15 PK
 LIMIT 2: 47 CFR Part 15 AV

Pk - Peak detector
 Av - Average detection

Middle Channel Plots

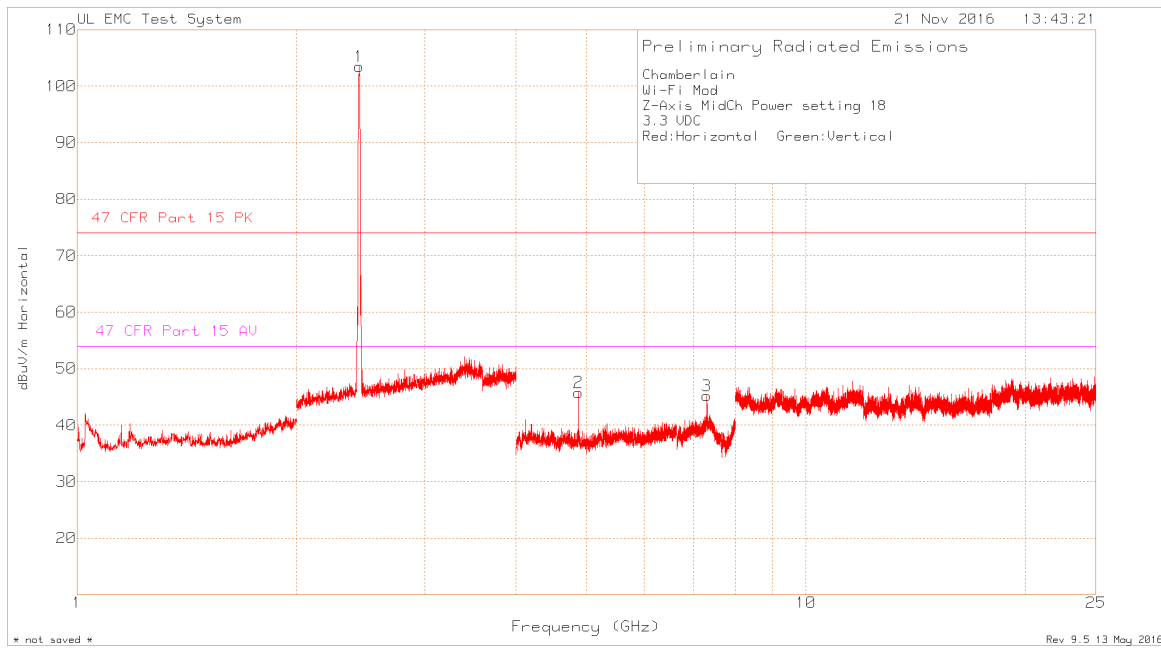
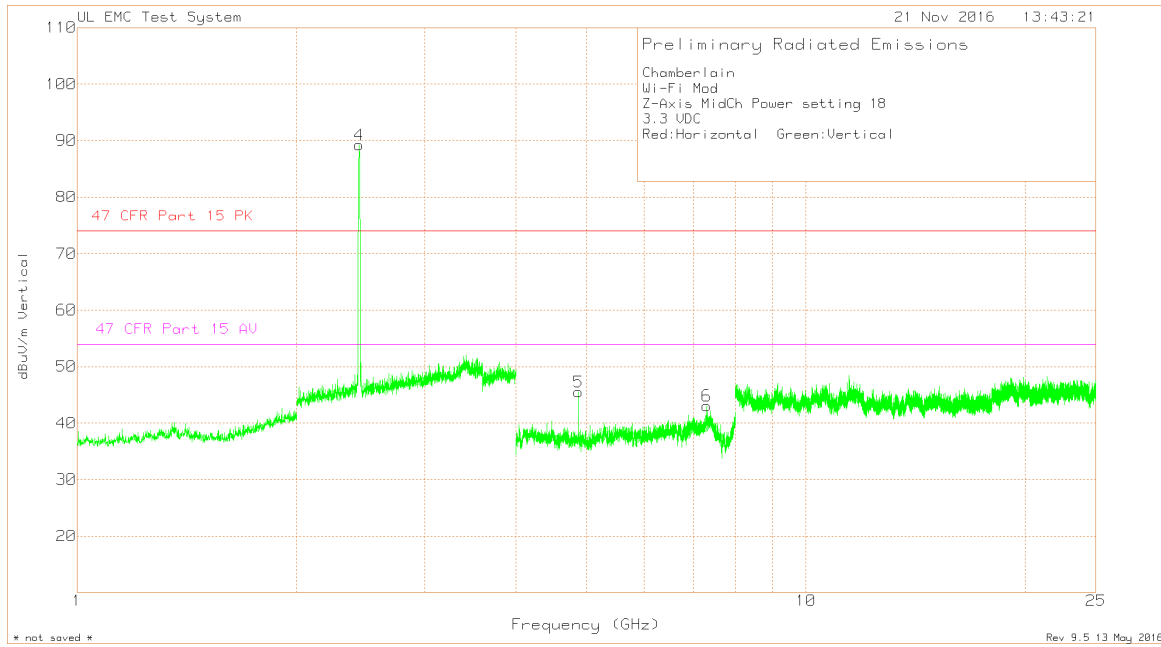

Middle Channel Data

Chamberlain
 Wi-Fi Mod
 Z-Axis MidCh Power setting 18
 3.3 VDC
 Red:Horizontal Green:Vertical

Trace Markers

No.	Test Frequency (GHz)	Meter Reading	Transducer Factor (dB)	Gain/Loss Factor (dB)	Corrected Reading dBuV/m	Limit:1	2
1	2.436	76.88dBuV Pk	21.9	4.72	103.5	-	-
		Azimuth:0-360	Height:150	Horz	Margin (dB)	-	-
2	4.874	68.94dBuV Pk	27.7	-50.85	45.79	74	54
		Azimuth:0-360	Height:150	Horz	Margin (dB)	-28.21	-8.21
3	7.312	60.7dBuV Pk	30.5	-46	45.2	74	54
		Azimuth:0-360	Height:150	Horz	Margin (dB)	-28.8	-8.8
4	2.438	62.62dBuV Pk	21.9	4.72	89.24	-	-
		Azimuth:0-360	Height:150	Vert	Margin (dB)	-	-
5	4.874	68.64dBuV Pk	27.7	-50.85	45.49	74	54
		Azimuth:0-360	Height:150	Vert	Margin (dB)	-28.51	-8.51
6	7.312	58.58dBuV Pk	30.5	-46	43.08	74	54
		Azimuth:0-360	Height:150	Vert	Margin (dB)	-30.92	-10.92

Pk - Peak detector

Radiated Emission Data

No.	Test Frequency (GHz)	Meter Reading	Transducer Factor (dB)	Gain/Loss Factor (dB)	Corrected Reading dBuV/m	Limit:1	2
4.874	309	71.39dBuV Pk	27.7	-50.85	48.24	74	54
		Azimuth: 309	Height:238	Horz	Margin (dB):	-25.76	-5.76
4.874	309	69.22dBuV Av	27.7	-50.85	46.07	74	54
		Azimuth: 309	Height:238	Horz	Margin (dB):	-27.93	-7.93
4.8739	168	70.38dBuV Pk	27.7	-50.85	47.23	74	54
		Azimuth: 168	Height:201	Vert	Margin (dB):	-26.77	-6.77
4.874	168	66.89dBuV Av	27.7	-50.85	43.74	74	54
		Azimuth: 168	Height:201	Vert	Margin (dB):	-30.26	-10.26
7.3117	360	61.81dBuV Pk	30.5	-46	46.31	74	54
		Azimuth: 360	Height:201	Horz	Margin (dB):	-27.69	-7.69
7.3118	360	54.1dBuV Av	30.5	-46	38.6	74	54
		Azimuth: 360	Height:201	Horz	Margin (dB):	-35.4	-15.4
7.3116	317	59.75dBuV Pk	30.5	-46	44.25	74	54
		Azimuth: 317	Height:207	Vert	Margin (dB):	-29.75	-9.75
7.3118	317	50.86dBuV Av	30.5	-46	35.36	74	54
		Azimuth: 317	Height:207	Vert	Margin (dB):	-38.64	-18.64

LIMIT 1: 47 CFR Part 15 PK
 LIMIT 2: 47 CFR Part 15 AV

Pk - Peak detector
 Av - Average detection

High Channel Plot

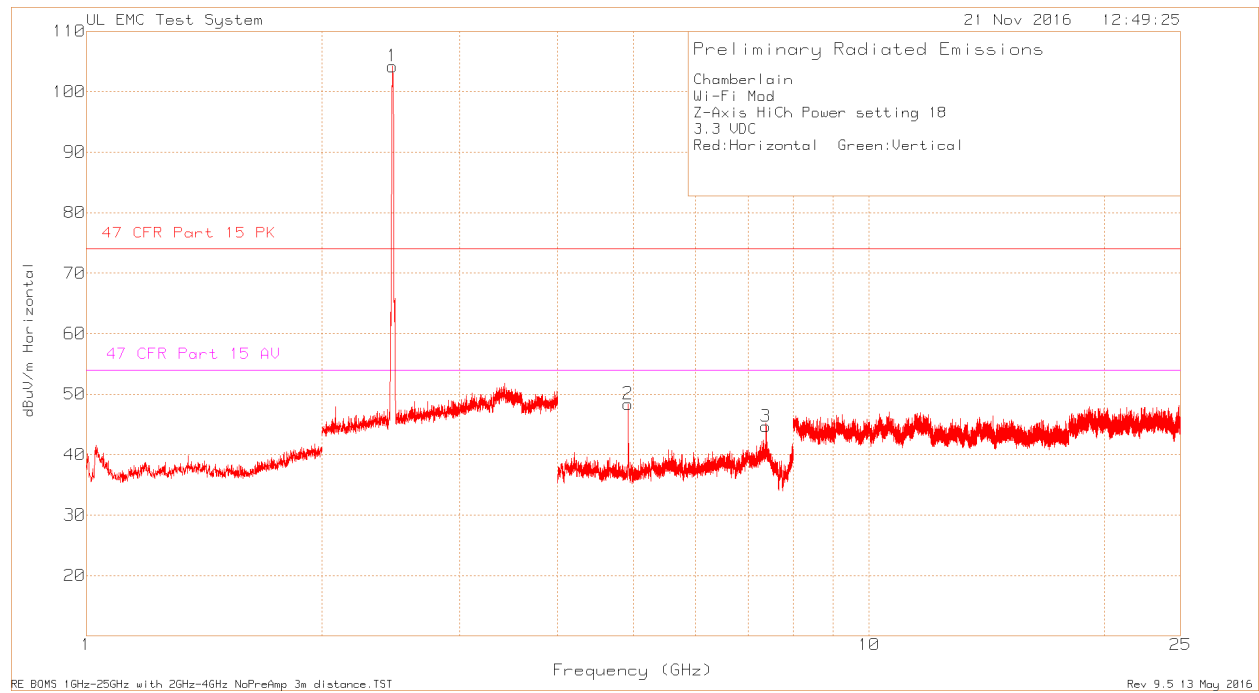
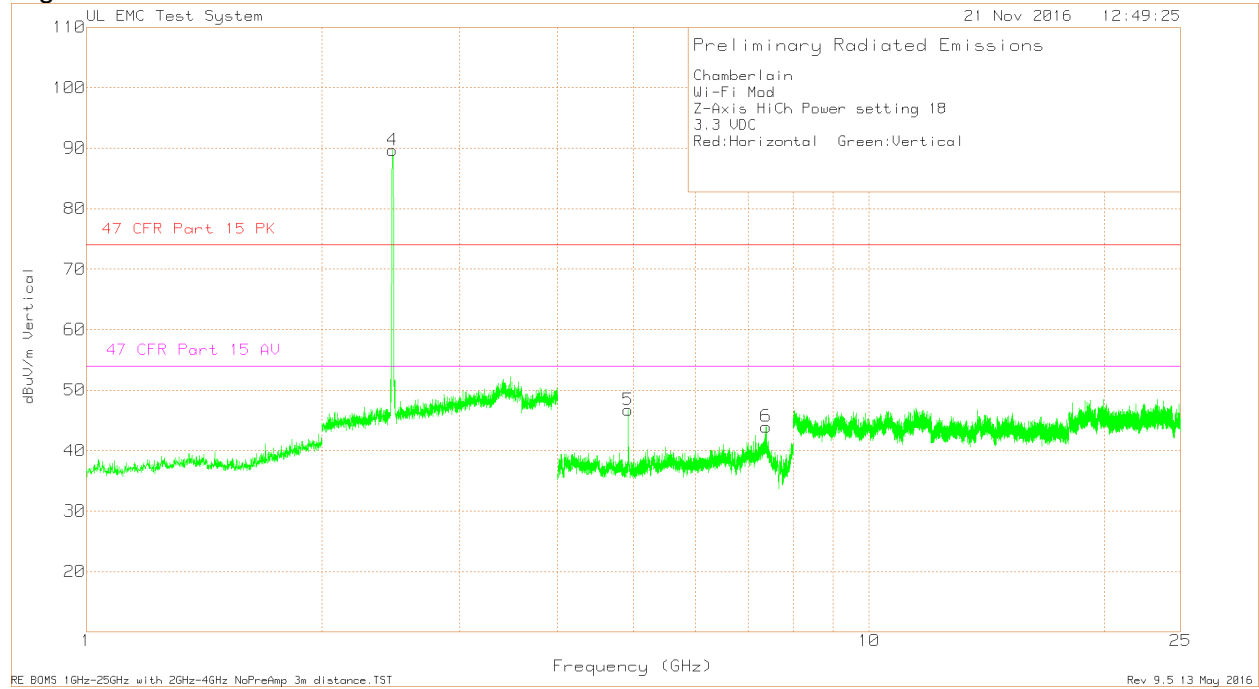

High Channel Data

Chamberlain
 Wi-Fi Mod
 Z-Axis HiCh Power setting 18
 3.3 VDC
 Red:Horizontal Green:Vertical

Trace Markers

No.	Test Frequency (GHz)	Meter Reading	Transducer Factor (dB)	Gain/Loss Factor (dB)	Corrected Reading dBuV/m	Limit:1	2
1	2.461	77.47dBuV Pk	22	4.72	104.19	-	-
		Azimuth:0-360	Height:148	Horz	Margin (dB)	-	-
2	4.924	70.84dBuV Pk	27.8	-50.27	48.37	74	54
		Azimuth:0-360	Height:149	Horz	Margin (dB)	-25.63	-5.63
3	7.385	60.31dBuV Pk	31.1	-46.76	44.65	74	54
		Azimuth:0-360	Height:149	Horz	Margin (dB)	-29.35	-9.35
4	2.461	62.91dBuV Pk	22	4.72	89.63	-	-
		Azimuth:0-360	Height:149	Vert	Margin (dB)	-	-
5	4.924	69.17dBuV Pk	27.8	-50.27	46.7	74	54
		Azimuth:0-360	Height:149	Vert	Margin (dB)	-27.3	-7.3
6	7.387	59.68dBuV Pk	31.1	-46.82	43.96	74	54
		Azimuth:0-360	Height:149	Vert	Margin (dB)	-30.04	-10.04

Pk - Peak detector

Radiated Emission Data

No.	Test Frequency (GHz)	Meter Reading	Transducer Factor (dB)	Gain/Loss Factor (dB)	Corrected Reading dBuV/m	Limit:1	2
4.924		72.68dBuV Pk	27.8	-50.27	50.21	74	54
	Azimuth: 314	Height:212	Horz		Margin (dB):	-23.79	-3.79
4.924		70.23dBuV Av	27.8	-50.27	47.76	74	54
	Azimuth: 314	Height:212	Horz		Margin (dB):	-26.24	-6.24
4.924		71.86dBuV Pk	27.8	-50.27	49.39	74	54
	Azimuth: 167	Height:252	Vert		Margin (dB):	-24.61	-4.61
4.924		69.39dBuV Av	27.8	-50.27	46.92	74	54
	Azimuth: 167	Height:252	Vert		Margin (dB):	-27.08	-7.08
7.3854		61.89dBuV Pk	31.1	-46.77	46.22	74	54
	Azimuth: 360	Height:193	Horz		Margin (dB):	-27.78	-7.78
7.3868		54.37dBuV Av	31.1	-46.81	38.66	74	54
	Azimuth: 360	Height:193	Horz		Margin (dB):	-35.34	-15.34
7.3855		60.2dBuV Pk	31.1	-46.77	44.53	74	54
	Azimuth: 206	Height:181	Vert		Margin (dB):	-29.47	-9.47
7.3867		51.75dBuV Av	31.1	-46.81	36.04	74	54
	Azimuth: 206	Height:181	Vert		Margin (dB):	-37.96	-17.96

LIMIT 1: 47 CFR Part 15 PK
 LIMIT 2: 47 CFR Part 15 AV

Pk - Peak detector
 Av - Average detection

9.2.2. TX ABOVE 1 GHz 802.11g MODE IN THE 2.4 GHz BAND

RESTRICTED BANDEDGE (LOW CHANNEL)

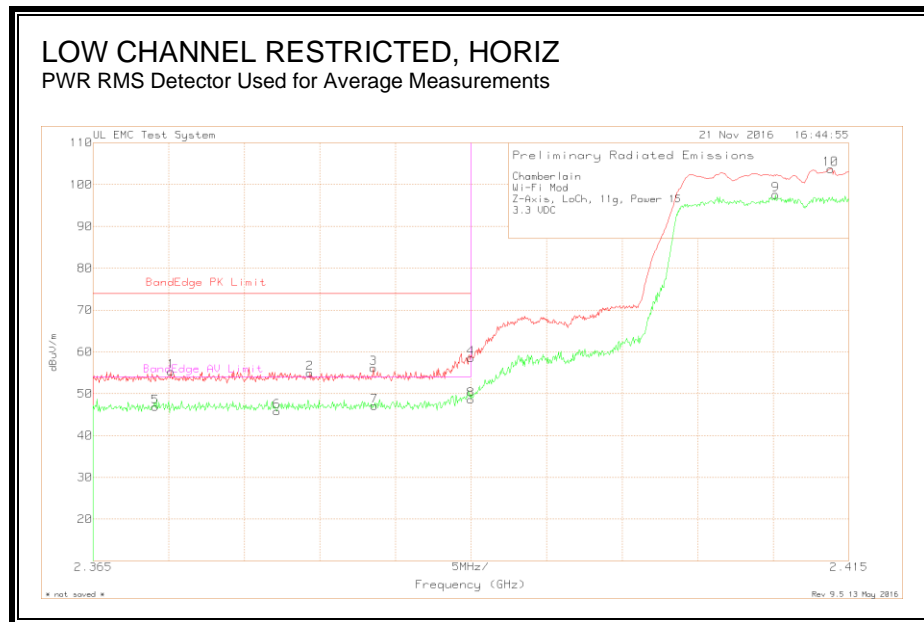

Chamberlain
 Wi-Fi Mod
 Z-Axis, LoCh, 11g, Power 15
 3.3 VDC

Trace Markers

Test No.	Frequency (GHz)	Meter Reading	Transducer Factor (dB)	Gain/Loss Factor (dB)	Corrected Reading	Limit:1	2
=====							
Peak							
1	2.37015	28.92dBuV Pk	21.8	4.63	55.35	74	-
		Azimuth:37	Height:150	Horz	Margin (dB)	-18.65	-
2	2.37935	28.54dBuV Pk	21.8	4.64	54.98	74	-
		Azimuth:37	Height:150	Horz	Margin (dB)	-19.02	-
3	2.38355	29.71dBuV Pk	21.8	4.64	56.15	74	-
		Azimuth:37	Height:150	Horz	Margin (dB)	-17.85	-
4	2.39	32.1dBuV Pk	21.8	4.65	58.55	74	-
		Azimuth:37	Height:150	Horz	Margin (dB)	-15.45	-
10	2.4138	77.3dBuV Pk	21.8	4.65	103.75	-	-
		Azimuth:37	Height:150	Horz	Margin (dB)	-	-
Average							
5	2.3691	20.47dBuV Av	21.8	4.63	46.9	74	54
		Azimuth:37	Height:150	Horz	Margin (dB)	-27.1	-7.1
6	2.37715	19.37dBuV Av	21.8	4.64	45.81	74	54
		Azimuth:37	Height:150	Horz	Margin (dB)	-28.19	-8.19
7	2.3836	20.66dBuV Av	21.8	4.64	47.1	74	54
		Azimuth:37	Height:150	Horz	Margin (dB)	-26.9	-6.9
8	2.39	22.18dBuV Av	21.8	4.65	48.63	74	54
		Azimuth:37	Height:150	Horz	Margin (dB)	-25.37	-5.37
9	2.41015	71.17dBuV Av	21.8	4.65	97.62	-	-
		Azimuth:37	Height:150	Horz	Margin (dB)	-	-

LIMIT 1: BandEdge PK Limit
 LIMIT 2: BandEdge AV Limit
 Pk - Peak detector
 Av - Average Detector

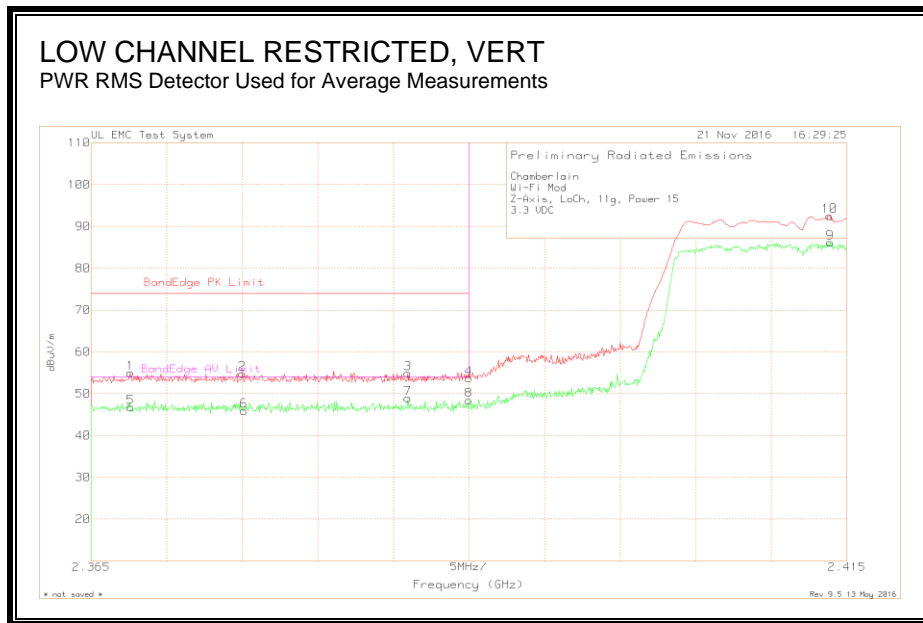

Chamberlain
 Wi-Fi Mod
 Z-Axis, LoCh, 11g, Power 15
 3.3 VDC

Trace Markers

No.	Frequency (GHz)	Meter Reading	Transducer Factor (dB)	Gain/Loss Factor (dB)	Corrected Reading dBuV/m	Limit:1	2
Peak							
1	2.3676	28.55dBuV Pk	21.8	4.63	54.98	74	-
		Azimuth:84	Height:100	Vert	Margin (dB)	-19.02	-
2	2.375	28.35dBuV Pk	21.8	4.64	54.79	74	-
		Azimuth:84	Height:100	Vert	Margin (dB)	-19.21	-
3	2.38595	28.44dBuV Pk	21.8	4.64	54.88	74	-
		Azimuth:84	Height:100	Vert	Margin (dB)	-19.12	-
4	2.39	27.21dBuV Pk	21.8	4.65	53.66	74	-
		Azimuth:84	Height:100	Vert	Margin (dB)	-20.34	-
10	2.41385	66.07dBuV Pk	21.8	4.65	92.52	-	-
		Azimuth:84	Height:100	Vert	Margin (dB)	-	-
Average							
5	2.3676	20.34dBuV Av	21.8	4.63	46.77	74	54
		Azimuth:84	Height:100	Vert	Margin (dB)	-27.23	-7.23
6	2.3751	19.5dBuV Av	21.8	4.64	45.94	74	54
		Azimuth:84	Height:100	Vert	Margin (dB)	-28.06	-8.06
7	2.38595	22.51dBuV Av	21.8	4.64	48.95	74	54
		Azimuth:84	Height:100	Vert	Margin (dB)	-25.05	-5.05
8	2.39	22dBuV Av	21.8	4.65	48.45	74	54
		Azimuth:84	Height:100	Vert	Margin (dB)	-25.55	-5.55
9	2.4139	59.7dBuV Av	21.8	4.65	86.15	-	-
		Azimuth:84	Height:100	Vert	Margin (dB)	-	-

LIMIT 1: BandEdge PK Limit
 LIMIT 2: BandEdge AV Limit
 Pk - Peak detector
 Av - Average Detector

AUTHORIZED BANDEGE (HIGH CHANNEL)

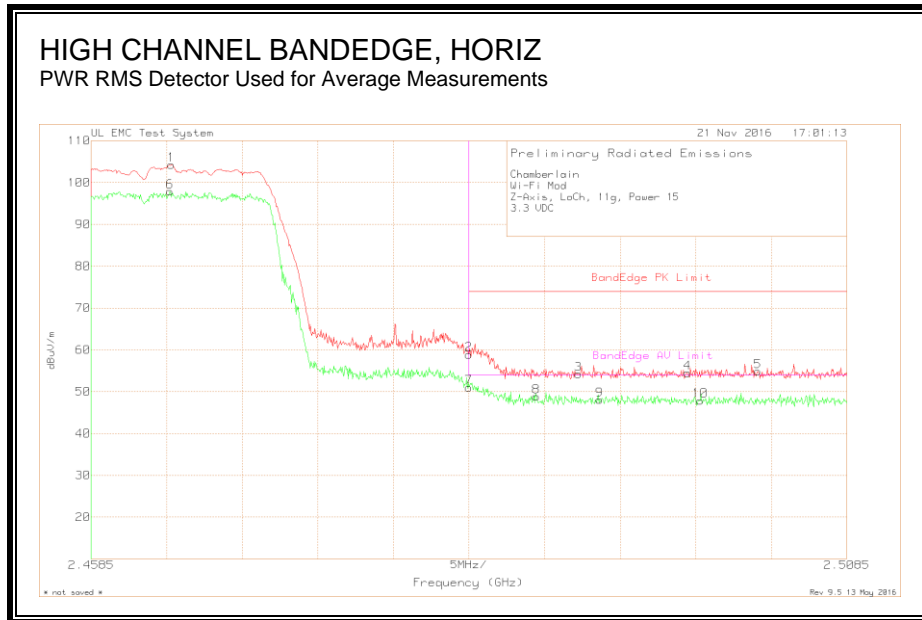

Chamberlain
 Wi-Fi Mod
 Z-Axis, LoCh, 11g, Power 15
 3.3 VDC

Trace Markers

Test No.	Frequency (GHz)	Meter Reading	Transducer Factor (dB)	Gain/Loss Factor (dB)	Corrected Reading	Limit:1 (dB)	2
Peak							
1	2.4638	77.57dBuV Pk	22	4.72	104.29	-	-
		Azimuth:36	Height:175	Horz	Margin (dB)	-	-
2	2.4835	32.04dBuV Pk	22.1	4.76	58.9	74	-
		Azimuth:36	Height:175	Horz	Margin (dB)	-15.1	-
3	2.49075	27.37dBuV Pk	22.1	4.75	54.22	74	-
		Azimuth:36	Height:175	Horz	Margin (dB)	-19.78	-
4	2.49795	27.58dBuV Pk	22.1	4.81	54.49	74	-
		Azimuth:36	Height:175	Horz	Margin (dB)	-19.51	-
5	2.5026	27.95dBuV Pk	22.1	4.82	54.87	74	-
		Azimuth:36	Height:175	Horz	Margin (dB)	-19.13	-
Average							
6	2.4637	71.14dBuV Av	22	4.72	97.86	-	-
		Azimuth:36	Height:175	Horz	Margin (dB)	-	-
7	2.4835	24.15dBuV Av	22.1	4.76	51.01	74	54
		Azimuth:36	Height:175	Horz	Margin (dB)	-22.99	-2.99
8	2.48795	21.99dBuV Av	22.1	4.76	48.85	74	54
		Azimuth:36	Height:175	Horz	Margin (dB)	-25.15	-5.15
9	2.49215	21.18dBuV Av	22.1	4.76	48.04	74	54
		Azimuth:36	Height:175	Horz	Margin (dB)	-25.96	-5.96
10	2.4988	20.98dBuV Av	22.1	4.81	47.89	74	54
		Azimuth:36	Height:175	Horz	Margin (dB)	-26.11	-6.11

LIMIT 1: BandEdge PK Limit
 LIMIT 2: BandEdge AV Limit

Pk - Peak detector
 Av - Average Detector

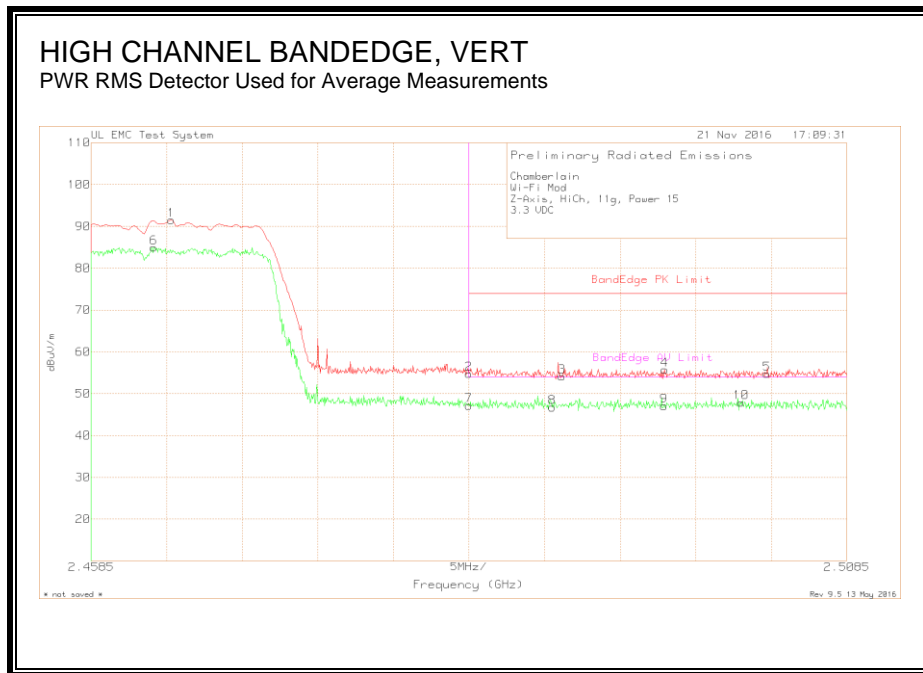

Chamberlain
 Wi-Fi Mod
 Z-Axis, HiCh, 11g, Power 15
 3.3 VDC

Trace Markers

Test No.	Frequency (GHz)	Meter Reading	Transducer Factor (dB)	Gain/Loss Factor (dB)	Corrected Reading	Limit:1	Limit:2
					dBuV/m	dB	dB
=====							
Peak							
1	2.4638	64.79dBuV Pk	22	4.72	91.51	-	-
		Azimuth:38	Height:214	Vert	Margin (dB)	-	-
2	2.4835	27.86dBuV Pk	22.1	4.76	54.72	74	-
		Azimuth:38	Height:214	Vert	Margin (dB)	-19.28	-
3	2.48965	27.27dBuV Pk	22.1	4.75	54.12	74	-
		Azimuth:38	Height:214	Vert	Margin (dB)	-19.88	-
4	2.49645	28.85dBuV Pk	22.1	4.79	55.74	74	-
		Azimuth:38	Height:214	Vert	Margin (dB)	-18.26	-
5	2.5032	27.83dBuV Pk	22.1	4.82	54.75	74	-
		Azimuth:38	Height:214	Vert	Margin (dB)	-19.25	-
Average							
6	2.46265	58.23dBuV Av	22	4.72	84.95	-	-
		Azimuth:38	Height:214	Vert	Margin (dB)	-	-
7	2.4835	20.31dBuV Av	22.1	4.76	47.17	74	54
		Azimuth:38	Height:214	Vert	Margin (dB)	-26.83	-6.83
8	2.489	19.88dBuV Av	22.1	4.76	46.74	74	54
		Azimuth:38	Height:214	Vert	Margin (dB)	-27.26	-7.26
9	2.4964	20.17dBuV Av	22.1	4.79	47.06	74	54
		Azimuth:38	Height:214	Vert	Margin (dB)	-26.94	-6.94
10	2.5015	20.99dBuV Av	22.1	4.82	47.91	74	54
		Azimuth:38	Height:214	Vert	Margin (dB)	-26.09	-6.09

LIMIT 1: BandEdge PK Limit
 LIMIT 2: BandEdge AV Limit

Pk - Peak detector
 Av - Average Detector

HARMONICS AND SPURIOUS EMISSIONS

Low Channel Plot

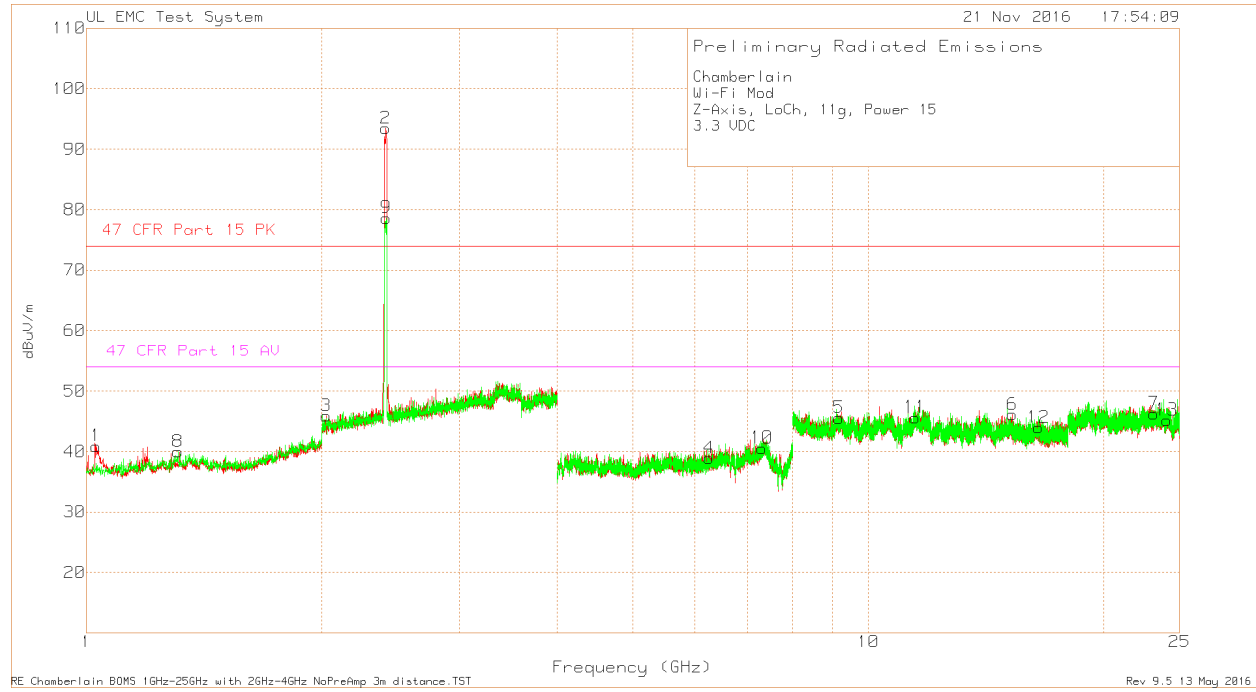

Low Channel Data

Chamberlain
 Wi-Fi Mod
 Z-Axis, LoCh, 11g, Power 15
 3.3 VDC

Trace Markers

Test No.	Frequency (GHz)	Meter Reading	Transducer Factor (dB)	Gain/Loss Factor (dB)	Corrected Reading	Limit:1	2
					dBuV/m		
1	1.028	70.84dBuV Pk	27.5	-57.44	40.9	74	54
		Azimuth:0-360	Height:151	Horz	Margin (dB)	-33.1	-13.1
2	2.415	67.01dBuV Pk	21.8	4.65	93.46	-	-
		Azimuth:0-360	Height:151	Horz	Margin (dB)	-	-
3	2.027	20.16dBuV Pk	21.3	4.45	45.91	74	54
		Azimuth:0-360	Height:151	Horz	Margin (dB)	-28.09	-8.09
4	6.253	57.7dBuV Pk	29.2	-48.01	38.89	74	54
		Azimuth:0-360	Height:151	Horz	Margin (dB)	-35.11	-15.11
5	9.167	57.55dBuV Pk	36.3	-48.3	45.55	74	54
		Azimuth:0-360	Height:151	Horz	Margin (dB)	-28.45	-8.45
6	15.281	46.87dBuV Pk	40	-40.74	46.13	74	54
		Azimuth:0-360	Height:151	Horz	Margin (dB)	-27.87	-7.87
7	23.177	50.86dBuV Pk	40.3	-44.89	46.27	74	54
		Azimuth:0-360	Height:151	Horz	Margin (dB)	-27.73	-7.73
8	1.309	68.07dBuV Pk	28.9	-56.97	40	74	54
		Azimuth:0-360	Height:151	Vert	Margin (dB)	-34	-14
9	2.418	52.08dBuV Pk	21.9	4.66	78.64	-	-
		Azimuth:0-360	Height:151	Vert	Margin (dB)	-	-
10	7.31	56.06dBuV Pk	30.5	-45.99	40.57	74	54
		Azimuth:0-360	Height:151	Vert	Margin (dB)	-33.43	-13.43
11	11.477	54.92dBuV Pk	37.1	-46.38	45.64	74	54
		Azimuth:0-360	Height:151	Vert	Margin (dB)	-28.36	-8.36
12	16.504	45.02dBuV Pk	39.7	-40.78	43.94	74	54
		Azimuth:0-360	Height:151	Vert	Margin (dB)	-30.06	-10.06
13	24.085	50.92dBuV Pk	40.3	-46.03	45.19	74	54
		Azimuth:0-360	Height:151	Vert	Margin (dB)	-28.81	-8.81

LIMIT 1: 47 CFR Part 15 PK
 LIMIT 2: 47 CFR Part 15 AV

Pk - Peak detector

Middle Channel Plot

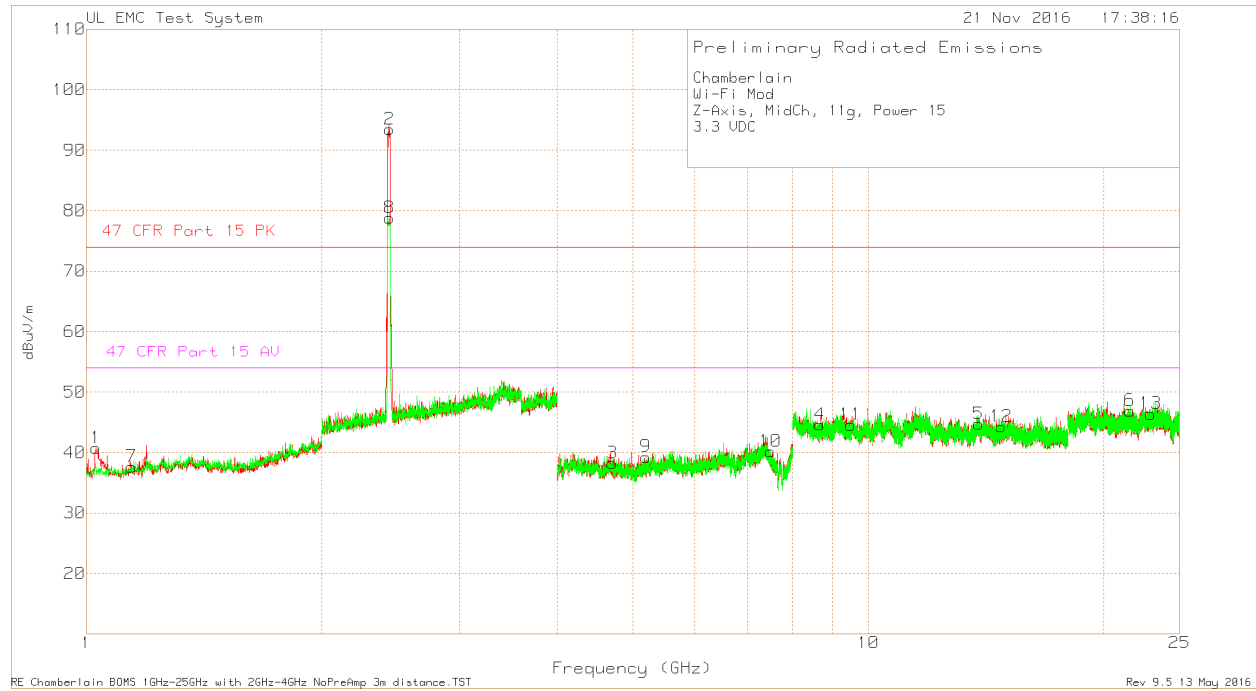

Middle Channel Data

Chamberlain
 Wi-Fi Mod
 Z-Axis, MidCh, 11g, Power 15
 3.3 VDC

Trace Markers

No.	Test Frequency (GHz)	Meter Reading	Transducer Factor (dB)	Gain/Loss Factor (dB)	Corrected Reading	Limit:1 dBuV/m	2
1	1.028	70.66dBuV Pk Azimuth:0-360	27.5	-57.44	40.72	74	54
2	2.443	66.86dBuV Pk Azimuth:0-360	21.9	4.72	93.48	-33.28	-13.28
3	4.704	62.1dBuV Pk Azimuth:0-360	27.7	-51.57	38.23	74	54
4	8.671	57.88dBuV Pk Azimuth:0-360	36.4	-49.67	44.61	74	54
5	13.828	47.75dBuV Pk Azimuth:0-360	39.9	-42.9	44.75	74	54
6	21.586	52.65dBuV Pk Azimuth:0-360	40.3	-46.02	46.93	74	54
7	1.142	67.13dBuV Pk Azimuth:0-360	27.9	-57.38	37.65	74	54
8	2.442	52.2dBuV Pk Azimuth:0-360	21.9	4.72	78.82	-36.35	-16.35
9	5.19	60.86dBuV Pk Azimuth:0-360	28.3	-49.88	39.28	74	54
10	7.49	57.7dBuV Pk Azimuth:0-360	29.8	-47.33	40.17	74	54
11	9.489	57.4dBuV Pk Azimuth:0-360	36.4	-49.22	44.58	74	54
12	14.789	45.42dBuV Pk Azimuth:0-360	39.8	-40.92	44.3	74	54
13	22.962	51.2dBuV Pk Azimuth:0-360	40.3	-45.09	46.41	74	54
					Margin (dB)	-29.39	-9.39
					Margin (dB)	-29.25	-9.25
					Margin (dB)	-27.07	-7.07
					Margin (dB)	-34.72	-14.72
					Margin (dB)	-33.83	-13.83
					Margin (dB)	-29.42	-9.42
					Margin (dB)	-29.7	-9.7
					Margin (dB)	-27.59	-7.59

LIMIT 1: 47 CFR Part 15 PK
 LIMIT 2: 47 CFR Part 15 AV

Pk - Peak detector

High Channel Plot

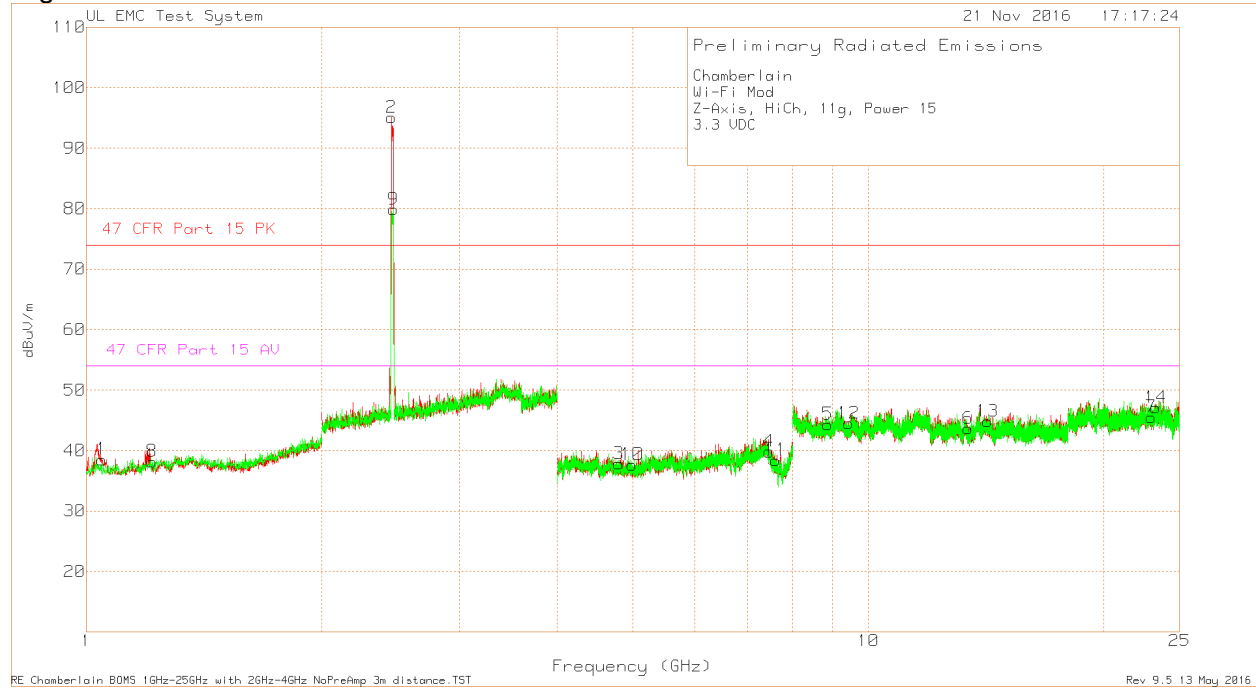

High Channel Data

Chamberlain
 Wi-Fi Mod
 Z-Axis, HiCh, 11g, Power 15
 3.3 VDC

Trace Markers

No.	Test Frequency (GHz)	Meter Reading	Transducer Factor (dB)	Gain/Loss Factor (dB)	Corrected Reading	Limit:1	2
1	1.047	68.68dBuV Pk	27.5	-57.65	38.53	74	54
		Azimuth:0-360	Height:151	Horz	Margin (dB)	-35.47	-15.47
2	2.456	68.37dBuV Pk	22	4.71	95.08	-	-
		Azimuth:0-360	Height:151	Horz	Margin (dB)	-	-
3	4.795	61.7dBuV Pk	27.7	-51.59	37.81	74	54
		Azimuth:0-360	Height:151	Horz	Margin (dB)	-36.19	-16.19
4	7.469	57.03dBuV Pk	30.1	-47.3	39.83	74	54
		Azimuth:0-360	Height:151	Horz	Margin (dB)	-34.17	-14.17
5	8.87	57.5dBuV Pk	36.2	-49.36	44.34	74	54
		Azimuth:0-360	Height:151	Horz	Margin (dB)	-29.66	-9.66
6	13.411	48.2dBuV Pk	39.8	-44.35	43.65	74	54
		Azimuth:0-360	Height:151	Horz	Margin (dB)	-30.35	-10.35
7	23.004	50.16dBuV Pk	40.3	-44.92	45.54	74	54
		Azimuth:0-360	Height:151	Horz	Margin (dB)	-28.46	-8.46
8	1.213	66.98dBuV Pk	28.4	-57.2	38.18	74	54
		Azimuth:0-360	Height:151	Vert	Margin (dB)	-35.82	-15.82
9	2.468	53.16dBuV Pk	22	4.71	79.87	-	-
		Azimuth:0-360	Height:151	Vert	Margin (dB)	-	-
10	4.991	59.79dBuV Pk	27.8	-49.93	37.66	74	54
		Azimuth:0-360	Height:151	Vert	Margin (dB)	-36.34	-16.34
11	7.609	57.42dBuV Pk	28	-47.02	38.4	74	54
		Azimuth:0-360	Height:151	Vert	Margin (dB)	-35.6	-15.6
12	9.435	57.07dBuV Pk	36.4	-48.96	44.51	74	54
		Azimuth:0-360	Height:151	Vert	Margin (dB)	-29.49	-9.49
13	14.205	47.32dBuV Pk	39.9	-42.41	44.81	74	54
		Azimuth:0-360	Height:151	Vert	Margin (dB)	-29.19	-9.19
14	23.308	51.38dBuV Pk	40.3	-44.56	47.12	74	54
		Azimuth:0-360	Height:151	Vert	Margin (dB)	-26.88	-6.88

LIMIT 1: 47 CFR Part 15 PK
 LIMIT 2: 47 CFR Part 15 AV

Pk - Peak detector

9.2.3. TX ABOVE 1 GHz 802.11n HT20 MODE IN THE 2.4 GHz BAND

RESTRICTED BANDEDGE (LOW CHANNEL)

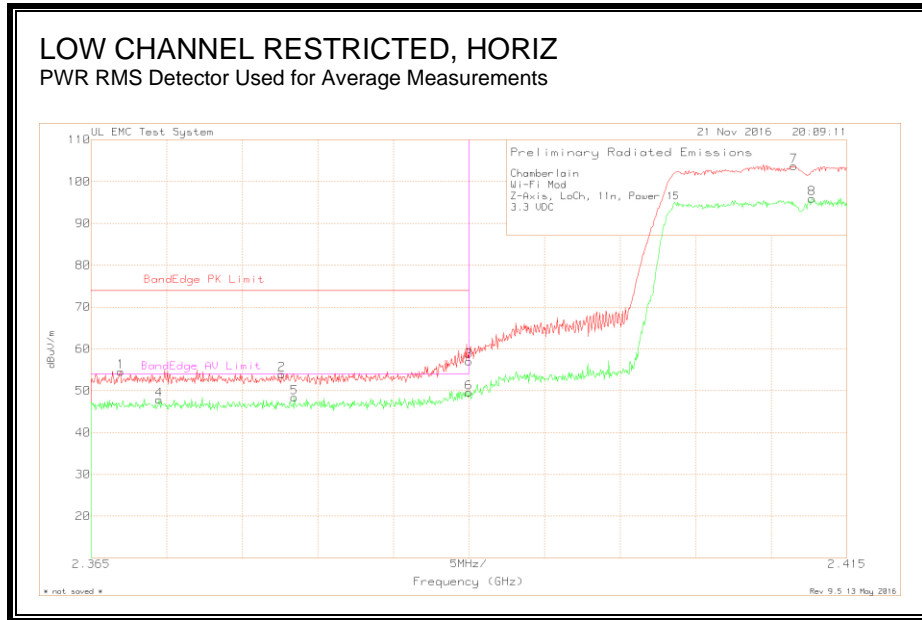

Chamberlain
 Wi-Fi Mod
 Z-Axis, LoCh, 11n, Power 15
 3.3 VDC

Trace Markers

Test No.	Frequency (GHz)	Meter Reading	Transducer Factor (dB)	Gain/Loss Factor (dB)	Corrected Reading	Limit:1 (dB)	Limit:2 (dB)
Peak							
1	2.36695	28.14dBuV Pk	21.8	4.63	54.57	74	-
		Azimuth:38	Height:150	Horz	Margin (dB)	-19.43	-
2	2.3776	27.5dBuV Pk	21.8	4.64	53.94	74	-
		Azimuth:38	Height:150	Horz	Margin (dB)	-20.06	-
3	2.39	30.62dBuV Pk	21.8	4.65	57.07	74	-
		Azimuth:38	Height:150	Horz	Margin (dB)	-16.93	-
7	2.4115	77.28dBuV Pk	21.8	4.65	103.73	-	-
		Azimuth:38	Height:150	Horz	Margin (dB)	-	-
Average							
4	2.3695	21.42dBuV Av	21.8	4.63	47.85	74	54
		Azimuth:38	Height:150	Horz	Margin (dB)	-26.15	-6.15
5	2.37845	21.97dBuV Av	21.8	4.64	48.41	74	54
		Azimuth:38	Height:150	Horz	Margin (dB)	-25.59	-5.59
6	2.39	23.13dBuV Av	21.8	4.65	49.58	74	54
		Azimuth:38	Height:150	Horz	Margin (dB)	-24.42	-4.42
8	2.4127	69.52dBuV Av	21.8	4.65	95.97	-	-
		Azimuth:38	Height:150	Horz	Margin (dB)	-	-

LIMIT 1: BandEdge PK Limit
 LIMIT 2: BandEdge AV Limit

Pk - Peak detector
 AV - Average Detector

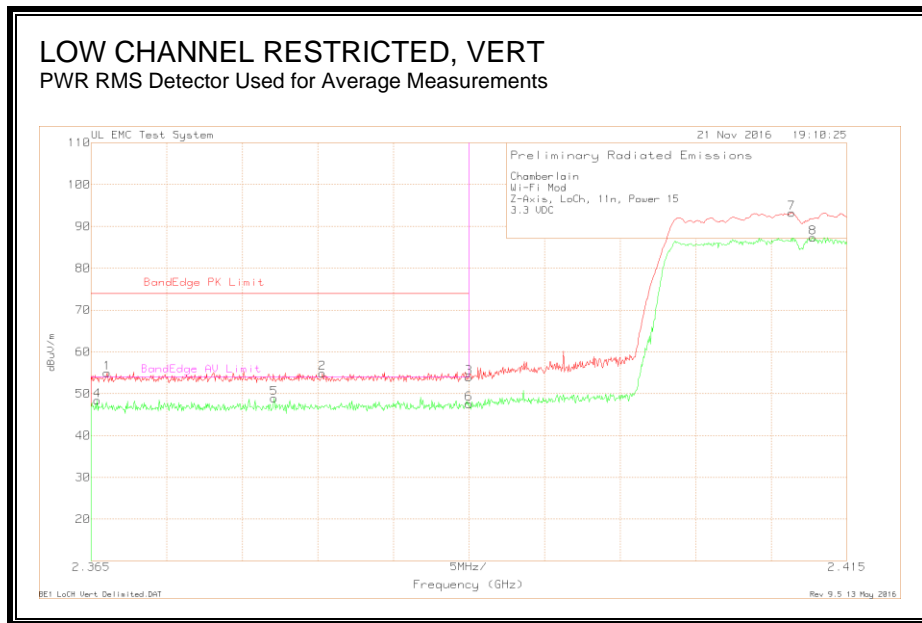

Chamberlain
 Wi-Fi Mod
 Z-Axis, LoCh, 11n, Power 15
 3.3 VDC

Trace Markers

Test No.	Frequency (GHz)	Meter Reading	Transducer Factor (dB)	Gain/Loss Factor (dB)	Corrected Reading	Limit:1	Limit:2
Peak							
1	2.36605	28.51dBuV Pk	21.8	4.63	54.94	74	-
		Azimuth:108	Height:297	Vert	Margin (dB)	-19.06	-
2	2.3803	28.48dBuV Pk	21.8	4.64	54.92	74	-
		Azimuth:108	Height:297	Vert	Margin (dB)	-19.08	-
3	2.39	27.41dBuV Pk	21.8	4.65	53.86	74	-
		Azimuth:108	Height:297	Vert	Margin (dB)	-20.14	-
7	2.41135	66.82dBuV Pk	21.8	4.65	93.27	-	-
		Azimuth:108	Height:297	Vert	Margin (dB)	-	-
Average							
4	2.3654	21.97dBuV Av	21.8	4.63	48.4	74	54
		Azimuth:108	Height:297	Vert	Margin (dB)	-25.6	-5.6
5	2.3771	22.51dBuV Av	21.8	4.64	48.95	74	54
		Azimuth:108	Height:297	Vert	Margin (dB)	-25.05	-5.05
6	2.39	21.15dBuV Av	21.8	4.65	47.6	74	54
		Azimuth:108	Height:297	Vert	Margin (dB)	-26.4	-6.4
8	2.41275	60.88dBuV Av	21.8	4.65	87.33	-	-
		Azimuth:108	Height:297	Vert	Margin (dB)	-	-

LIMIT 1: BandEdge PK Limit
 LIMIT 2: BandEdge AV Limit

Pk - Peak detector
 Av - Average detector

AUTHORIZED BANDEGE (HIGH CHANNEL)

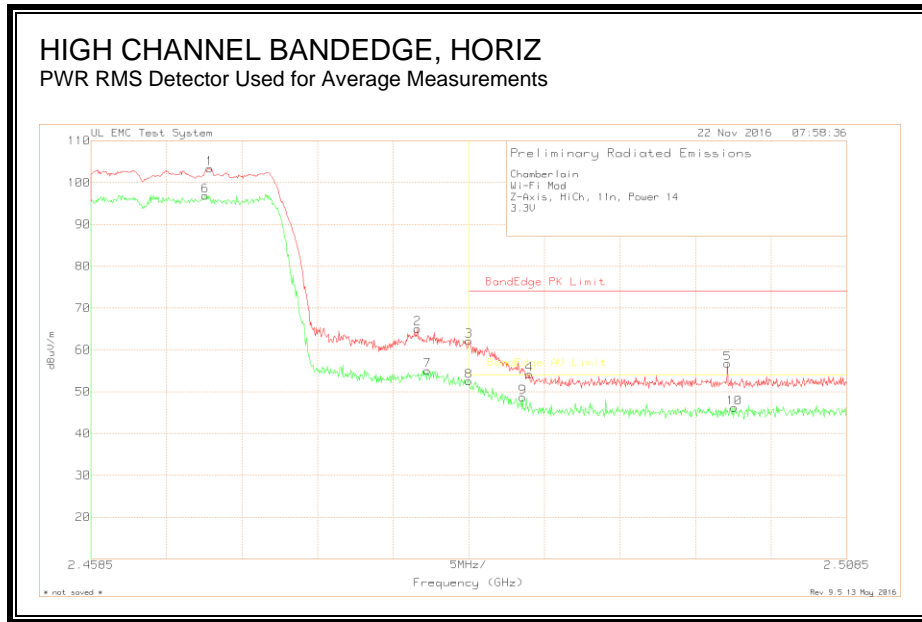

Chamberlain
 Wi-Fi Mod
 Z-Axis, HiCh, 11n, Power 14
 3.3V

Trace Markers

No.	Test Frequency (GHz)	Meter Reading	Transducer Factor (dB)	Gain/Loss Factor (dB)	Corrected Reading	Limit:1	2
					dBuV/m		
Peak							
1	2.46635	76.68dBuV Pk	22	4.72	103.4	-	-
		Azimuth:330	Height:150	Horz	Margin (dB)	-	-
2	2.4801	38.37dBuV Pk	22	4.74	65.11	-	-
		Azimuth:330	Height:150	Horz	Margin (dB)	-	-
3	2.4835	35.33dBuV Pk	22.1	4.76	62.19	74	-
		Azimuth:330	Height:150	Horz	Margin (dB)	-11.81	-
4	2.4875	27.34dBuV Pk	22.1	4.76	54.2	74	-
		Azimuth:330	Height:150	Horz	Margin (dB)	-19.8	-
5	2.5006	29.84dBuV Pk	22.1	4.82	56.76	74	-
		Azimuth:330	Height:150	Horz	Margin (dB)	-17.24	-
Average							
6	2.46605	70.15dBuV Av	22	4.72	96.87	-	-
		Azimuth:330	Height:150	Horz	Margin (dB)	-	-
7	2.48075	28.33dBuV Av	22	4.75	55.08	-	-
		Azimuth:330	Height:150	Horz	Margin (dB)	-	-
8	2.4835	25.67dBuV Av	22.1	4.76	52.53	74	54
		Azimuth:330	Height:150	Horz	Margin (dB)	-21.47	-1.47
9	2.48705	21.83dBuV Av	22.1	4.76	48.69	74	54
		Azimuth:330	Height:150	Horz	Margin (dB)	-25.31	-5.31
10	2.50105	19.25dBuV Av	22.1	4.82	46.17	74	54
		Azimuth:330	Height:150	Horz	Margin (dB)	-27.83	-7.83

LIMIT 1: BandEdge PK Limit
 LIMIT 2: BandEdge AV Limit

Pk - Peak detector
 Av - Average Detector

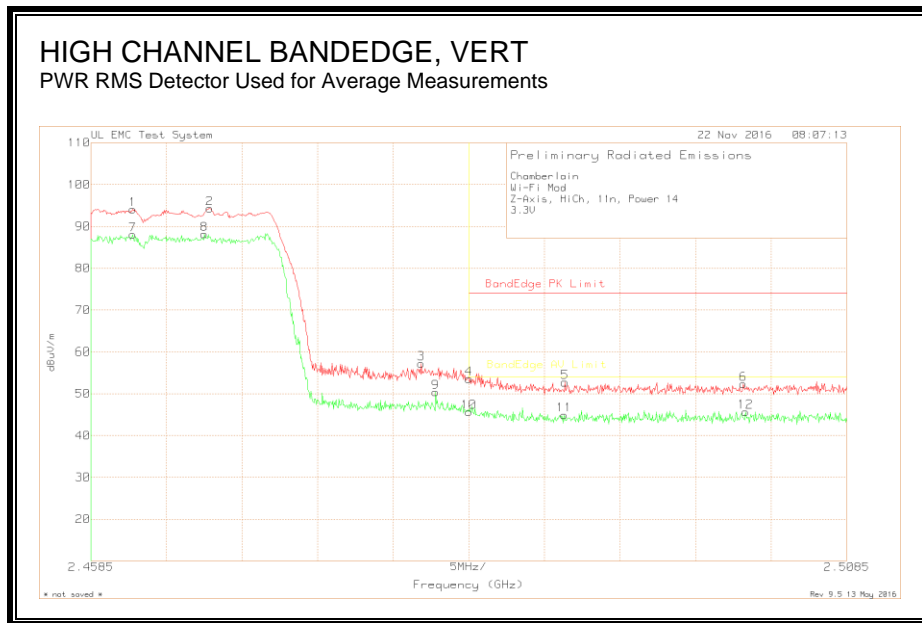

Chamberlain
 Wi-Fi Mod
 Z-Axis, HiCh, 11n, Power 14
 3.3V

Trace Markers

Test No.	Frequency (GHz)	Meter Reading	Transducer Factor (dB)	Gain/Loss Factor (dB)	Corrected Reading dBuV/m	Limit:1	2
=====							
Peak							
1	2.46125	67.35dBuV Pk	22	4.72	94.07	-	-
		Azimuth:38	Height:106	Vert	Margin (dB)	-	-
2	2.46635	67.6dBuV Pk	22	4.72	94.32	-	-
		Azimuth:38	Height:106	Vert	Margin (dB)	-	-
3	2.48035	30.48dBuV Pk	22	4.74	57.22	-	-
		Azimuth:38	Height:106	Vert	Margin (dB)	-	-
4	2.4835	26.72dBuV Pk	22.1	4.76	53.58	74	-
		Azimuth:38	Height:106	Vert	Margin (dB)	-20.42	-
5	2.48985	25.86dBuV Pk	22.1	4.75	52.71	74	-
		Azimuth:38	Height:106	Vert	Margin (dB)	-21.29	-
6	2.50165	25.37dBuV Pk	22.1	4.82	52.29	74	-
		Azimuth:38	Height:106	Vert	Margin (dB)	-21.71	-
Average							
7	2.46125	61.34dBuV Av	22	4.72	88.06	-	-
		Azimuth:38	Height:106	Vert	Margin (dB)	-	-
8	2.466	61.45dBuV Av	22	4.72	88.17	-	-
		Azimuth:38	Height:106	Vert	Margin (dB)	-	-
9	2.4813	23.62dBuV Av	22	4.75	50.37	-	-
		Azimuth:38	Height:106	Vert	Margin (dB)	-	-
10	2.4835	18.74dBuV Av	22.1	4.76	45.6	74	54
		Azimuth:38	Height:106	Vert	Margin (dB)	-28.4	-8.4
11	2.4898	18.08dBuV Av	22.1	4.75	44.93	74	54
		Azimuth:38	Height:106	Vert	Margin (dB)	-29.07	-9.07
12	2.5018	18.76dBuV Av	22.1	4.82	45.68	74	54
		Azimuth:38	Height:106	Vert	Margin (dB)	-28.32	-8.32

LIMIT 1: BandEdge PK Limit
 LIMIT 2: BandEdge AV Limit

Pk - Peak detector

HARMONICS AND SPURIOUS EMISSIONS

Low Channel Plot

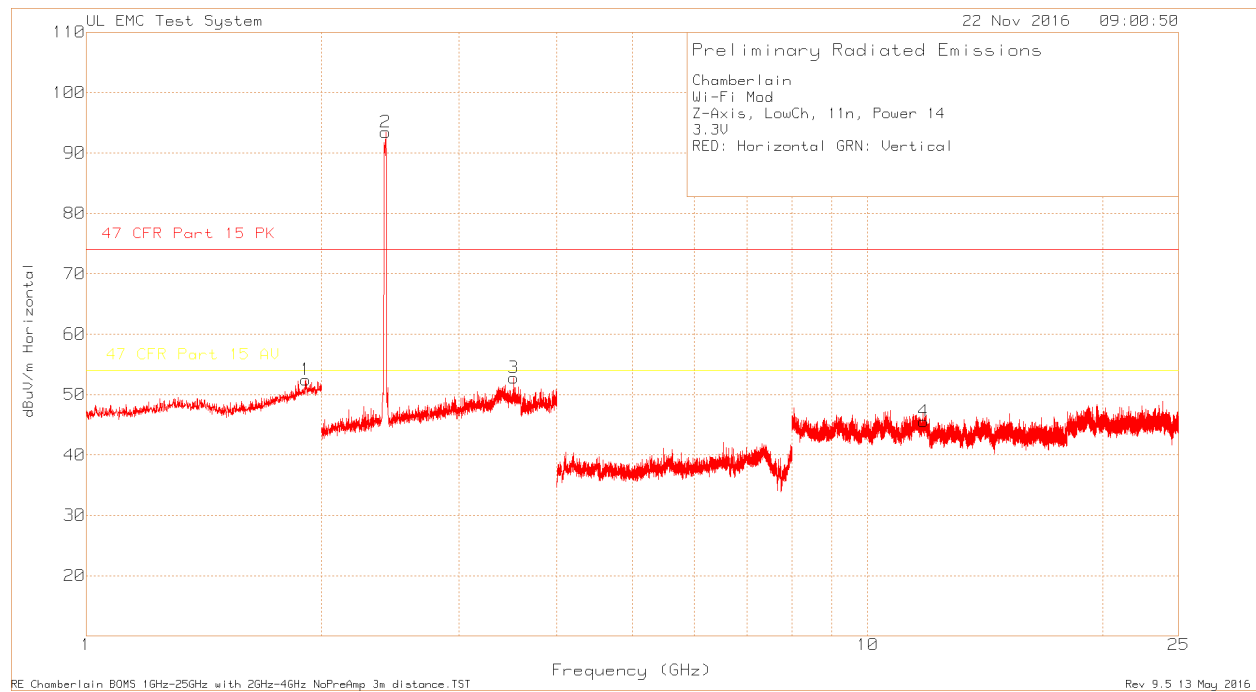
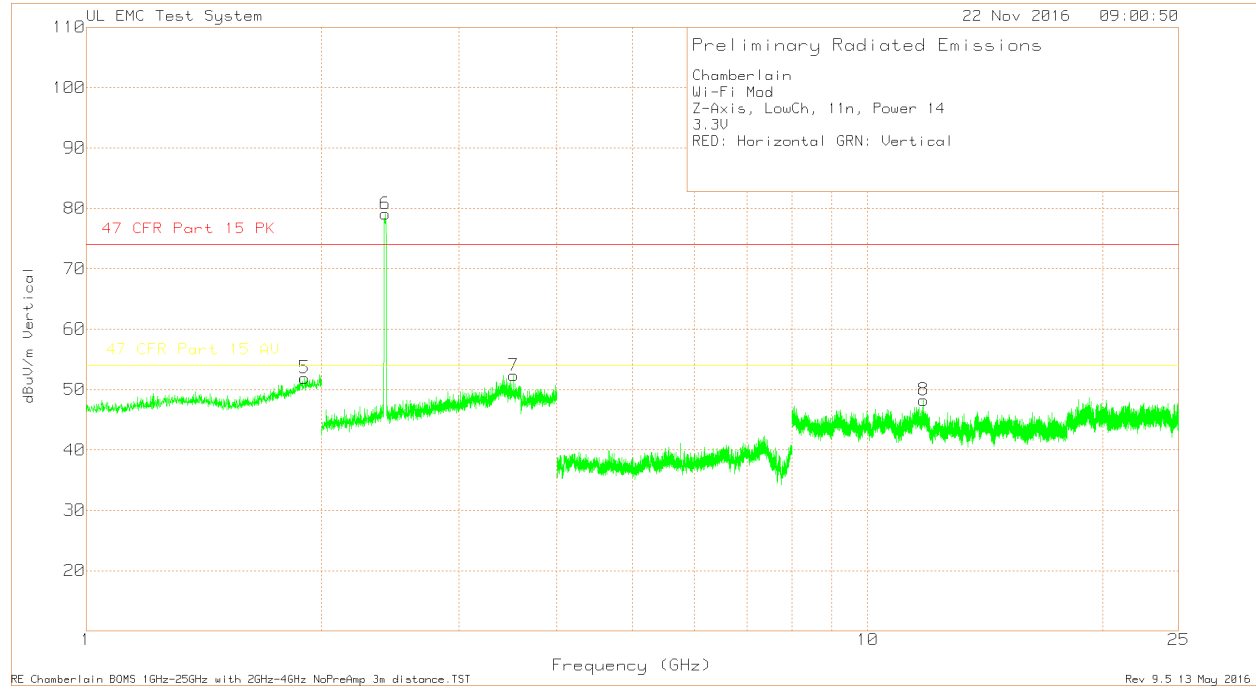

Low Channel Data

Chamberlain

Wi-Fi Mod

Z-Axis, LowCh, 11n, Power 14

3.3V

RED: Horizontal GRN: Vertical

Trace Markers

Test No.	Frequency (GHz)	Meter Reading	Transducer Factor (dB)	Gain/Loss Factor (dB)	Corrected Reading	Limit:1	Limit:2
1	1.908	65.84dBuV Pk	31.2	-44.64	52.4	74	54
		Azimuth:0-360	Height:148	Horz	Margin (dB)	-21.6	-1.6
2	2.416	66.98dBuV Pk	21.8	4.65	93.43	-	-
		Azimuth:0-360	Height:148	Horz	Margin (dB)	-	-
3	3.526	23.65dBuV Pk	23.4	5.72	52.77	74	54
		Azimuth:0-360	Height:148	Horz	Margin (dB)	-21.23	-1.23
4	11.785	54.25dBuV Pk	37.8	-46.55	45.5	74	54
		Azimuth:0-360	Height:148	Horz	Margin (dB)	-28.5	-8.5
5	1.903	65.4dBuV Pk	31.2	-44.68	51.92	74	54
		Azimuth:0-360	Height:148	Vert	Margin (dB)	-22.08	-2.08
6	2.413	52.63dBuV Pk	21.8	4.65	79.08	-	-
		Azimuth:0-360	Height:148	Vert	Margin (dB)	-	-
7	3.521	23.23dBuV Pk	23.4	5.66	52.29	74	54
		Azimuth:0-360	Height:148	Vert	Margin (dB)	-21.71	-1.71
8	11.785	57.02dBuV Pk	37.8	-46.55	48.27	74	54
		Azimuth:0-360	Height:148	Vert	Margin (dB)	-25.73	-5.73

LIMIT 1: 47 CFR Part 15 PK

LIMIT 2: 47 CFR Part 15 AV

Pk - Peak detector

Middle Channel Plot

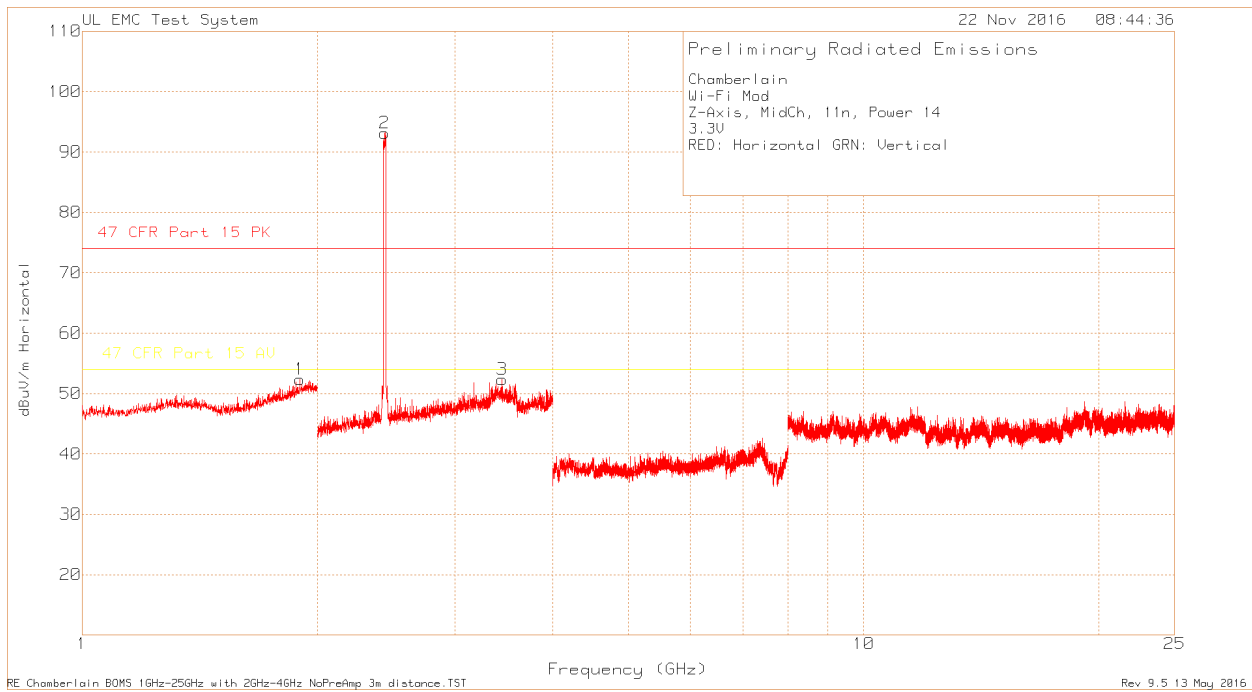
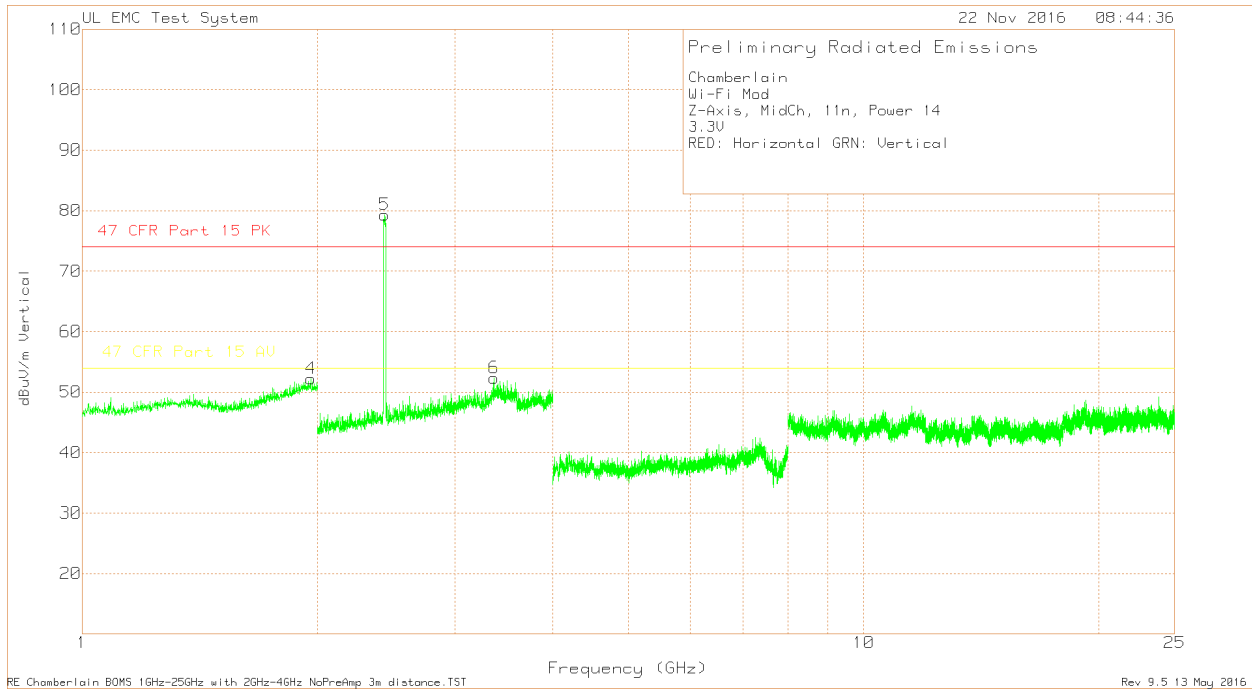

Middle Channel Data

Chamberlain

Wi-Fi Mod

Z-Axis, MidCh, 11n, Power 14

3.3V

RED: Horizontal GRN: Vertical

Trace Markers

No.	Test Frequency (GHz)	Meter Reading	Transducer Factor (dB)	Gain/Loss Factor (dB)	Corrected Reading dBuV/m	Limit:1	2
1	1.898	65.84dBuV Pk	31.2	-44.71	52.33	74	54
		Azimuth:0-360	Height:148	Horz	Margin (dB)	-21.67	-1.67
2	2.436	66.47dBuV Pk	21.9	4.72	93.09	-	-
		Azimuth:0-360	Height:148	Horz	Margin (dB)	-	-
3	3.446	23dBuV Pk	23.5	5.83	52.33	74	54
		Azimuth:0-360	Height:148	Horz	Margin (dB)	-21.67	-1.67
4	1.961	65.18dBuV Pk	31.5	-44.5	52.18	74	54
		Azimuth:0-360	Height:148	Vert	Margin (dB)	-21.82	-1.82
5	2.437	52.67dBuV Pk	21.9	4.72	79.29	-	-
		Azimuth:0-360	Height:148	Vert	Margin (dB)	-	-
6	3.363	23.36dBuV Pk	23.2	5.74	52.3	74	54
		Azimuth:0-360	Height:148	Vert	Margin (dB)	-21.7	-1.7

LIMIT 1: 47 CFR Part 15 PK

LIMIT 2: 47 CFR Part 15 AV

Pk - Peak detector

High Channel Plot

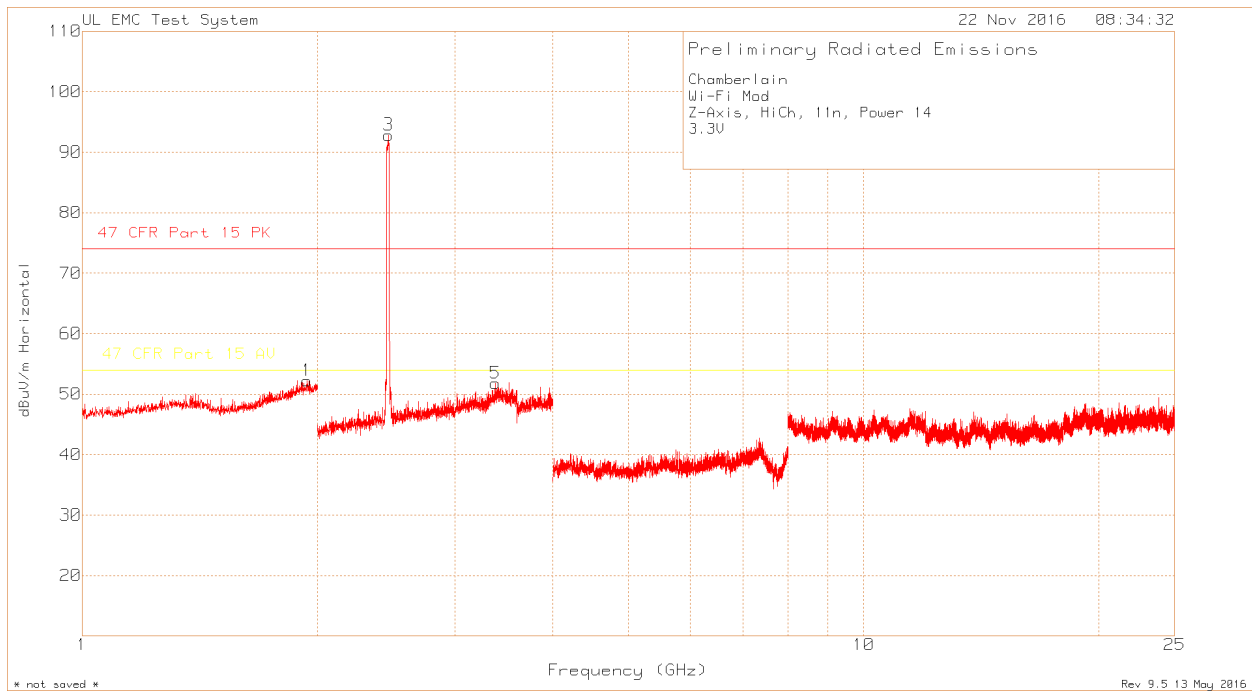
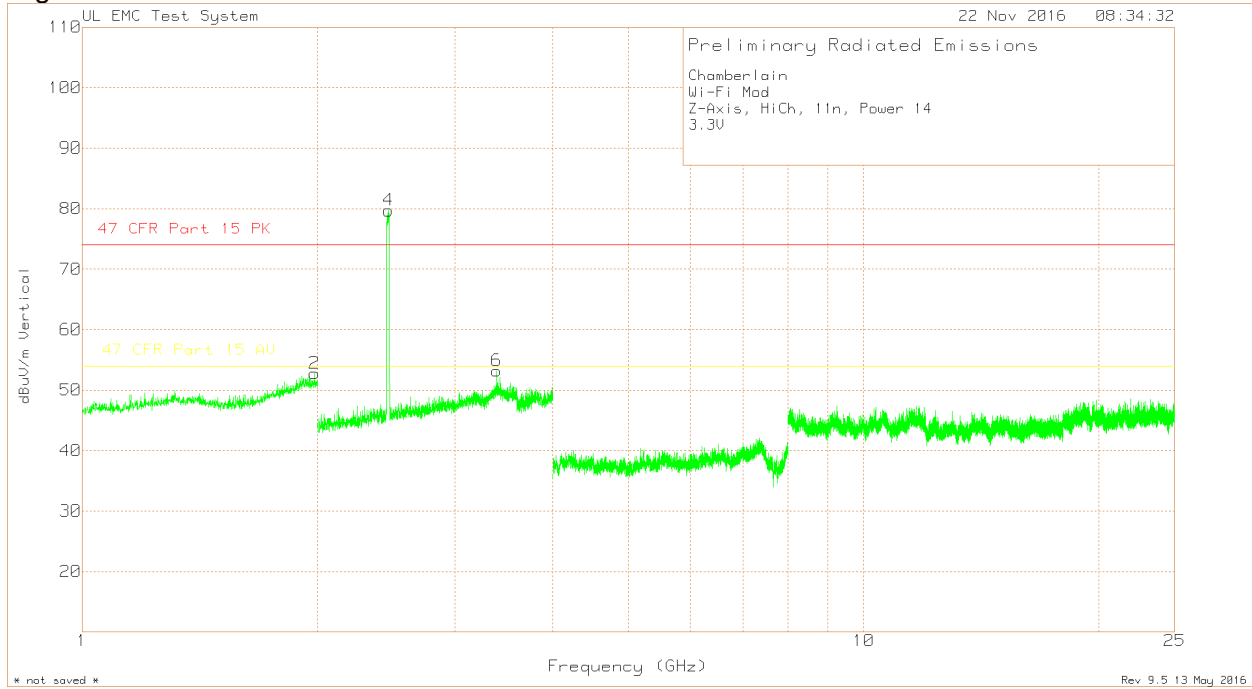

High Channel Data

Chamberlain
 Wi-Fi Mod
 Z-Axis, HiCh, 11n, Power 14
 3.3V

Trace Markers

Test No.	Frequency (GHz)	Meter Reading	Transducer Factor (dB)	Gain/Loss Factor (dB)	Corrected Reading	Limit:1	2
					dBuV/m		
1	1.94	65.33dBuV Pk	31.4	-44.52	52.21	74	54
		Azimuth:0-360	Height:148	Horz	Margin (dB)	-21.79	-1.79
3	2.464	66.11dBuV Pk	22	4.72	92.83	-	-
		Azimuth:0-360	Height:148	Horz	Margin (dB)	-	-
5	3.379	22.67dBuV Pk	23.3	5.83	51.8	74	54
		Azimuth:0-360	Height:148	Horz	Margin (dB)	-22.2	-2.2
2	1.982	65.48dBuV Pk	31.7	-44.42	52.76	74	54
		Azimuth:0-360	Height:148	Vert	Margin (dB)	-21.24	-1.24
4	2.466	52.98dBuV Pk	22	4.72	79.7	-	-
		Azimuth:0-360	Height:148	Vert	Margin (dB)	-	-
6	3.392	24.03dBuV Pk	23.4	5.77	53.2	74	54
		Azimuth:0-360	Height:148	Vert	Margin (dB)	-20.8	-.8

LIMIT 1: 47 CFR Part 15 PK
 LIMIT 2: 47 CFR Part 15 AV

Pk - Peak detector

9.3. RADIATED BELOW 1 GHz

9.3.1. SPURIOUS EMISSIONS 9kHz TO 30 MHz 802.11b

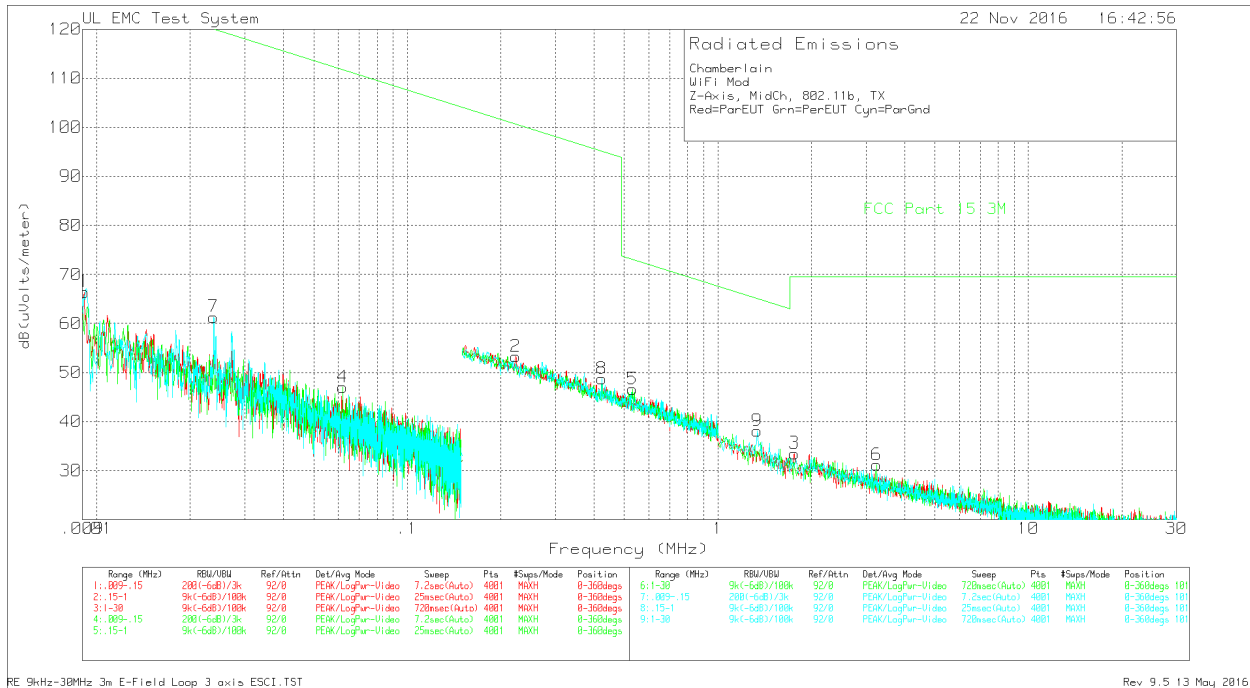

Chamberlain
 WiFi Mod
 Z-Axis, MidCh, 802.11b, TX
 Red=ParEUT Grn=PerEUT Cyn=ParGnd

Trace Markers

Test No.	Frequency (MHz)	Meter Reading	Transducer Factor (dB)	Gain/Loss Factor (dB)	Corrected Reading	Limit:1 Reading
Parallel to EUT						
1	.00911	44.08dBuV Pk	22.3	0	66.38	128.4
		Azimuth:0-360	Height:101	Horz	Margin (dB)	-62.02
2	.22391	41.94dBuV Pk	11.3	0	53.24	100.6
		Azimuth:0-360	Height:101	Horz	Margin (dB)	-47.36
3	1.7685	21.89dBuV Pk	11.5	.1	33.49	69.54
		Azimuth:0-360	Height:101	Horz	Margin (dB)	-36.05
Perpend to EUT						
4	.06203	34.8dBuV Pk	12.2	0	47	111.74
		Azimuth:0-360	Height:101	Horz	Margin (dB)	-64.74
5	.53127	35.32dBuV Pk	11.3	0	46.62	73.1
		Azimuth:0-360	Height:101	Horz	Margin (dB)	-26.48
6	3.25475	19.57dBuV Pk	11.5	.1	31.17	69.54
		Azimuth:0-360	Height:101	Horz	Margin (dB)	-38.37
Parallel to GND						
7	.02381	45.41dBuV Pk	15.9	0	61.31	120.06
		Azimuth:0-360	Height:101	Horz	Margin (dB)	-58.75
8	.42349	37.46dBuV Pk	11.3	0	48.76	95.07
		Azimuth:0-360	Height:101	Horz	Margin (dB)	-46.31
9	1.34075	26.55dBuV Pk	11.4	.1	38.05	65.06
		Azimuth:0-360	Height:101	Horz	Margin (dB)	-27.01

LIMIT 1: FCC Part 15 3M
 Pk - Peak detector

9.3.2. SPURIOUS EMISSIONS 9kHz TO 30 MHz 802.11g

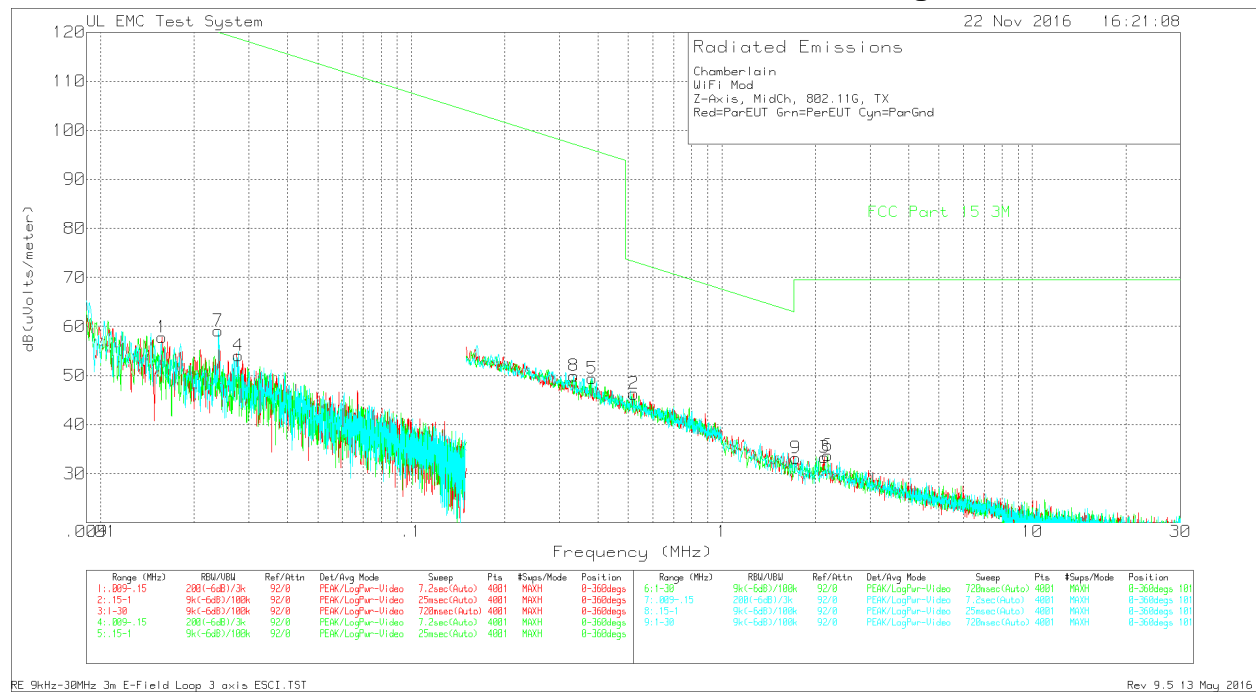

Chamberlain
 WiFi Mod
 Z-Axis, MidCh, 802.11G, TX
 Red=ParEUT Grn=PerEUT Cyn=ParGnd

Trace Markers

Test No.	Frequency (MHz)	Meter Reading	Transducer Factor (dB)	Gain/Loss Factor (dB)	Corrected Reading dB (uVolts/meter)	Limit:1 Reading dB (uVolts/meter)
=====						
Parallel to EUT						
1	.01576	39.17dBuV Pk	18.6	0	57.77	123.64
		Azimuth:0-360	Height:101	Horz	Margin (dB)	-65.87
2	.52041	34.99dBuV Pk	11.3	0	46.29	73.28
		Azimuth:0-360	Height:101	Horz	Margin (dB)	-26.99
3	2.13825	21.7dBuV Pk	11.5	.1	33.3	69.54
		Azimuth:0-360	Height:101	Horz	Margin (dB)	-36.24
Perpend to EUT						
4	.02776	38.62dBuV Pk	15.4	0	54.02	118.72
		Azimuth:0-360	Height:101	Horz	Margin (dB)	-64.7
5	.38249	38.11dBuV Pk	11.3	0	49.41	95.95
		Azimuth:0-360	Height:101	Horz	Margin (dB)	-46.54
6	2.19625	22.08dBuV Pk	11.5	.1	33.68	69.54
		Azimuth:0-360	Height:101	Horz	Margin (dB)	-35.86
Parallel to GND						
7	.02395	43.22dBuV Pk	15.9	0	59.12	120.01
		Azimuth:0-360	Height:101	Horz	Margin (dB)	-60.89
8	.33361	38.61dBuV Pk	11.3	0	49.91	97.14
		Azimuth:0-360	Height:101	Horz	Margin (dB)	-47.23
9	1.73225	21.52dBuV Pk	11.5	.1	33.12	69.54
		Azimuth:0-360	Height:101	Horz	Margin (dB)	-36.42
LIMIT 1: FCC Part 15 3M						
Pk - Peak detector						

9.3.3. SPURIOUS EMISSIONS 9kHz TO 30 MHz 802.11n

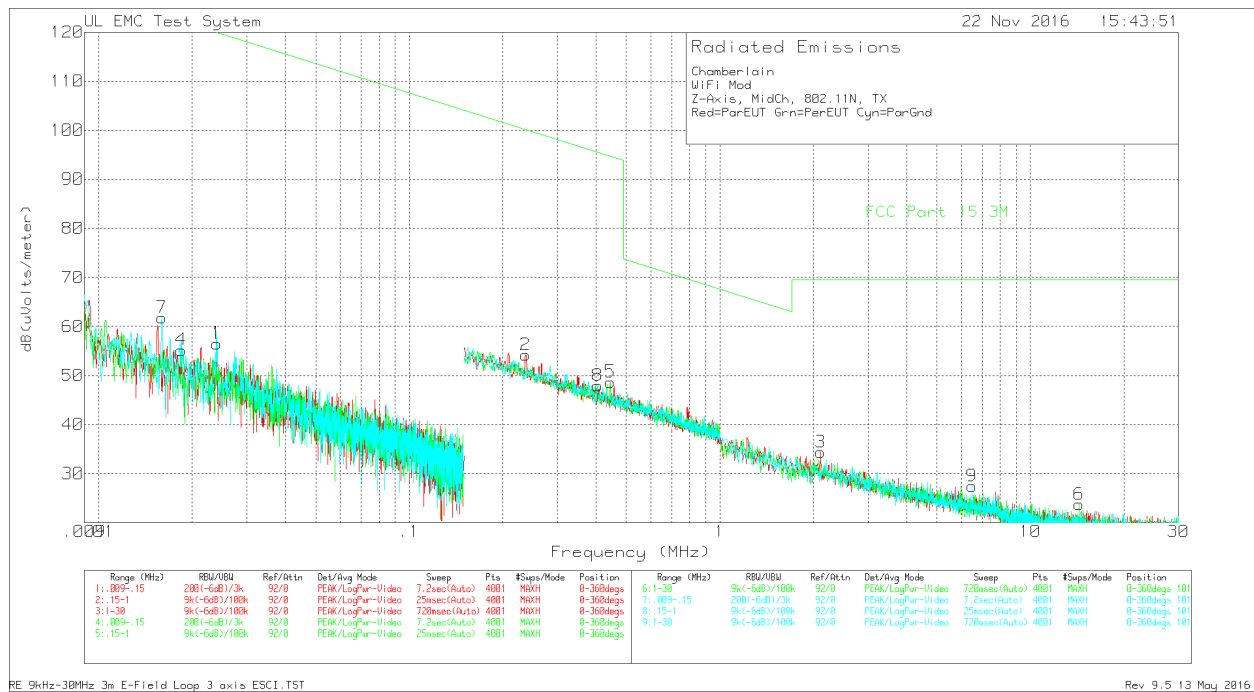

Chamberlain
 WiFi Mod
 Z-Axis, MidCh, 802.11N, TX
 Red=ParEUT Grn=PerEUT Cyn=ParGnd

Trace Markers

Test No.	Frequency (MHz)	Meter Reading	Transducer Factor (dB)	Gain/Loss Factor (dB)	Corrected Reading dB(uVolts/meter)	Limit:1
=====						
Parallel to EUT						
1	.02398	40.61dBuV Pk	15.9	0	56.51	119.99
		Azimuth:0-360	Height:101	Horz	Margin (dB)	-63.48
2	.23722	42.89dBuV Pk	11.3	0	54.19	100.1
		Azimuth:0-360	Height:101	Horz	Margin (dB)	-45.91
3	2.10925	22.76dBuV Pk	11.5	.1	34.36	69.54
		Azimuth:0-360	Height:101	Horz	Margin (dB)	-35.18
Perpend to EUT						
4	.01845	37.99dBuV Pk	17.2	0	55.19	122.27
		Azimuth:0-360	Height:101	Horz	Margin (dB)	-67.08
5	.44394	37.35dBuV Pk	11.3	0	48.65	94.66
		Azimuth:0-360	Height:101	Horz	Margin (dB)	-46.01
6	14.3545	13.43dBuV Pk	10.1	.2	23.73	69.54
		Azimuth:0-360	Height:101	Horz	Margin (dB)	-45.81
Parallel to GND						
7	.01597	43.28dBuV Pk	18.5	0	61.78	123.52
		Azimuth:0-360	Height:101	Horz	Margin (dB)	-61.74
8	.40454	36.6dBuV Pk	11.3	0	47.9	95.46
		Azimuth:0-360	Height:101	Horz	Margin (dB)	-47.56
9	6.481	16.16dBuV Pk	11.2	.1	27.46	69.54
		Azimuth:0-360	Height:101	Horz	Margin (dB)	-42.08

LIMIT 1: FCC Part 15 3M
 Pk - Peak detector

9.3.4. SPURIOUS EMISSIONS 9kHz TO 30 MHz Open Field Correlation Data

Correlation Data for measurements 9kHz-30MHz between Outside and 10m semi-anechoic chamber in at Underwriter Laboratories in Northbrook, IL.

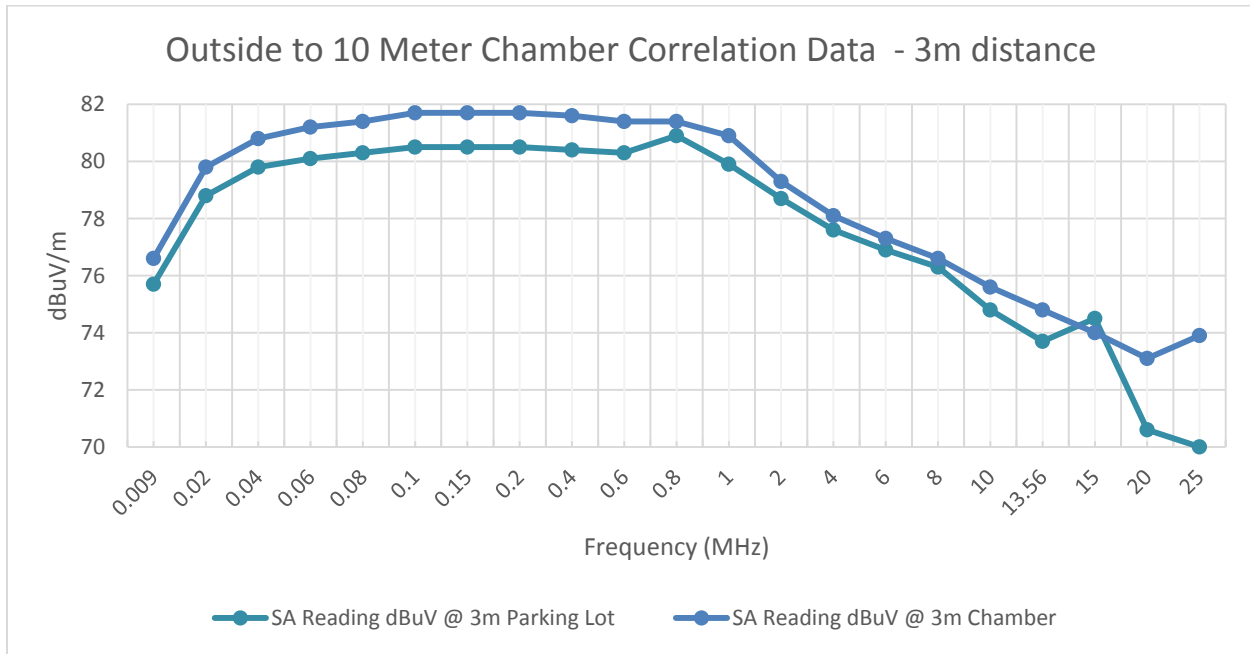

Correlation measurements were conducted using a signal source with an antenna outside in open area (parking lot). Immediately following the measurements the same setup was moved inside the 10 meter semi-anechoic chamber and the measurements were repeated. The above plot shows the difference in levels measured between outside and the 10 meter semi anechoic chamber.

9.3.6. SPURIOUS EMISSIONS 30 TO 1000 MHz for 802.11b

Low Channel Plots

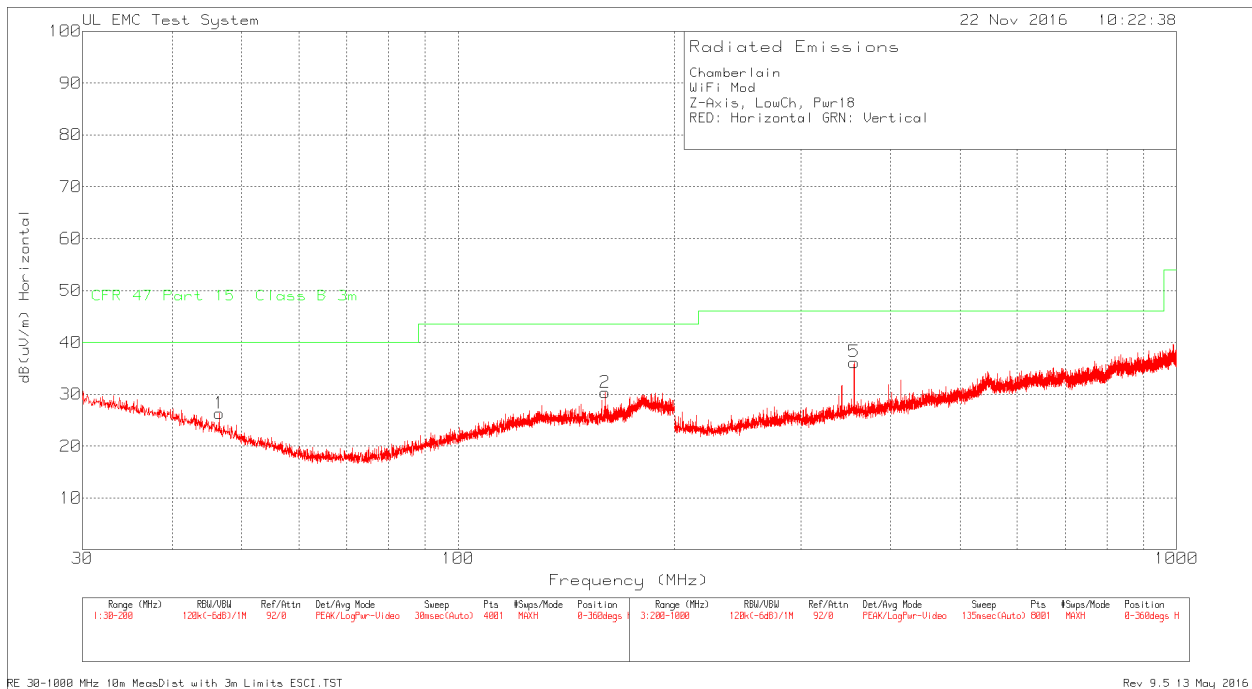
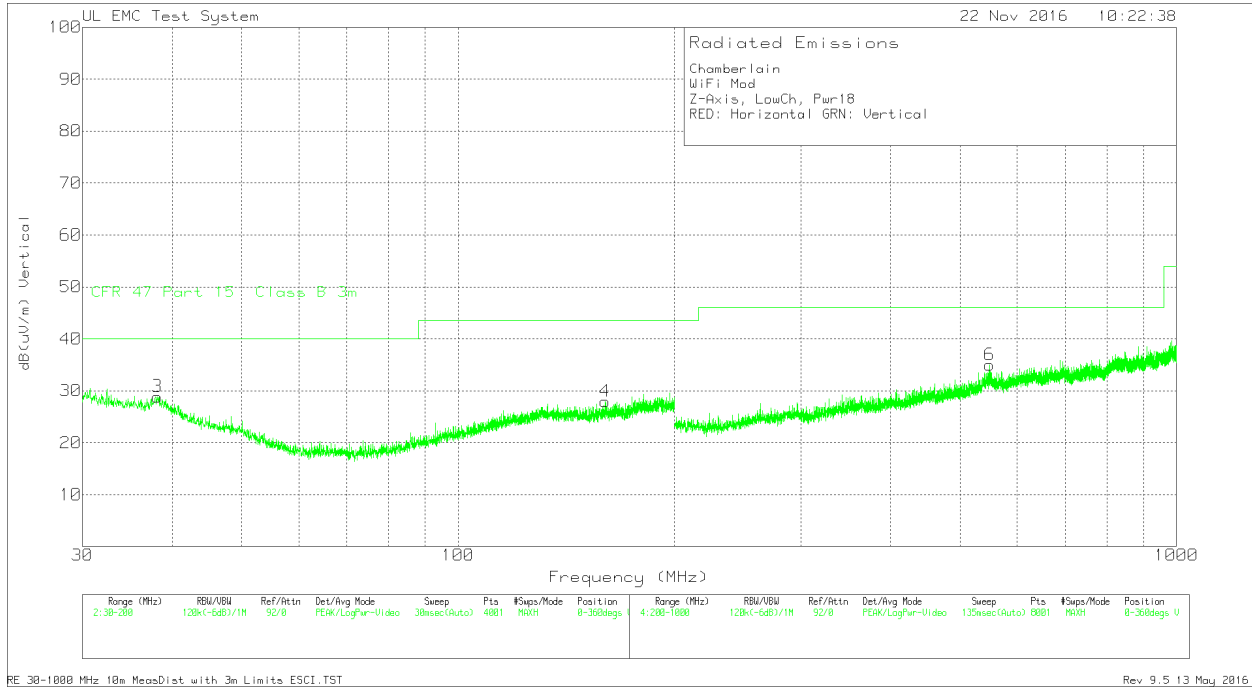

Low Channel Data

Chamberlain

WiFi Mod

Z-Axis, LowCh, Pwr18

RED: Horizontal GRN: Vertical

Trace Markers

No.	Test Frequency (MHz)	Meter Reading	Transducer Factor (dB)	Gain/Loss Factor (dB)	Corrected Reading dB (uV/m)	Limit:1
1	46.49	34.02dBuV Pk	11.8	-19.5	26.32	40
		Azimuth:0-360	Height:249	Horz	Margin (dB)	-13.68
2	160.0925	34.45dBuV Pk	14.9	-19	30.35	43.52
		Azimuth:0-360	Height:399	Horz	Margin (dB)	-13.17
3	38.16	33.36dBuV Pk	15	-19.5	28.86	40
		Azimuth:0-360	Height:102	Vert	Margin (dB)	-11.14
4	160.0925	32.02dBuV Pk	14.9	-19	27.92	43.52
		Azimuth:0-360	Height:399	Vert	Margin (dB)	-15.6
5	355.9	38.98dBuV Pk	15.2	-18	36.18	46.02
		Azimuth:0-360	Height:199	Horz	Margin (dB)	-9.84
6	549.3	32.14dBuV Pk	19.9	-17.1	34.94	46.02
		Azimuth:0-360	Height:399	Vert	Margin (dB)	-11.08

LIMIT 1: CFR 47 Part 15 Class B 3m

Pk - Peak detector

Middle Channel Plots

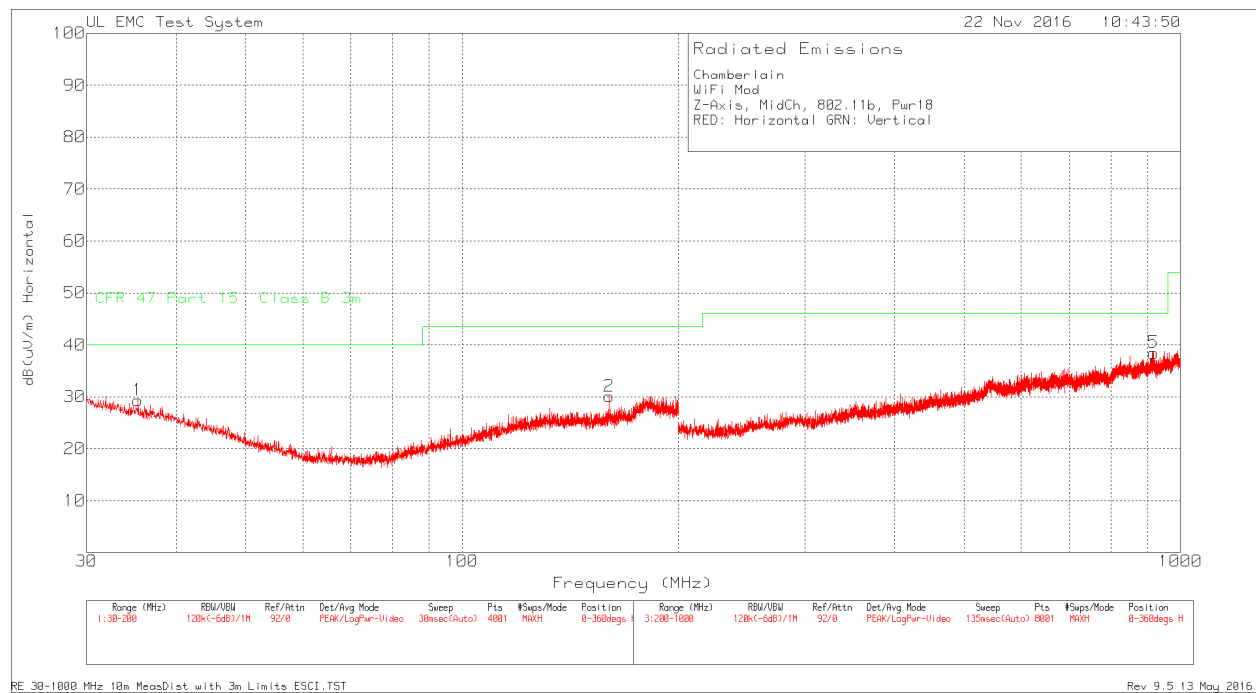
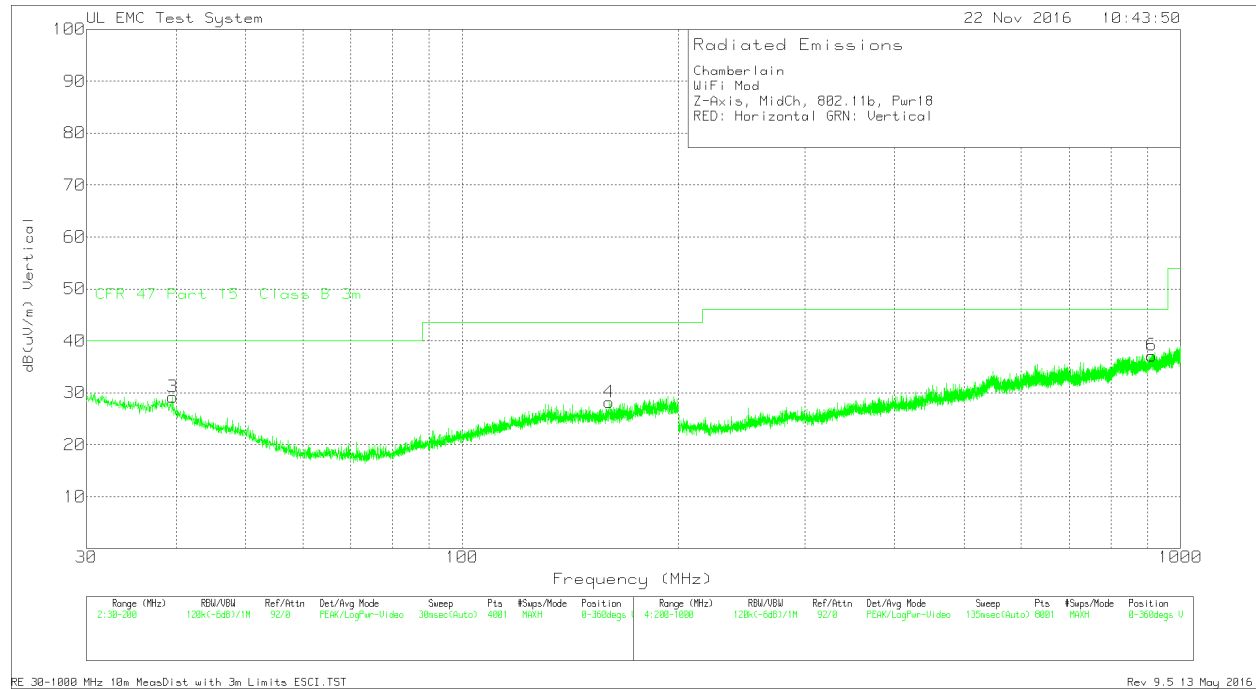

Middle Channel Data

Chamberlain
 WiFi Mod
 Z-Axis, MidCh, 802.11b, Pwr18
 RED: Horizontal GRN: Vertical

Trace Markers

No.	Test Frequency (MHz)	Meter Reading	Transducer Factor (dB)	Gain/Loss Factor (dB)	Corrected Reading dB (uV/m)	Limit:1
1	35.3975	32.59dBuV Pk	16.1	-19.4	29.29	40
		Azimuth:0-360	Height:399	Horz	Margin (dB)	-10.71
2	160.0925	34.19dBuV Pk	14.9	-19	30.09	43.52
		Azimuth:0-360	Height:399	Horz	Margin (dB)	-13.43
3	39.5625	34.22dBuV Pk	14.5	-19.5	29.22	40
		Azimuth:0-360	Height:251	Vert	Margin (dB)	-10.78
4	160.0925	32.3dBuV Pk	14.9	-19	28.2	43.52
		Azimuth:0-360	Height:101	Vert	Margin (dB)	-15.32
5	917.3	32.55dBuV Pk	23.3	-17.4	38.45	46.02
		Azimuth:0-360	Height:98	Horz	Margin (dB)	-7.57
6	911.7	30.98dBuV Pk	23.3	-17.1	37.18	46.02
		Azimuth:0-360	Height:99	Vert	Margin (dB)	-8.84

LIMIT 1: CFR 47 Part 15 Class B 3m
 Pk - Peak detector

High Channel Plots

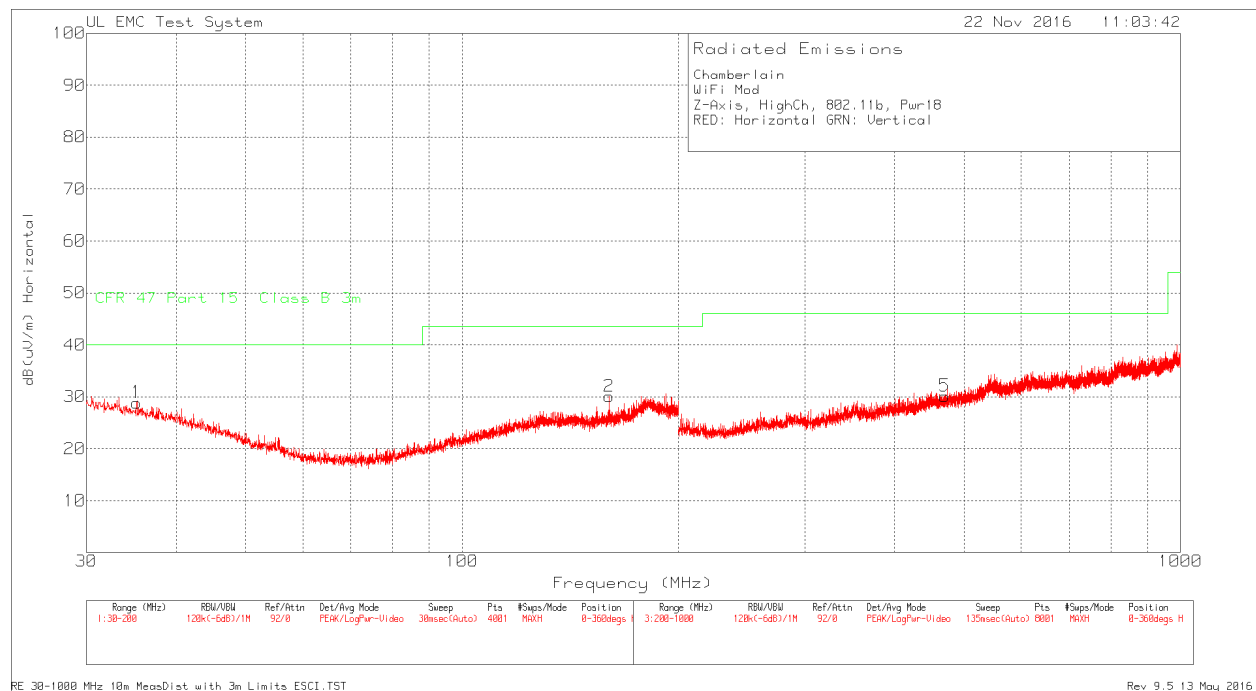
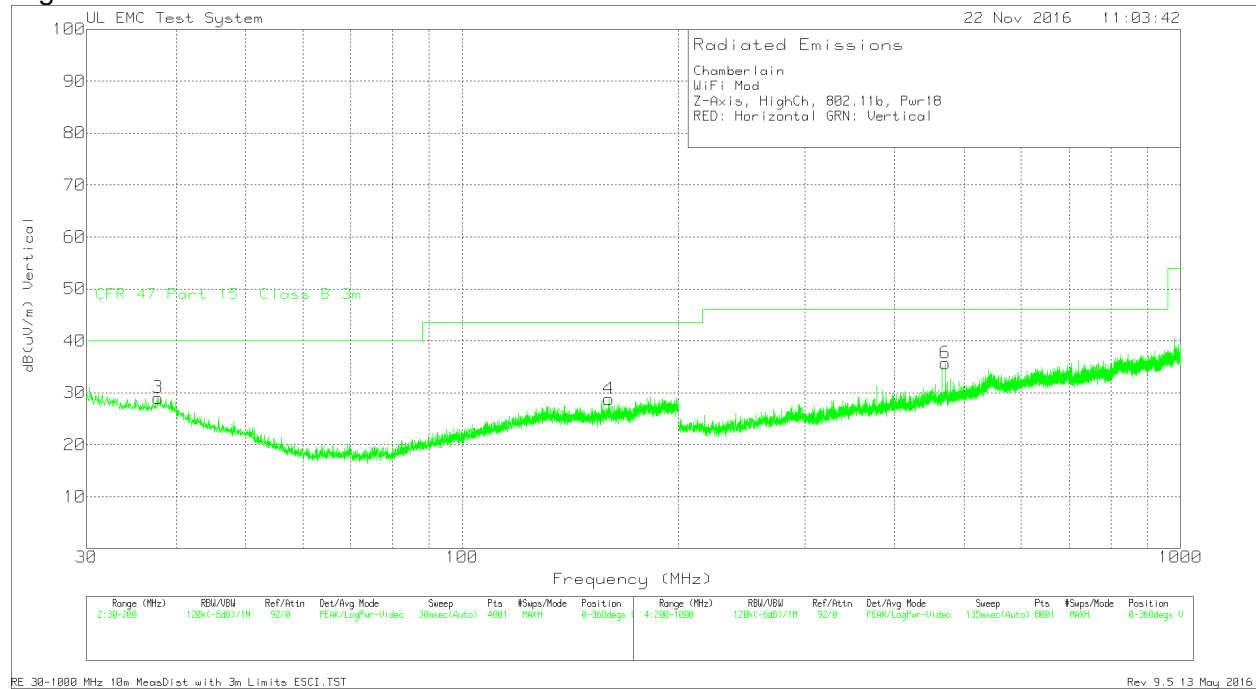

High Channel Data

Chamberlain
 WiFi Mod
 Z-Axis, HighCh, 802.11b, Pwr18
 RED: Horizontal GRN: Vertical

Trace Markers

No.	Test Frequency (MHz)	Meter Reading	Transducer Factor (dB)	Gain/Loss Factor (dB)	Corrected Reading (uV/m)	Limit:1 (dB)
1	35.2275	32.17dBuV Pk	16.1	-19.4	28.87	40
		Azimuth:0-360	Height:101	Horz	Margin (dB)	-11.13
2	160.0925	34.14dBuV Pk	14.9	-19	30.04	43.52
		Azimuth:0-360	Height:398	Horz	Margin (dB)	-13.48
3	37.7775	33.32dBuV Pk	15.2	-19.5	29.02	40
		Azimuth:0-360	Height:101	Vert	Margin (dB)	-10.98
4	160.05	32.88dBuV Pk	14.9	-19	28.78	43.52
		Azimuth:0-360	Height:398	Vert	Margin (dB)	-14.74
5	469.8	30.53dBuV Pk	17.2	-17.6	30.13	46.02
		Azimuth:0-360	Height:399	Horz	Margin (dB)	-15.89
6	470.2	36.08dBuV Pk	17.2	-17.6	35.68	46.02
		Azimuth:0-360	Height:99	Vert	Margin (dB)	-10.34

LIMIT 1: CFR 47 Part 15 Class B 3m
 Pk - Peak detector

9.3.7. SPURIOUS EMISSIONS 30 TO 1000 MHz for 802.11g

Low Channel Plots

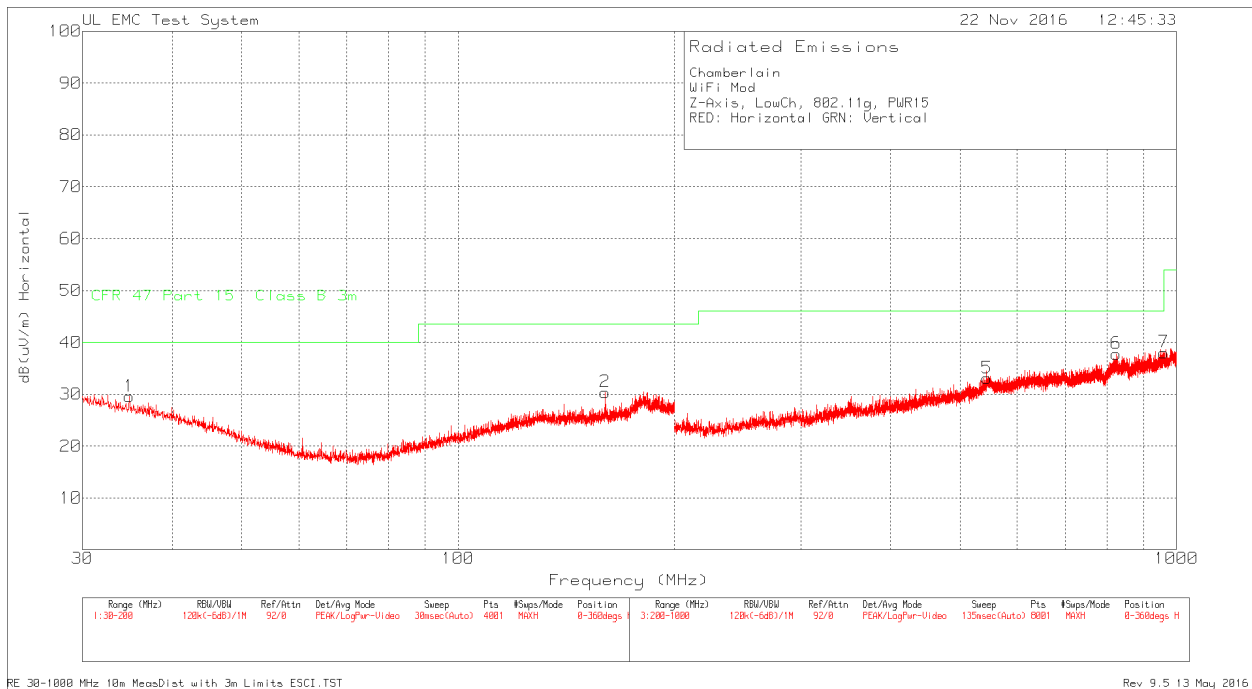
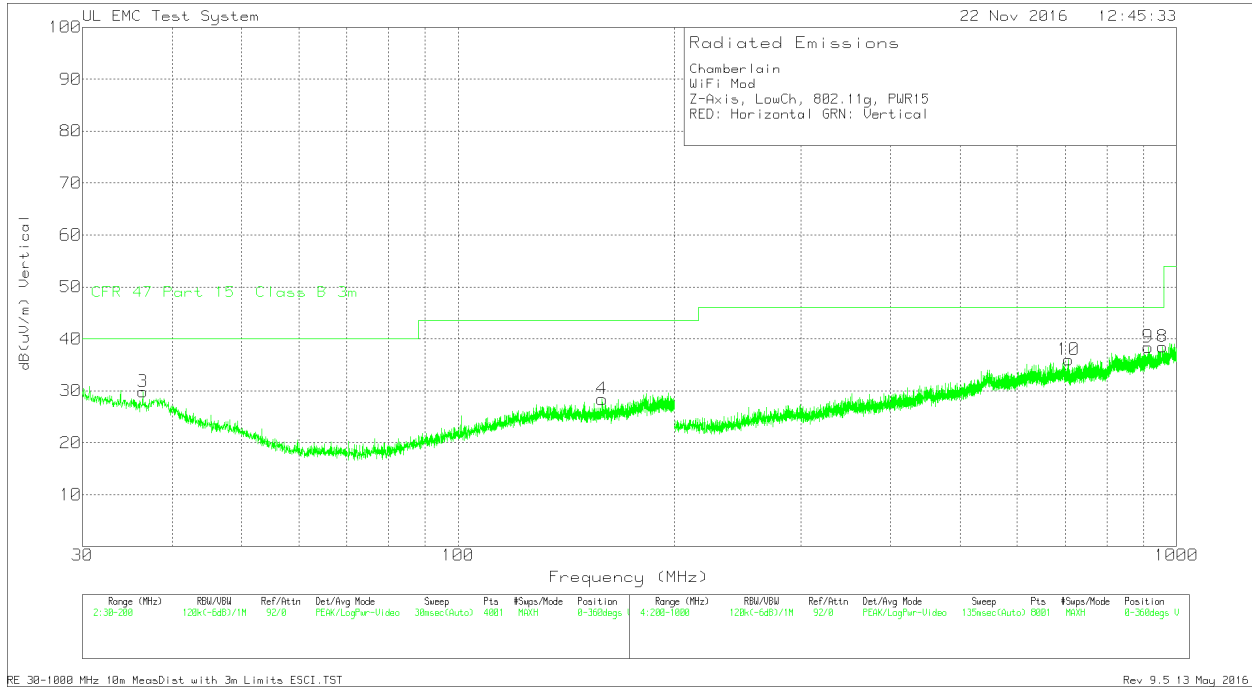

Low Channel Data

Chamberlain

WiFi Mod

Z-Axis, LowCh, 802.11g, PWR15

RED: Horizontal GRN: Vertical

Trace Markers

No.	Test Frequency (MHz)	Meter Reading	Transducer Factor (dB)	Gain/Loss Factor (dB)	Corrected Reading dB (uV/m)	Limit:1
1	34.845	32.81dBuV Pk	16.3	-19.5	29.61	40
		Azimuth:0-360	Height:398	Horz	Margin (dB)	-10.39
2	160.0925	34.5dBuV Pk	14.9	-19	30.4	43.52
		Azimuth:0-360	Height:398	Horz	Margin (dB)	-13.12
3	36.4175	33.52dBuV Pk	15.7	-19.4	29.82	40
		Azimuth:0-360	Height:252	Vert	Margin (dB)	-10.18
4	158.69	32.6dBuV Pk	14.8	-19	28.4	43.52
		Azimuth:0-360	Height:101	Vert	Margin (dB)	-15.12
5	545.1	30.17dBuV Pk	20.1	-17.2	33.07	46.02
		Azimuth:0-360	Height:199	Horz	Margin (dB)	-12.95
6	823.9	32.31dBuV Pk	22.7	-17.2	37.81	46.02
		Azimuth:0-360	Height:299	Horz	Margin (dB)	-8.21
7	960.3	31.36dBuV Pk	23.6	-16.9	38.06	53.97
		Azimuth:0-360	Height:199	Horz	Margin (dB)	-15.91
8	956	31.69dBuV Pk	23.5	-16.7	38.49	46.02
		Azimuth:0-360	Height:399	Vert	Margin (dB)	-7.53
9	912.6	32.21dBuV Pk	23.3	-17.1	38.41	46.02
		Azimuth:0-360	Height:302	Vert	Margin (dB)	-7.61
10	707.9	32.51dBuV Pk	20.2	-16.7	36.01	46.02
		Azimuth:0-360	Height:99	Vert	Margin (dB)	-10.01

LIMIT 1: CFR 47 Part 15 Class B 3m

Pk - Peak detector

Middle Channel Plots

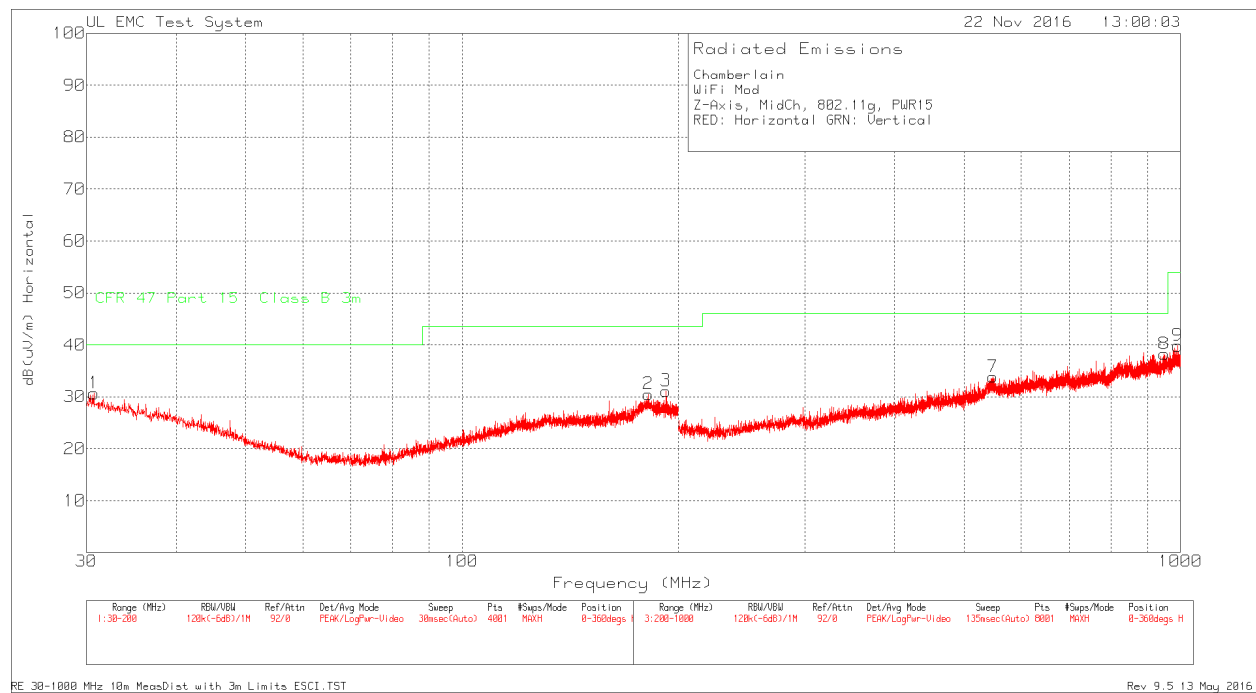
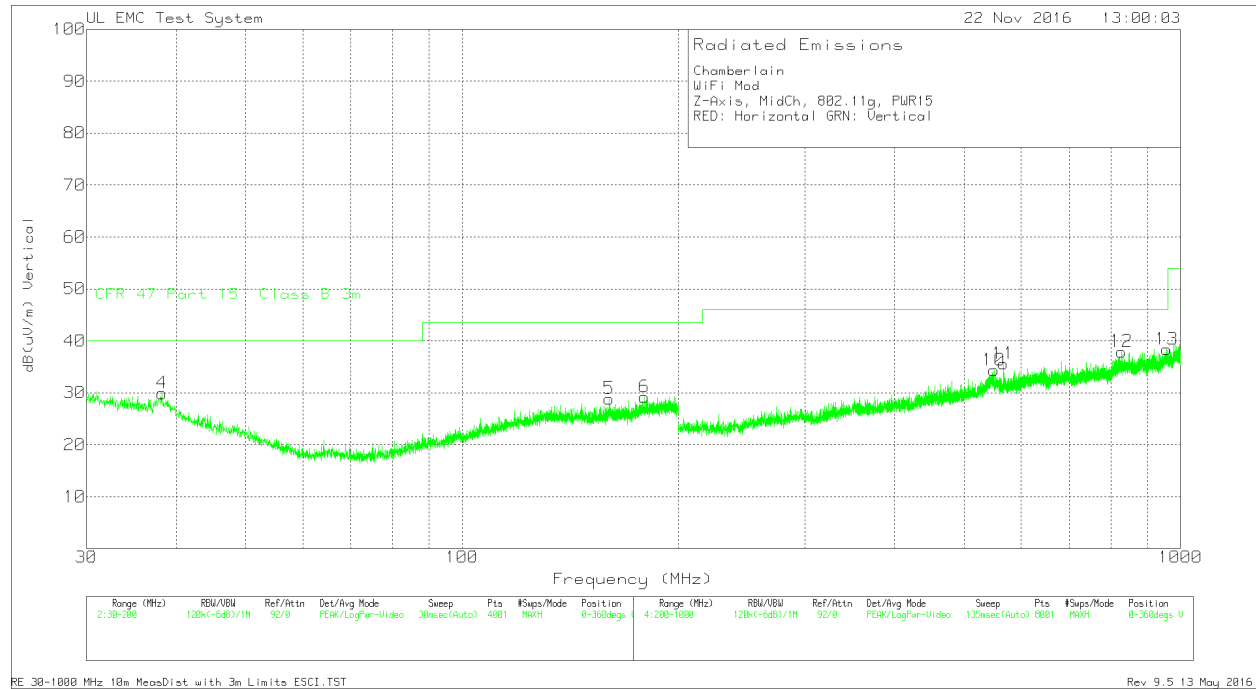

Middle Channel Data

Chamberlain
 WiFi Mod
 Z-Axis, LowCh, 802.11g, PWR15
 RED: Horizontal GRN: Vertical

Trace Markers

Test No.	Frequency (MHz)	Meter Reading	Transducer Factor (dB)	Gain/Loss Factor (dB)	Corrected Reading (uV/m)	Limit:1 (dB)
1	34.845	32.81dBuV Pk	16.3	-19.5	29.61	40
		Azimuth:0-360	Height:398	Horz	Margin (dB)	-10.39
2	160.0925	34.5dBuV Pk	14.9	-19	30.4	43.52
		Azimuth:0-360	Height:398	Horz	Margin (dB)	-13.12
3	36.4175	33.52dBuV Pk	15.7	-19.4	29.82	40
		Azimuth:0-360	Height:252	Vert	Margin (dB)	-10.18
4	158.69	32.6dBuV Pk	14.8	-19	28.4	43.52
		Azimuth:0-360	Height:101	Vert	Margin (dB)	-15.12
5	545.1	30.17dBuV Pk	20.1	-17.2	33.07	46.02
		Azimuth:0-360	Height:199	Horz	Margin (dB)	-12.95
6	823.9	32.31dBuV Pk	22.7	-17.2	37.81	46.02
		Azimuth:0-360	Height:299	Horz	Margin (dB)	-8.21
7	960.3	31.36dBuV Pk	23.6	-16.9	38.06	53.97
		Azimuth:0-360	Height:199	Horz	Margin (dB)	-15.91
8	956	31.69dBuV Pk	23.5	-16.7	38.49	46.02
		Azimuth:0-360	Height:399	Vert	Margin (dB)	-7.53
9	912.6	32.21dBuV Pk	23.3	-17.1	38.41	46.02
		Azimuth:0-360	Height:302	Vert	Margin (dB)	-7.61
10	707.9	32.51dBuV Pk	20.2	-16.7	36.01	46.02
		Azimuth:0-360	Height:99	Vert	Margin (dB)	-10.01

LIMIT 1: CFR 47 Part 15 Class B 3m
 Pk - Peak detector

High Channel Plots

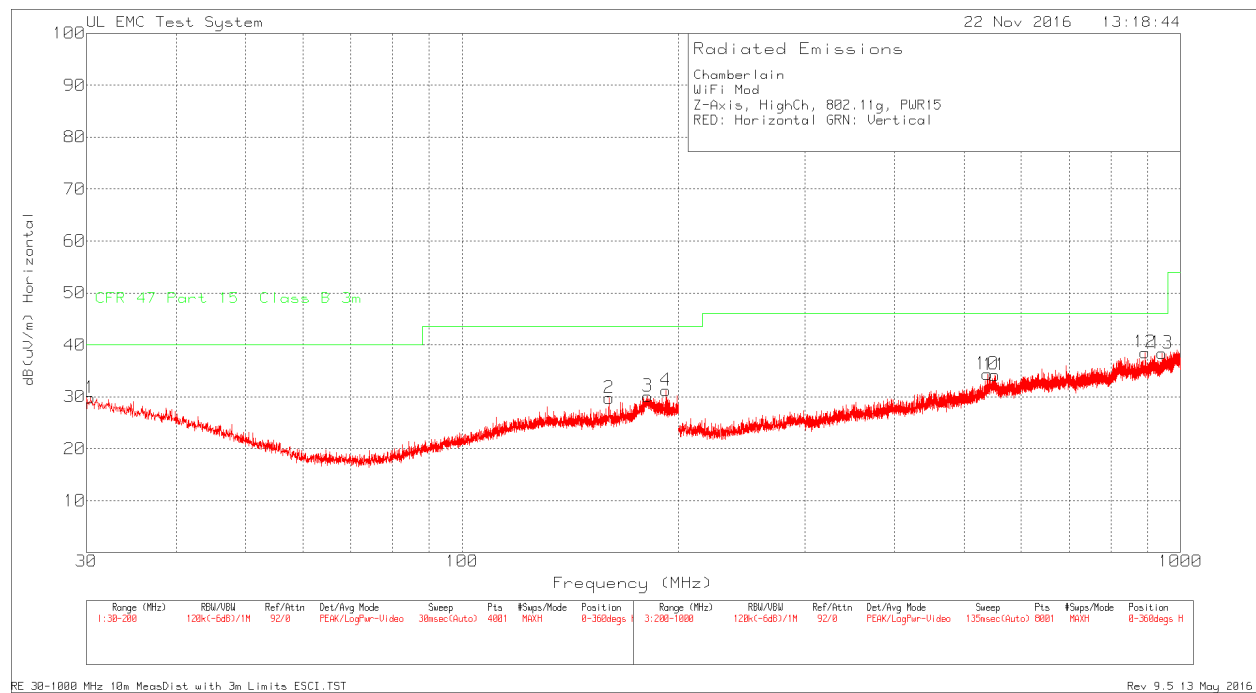
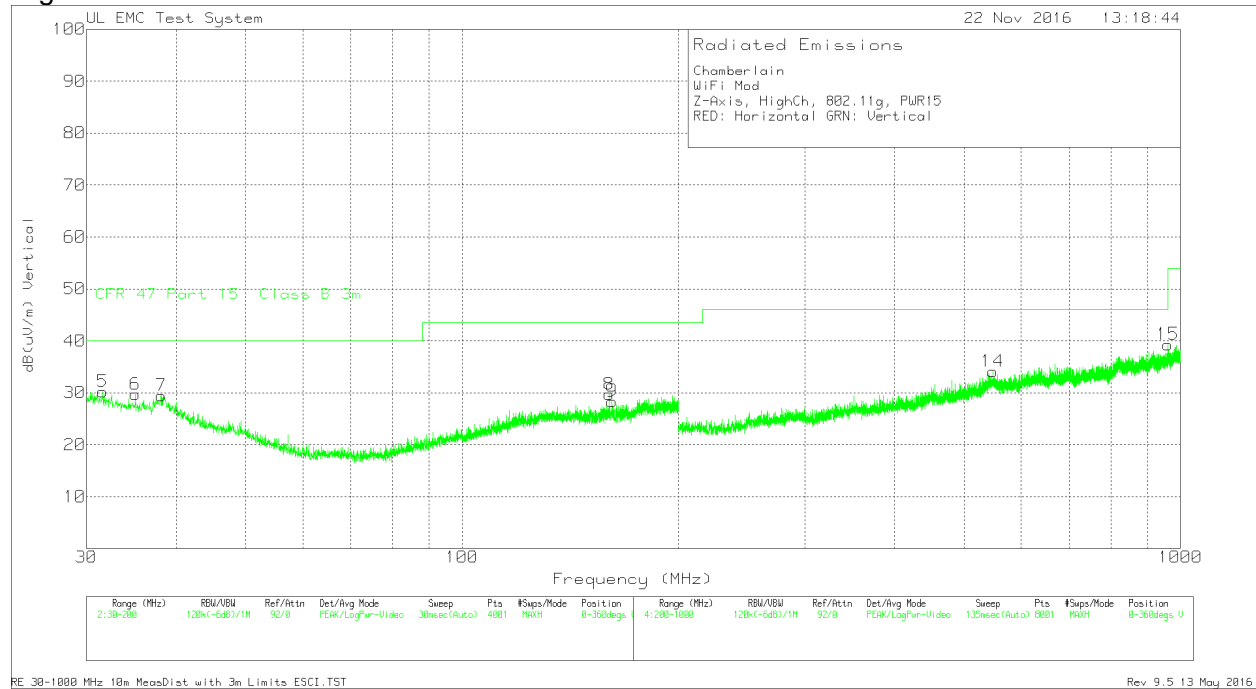

High Channel Data

Chamberlain

WiFi Mod

Z-Axis, HighCh, 802.11g, PWR15

RED: Horizontal GRN: Vertical

Trace Markers

Test No.	Frequency (MHz)	Meter Reading	Transducer Factor (dB)	Gain/Loss Factor (dB)	Corrected Reading (uV/m)	Limit:1 (dB)
1	30.3825	31.33dBuV Pk	18	-19.5	29.83	40
		Azimuth:0-360	Height:398	Horz	Margin (dB)	-10.17
2	160.0925	33.88dBuV Pk	14.9	-19	29.78	43.52
		Azimuth:0-360	Height:398	Horz	Margin (dB)	-13.74
3	181.1725	33.33dBuV Pk	15.5	-18.7	30.13	43.52
		Azimuth:0-360	Height:248	Horz	Margin (dB)	-13.39
4	192.35	33.66dBuV Pk	16	-18.4	31.26	43.52
		Azimuth:0-360	Height:248	Horz	Margin (dB)	-12.26
5	31.615	32.2dBuV Pk	17.5	-19.5	30.2	40
		Azimuth:0-360	Height:101	Vert	Margin (dB)	-9.8
6	35.1	32.89dBuV Pk	16.2	-19.4	29.69	40
		Azimuth:0-360	Height:398	Vert	Margin (dB)	-10.31
7	38.1175	33.88dBuV Pk	15.1	-19.5	29.48	40
		Azimuth:0-360	Height:101	Vert	Margin (dB)	-10.52
8	160.0925	33.77dBuV Pk	14.9	-19	29.67	43.52
		Azimuth:0-360	Height:251	Vert	Margin (dB)	-13.85
9	161.7075	32.46dBuV Pk	14.9	-19	28.36	43.52
		Azimuth:0-360	Height:251	Vert	Margin (dB)	-15.16
10	538.5	32.11dBuV Pk	19.5	-17.2	34.41	46.02
		Azimuth:0-360	Height:399	Horz	Margin (dB)	-11.61
11	551.1	31.48dBuV Pk	19.8	-17.1	34.18	46.02
		Azimuth:0-360	Height:399	Horz	Margin (dB)	-11.84
12	892.6	33.06dBuV Pk	22.6	-17.1	38.56	46.02
		Azimuth:0-360	Height:399	Horz	Margin (dB)	-7.46
13	942.6	32.22dBuV Pk	23.2	-17	38.42	46.02
		Azimuth:0-360	Height:199	Horz	Margin (dB)	-7.6
14	547.7	31.2dBuV Pk	20	-17.1	34.1	46.02
		Azimuth:0-360	Height:399	Vert	Margin (dB)	-11.92
15	960.8	32.59dBuV Pk	23.6	-16.9	39.29	53.97
		Azimuth:0-360	Height:299	Vert	Margin (dB)	-14.68

LIMIT 1: CFR 47 Part 15 Class B 3m

Pk - Peak detector

9.3.8. SPURIOUS EMISSIONS 30 TO 1000 MHz for 802.11n

Low Channel Plots

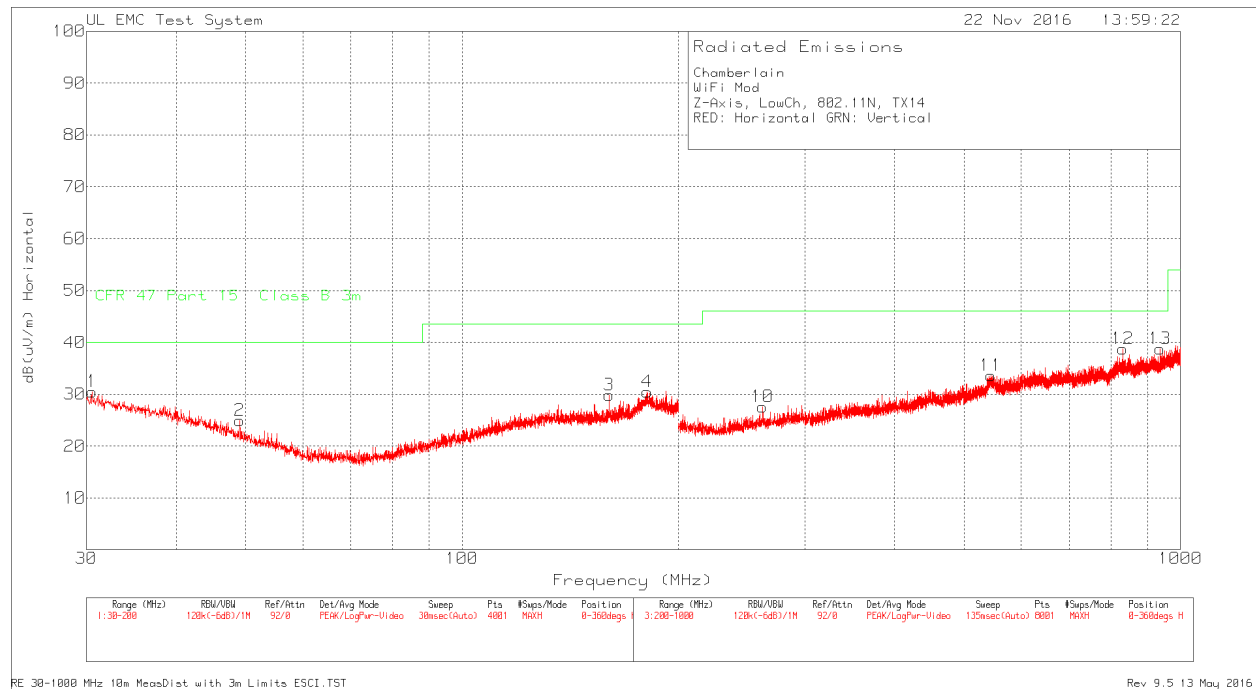
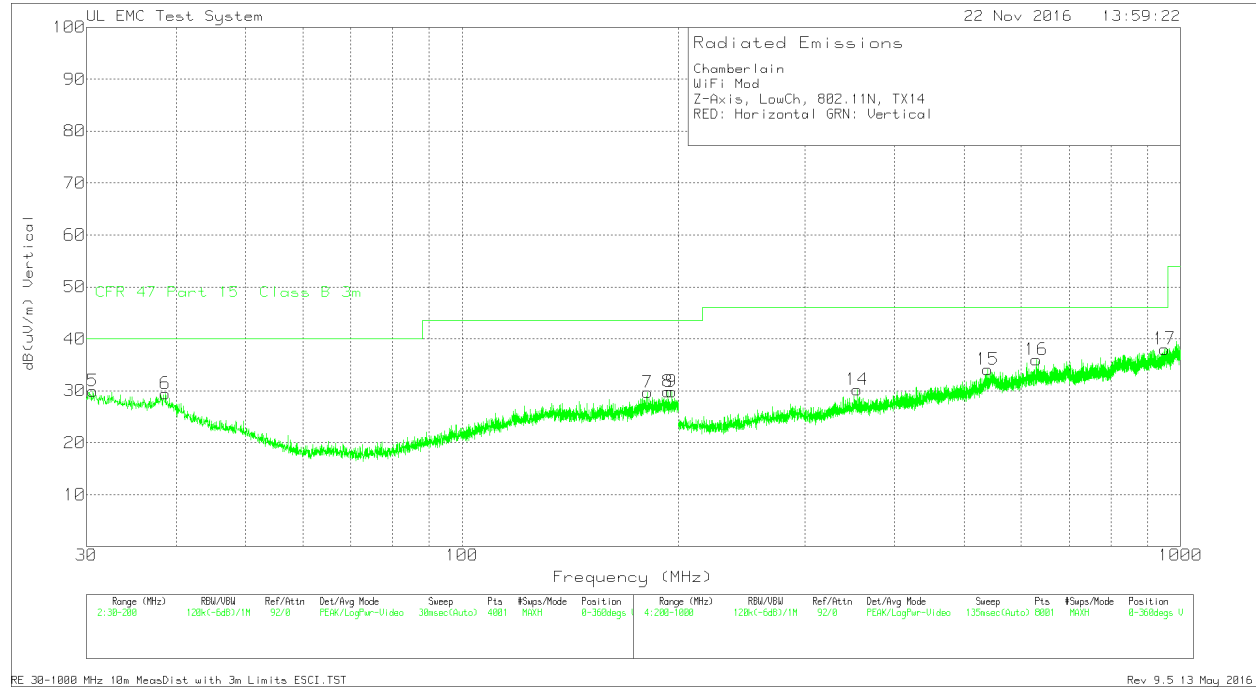

Low Channel Data

Chamberlain
 WiFi Mod
 Z-Axis, LowCh, 802.11N, TX14
 RED: Horizontal GRN: Vertical

Trace Markers

Test No.	Frequency (MHz)	Meter Reading	Transducer Factor (dB)	Gain/Loss Factor (dB)	Corrected Reading (uV/m)	Limit:1 (dB)
1	30.5525	31.99dBuV Pk Azimuth:0-360	18	-19.5	30.49	40
			Height:398	Horz	Margin (dB)	-9.51
2	49.04	33.61dBuV Pk Azimuth:0-360	10.8	-19.5	24.91	40
			Height:102	Horz	Margin (dB)	-15.09
3	160.135	33.91dBuV Pk Azimuth:0-360	14.9	-19	29.81	43.52
			Height:398	Horz	Margin (dB)	-13.71
4	181.045	33.67dBuV Pk Azimuth:0-360	15.5	-18.7	30.47	43.52
			Height:248	Horz	Margin (dB)	-13.05
5	30.6375	31.57dBuV Pk Azimuth:0-360	17.9	-19.5	29.97	40
			Height:101	Vert	Margin (dB)	-10.03
6	38.6275	34.17dBuV Pk Azimuth:0-360	14.8	-19.5	29.47	40
			Height:101	Vert	Margin (dB)	-10.53
7	181.215	32.93dBuV Pk Azimuth:0-360	15.5	-18.7	29.73	43.52
			Height:101	Vert	Margin (dB)	-13.79
8	193.285	32.12dBuV Pk Azimuth:0-360	16	-18.3	29.82	43.52
			Height:398	Vert	Margin (dB)	-13.7
9	195.7075	32.12dBuV Pk Azimuth:0-360	16	-18.3	29.82	43.52
			Height:251	Vert	Margin (dB)	-13.7
10	262.1	33.56dBuV Pk Azimuth:0-360	12.6	-18.6	27.56	46.02
			Height:199	Horz	Margin (dB)	-18.46
11	545	30.68dBuV Pk Azimuth:0-360	20.1	-17.2	33.58	46.02
			Height:299	Horz	Margin (dB)	-12.44
12	830.7	33.61dBuV Pk Azimuth:0-360	22.5	-17.4	38.71	46.02
			Height:99	Horz	Margin (dB)	-7.31
13	935.9	33.01dBuV Pk Azimuth:0-360	22.8	-17.1	38.71	46.02
			Height:199	Horz	Margin (dB)	-7.31
14	354.8	32.98dBuV Pk Azimuth:0-360	15.2	-18	30.18	46.02
			Height:399	Vert	Margin (dB)	-15.84
15	539	31.71dBuV Pk Azimuth:0-360	19.6	-17.2	34.11	46.02
			Height:302	Vert	Margin (dB)	-11.91
16	630	32.3dBuV Pk Azimuth:0-360	20.3	-16.6	36	46.02
			Height:198	Vert	Margin (dB)	-10.02
17	949.8	31.43dBuV Pk Azimuth:0-360	23.5	-16.9	38.03	46.02
			Height:99	Vert	Margin (dB)	-7.99

LIMIT 1: CFR 47 Part 15 Class B 3m
 Pk - Peak detector

Middle Channel Plots

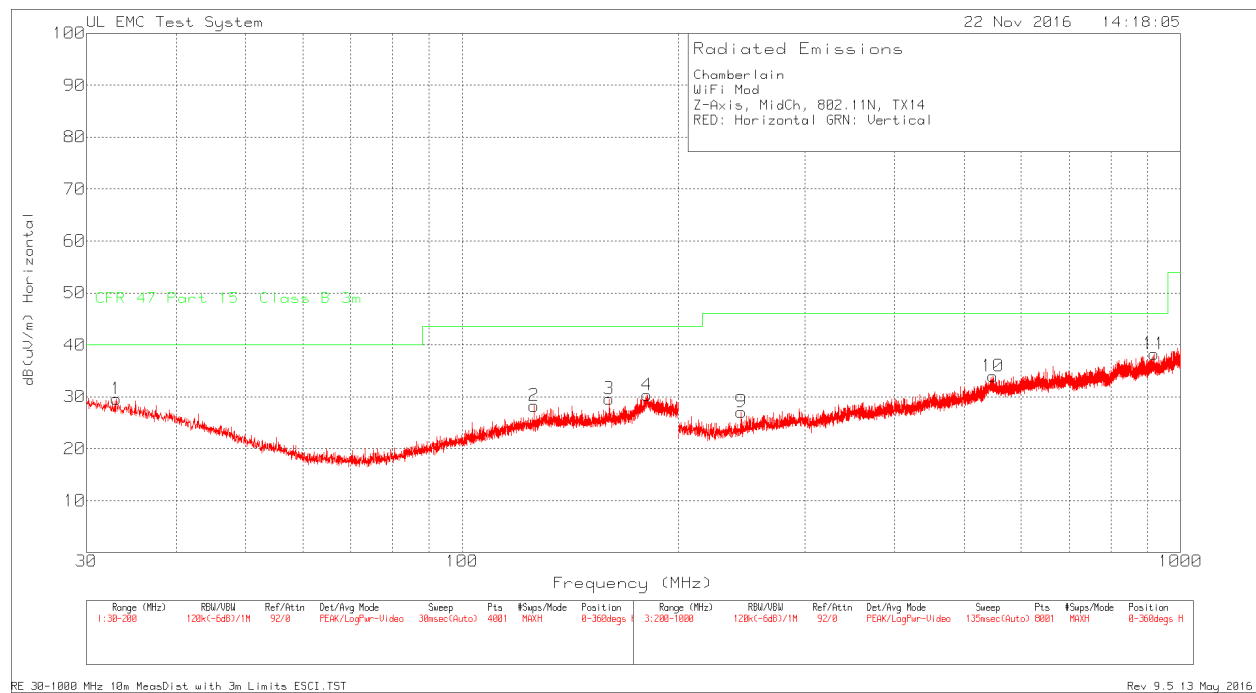
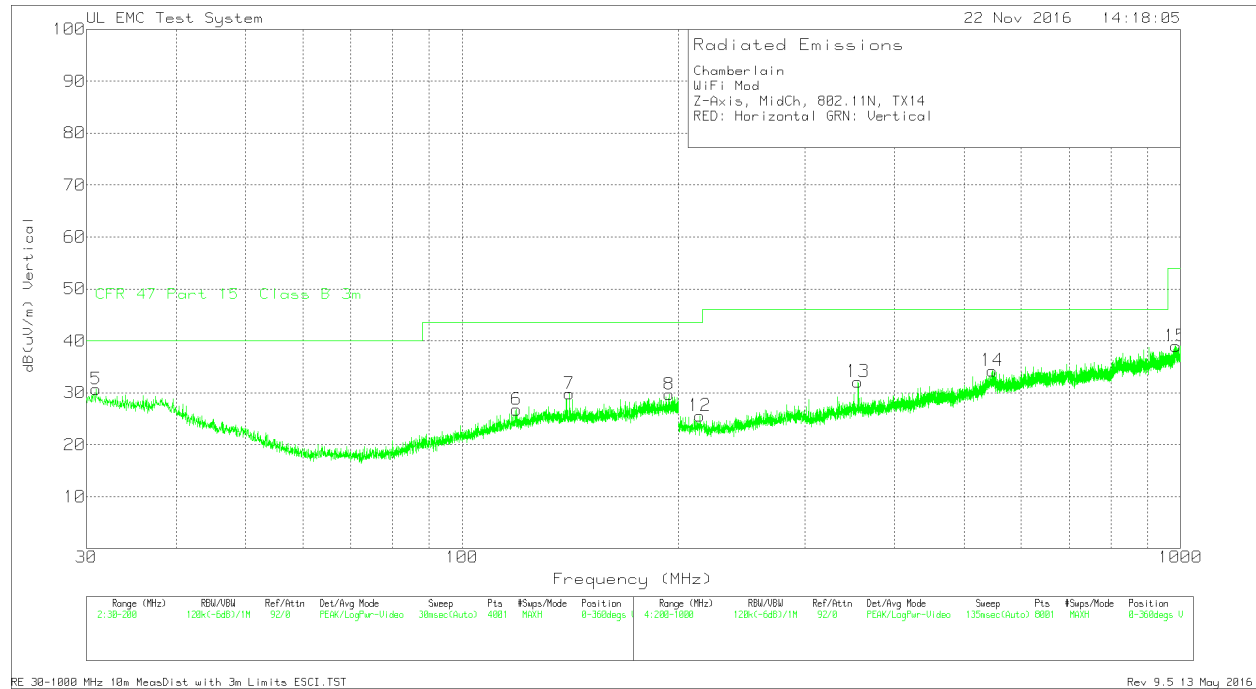

Middle Channel Data

Chamberlain
 WiFi Mod
 Z-Axis, MidCh, 802.11N, TX14
 RED: Horizontal GRN: Vertical

Trace Markers

Test No.	Frequency (MHz)	Meter Reading	Transducer Factor (dB)	Gain/Loss Factor (dB)	Corrected Reading (uV/m)	Limit:1 (dB)
1	33.0175	32.05dBuV Pk	17	-19.5	29.55	40
		Azimuth:0-360	Height:101	Horz	Margin (dB)	-10.45
2	126.0075	33.67dBuV Pk	13.8	-19.2	28.27	43.52
		Azimuth:0-360	Height:398	Horz	Margin (dB)	-15.25
3	160.135	33.72dBuV Pk	14.9	-19	29.62	43.52
		Azimuth:0-360	Height:398	Horz	Margin (dB)	-13.9
4	180.96	33.56dBuV Pk	15.5	-18.7	30.36	43.52
		Azimuth:0-360	Height:248	Horz	Margin (dB)	-13.16
5	30.935	32.43dBuV Pk	17.8	-19.5	30.73	40
		Azimuth:0-360	Height:101	Vert	Margin (dB)	-9.27
6	119.1225	32.66dBuV Pk	13.3	-19.2	26.76	43.52
		Azimuth:0-360	Height:398	Vert	Margin (dB)	-16.76
7	141.0525	34.81dBuV Pk	14.1	-19.1	29.81	43.52
		Azimuth:0-360	Height:101	Vert	Margin (dB)	-13.71
8	194.1775	31.99dBuV Pk	16	-18.3	29.69	43.52
		Azimuth:0-360	Height:398	Vert	Margin (dB)	-13.83
9	244.7	34.22dBuV Pk	11.7	-18.8	27.12	46.02
		Azimuth:0-360	Height:299	Horz	Margin (dB)	-18.9
10	548.2	31.05dBuV Pk	20	-17.1	33.95	46.02
		Azimuth:0-360	Height:299	Horz	Margin (dB)	-12.07
11	918.6	32.35dBuV Pk	23.2	-17.3	38.25	46.02
		Azimuth:0-360	Height:399	Horz	Margin (dB)	-7.77
12	214.4	33.19dBuV Pk	11.4	-19	25.59	43.52
		Azimuth:0-360	Height:102	Vert	Margin (dB)	-17.93
13	355.8	34.94dBuV Pk	15.2	-18	32.14	46.02
		Azimuth:0-360	Height:102	Vert	Margin (dB)	-13.88
14	547.3	31.37dBuV Pk	20	-17.1	34.27	46.02
		Azimuth:0-360	Height:102	Vert	Margin (dB)	-11.75
15	985.6	30.72dBuV Pk	24.4	-16.1	39.02	53.97
		Azimuth:0-360	Height:399	Vert	Margin (dB)	-14.95

LIMIT 1: CFR 47 Part 15 Class B 3m
 Pk - Peak detector

High Channel Plots

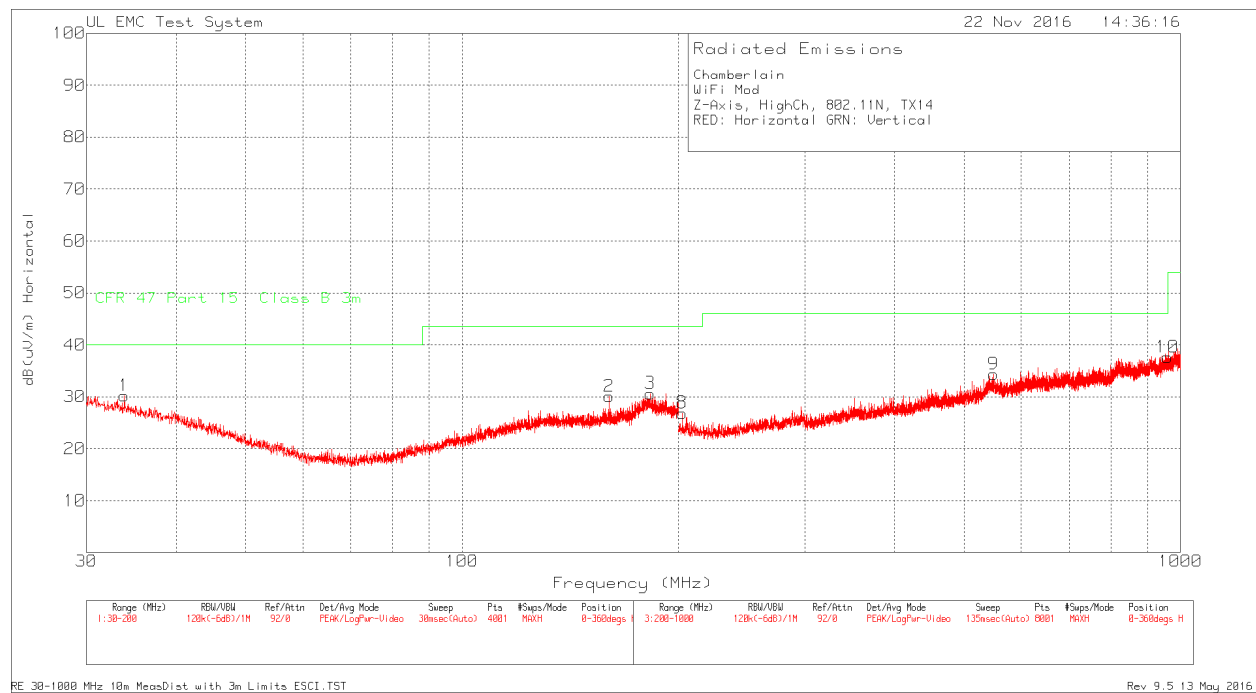
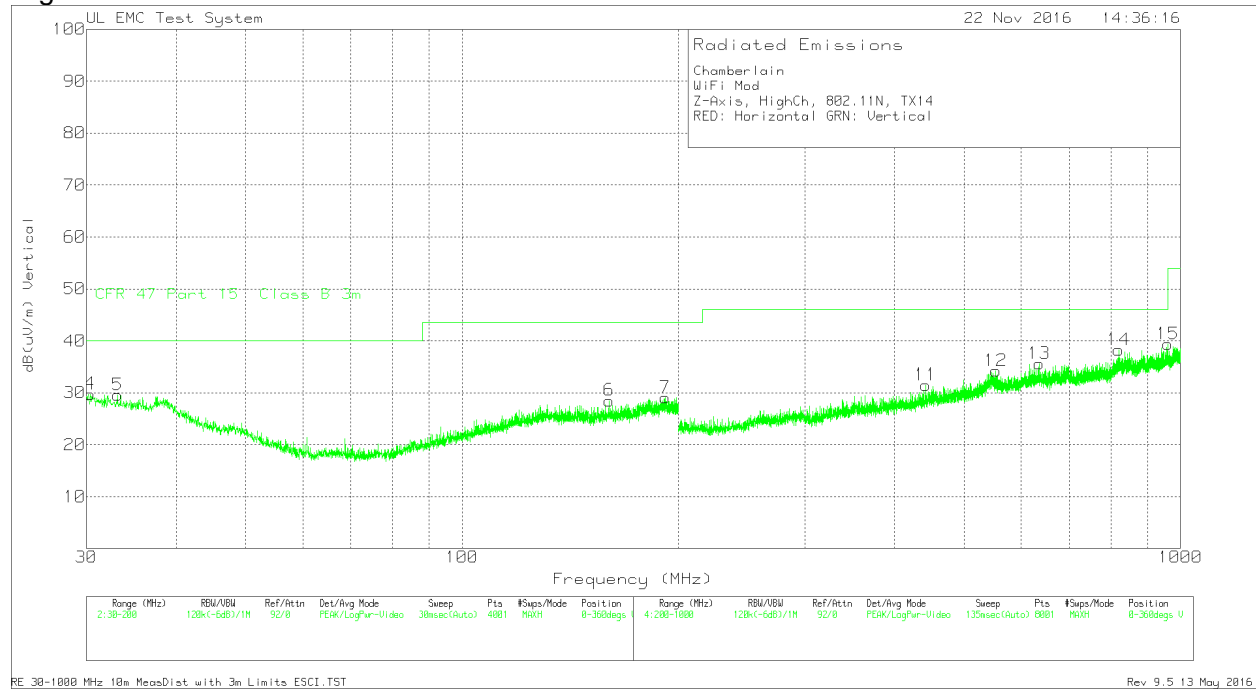

High Channel Data

Chamberlain

WiFi Mod

Z-Axis, HighCh, 802.11N, TX14

RED: Horizontal GRN: Vertical

Trace Markers

Test No.	Frequency (MHz)	Meter Reading	Transducer Factor (dB)	Gain/Loss Factor (dB)	Corrected Reading (uV/m)	Limit:1 (dB)
1	33.8675	33.01dBuV Pk	16.7	-19.5	30.21	40
		Azimuth:0-360	Height:398	Horz	Margin (dB)	-9.79
2	160.0925	34.21dBuV Pk	14.9	-19	30.11	43.52
		Azimuth:0-360	Height:398	Horz	Margin (dB)	-13.41
3	182.7025	33.73dBuV Pk	15.6	-18.7	30.63	43.52
		Azimuth:0-360	Height:248	Horz	Margin (dB)	-12.89
4	30.3825	31.26dBuV Pk	18	-19.5	29.76	40
		Azimuth:0-360	Height:102	Vert	Margin (dB)	-10.24
5	33.145	32.2dBuV Pk	16.9	-19.5	29.6	40
		Azimuth:0-360	Height:251	Vert	Margin (dB)	-10.4
6	160.0925	32.61dBuV Pk	14.9	-19	28.51	43.52
		Azimuth:0-360	Height:251	Vert	Margin (dB)	-15.01
7	191.925	31.45dBuV Pk	16	-18.4	29.05	43.52
		Azimuth:0-360	Height:102	Vert	Margin (dB)	-14.47
8	202.5	34.47dBuV Pk	11.4	-19	26.87	43.52
		Azimuth:0-360	Height:199	Horz	Margin (dB)	-16.65
9	549.6	31.53dBuV Pk	19.9	-17.1	34.33	46.02
		Azimuth:0-360	Height:399	Horz	Margin (dB)	-11.69
10	959.3	30.94dBuV Pk	23.6	-16.9	37.64	46.02
		Azimuth:0-360	Height:199	Horz	Margin (dB)	-8.38
11	442	32.5dBuV Pk	16.7	-17.7	31.5	46.02
		Azimuth:0-360	Height:99	Vert	Margin (dB)	-14.52
12	553.3	31.72dBuV Pk	19.6	-17.1	34.22	46.02
		Azimuth:0-360	Height:99	Vert	Margin (dB)	-11.8
13	636.3	31.83dBuV Pk	20.5	-16.7	35.63	46.02
		Azimuth:0-360	Height:299	Vert	Margin (dB)	-10.39
14	820	32.64dBuV Pk	22.8	-17.2	38.24	46.02
		Azimuth:0-360	Height:399	Vert	Margin (dB)	-7.78
15	959.6	32.64dBuV Pk	23.6	-16.9	39.34	46.02
		Azimuth:0-360	Height:99	Vert	Margin (dB)	-6.68

LIMIT 1: CFR 47 Part 15 Class B 3m

Pk - Peak detector

10. AC POWER LINE CONDUCTED EMISSIONS

LIMITS

FCC §15.207 (a)

RSS-Gen 7.2.2

Frequency of Emission (MHz)	Conducted Limit (dBuV)	
	Quasi-peak	Average
0.15-0.5	66 to 56*	56 to 46*
0.5-5	56	46
5-30	60	50

*Decreases with the logarithm of the frequency.

TEST PROCEDURE

The EUT is placed on a non-conducting table 40 cm from the vertical ground plane and 80 cm above the horizontal ground plane. The EUT is configured in accordance with ANSI C63.10.

The receiver is set to a resolution bandwidth of 9 kHz. Peak detection is used unless otherwise noted as quasi-peak or average.

Line conducted data is recorded for both NEUTRAL and HOT lines.

RESULTS for 802.11b

Conducted Emissions Plots

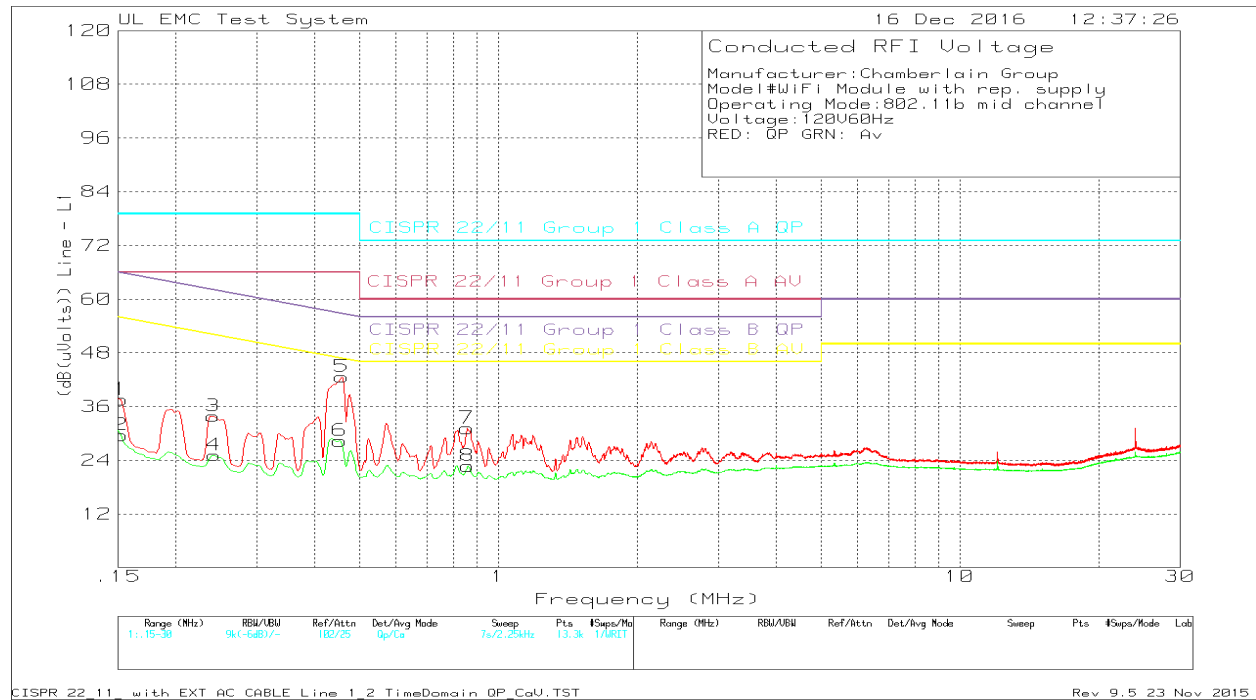
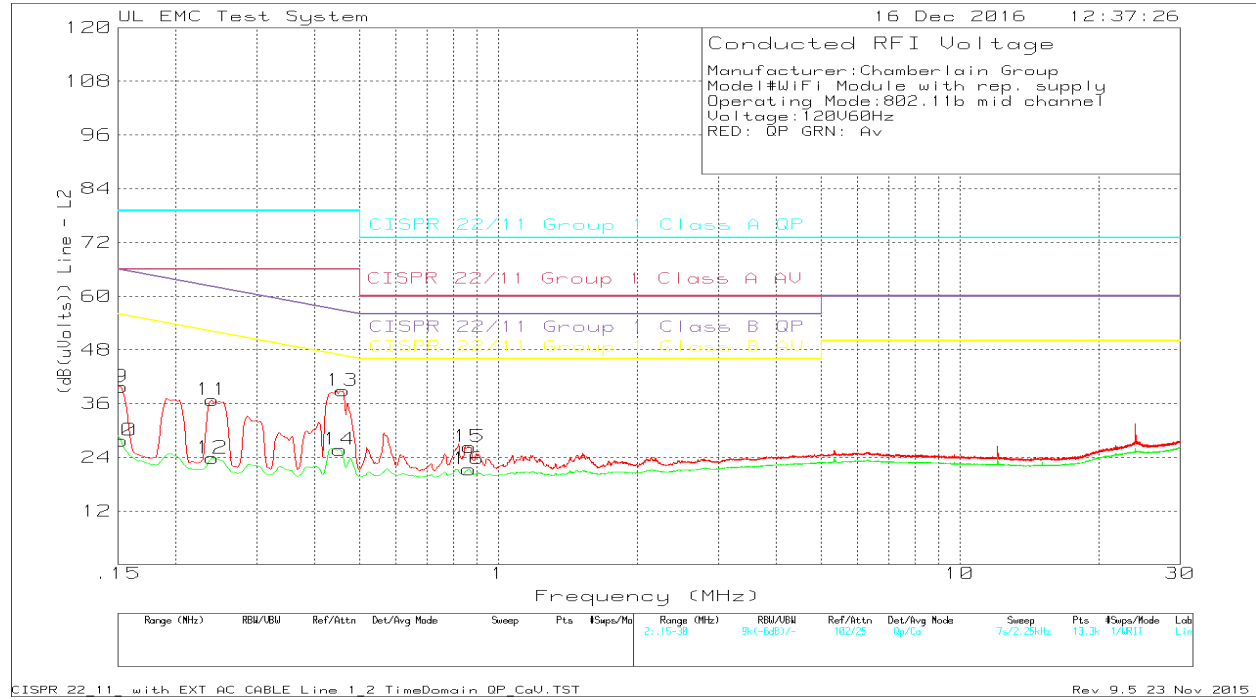

Conducted Emissions Data

Manufacturer:Chamberlain Group
 Model#WiFi Module with rep. supply
 Operating Mode:802.11b mid channel
 Voltage:120V60Hz
 RED: QP GRN: Av

Trace Markers									
No.	Test Frequency (MHz)	Meter Reading	Transducer Factor (dB)	Gain/Loss Factor (dB)	Corrected Reading (dB(uVolts))	Limit:1	2	3	4
Line									
1	.15225	23.84dBuV	Qp	.1	13.6	37.54	79	-	65.88
						Margin (dB)	-41.46	-	-28.34
2	.15225	15.92dBuV	Ca	.1	13.6	29.62	-	66	-
						Margin (dB)	-	-36.38	-
3	.24113	22.57dBuV	Qp	0	11.3	33.87	79	-	62.06
						Margin (dB)	-45.13	-	-28.19
4	.24225	13.85dBuV	Ca	0	11.3	25.15	-	66	-
						Margin (dB)	-	-40.85	-
5	.45825	31.93dBuV	Qp	0	10.7	42.63	79	-	56.72
						Margin (dB)	-36.37	-	-14.09
6	.45375	17.68dBuV	Ca	0	10.7	28.38	-	66	-
						Margin (dB)	-	-37.62	-
7	.8565	20.54dBuV	Qp	0	10.6	31.14	73	-	56
						Margin (dB)	-41.86	-	-24.86
8	.85875	12.13dBuV	Ca	0	10.6	22.73	-	60	-
						Margin (dB)	-	-37.27	-
Netural									
9	.15225	25.42dBuV	Qp	.1	14.2	39.72	79	-	65.88
						Margin (dB)	-39.28	-	-26.16
10	.15225	13.42dBuV	Ca	.1	14.2	27.72	-	66	-
						Margin (dB)	-	-38.28	-
11	.24	24.82dBuV	Qp	.1	11.9	36.82	79	-	62.1
						Margin (dB)	-42.18	-	-25.28
12	.24	11.77dBuV	Ca	.1	11.9	23.77	-	66	-
						Margin (dB)	-	-42.23	-
13	.4605	27.71dBuV	Qp	0	11.2	38.91	79	-	56.68
						Margin (dB)	-40.09	-	-17.77
14	.45375	14.51dBuV	Ca	0	11.2	25.71	-	66	-
						Margin (dB)	-	-40.29	-
15	.8655	15.24dBuV	Qp	0	11.1	26.34	73	-	56
						Margin (dB)	-46.66	-	-29.66
16	.86325	10.22dBuV	Ca	0	11.1	21.32	-	60	-
						Margin (dB)	-	-38.68	-

LIMIT 1: CISPR 22/11 Group 1 Class A QP
 LIMIT 2: CISPR 22/11 Group 1 Class A AV
 LIMIT 3: CISPR 22/11 Group 1 Class B QP
 LIMIT 4: CISPR 22/11 Group 1 Class B AV

Qp - Quasi-Peak detector
 Ca - CISPR Average detection

RESULTS for 802.11g

Conducted Emissions Plots

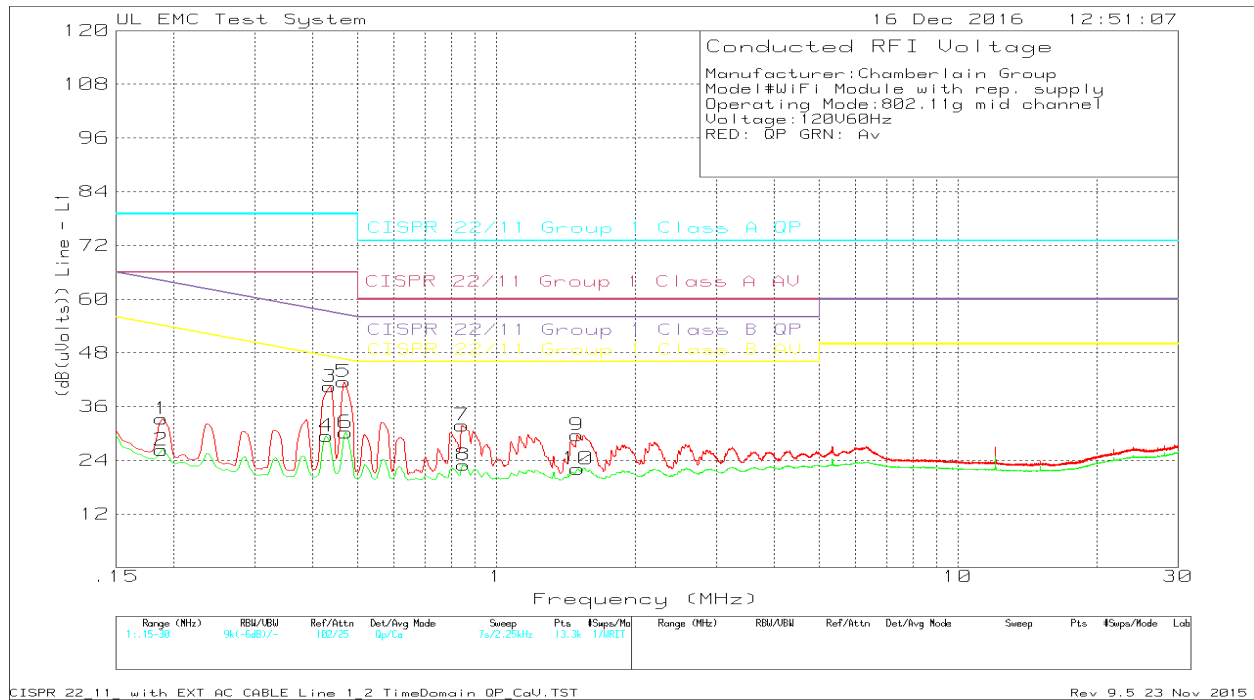
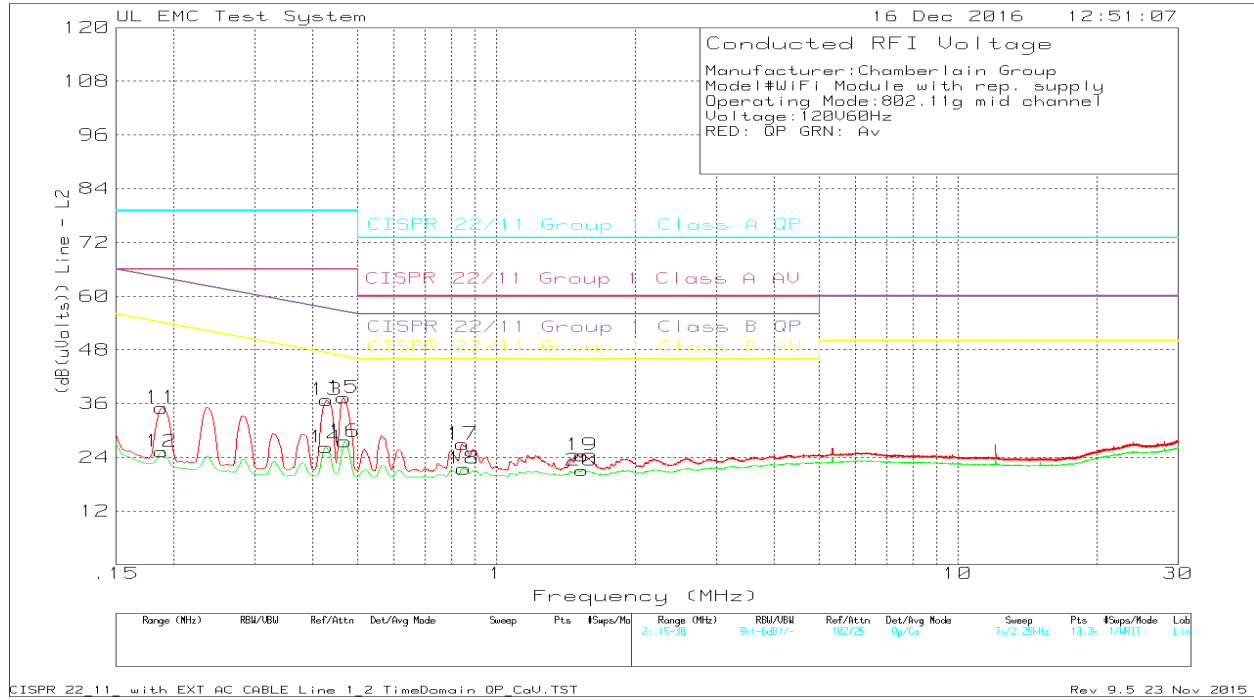

Conducted Emissions Data

Manufacturer:Chamberlain Group
 Model#WiFi Module with rep. supply
 Operating Mode:802.11g mid channel
 Voltage:120V60Hz
 RED: QP GRN: Av

Trace Markers

Test No.	Frequency (MHz)	Meter Reading	Transducer Factor (dB)	Gain/Loss Factor (dB)	Corrected Reading (dB(uVolts))	Limit:1	2	3	4	
=====										
Line										
1	.18825	21.65dBuV	Qp	0	11.6	33.25	79	-	64.11	-
						Margin (dB)	-45.75	-	-30.86	-
2	.18825	14.68dBuV	Ca	0	11.6	26.28	-	66	-	54.11
						Margin (dB)	-	-39.72	-	-27.83
3	.43575	29.78dBuV	Qp	0	10.7	40.48	79	-	57.14	-
						Margin (dB)	-38.52	-	-16.66	-
4	.429	18.7dBuV	Ca	0	10.7	29.4	-	66	-	47.27
						Margin (dB)	-	-36.6	-	-17.87
5	.46725	30.85dBuV	Qp	0	10.7	41.55	79	-	56.56	-
						Margin (dB)	-37.45	-	-15.01	-
6	.47175	19.5dBuV	Ca	0	10.7	30.2	-	66	-	46.48
						Margin (dB)	-	-35.8	-	-16.28
7	.843	21.21dBuV	Qp	0	10.6	31.81	73	-	56	-
						Margin (dB)	-41.19	-	-24.19	-
8	.84975	12.36dBuV	Ca	0	10.6	22.96	-	60	-	46
						Margin (dB)	-	-37.04	-	-23.04
9	1.49663	19dBuV	Qp	0	10.6	29.6	73	-	56	-
						Margin (dB)	-43.4	-	-26.4	-
10	1.50113	11.48dBuV	Ca	0	10.6	22.08	-	60	-	46
						Margin (dB)	-	-37.92	-	-23.92
Neutral										
11	.18825	22.84dBuV	Qp	.1	12.1	35.04	79	-	64.11	-
						Margin (dB)	-43.96	-	-29.07	-
12	.18825	13.07dBuV	Ca	.1	12.1	25.27	-	66	-	54.11
						Margin (dB)	-	-40.73	-	-28.84
13	.429	25.51dBuV	Qp	0	11.3	36.81	79	-	57.27	-
						Margin (dB)	-42.19	-	-20.46	-
14	.42787	14.92dBuV	Ca	0	11.3	26.22	-	66	-	47.29
						Margin (dB)	-	-39.78	-	-21.07
15	.46725	26.13dBuV	Qp	0	11.2	37.33	79	-	56.56	-
						Margin (dB)	-41.67	-	-19.23	-
16	.4695	16.34dBuV	Ca	0	11.2	27.54	-	66	-	46.52
						Margin (dB)	-	-38.46	-	-18.98
17	.84525	15.82dBuV	Qp	0	11.1	26.92	73	-	56	-
						Margin (dB)	-46.08	-	-29.08	-
18	.852	10.37dBuV	Ca	0	11.1	21.47	-	60	-	46
						Margin (dB)	-	-38.53	-	-24.53
19	1.53375	13.36dBuV	Qp	0	11.1	24.46	73	-	56	-
						Margin (dB)	-48.54	-	-31.54	-
20	1.53375	9.99dBuV	Ca	0	11.1	21.09	-	60	-	46
						Margin (dB)	-	-38.91	-	-24.91

LIMIT 1: CISPR 22/11 Group 1 Class A QP
 LIMIT 2: CISPR 22/11 Group 1 Class A AV
 LIMIT 3: CISPR 22/11 Group 1 Class B QP
 LIMIT 4: CISPR 22/11 Group 1 Class B AV

Qp - Quasi-Peak detector
 Ca - CISPR Average detection

RESULTS for 802.11n

Conducted Emissions Plots

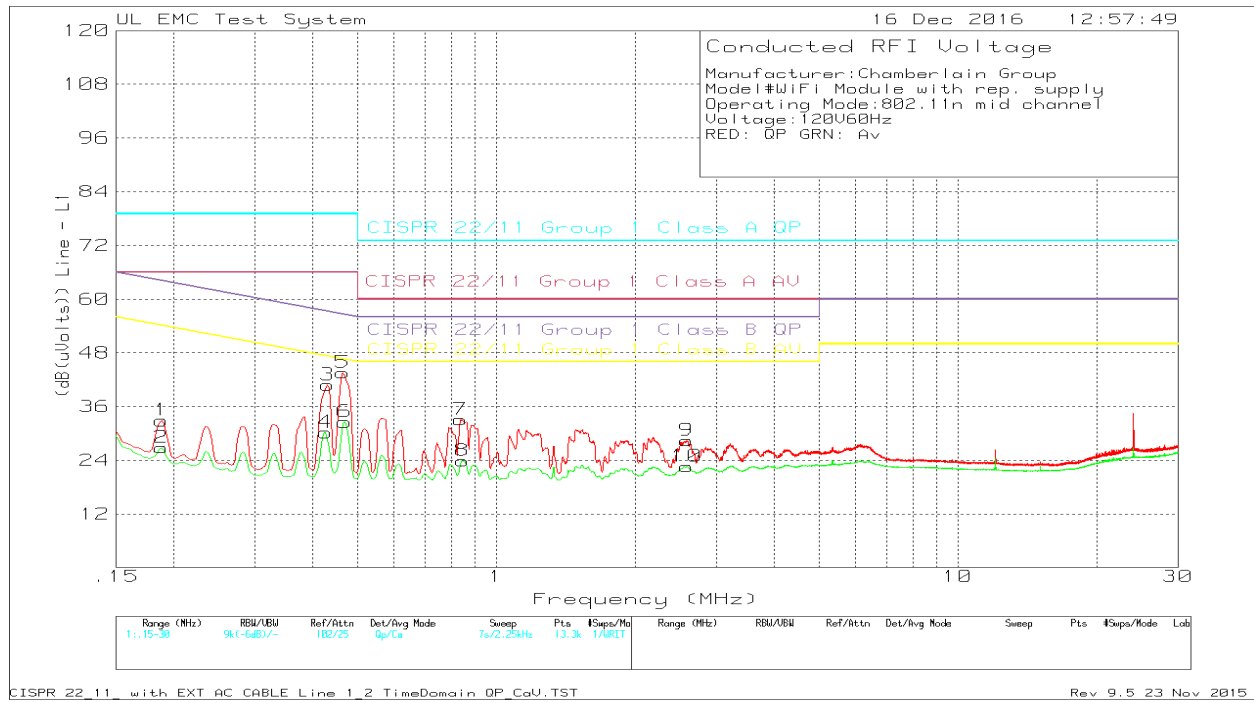
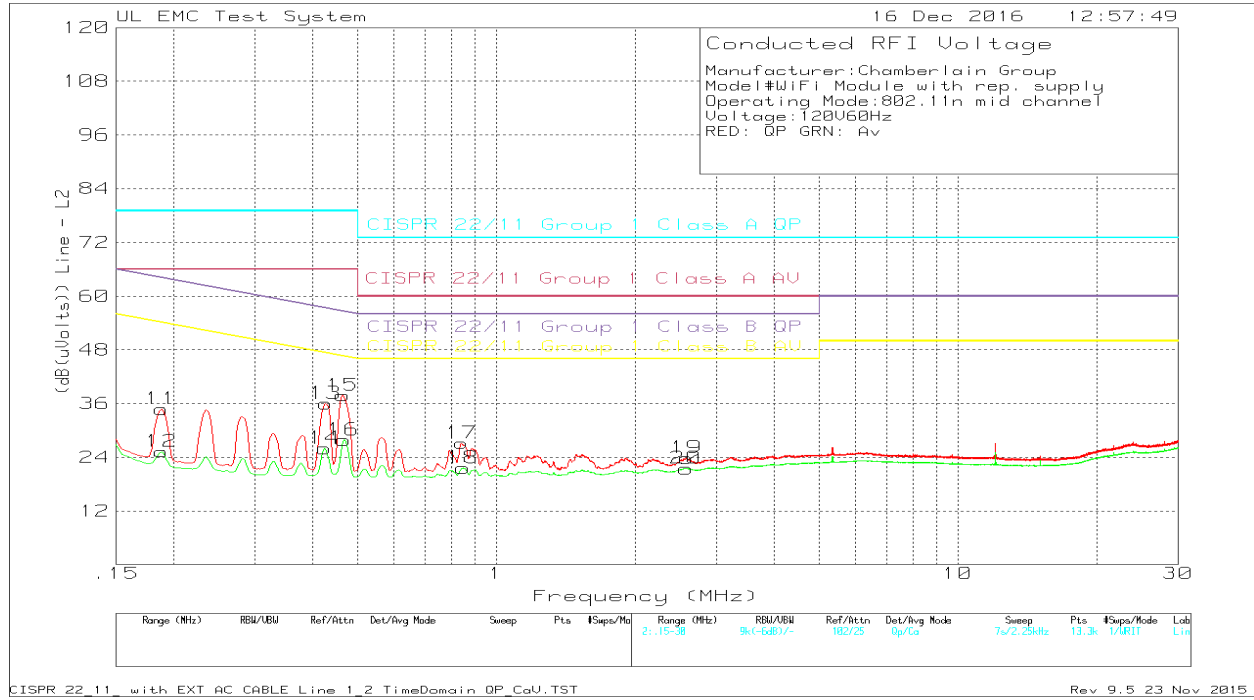

Conducted Emissions Data

Manufacturer:Chamberlain Group
 Model#WiFi Module with rep. supply
 Operating Mode:802.11n mid channel
 Voltage:120V60Hz
 RED: QP GRN: Av

Trace Markers

Test No.	Frequency (MHz)	Meter Reading	Transducer Factor (dB)	Gain/Loss Factor (dB)	Corrected Reading (dB(uVolts))	Limit:1	2	3	4	
=====										
Line										
1	.18825	21.29dBuV	Qp	0	11.6	32.89	79	-	64.11	-
						Margin (dB)	-46.11	-	-31.22	-
2	.18825	15.24dBuV	Ca	0	11.6	26.84	-	66	-	54.11
						Margin (dB)	-	-39.16	-	-27.27
3	.43125	30.12dBuV	Qp	0	10.7	40.82	79	-	57.23	-
						Margin (dB)	-38.18	-	-16.41	-
4	.42675	19.51dBuV	Ca	0	10.7	30.21	-	66	-	47.32
						Margin (dB)	-	-35.79	-	-17.11
5	.465	32.87dBuV	Qp	0	10.7	43.57	79	-	56.6	-
						Margin (dB)	-35.43	-	-13.03	-
6	.4695	21.9dBuV	Ca	0	10.7	32.6	-	66	-	46.52
						Margin (dB)	-	-33.4	-	-13.92
7	.83625	22.48dBuV	Qp	0	10.6	33.08	73	-	56	-
						Margin (dB)	-39.92	-	-22.92	-
8	.84525	13.3dBuV	Ca	0	10.6	23.9	-	60	-	46
						Margin (dB)	-	-36.1	-	-22.1
9	2.58675	17.82dBuV	Qp	0	10.6	28.42	73	-	56	-
						Margin (dB)	-44.58	-	-27.58	-
10	2.58675	12.02dBuV	Ca	0	10.6	22.62	-	60	-	46
						Margin (dB)	-	-37.38	-	-23.38
Neutral										
11	.18825	22.56dBuV	Qp	.1	12.1	34.76	79	-	64.11	-
						Margin (dB)	-44.24	-	-29.35	-
12	.18825	13.07dBuV	Ca	.1	12.1	25.27	-	66	-	54.11
						Margin (dB)	-	-40.73	-	-28.84
13	.42675	24.67dBuV	Qp	0	11.3	35.97	79	-	57.32	-
						Margin (dB)	-43.03	-	-21.35	-
14	.4245	14.67dBuV	Ca	0	11.3	25.97	-	66	-	47.36
						Margin (dB)	-	-40.03	-	-21.39
15	.465	26.63dBuV	Qp	0	11.2	37.83	79	-	56.6	-
						Margin (dB)	-41.17	-	-18.77	-
16	.46725	16.67dBuV	Ca	0	11.2	27.87	-	66	-	46.56
						Margin (dB)	-	-38.13	-	-18.69
17	.84075	16.06dBuV	Qp	0	11.1	27.16	73	-	56	-
						Margin (dB)	-45.84	-	-28.84	-
18	.8475	10.49dBuV	Ca	0	11.1	21.59	-	60	-	46
						Margin (dB)	-	-38.41	-	-24.41
19	2.5845	12.75dBuV	Qp	0	11.1	23.85	73	-	56	-
						Margin (dB)	-49.15	-	-32.15	-
20	2.57775	10.41dBuV	Ca	0	11.1	21.51	-	60	-	46
						Margin (dB)	-	-38.49	-	-24.49

LIMIT 1: CISPR 22/11 Group 1 Class A QP
 LIMIT 2: CISPR 22/11 Group 1 Class A AV
 LIMIT 3: CISPR 22/11 Group 1 Class B QP
 LIMIT 4: CISPR 22/11 Group 1 Class B AV

Qp - Quasi-Peak detector
 Ca - CISPR Average detection

11. SETUP PHOTOS

ANTENNA PORT CONDUCTED RF MEASUREMENT SETUP

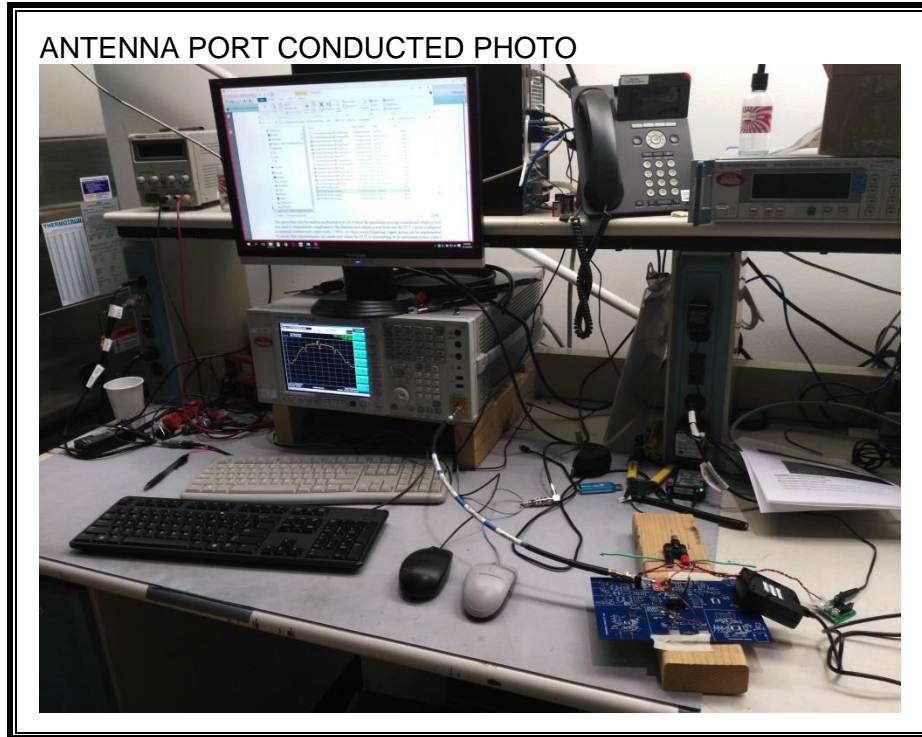

RADIATED RF MEASUREMENT SETUP (BELOW 1 GHz)

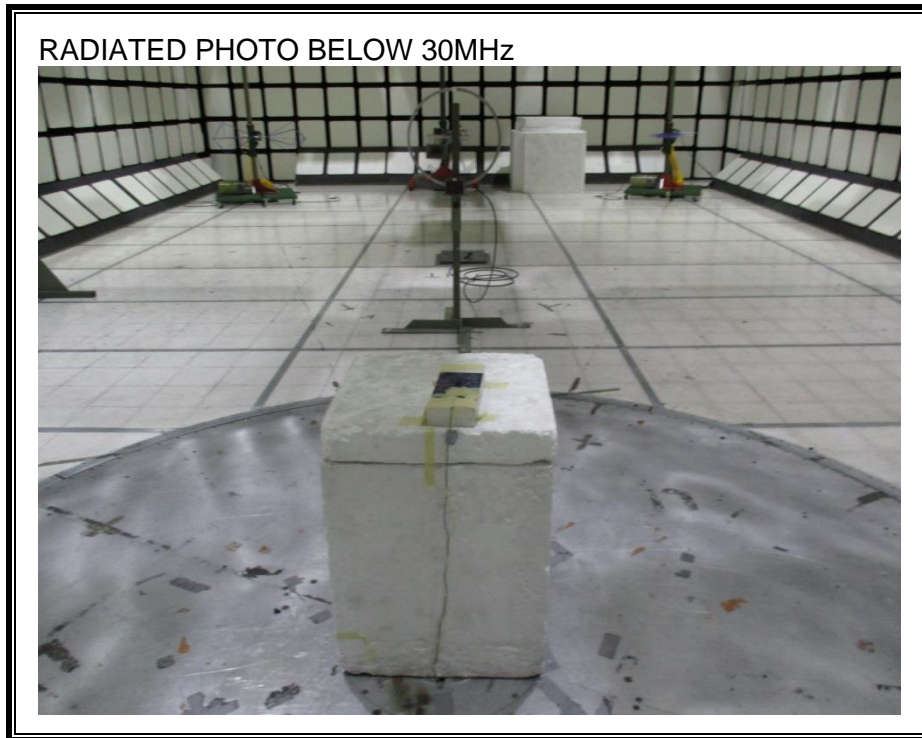

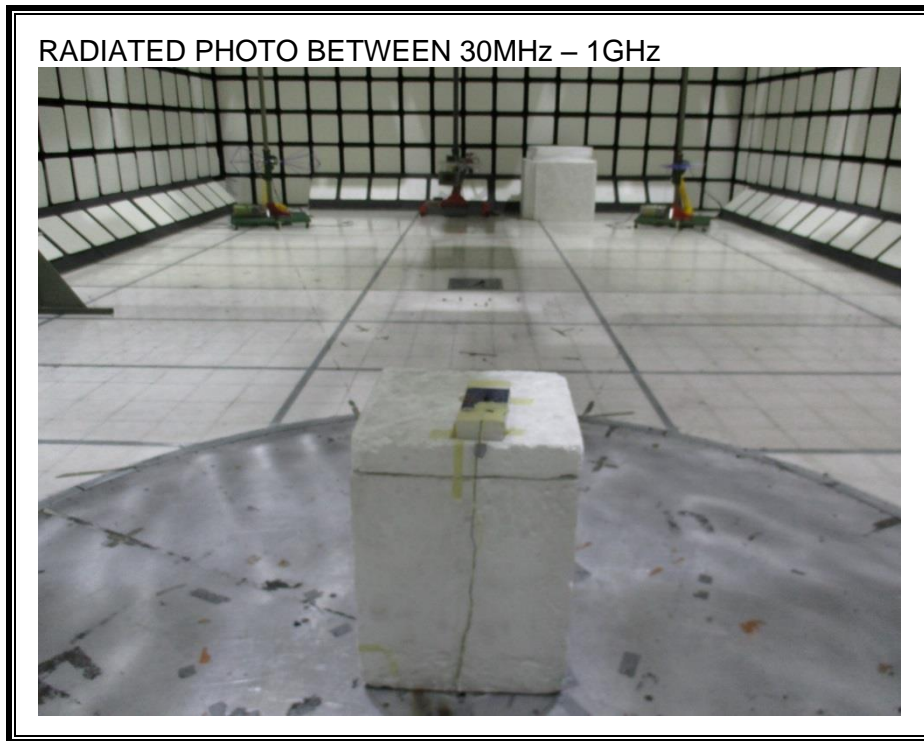

RADIATED RF MEASUREMENT SETUP (ABOVE 1 GHz)

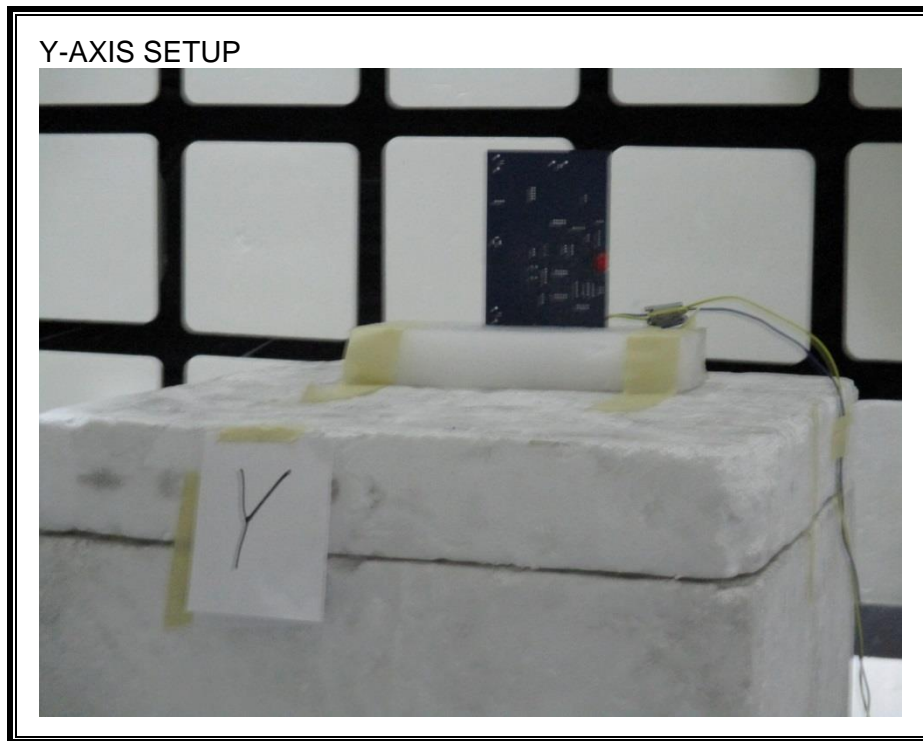
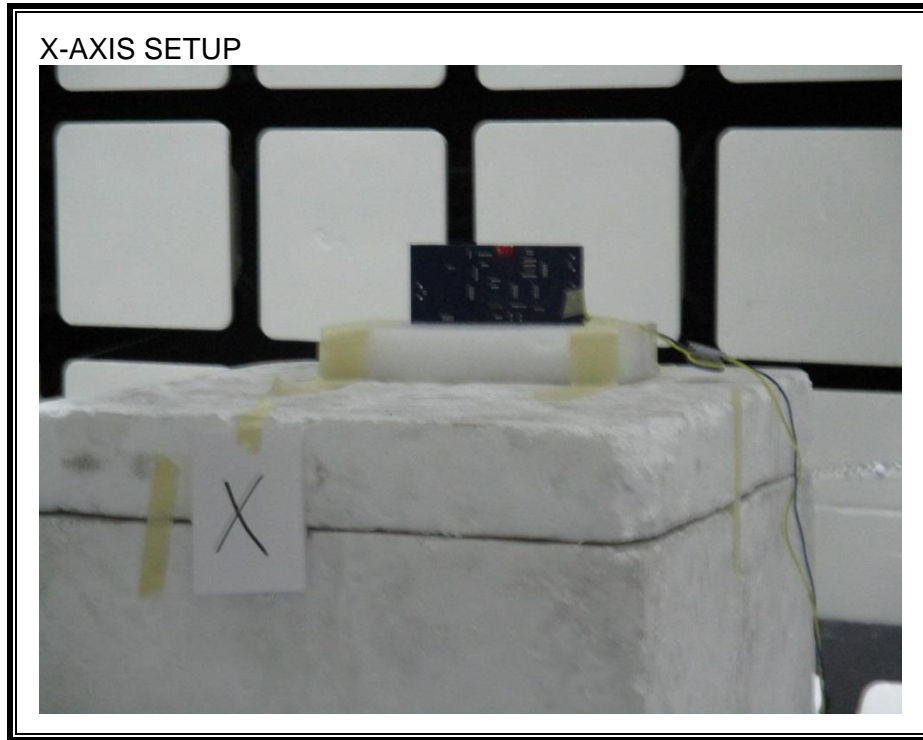

Z-AXIS SETUP



1 - 25GHz

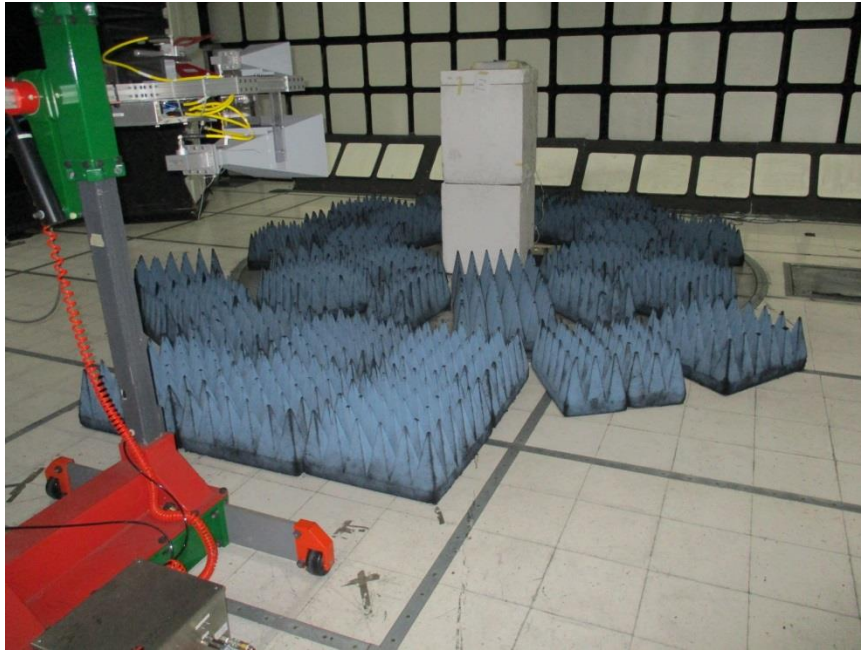

1 – 25GHz



Line Conducted Emissions

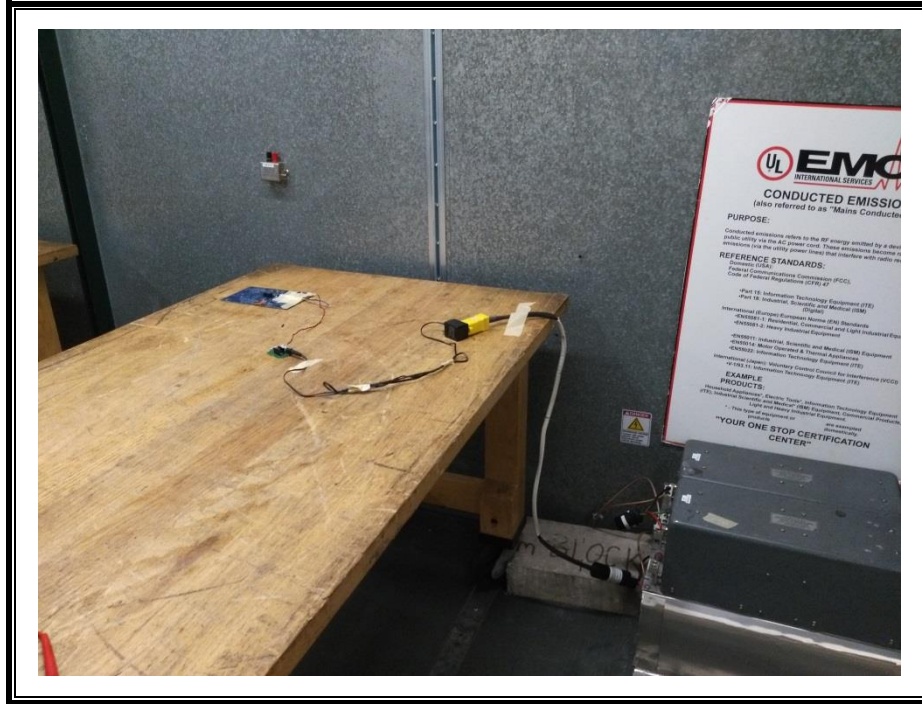

END OF REPORT