

Test REPORT

Applicant: Chamberlain Group Inc, The
Address of Applicant: 845 Larch Avenue, Elmhurst, IL 60126

Equipment Under Test (EUT)

Product Name: Keypad Access Controller
Model No.: KPW5
FCC ID: HBW190A1808-1

Applicable standards: FCC CFR Title 47 Part 15 Subpart C Section 15.231;
RSS 210; RSS-Gen

Date of sample receipt: Feb. 09, 2015

Date of Test: Feb. 10, to Mar. 09, 2015

Date of report issued: Mar. 10, 2015

Test Result : PASS *

* In the configuration tested, the EUT complied with the standards specified above.

2 Version

Version No.	Date	Description
00	Mar. 10, 2015	Original

Prepared By:

Beryl zhao

Date:

Mar. 10, 2015

Report Clerk

Check By:

Zou & Co

Date:

Mar. 10, 2015

EMC Manger

3 Contents

	Page
1 COVER PAGE	1
2 Version	2
3 Contents.....	3
4 Test Summary.....	4
5 General Information	5
5.1 Client Information	5
5.2 General Description of E.U.T.....	5
5.3 Test mode.....	6
5.4 Description of Support Units	6
5.5 Laboratory Facility	6
5.6 Measuremet uncertainty	7
5.7 Laboratory Location	7
5.8 Other Information Requested by the Customer	7
5.9 Test Instruments list.....	8
6 Test results and Measurement Data	9
6.1 Antenna requirement:	9
6.2 Conducted Emission	10
6.3 Radiated Emission	11
6.4 Bandwidth Test	23
6.5 Manually Activated Transmitter	26

4 Test Summary

Test Item	Section in CFR 47	Result
Antenna requirement	15.203	Pass
AC Power Line Conducted Emission	15.207; RSS-Gen	N.A.
Manually Activated Transmitter	15.231(a); RSS-210	Pass
Radiation Emission	15.231(b), 15.205, 15.209, 15.35; RSS-210; RSS-Gen	Pass
Occupied Bandwidth	15.231(c); RSS-210	Pass

Pass: The EUT comply with the essential requirements in the standard.

5 General Information

5.1 Client Information

Applicant:	Chamberlain Group Inc, The
Address of Applicant:	845 Larch Avenue, Elmhurst, IL 60126
Manufacturer:	Chamberlain Group Inc, The
Address of Manufacturer:	845 Larch Avenue, Elmhurst, IL 60126

5.2 General Description of E.U.T.

Product Name:	Keypad Access Controller
Model No.:	KPW5
Brand Name:	Liftmaster
Operation Frequency:	310M, 315M, 390M
Modulation type:	OOK
Antenna Type:	Internal antenna
Antenna gain:	0dBi
Power supply:	DC 9V Battery

Note:

1. For a more detailed features description, please refer to the manufacturer's specifications or the User's Manual.

5.3 Test mode

Operating Environment:	
Temperature:	24.0 °C
Humidity:	54 % RH
Atmospheric Pressure:	1010 mbar
Test mode:	
Operation mode	Keep the EUT in continuous transmitting with modulation
The sample was placed 0.8m above the ground plane of 3m chamber. Measurements in both horizontal and vertical polarities were performed. During the test, each emission was maximized by: having the EUT continuously working, investigated all operating modes, rotated about all 3 axis (X, Y & Z) and considered typical configuration to obtain worst position, manipulating interconnecting cables, rotating the turntable, varying antenna height from 1m to 4m in both horizontal and vertical polarizations. The emissions worst-case are shown in Test Results of the following pages.	

5.4 Description of Support Units

5.5 Laboratory Facility

<p>The test facility is recognized, certified, or accredited by the following organizations:</p> <ul style="list-style-type: none"> ● FCC - Registration No.: 572331 Shenzhen EMC Laboratory: Shenzhen Tongce Testing Lab The 3m Semi-anechoic chamber has been registered and fully described in a report with the (FCC) Federal Communications Commission. The acceptance letter from the FCC is maintained in our files. ● IC - Registration No.: 10668A-1 The 3m Semi-anechoic chamber of Shenzhen TCT Testing Technology Co., Ltd. has been registered by Certification and Engineering Bureau of Industry Canada for radio equipment testing ● CNAS - Registration No.: CNAS L6165 Shenzhen TCT Testing Technology Co., Ltd. is accredited to ISO/IEC 17025:2005 General Requirements for the Competence of Testing and Calibration laboratories for the competence of testing. The Registration No. is CNAS L6165.

5.6 Measurement uncertainty

The reported uncertainty of measurement $y \pm U$, where expanded uncertainty U is based on a standard uncertainty multiplied by a coverage factor of $k=2$, providing a level of confidence of approximately 95 %.

No.	Item	Uncertainty
1	Conducted Emission	$\pm 2.56\text{dB}$
2	RF power, conducted	$\pm 0.12\text{dB}$
3	Spurious emissions, conducted	$\pm 0.11\text{dB}$
4	All emissions, radiated(<1G)	$\pm 3.92\text{dB}$
5	All emissions, radiated(>1G)	$\pm 4.28\text{dB}$
6	Temperature	$\pm 0.1^\circ\text{C}$
7	Humidity	$\pm 1.0\%$

5.7 Laboratory Location

All tests were performed at: Shenzhen Tongce Testing Lab Address: 1F, Leinuo Watch Building, Fuyong Town, Baoan Dist, Shenzhen, China Tel: +86-0755-36638142 Fax: --
--

5.8 Other Information Requested by the Customer

None.

5.9 Test Instruments list

Radiated Emission:						
Item	Test Equipment	Manufacturer	Model No.	Serial No.	Cal. Date (mm-dd-yy)	Cal. Due date (mm-dd-yy)
1	ESPI Test Receiver	ROHDE&SCHWARZ	ESVD	100008	Sep.17, 2014	Sep.16 , 2015
2	Spectrum Analyzer	ROHDE&SCHWARZ	FSEM	848597/001	Sep.17, 2014	Sep.16 , 2015
3	Spectrum Analyzer	ROHDE&SCHWARZ	FSU3	1166.1660.03	Sep.17, 2014	Sep.16, 2015
4	Pre-amplifier	EM Electronics Corporation CO.,LTD	EM30265	07032613	Sep.17, 2014	Sep.16 , 2015
5	Pre-amplifier	HP	8447D	2727A05017	Sep.17, 2014	Sep.16 , 2015
6	Loop antenna	ZHINAN	ZN30900A	12024	Dec.15, 2014	Dec.14 , 2015
7	Broadband Antenna	Schwarzbeck	VULB9163	340	Sep.17, 2014	Sep.16 , 2015
8	Horn Antenna	Schwarzbeck	BBHA 9120D	631	Sep.17, 2014	Sep.16 , 2015
9	Loop antenna	ZHINAN	ZN30900A	12024	Dec.15, 2014	Dec.14 , 2015
10	Coax cable	TCT	N/A	N/A	Sep.14, 2014	Sep.13 , 2015
11	Coax cable	TCT	N/A	N/A	Sep.14, 2014	Sep.13 , 2015
12	Coax cable	TCT	N/A	N/A	Sep.14, 2014	Sep.13 , 2015
13	Coax cable	TCT	N/A	N/A	Sep.14, 2014	Sep.13 , 2015
14	EMI Test Software	Shurple Technology	EZ-EMC	N/A	N/A	N/A

Conducted Emission:						
Item	Test Equipment	Manufacturer	Model No.	Serial No.	Cal. Date (mm-dd-yy)	Cal. Due date (mm-dd-yy)
1	EMI Test Receiver	R&S	ESCS30	100139	Sep.17, 2014	Sep.16 , 2015
2	LISN-1	AFJ	LS16C	16010947251	Sep.17, 2014	Sep.16 , 2015
3	LISN-2	Schwarzbeck	NSLK 8126	8126453	Sep.17, 2014	Sep.16 , 2015
4	Coax cable	TCT	N/A	164080	Sep.17, 2014	Sep.16 , 2015
5	EMI Test Software	Shurple Technology	EZ-EMC	N/A	N/A	N/A

Conducted method test:						
Item	Test Equipment	Manufacturer	Model No.	Serial No.	Cal. Date (mm-dd-yy)	Cal. Due date (mm-dd-yy)
1	Spectrum Analyzer	ROHDE&SCHWARZ	FSU3	200054	Sep.17, 2014	Sep.16, 2015
2	Spectrum Analyzer	Agilent	N9020A	MY49100060	Oct. 22,2014	Oct. 21 ,2015

6 Test results and Measurement Data

6.1 Antenna requirement:

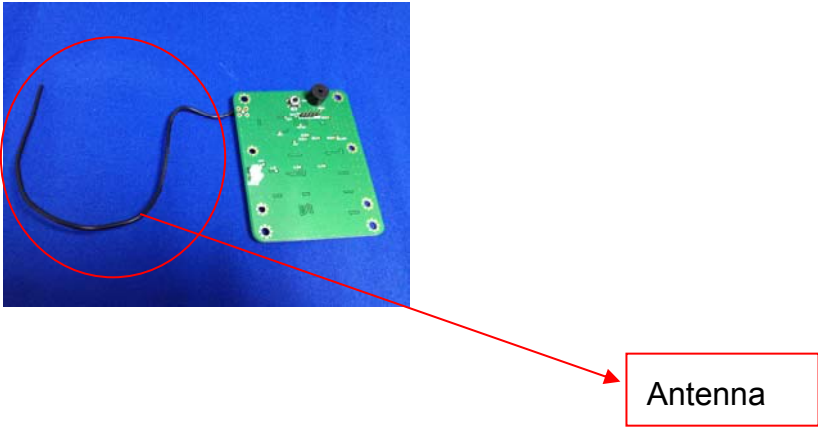
Standard requirement:	FCC Part15 C Section 15.203
15.203 requirement: <i>An intentional radiator shall be designed to ensure that no antenna other than that furnished by the responsible party shall be used with the device. The use of a permanently attached antenna or of an antenna that uses a unique coupling to the intentional radiator, the manufacturer may design the unit so that a broken antenna can be replaced by the user, but the use of a standard antenna jack or electrical connector is prohibited.</i>	
E.U.T Antenna:	
The antenna is an internal antenna which cannot replace by end-user, the best case gain of the antenna is 0 dBi.	
	

6.2 Conducted Emission

Test Requirement:	FCC Part15 C Section 15.207; RSS-Gen														
Test Method:	ANSI C63.4: 2009														
Test Frequency Range:	150 kHz to 30 MHz														
Class / Severity:	Class B														
Receiver setup:	RBW=9 kHz, VBW=30 kHz														
Limit:	<table border="1"> <thead> <tr> <th rowspan="2">Frequency range (MHz)</th> <th colspan="2">Limit (dBuV)</th> </tr> <tr> <th>Quasi-peak</th> <th>Average</th> </tr> </thead> <tbody> <tr> <td>0.15-0.5</td> <td>66 to 56*</td> <td>56 to 46*</td> </tr> <tr> <td>0.5-5</td> <td>56</td> <td>46</td> </tr> <tr> <td>5-30</td> <td>60</td> <td>50</td> </tr> </tbody> </table>	Frequency range (MHz)	Limit (dBuV)		Quasi-peak	Average	0.15-0.5	66 to 56*	56 to 46*	0.5-5	56	46	5-30	60	50
	Frequency range (MHz)		Limit (dBuV)												
		Quasi-peak	Average												
	0.15-0.5	66 to 56*	56 to 46*												
0.5-5	56	46													
5-30	60	50													
* Decreases with the logarithm of the frequency.															
Test procedure	<ol style="list-style-type: none"> The E.U.T and simulators are connected to the main power through a line impedance stabilization network (L.I.S.N.), which provides a 50ohm/50uH coupling impedance for the measuring equipment. The peripheral devices are also connected to the main power through a LISN that provides a 50ohm/50uH coupling impedance with 50ohm termination. (Please refer to the block diagram of the test setup and photographs). Both sides of A.C. line are checked for maximum conducted interference. In order to find the maximum emission, the relative positions of equipment and all of the interface cables must be changed according to ANSI C63.4: 2009 on conducted measurement. 														
Test setup:	<p>Remark: E.U.T: Equipment Under Test LISN: Line Impedance Stabilization Network Test table height=0.8m</p>														
Test Instruments:	Refer to section 5.9 for details														
Test mode:	Refer to section 5.3 for details														
Test results:	N/A														

Remark: The EUT is powered by battery, so the term is not applicable.

6.3 Radiated Emission

Test Requirement:	FCC Part15 C Section 15.231 and 15.209; RSS-210; RSS-GEN																																	
Test Method:	ANSI C63.4:2009 for FCC; ANSI C63.10:2013 for IC																																	
Test Frequency Range:	9KHz to 1000MHz																																	
Test site:	Measurement Distance: 3m																																	
Receiver setup:	<p>Tabel 1</p> <table border="1"> <thead> <tr> <th>Frequency</th> <th>Detector</th> <th>RBW</th> <th>VBW</th> <th>Remark</th> </tr> </thead> <tbody> <tr> <td>9kHz- 150kHz</td> <td>Quasi-peak</td> <td>200Hz</td> <td>1kHz</td> <td>Quasi-peak Value</td> </tr> <tr> <td>150kHz- 30MHz</td> <td>Quasi-peak</td> <td>9kHz</td> <td>30kHz</td> <td>Quasi-peak Value</td> </tr> <tr> <td>30MHz-1GHz</td> <td>Quasi-peak</td> <td>100kHz</td> <td>300kHz</td> <td>Quasi-peak Value</td> </tr> <tr> <td rowspan="2">Above 1GHz</td> <td>Peak</td> <td>1MHz</td> <td>3MHz</td> <td>Peak Value</td> </tr> <tr> <td>Peak</td> <td>1MHz</td> <td>10Hz</td> <td>Average Value</td> </tr> </tbody> </table>	Frequency	Detector	RBW	VBW	Remark	9kHz- 150kHz	Quasi-peak	200Hz	1kHz	Quasi-peak Value	150kHz- 30MHz	Quasi-peak	9kHz	30kHz	Quasi-peak Value	30MHz-1GHz	Quasi-peak	100kHz	300kHz	Quasi-peak Value	Above 1GHz	Peak	1MHz	3MHz	Peak Value	Peak	1MHz	10Hz	Average Value				
Frequency	Detector	RBW	VBW	Remark																														
9kHz- 150kHz	Quasi-peak	200Hz	1kHz	Quasi-peak Value																														
150kHz- 30MHz	Quasi-peak	9kHz	30kHz	Quasi-peak Value																														
30MHz-1GHz	Quasi-peak	100kHz	300kHz	Quasi-peak Value																														
Above 1GHz	Peak	1MHz	3MHz	Peak Value																														
	Peak	1MHz	10Hz	Average Value																														
Limit: (Field strength of the fundamental signal)	<p>According to 15.231(b) requirements, the field strength of emissions from intentional radiators operated under this Section shall not exceed the following</p> <p>Tabel 2</p> <table border="1"> <thead> <tr> <th>Fundamental Frequency (MHz)</th> <th>Filed Strength of Fundamental (microvolts/meter)</th> <th>Filed Strength of Spurious Emission (microvolts/meter)</th> </tr> </thead> <tbody> <tr> <td>40.66-40.70</td> <td>2250</td> <td>225</td> </tr> <tr> <td>70-130</td> <td>1250</td> <td>125</td> </tr> <tr> <td>130-174</td> <td>1250 to 3750*</td> <td>125 to 375*</td> </tr> <tr> <td>174-260</td> <td>3750</td> <td>375</td> </tr> <tr> <td>260-470</td> <td>3750 to 12500*</td> <td>375 to 1250*</td> </tr> <tr> <td>Above 470</td> <td>12500</td> <td>1250</td> </tr> </tbody> </table> <p>*Linear interpolations</p> <p>[Where F is the frequency in MHz, the formulas for calculating the maximum permitted fundamental field strengths are as follows: for the band 130-174 MHz, $\mu\text{V/m}$ at 3 meters = $56.81818(F) - 6136.3636$; for the band 260-470 MHz, $\mu\text{V/m}$ at 3 meters = $41.6667(F) - 7083.3333$. The maximum permitted unwanted emission level is 20 dB below the maximum permitted fundamental level.]</p> <p>Tabel 3</p> <table border="1"> <thead> <tr> <th>Working Frequency(MHz)</th> <th>Filed Strength of Fundamental(dB $\mu\text{V/m}$)</th> <th>Filed Strength of Spurious Emission(dB $\mu\text{V/m}$)</th> </tr> </thead> <tbody> <tr> <td>310</td> <td>75.32</td> <td>55.32</td> </tr> <tr> <td>315</td> <td>75.62</td> <td>55.62</td> </tr> <tr> <td>390</td> <td>79.24</td> <td>59.24</td> </tr> </tbody> </table> <p>Intentional radiators operating under the provisions of this Section shall demonstrate compliance with the limits on the field strength of emissions, as shown in the above table, based on the average value of the measured emissions.</p> <p>Note1: According to 15.35, on any frequency or frequencies below or equal to 1000 MHz, the limits Shown are based on measuring equipment employing a CISPR quasi-peak detector function and related measurement bandwidths, unless otherwise specified the limit on peak radio frequency emissions is 20dB above the maximum permitted average emission limit applicable to the equipment under test.</p>	Fundamental Frequency (MHz)	Filed Strength of Fundamental (microvolts/meter)	Filed Strength of Spurious Emission (microvolts/meter)	40.66-40.70	2250	225	70-130	1250	125	130-174	1250 to 3750*	125 to 375*	174-260	3750	375	260-470	3750 to 12500*	375 to 1250*	Above 470	12500	1250	Working Frequency(MHz)	Filed Strength of Fundamental(dB $\mu\text{V/m}$)	Filed Strength of Spurious Emission(dB $\mu\text{V/m}$)	310	75.32	55.32	315	75.62	55.62	390	79.24	59.24
Fundamental Frequency (MHz)	Filed Strength of Fundamental (microvolts/meter)	Filed Strength of Spurious Emission (microvolts/meter)																																
40.66-40.70	2250	225																																
70-130	1250	125																																
130-174	1250 to 3750*	125 to 375*																																
174-260	3750	375																																
260-470	3750 to 12500*	375 to 1250*																																
Above 470	12500	1250																																
Working Frequency(MHz)	Filed Strength of Fundamental(dB $\mu\text{V/m}$)	Filed Strength of Spurious Emission(dB $\mu\text{V/m}$)																																
310	75.32	55.32																																
315	75.62	55.62																																
390	79.24	59.24																																

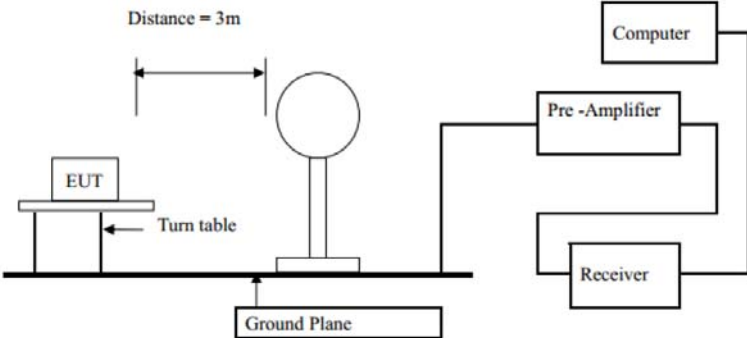
<p>Limit: (Spurious Emissions)</p>	<p>Table 4</p> <table border="1" data-bbox="571 241 1453 479"> <thead> <tr> <th>Frequency</th> <th>Limit (dBuV/m @3m)</th> <th>Remark</th> </tr> </thead> <tbody> <tr> <td>30MHz-88MHz</td> <td>40.00</td> <td>Quasi-peak Value</td> </tr> <tr> <td>88MHz-216MHz</td> <td>43.50</td> <td>Quasi-peak Value</td> </tr> <tr> <td>216MHz-960MHz</td> <td>46.00</td> <td>Quasi-peak Value</td> </tr> <tr> <td>960MHz-1GHz</td> <td>54.00</td> <td>Quasi-peak Value</td> </tr> <tr> <td rowspan="2">Above 1GHz</td> <td>54.00</td> <td>Average Value</td> </tr> <tr> <td>74.00</td> <td>Peak Value</td> </tr> </tbody> </table> <p>Note2: According to 15.231(b) , The limits on the field strength of the spurious emissions in the table 3 are based on the fundamental frequency of the intentional radiator. Spurious emissions shall be attenuated to the average (or, alternatively, CISPR quasi-peak) limits shown in this table 3 or to the general limits shown in the table 4, whichever limit permits a higher field strength.</p>	Frequency	Limit (dBuV/m @3m)	Remark	30MHz-88MHz	40.00	Quasi-peak Value	88MHz-216MHz	43.50	Quasi-peak Value	216MHz-960MHz	46.00	Quasi-peak Value	960MHz-1GHz	54.00	Quasi-peak Value	Above 1GHz	54.00	Average Value	74.00	Peak Value
Frequency	Limit (dBuV/m @3m)	Remark																			
30MHz-88MHz	40.00	Quasi-peak Value																			
88MHz-216MHz	43.50	Quasi-peak Value																			
216MHz-960MHz	46.00	Quasi-peak Value																			
960MHz-1GHz	54.00	Quasi-peak Value																			
Above 1GHz	54.00	Average Value																			
	74.00	Peak Value																			
<p>Test Procedure:</p>	<ol style="list-style-type: none"> 1. The EUT was placed on the top of a rotating table 0.8 meters above the ground at a 3 meter camber. The table was rotated 360 degrees to determine the position of the highest radiation. 2. The EUT was set 3 meters away from the interference-receiving antenna, which was mounted on the top of a variable-height antenna tower. 3. The antenna height is varied from one meter to four meters above the ground to determine the maximum value of the field strength. Both horizontal and vertical polarizations of the antenna are set to make the measurement. 4. For each suspected emission, the EUT was arranged to its worst case and then the antenna was tuned to heights from 1 meter to 4 meters and the rotatable table was turned from 0 degrees to 360 degrees to find the maximum reading. 5. The test-receiver system was set to Peak Detect Function and Specified Bandwidth with Maximum Hold Mode. 6. If the emission level of the EUT in peak mode was 10dB lower than the limit specified, then testing could be stopped and the peak values of the EUT would be reported. Otherwise the emissions that did not have 10dB margin would be re-tested one by one using peak, quasi-peak or average method as specified and then reported in a data sheet. 																				
<p>Test setup:</p>	<p>For radiated emissions below 30MHz</p>  <p>30MHz to 1GHz</p>																				

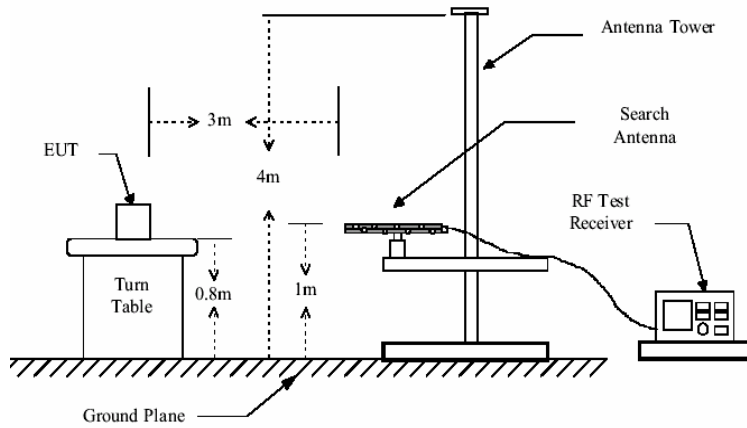

Above 1GHz for FCC

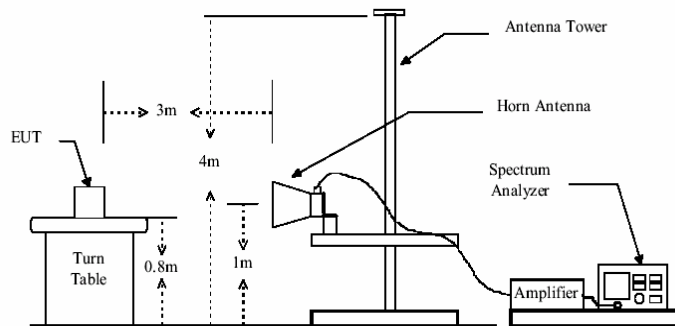

Above 1GHz for IC

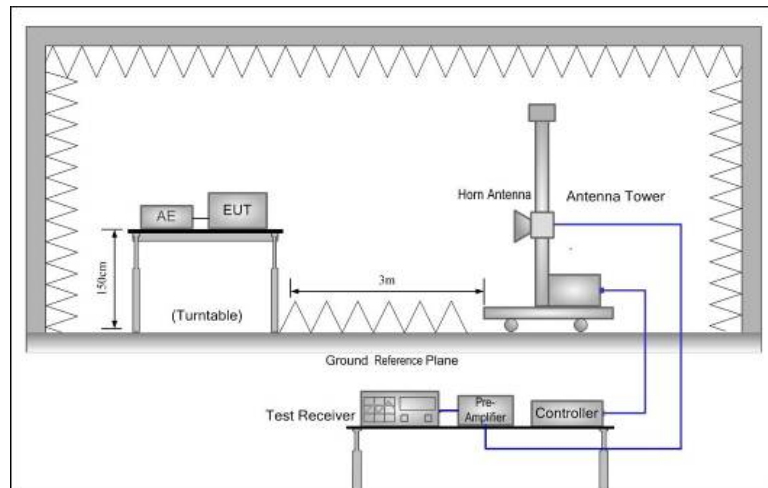

Test Instruments:	Refer to section 5.9
Test mode:	Refer to section 5.3
Test results:	Passed
Remark:	<ol style="list-style-type: none"> 1. Pre-scan all kind of the place mode (X-axis, Y-axis, Z-axis), and found the Y-axis is the worst case. 2. 9 kHz to 30MHz is too low, the emission levels are 20 dB below the limit value, so only shows the data of above 30MHz in this report

Measured data:

For 310MHz:

A Fundamental Radiated Emission

Frequency (MHz)	Emission Level@3m (dBμV/m)	Antenna Polarity	Limit@3m (dBμV/m)	Remark
310	83.33	H	95.32	Peak
310	82.03	V	95.32	Peak

Frequency (MHz)	Peak Emission Level@3m (dBμV/m)	AV Factor (dB)	AV Emission Level@3m (dBμV/m)	Antenna Polarity	Limit@3m (dBμV/m)	Remark
310	83.33	-16.48	66.85	H	75.32	AV
310	82.03	-16.48	65.55	V	75.32	AV

B Harmonics and spurious Radiated Emission

Below 1G

Frequency (MHz)	Emission Level@3m (dBμV/m)	Antenna Polarity	Limit@3m (dBμV/m)	Remark
256.19	17.33	H	46.00	QP
620.00	52.29	H	55.32	QP
930.00	46.73	H	55.32	QP
256.19	19.40	V	46.00	QP
620.00	51.37	V	55.32	QP
930.00	42.05	V	55.32	QP

Above 1G For FCC

Frequency (MHz)	Peak Emission Level@3m (dBμV/m)	AV Factor (dB)	AV Emission Level@3m (dBμV/m)	Antenna Polarity	Limit@3m (dBμV/m)	Remark
1240.00	44.81	-16.48	28.33	H	54.00	AV
1860.00	37.69	-16.48	21.21	H	55.32	AV
1240.00	40.27	-16.48	23.79	V	54.00	AV
1860.00	49.35	-16.48	32.87	V	55.32	AV

Above 1G For IC

Frequency (MHz)	Peak Emission Level@3m (dB μ V/m)	AV Factor (dB)	AV Emission Level@3m (dB μ V/m)	Antenna Polarity	Limit@3m (dB μ V/m)	Remark
1240.00	45.03	-16.48	28.55	H	54.00	AV
1860.00	38.14	-16.48	21.66	H	55.32	AV
1240.00	39.85	-16.48	23.37	V	54.00	AV
1860.00	48.79	-16.48	32.31	V	55.32	AV

- Note:
- 1) Emission Level=Reading+ Cable loss+ Antenna factor-Amp factor
Test Frequency form 9kHz to 5GHz, the emission levels are 20 dB below the limit value, which are not reported. It is deemed to comply with the requirement
 - 3) AV=Average
 - 4) AV Emission level = Peak Emissions level +AV Factor
 - 5) AV Factor = 20 log(Duty Cycle)

Duty cycle test data as follows

Total time one cycle	Effective time one cycle	Duty Cycle	AV Factor(dB)
100	14.56	0.15	-16.48

Note: Effective time one cycle=0.23*42+0.49*10=14.56

Duty Cycle= Effective time one cycle/ Total time one cycle=0.15

The actually cycle of EUT is 100.32ms

Test Plot

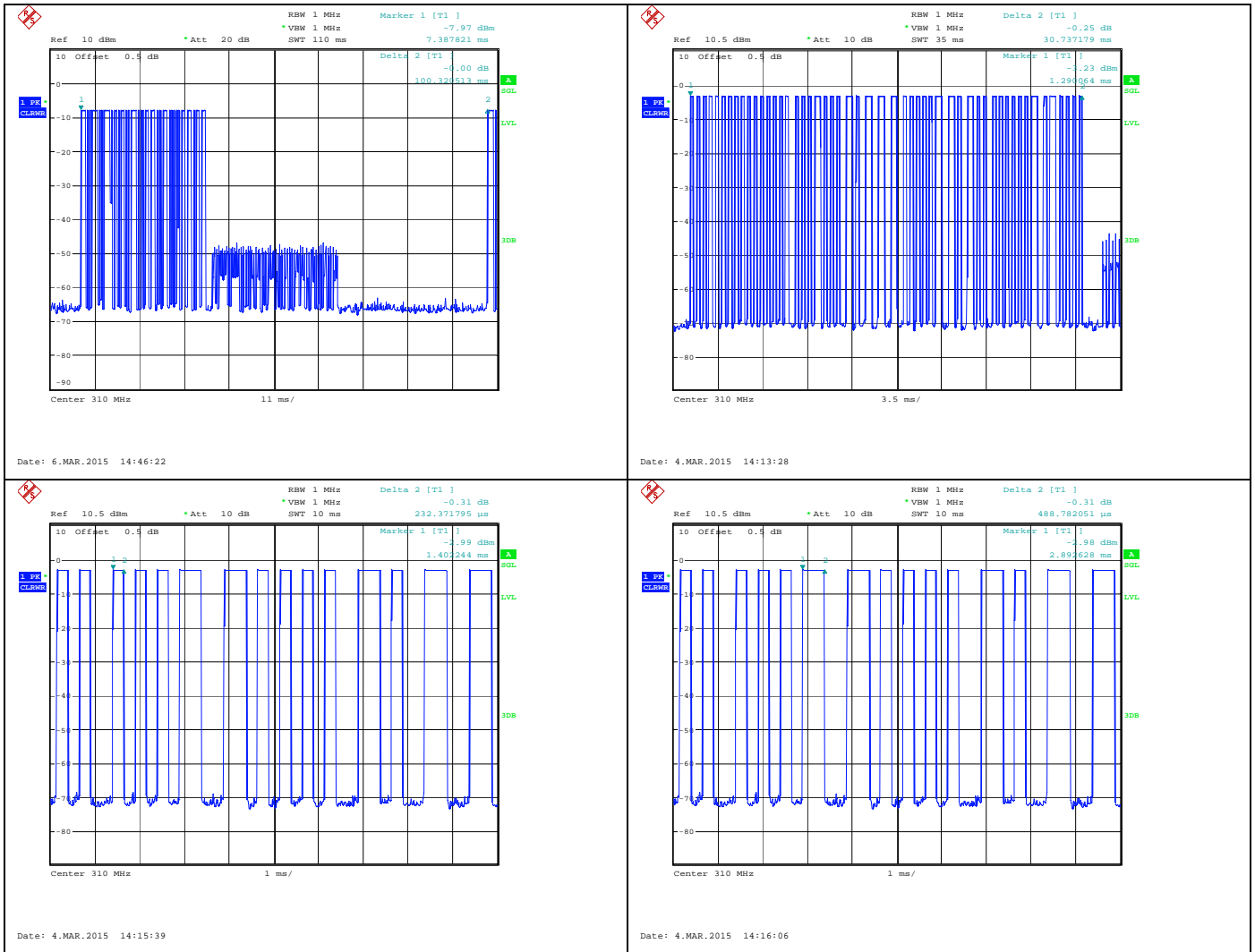

For 315MHz:

A Fundamental Radiated Emission

Frequency (MHz)	Emission Level@3m (dB μ V/m)	Antenna Polarity	Limit@3m (dB μ V/m)	Remark
315	83.14	H	95.62	Peak
315	82.71	V	95.62	Peak

Frequency (MHz)	Peak Emission Level@3m (dB μ V/m)	AV Factor (dB)	AV Emission Level@3m (dB μ V/m)	Antenna Polarity	Limit@3m (dB μ V/m)	Remark
315	83.14	-16.48	66.66	H	75.62	AV
315	82.71	-16.48	66.23	V	75.62	AV

B Harmonics and spurious Radiated Emission

Below 1G

Frequency (MHz)	Emission Level@3m (dB μ V/m)	Antenna Polarity	Limit@3m (dB μ V/m)	Remark
256.19	18.04	H	46.00	QP
630.00	53.71	H	55.62	QP
945.00	43.74	H	55.62	QP
256.19	19.66	V	46.00	QP
630.00	52.84	V	55.62	QP
945.00	39.54	V	55.62	QP

Above 1G For FCC

Frequency (MHz)	Peak Emission Level@3m (dB μ V/m)	AV Factor (dB)	AV Emission Level@3m (dB μ V/m)	Antenna Polarity	Limit@3m (dB μ V/m)	Remark
1240.00	42.02	-16.48	25.54	H	54.00	AV
1860.00	39.24	-16.48	22.76	H	55.62	AV
1240.00	40.38	-16.48	23.90	V	54.00	AV
1860.00	37.11	-16.48	20.63	V	55.62	AV

Above 1G For IC

Frequency (MHz)	Peak Emission Level@3m (dBμV/m)	AV Factor (dB)	AV Emission Level@3m (dBμV/m)	Antenna Polarity	Limit@3m (dBμV/m)	Remark
1240.00	42.68	-16.48	26.20	H	54.00	AV
1860.00	39.26	-16.48	22.78	H	55.62	AV
1240.00	41.40	-16.48	24.92	V	54.00	AV
1860.00	38.33	-16.48	21.85	V	55.62	AV

- Note:
- 1) Emission Level=Reading+ Cable loss+ Antenna factor-Amp factor
 - Test Frequency form 9kHz to 5GHz, the emission levels are 20 dB below the limit value, which are not reported. It is deemed to comply with the requirement
 - 3) AV=Average
 - 4) AV Emission level = Peak Emissions level +AV Factor
 - 5) AV Factor = 20 log(Duty Cycle)

Duty cycle test data as follows

Total time one cycle	Effective time one cycle	Duty Cycle	AV Factor(dB)
100	15.17	0.15	-16.48

Note: Effective time one cycle=0.25*40+0.47*11=15.17

Duty Cycle= Effective time one cycle/ Total time one cycle=0.15

The actually cycle of EUT is 100.05ms

Test Plot

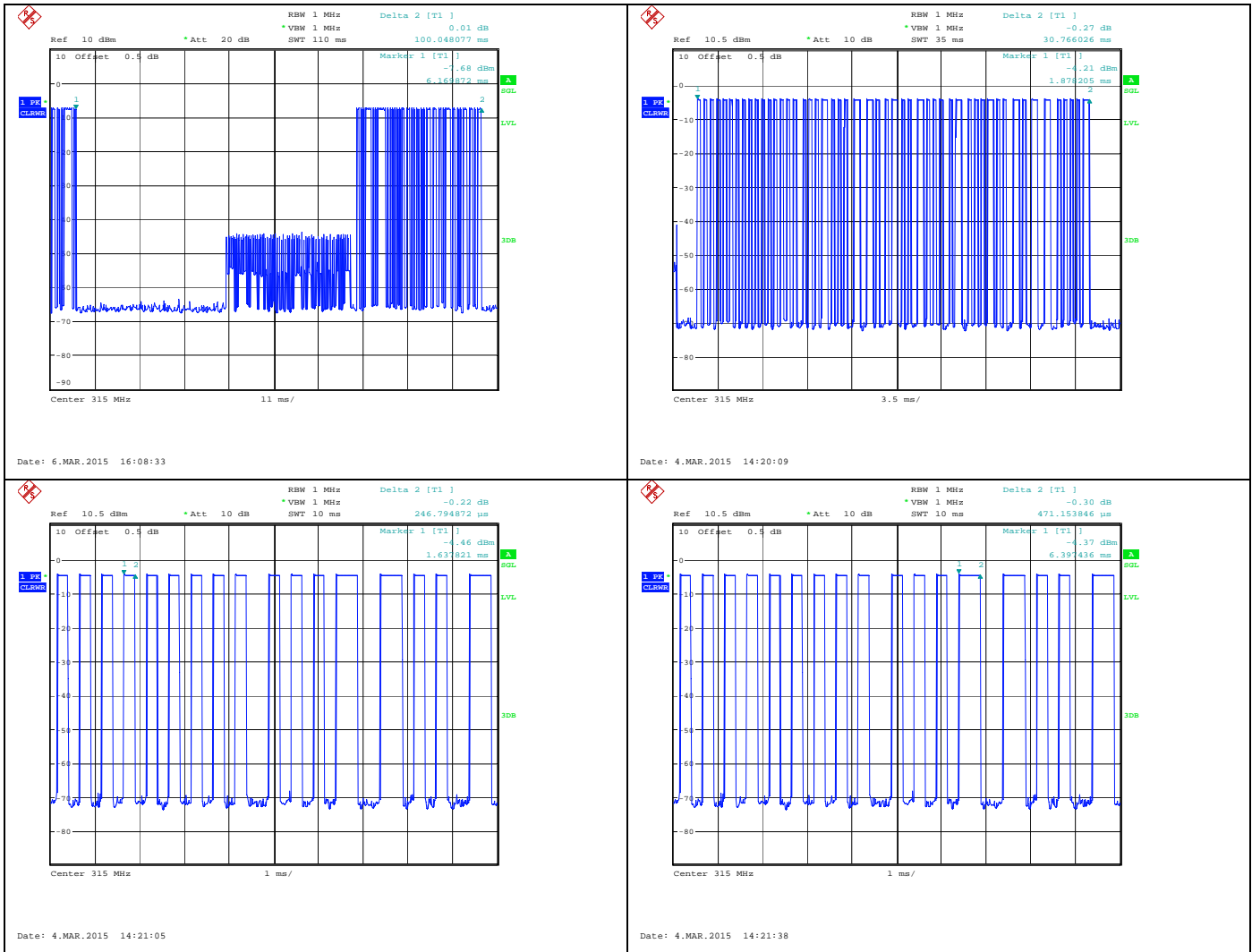

For 390MHz:

A Fundamental Radiated Emission

Frequency (MHz)	Emission Level@3m (dB μ V/m)	Antenna Polarity	Limit@3m (dB μ V/m)	Remark
390	77.19	H	99.24	Peak
390	63.12	V	99.24	Peak

Frequency (MHz)	Peak Emission Level@3m (dB μ V/m)	AV Factor (dB)	AV Emission Level@3m (dB μ V/m)	Antenna Polarity	Limit@3m (dB μ V/m)	Remark
390	77.19	-15.92	61.27	H	79.24	AV
390	63.12	-15.92	47.20	V	79.24	AV

B Harmonics and spurious Radiated Emission

Below 1 G

Frequency (MHz)	Emission Level@3m (dB μ V/m)	Antenna Polarity	Limit@3m (dB μ V/m)	Remark
256.19	17.73	H	46.00	QP
780.00	43.74	H	59.24	QP
256.19	19.29	V	46.00	QP
780.00	45.03	V	59.24	QP

Above 1G For FCC

Frequency (MHz)	Peak Emission Level@3m (dB μ V/m)	AV Factor (dB)	AV Emission Level@3m (dB μ V/m)	Antenna Polarity	Limit@3m (dB μ V/m)	Remark
1170.00	40.11	-15.92	24.19	H	54.00	AV
1950.00	37.24	-15.92	21.32	H	59.24	AV
1170.00	38.65	-15.92	22.73	V	54.00	AV
1950.00	36.09	-15.92	20.17	V	59.24	AV

Above 1G For IC

Frequency (MHz)	Peak Emission Level@3m (dB μ V/m)	AV Factor (dB)	AV Emission Level@3m (dB μ V/m)	Antenna Polarity	Limit@3m (dB μ V/m)	Remark
1170.00	41.69	-15.92	25.77	H	54.00	AV
1950.00	38.72	-15.92	22.80	H	59.24	AV
1170.00	37.51	-15.92	21.59	V	54.00	AV
1950.00	35.88	-15.92	19.96	V	59.24	AV

- Note:
- 1) Emission Level=Reading+ Cable loss+ Antenna factor-Amp factor
Test Frequency form 9kHz to 5GHz, the emission levels are 20 dB below the limit value, which are not reported. It is deemed to comply with the requirement
 - 3) AV=Average
 - 4) AV Emission level = Peak Emissions level +AV Factor
 - 5) AV Factor = 20 log(Duty Cycle)

Duty cycle test data as follows

Total time one cycle	Effective time one cycle	Duty Cycle	AV Factor(dB)
100	15.94	0.16	-15.92

Note: Effective time one cycle=0.26*44+0.50*9=15.94

Duty Cycle= Effective time one cycle/ Total time one cycle=0.16

The actually cycle of EUT is 100.05ms

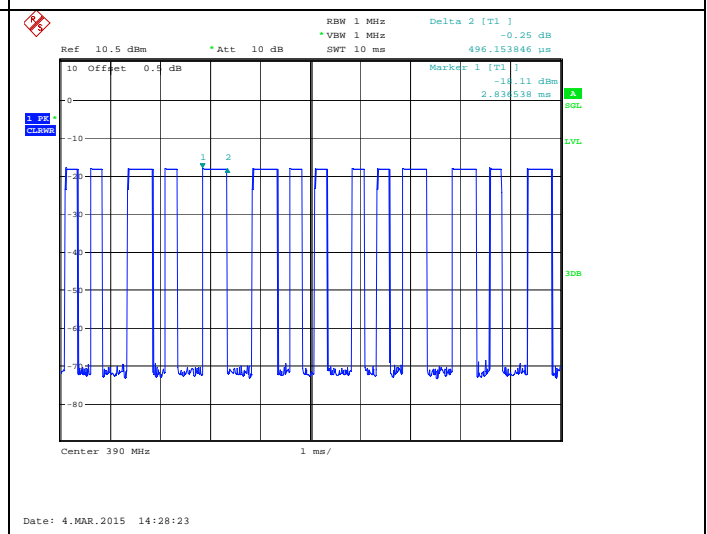
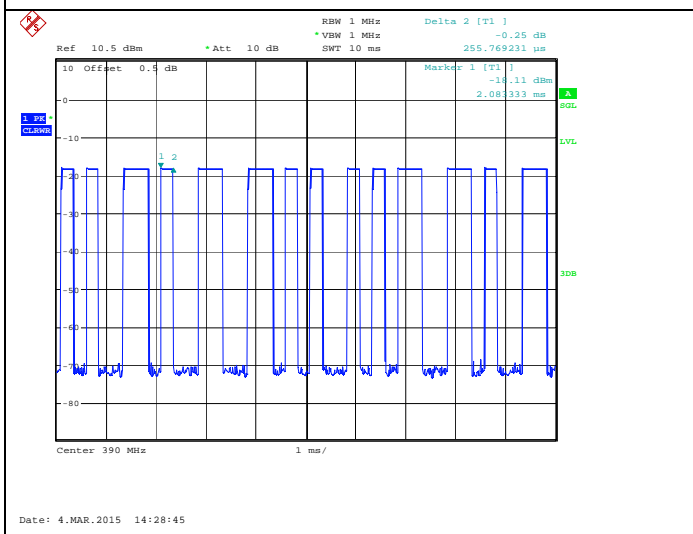
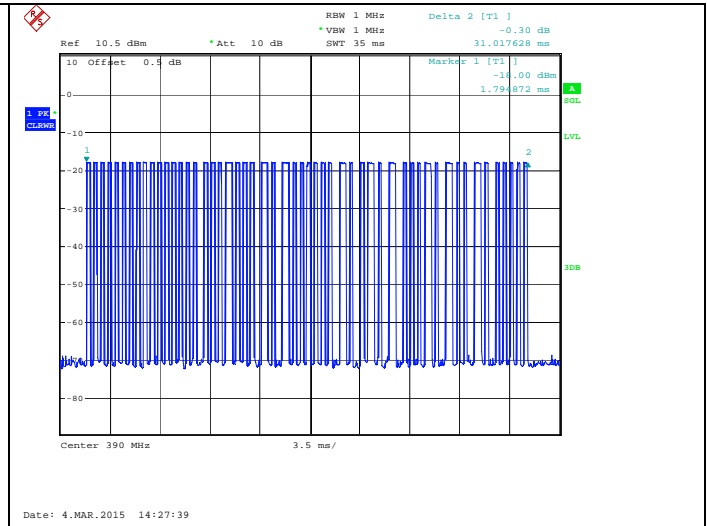
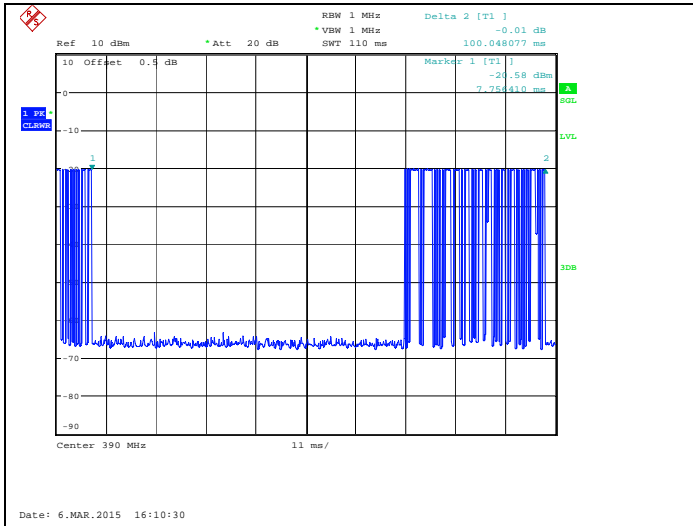

6.4 Bandwidth Test

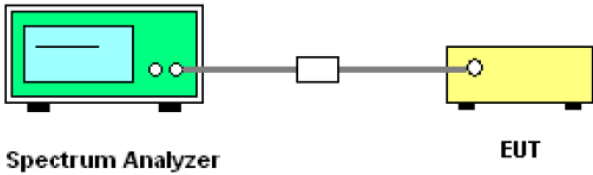
Test Requirement:	FCC Part15 C Section 15.231(c); RSS-210
Test Method:	ANSI C63.4:2009
Receiver setup:	RBW=3 kHz, VBW \geq RBW, Sweep time = Auto.
Limit:	<p>According to 15.231(c),The bandwidth of the emission shall be no wider than 0.25% of the centre frequency for devices operating above 70 MHz and below 900 MHz. For devices operating above 900 MHz, the emission shall be no wider than 0.5% of the centre frequency. Bandwidth is determined at the points 20 dB down from the modulated carrier.</p> <p>According to RSS 210 A1.1.3, the 99% bandwidth shall be no wider than 0.25% of the centre frequency for devices operating between 70 MHz and 900 MHz. For devices operating above 900 MHz, the emission shall be no wider than 0.5% of the centre frequency.</p>
Test Procedure:	<ol style="list-style-type: none"> 1. According to the follow Test-setup, keep the relative position between the artificial antenna and the EUT. 2. Set the EUT to proper test channel. 3. Max hold the radiated emissions, mark the peak power frequency point and the -20dB or 99% upper and lower frequency points . 4. Read 20dB or 99% bandwidth.
Test setup:	 <p>The diagram illustrates the test setup. On the left is a green Spectrum Analyzer with a blue screen and two red indicator lights. A black cable connects it to a white rectangular component, which is then connected to a yellow rectangular EUT (Equipment Under Test) on the right. The labels 'Spectrum Analyzer' and 'EUT' are placed below their respective components.</p>
Test Instruments:	Refer to section 5.9 for details
Test mode:	Refer to section 5.3 for details
Test results:	Passed

Measured data:

Test channel	99% bandwidth (kHz)	20dB bandwidth (kHz)	Limit (kHz)	Results
310M	38.46	18.43	775.0	Pass
315M	40.06	17.63	787.5	Pass
390M	37.66	20.83	975.0	Pass

Test plot for 20dB bandwidth:

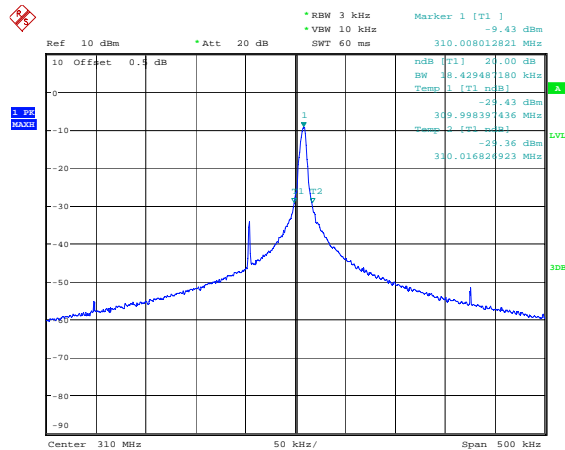

Date: 9.MAR.2015 15:37:04

310M

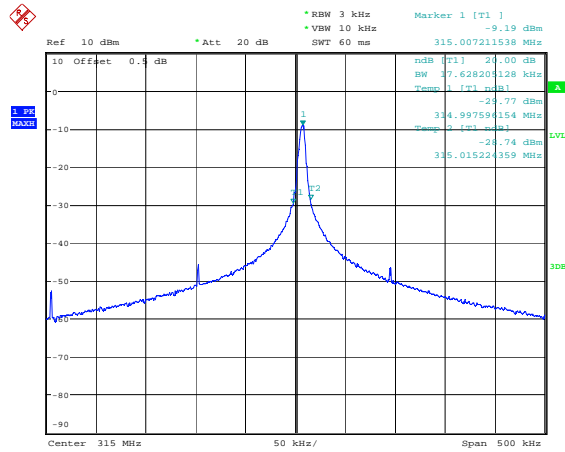

Date: 9.MAR.2015 15:40:00

315M

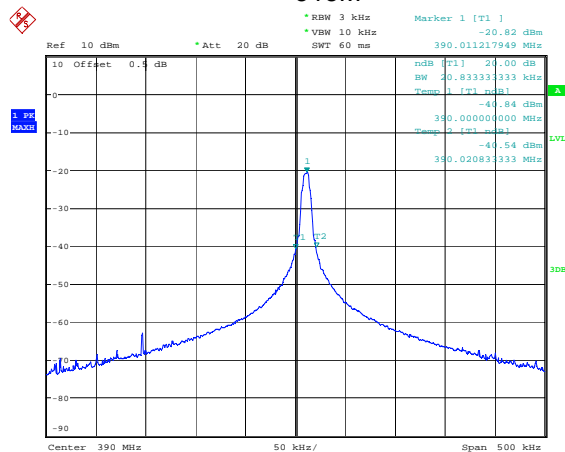

Date: 9.MAR.2015 15:40:48

390M

Test plot for 99% bandwidth:

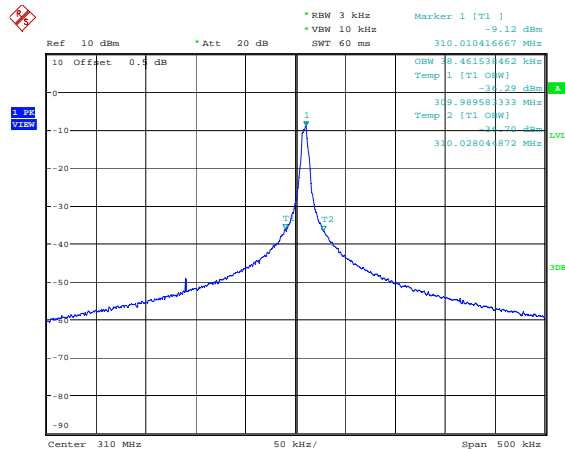

Date: 9.MAR.2015 15:38:30

310M

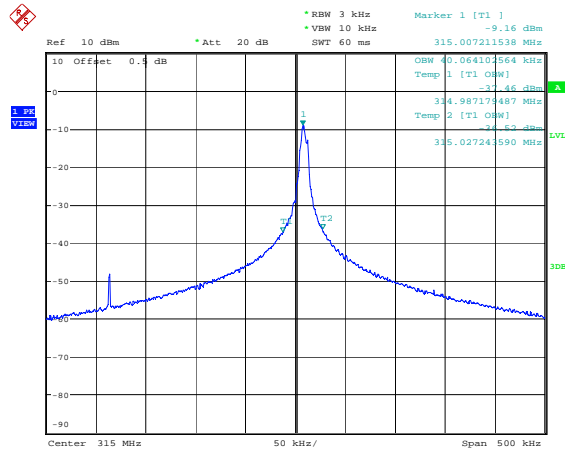

Date: 9.MAR.2015 15:39:06

315M

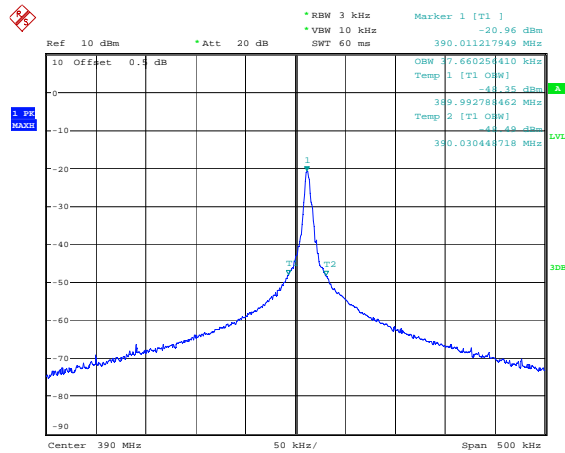

Date: 9.MAR.2015 15:41:26

390M

6.5 Manually Activated Transmitter

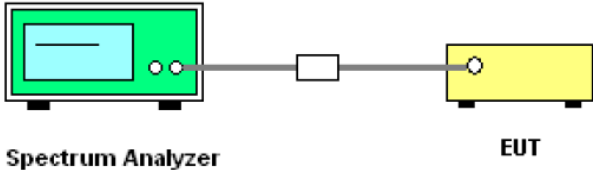
Test Requirement:	FCC Part15 C Section 15.231(a); RSS-210
Test Method:	ANSI C63.4:2009
Receiver setup:	RBW=1 MHz, VBW ≥ RBW
Limit:	A manually operated transmitter shall employ a switch that will automatically deactivate the transmitter within not more than 5 seconds of being released; A transmitter activated automatically shall cease transmission within 5 seconds after activation.
Test Procedure:	<ol style="list-style-type: none"> 1. According to the follow Test-setup, keep the relative position between the artificial antenna and the EUT. 2. Set the EUT to proper test channel. 3. Use the following spectrum analyzer settings: Span = zero span, centered on a channel; RBW = 1 MHz; VBW ≥ RBW; Sweep =5s; Detector function = peak; Trace = max hold. 4. Measure and record the results.
Test setup:	 <p style="text-align: center;">Spectrum Analyzer EUT</p>
Test Instruments:	Refer to section 5.9 for details
Test mode:	Refer to section 5.3 for details
Test results:	Passed

Measured data:

Working Frequency(MHz)	Activate Time(s)	Limit(s)	Result
310	0.775	5	PASS
315	0.775	5	PASS
390	0.727	5	PASS

Test Plot

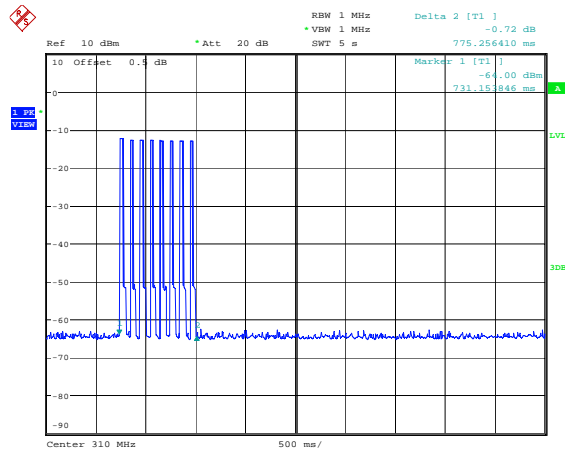

Date: 6.MAR.2015 14:37:17

310M

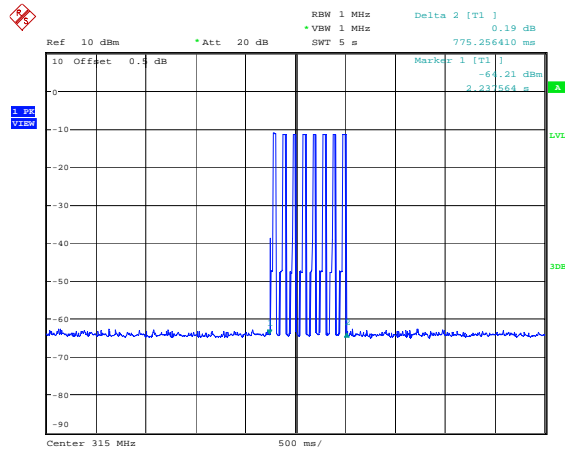

Date: 6.MAR.2015 14:38:30

315M

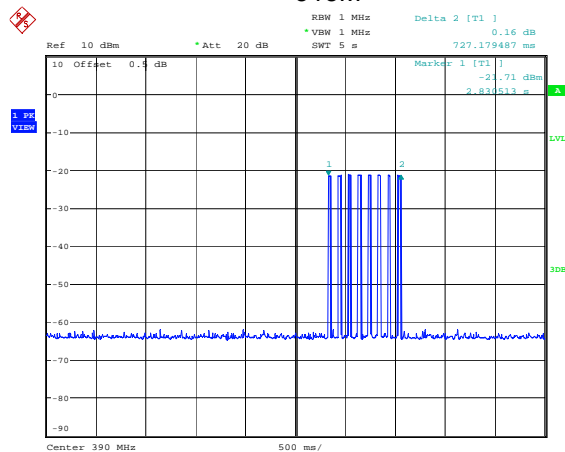

Date: 6.MAR.2015 14:40:41

390M

-----End-----