



ANT,WIFI,2DBI,MONO,POLE,SMA

Sample Qualification Report



Document No.	RTIAN20220310
MPN:	C0289-ANG0011
Prepared by	John
Date	2023/03/27
Revision	01



Revision History

Revision	Description	Date	Approved
01	Initial Release	2023/03/27	Kim Xu

Contents

Revision History 1

Item Description 2

Data Sheet3

TEST DATA VSWR..... 4

TEST DATA GAIN 5

TEST PHOTO 6



Item Description:

ANT,WIFI,2DBI,MONO,POLE,SMA

Electrical Specification

Frequency (MHz)	2.4~2.5GHZ / 5.15~5.85GHZ
VSWR Max	< 3.0
Gain (dBi) Max.	2.0 DBI
Nominal impedance(Ω)	50 OHM
Polarization	VERTICAL

Environmental Data

Environmental conditions	indoor
Operation temperature (°C)	-40 to 260(meet 260 °C wave soldering 3~5s)

Mounting

F-CONN

Mechanical Data

Dimension:	Refer to below drawing
Material:	Brass



Drawing

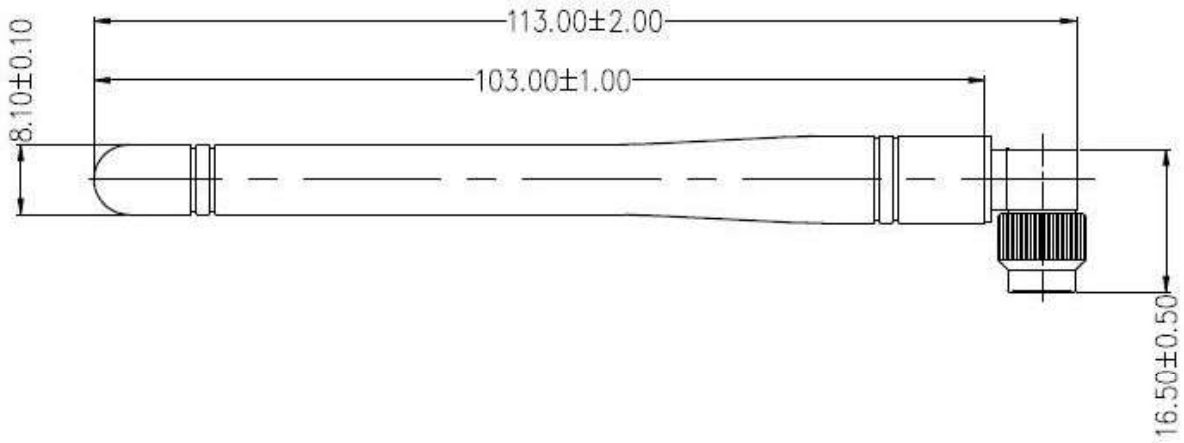

TEST DATA VSWR & RL

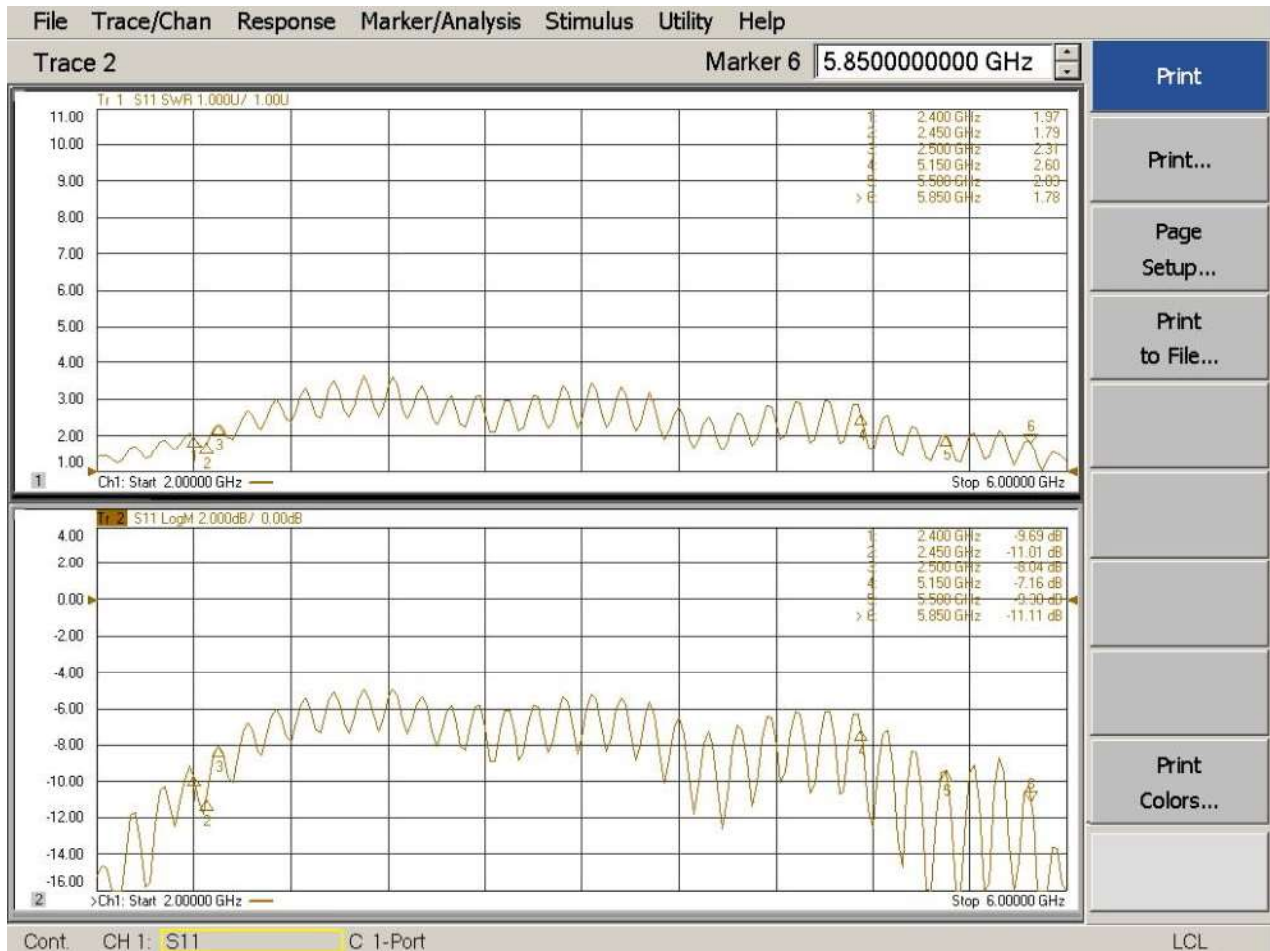



TEST DATA GAIN & EFFICIENCY

Total Attributes	Point Values	Ant. Port Input Pwr. (dBm)	Tot. Rad. Pwr. (dBm)	Peak EIRP (dBm)	Directivity (dBi)	Efficiency (dB)	Efficiency (%)	Gain (dBi)
	Frequency (MHz)							
	2400	0	-1.53916	3.24379	4.78296	-1.53916	70.159	3.24379
	2450	0	-1.95117	2.94107	4.89224	-1.95117	63.8091	2.94107
	2500	0	-2.2047	3.32825	5.53295	-2.2047	60.1908	3.32825
	5150	0	-4.12224	2.5624	6.68464	-4.12224	38.7058	2.5624
	5200	0	-4.08072	2.68353	6.76424	-4.08072	39.0776	2.68353
	5250	0	-3.94582	2.71942	6.66524	-3.94582	40.3105	2.71942
	5300	0	-5.27131	1.01561	6.28692	-5.27131	29.7077	1.01561
	5350	0	-5.00591	1.68885	6.69476	-5.00591	31.5798	1.68885
	5400	0	-4.24182	3.02506	7.26687	-4.24182	37.6546	3.02506
	5470	0	-5.36499	1.47618	6.84117	-5.36499	29.0737	1.47618
	5500	0	-5.20304	1.10524	6.30827	-5.20304	30.1784	1.10524
	5725	0	-4.0797	1.51395	5.59365	-4.0797	39.0868	1.51395
	5850	0	-2.073	3.36916	5.44217	-2.073	62.044	3.36916

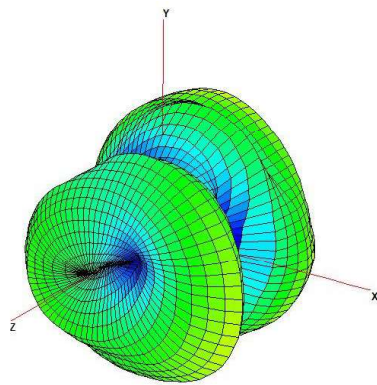

2400MHZ

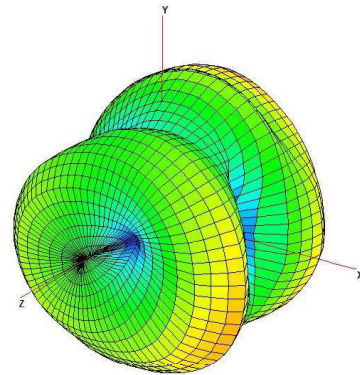

2450MHZ

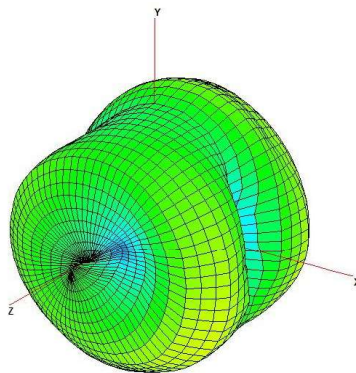

2500MHZ

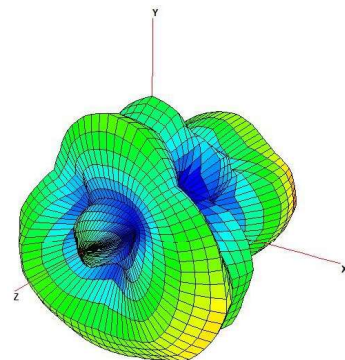

5150MHZ

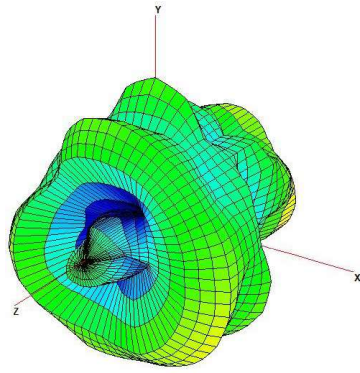

5250MHZ

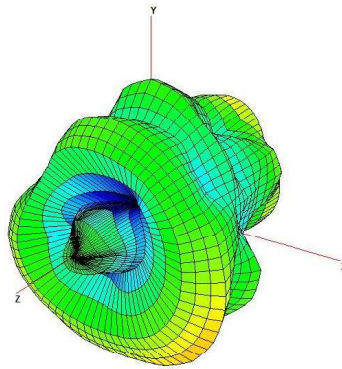

5350MHZ

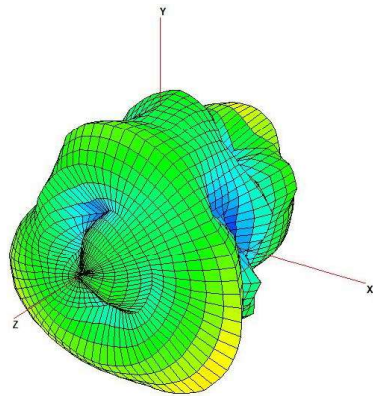

5470MHZ

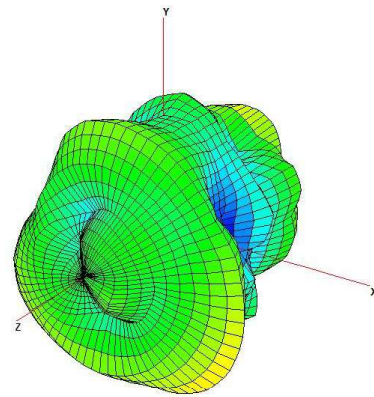

5500MHZ

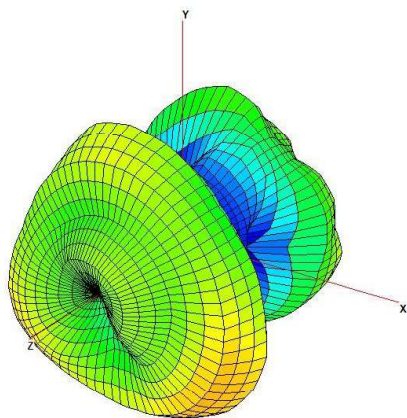

5725MHZ

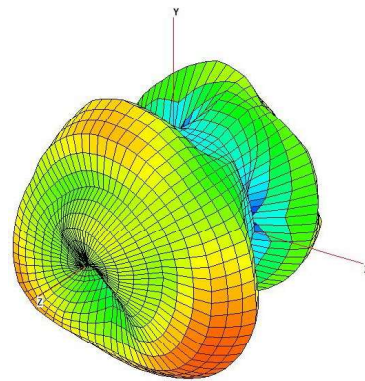

5850MHZ



TEST PHOTO

