

Installation Manual

LED Belt Drive Garage Door Opener

Models B4603TC • B4643TC • B4613TC
B6713TC • B6753TC

FOR RESIDENTIAL USE ONLY

PRE-PROGRAMMED REMOTE
CONTROL INCLUDED

To register your garage door opener to receive updates and offers from Chamberlain, visit chamberlain.registria.com or use the icon below:



1. Take a photo of the camera icon including the points (●).
2. Send it in by texting the photo to 71403 (US).



- Please read this manual and the enclosed safety materials carefully!
- Fasten the manual near the garage door after installation.
- The door **WILL NOT CLOSE** unless the Protector System® is connected and properly aligned.
- Periodic checks of the garage door opener are required to ensure safe operation.
- The model number label is located on the left side panel of your garage door opener.
- This garage door opener is compatible with myQ® and Security+ 2.0® accessories.
- **DO NOT** install on a one-piece door if using devices or features providing unattended close. Unattended devices and features are to be used **ONLY** with sectional doors.

Contents

Preparation	3
Assembly	7
Installation	12
Install the Door Control.....	22
Install the Protector System®.....	24
Connect Power.....	28
Adjustments	30
Battery Backup	33
myQ® App Control	34
Connect With Your Smartphone.....	34
Camera	35
Operation	36
Using your Garage Door Opener.....	36
Motion Detecting Control Panel.....	37
Remote Control and Keyless Entry.....	38
HomeLink®.....	38
Erase the Memory.....	39
To Open the Door Manually.....	39
Maintenance	40
Troubleshooting	41
Warranty	43
Automatic Garage Door Opener Safety & Maintenance Guide	44
Repair Parts	46
Rail Assembly Parts.....	46
Installation Parts.....	46
Model B4603TC.....	47
Model B4613TC.....	48
Model B4643TC.....	49
Models B6713TC, and B6753TC.....	50

Safety Symbol and Signal Word Review

This garage door opener has been designed and tested to offer safe service provided it is installed, operated, maintained and tested in strict accordance with the instructions and warnings contained in this manual.



Mechanical



Electrical

When you see these Safety Symbols and Signal Words on the following pages, they will alert you to the possibility of **serious injury or death** if you do not comply with the warnings that accompany them. The hazard may come from something mechanical or from electric shock. Read the warnings carefully.



When you see this Signal Word on the following pages, it will alert you to the possibility of damage to your garage door and/or the garage door opener if you do not comply with the cautionary statements that accompany it. Read them carefully.



WARNING: This product can expose you to chemicals including lead, which are known to the State of California to cause cancer or birth defects or other reproductive harm. For more information go to www.P65Warnings.ca.gov

Unattended Operation

The Timer-to-Close (TTC) feature, and the myQ® App are examples of unattended close and are to be used ONLY with sectional doors. Any device or feature that allows the door to close without being in the line of sight of the door is considered unattended close. The Timer-to-Close (TTC) feature, the myQ® App, and any other myQ® devices are to be used ONLY with sectional doors.

The images throughout this manual are for reference only and your product may look different.

Preparation

Check the Door

To prevent possible SERIOUS INJURY or DEATH:

- ALWAYS call a trained door systems technician if garage door binds, sticks, or is out of balance. An unbalanced garage door may NOT reverse when required.
- NEVER try to loosen, move or adjust garage door, door springs, cables, pulleys, brackets or their hardware, ALL of which are under EXTREME tension.
- Disable ALL locks and remove ALL ropes connected to garage door BEFORE installation and operating garage door opener to avoid entanglement.
- DO NOT install on a one-piece door if using devices or features providing unattended close. Unattended devices and features are to be used ONLY with sectional doors.

CAUTION

To prevent damage to garage door and opener:

- ALWAYS disable locks BEFORE installing and operating the opener.
- ONLY operate garage door opener at 120V, 60 Hz to avoid malfunction and damage.

Before you begin:

1. Disable locks and remove any ropes connected to the garage door.
2. Lift the door halfway up. Release the door. If balanced, it should stay in place, supported entirely by its springs.
3. Raise and lower the door to check for binding or sticking. If your door binds, sticks, or is out of balance, call a trained door systems technician.
4. Check the seal on the bottom of the door. Any gap between the floor and the bottom of the door must not exceed 1/4" (6 mm). Otherwise, the safety reversal system may not work properly.
5. The opener should be installed above the center of the door. If there is a torsion spring or center bearing plate in the way of the header bracket, it may be installed within 4 feet (1.2 m) to the left or right of the door center. See page 15.

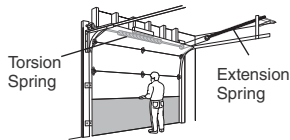

Before You Connect with Your Smartphone

Monitor and control your garage door from anywhere using the myQ® App. You will need a router with Wi-Fi® and a smartphone or other mobile device. Make sure your mobile device is connected to your Wi-Fi® network. Hold your mobile device in the place where your garage door opener will be installed and check the Wi-Fi® signal strength.



Check Signal Strength. If you see:



Wi-Fi signal is strong. You're all set!
Install your new garage door opener.



Wi-Fi signal is weak.
The garage door opener will likely connect to your Wi-Fi network. If not, try one of the options below.



No Wi-Fi signal. Try one of the following:

- Move your router closer to the garage door opener to minimize interference from walls and other objects
- Buy a Wi-Fi range extender

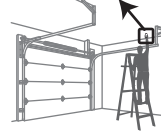

Visit support.chamberlaingroup.com for more details.

See myQ® App Control page 36 to connect your garage door opener to your Wi-Fi® network.

Preparation

Tools Needed

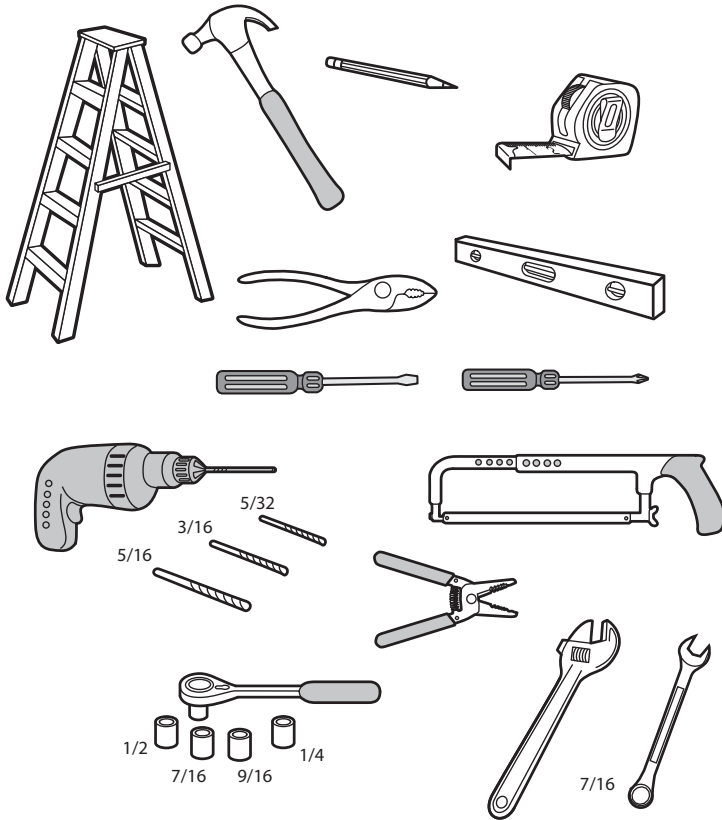

Additional Items You May Need:

Survey your garage area to see if you will need any of the following items:

- **(2) 2X4 Pieces of wood** : May be used to fasten the header bracket to the structural supports. Also used to position the garage door opener during installation and for testing the safety reversing sensors.
- **Support bracket and fastening hardware**: Must be used if you have a finished ceiling in your garage.

Support brackets

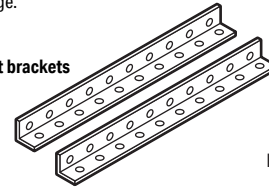

Hanging brackets

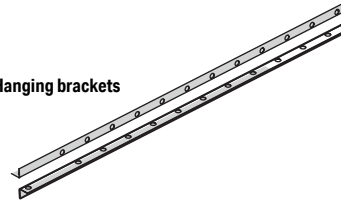

- **Extension brackets (Model 041A5281-1) or wood blocks**: Depending upon garage construction, extension brackets or wood blocks may be needed to install the safety reversing sensor.

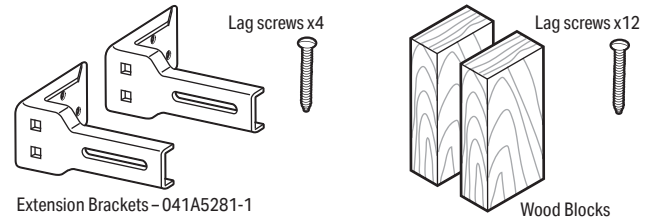

- **Fastening hardware**: Alternate floor mounting of the safety reversing sensor will require hardware not provided.
- **Door reinforcement**: Required if you have a light weight steel, aluminum, fiberglass or glass panel door.
- **Rail extension kit**: Required if your garage door is more than 7 feet (2.13 m) high.

Preparation

Carton Inventory

Save the carton and packing material until the installation and adjustment is complete. Instructions for the accessories will be attached to the accessory and are not included in this manual. The images throughout this manual are for reference only and your product may look different.

1. Header bracket
2. Pulley
3. Door bracket
4. Curved door arm
5. Straight door arm
(Packaged inside front rail section)
6. Trolley
7. Emergency release rope and handle
8. Rail (1 front and 4 center sections)
9. Garage door opener (motor unit)
10. Sprocket cover and screws
11. "U" bracket
12. Belt
13. **The Protector System®**
Safety reversing sensors with 2 conductor white and white/black wire attached: sending sensor (1), receiving sensor (1), and safety sensor brackets (2)
14. Battery Backup - Models B4613TC, B6713TC, and B6753TC
15. Remote control (2)
16. Motion-Detecting Control Panel
17. White and red/white wire
18. Installation manual and all warning labels

See Hardware page 8.

Go to chamberlain.com for replacement or additional accessories:

3-button remote control model 953EV-P2

Wireless keypad model 940EV-P2

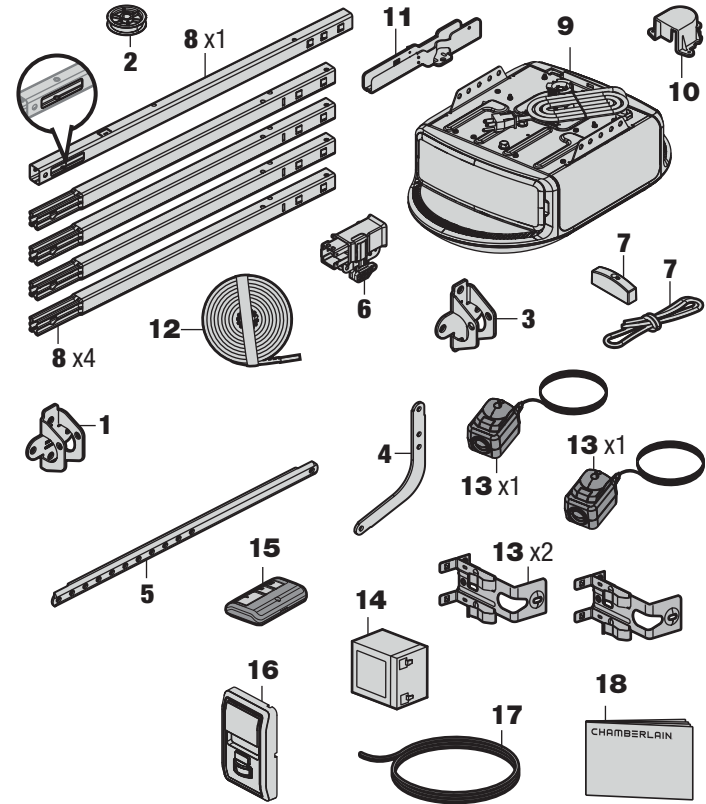

Preparation

Hardware

ASSEMBLY

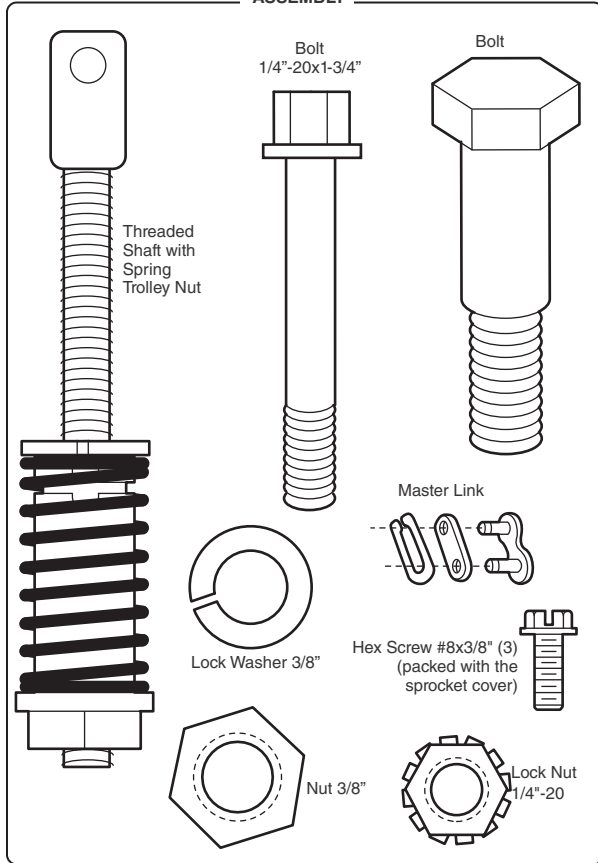

INSTALLATION

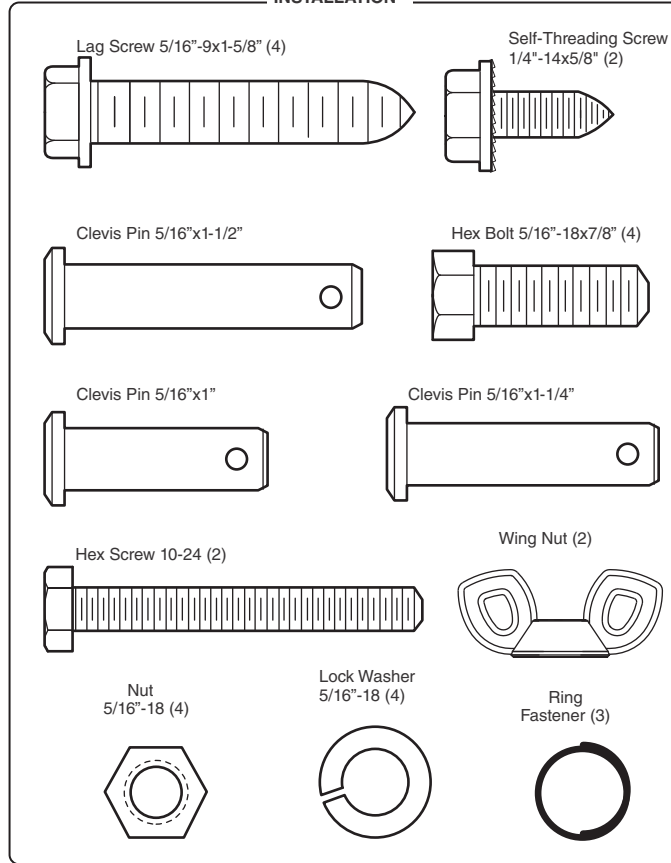

DOOR CONTROL

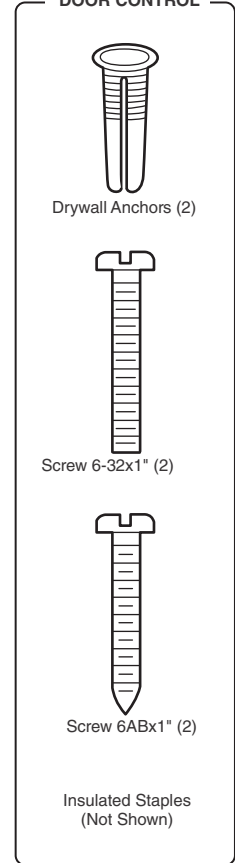

Assembly

STEP 1 Assemble the Rail and Install the Trolley

CAUTION

To prevent INJURY from pinching, keep hands and fingers away from the joints while assembling the rail.

To avoid installation difficulties, do not run the garage door opener until instructed to do so.

The front rail has a cut out "window" at the door end. The rail tab MUST be on top of the rail when assembled.

1. Remove the straight door arm and hanging bracket packaged inside the front rail and set aside for Installation Step 5 and 9. **NOTE:** To prevent INJURY while unpacking the rail carefully remove the straight door arm stored within the rail section.
2. Align the rail sections on a flat surface as shown and slide the tapered ends into the larger ones. Tabs along the side will lock into place.
3. Place the motor unit on packing material to protect the cover, and rest the back end of the rail on top. For convenience, put a support under the front end of the rail.
4. As a temporary stop, insert a screwdriver into the hole in the second rail section from the motor unit, as shown.
5. Check to be sure there are 4 plastic wear pads inside the inner trolley. If they became loose during shipping, check all packing material. Snap them back into position as shown.
6. Slide the trolley assembly toward the screwdriver as shown.
7. Slide the rail onto the "U" bracket, until it reaches all the stops on the top and sides of the "U" bracket.

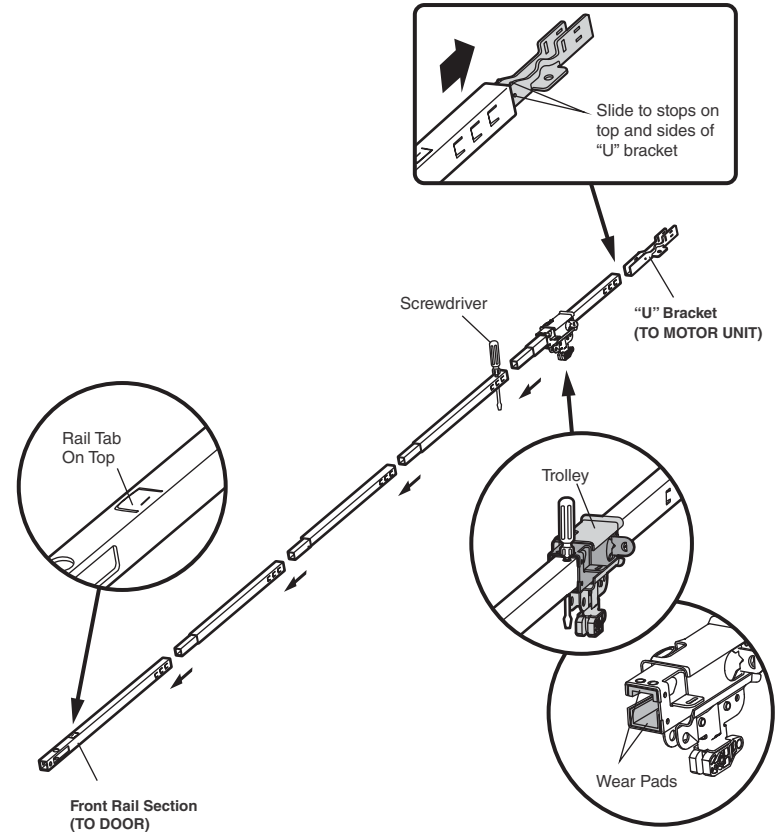

Assembly

STEP 2 Fasten the Rail to the Motor Unit

CAUTION

To avoid **SERIOUS** damage to garage door opener, use **ONLY** those bolts/fasteners mounted in the top of the opener.

1. Insert a 1/4"-20 x 1-3/4" bolt into the cover protection bolt hole on the back end of the rail as shown. Tighten securely with a 1/4"-20 lock nut. **DO NOT** overtighten.
2. Remove the bolts from the top of the motor unit.
3. Use the carton to support the front end of the rail.
4. Place the "U" bracket, flat side down onto the motor unit and align the bracket holes with the bolt holes.
5. Fasten the "U" bracket with the previously removed bolts; **DO NOT** use any power tools. The use of power tools may permanently damage the garage door opener.

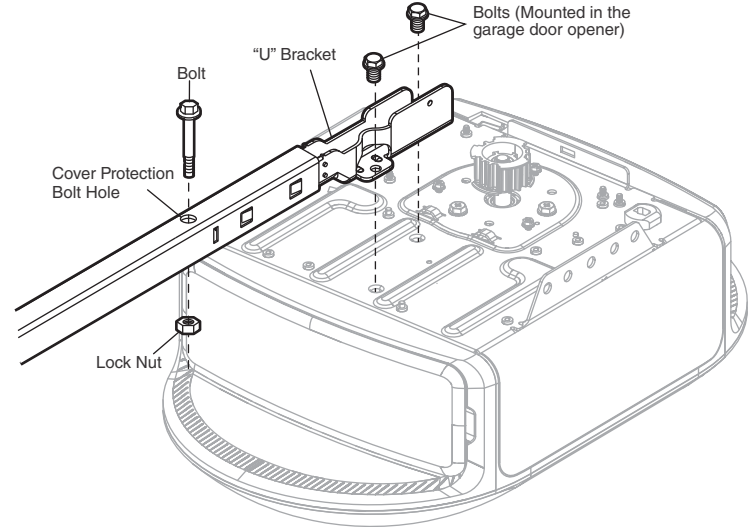
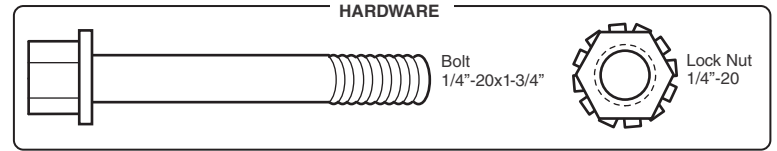

Assembly

STEP 3 Install the Idler Pulley

1. Lay the belt beside the rail, as shown. Grasp the end with the hooked trolley connector and pass approximately 12" (30 cm) of belt through the window. Keep the ribbed side toward the rail, and allow it to hang until Assembly Step 4.
2. Remove the tape from the idler pulley. The inside center should be pre-greased. If dry, regrease to ensure proper operation.
3. Place the idler pulley into the window as shown.
4. Insert the idler bolt from the top through the rail and pulley. Tighten with a 3/8" lock washer and nut underneath the rail until the lock washer is compressed.
5. Rotate the pulley to be sure it spins freely.
6. Locate the rail tab. The rail tab is between the idler bolt and the trolley in the front rail section. Use a flathead screwdriver and lift the rail tab until the tab is vertical (90°).

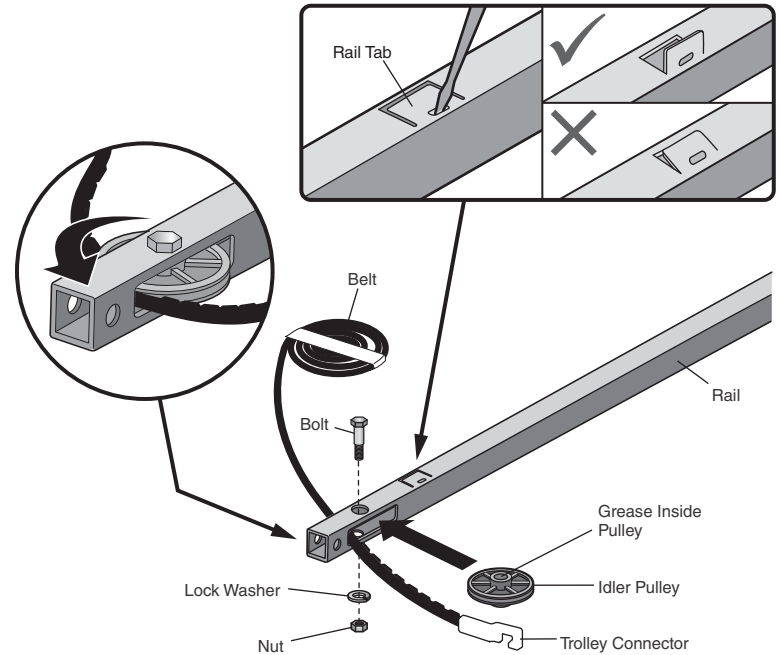
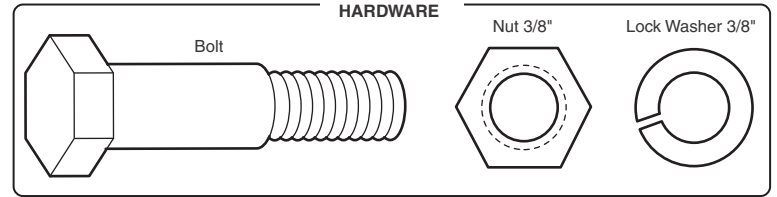

Assembly

STEP 4 Install the Belt

1. Pull the belt around the idler pulley and toward the trolley. The ribbed side must contact the pulley.
2. Hook the trolley connector into the retaining slot on the trolley as shown (Figure 1).
3. With the trolley against the screwdriver, dispense the remainder of the belt along the rail length toward the motor unit and around the sprocket (Figure 2). The sprocket teeth must engage the belt.
4. Check to make sure the belt is not twisted. Connect the trolley threaded shaft with the master link (Figure 3).
- a. Push pins of master link bar through holes in end of belt and trolley threaded shaft.
- b. Push master link cap over pins and past pin notches.
- c. Slide the closed end of the clip-on spring over one of the pins. Push the open end of the clip-on spring onto the other pin.
5. Remove the spring trolley nut from the threaded shaft.
6. Insert the trolley threaded shaft through the hole in the trolley.

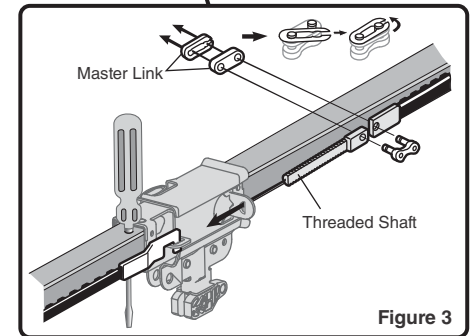
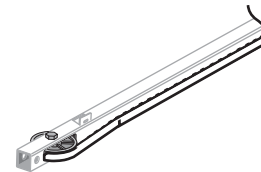
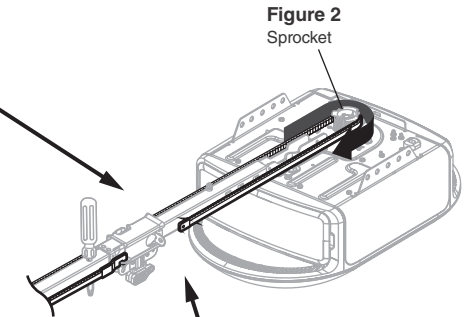
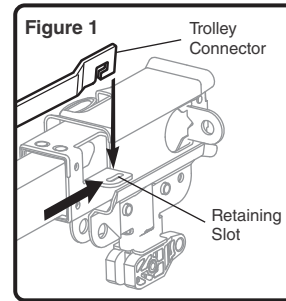
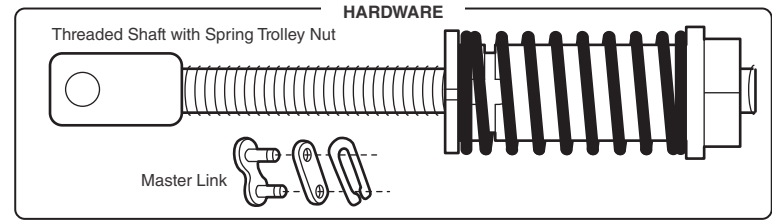

Assembly

STEP 5 Tighten the Belt

1. By hand, thread the spring trolley nut on the threaded shaft until it is finger tight against the trolley. Do not use any tools. Remove the screwdriver.
2. Insert a flathead screwdriver tip into one of the nut ring slots and brace it firmly against the trolley.
3. Tighten the spring trolley nut with an adjustable wrench or a 7/16" open end wrench about a quarter turn until the spring releases and snaps the nut ring against the trolley. This sets the spring to optimum belt tension.

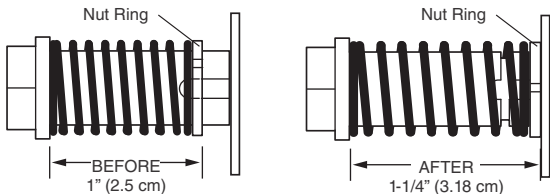
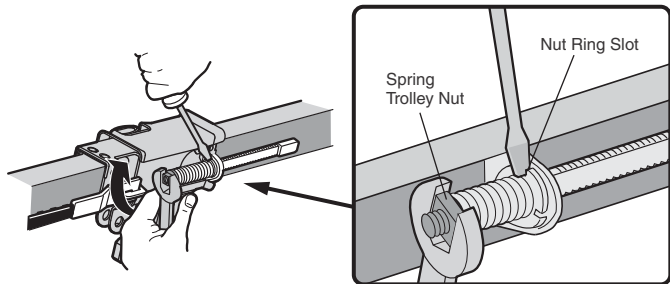

STEP 6 Install the Sprocket Cover

To avoid possible **SERIOUS INJURY** to finger from moving garage door opener:

- ALWAYS keep hand clear of sprocket while operating opener.
- Securely attach sprocket cover **BEFORE** operating.

1. Position the sprocket cover over the sprocket as shown and fasten to the mounting plate with #8x3/8" hex screws provided.

You have now finished assembling your garage door opener. Please read the following warnings before proceeding to the installation section.

HARDWARE



Hex Screw #8x3/8"
(Packed with the sprocket cover)

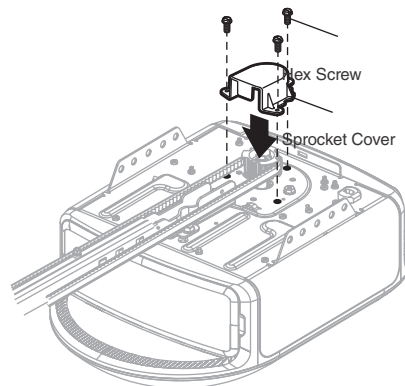

IMPORTANT INSTALLATION INSTRUCTIONS



To reduce the risk of SEVERE INJURY or DEATH:

1. READ AND FOLLOW ALL INSTALLATION WARNINGS AND INSTRUCTIONS.
2. Install garage door opener ONLY on properly balanced and lubricated garage door. An improperly balanced door may NOT reverse when required and could result in SEVERE INJURY or DEATH.
3. ALL repairs to cables, spring assemblies and other hardware MUST be made by a trained door systems technician BEFORE installing opener.
4. Disable ALL locks and remove ALL ropes connected to garage door BEFORE installing opener to avoid entanglement.
5. Where possible, install the door opener 7 feet (2.13 m) or more above the floor.
6. Mount the emergency release within reach, but at least 6 feet (1.83 m) above the floor and avoiding contact with vehicles to avoid accidental release.
7. NEVER connect garage door opener to power source until instructed to do so.
8. NEVER wear watches, rings or loose clothing while installing or servicing opener. They could be caught in garage door or opener mechanisms.
9. Install wall-mounted garage door control:
 - within sight of the garage door.
 - out of reach of small children at a minimum height of 5 feet (1.5 m) above floors, landings, steps or any other adjacent walking surface.
 - away from ALL moving parts of the door.
10. Place entrapment warning label on wall next to garage door control in a prominent location.
11. Place emergency release/safety reverse test label in plain view on inside of garage door.
12. Upon completion of installation, test safety reversal system. Door MUST reverse on contact with a 1-1/2" (3.8 cm) high object (or a 2x4 laid flat) on the floor.
13. DO NOT install on a one-piece door if using devices or features providing unattended close. Unattended devices and features are to be used ONLY with sectional doors.

14. SAVE THESE INSTRUCTIONS.

Installation

STEP 1 Determine the Header Bracket Location

To prevent possible SERIOUS INJURY or DEATH:

- Header bracket **MUST** be RIGIDLY fastened to structural support on header wall or ceiling, otherwise garage door might NOT reverse when required. **DO NOT** install header bracket over drywall.
- Concrete anchors **MUST** be used if mounting header bracket or 2x4 into masonry.
- **NEVER** try to loosen, move or adjust garage door, springs, cables, pulleys, brackets, or their hardware, ALL of which are under EXTREME tension.
- **ALWAYS** call a trained door systems technician if garage door binds, sticks, or is out of balance. An unbalanced garage door might NOT reverse when required.

Installation procedures vary according to garage door types. Follow the instructions which apply to your door.

1. Close the door and mark the inside vertical centerline of the garage door.
2. Extend the line onto the header wall above the door. You can fasten the header bracket within 4 feet (1.22 m) of the left or right of the door center only if a torsion spring or center bearing plate is in the way; or you can attach it to the ceiling (see page 16) when clearance is minimal. (It may be mounted on the wall upside down, if necessary, to gain approximately 1/2" (1 cm). If you need to install the header bracket on a 2x4 (on wall or ceiling), use lag screws (not provided) to securely fasten the 2x4 to structural supports as shown here and on page 16.
3. Open your door to the highest point of travel as shown. Draw an intersecting horizontal line on the header wall 2" (5 cm) above the high point:
 - 2" (5 cm) above the high point for sectional door and one-piece door with track.
 - 8" (20 cm) above the high point for one-piece door without track.

This height will provide travel clearance for the top edge of the door. **NOTE:** If the total number of inches exceeds the height available in your garage, use the maximum height possible, or refer to page 16 for ceiling installation.

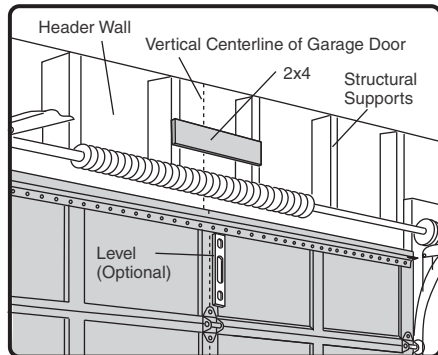

OPTIONAL CEILING MOUNT FOR HEADER BRACKET

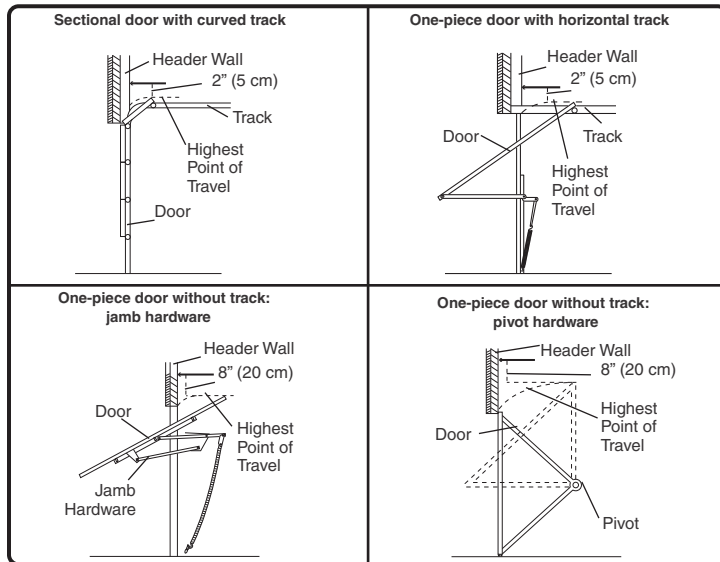
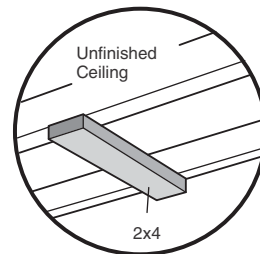

Installation

STEP 2 Install the Header Bracket

You can attach the header bracket either to the wall above the garage door, or to the ceiling. Follow the instructions which will work best for your particular requirements. **Do not install the header bracket over drywall. If installing into masonry, use concrete anchors (not provided).**

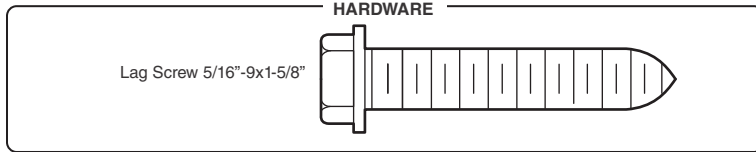

OPTION A - WALL INSTALLATION

1. Center the bracket on the vertical center line with the bottom edge of the bracket on the horizontal line as shown (with the arrow pointing toward the ceiling).
2. Mark the vertical set of bracket holes. Drill 3/16" pilot holes and fasten the bracket securely to a structural support with the hardware provided.

OPTION B - CEILING INSTALLATION

1. Extend the vertical centerline onto the ceiling as shown.
2. Center the bracket on the vertical mark, no more than 6" (15 cm) from the wall. Make sure the arrow is pointing away from the wall. The bracket can be mounted flush against the ceiling when clearance is minimal.
3. Mark the side holes. Drill 3/16" pilot holes and fasten bracket securely to a structural support with the hardware provided.

WALL INSTALLATION

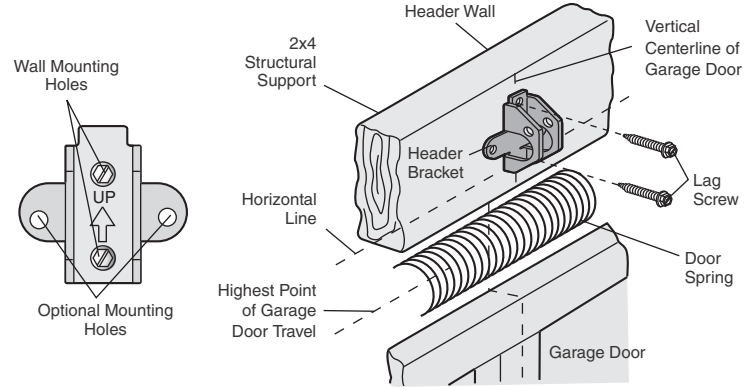

CEILING INSTALLATION

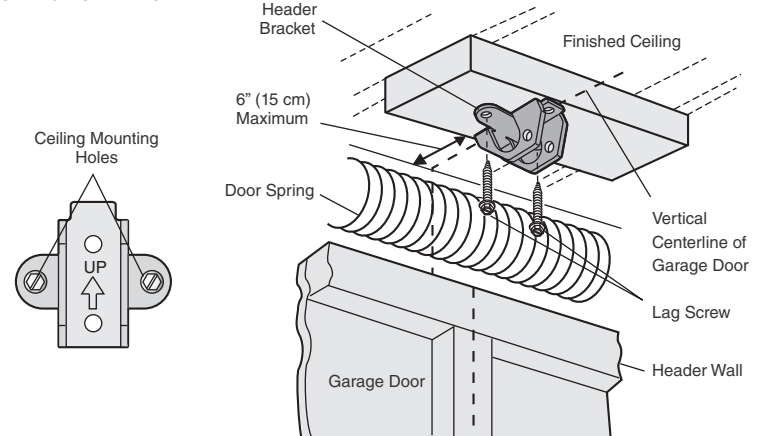

Installation

STEP 3 Attach the Rail to the Header Bracket

1. Position the opener on the garage floor below the header bracket. Use packing material as a protective base.
NOTE: If the door spring is in the way, you will need help. Have someone hold the opener securely on a temporary support to allow the rail to clear the spring.
2. Position the rail bracket against the header bracket.
3. Align the bracket holes and join with a clevis pin as shown.
4. Insert a ring fastener to secure.

HARDWARE

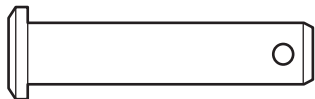

Clevis Pin
5/16" x 1-1/2"



Ring Fastener

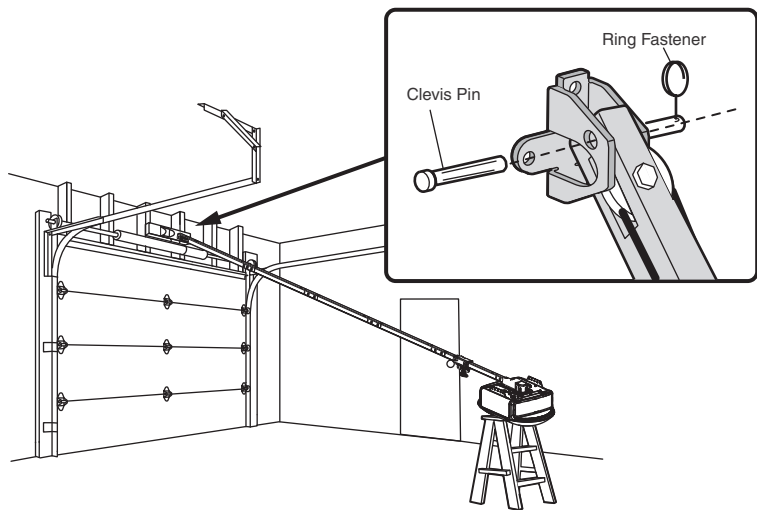

STEP 4 Position the Garage Door Opener

CAUTION

To prevent damage to garage door, rest garage door opener rail on 2x4 placed on top section of door.

1. Remove the packing material and lift the garage door opener onto a ladder.
2. Fully open the door and place a 2x4 (laid flat) under the rail. For one-piece doors without tracks, lay the 2x4 on its side.

NOTE: A 2x4 is ideal for setting the distance between the rail and the door. If the ladder is not tall enough you will need help at this point. If the door hits the trolley when it is raised, pull the trolley release arm down to disconnect the inner and outer trolley. Slide the outer trolley toward the garage door opener. The trolley can remain disconnected until instructed.

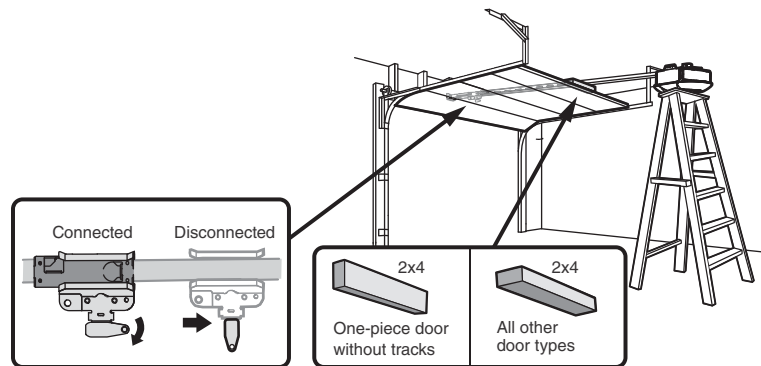

Installation

STEP 5 Hang the Garage Door Opener

To avoid possible **SERIOUS INJURY** from a falling garage door opener, fasten it **SECURELY** to structural supports of the garage. Concrete anchors **MUST** be used if installing **ANY** brackets into masonry.

Hanging the garage door opener will vary depending on your garage. Below are three example installations. Your installation may be different. For **ALL** installations the garage door opener **MUST** be connected to structural supports. The instructions illustrate one of the examples below.

1. On finished ceilings, use the lag screws to attach a support bracket (not provided) to the structural supports before installing the garage door opener.
2. Make sure the garage door opener is aligned with the header bracket. Measure the distance from each side of the garage door opener to the support bracket.
3. Cut both pieces of the hanging bracket (not provided) to required lengths.
4. Attach the end of each hanging bracket to the support bracket with appropriate hardware (not provided).
5. Attach the garage door opener to the hanging brackets with the hex bolts, lock washers, and nuts.
6. Remove the 2x4 and manually close the door. If the door hits the rail, raise the header bracket.

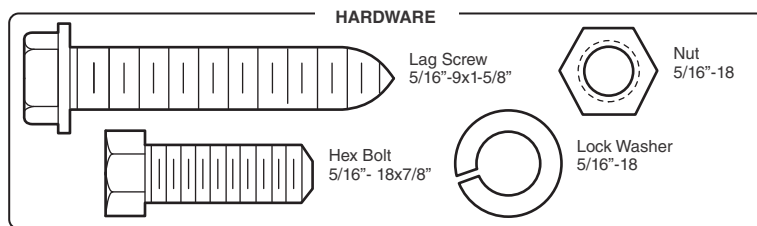

EXAMPLES

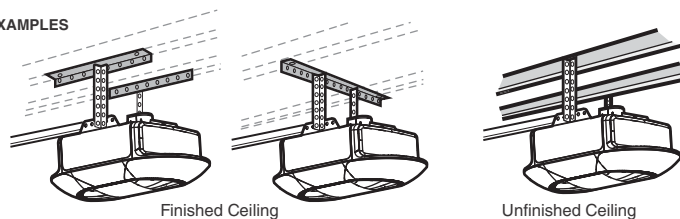

1 Finished Ceiling

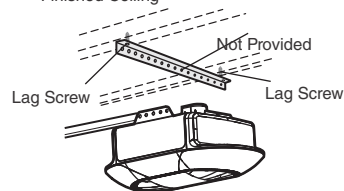

2 Not Provided

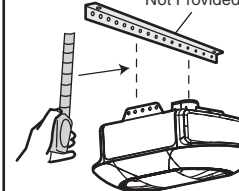

3

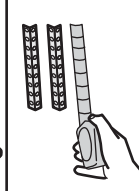

4

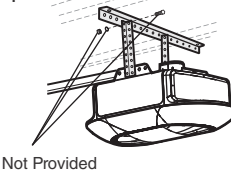

5

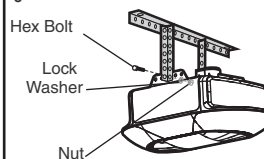

6

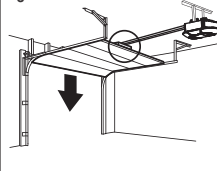

Installation

STEP 6 Attach the Emergency Release Rope and Handle

To prevent possible SERIOUS INJURY or DEATH from a falling garage door:

- If possible, use emergency release handle to disengage trolley ONLY when garage door is CLOSED. Weak or broken springs or unbalanced door could result in an open door falling rapidly and/or unexpectedly.
- NEVER use emergency release handle unless garage doorway is clear of persons and obstructions.
- NEVER use handle to pull door open or closed. If rope knot becomes untied, you could fall.

1. Insert one end of the emergency release rope through the handle. Make sure that "NOTICE" is right side up. Secure with an overhand knot at least 1" (2.5 cm) from the end of the rope to prevent slipping.
2. Insert the other end of the emergency release rope through the hole in the trolley release arm. Mount the emergency release within reach, but at least 6 feet (1.83 m) above floor, avoiding contact with vehicles to prevent accidental release and secure with an overhand knot.

NOTE: If it is necessary to cut the emergency release rope, seal the cut end with a match or lighter to prevent unraveling. Ensure the emergency release rope and handle are above the top of all vehicles to avoid entanglement.

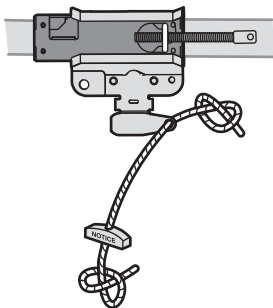

Installation

STEP 7 Install the Door Bracket

CAUTION

Fiberglass, aluminum or light weight steel garage doors **WILL REQUIRE** reinforcement BEFORE installation of door bracket. Contact the garage door manufacturer or installing dealer for opener reinforcement instructions or reinforcement kit. Failure to reinforce the top section as required according to the door manufacturer may void the door warranty.

A horizontal and vertical reinforcement is needed for light weight garage doors (fiberglass, aluminum, steel, doors with glass panel, etc.) (not provided). A horizontal reinforcement brace should be long enough to be secured to two or three vertical supports. A vertical reinforcement brace should cover the height of the top panel. Contact the garage door manufacturer or installing dealer for opener reinforcement instructions or reinforcement kit.

NOTE: Many door reinforcement kits provide for direct attachment of the clevis pin and door arm. In this case you will not need the door bracket; proceed to the next step.

OPTIONA- SECTIONALDOORS

1. Center the door bracket on the previously marked vertical centerline used for the header bracket installation. Note correct UP placement, as stamped inside bracket.
2. Position the top edge of the bracket 2"-4" (5-10 cm) below the top edge of the door, OR directly below any structural support across the top of the door.
3. Mark, drill holes and install as follows, depending on your door's construction.

Metal or light weight doors using a vertical angle iron brace in the door panel support and the door bracket:

- Drill 3/16" fastening holes. Secure the door bracket using the two 1/4"-14x5/8" self-threading screws. (Figure 1)
- Alternately, use two 5/16"-18x2" bolts, lock washers and nuts (not provided). (Figure 2)

Metal, insulated or light weight factory reinforced doors:

- Drill 3/16" fastening holes. Secure the door bracket using the self-threading screws. (Figure 3)

Wood doors:

- Use top and bottom or side to side door bracket holes. Drill 5/16" holes through the door and secure bracket with 5/16"-18x2" carriage bolts, lock washers and nuts (not provided). (Figure 4)

NOTE: The 1/4"-14x5/8" self-threading screws are not intended for use on wood doors.

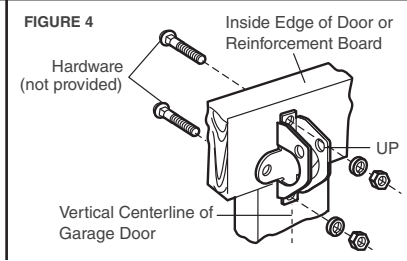
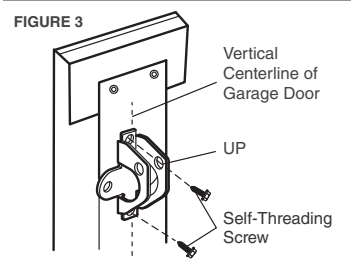
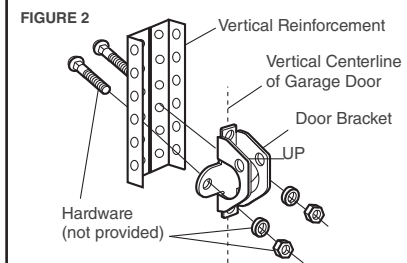
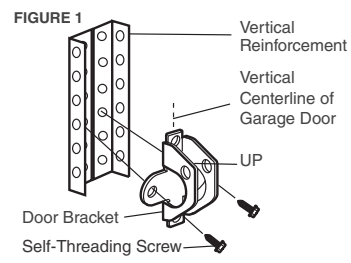
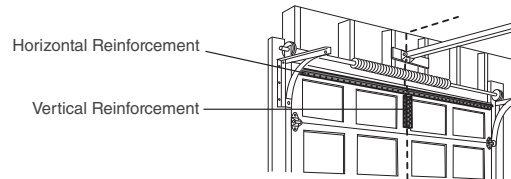
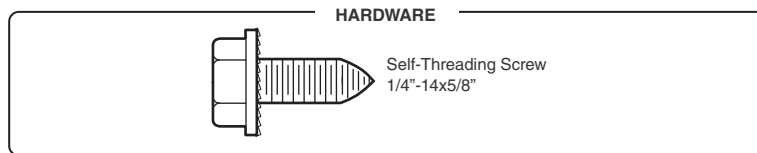

Installation

STEP 7 Install the Door Bracket (continued)

OPTION B- ONE-PIECE DOORS

1. Center the door bracket on the top of the door, in line with the header bracket as shown.
2. Mark either the left and right, or the top and bottom holes.

Metal Doors:

- Drill 3/16" pilot holes and fasten the bracket with the self-threading screws provided.

Wood Doors:

- Drill 5/16" holes and use 5/16"-18x2" carriage bolts, lock washers and nuts (not provided) or 5/16"x1-1/2" lag screws (not provided) depending on your installation needs.

NOTE: The door bracket may be installed on the top edge of the door if required for your installation. (Refer to the dotted line optional placement drawing.)

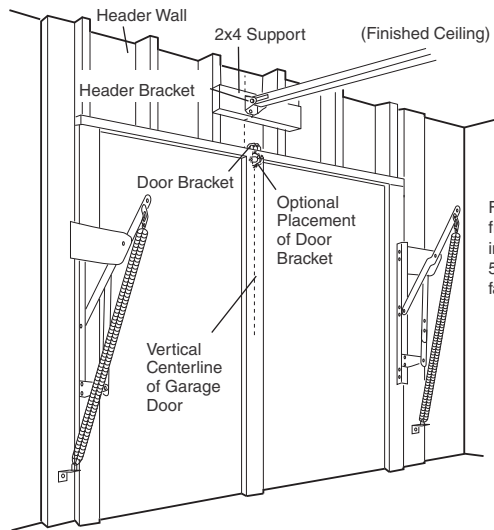

For a door with no exposed framing, or for the optional installation, use lag screws 5/16"x1-1/2" (not provided) to fasten the door bracket.

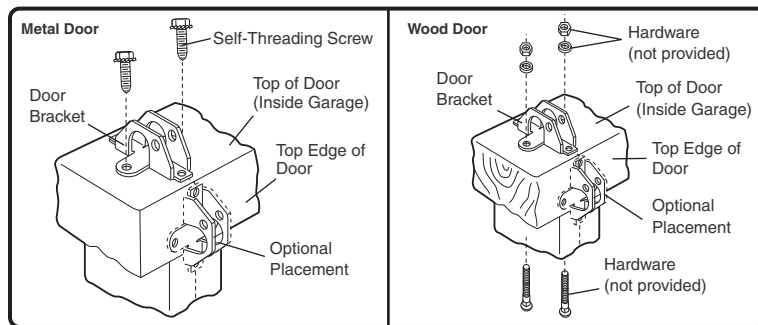

Installation

STEP 8 Connect the Door Arm to the Trolley

Installation will vary according to the garage door type. Follow the instructions which apply to your door.

OPTION A - SECTIONAL DOORS

IMPORTANT: The groove on the straight door arm **MUST** face away from the curved door arm.

1. Close the door. Disconnect the trolley by pulling the emergency release handle.
2. Attach the straight door arm to the outer trolley using the clevis pin. Secure with the ring fastener.
3. Attach the curved door arm to the door bracket using the clevis pin. Secure with the ring fastener.
4. Bring arm sections together. Find two pairs of holes that line up and join sections. Select holes as far apart as possible to increase door arm rigidity and attach using the bolts, nuts, and lock washers.
5. Pull the emergency release handle toward the garage door opener until the trolley release arm is horizontal. The trolley will re-engage automatically when the garage door opener is activated.

NOTE: If the holes in the curved door arm and the straight door arm do not align, reverse the straight door arm, select two holes (as far apart as possible) and attach using bolts, nuts, and lock washers. If the straight door arm is hanging down too far, you may cut 6" (15 cm) from the solid end.

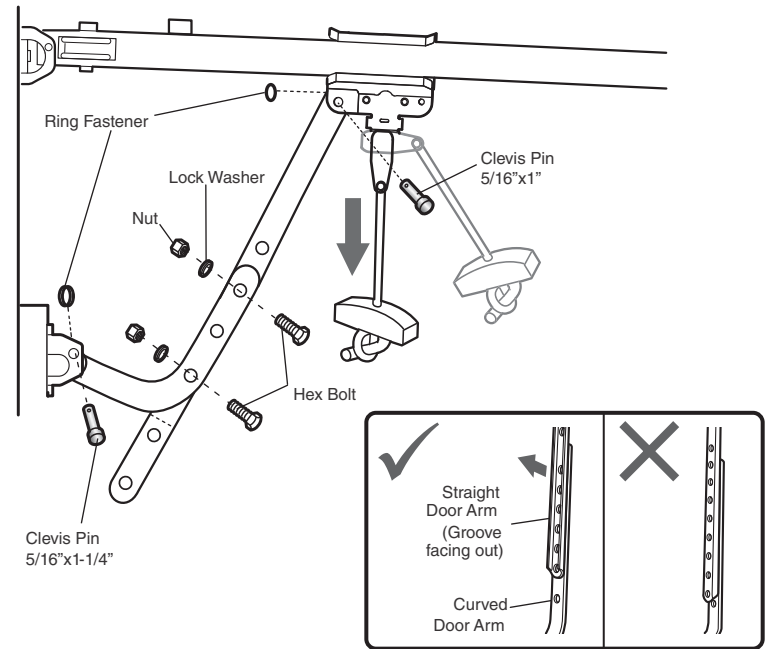
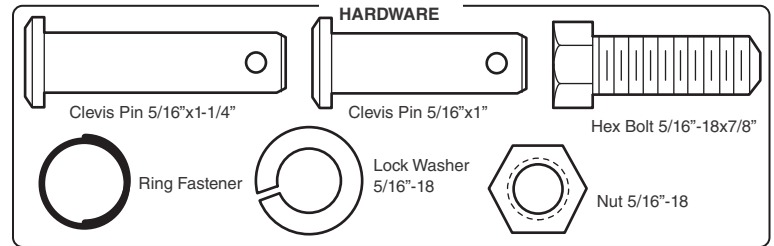

Installation

STEP 8 Connect the Door Arm to the Trolley (continued)

OPTION B- ONE-PIECE DOORS

IMPORTANT: The groove on the straight door arm **MUST** face away from the curved door arm.

1. Close the door. Disconnect the trolley by pulling the emergency release handle.
2. Fasten the straight door arm and the curved door arm together to the longest possible length (with a 2 or 3 hole overlap) using the bolts, nuts, and lock washers.
3. Attach the straight door arm to the door bracket using the clevis pin. Secure with the ring fastener.
4. Attach the curved door arm to the trolley using the clevis pin. Secure with the ring fastener.
5. Pull the emergency release handle toward the garage door opener until the trolley release arm is horizontal.

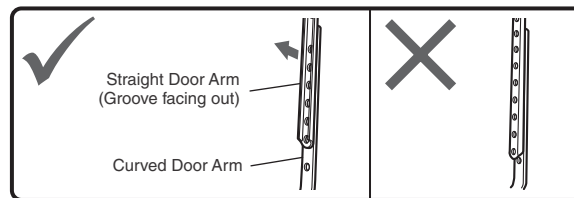
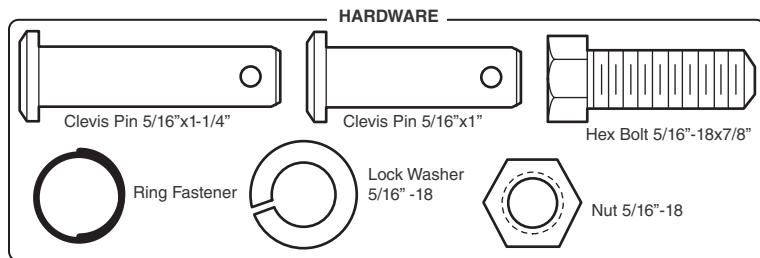

One-Piece Door without Track

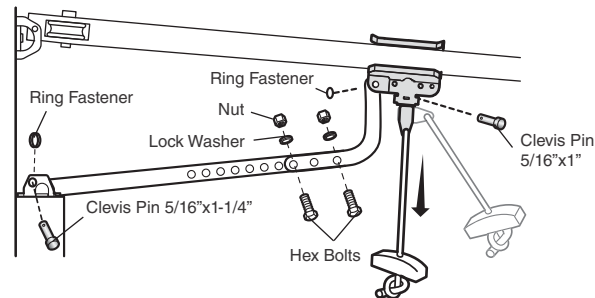

One-Piece Door with Track

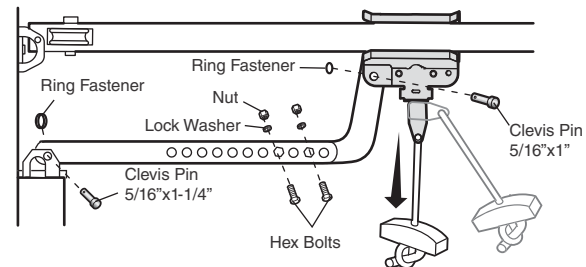

Installation

STEP 9 Install the Door Control

WARNING

To prevent possible **SERIOUS INJURY** or **DEATH** from electrocution:

- Be sure power is **NOT** connected **BEFORE** installing door control.
- Connect door control **ONLY** to 12 VOLT low voltage wires.

To prevent possible **SERIOUS INJURY** or **DEATH** from a closing garage door:

- Install door control within sight of garage door, out of reach of small children at a minimum height of 5 feet (1.5 m) above floors, landings, steps or any other adjacent walking surface, and away from ALL moving parts of door.
- **NEVER** permit children to operate or play with door control push buttons or remote control transmitters.
- Activate door **ONLY** when it can be seen clearly, is properly adjusted, and there are no obstructions to door travel.
- **ALWAYS** keep garage door in sight until completely closed. **NEVER** permit anyone to cross path of closing garage door.

INTRODUCTION

Older Chamberlain door controls and third party products are not compatible. Install door control within sight of garage door, out of reach of small children at a minimum height of 5 feet (1.5 m) above floors, landings, steps or any other adjacent walking surface, and away from ALL moving parts of door. For gang box installations it is not necessary to drill holes or install the drywall anchors. Use the existing holes in the gang box.

NOTE: Your product may look different than the illustrations.

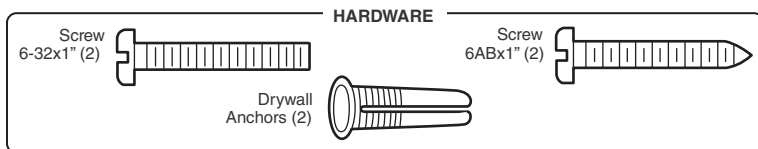

1. Strip 7/16" (11 mm) of insulation from one end of the wire and separate the wires.
2. Connect one wire to each of the two screws on the back of the door control. The wires can be connected to either screw. If your garage is pre-wired for the door control choose any two wires to connect, note which wires are used so the correct wires are connected to the garage door opener in a later step.
3. Mark the location of the bottom mounting hole and drill a 5/32" hole.
4. Install the bottom screw, allowing 1/8" (3 mm) to protrude from the wall.
5. Position the bottom hole of the door control over the screw and slide down into place.
6. Lift the push bar up and mark the top hole.
7. Remove the door control from the wall and drill a 5/32" hole for the top screw.
8. Position the bottom hole of the door control over the screw and slide down into place. Attach the top screw.

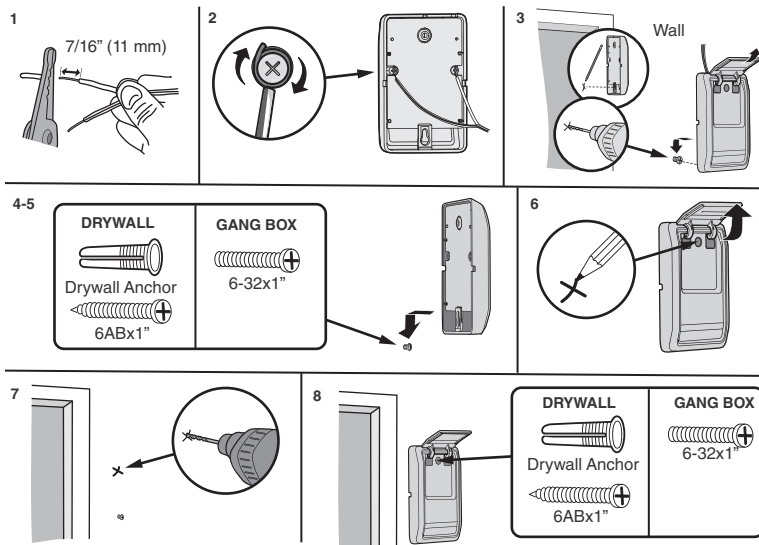

Installation

STEP 10 Wire the Door Control to the Garage Door Opener

1. Run the white and red/white wire from the door control to the garage door opener. Attach the wire to the wall and ceiling with the staple (not applicable for gang box or pre-wired installations). Do not pierce the wire with the staple as this may cause a short or an open circuit.
2. Strip 7/16" (11 mm) of insulation from the end of the wire near the garage door opener.
3. Connect the wire to the red and white terminals on the garage door opener. If your garage is pre-wired make sure you use the same wires that are connected to the door control. To insert or release wires from the terminal, push in the tab with screwdriver tip.

HARDWARE

Insulated Staple (Not Shown)

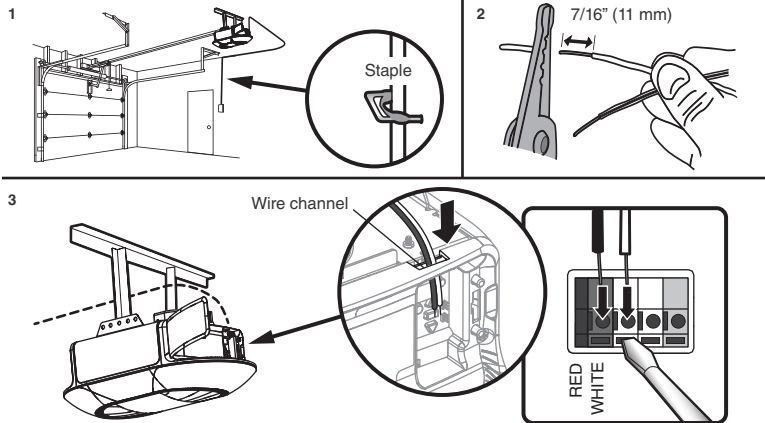

STEP 11 Attach the Warning Labels

1. Attach the entrapment warning label on the wall near the door control with tacks or staples.
2. Attach the manual release/safety reverse test label in a visible location on the inside of the garage door.

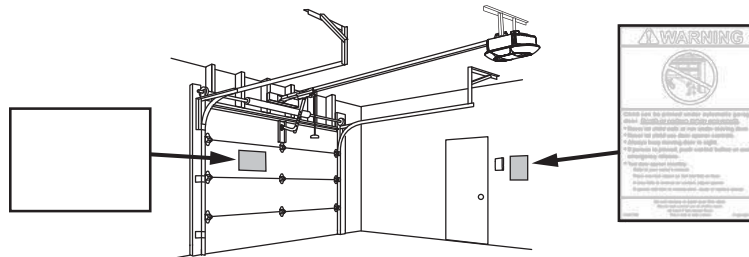

Installation

STEP 12 Install the Protector System®

Be sure power is NOT connected to the garage door opener BEFORE installing the safety reversing sensor. To prevent SERIOUS INJURY or DEATH from closing garage door:

- Correctly connect and align the safety reversing sensor. This required safety device MUST NOT be disabled.
- Install the safety reversing sensor so beam is NO HIGHER than 6" (15 cm) above garage floor.

IMPORTANT: The safety reversing sensors MUST be connected and aligned correctly before the garage door opener will move in the down direction.

The Protector System® includes two safety reversing sensors which use a light beam to prevent the garage door from closing. The sending sensor (amber LED) transmits the beam to the receiving sensor (green LED) when both are powered and aligned. If an obstruction breaks the light beam while the door is closing, the door will stop, and reverse to the full open position.

When installing the safety reversing sensors, check:

- Sensors are installed INSIDE the garage.
- Sensor lenses are facing each other. **IMPORTANT: Do not allow direct sunlight to the receiving sensor (green LED).**
- Sensor beam is NO HIGHER than 6" (15 cm) above the floor and the light beam is unobstructed.

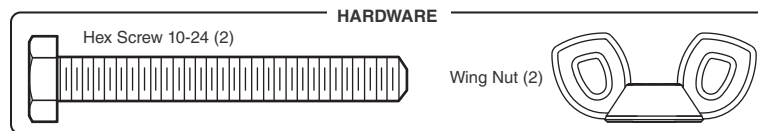
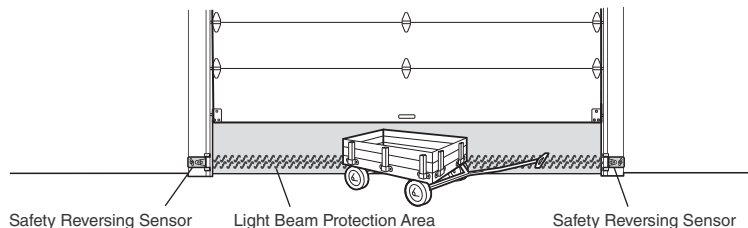

The safety reversing sensors are designed to clip onto the door track with the provided sensor brackets. If the door track will not support the sensor bracket a wall installation is recommended. The sensor beam should be NO HIGHER than 6" (15 cm) above the floor.

DOOR TRACK INSTALLATION

1. Slide the curved arms of the sensor bracket around the edge of the door track. Snap into place so that the sensor bracket is flush against the track.
2. Slide the hex screw through the sensor.
3. Attach the sensor to the bracket with the wing nut. Make sure the lens is not obstructed by the bracket.

Repeat the steps with the other sensor on the opposite door track. Both lenses must face each other.

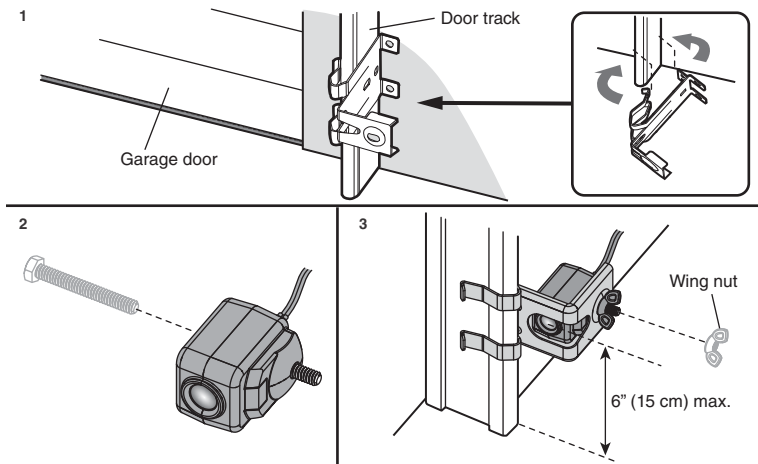

Installation

STEP 12 Install the Protector System (continued)

WALL OPTION

Make sure the brackets on each side are clear of the door track and have the same amount of clearance so the sensors will align correctly. If additional clearance is needed, use extension brackets 041A5281-1 (not provided) or wood blocks.

1. Attach the sensor bracket against the wall with two lag screws (not provided).
2. Slide the hex screw through the sensor.
3. Attach the sensor to the bracket with the wing nut. Make sure the lens is not obstructed by the bracket.

Repeat the steps with the other sensor on the opposite side of the garage door. Both lenses must face each other.

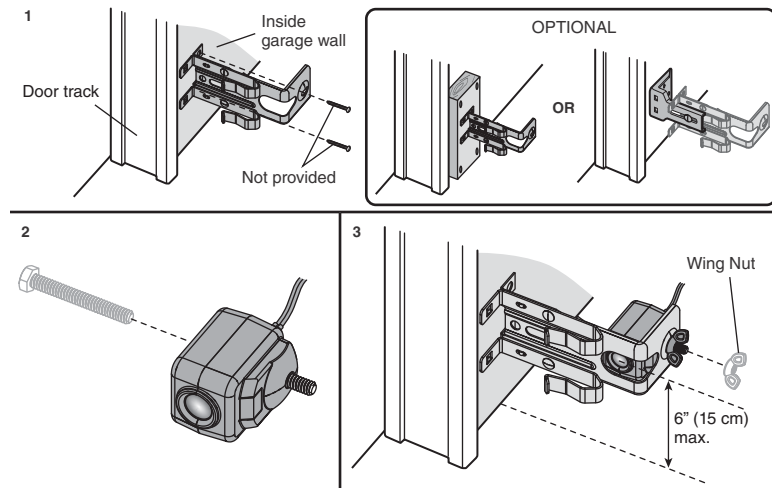

FLOOR OPTION

1. Measure the position of both sensor brackets so they will be the same distance from the wall and unobstructed.
2. Attach the bracket to the floor with concrete anchors (not provided).
3. Slide the hex screw through the sensor.
4. Attach the sensor to the bracket with the wing nut. Make sure the lens is not obstructed by the bracket.

Repeat the steps with the other sensor on the opposite side of the garage door. Both lenses must face each other.

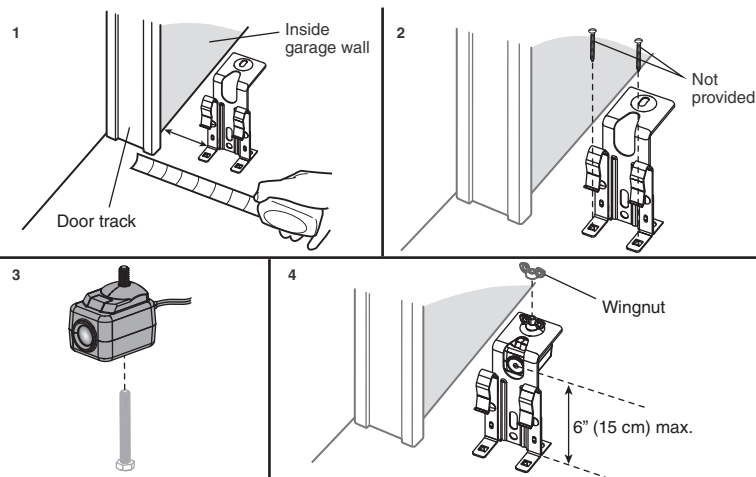

Installation

STEP 13 Wire the Safety Reversing Sensors

If your garage has pre-installed wiring for the safety reversing sensors, see OPTION B- PRE-WIRED INSTALLATION page 27.

OPTION A- INSTALLATION WITH NO PRE-WIRING

1. Run the wire from both sensors to the garage door opener. Attach with staples, but DO NOT puncture the wire.
2. Separate the sensor wires and strip insulation from each end. Twist the two white wires together. Then twist the two white/black wires together.
3. Using a screwdriver, push in the terminal tabs, and insert the white wires into the white terminal. Insert the white/black wires into the grey terminal.

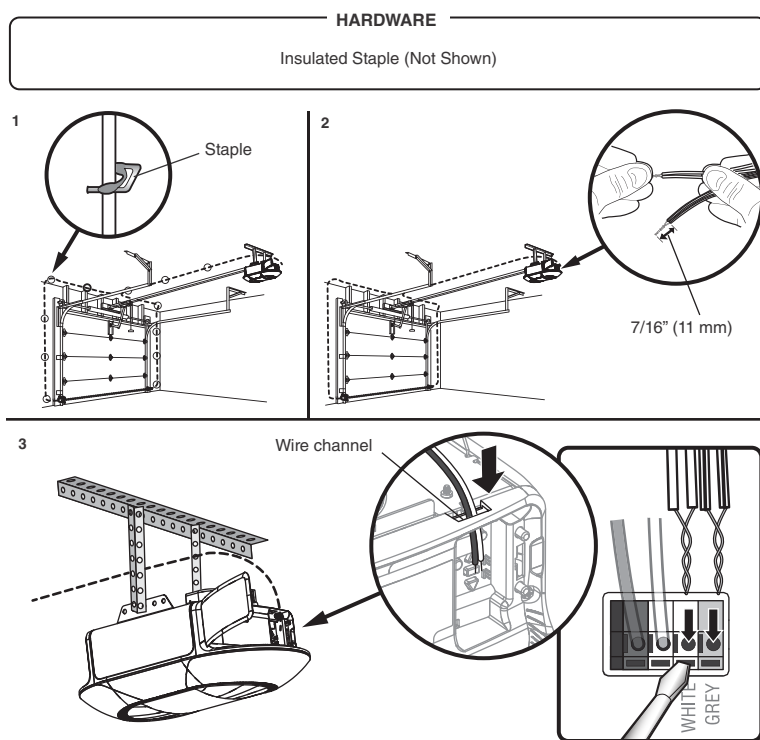

Installation

STEP 13 Wire the Safety Reversing Sensors (continued)

OPTION B- PRE-WIRED INSTALLATION

1. Cut the sensor wires, making sure there is enough wire to reach the pre-installed wires from the wall.
2. Separate the sensor wires and strip insulation from each end. Choose two of the pre-installed wires and strip insulation from each end. Choose the same color pre-installed wires for each sensor.
3. Connect the pre-installed wires to the sensor wires with wire nuts making sure the colors correspond for each sensor.
4. At the garage door opener, strip the end of the wires previously connected to the sensors. Twist the like-colored wires together.
5. Using a screwdriver, push in the terminal tabs, and insert the wire color connected to the sensor's white wire into the white terminal. Insert the other wire color connected to the sensor's white/black terminal.

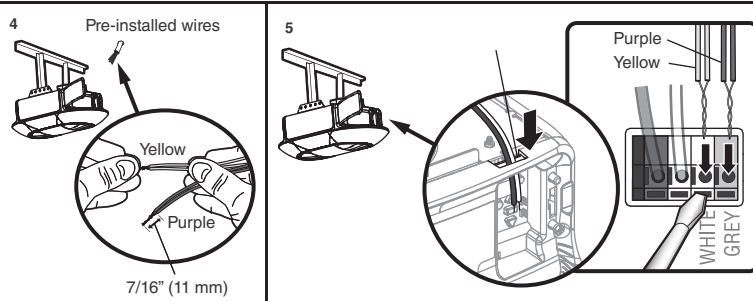
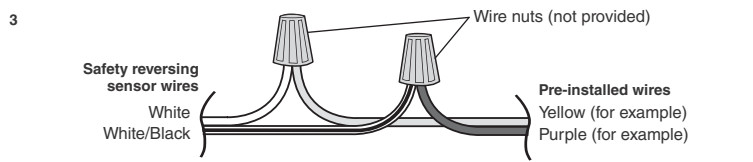
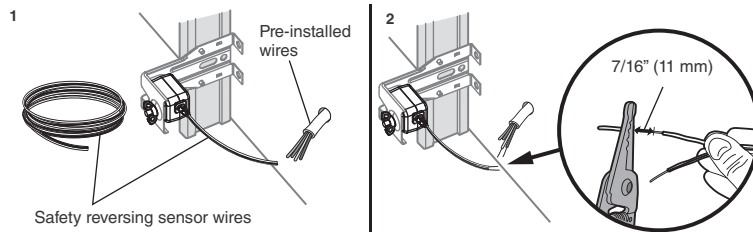

Installation

STEP 14 Connect Power

WARNING

To prevent possible **SERIOUS INJURY** or **DEATH** from electrocution or fire:

- Be sure power is **NOT** connected to the opener, and disconnect power to circuit **BEFORE** removing cover to establish permanent wiring connection.
- Garage door installation and wiring **MUST** be in compliance with **ALL** local electrical and building codes.
- **NEVER** use an extension cord, 2-wire adapter, or change plug in **ANY** way to make it fit outlet. Be sure the opener is grounded.

To avoid installation difficulties, do not run the opener at this time.

To reduce the risk of electric shock, your garage door opener has a grounding type plug with a third grounding pin. This plug will only fit into a grounding type outlet. If the plug doesn't fit into the outlet you have, contact a qualified electrician to install the proper outlet.

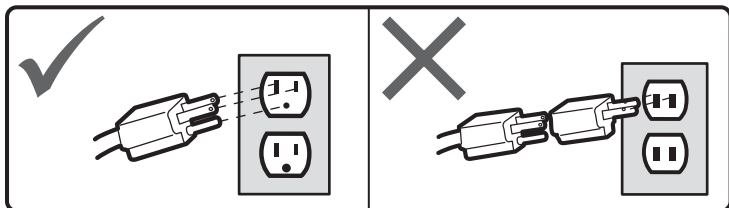

THERE ARE TWO OPTIONS FOR CONNECTING POWER:

OPTION A - TYPICAL WIRING

1. Plug in the garage door opener into a grounded outlet.
2. **DO NOT** run garage door opener at this time.

OPTION B - PERMANENT WIRING

If permanent wiring is required by your local code, refer to the following procedure. To make a permanent connection through the 7/8-inch hole in the top of the motor unit (according to local code):

1. Remove the motor unit cover screws and set the cover aside.
2. Remove the attached 3-prong cord.
3. Connect the black (line) wire to the screw on the brass terminal; the white (neutral) wire to the screw on the silver terminal; and the ground wire to the green ground screw. **The opener must be grounded.**
4. Reinstall the cover.

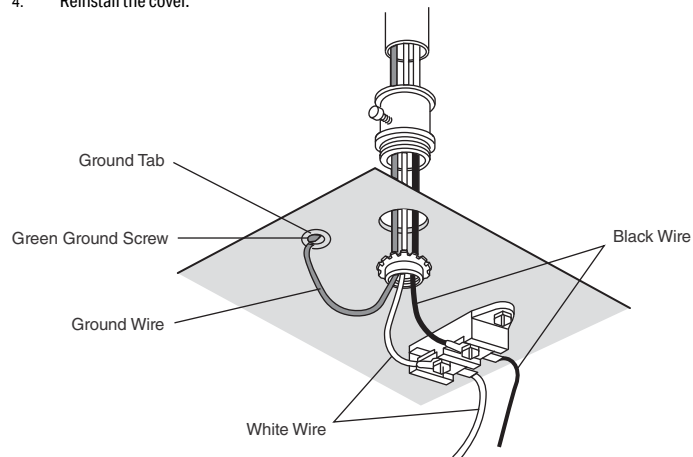

Installation

STEP 15 Align the Safety Reversing Sensors

IMPORTANT: The safety reversing sensors **MUST** be connected and aligned correctly before the garage door opener will move in the down direction.

When the garaged door opener has power, check the safety reversing sensors. If the sensors are aligned and wired correctly, both LEDs will glow steadily.

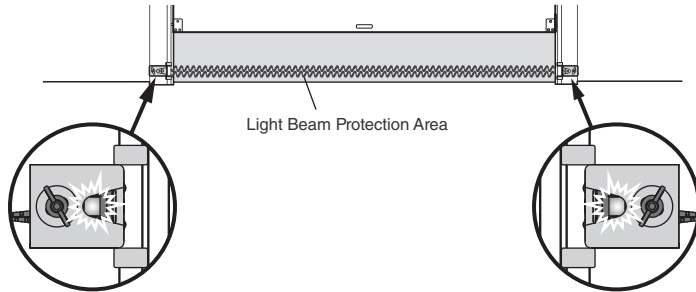

Sending sensor - amber LED

Receiving sensor - green LED
The receiving sensor has a sticker on the back.

To align the safety reversing sensors:

1. Loosen the wing nuts.
2. Adjust the sensors up or down until both LEDs glow steady indicating alignment.
3. Tighten the wing nut to secure the sensor.

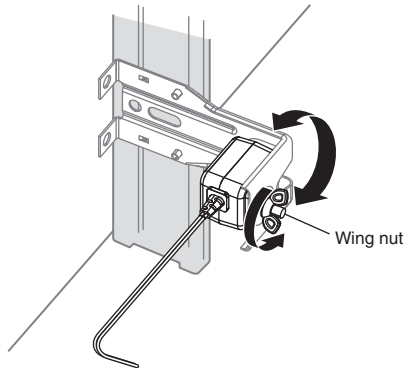

SAFETY SENSOR TROUBLESHOOTING

If either of the sensor LEDs are off, there is no power to the sensor:

1. Check that you have power to the garage door opener.
2. Check the sensor wire is not shorted or broken.
3. Check that the sensors is wired correctly; white wires to white terminal and white/black wires to grey terminal.

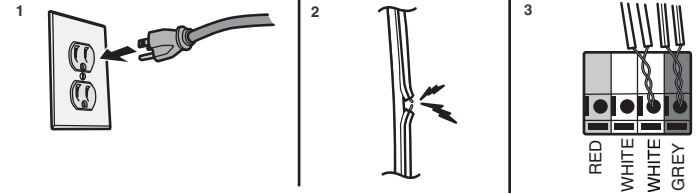

If the green receiving sensor LED is blinking, the sensors are obstructed or misaligned:

1. Check for obstructions in the sensor light beam.
2. Align the sensors.
3. If the receiving sensor (green LED) faces direct sunlight, switch the receiving sensor with the sending sensor and repeat STEP 12 Install the Protector System® page 26 to assure proper operation.

STEP 16 Ensure the Door Control is Wired Correctly

If the door control has been installed and wired correctly, the command LED on the Motion-Detecting Control Panel will blink.

Adjustment

Introduction

WARNING

Without a properly installed safety reversal system, persons (particularly small children) could be **SERIOUSLY INJURED** or **KILLED** by a closing garage door.

- Incorrect adjustment of garage door travel limits will interfere with proper operation of safety reversal system.
- After **ANY** adjustments are made, the safety reversal system **MUST** be tested. Door **MUST** reverse on contact with 1-1/2" (3.8 cm) high object (or 2x4 laid flat) on floor.

CAUTION

To prevent damage to vehicles, be sure fully open door provides adequate clearance.

Your garage door opener is designed with electronic controls to make setup and adjustments easy. While programming the travel, the UP and DOWN buttons can be used to move the door as needed. During the Automatic Force Setup, the door will automatically open and close.

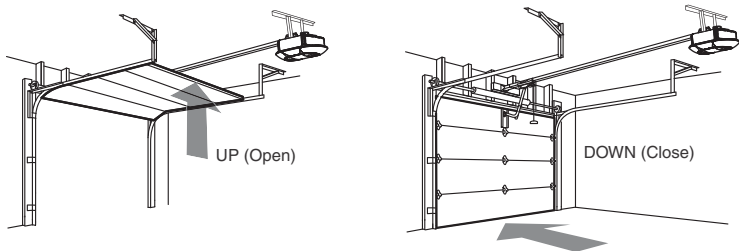

ONE-PIECE DOORS ONLY

When setting the UP travel for a one-piece door ensure that the door does not slant backwards when fully open (UP). If the door is slanted backwards this will cause unnecessary bucking and/or jerking when the door is opening or closing.

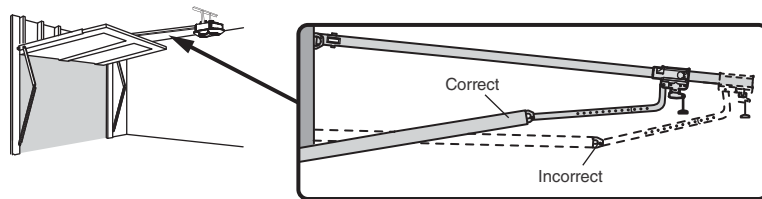

PROGRAMMING BUTTONS

The programming buttons are located on the left side panel of the garage door opener and are used to program the travel. While programming, the UP and DOWN buttons can be used to move the door as needed.

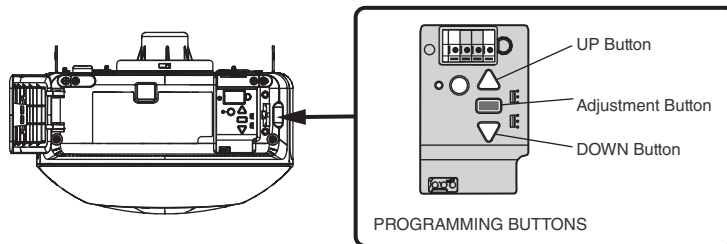

Adjustment

1 - Program the Travel

WARNING

Without a properly installed safety reversal system, persons (particularly small children) could be **SERIOUSLY INJURED** or **KILLED** by a closing garage door.

- Incorrect adjustment of garage door travel limits will interfere with proper operation of safety reversal system.
- After ANY adjustments are made, the safety reversal system **MUST** be tested. Door **MUST** reverse on contact with 1-1/2" (3.8 cm) high object (or 2x4 laid flat) on floor.

While programming the travel, the UP and DOWN buttons can be used to move the door as needed. The Safety Reversing Sensors will be disconnected during the Program the Travel process. During the Automatic Force Setup the door will automatically open and close.

- 1** Press and hold the Adjustment Button until the UP Button begins to flash and/or a beep is heard.



The Safety Reversing Sensors will be disconnected during the Program the Travel process.

- 2** Press and hold the UP Button until the door is in the desired UP position.



- 3** Once the door is in the desired UP position press and release the Adjustment Button. The garage door opener lights will flash twice and the DOWN Button will begin to flash.

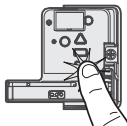

- 4** Press and hold the DOWN button until the door is in the desired DOWN position.



- 5** Once the door is in the desired DOWN position press and release the Adjustment Button. The garage door opener lights will flash twice. Program the Travel is now complete. If the garage door opener lights flash 5 times, then programming has timed out and the Travel Limits have not been set. Please restart the Program the Travel process.

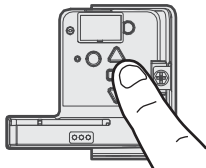

2 - Automatic Force Set Up

Once both the up and down positions have been manually set, the Safety Reversing Sensors will reconnect and become operational. Then, the opener will enter a force-sensing operation by automatically moving the door open and close. The garage door opener will sound an audible and visual alert before automatically opening and closing the door. The garage door opener will beep three times, confirming that the Automatic Force Setup completed successfully. Adjustment is complete.

If you hear one long beep after the door attempts to move, then the Automatic Force Set Up has not completed successfully. Please start over at step 1 of Program the Travel.



Adjustments

3 - Test the Safety Reversal System

WARNING

Without a properly installed safety reversal system, persons (particularly small children) could be **SERIOUSLY INJURED** or **KILLED** by a closing garage door.

- Safety reversal system **MUST** be tested every month.
- After **ANY** adjustments are made, the safety reversal system **MUST** be tested. Door **MUST** reverse on contact with 1-1/2" (3.8 cm) high object (or 2x4 laid flat) on the floor.

- 1 With the door fully open, place a 1-1/2 inch (3.8 cm) board (or a 2x4 laid flat) on the floor, centered under the garage door.



- 2 Press the remote control push button to close the door. The door **MUST** reverse when it makes contact with the board.



If the door stops but does not reverse:

1. Repeat Program the Travel (see Adjustment Step 1);
2. Repeat the Safety Reversal test.

If the test continues to fail, call a trained door systems technician.

4 - Test the Protector System®

WARNING

Without a properly installed safety reversing sensor, persons (particularly small children) could be **SERIOUSLY INJURED** or **KILLED** by a closing garage door.

- 1 Open the door. Place an obstruction in the path of the door.



- 2 Press the remote control push button to close the door. The door will not move more than an inch (2.5 cm).

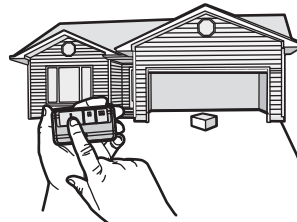

The garage door opener will not close from a remote control if the LED in either safety reversing sensor is off (alerting you to the fact that the sensor is misaligned or obstructed).

If the garage door opener closes the door when the safety reversing sensor is obstructed (and the sensors are no more than 6 inches [15 cm] above the floor), call for a trained door systems technician.

Battery Backup

STEP 1 Install the Battery

MODELS B4613TC, B6713TC, AND B6753TC

WARNING

To reduce the risk of FIRE or INJURY to persons:

- Disconnect ALL electric and battery power BEFORE performing ANY service or maintenance.
- Use ONLY Chamberlain part # G4228 for replacement battery.
- DO NOT dispose of battery in fire. Battery may explode. Check with local codes for disposal instructions.

CAUTION

ALWAYS wear protective gloves and eye protection when changing the battery or working around the battery compartment.

The battery backup allows access in and out of your garage, even when the power is out. The battery does not have to be fully charged to operate the garage door opener. When the garage door opener is operating on battery power, it may run slower and the battery status LED will glow solid orange while the motor is on. The following features are unavailable when operating on battery power:

- Garage door opener lights
- Unattended close devices and features such as myQ® App and Timer-to-Close

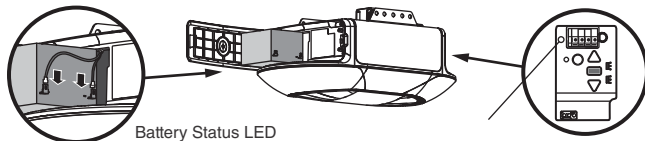

1. Unplug the garage door opener.
2. Open the control door panel on the front of the garage door opener
3. Partially insert the battery into the battery compartment with the terminals facing to the right as shown.
4. Connect red (+) and black (-) wires from the garage door opener to the corresponding terminals on the battery.
5. Fully insert the battery and close the control door panel.

STEP 2 Test the Battery

Depending on the power level, the battery may need to charge before performing the test. The garage door opener must be unplugged to test the battery.

1. Open and close the door using the remote control or door control. While the motor is on, the battery status LED will either glow solid orange indicating opener is operating on battery power or will flash indicating low battery power. **NOTE:** The garage door opener may run slower if the battery is not fully charged.
2. Plug in the garage door opener. Verify the battery status LED is flashing green, indicating the battery is charging.

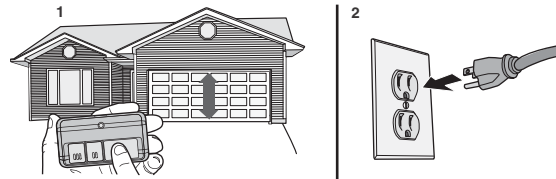

Charge the Battery

The battery charges when the garage door opener is plugged into a 120Vac electrical outlet that has power and requires 24 hours to fully charge. A fully charged battery supplies 12Vdc to the garage door opener for up to 24 hours during an electrical power outage. After the electrical power has been restored, the battery will recharge within 24 hours. The battery will last approximately 1 to 2 years with normal usage. Instructions for replacement are provided with the battery. To obtain maximum battery life and prevent damage, disconnect the battery when the garage door opener is unplugged for an extended period of time, such as a summer or winter home.

myQ® App Control

Connect With Your Smartphone

YOU WILL NEED:

- Wi-Fi enabled smartphone, tablet or laptop
- Broadband Internet connection
- Wi-Fi signal in the garage (**2.4 GHz, 802.11b/g/n required**), see page 5
- Password for your home network (router's main account, not guest network)
- myQ® serial number located on the garage door opener

DOWNLOAD THE myQ® APP TO SET UP AN ACCOUNT AND CONNECT

Open and close your door, get alerts and set schedules from anywhere. Connected smart garage door openers also receive software updates to ensure the opener has the latest operational features.

1. Download the myQ® App.
2. Set up an account and connect.

If you already have the myQ® App installed:

1. Check that your mobile device has the latest software.
2. Download the latest version of the myQ® App.

For more information on connecting your garage door opener, visit support.chamberlaingroup.com.



NOTES:

myQ® App control **WILL NOT** work if the garage door opener is operating on battery power. To erase the Wi-Fi settings from the opener, see page 39.

Google Play and the Google Play logo are trademarks of Google LLC.

App Store and the Apple and App Store logos are trademarks of Apple Inc.

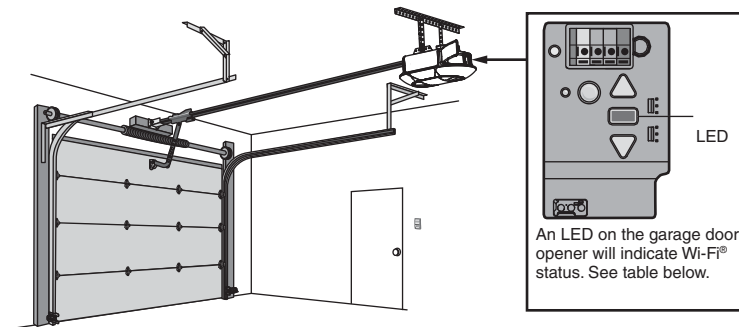

Wi-Fi® Status	
LED	Definition
Blue	Off - Wi-Fi® is not turned on. Blinking - Garage door opener is in Wi-Fi® learn mode. Solid - Mobile device connected to the garage door opener.
Blue and Green	Blinking - Attempting to connect to router.
Green	Blinking - Attempting to connect to the Internet server. Solid - Wi-Fi® has been set up and garage door opener is connected to the Internet.

Camera

Set Up the Camera

MODELS B4643TC AND B6753TC

1. Download the myQ® App, setup an account, and connect. See page 36.
2. Follow the instructions in the app to setup and use the camera.

The camera powers up when it is opened and powers down when closed. An LED on the camera indicates the status. See the camera status table.

For more information on using the camera, visit support.chamberlaingroup.com.

NOTES:

myQ® App control and camera WILL NOT work if the garage door opener is operating on battery power. To erase the camera settings from the opener, see page 41.

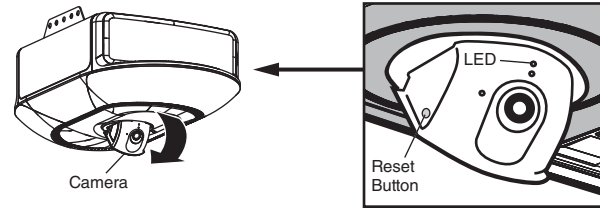

Camera Status	
LED	Definition
Flashing Blue	Camera is attempting to connect to the mobile device.
Solid Blue	Camera is connected to the mobile device.
Flashing Blue and Green	Camera is attempting to connect to the router.
Flashing Green	Camera is connected to the router and attempting to connect to myQ® server.
Solid Green	Camera is connected and working normally.
Solid White	Camera is powering up.
Flashing Red	Camera is overheating.
Flashing Purple	Camera firmware is updating.

IMPORTANT SAFETY INSTRUCTIONS



To reduce the risk of SEVERE INJURY or DEATH:

1. READ AND FOLLOW ALL WARNINGS AND INSTRUCTIONS.
2. ALWAYS keep remote controls out of reach of children. NEVER permit children to operate or play with garage door control push buttons or remote controls.
3. ONLY activate garage door when it can be seen clearly, it is properly adjusted, and there are no obstructions to door travel.
4. ALWAYS keep garage door in sight and away from people and objects until completely closed. NO ONE SHOULD CROSS THE PATH OF THE MOVING DOOR.
5. NO ONE SHOULD GO UNDER A STOPPED, PARTIALLY OPENED DOOR.
6. If possible, use emergency release handle to disengage trolley ONLY when garage door is CLOSED. Use caution when using this release with the door open. Weak or broken springs or unbalanced door could result in an open door falling rapidly and/or unexpectedly and increasing the risk of SEVERE INJURY or DEATH.
7. NEVER use emergency release handle unless garage doorway is clear of persons and obstructions.
8. NEVER use handle to pull garage door open or closed. If rope knot becomes untied, you could fall.
9. After ANY adjustments are made, the safety reversal system MUST be tested.
10. Safety reversal system MUST be tested every month. Garage door MUST reverse on contact with 1-1/2" (3.8 cm) high object (or a 2x4 laid flat) on the floor. Failure to adjust the garage door opener properly increases the risk of SEVERE INJURY or DEATH.
11. ALWAYS KEEP GARAGE DOOR PROPERLY BALANCED (see page 5). An improperly balanced door may NOT reverse when required and could result in SEVERE INJURY or DEATH.
12. ALL repairs to cables, spring assemblies and other hardware, ALL of which are under EXTREME tension, MUST be made by a trained door systems technician.
13. ALWAYS disconnect electric and battery power to garage door opener BEFORE making ANY repairs or removing covers.
14. This operator system is equipped with an unattended operation feature. The door could move unexpectedly. NO ONE SHOULD CROSS THE PATH OF THE MOVING DOOR.
15. DO NOT install on a one-piece door if using devices or features providing unattended close. Unattended devices and features are to be used ONLY with sectional doors.

16. SAVE THESE INSTRUCTIONS.

Using your Garage Door Opener

The garage door opener can be activated through a wall-mounted door control, remote control, wireless keyless entry or myQ® App.

When the door is closed and the garage door opener is activated the door will open. If the door makes contact with an obstruction while opening, the door will stop, opener beeps and lights flash 5 times. When the door is in any position other than closed and the garage door opener is activated, the door will close. If the garage door makes contact with an obstruction while closing, the door will reverse, opener beeps and lights flash 5 times. However, you can close the door if you hold the button on the door control or keyless entry until the door is fully closed.

The safety reversing sensors do not affect the opening cycle. The safety reversing sensor must be connected and aligned correctly before the garage door opener will move in the down direction.

The garage door opener lights will turn on when the opener is initially plugged in; power is restored after interruption, or when the garage door opener is activated. The lights will turn off automatically after 4-1/2 minutes.

Operation

Motion Detecting Control Panel

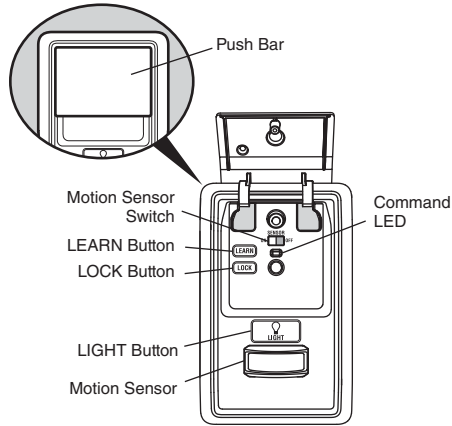

SYNCHRONIZE THE DOOR CONTROL: To synchronize the door control to the garage door opener, press the push bar until the garage door opener activates (it may take up to 3 presses). Test the door control by pressing the push bar; each press of the push bar will activate the garage door opener.

PUSH BAR: Press the push bar to open or close the door.

LEARN BUTTON: Use to program compatible remote controls, wireless keyless entries and myQ® devices to the garage door opener.

MOTION SENSOR: Turns the garage door opener lights on when motion is detected. Lights stay on for 4-1/2 minutes (factory setting), then turn off. Set the motion sensor switch ON or OFF to control this feature.

LOCK: Prevents remote controls from working, while still allowing activation from the door control and keyless entry. (Factory setting is OFF.)

Turn ON: Press and hold the LOCK button for 2 seconds. The command LED will flash as long as the lock feature is on.

Turn OFF: Press and hold the LOCK button for 2 seconds. The command LED will stop flashing and normal operation will resume.

LIGHT BUTTON: Turns the garage door opener lights on or off when pressed. Lights stay on for 4-1/2 minutes (factory setting). The LIGHT button will not control the lights when the door is in motion.

To change the amount of time the lights stay on:

Press and hold the LOCK button (approximately 10 seconds) until the garage door opener lights flash. The time interval is indicated by the number of times the garage door opener lights flash:

- 1 flash is 1-1/2 minutes
- 2 flashes is 2-1/2 minutes
- 3 flashes is 3-1/2 minutes
- 4 flashes is 4-1/2 minutes

To cycle through the time intervals repeat the step above. If the push bar LED is continuously blinking, the LOCK feature needs to be turned off.

To turn the light feature ON (Factory default is On):

1. Close the garage door.
2. Start with the garage door opener lights "ON".
3. Press and hold the LIGHT button (approximately 10 seconds) until the garage door opener lights turn off, then on again.

To turn the light feature OFF:

1. Close the garage door.
2. Start with the garage door opener lights "OFF".
3. Press and hold the LIGHT button (approximately 10 seconds) until the garage door opener lights turn off, then on again.