

INSIGNIA™

Flat size (W×H): 317.5 × 241.3 mm.  
Final folded size: 105.83 × 241.3 mm.

QUICK SETUP GUIDE

# Portable Bluetooth Stereo Speaker

NS-CSPBTWP1

PACKAGE CONTENTS

- Speaker
- USB cable
- Quick Setup Guide

v1  
R3

IMPORTANT SAFETY INSTRUCTIONS

- 1 Read these instructions. All the safety and operating instructions should be read before this product is operated.
- 2 Keep these instructions. The safety and operating instructions should be retained for future reference.
- 3 Heed all warnings. All warnings on the appliance and in the operating instructions should be adhered to.
- 4 Follow all instructions. All operating and use instructions should be followed.
- 5 Clean only with a dry cloth.
- 6 Do not block any ventilation openings. Install in accordance with the manufacturer's instructions.
- 7 Do not install near any heat sources such as radiators, heat registers, stoves, or other apparatus (including amplifiers) that produce heat.
- 8 Do not defeat the safety purpose of the polarized or grounding plug. A polarized plug has two blades with one wider than the other. A grounding plug has two blades and a third grounding prong. The wide blade or the third prong is provided for your safety. If the provided plug does not fit into your outlet, consult an electrician for replacement of the obsolete outlet.
- 9 Protect the power cord from being walked on or pinched particularly at the plugs, convenience receptacles, and at the point where they exit from the apparatus.
- 10 Only use attachments/accessories specified by the manufacturer.
- 11 Unplug the apparatus during lightning storms or when unused for long periods of time.
- 12 Refer all servicing to qualified personnel. Servicing is required when the apparatus has been damaged in any way, such as the power supply cord or plug is damaged, liquid has been spilled or objects have fallen into the apparatus, the apparatus has been exposed to rain or moisture, does not operate normally, or has been dropped.
- 13 Do not install this equipment in a confined or built-in space such as a book case or similar unit. It shall remain in a well ventilated space. The ventilation should not be impeded by covering the ventilation openings with items such as newspaper, table-cloths, curtains, etc.
- 14 **WARNING:** To reduce the risk of fire or electric shock, do not expose this apparatus to rain or moisture. The apparatus shall not be exposed to dripping or splashing and objects filled with liquids, such as vases, shall not be placed on the apparatus.
- 15 **WARNING:** The power adapter is used as the disconnect device. It shall remain readily operable.
- 16 The equipment shall be used at a maximum of 95° F (35° C) ambient temperature.
- 17 **WARNING:** Please refer to the information on the exterior bottom enclosure for electrical and safety information before installing or operating the apparatus.

FEATURES

- Wirelessly stream from any Bluetooth device
- Rechargeable battery with 20-hour playback
- 14,000 mAH battery with USB port to charge your devices
- Waterproof (IPX7)

Control panel functions:

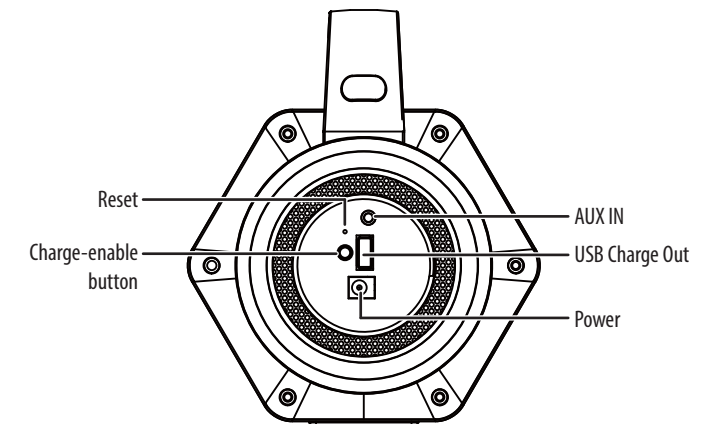
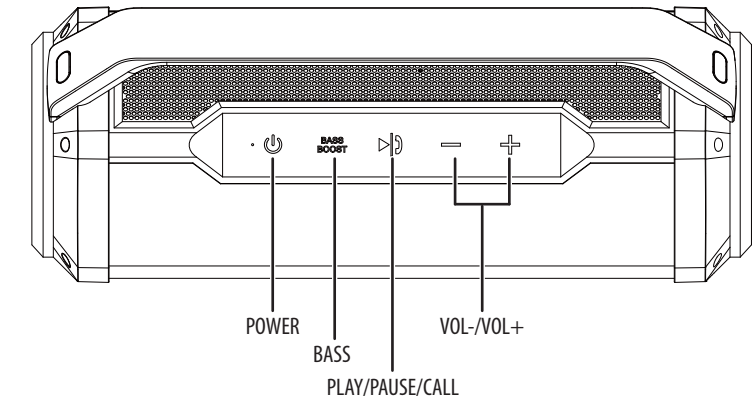

FEATURE	DESCRIPTION
Power	Press to turn the speaker on and off.
BASS	Press to turn the bass on and off.
PLAY/PAUSE/CALL	<ul style="list-style-type: none"> <li>• Press to mute/unmute in AUX mode.</li> <li>• Press to play/pause in BT mode.</li> <li>• Press to answer an incoming call in BT mode. Press this button again to hang up the call.</li> <li>• Press and hold for three seconds to reject the call in BT mode.</li> <li>• Press and hold for three seconds to switch between phone and speakerphone when in call.</li> <li>• Press and hold for three seconds to enter pairing mode while in BT mode.</li> </ul>
VOL+/-	Press to increase or decrease the volume.
Charge-enable button	Press to disable/enable charge output on the USB port when in standby mode.
Reset	Press to complete a hardware reset.

## USING YOUR BLUETOOTH SPEAKER

- 1 Press the **POWER** button to turn on the speaker. When the speaker is on, the blue LED lights on the left of the power button.
- 2 Press the **VOL-/VOL+** button to adjust the volume. The blue LED flashes once with each press. Hold the **VOL-/VOL+** button. The blue LED flashes rapidly.
- 3 Press the **PLAY** button to play or pause the speaker in Bluetooth mode.  
**Note:** In standby mode, press the **CHARGE** button to enable USB charging.

### Bluetooth mode

- 1 Turn on the speaker. Bluetooth pairing is automatically turned on and the blue LED flashes.
- 2 On your Bluetooth device, click "NS-CSPBTWP1" to pair with the speaker.
- 3 After pairing successfully, the LED flashes slowly.
- 4 If there is an incoming call, the LED flashes quickly.  
**Note:** After switching to Bluetooth mode, the speaker automatically searches for a Bluetooth device and reconnects if the devices have paired before. If it doesn't find any paired device, it will enter pairing mode to search for new devices.

### AUX mode

- The speaker automatically switches to AUX mode when you plug in an AUX cable. Bluetooth mode is disabled.  
**Note:** Press the **PLAY** button to mute the speaker when playing music. Press again to unmute.

STATE	LED
<b>BT pairing mode</b>	Blue LED fast flash
<b>BT connect mode</b>	Blue LED slow flash
<b>BT playing mode</b>	Blue LED fade in/out
<b>Incoming call</b>	Blue LED flash
<b>Bass boost on</b>	Blue LED flash once
<b>Bass boost off</b>	Blue LED flash twice
<b>AUX mute</b>	Blue LED slow flash
<b>AUX play</b>	Blue LED fade in/out
<b>Charging</b>	Red LED solid
<b>Full charge</b>	Red LED off

## SPECIFICATIONS

- Power output: 30W
- USB cable: 19.7 in. (0.5 m)

## TROUBLESHOOTING

PROBLEM	SOLUTION
<b>No power</b>	<ul style="list-style-type: none"> <li>• Make sure that your speaker is plugged in and turned on.</li> </ul>
<b>No sound or low volume</b>	<ul style="list-style-type: none"> <li>• Make sure that your Bluetooth device is turned on, Bluetooth is turned on, and <b>NS-CSPBTWP1</b> is selected.</li> <li>• Turn up the volume on your speaker.</li> <li>• Turn up the volume on your Bluetooth device.</li> <li>• Make sure that your Bluetooth device is not muted.</li> <li>• Make sure that your speaker is not paired to another Bluetooth device.</li> <li>• Make sure that your Bluetooth device is not paired to another Bluetooth device.</li> </ul>
<b>Cannot establish Bluetooth connection</b>	<ul style="list-style-type: none"> <li>• Shorten the distance between your speaker and your Bluetooth device.</li> <li>• Turn your devices off, then on. Re-pair your speaker and your Bluetooth device.</li> <li>• Make sure that your speaker is not paired to another Bluetooth device.</li> <li>• Make sure that your speaker and Bluetooth device are both in pairing mode.</li> <li>• Make sure that your Bluetooth device supports Bluetooth v4.0 and below.</li> <li>• Make sure that your Bluetooth device is not connected to any other device.</li> <li>• Make sure that you have selected <b>NS-CSPBTWP1</b> on your Bluetooth device.</li> </ul>
<b>My Bluetooth device keeps unpairing</b>	<ul style="list-style-type: none"> <li>• Shorten the distance between your speaker and your Bluetooth device.</li> <li>• If the battery on your Bluetooth device is low, recharge the battery.</li> </ul>
<b>"NS-CSPBTWP1" does not appear on my Bluetooth device</b>	<ul style="list-style-type: none"> <li>• Shorten the distance between your speaker and your Bluetooth device.</li> <li>• Put your speaker into pairing mode, then refresh your list of Bluetooth devices. For more information, see the documentation that came with your Bluetooth device.</li> </ul>

## LEGAL NOTICES

**Warning:** Changes or modifications to this unit not expressly approved by the party responsible for compliance could void the user's authority to operate the equipment.  
**Note:** This equipment has been tested and found to comply with the limits for a Class B digital device, pursuant to Part 15 of the FCC Rules. These limits are designed to provide reasonable protection against harmful interference in a residential installation. This equipment generates, uses and can radiate radio frequency energy and, if not installed and used in accordance with the instructions, may cause harmful interference to radio communications.

However, there is no guarantee that interference will not occur in a particular installation. If this equipment does cause harmful interference to radio or television reception, which can be determined by turning the equipment off and on, the user is encouraged to try to correct the interference by one or more of the following measures:  
—Reorient or relocate the receiving antenna.  
—Increase the separation between the equipment and receiver.  
—Connect the equipment into an outlet on a circuit different from that to which the receiver is connected.  
—Consult the dealer or an experienced radio/TV technician for help.

This device complies with Part 15 of the FCC Rules. Operation is subject to the following two conditions:

- (1) this device may not cause harmful interference, and
- (2) this device must accept any interference received, including interference that may cause undesired operation.

The device has been evaluated to meet general RF exposure requirement. The device can be used in portable exposure condition without restriction.

### Industry Canada Compliance IC Statement

This device complies with Industry Canada licence-exempt RSS standard(s).

Operation is subject to the following two conditions:

- (1) this device may not cause interference, and
- (2) this device must accept any interference, including interference that may cause undesired operation of the device.

Le présent appareil est conforme aux CNR d'Industrie Canada applicables aux appareils radio exempts de licence. L'exploitation est autorisée aux deux conditions suivantes :

- (1) l'appareil ne doit pas produire de brouillage, et
- (2) l'utilisateur de l'appareil doit accepter tout brouillage radioélectrique subi, même si le brouillage est susceptible d'en compromettre le fonctionnement.

### ONE-YEAR LIMITED WARRANTY

Visit [www.insigniaproducts.com](http://www.insigniaproducts.com) for details.

### CONTACT INSIGNIA:

1-877-467-4289 (U.S. and Canada)

01-800-926-3000 (Mexico)

[www.insigniaproducts.com](http://www.insigniaproducts.com)

INSIGNIA is a trademark of Best Buy and its affiliated companies  
Distributed by Best Buy Purchasing, LLC  
7601 Penn Ave South, Richfield, MN 55423 U.S.A.  
©2017 Best Buy. All rights reserved.  
Made in China