



**FCC & Industry Canada Certification Test Report**  
**For the**  
**Symbol Technologies, Inc.**  
**MR400**

**FCC ID: H9PMR400**  
**IC ID: 1549D-MR400**

**WLL JOB# 9284**  
**September 22, 2006**

Prepared for:

**Symbol Technologies, Inc.**  
**One Symbol Plaza**  
**Holtsville, NY 11742**

Prepared By:

**Washington Laboratories, Ltd.**  
**7560 Lindbergh Drive**  
**Gaithersburg, Maryland 20879**

**FCC & Industry Canada Certification Test Report**  
**for the**  
**Symbol Technologies, Inc.**  
**MR400**  
**FCC ID: H9PMR400**  
**IC ID: 1549D-MR400**

**September 22, 2006**

WLL JOB# 9284

Prepared by: Brian J. Dettling  
Documentation Specialist

Reviewed by: Michael F. Violette, P.E.  
President

## Abstract

This report has been prepared on behalf of Symbol Technologies, Inc. to support the attached Application for Equipment Authorization. The test report and application are submitted for a Frequency Hopping Spread Spectrum Transmitter under Part 15.247 of the FCC Rules and Regulations and Spectrum Management and Telecommunications Policy RSS-210 of Industry Canada.. This Certification Test Report documents the test configuration and test results for a Symbol Technologies, Inc. MR400.

Testing was performed on an Open Area Test Site (OATS) of Washington Laboratories, Ltd, 7560 Lindbergh Drive, Gaithersburg, MD 20879. Site description and site attenuation data have been placed on file with the FCC's Sampling and Measurements Branch at the FCC laboratory in Columbia, MD. The Industry Canada OATS numbers are 3035A-1 and 3035A-2 for Washington Laboratories, Ltd. Site 1 and Site 2, respectively. Washington Laboratories, Ltd. has been accepted by the FCC and approved by NIST NVLAP (NVLAP Lab Code: 200066-0) as an independent FCC test laboratory.

The Symbol Technologies, Inc. MR400 complies with the limits for a Frequency Hopping Spread Spectrum Transmitter device under FCC Part 15.247 and Industry Canada RSS-210.

Table of Contents

Abstract..... ii

1 Introduction..... 1

    1.1 Compliance Statement ..... 1

    1.2 Test Scope..... 1

    1.3 Contract Information..... 1

    1.4 Test Dates ..... 1

    1.5 Test and Support Personnel ..... 1

    1.6 Test Summary ..... 1

    1.7 Abbreviations..... 2

2 Equipment Under Test ..... 3

    2.1 EUT Identification & Description ..... 3

    2.2 Test Configuration ..... 3

    2.3 Testing Algorithm..... 4

    2.4 Test Location ..... 4

    2.5 Measurements ..... 5

        2.5.1 References..... 5

    2.6 Measurement Uncertainty..... 5

3 Test Equipment ..... 6

4 Test Results..... 7

    4.1 Duty Cycle Correction ..... 7

    4.2 RF Power Output: (FCC Part §2.1046) ..... 9

    4.3 Occupied Bandwidth: (FCC Part §2.1049)..... 16

    4.4 Channel Spacing and Number of Hop Channels (FCC Part §15247(a)(1)..... 19

    4.5 Conducted Spurious Emissions at Antenna Terminals (FCC Part §2.1051) ..... 22

    4.6 Radiated Spurious Emissions: (FCC Part §2.1053)..... 53

**4.6.1 Test Procedure** ..... 53

    4.7 AC Powerline Conducted Emissions: (FCC Part §15.207 and RSS-GEN)..... 58

List of Tables

Table 1. Device Summary..... 3

Table 2: Test Equipment List..... 6

Table 3. RF Power Output, Low Power..... 9

Table 4. RF Power Output, High Power ..... 9

Table 5. Occupied Bandwidth Results..... 18

Table 6: Radiated Emission Test Data, Low Frequency Data (<1GHz) ..... 55

Table 7: Radiated Emission Test Data, High Frequency Data (>1GHz) (Restricted Bands)..... 56

Table 8. Conducted Emissions Test Data; §15.207 ..... 58

List of Figures

Figure 2-1: Test Configuration ..... 4  
Figure 4-1. Duty Cycle Plot, Pulse Width ..... 7  
Figure 4-2. Time of Occupancy, 20 sec ..... 8  
Figure 4-3. RF Peak Power (Low), Low Channel ..... 10  
Figure 4-4. RF Peak Power (Low), Mid Channel ..... 11  
Figure 4-5. RF Peak Power (Low), High Channel ..... 12  
Figure 4-6. RF Peak Power (High), Low Channel ..... 13  
Figure 4-7. RF Peak Power (High), Mid Channel ..... 14  
Figure 4-8. RF Peak Power (High), High Channel ..... 15  
Figure 4-9. Occupied Bandwidth, Low Channel ..... 16  
Figure 4-10. Occupied Bandwidth, Mid Channel ..... 17  
Figure 4-11. Occupied Bandwidth, High Channel ..... 18  
Figure 4-12. Channel Spacing, 500kHz ..... 20  
Figure 4-13. Number of Channels ..... 21  
Figure 4-14. Conducted Spurious Emissions (Low Power), Low Channel 30 - 800MHz ..... 23  
Figure 4-15. Conducted Spurious Emissions (Low Power), Low Channel 800 - 1000MHz ..... 24  
Figure 4-16. Conducted Spurious Emissions (Low Power), Low Channel 1 - 5GHz ..... 25  
Figure 4-17. Conducted Spurious Emissions (Low Power), Low Channel 5 - 9.5GHz ..... 26  
Figure 4-18. Conducted Spurious Emissions (Low Power), Mid Channel 30 - 800MHz ..... 27  
Figure 4-19. Conducted Spurious Emissions (Low Power), Mid Channel 800 - 1000MHz ..... 28  
Figure 4-20. Conducted Spurious Emissions (Low Power), Mid Channel 1 - 5GHz ..... 29  
Figure 4-21. Conducted Spurious Emissions (Low Power), Mid Channel 5 - 9.5GHz ..... 30  
Figure 4-22. Conducted Spurious Emissions (Low Power), High Channel 30 - 800MHz ..... 31  
Figure 4-23. Conducted Spurious Emissions (Low Power), High Channel 800 - 1000MHz ..... 32  
Figure 4-24. Conducted Spurious Emissions (Low Power), High Channel 1 - 5GHz ..... 33  
Figure 4-25. Conducted Spurious Emissions (Low Power), High Channel 5 - 9.5GHz ..... 34  
Figure 4-26. Conducted Spurious Emissions (High Power), Low Channel 30 - 800MHz ..... 35  
Figure 4-27. Conducted Spurious Emissions (High Power), Low Channel 800 - 1000MHz ..... 36  
Figure 4-28. Conducted Spurious Emissions (High Power), Low Channel 1 - 5GHz ..... 37  
Figure 4-29. Conducted Spurious Emissions (High Power), Low Channel 5 - 9.5GHz ..... 38  
Figure 4-30. Conducted Spurious Emissions (High Power), Mid Channel 30 - 800MHz ..... 39  
Figure 4-31. Conducted Spurious Emissions (High Power), Mid Channel 800 - 1000MHz ..... 40  
Figure 4-32. Conducted Spurious Emissions (High Power), Mid Channel 1 - 5GHz ..... 41  
Figure 4-33. Conducted Spurious Emissions (High Power), Mid Channel 5 - 9.5GHz ..... 42  
Figure 4-34. Conducted Spurious Emissions (High Power), High Channel 30 - 800MHz ..... 43  
Figure 4-35. Conducted Spurious Emissions (High Power), High Channel 800 - 1000MHz ..... 44  
Figure 4-36. Conducted Spurious Emissions (High Power), High Channel 1 - 5GHz ..... 45  
Figure 4-37. Conducted Spurious Emissions (High Power), High Channel 5 - 9.5GHz ..... 46  
Figure 4-38. Conducted Bandedge, Low Channel, Low Power ..... 47  
Figure 4-39. Conducted Bandedge, Low Channel, High Power ..... 48  
Figure 4-40. Conducted Bandedge, Low Channel, Hopping ..... 49  
Figure 4-41. Conducted Bandedge, High Channel, Low Power ..... 50  
Figure 4-42. Conducted Bandedge, High Channel, High Power ..... 51  
Figure 4-43. Conducted Bandedge, High Channel, Hopping ..... 52

# 1 Introduction

## 1.1 Compliance Statement

The Symbol Technologies, Inc. MR400 complies with the limits for a Frequency Hopping Spread Spectrum Transmitter device under FCC Part 15.247 and Industry Canada RSS-210.

## 1.2 Test Scope

Tests for radiated and conducted (at antenna terminal) emissions were performed. All measurements were performed in accordance with FCC Public Notice DA 00-705 and the 2003 version of ANSI C63.4. The measurement equipment conforms to ANSI C63.2 Specifications for Electromagnetic Noise and Field Strength Instrumentation.

## 1.3 Contract Information

Customer: Symbol Technologies, Inc.  
One Symbol Plaza  
Holtsville, NY 11742

Purchase Order Number: 4500572771

Quotation Number: 62663-A

## 1.4 Test Dates

Testing was performed on the following date(s): August 15 to August 29, 2006

## 1.5 Test and Support Personnel

Washington Laboratories, LTD James Ritter, John Repella

Client Representative Alan Parish

## 1.6 Test Summary

The following is a brief summary of the tests performed on the Symbol Technologies, Inc. MR400 RFID Reader.

Section	Requirement	Report Section	Pass/Fail
15.247(b)	Output Power	4.2	Pass
2.1049	Occupied Bandwidth	4.3	Pass
15.247(a)(1)	Channel Spacing and Number of Hop Channels	4.4	Pass
15.247(d)	Conducted Spurious Emissions	4.5	Pass
15.247(c)	Radiated Spurious Emissions	4.6	Pass
15.207	AC Powerline Conducted Emissions	4.7	Pass

## 1.7 Abbreviations

<b>A</b>	<b>Ampere</b>
<b>ac</b>	<b>alternating current</b>
<b>AM</b>	<b>Amplitude Modulation</b>
<b>Amps</b>	<b>Amperes</b>
<b>b/s</b>	<b>bits per second</b>
<b>BW</b>	<b>BandWidth</b>
<b>CE</b>	<b>Conducted Emission</b>
<b>cm</b>	<b>centimeter</b>
<b>CW</b>	<b>Continuous Wave</b>
<b>dB</b>	<b>deciBel</b>
<b>dc</b>	<b>direct current</b>
<b>EMI</b>	<b>Electromagnetic Interference</b>
<b>EUT</b>	<b>Equipment Under Test</b>
<b>FM</b>	<b>Frequency Modulation</b>
<b>G</b>	<b>giga - prefix for 10<sup>9</sup> multiplier</b>
<b>Hz</b>	<b>Hertz</b>
<b>IF</b>	<b>Intermediate Frequency</b>
<b>k</b>	<b>kilo - prefix for 10<sup>3</sup> multiplier</b>
<b>LISN</b>	<b>Line Impedance Stabilization Network</b>
<b>M</b>	<b>Mega - prefix for 10<sup>6</sup> multiplier</b>
<b>m</b>	<b>meter</b>
<b>μ</b>	<b>micro - prefix for 10<sup>-6</sup> multiplier</b>
<b>NB</b>	<b>Narrowband</b>
<b>QP</b>	<b>Quasi-Peak</b>
<b>RE</b>	<b>Radiated Emissions</b>
<b>RF</b>	<b>Radio Frequency</b>
<b>rms</b>	<b>root-mean-square</b>
<b>SN</b>	<b>Serial Number</b>
<b>S/A</b>	<b>Spectrum Analyzer</b>
<b>V</b>	<b>Volt</b>

## 2 Equipment Under Test

### 2.1 EUT Identification & Description

The Symbol Technologies, Inc. MR400 is a frequency-hopping RFID reader module for incorporation into an end-user product.

**Table 1. Device Summary**

ITEM	DESCRIPTION
Manufacturer:	Symbol Technologies, Inc.
FCC ID:	H9PMR400
IC:	1549D-MR400
Model:	MR400
FCC Rule Parts:	§15.247
Industry Canada:	RSS210
Frequency Range:	902.75M – 927.25MHz
Maximum Output Power:	933mW (29.7dBm)
Modulation:	AM
Occupied Bandwidth:	80.74kHz
Keying:	Automatic
Type of Information:	Data
Number of Channels:	50
Power Output Level	Fixed
Antenna Connector	N-type
Antenna Type	6dBi
Interface Cables:	Antenna, Com, Power
Power Source & Voltage:	5Vdc from 120Vac

### 2.2 Test Configuration

The MR400 was configured with an antenna, a power supply, and a support PC for control. See the following figure. Since the device is a module the unit was tested in 3 orthogonal orientations for the radiated emissions testing.



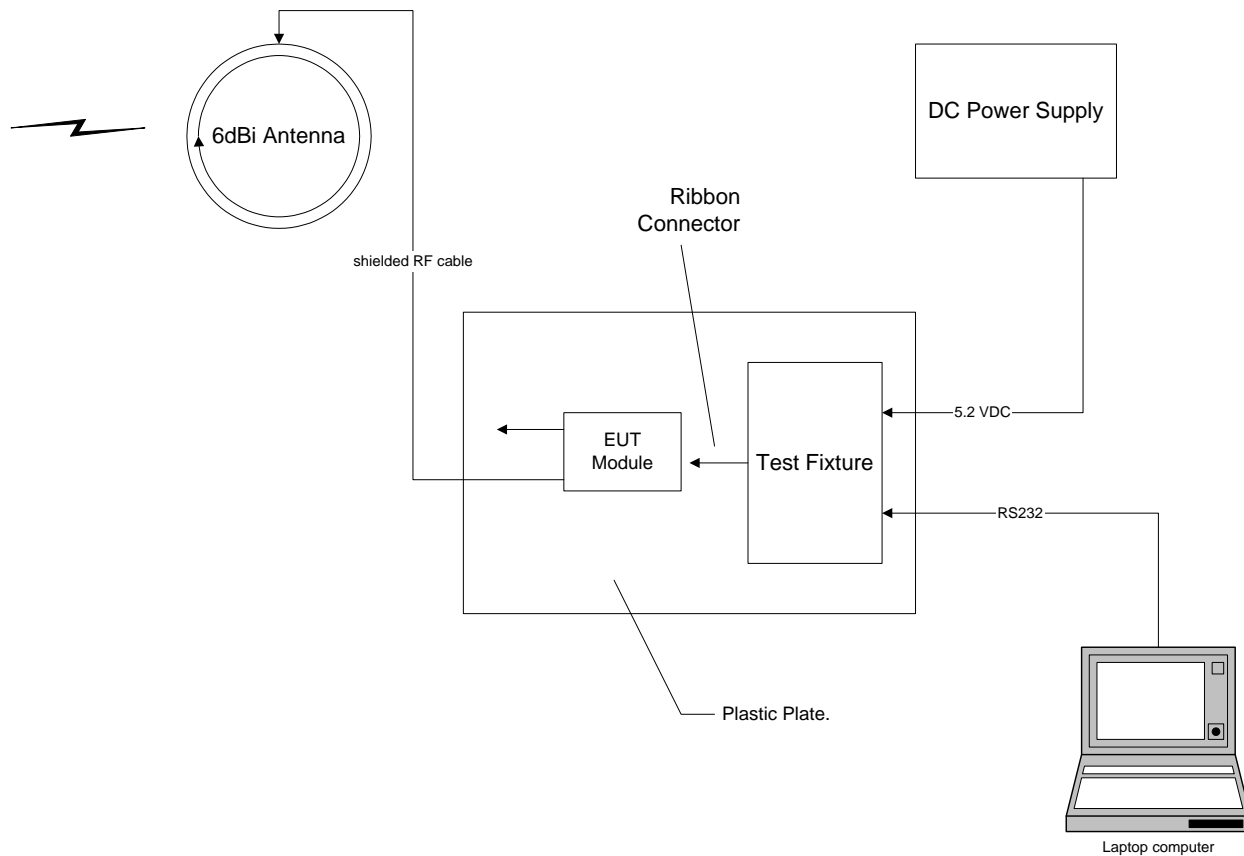

**Figure 2-1: Test Configuration.**

### 2.3 Testing Algorithm

The MR400 was power via a level converter test fixture with 5.2VDC from a DC power Supply. A support laptop connected to the test fixture via RS232 for communications. The test fixture provided power and communications with the EUT module over a ribbon cable assembly. Two programs on laptop controlled the EUT, A tag tracker program 5.3.0 controlled the unit during hopping operations and a Tera Term Pro Utility provided the ability to have the unit transmit on individual channels.

### 2.4 Test Location

All measurements herein were performed at Washington Laboratories, Ltd. test center in Gaithersburg, MD. Site description and site attenuation data have been placed on file with the FCC's Sampling and Measurements Branch at the FCC laboratory in Columbia, MD. The Industry Canada OATS numbers are 3035A-1 and 3035A-2 for Washington Laboratories, Ltd. Site 1 and Site 2, respectively. Washington Laboratories, Ltd. has been accepted by the FCC and approved by NIST NVLAP (NVLAP Lab Code: 200066-0) as an independent FCC test laboratory.

## 2.5 Measurements

### 2.5.1 References

FCC Public Notice DA 00-705, Filing and Measurement Guidelines for Frequency Hopping Spread Spectrum Systems

ANSI C63.2 Specifications for Electromagnetic Noise and Field Strength Instrumentation

ANSI C63.4 American National Standard for Methods of Measurement of Radio-Noise Emissions from Low-Voltage Electrical and Electronic Equipment in the Range of 9 kHz to 40 GHz

### 2.6 Measurement Uncertainty

All results reported herein relate only to the equipment tested. For the purposes of the measurements performed by Washington Laboratories, the measurement uncertainty is  $\pm 2.3$  dB. This has been calculated for a *worst-case situation* (radiated emissions measurements performed on an open area test site).

The following measurement uncertainty calculation is provided:

$$\text{Total Uncertainty} = (A^2 + B^2 + C^2)^{1/2}/(n-1)$$

where:

A = Antenna calibration uncertainty, in dB = 2 dB

B = Spectrum Analyzer uncertainty, in dB = 1 dB

C = Site uncertainty, in dB = 4 dB

n = number of factors in uncertainty calculation = 3

Thus, Total Uncertainty =  $0.5 (2^2 + 1^2 + 4^2)^{1/2} = \pm 2.3$  dB.

### 3 Test Equipment

Table 2 shows a list of the test equipment used for measurements along with the calibration information.

**Table 2: Test Equipment List**

Test Name: <b>Radiated Emissions</b>		Test Date: <b>8/23/2006</b>	
<b>Asset #</b>	<b>Manufacturer/Model</b>	<b>Description</b>	<b>Cal. Due</b>
00071	HP8568A	PRESELECTOR, RF	6/26/2007
00073	HP, 8568B	ANALYZER, SPECTRUM	6/26/2007
00069	HP, 85650A	ADAPTER, QP	6/26/2007
00004	ARA, DRG-118/A	ANTENNA, DRG, 1-18GHZ	2/02/2007
00522	HP, 8449B	PRE-AMPLIFIER, 1-26.5GHZ	5/04/2007
00074	HP, 8593A	ANALYZER, SPECTRUM	10/04/2006
00280	ITC, 21C-3A1	WAVEGUIDE 3.45-11.0GHZ	6/12/2008
00337	WLL, 1.2-5GHZ	FILTER, BAND PASS	2/07/2007
00557	SCHAFFNER, CBL6141A	ANTENNA, BILOG	12/01/2006

Test Name: <b>Conducted Emissions Voltage</b>		Test Date: <b>8/29/2006</b>	
<b>Asset #</b>	<b>Manufacturer/Model</b>	<b>Description</b>	<b>Cal. Due</b>
00068	HP, 85650A	ADAPTER, QP	7/3/2007
00072	HP, 8568B	ANALYZER, SPECTRUM	7/3/2007
00125	SOLAR, 8028-50-TS-24-BNC	LISN	1/31/2007
00126	SOLAR, 8028-50-TS-24-BNC	LISN	1/31/2007
00053	HP, 11947A	LIMITER, TRANSIENT	4/24/2007

## 4 Test Results

### 4.1 Duty Cycle Correction

In accordance with the FCC Public Notice DA 00-705 and Pt 15.209 the spurious radiated harmonic emissions measurements may be adjusted using a duty cycle correction factor in addition to video averaging if the dwell time per channel of the hopping signal is less than 100 ms.

The duty cycle correction factor is calculated by:

$$20 \times \text{LOG} (\text{dwell time}/100 \text{ ms})$$

The following figures show the plots of the dwell time for the transmitter. Based on these plots, the total dwell time per 100 ms is 30ms. This corresponds to a duty cycle correction of 10.45dB; The maximum allowed duty cycle correction is 20dB.

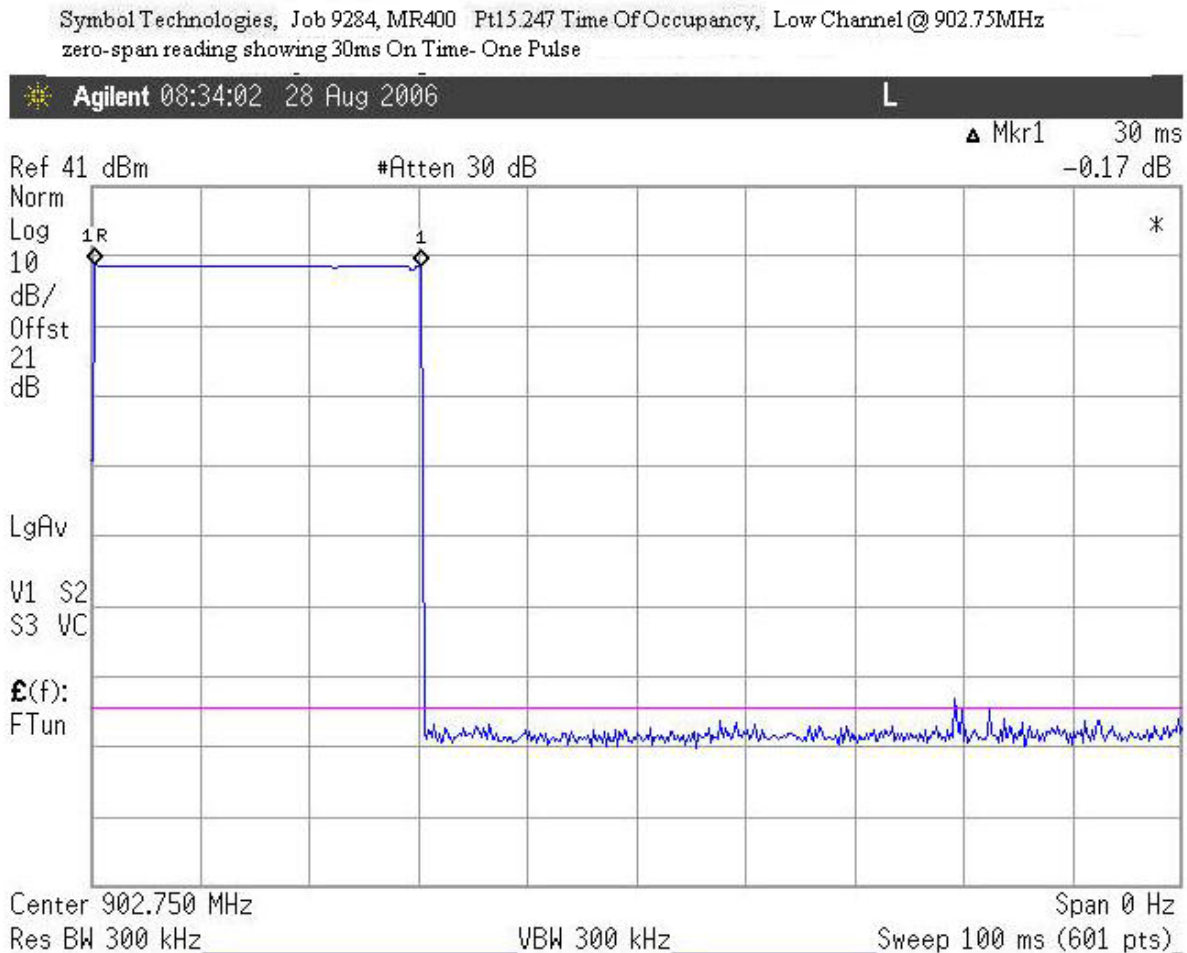

Figure 4-1. Duty Cycle Plot, Pulse Width

Symbol Technologies, Job 9284, Pt15.247(i) Dwell Time Per 20 Second Period,  
20 Second period based on a Signal bandwidth of 80kHz in the 902-928MHz Band  
Total Dwell time = 12Pulses (1 at trigger time) of 30ms for a total of 360ms. Limit =400ms per 20 Second Period

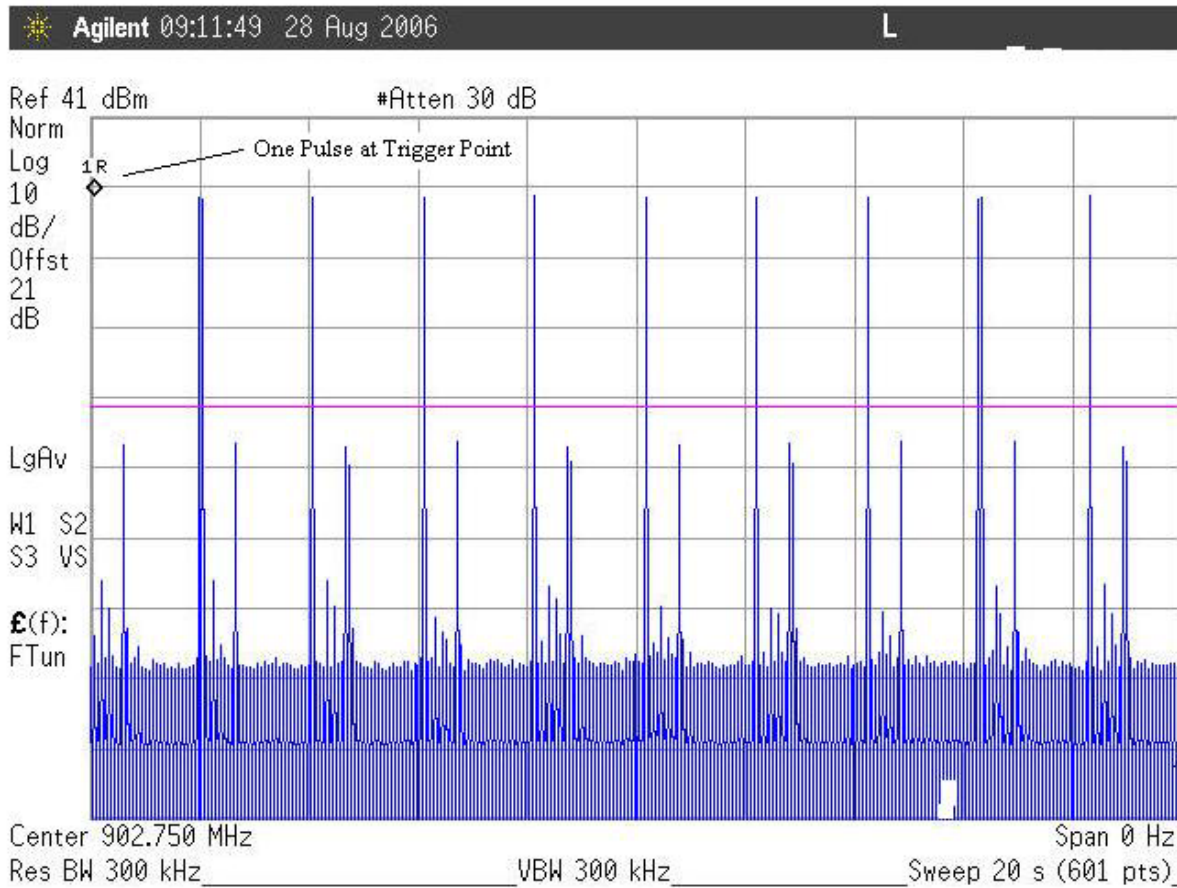

Figure 4-2. Time of Occupancy, 20 sec

#### 4.2 RF Power Output: (FCC Part §2.1046)

To measure the output power the hopping sequence was stopped while the frequency dwelled on a low, high and middle channel. The output from the transmitter was connected to an attenuator and then to the input of the RF Spectrum Analyzer. The analyzer offset was adjusted to compensate for the attenuator and other losses in the system.

**Table 3. RF Power Output, Low Power**

Frequency	Level	Limit	Pass/Fail
Low Channel 902.75MHz	13.8 dBm	30 dBm	Pass
Mid Channel 914.75MHz	13.5 dBm	30 dBm	Pass
High Channel 927.25MHz	13.8 dBm	30 dBm	Pass

**Table 4. RF Power Output, High Power**

Frequency	Level	Limit	Pass/Fail
Low Channel 902.75MHz	29.7 dBm	30 dBm	Pass
Mid Channel 914.75MHz	29.5 dBm	30 dBm	Pass
High Channel 927.25MHz	29.6 dBm	30 dBm	Pass

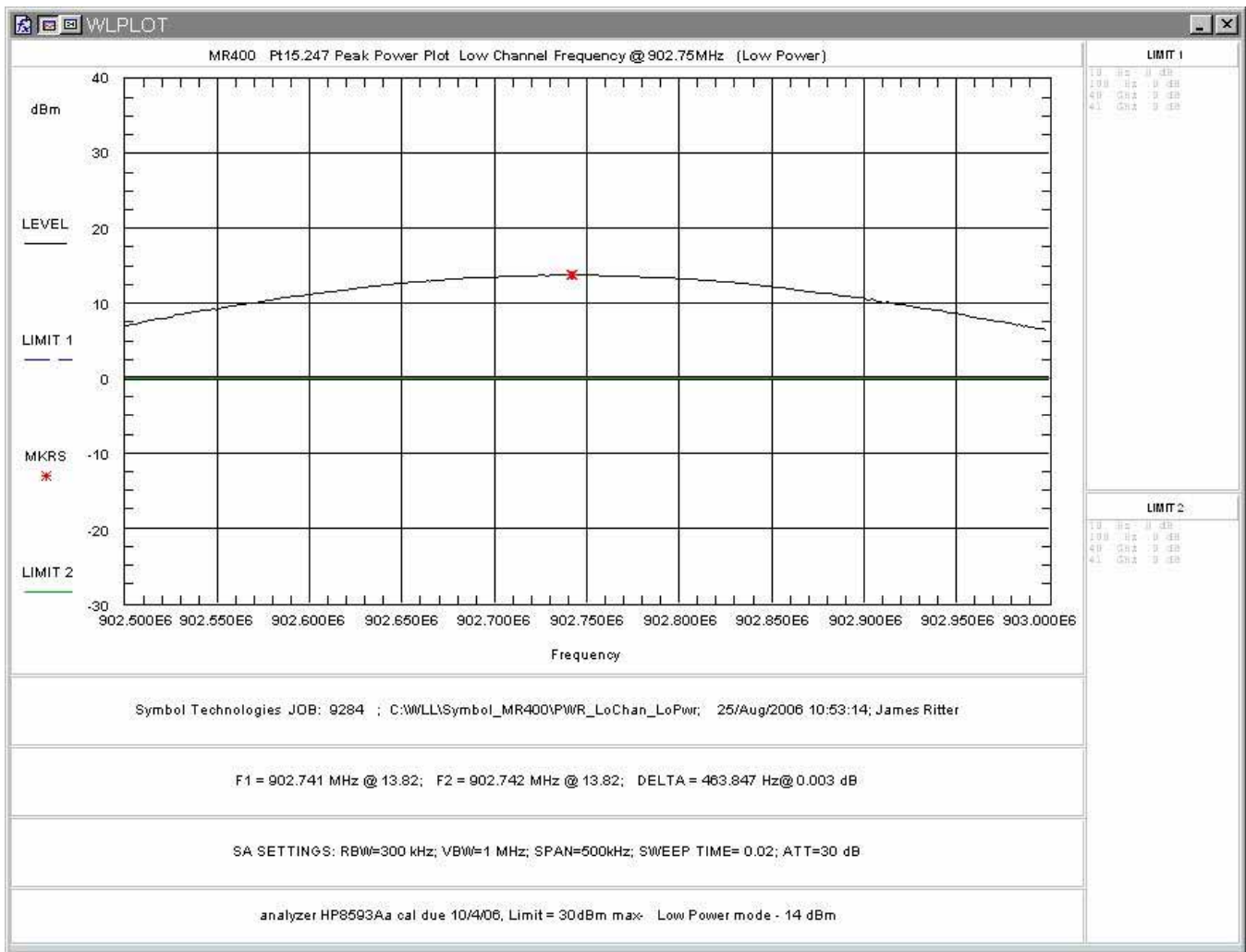

Figure 4-3. RF Peak Power (Low), Low Channel

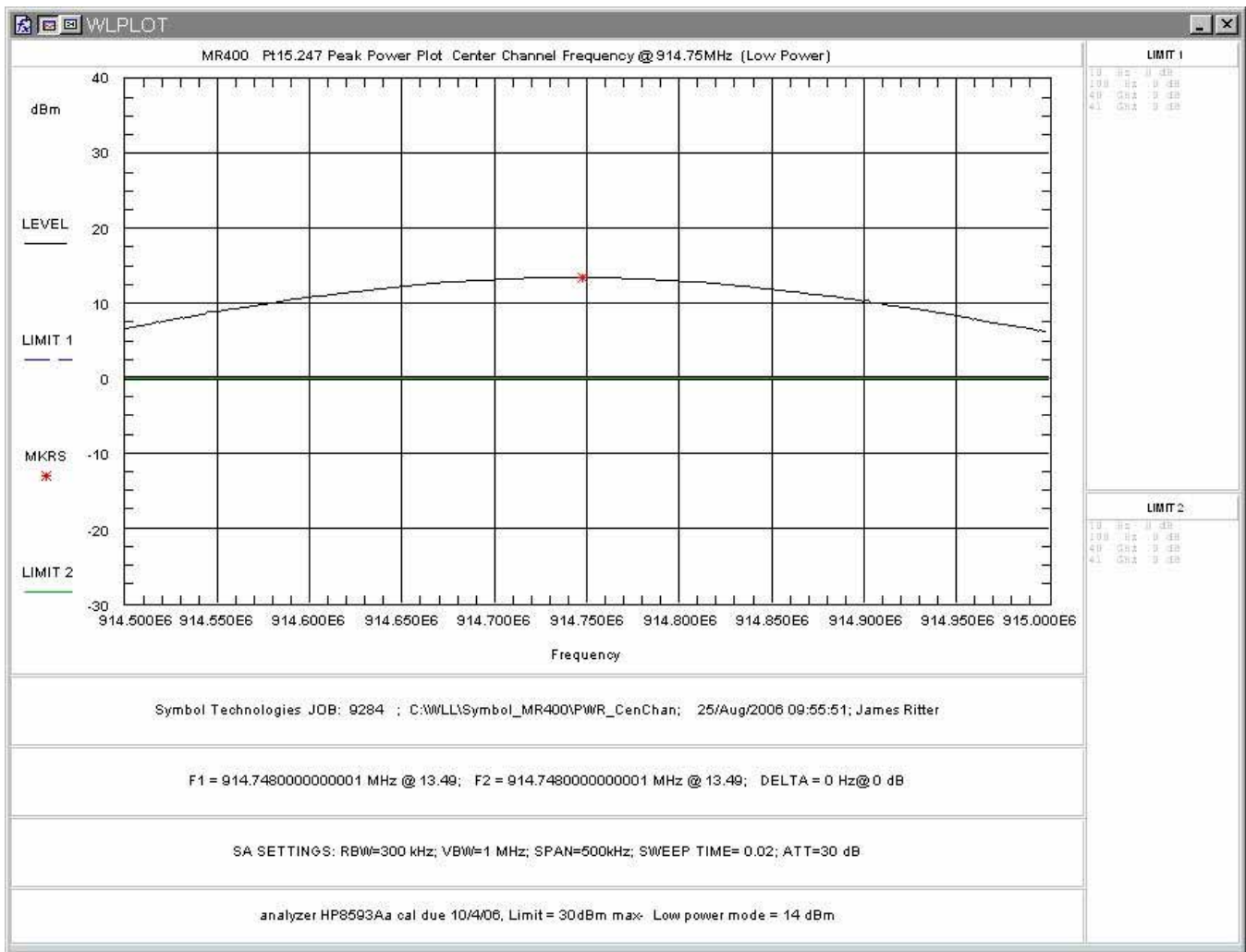

Figure 4-4. RF Peak Power (Low), Mid Channel



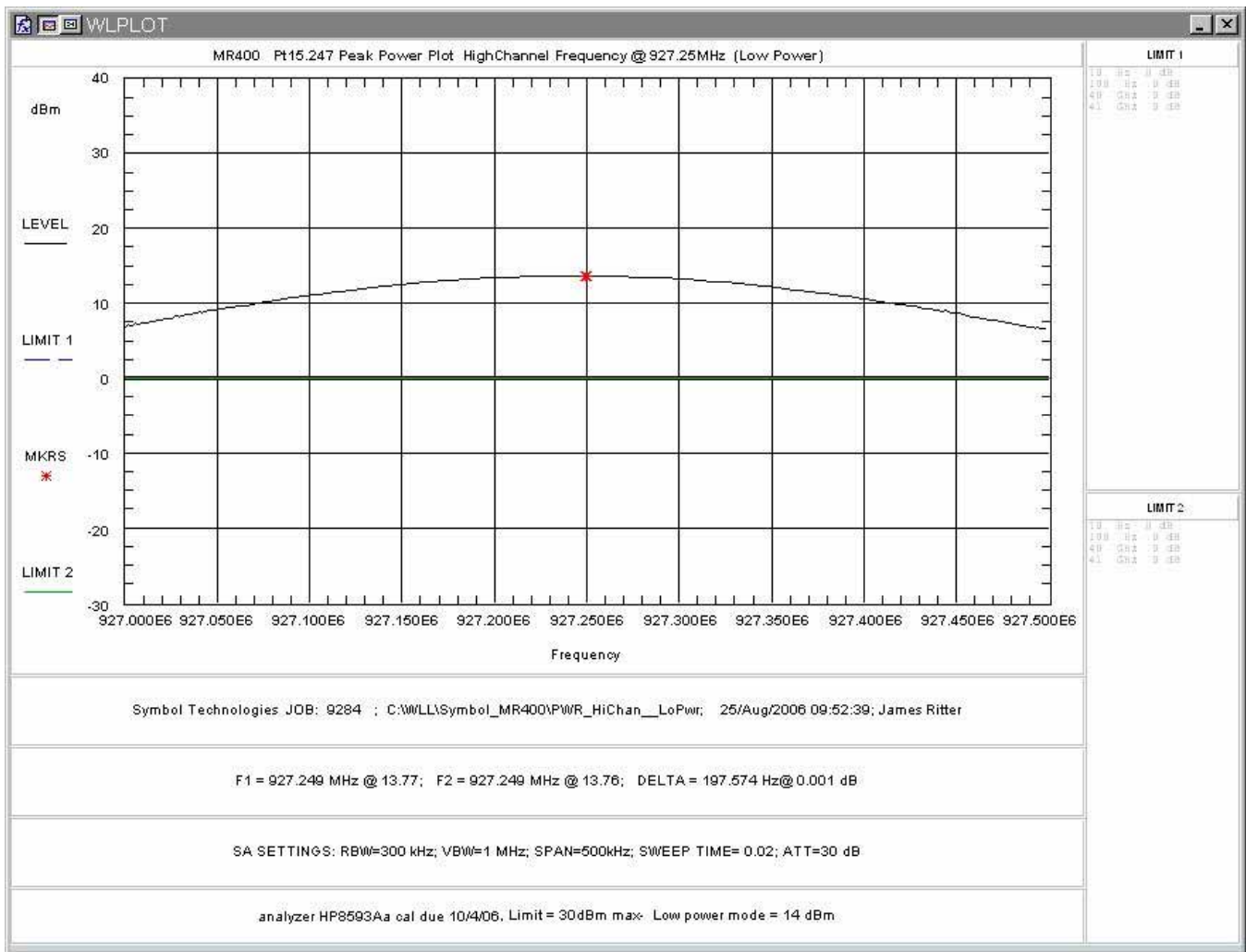

Figure 4-5. RF Peak Power (Low), High Channel

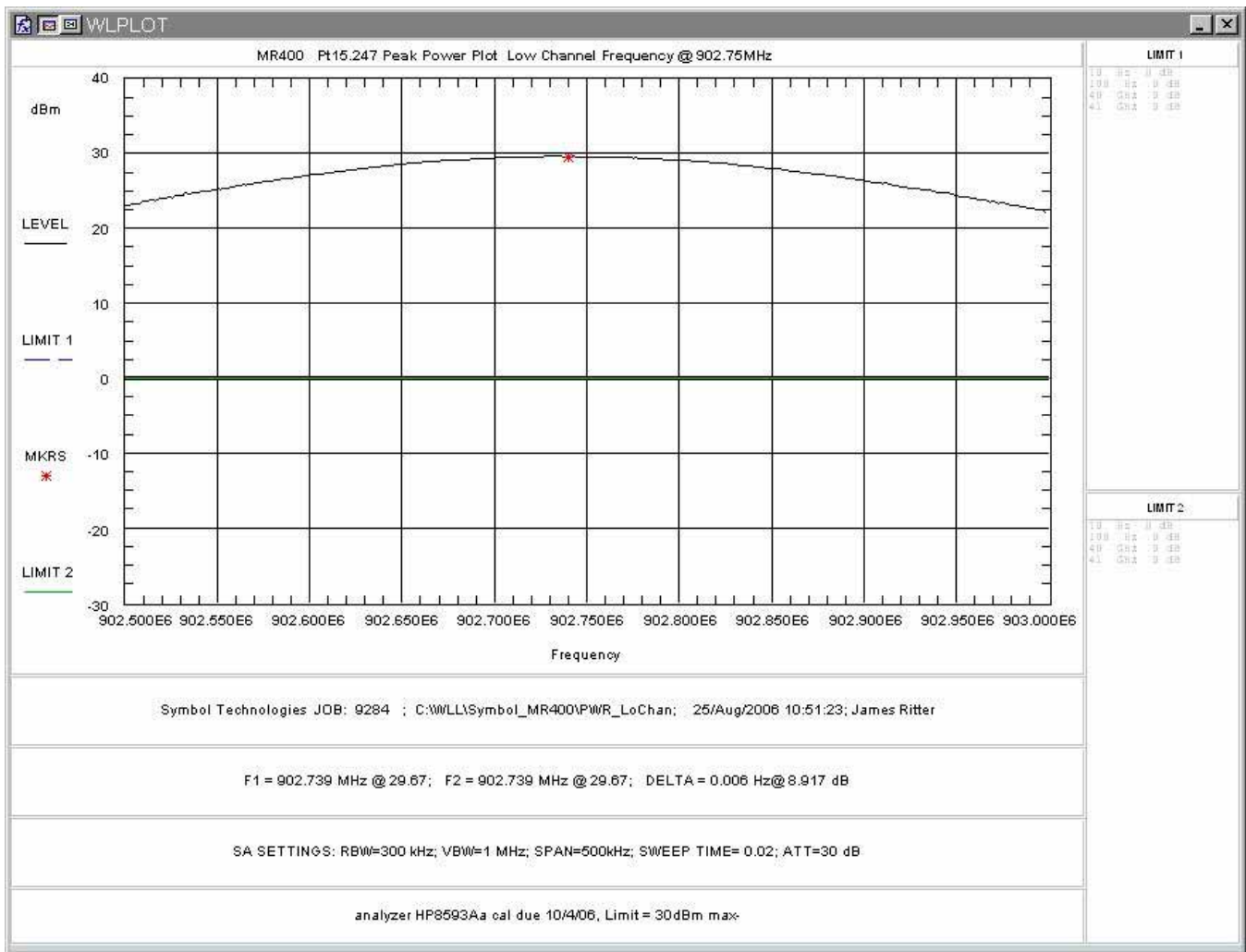

Figure 4-6. RF Peak Power (High), Low Channel

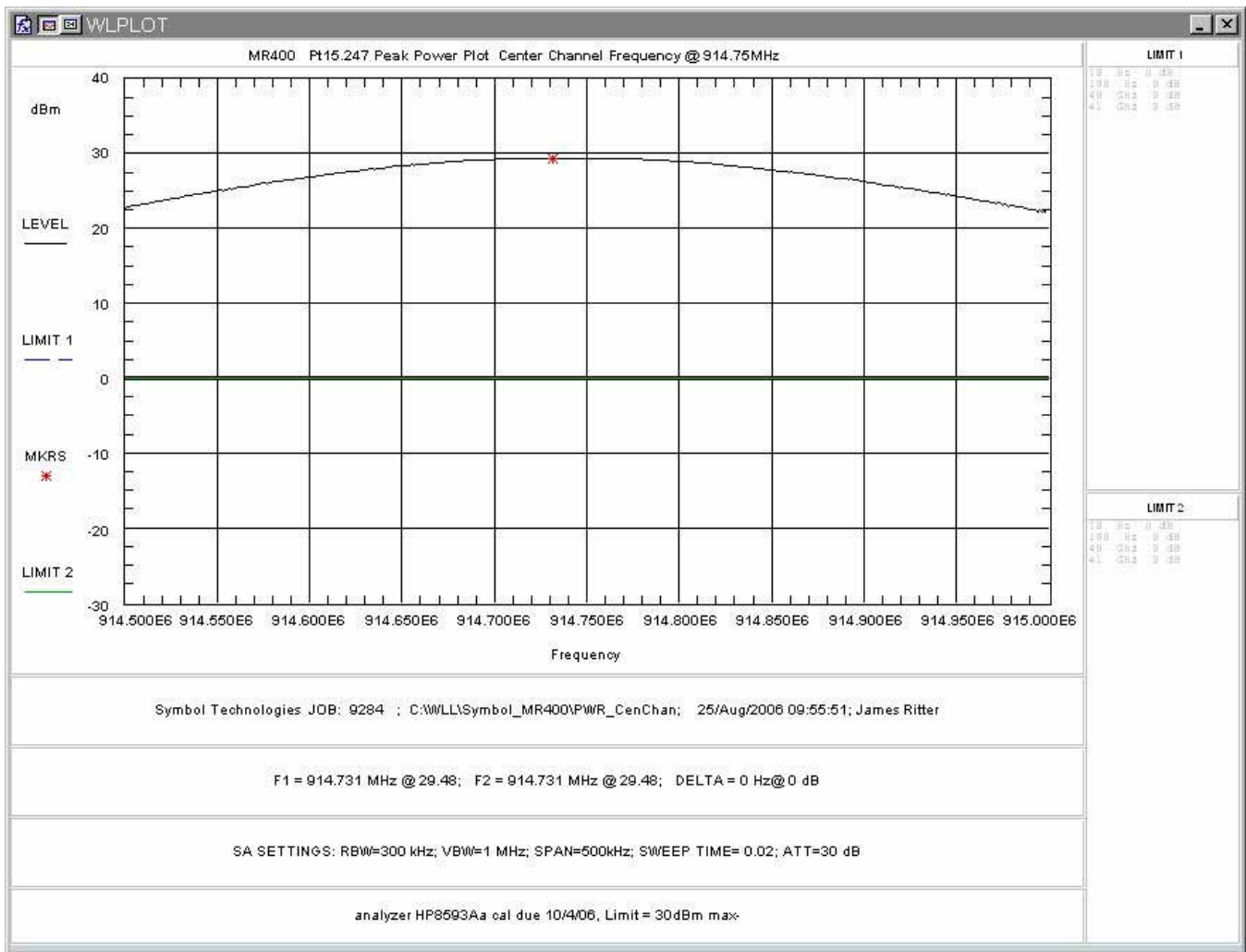

Figure 4-7. RF Peak Power (High), Mid Channel

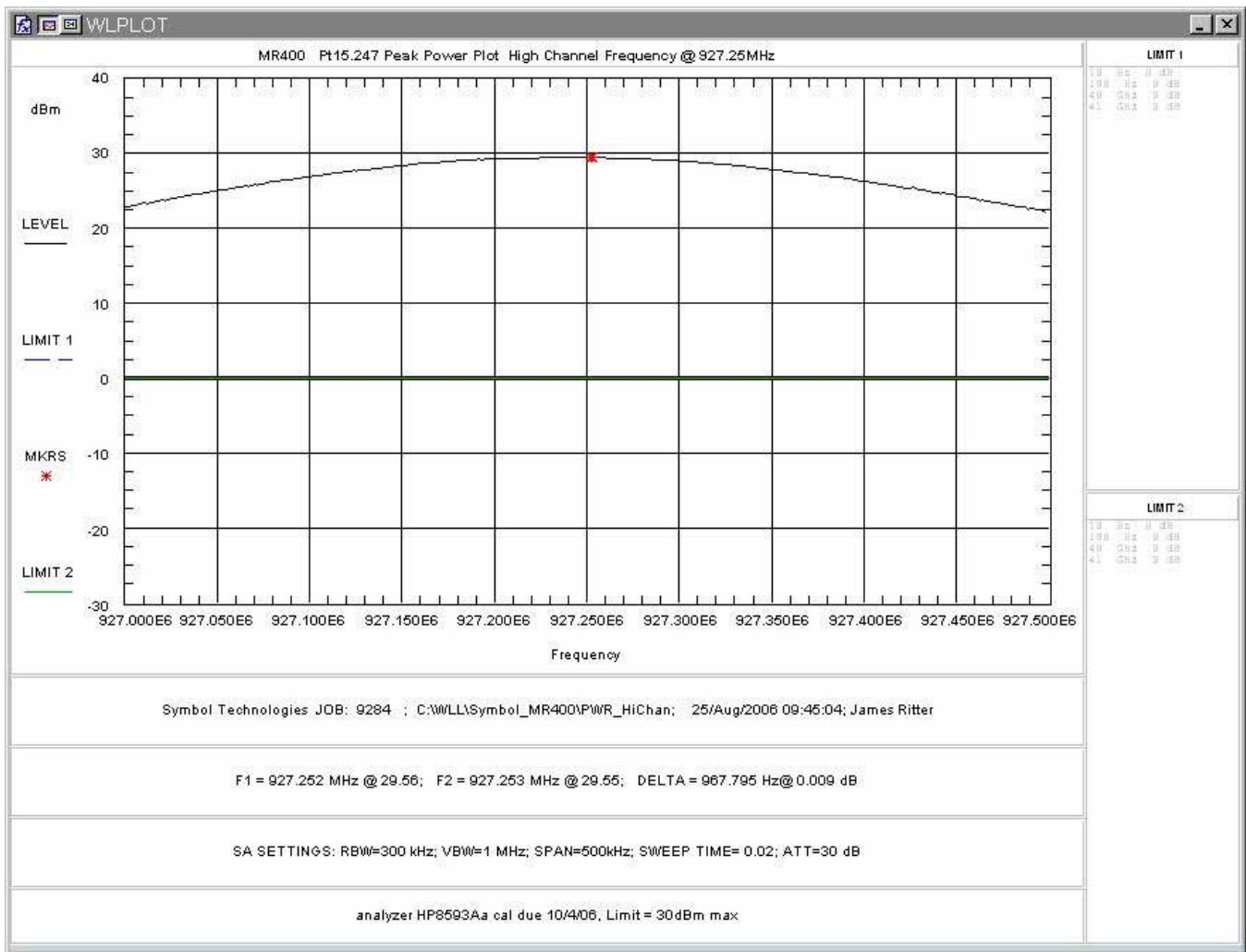

Figure 4-8. RF Peak Power (High), High Channel

### 4.3 Occupied Bandwidth: (FCC Part §2.1049)

Occupied bandwidth was performed by coupling the output of the EUT to the input of a spectrum analyzer.

For Frequency Hopping Spread Spectrum Systems, FCC Part 15.247 requires the maximum 20 dB bandwidth not exceed 1MHz.

At full modulation, the occupied bandwidth was measured as shown:

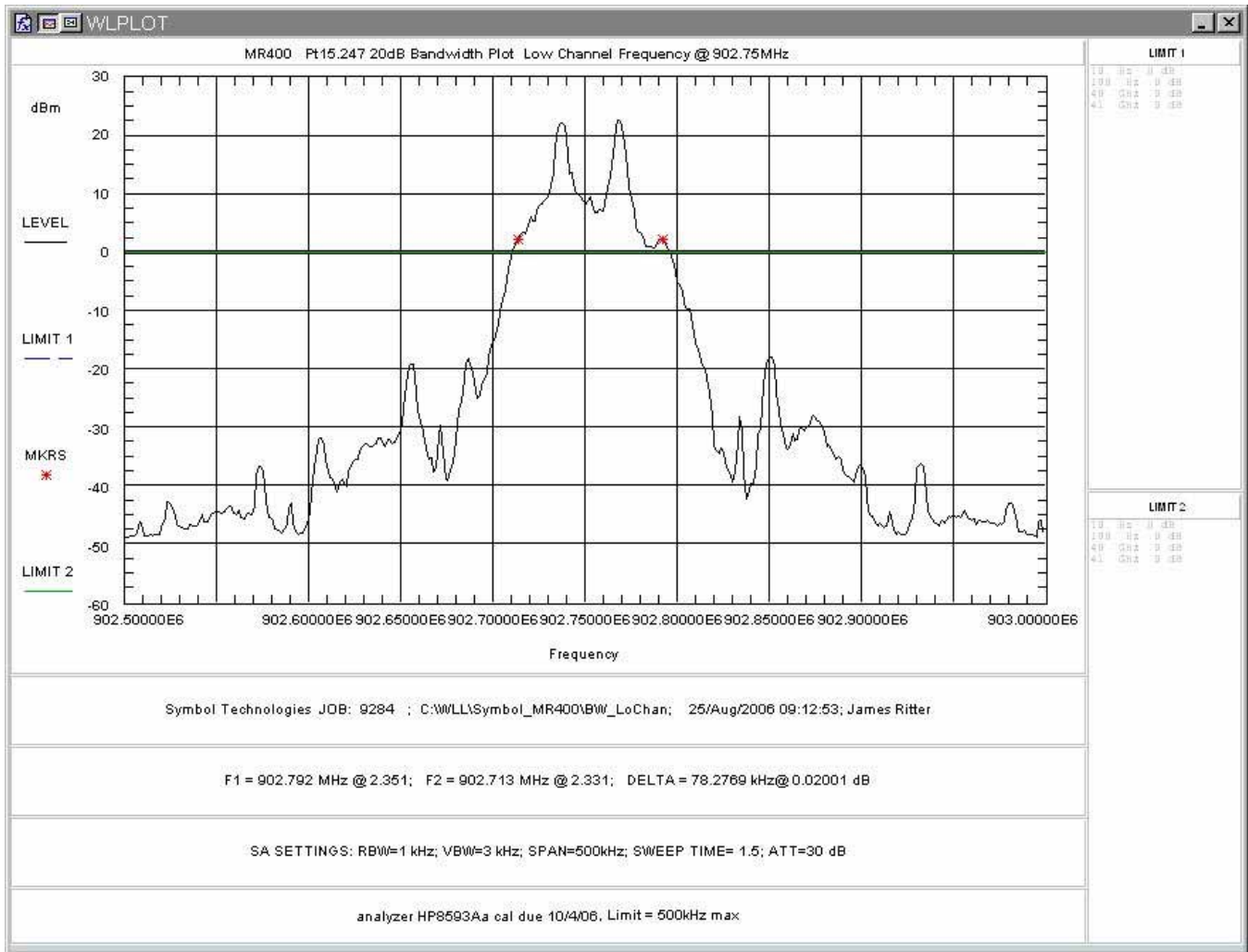

Figure 4-9. Occupied Bandwidth, Low Channel

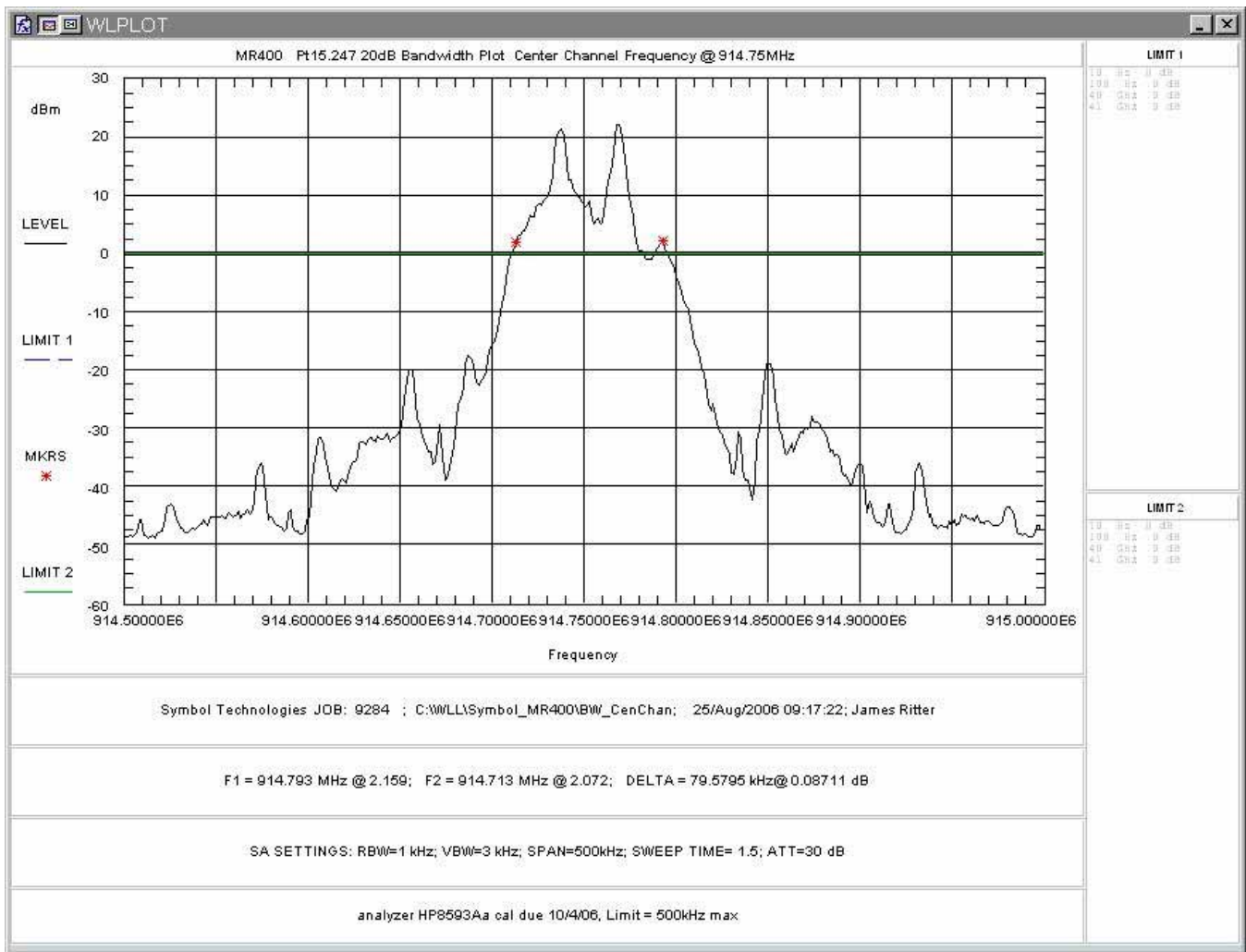
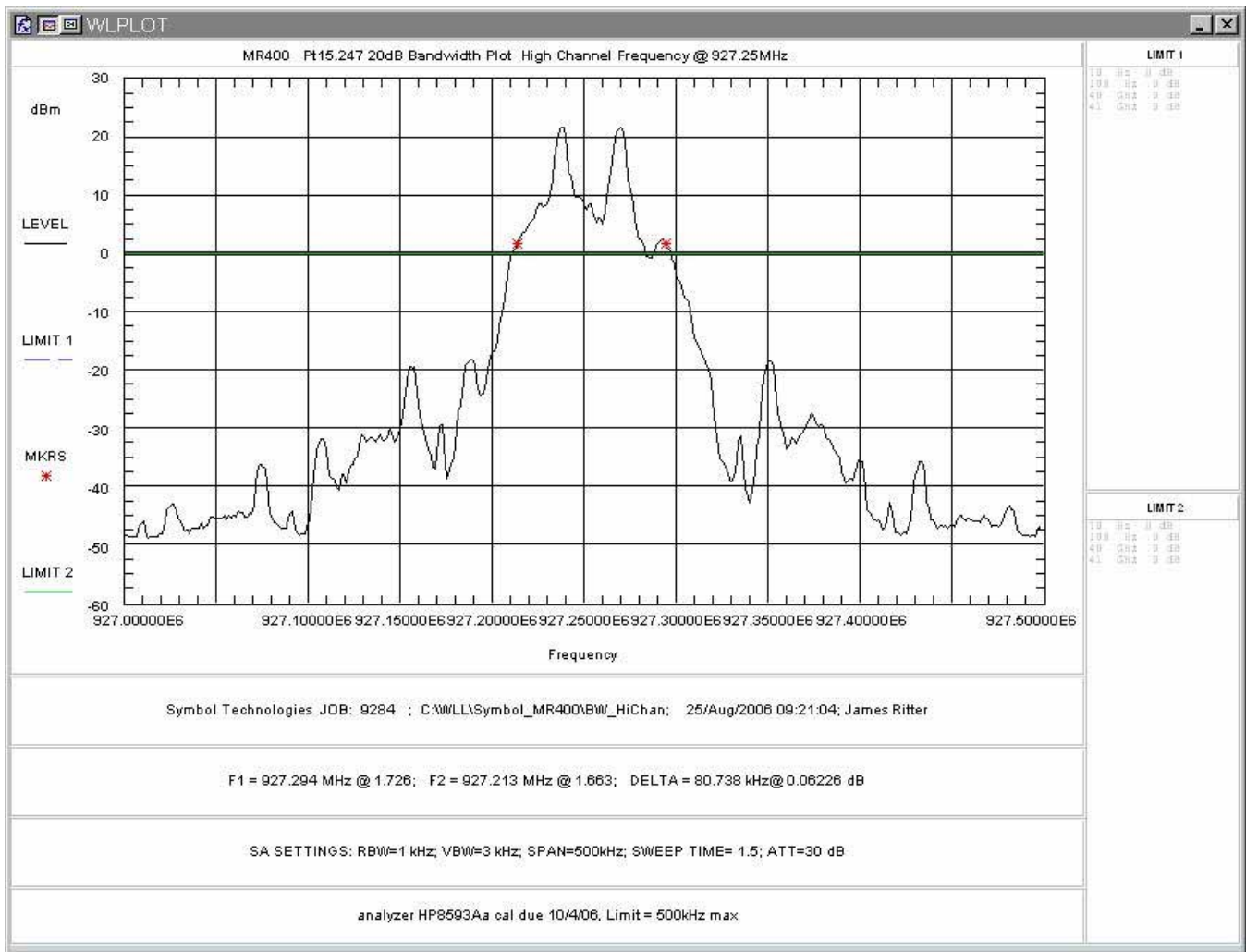

Figure 4-10. Occupied Bandwidth, Mid Channel



**Figure 4-11. Occupied Bandwidth, High Channel**

Table 5 provides a summary of the Occupied Bandwidth Results.

**Table 5. Occupied Bandwidth Results**

Frequency	Bandwidth	Limit	Pass/Fail
Low Channel 902.75MHz	78.276kHz	1 MHz	Pass
Mid Channel 914.75MHz	79.579kHz	1 MHz	Pass
High Channel 927.25MHz	80.738kHz	1 MHz	Pass

#### **4.4 Channel Spacing and Number of Hop Channels (FCC Part §15247(a)(1))**

Per the FCC requirements, frequency hopping systems shall have hopping channel carrier frequencies separated by a minimum of 25kHz or the 20 dB bandwidth, whichever is greater. The maximum 20dB bandwidth measured is 80.738kHz. The EUT antenna was removed and the cable was connected directly into a spectrum analyzer through a 10 dB attenuator. An offset was programmed into the spectrum analyzer to compensate for the loss of the external attenuator. The spectrum analyzer resolution bandwidth was set to 100 kHz and the video bandwidth was set to 100 kHz.

The following are plots of the channel spacing and number of hopping channels data. The channel spacing was measured to be 500.6kHz and the number of channels used is 50.



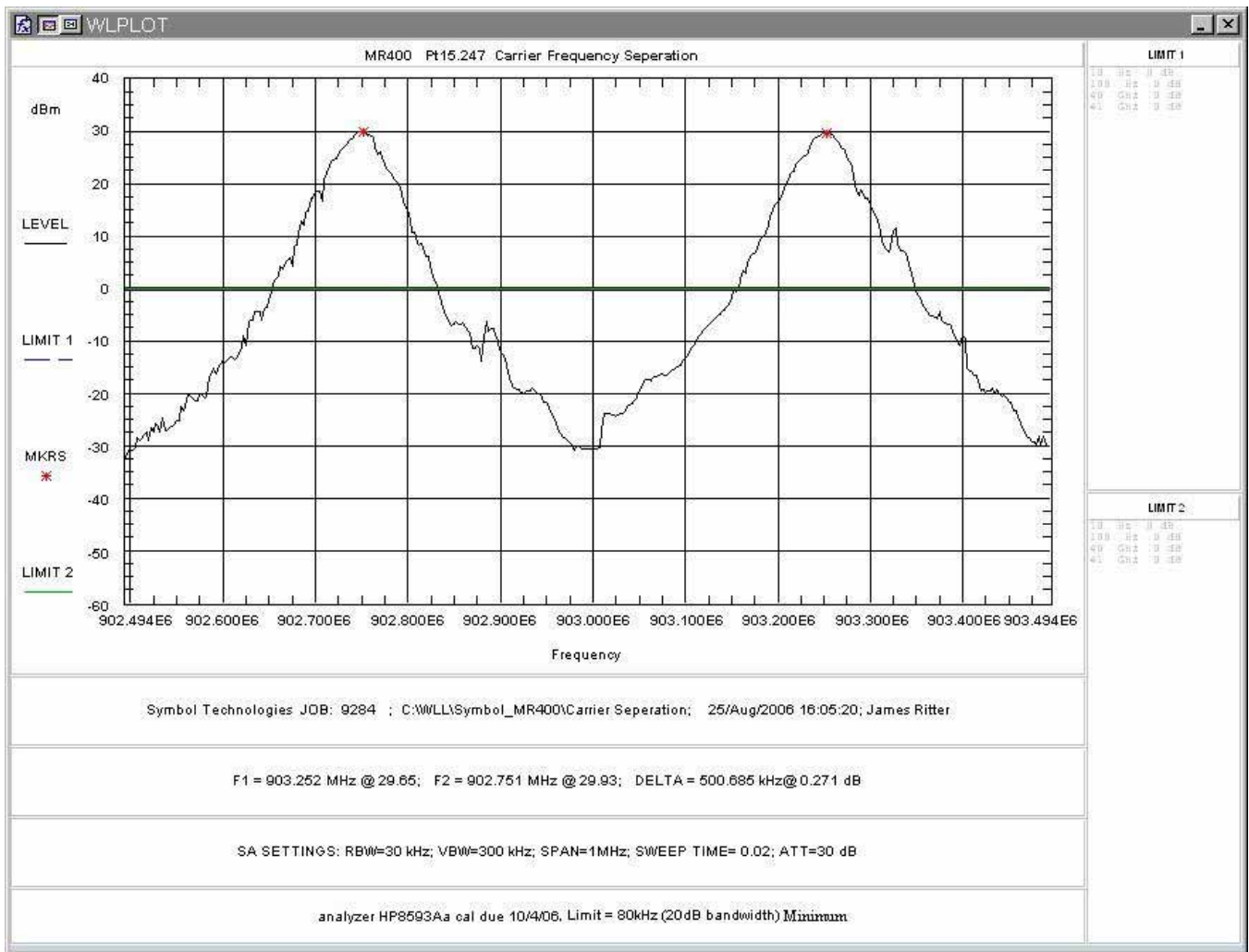

Figure 4-12. Channel Spacing, 500kHz

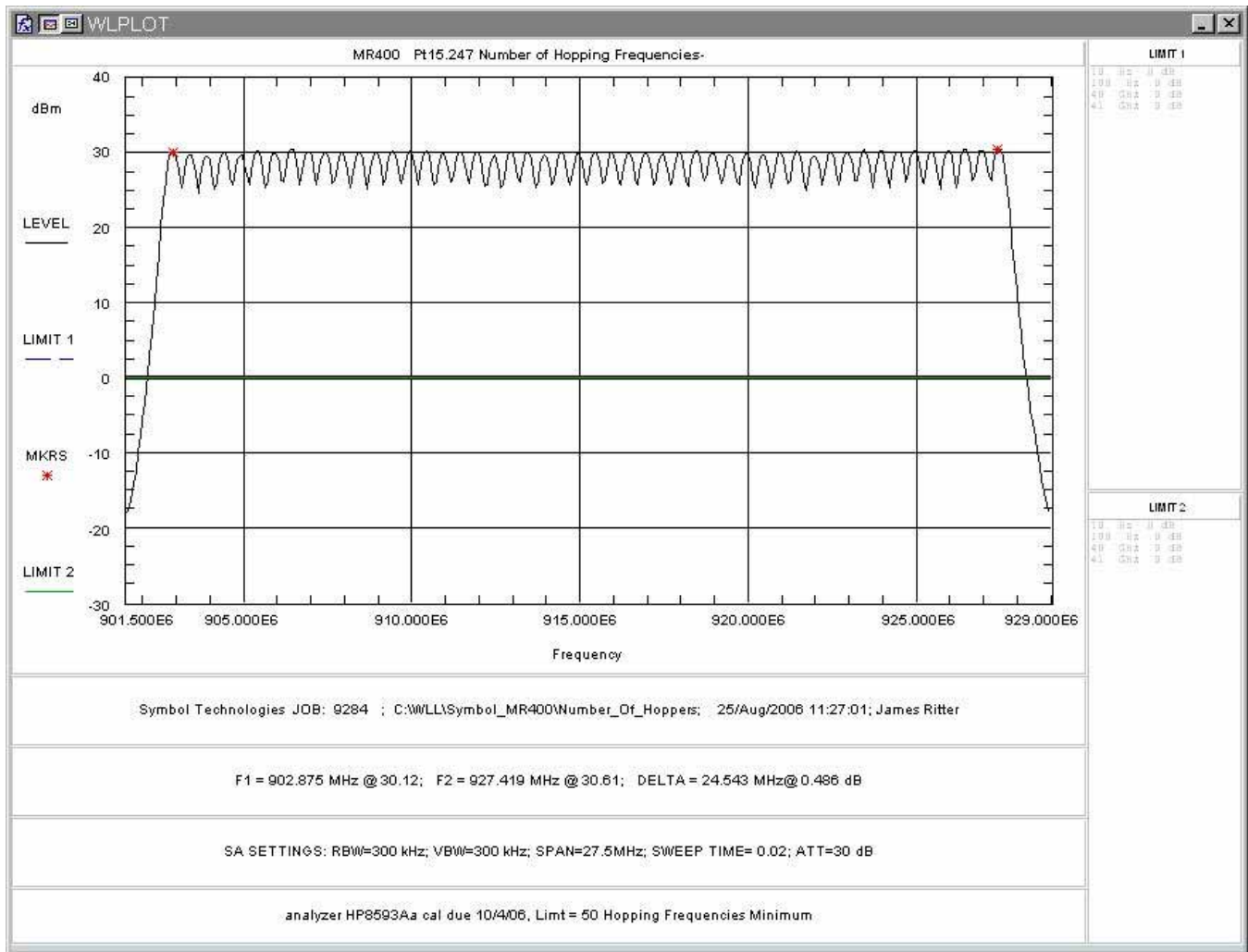

Figure 4-13. Number of Channels

#### **4.5 Conducted Spurious Emissions at Antenna Terminals (FCC Part §2.1051)**

The EUT must comply with requirements for spurious emissions at antenna terminals. Per §15.247(c) all spurious emissions in any 100 kHz bandwidth outside the frequency band in which the spread spectrum device is operating shall be attenuated 20 dB below the highest power level in a 100 kHz bandwidth within the band containing the highest level of the desired power.

The EUT antenna was removed and the cable was connected directly into a spectrum analyzer through a 10 dB attenuator. An offset was programmed into the spectrum analyzer to compensate for the loss of the external attenuator. The spectrum analyzer resolution bandwidth was set to 100 kHz and the video bandwidth was set to 100 kHz. The amplitude of the EUT carrier frequency was measured to determine the emissions limit (20 dB below the carrier frequency amplitude). The emissions outside of the allocated frequency band were then scanned from 30 MHz up to the tenth harmonic of the carrier.

Conducted spurious emissions testing was performed in the DH1 mode for the high channel, DH3 mode for the middle channel, and DH5 mode for the low channel with the hopping disabled. Additionally, the bandedge conducted emissions testing was performed with the hopping activated and with the hopping stopped.

The following are plots of the conducted spurious emissions data. Bandedge plots are shown in Figure 4-38 through Figure 4-43.

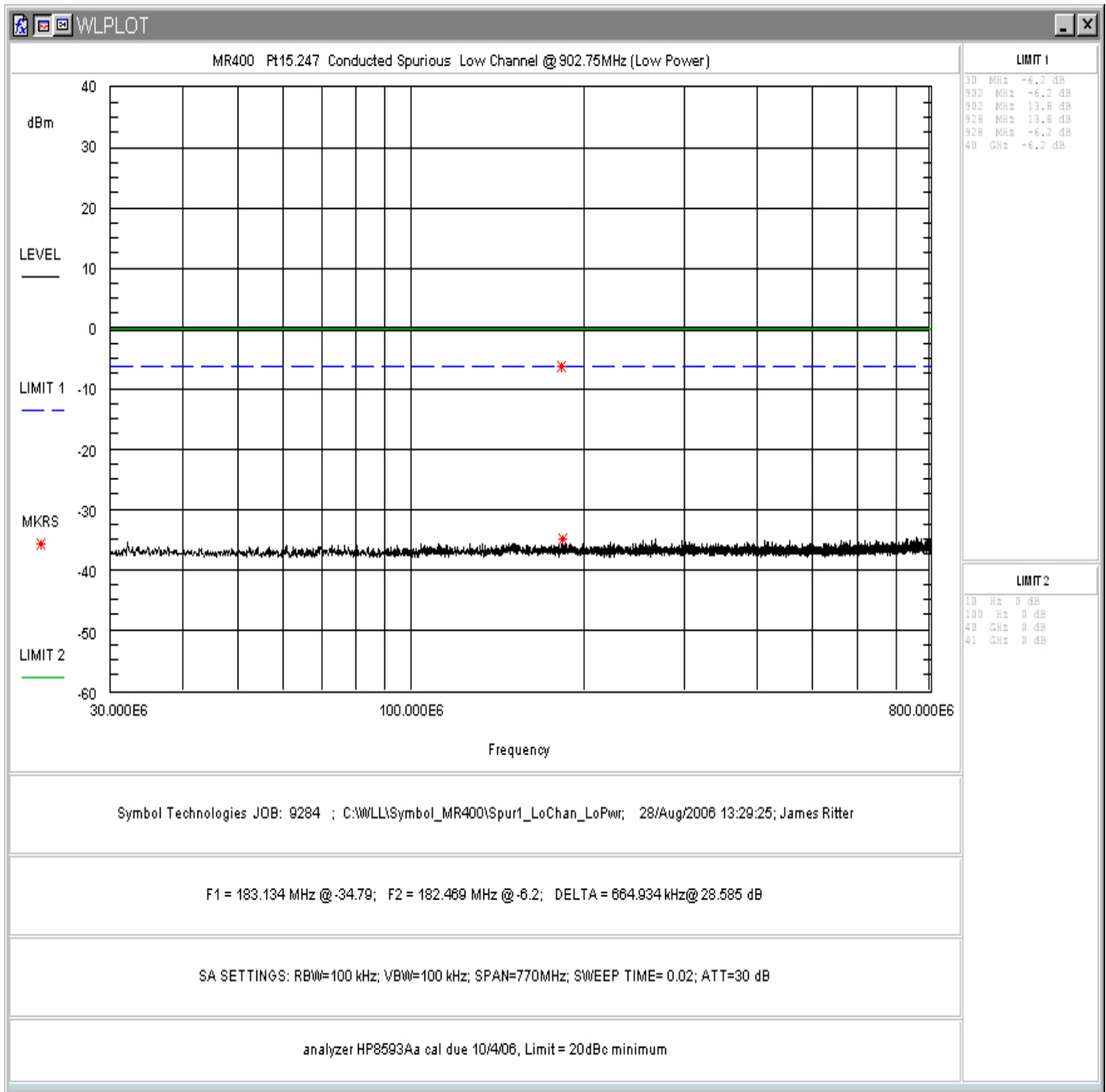

Figure 4-14. Conducted Spurious Emissions (Low Power), Low Channel 30 - 800MHz

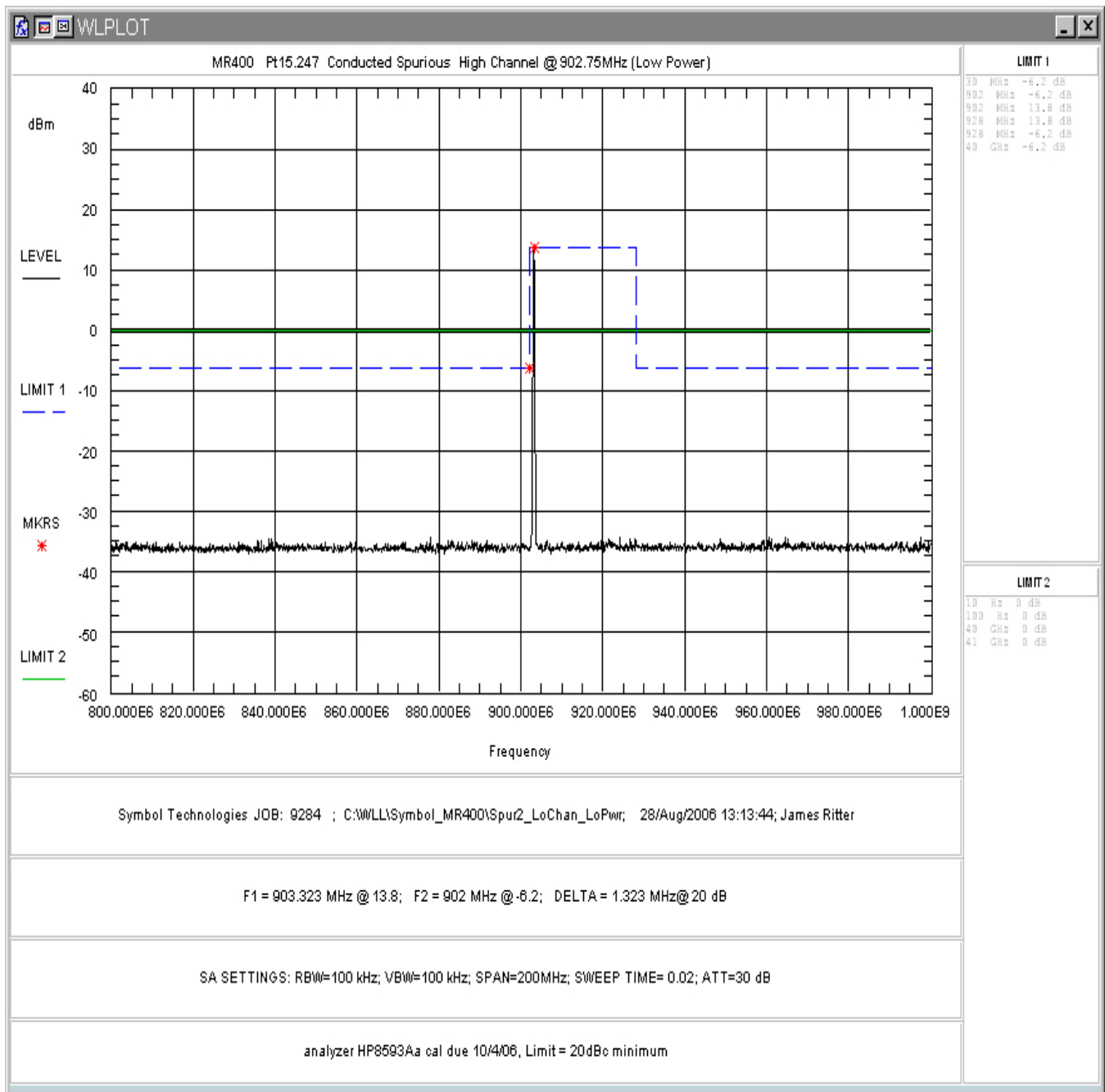

Figure 4-15. Conducted Spurious Emissions (Low Power), Low Channel 800 – 1000MHz

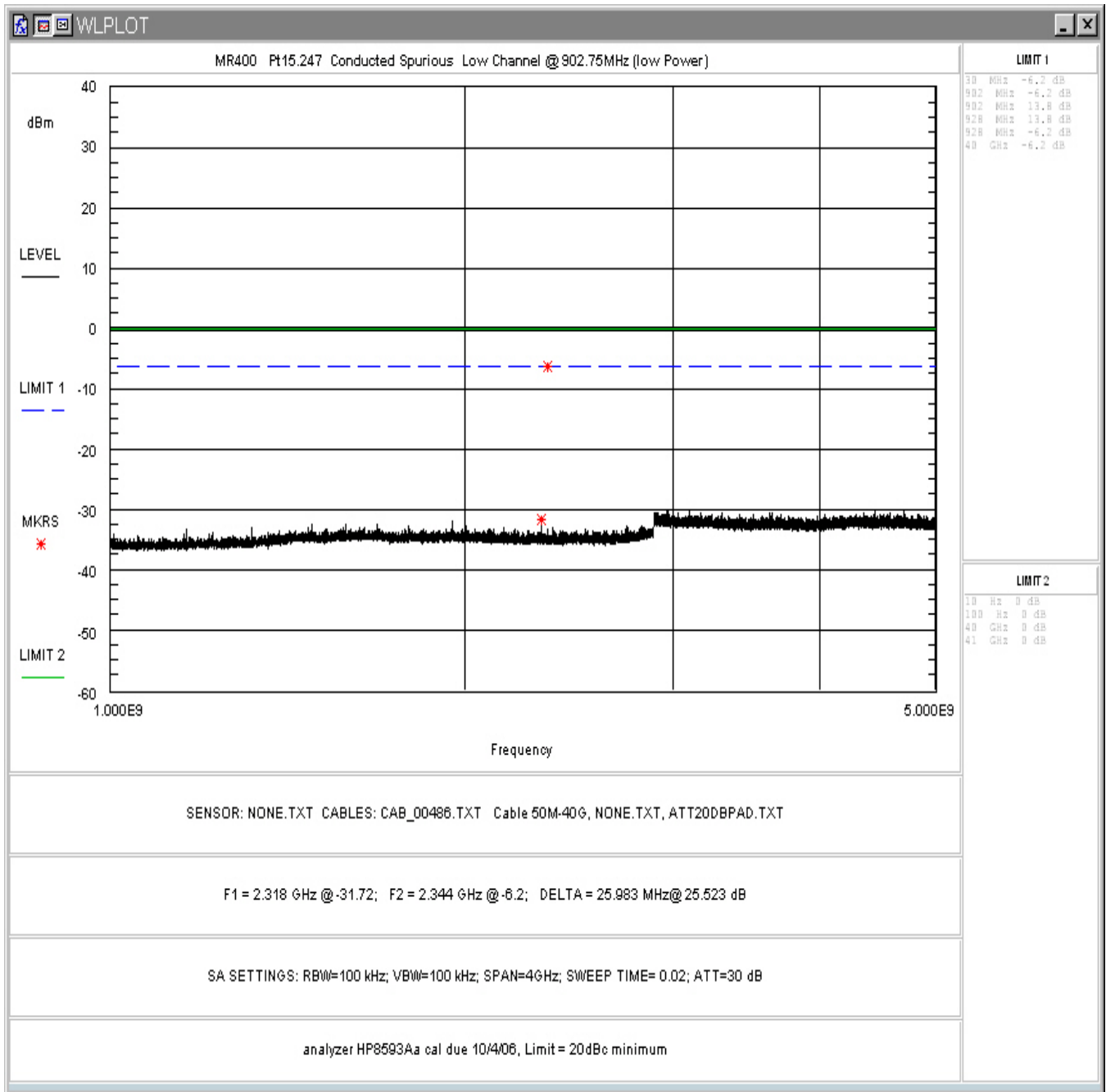

Figure 4-16. Conducted Spurious Emissions (Low Power), Low Channel 1 -5GHz

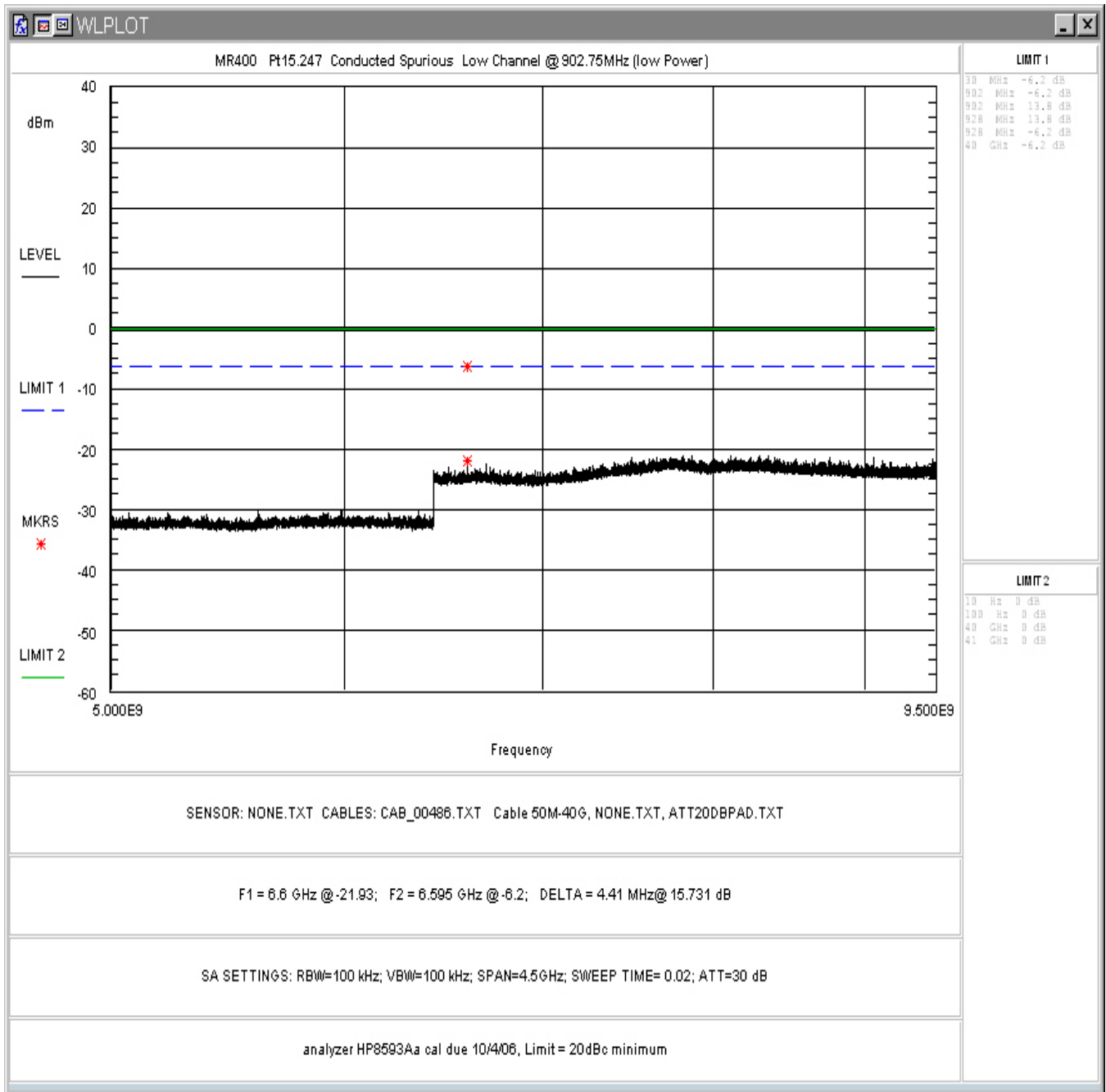

Figure 4-17. Conducted Spurious Emissions (Low Power), Low Channel 5 – 9.5GHz

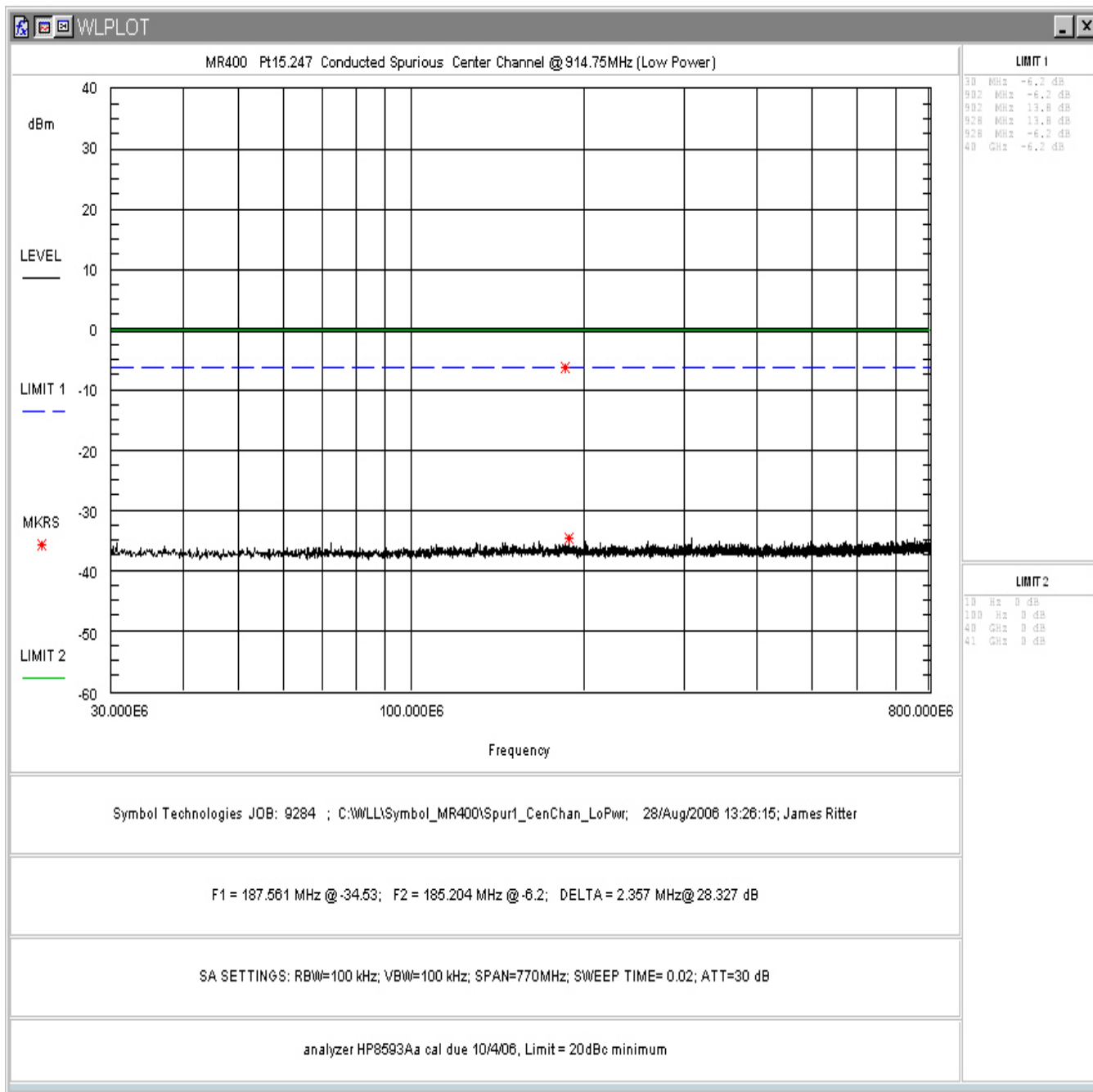

Figure 4-18. Conducted Spurious Emissions (Low Power), Mid Channel 30 - 800MHz



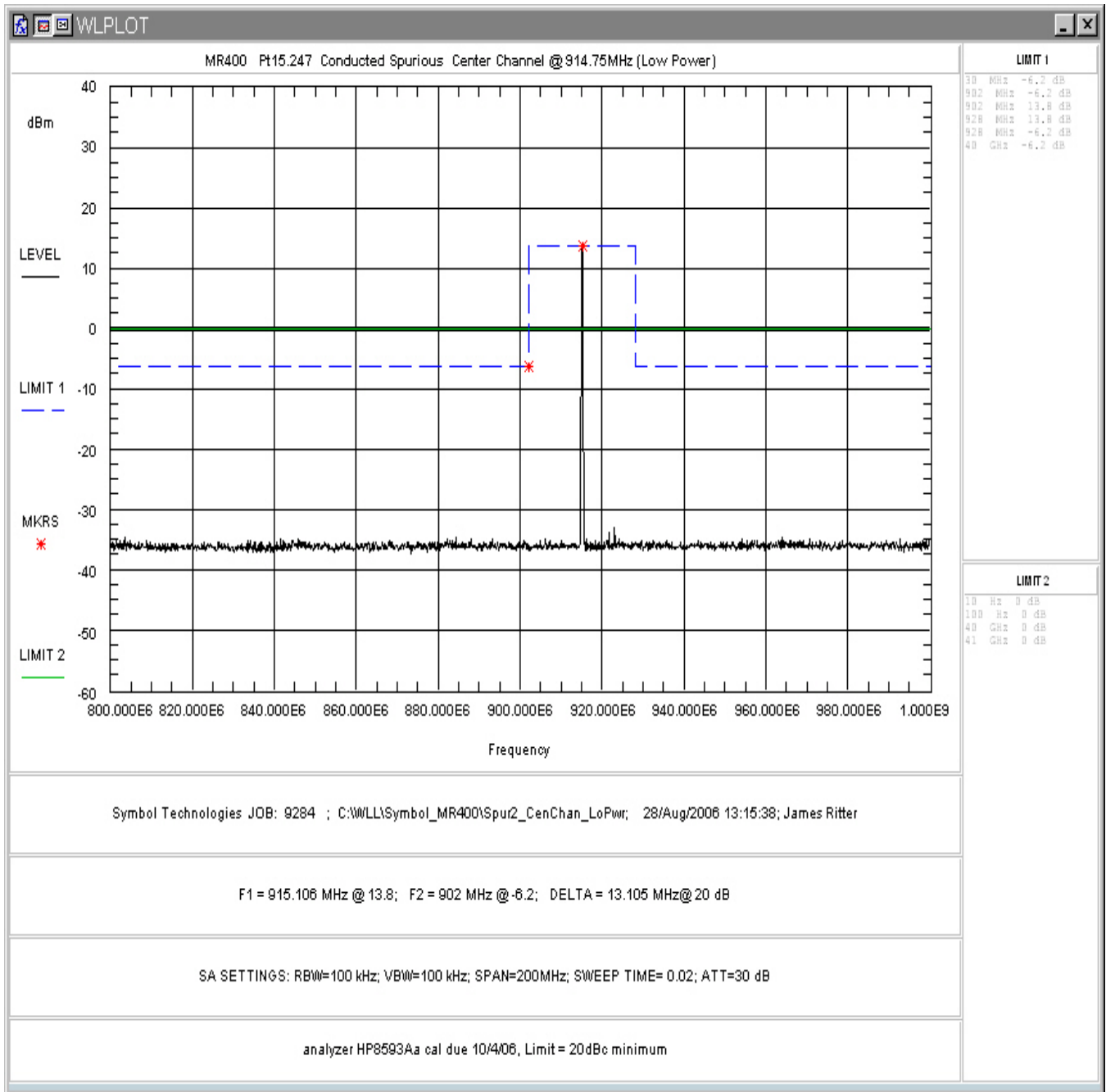

Figure 4-19. Conducted Spurious Emissions (Low Power), Mid Channel 800 – 1000MHz

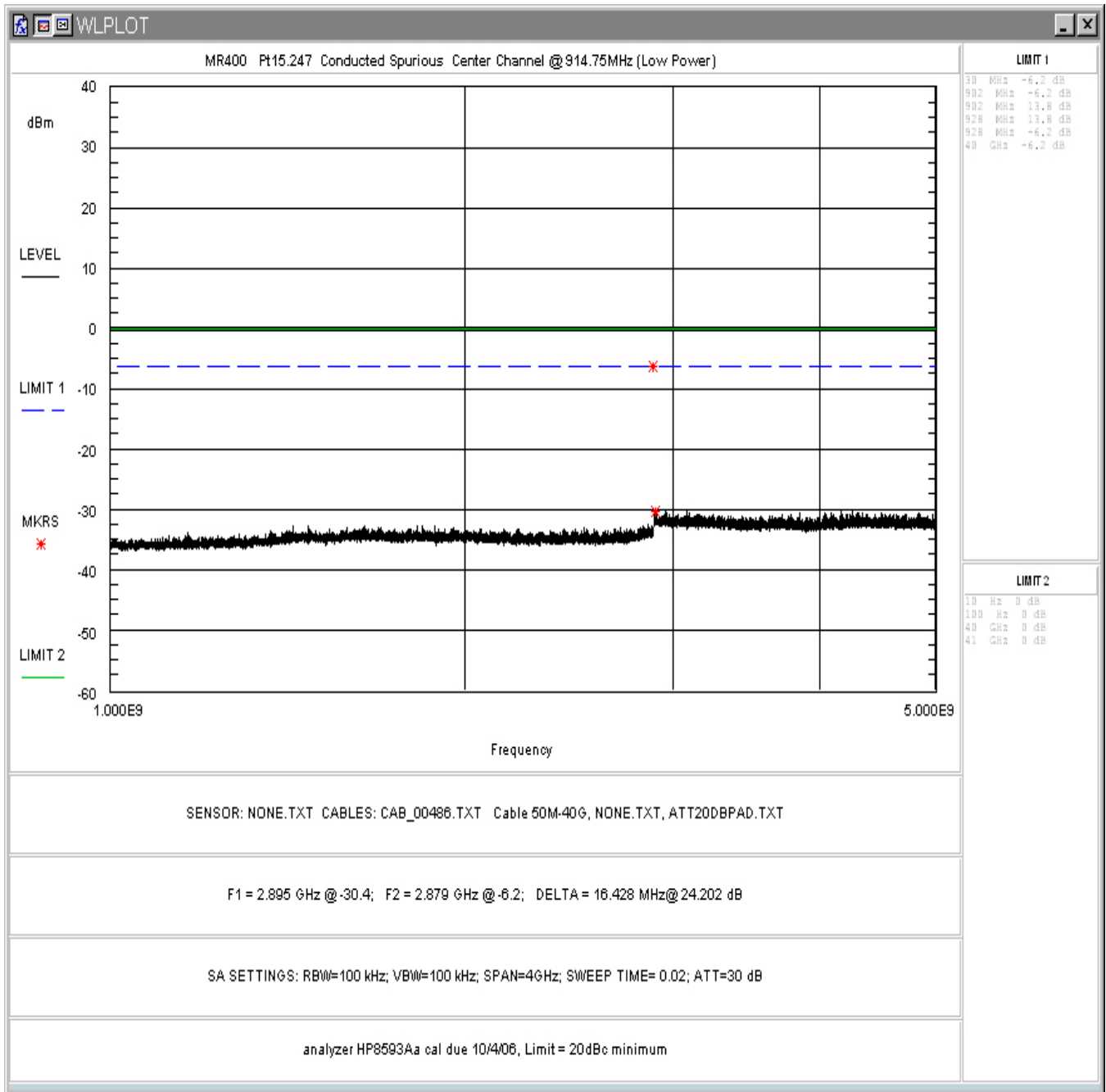

Figure 4-20. Conducted Spurious Emissions (Low Power), Mid Channel 1 -5GHz

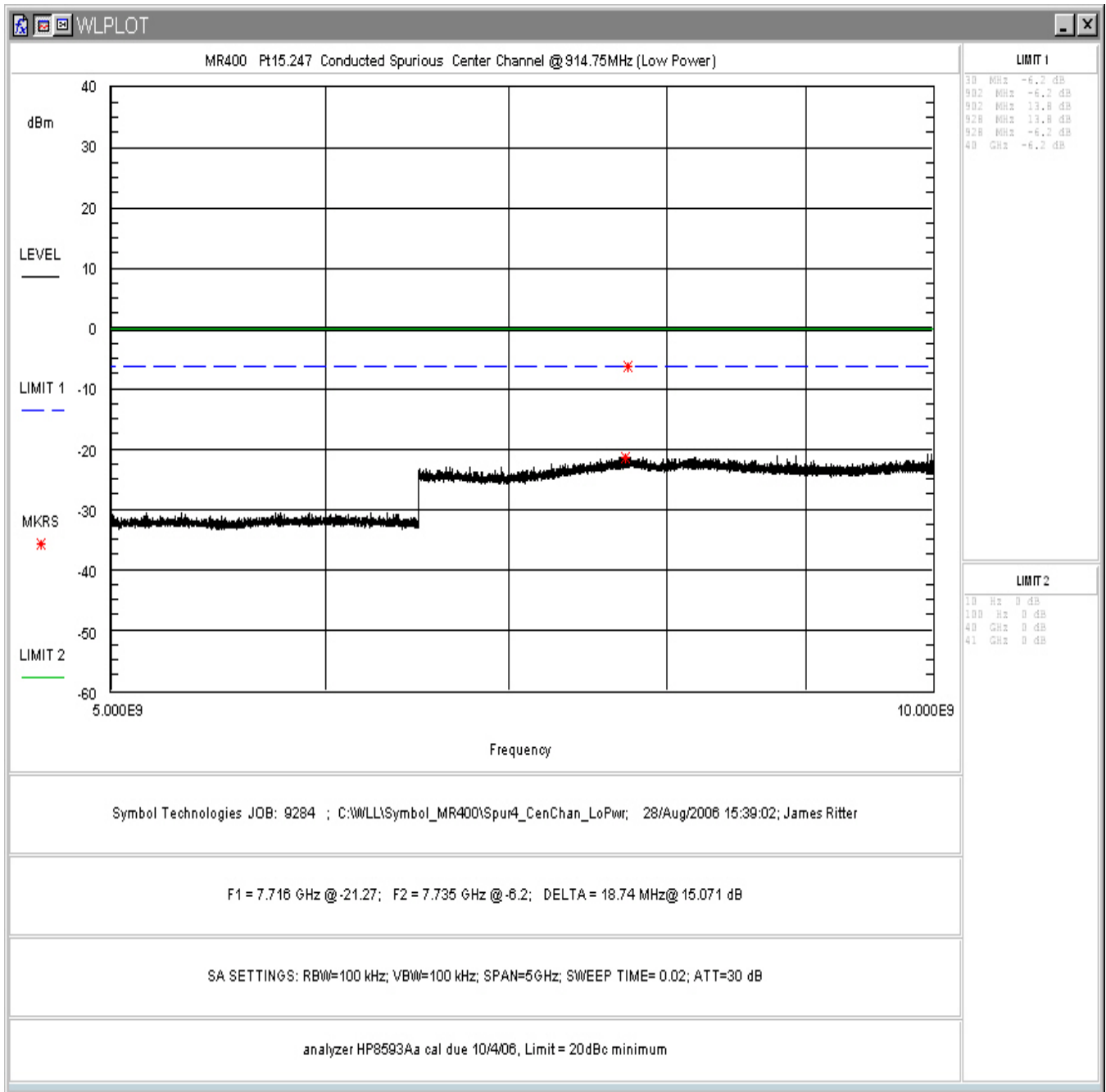

Figure 4-21. Conducted Spurious Emissions (Low Power), Mid Channel 5 – 9.5GHz

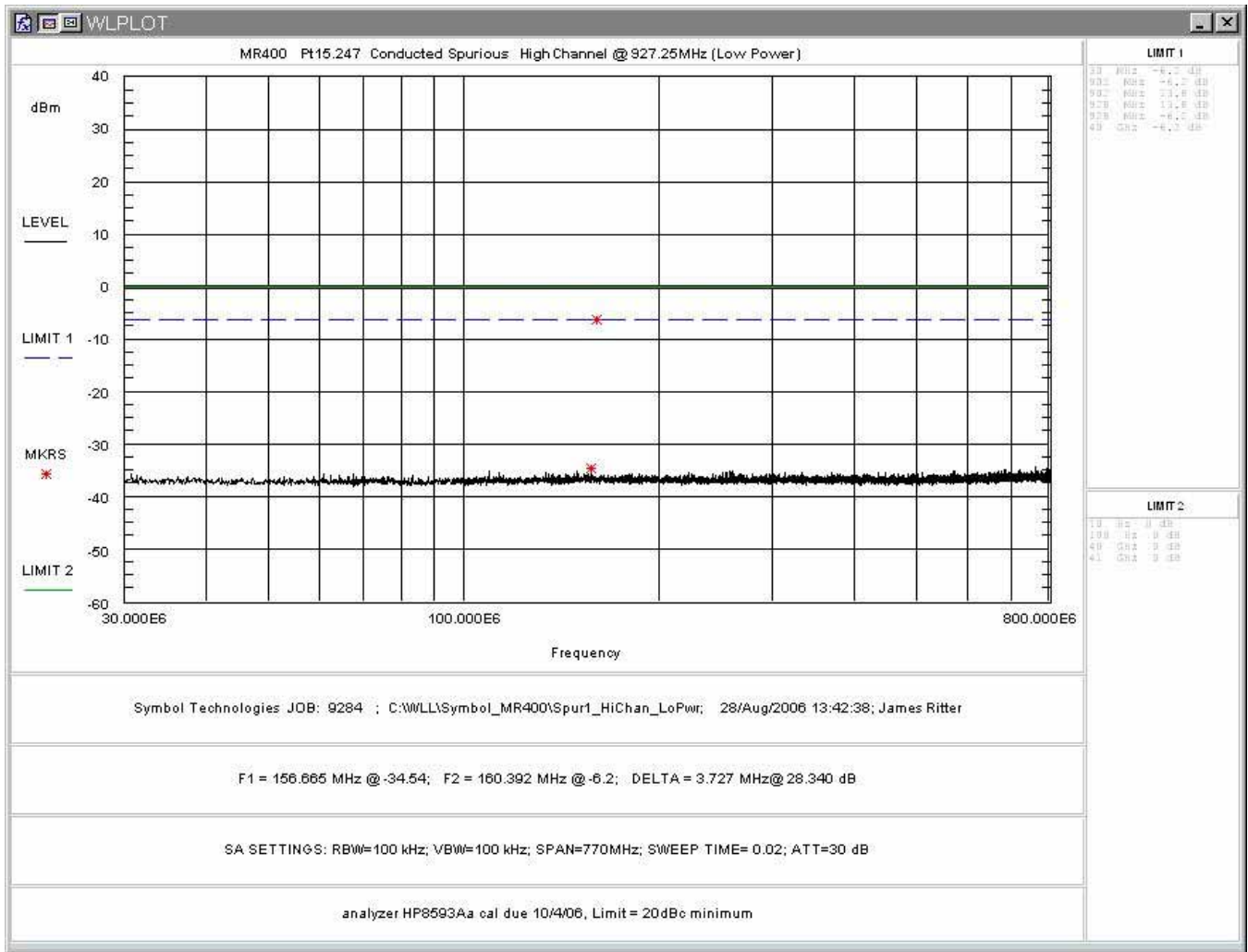

Figure 4-22. Conducted Spurious Emissions (Low Power), High Channel 30 - 800MHz

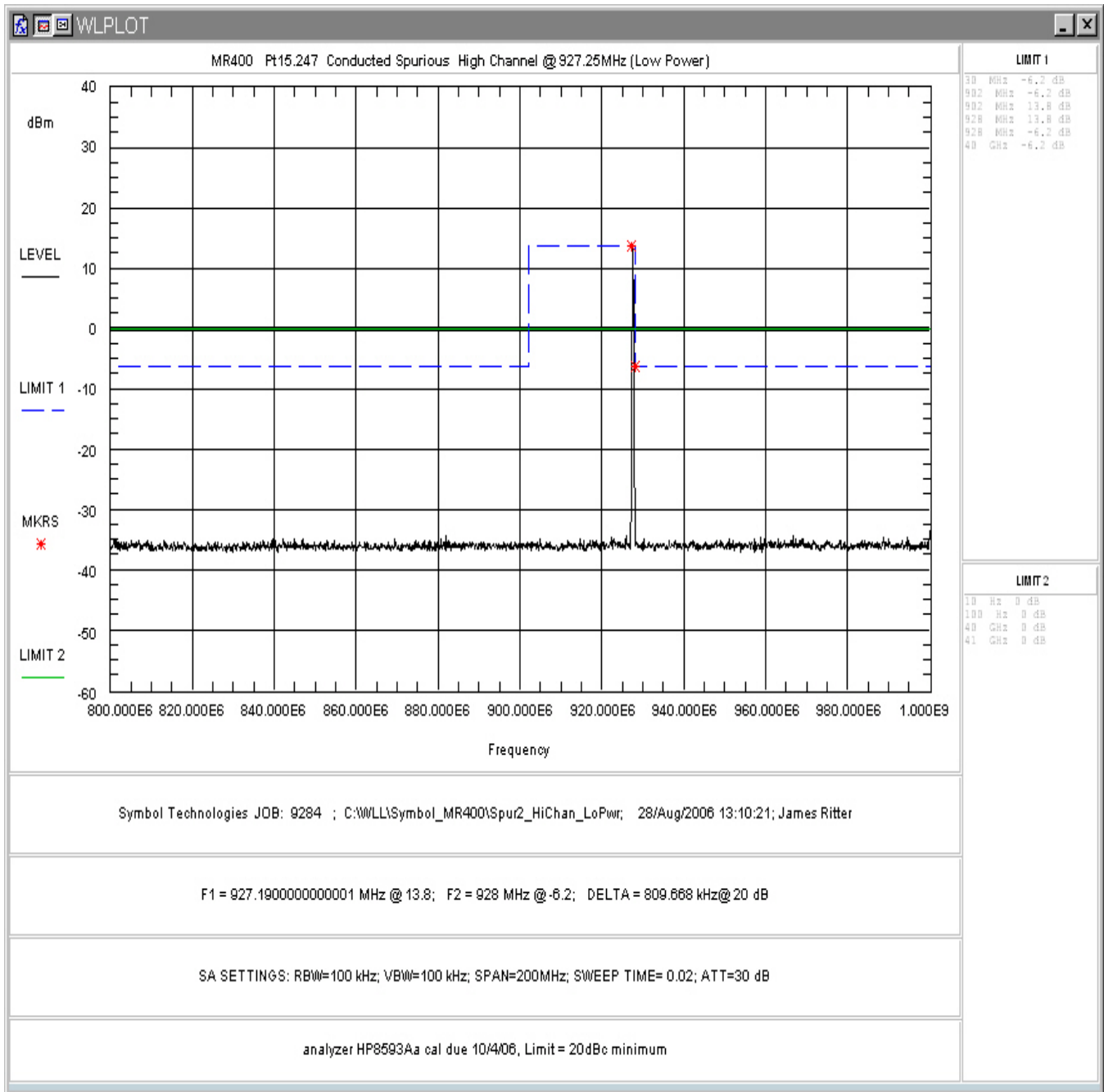

Figure 4-23. Conducted Spurious Emissions (Low Power), High Channel 800 – 1000MHz

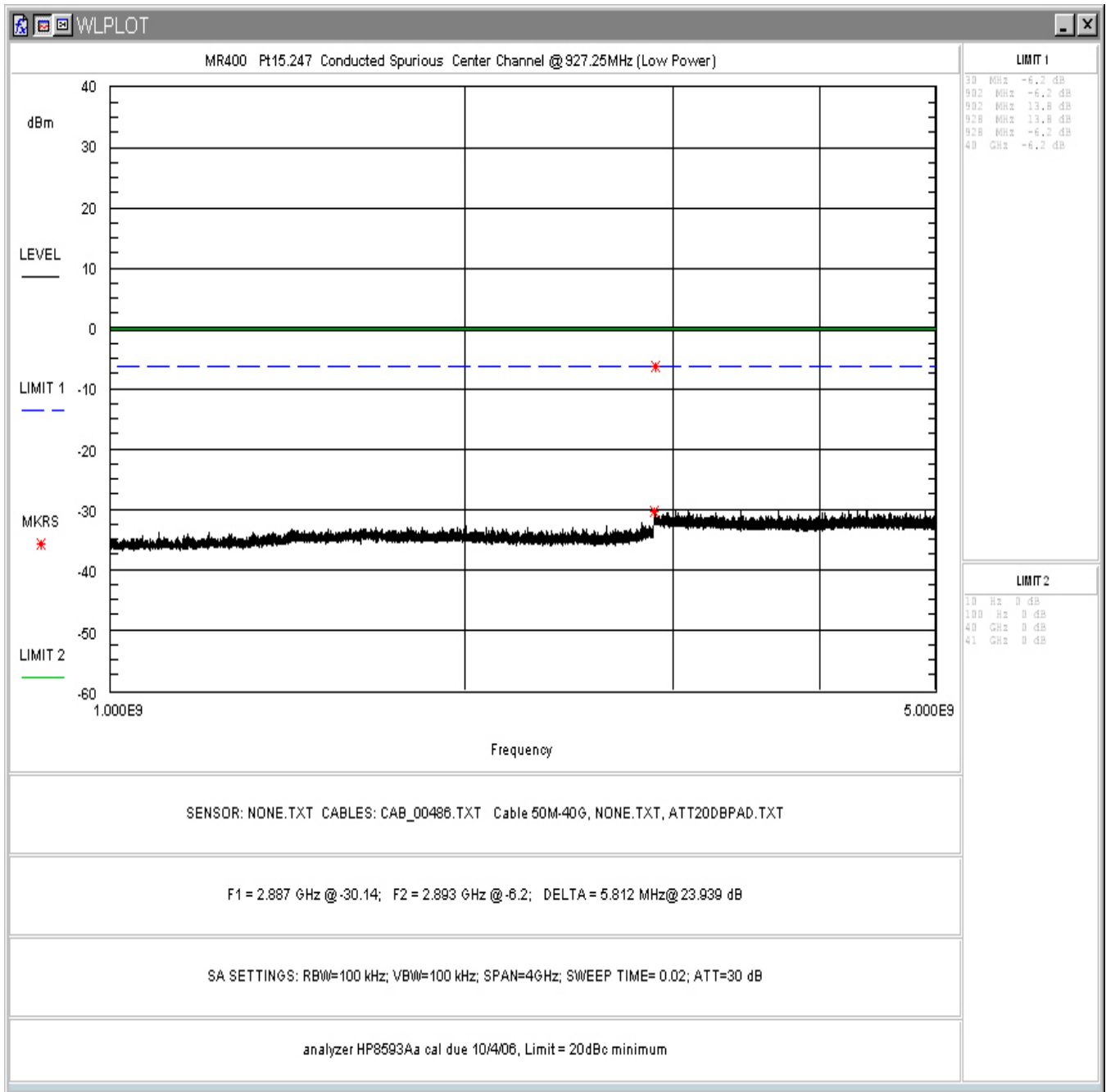

Figure 4-24. Conducted Spurious Emissions (Low Power), High Channel 1 –5GHz

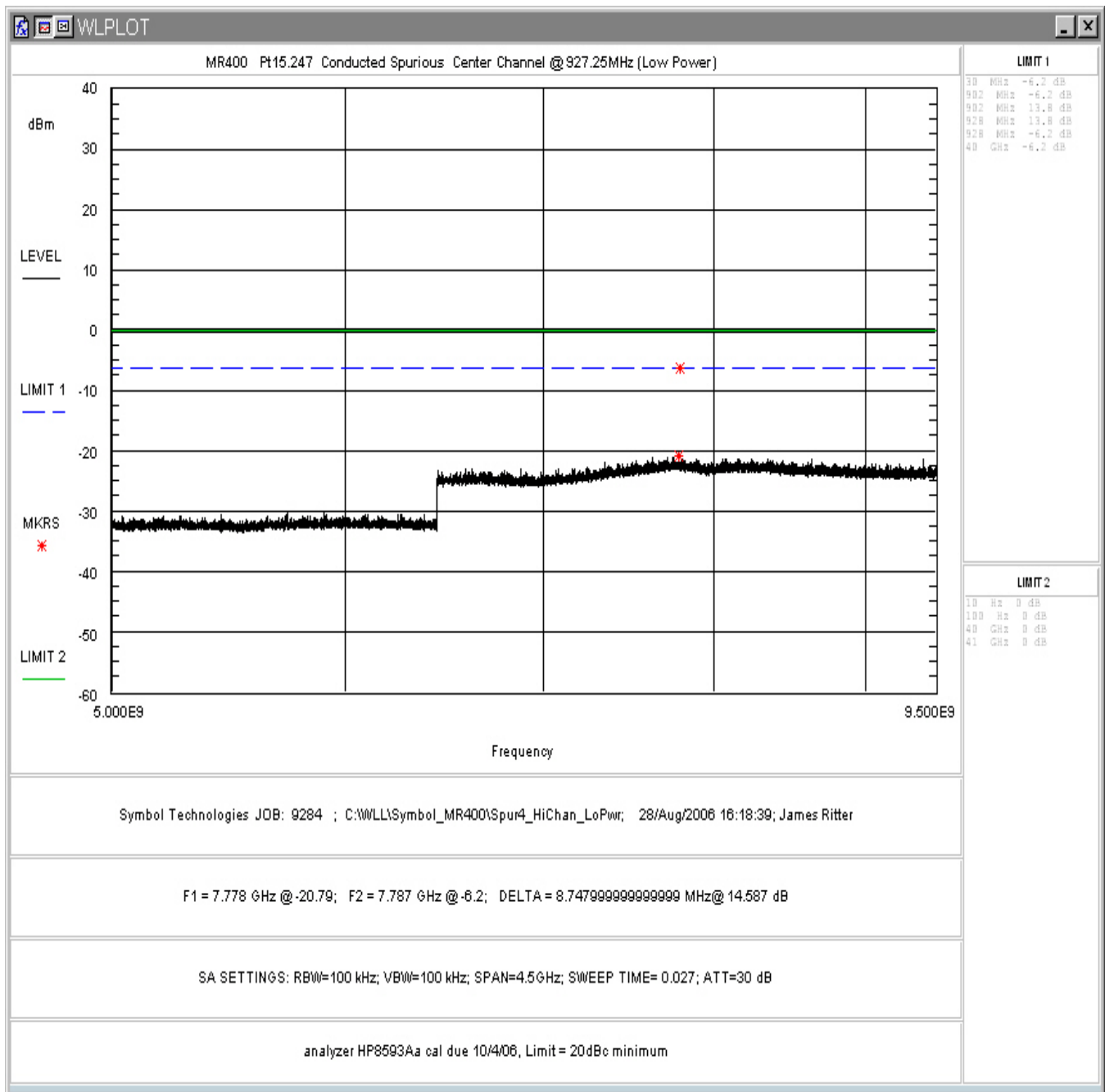

Figure 4-25. Conducted Spurious Emissions (Low Power), High Channel 5 – 9.5GHz

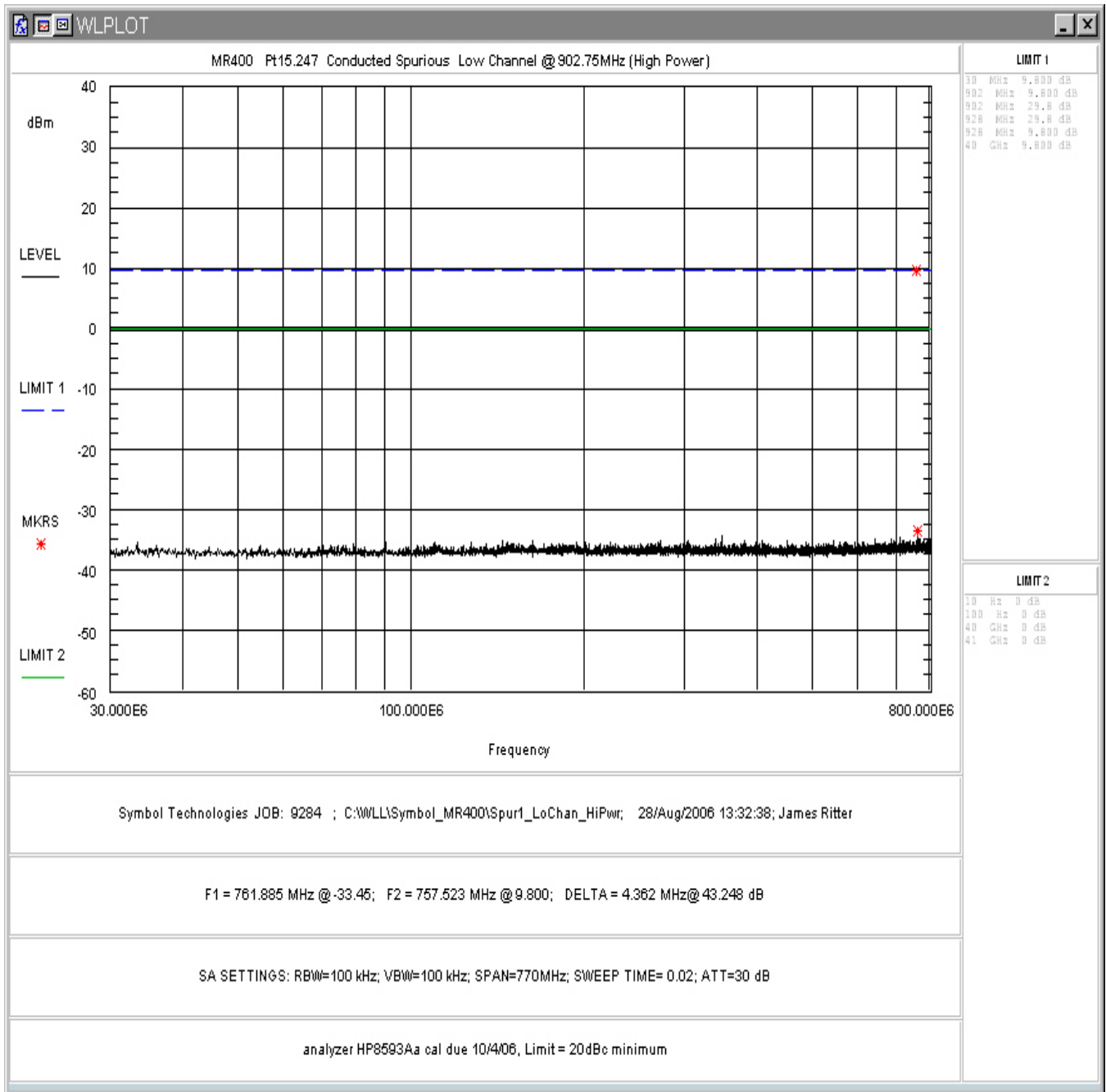

Figure 4-26. Conducted Spurious Emissions (High Power), Low Channel 30 - 800MHz



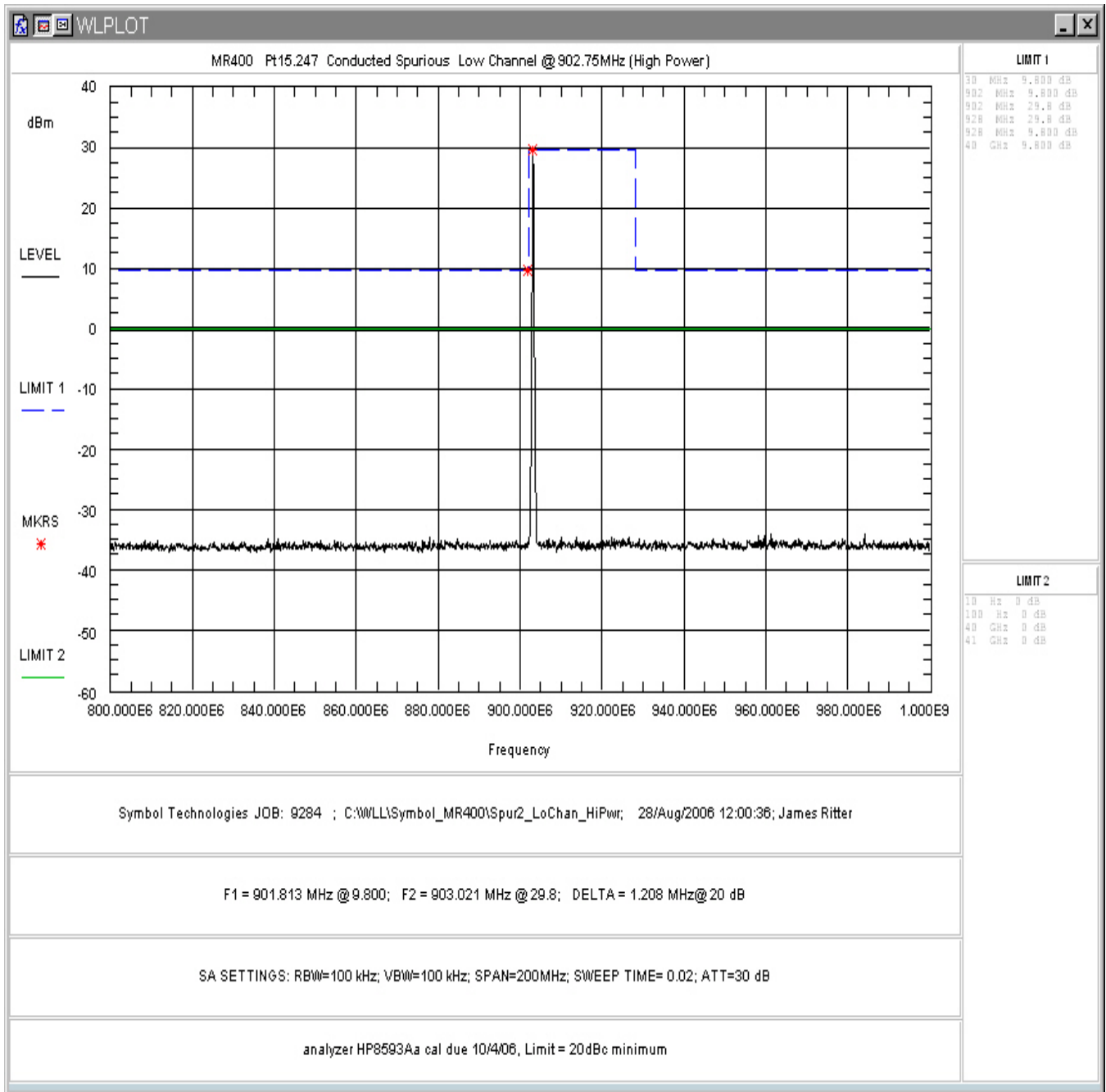

Figure 4-27. Conducted Spurious Emissions (High Power), Low Channel 800 – 1000MHz

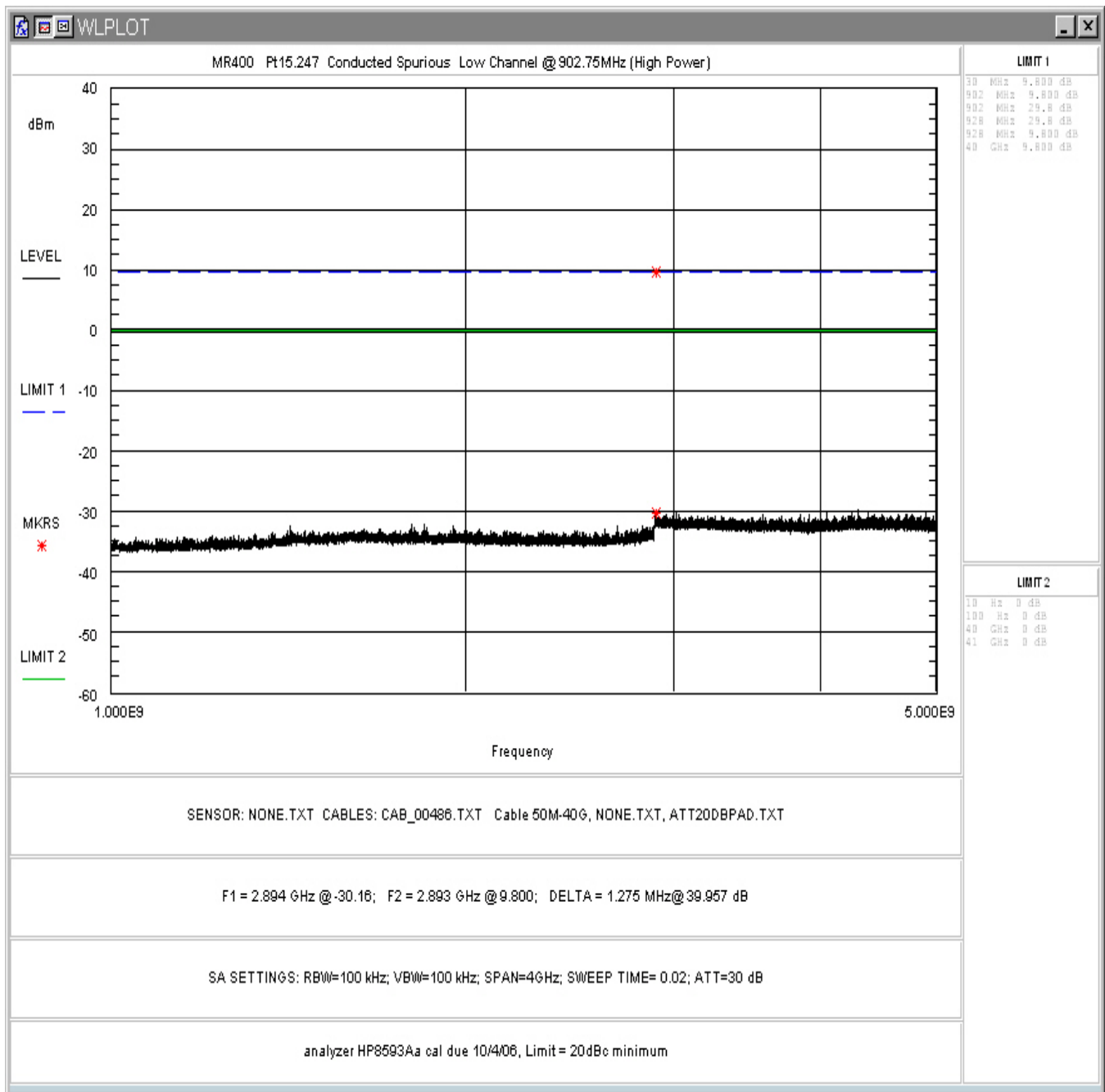

Figure 4-28. Conducted Spurious Emissions (High Power), Low Channel 1 –5GHz

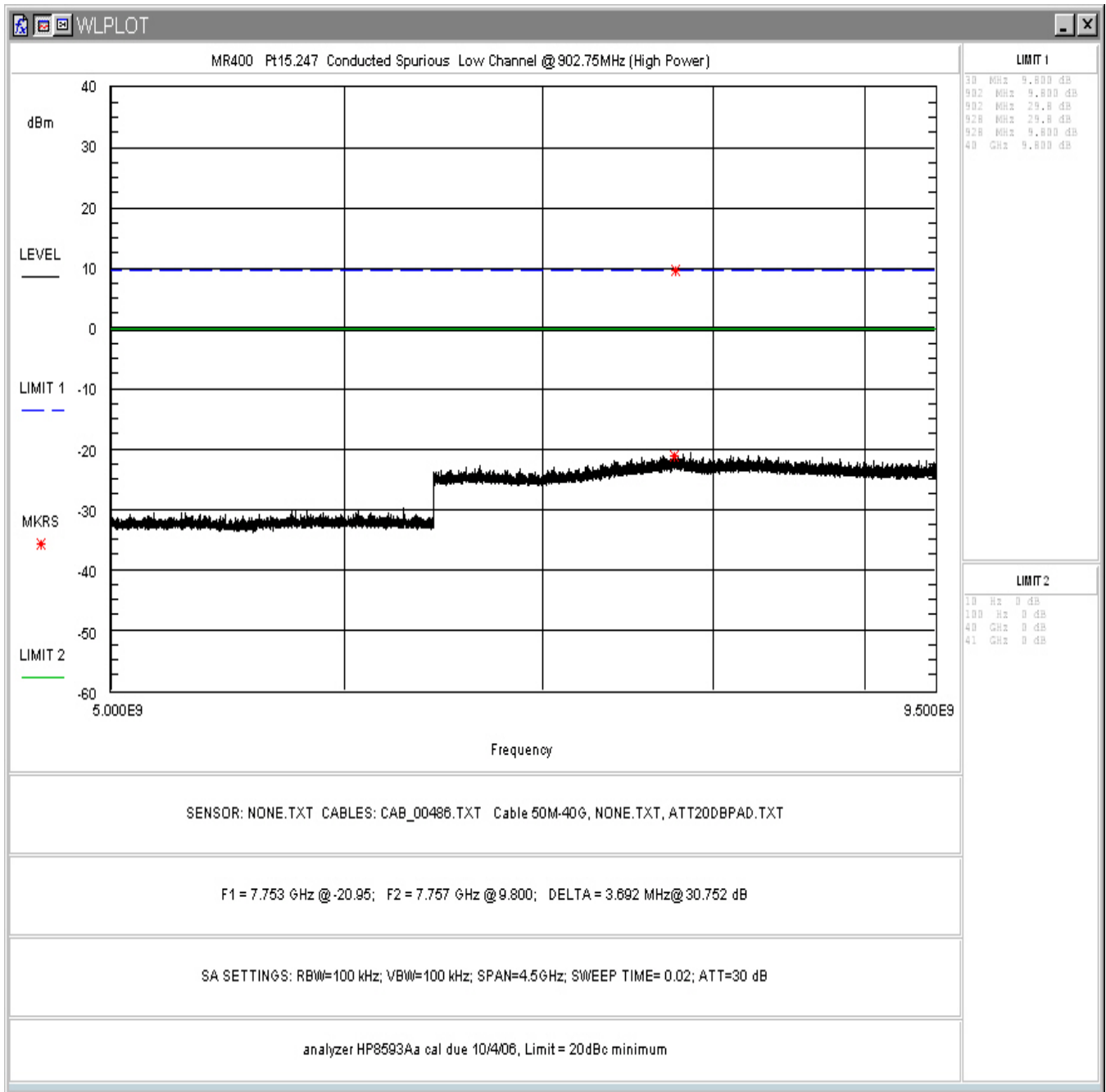

Figure 4-29. Conducted Spurious Emissions (High Power), Low Channel 5 – 9.5GHz

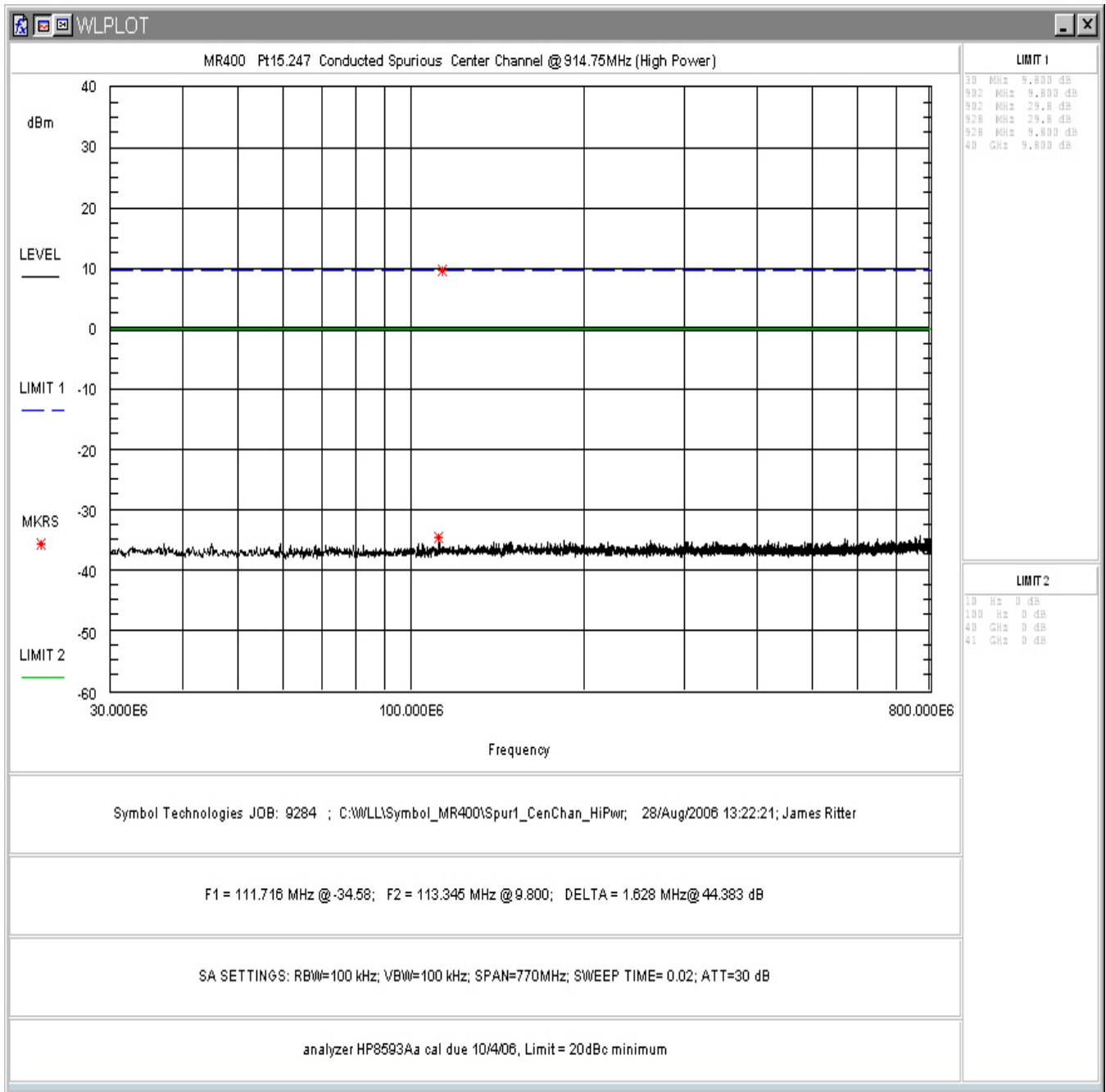

Figure 4-30. Conducted Spurious Emissions (High Power), Mid Channel 30 - 800MHz

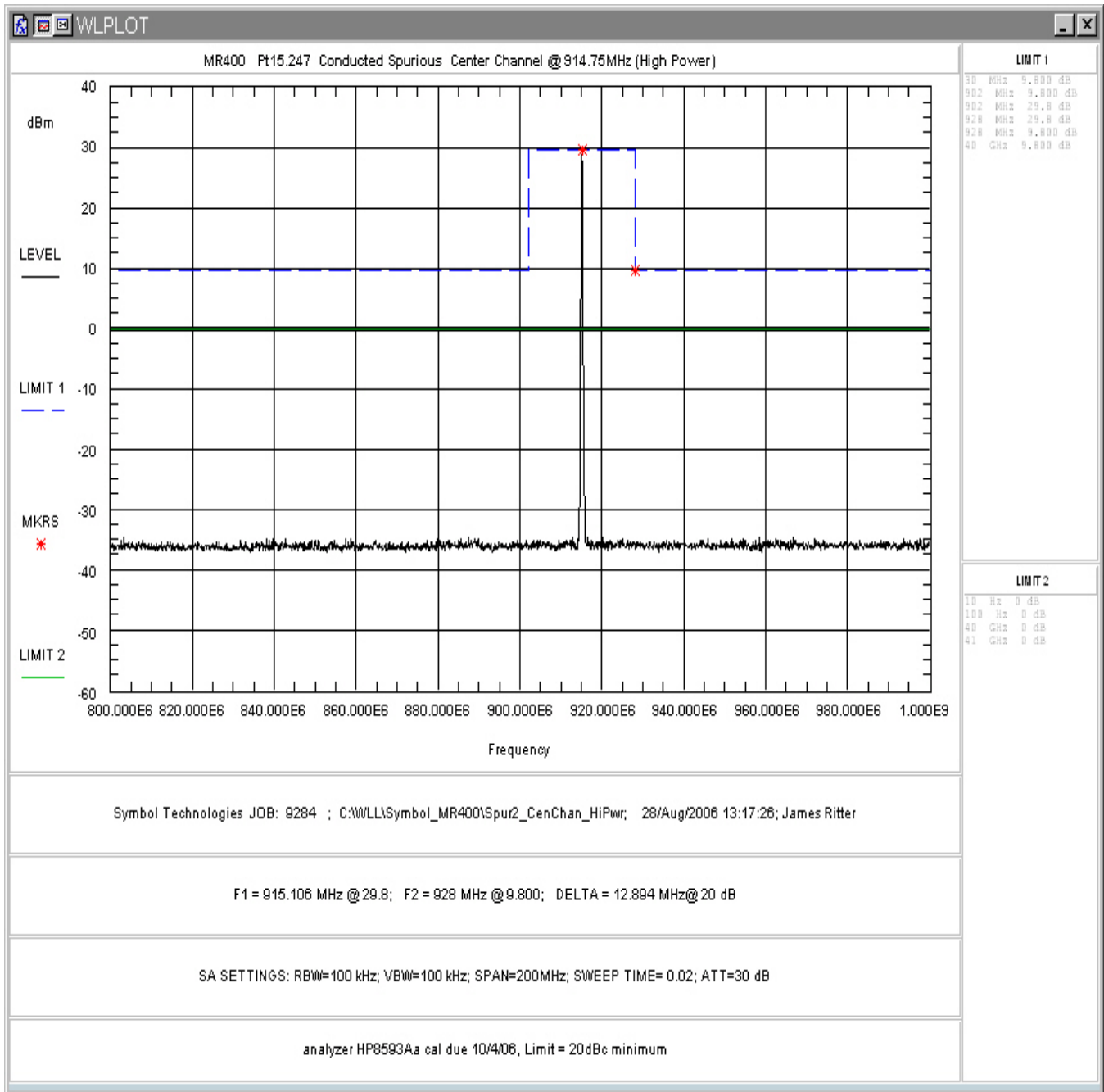

Figure 4-31. Conducted Spurious Emissions (High Power), Mid Channel 800 – 1000MHz

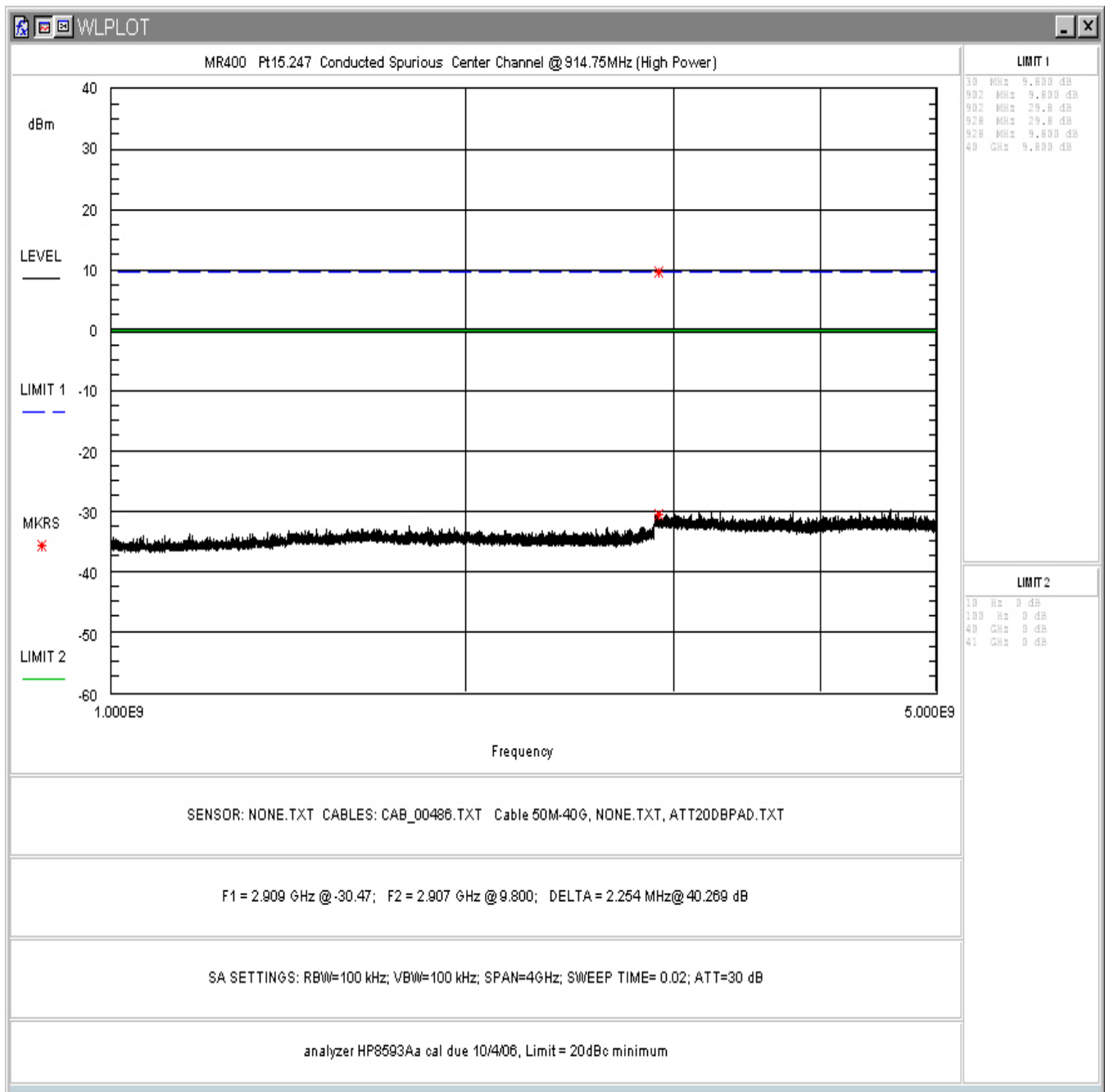

Figure 4-32. Conducted Spurious Emissions (High Power), Mid Channel 1 –5GHz



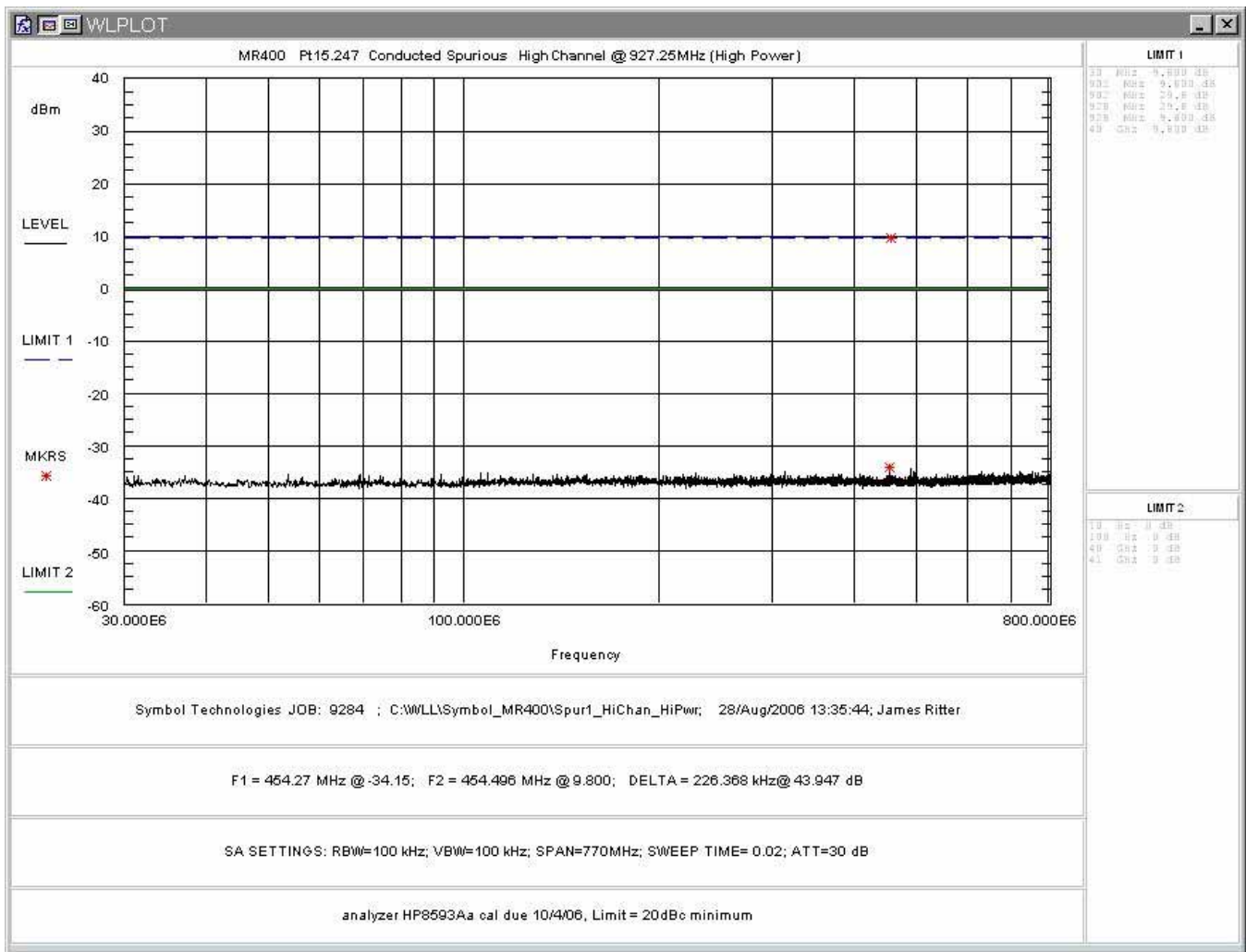

Figure 4-34. Conducted Spurious Emissions (High Power), High Channel 30 - 800MHz



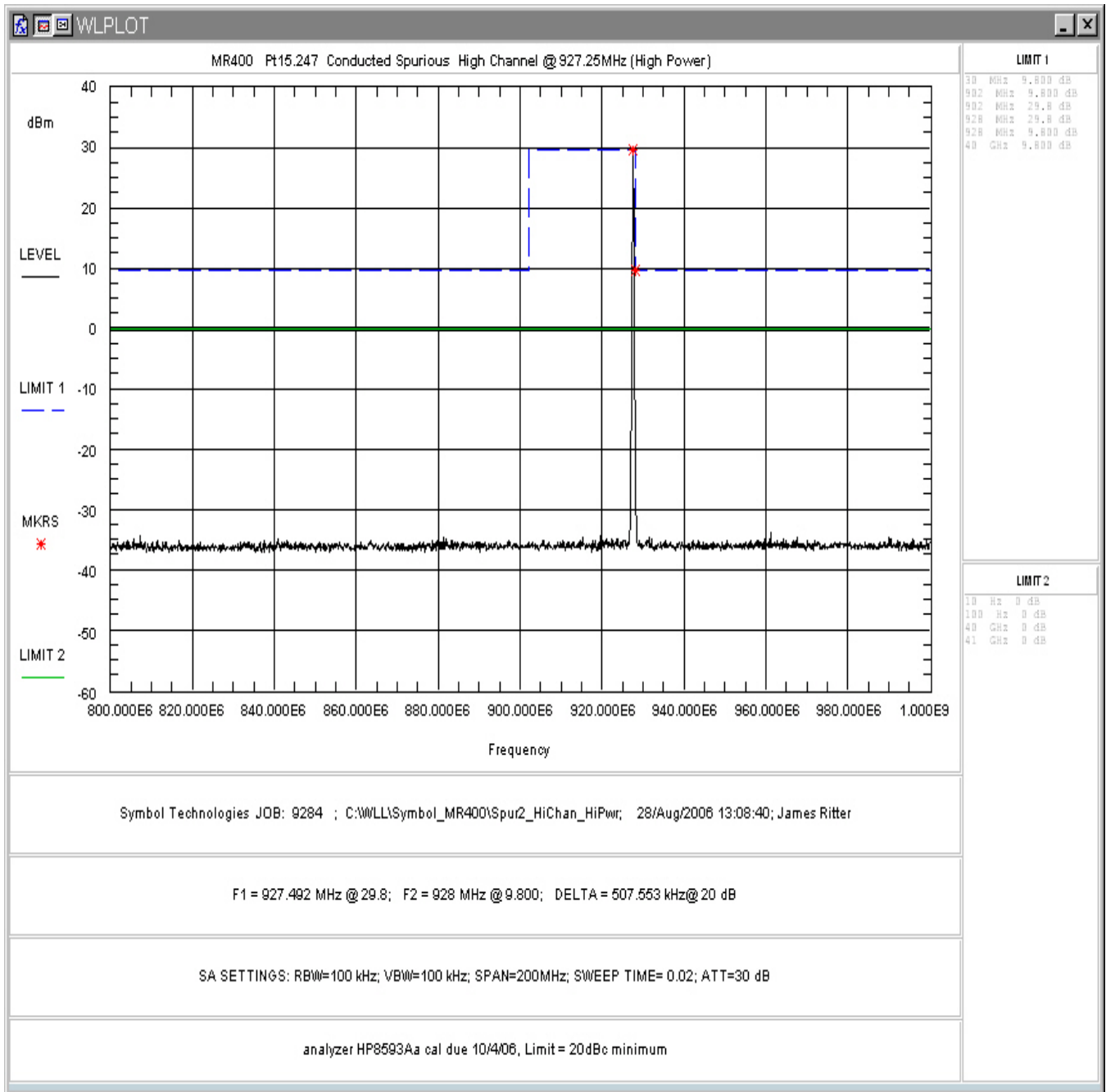

Figure 4-35. Conducted Spurious Emissions (High Power), High Channel 800 – 1000MHz

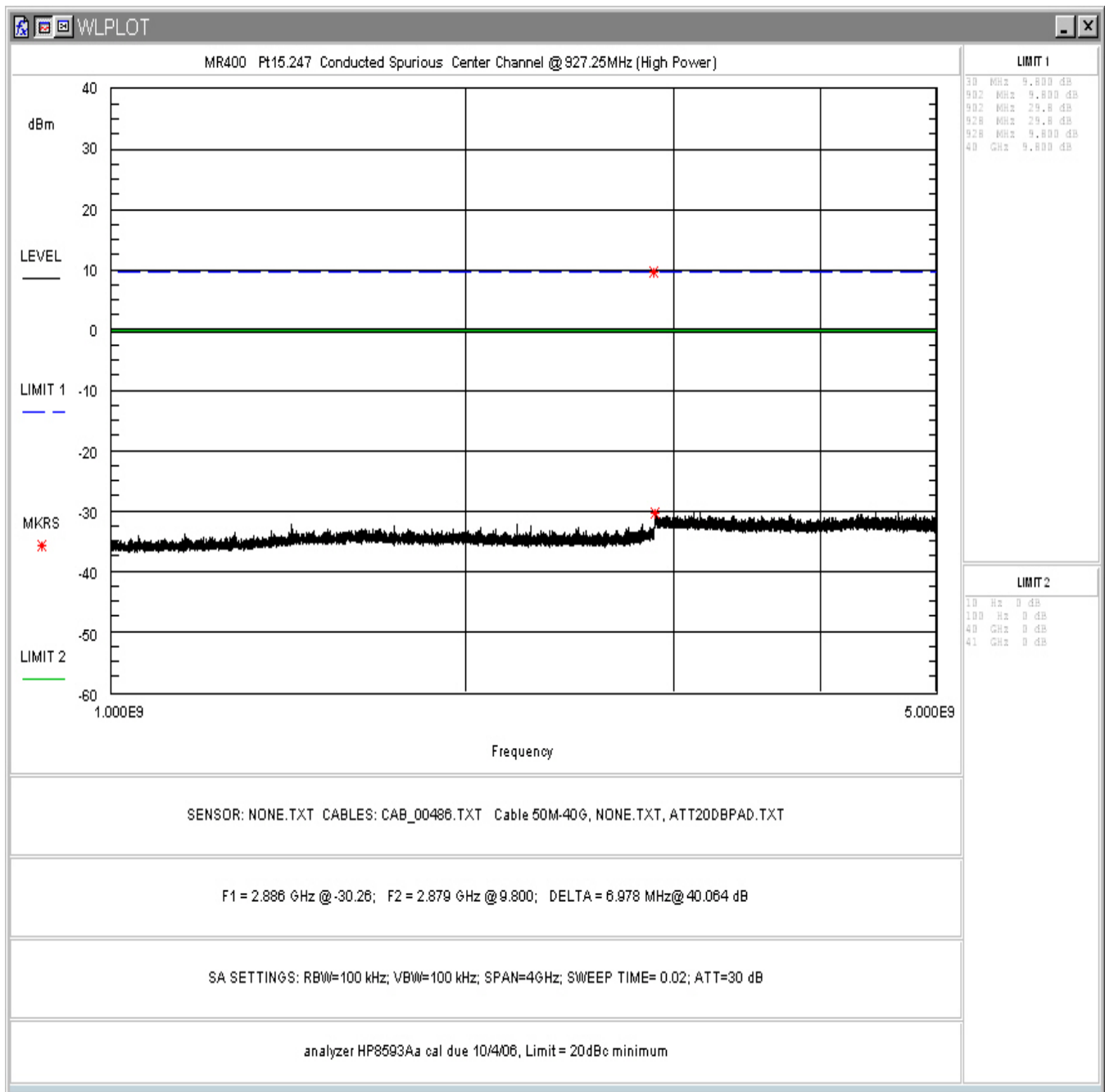

Figure 4-36. Conducted Spurious Emissions (High Power), High Channel 1 –5GHz

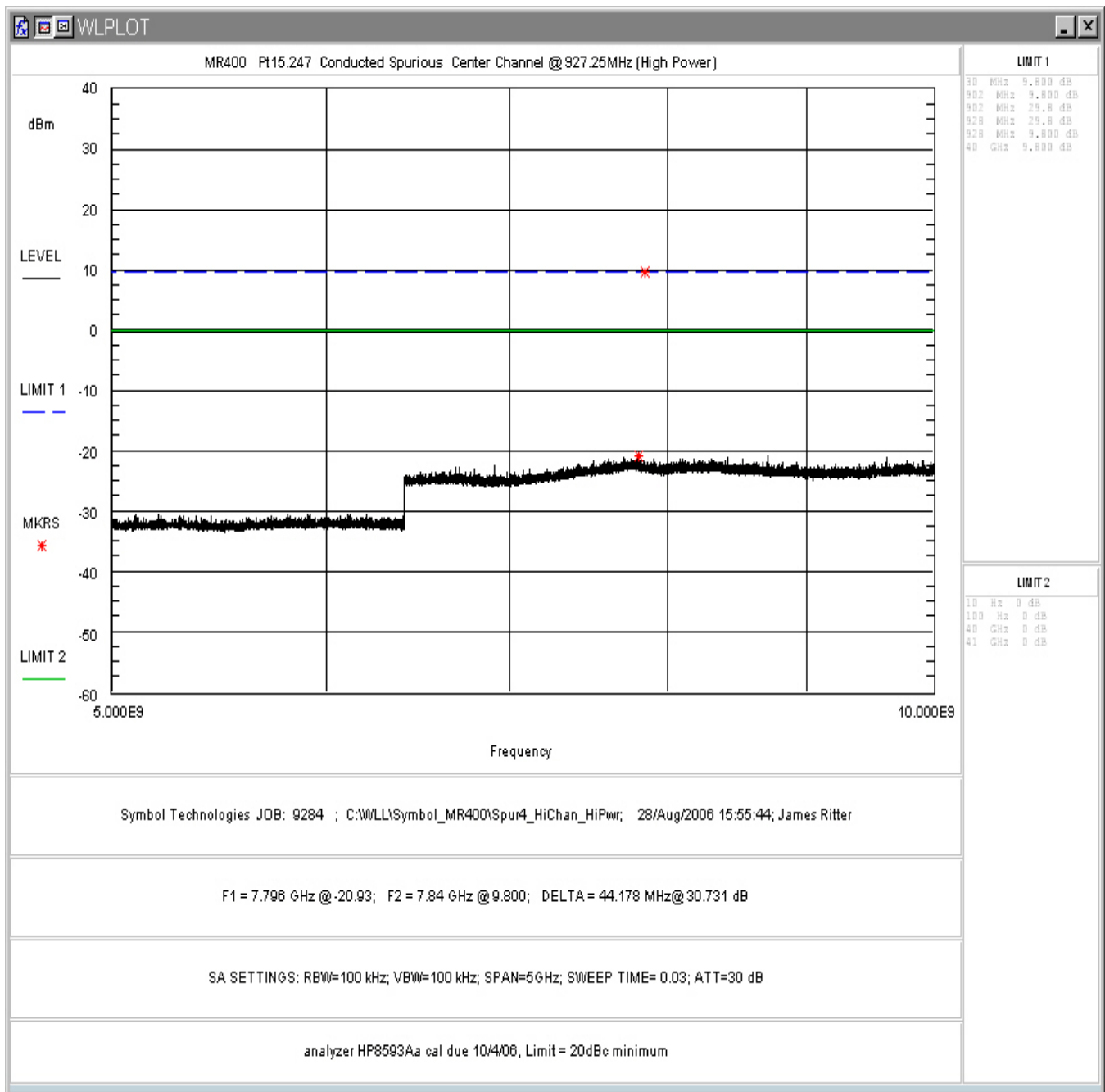

Figure 4-37. Conducted Spurious Emissions (High Power), High Channel 5 – 9.5GHz

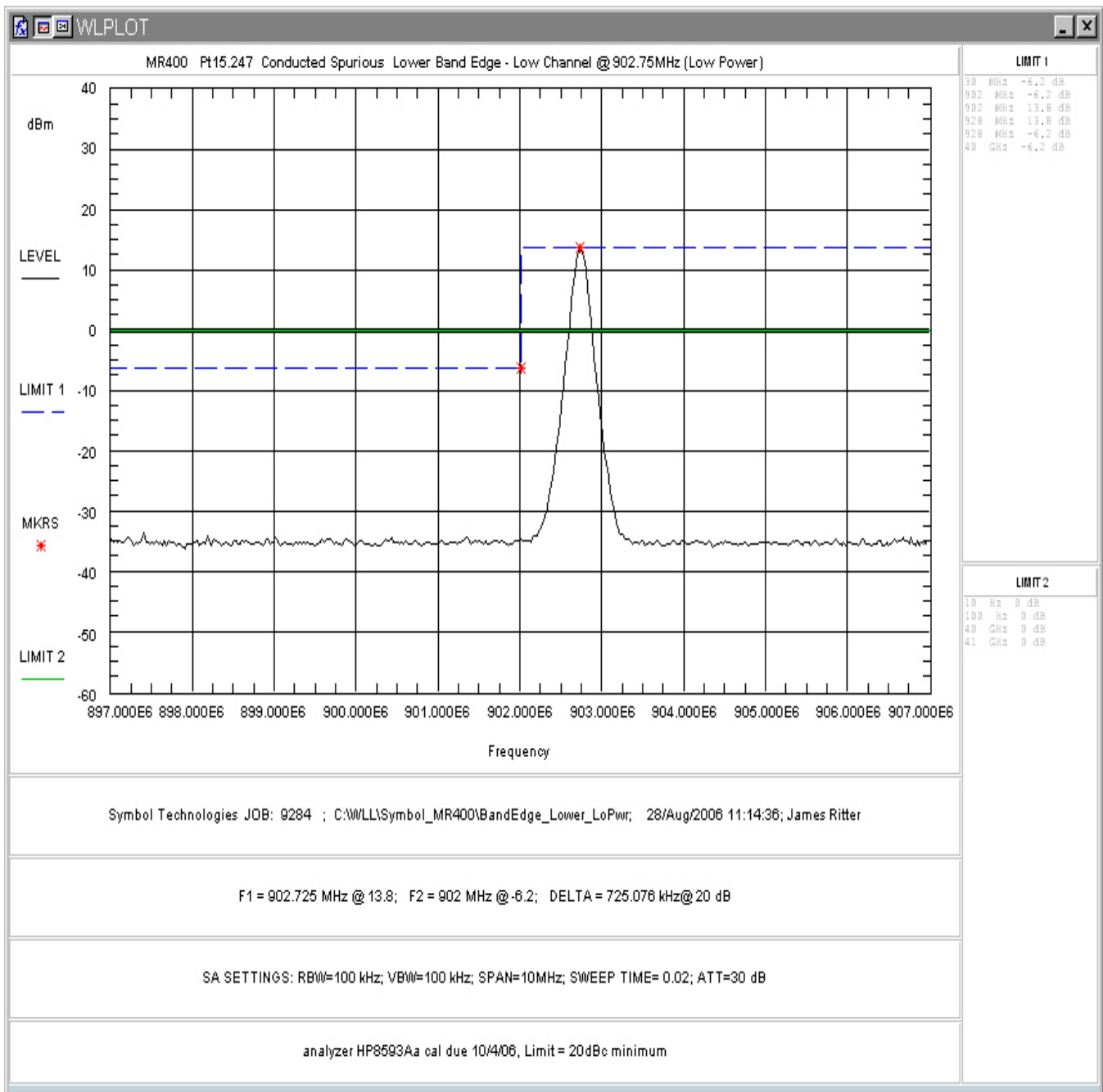

Figure 4-38. Conducted Bandedge, Low Channel, Low Power

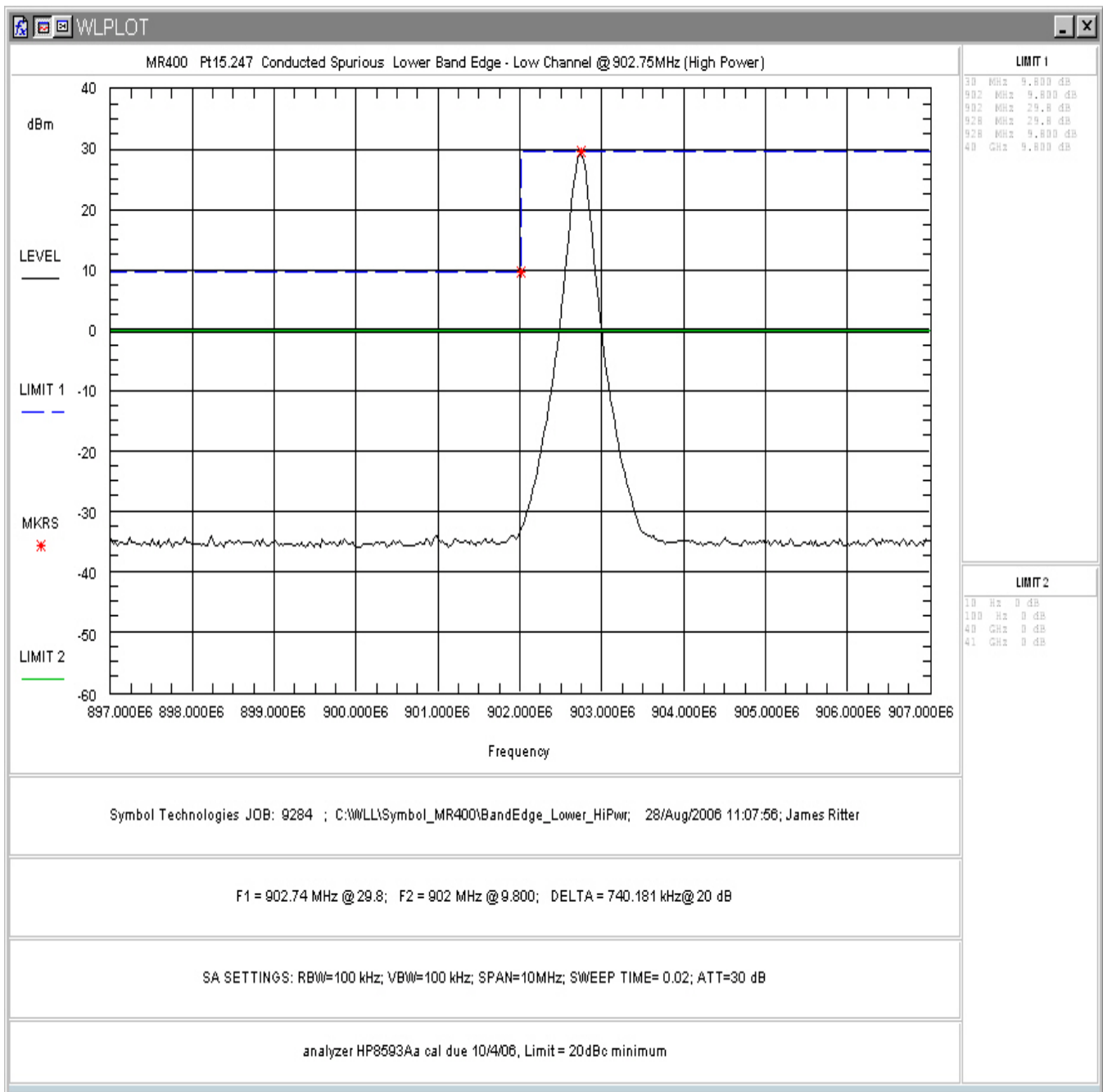

Figure 4-39. Conducted Bandedge, Low Channel, High Power

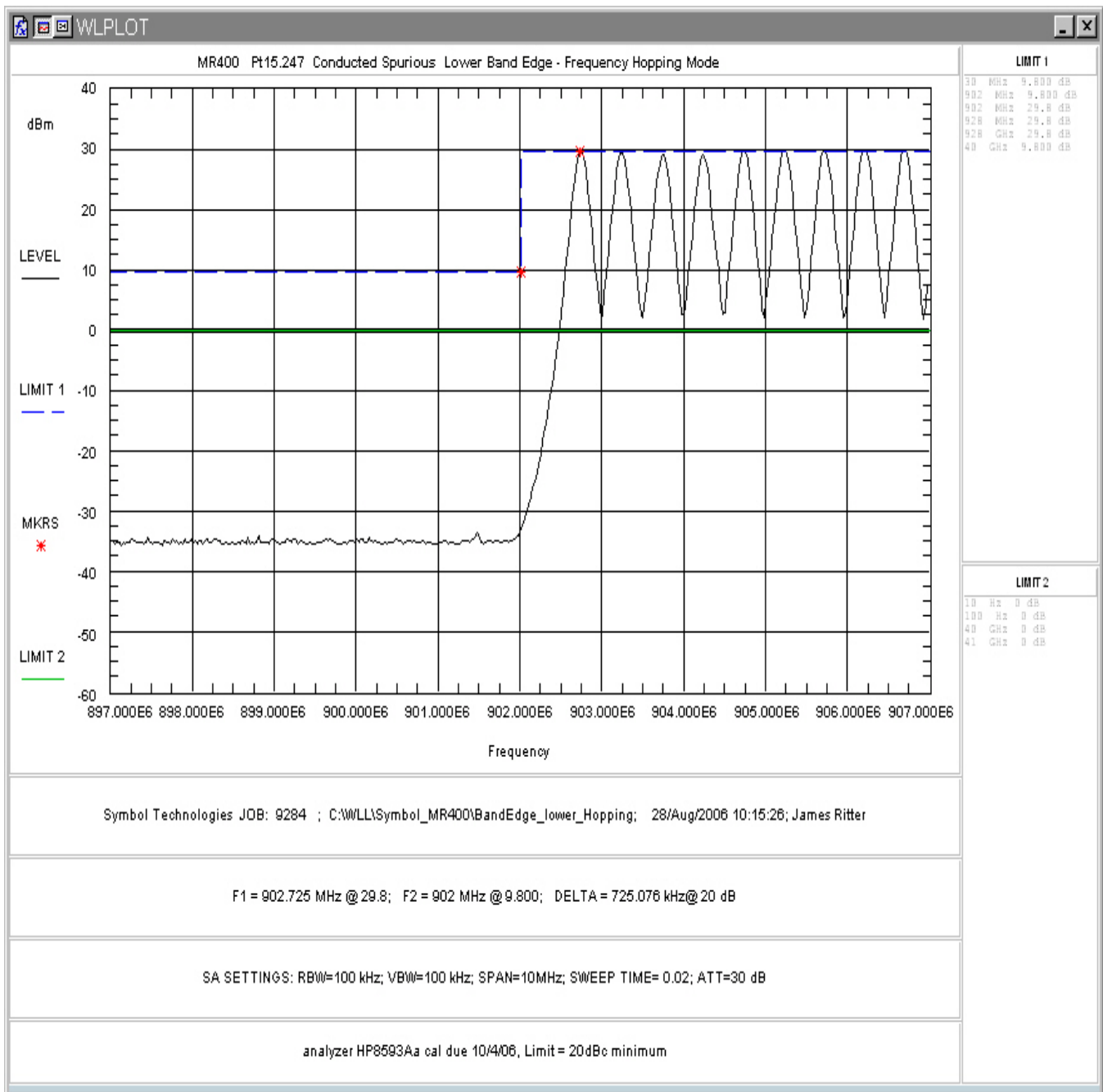

Figure 4-40. Conducted Bandedge, Low Channel, Hopping

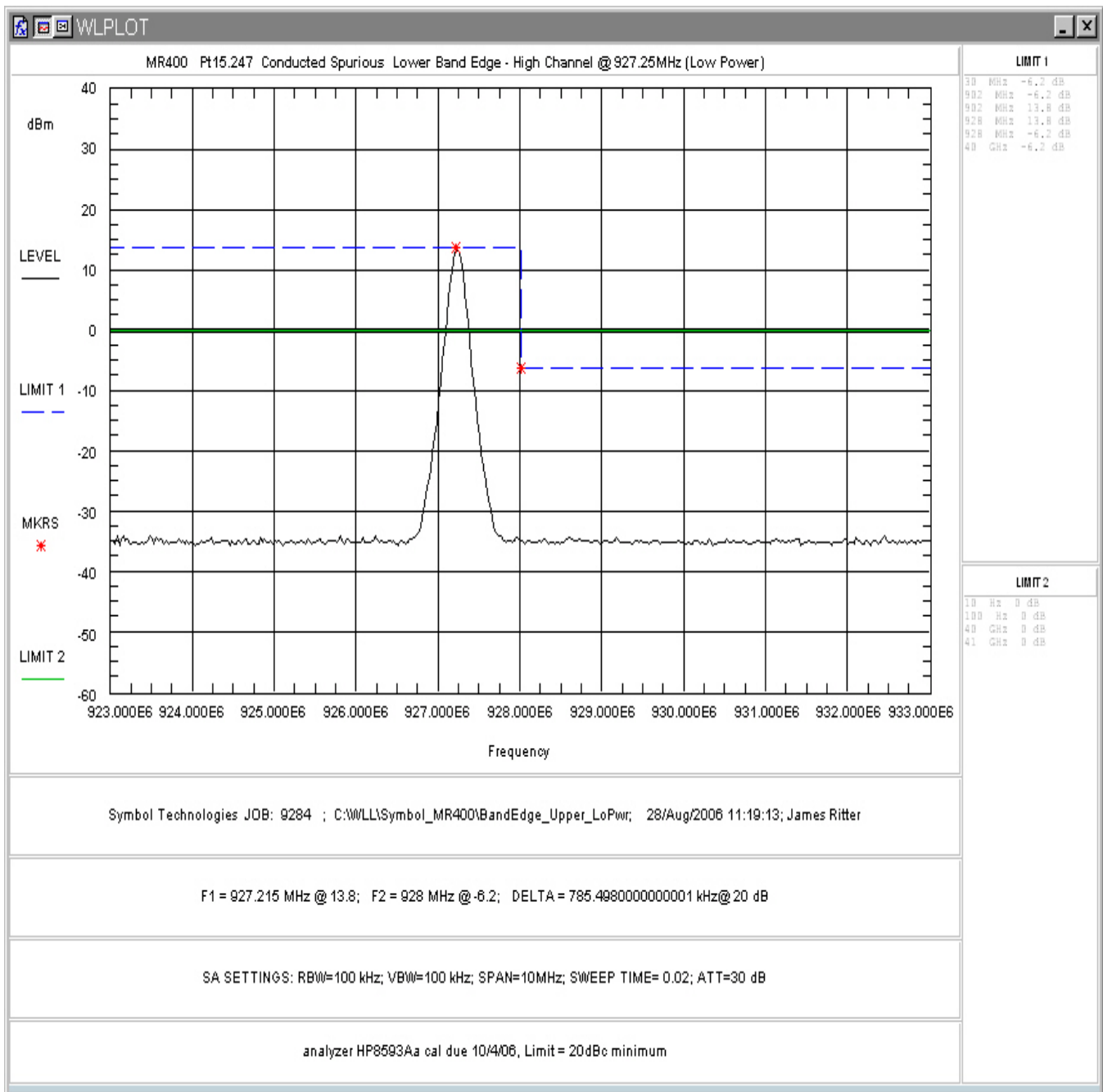

Figure 4-41. Conducted Bandedge, High Channel, Low Power

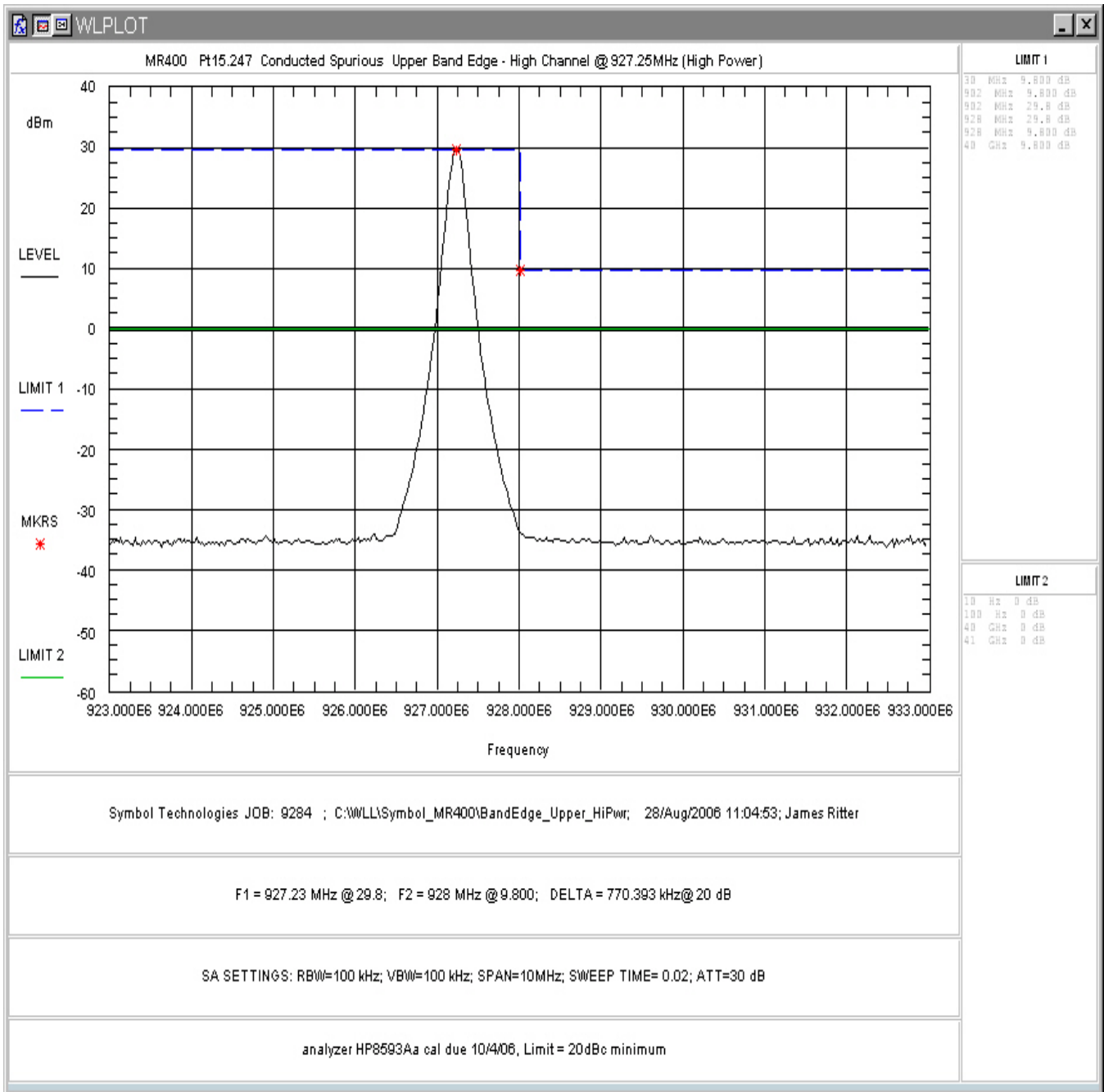
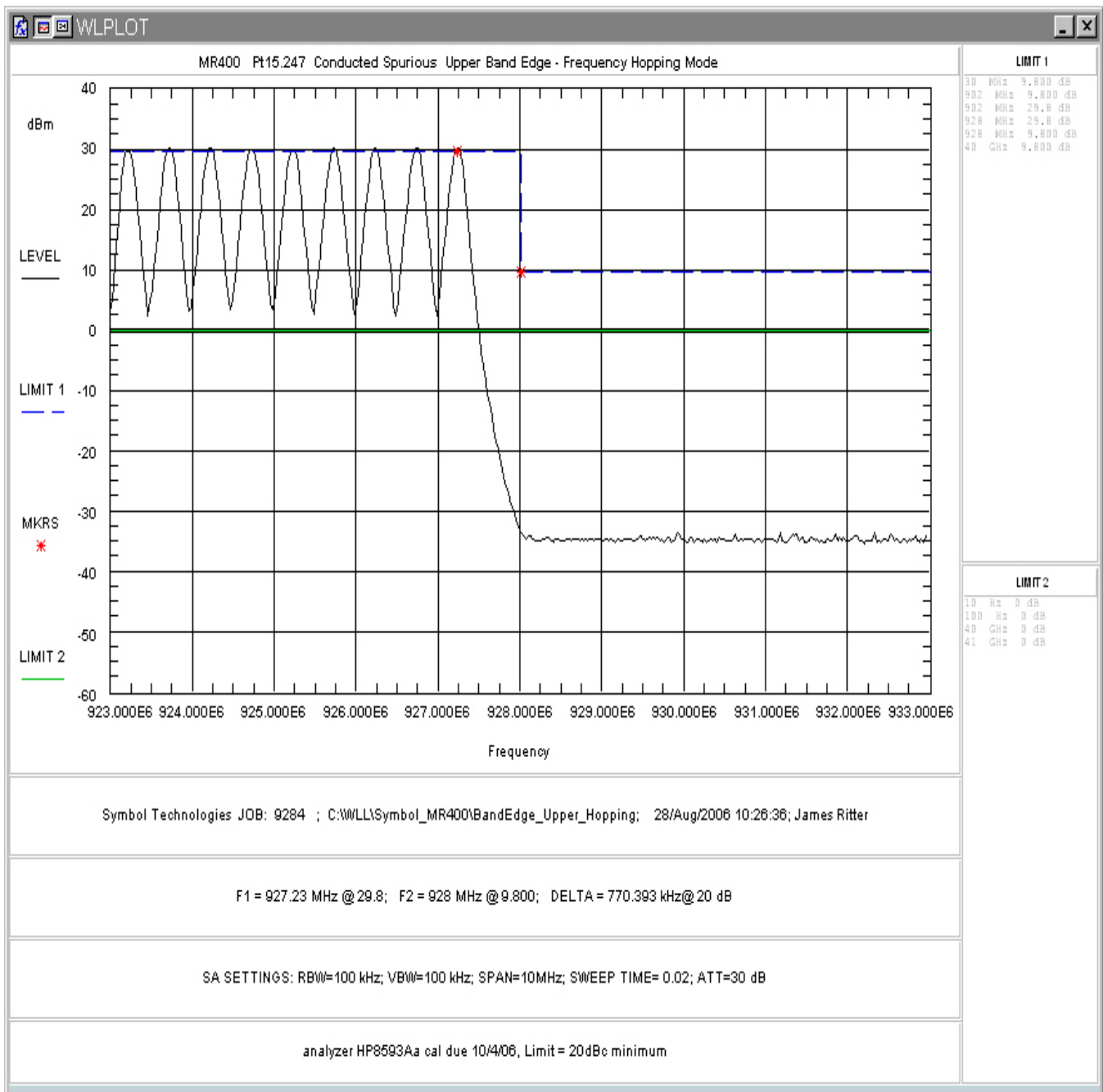

Figure 4-42. Conducted Bandedge, High Channel, High Power





**Figure 4-43. Conducted Bandedge, High Channel, Hopping**

#### 4.6 Radiated Spurious Emissions: (FCC Part §2.1053)

Radiated emissions that fall in the restricted bands must comply with the general emissions limits in 15.209(a) and RSS-210 Table 2.

The emissions were measured using the following resolution bandwidths:

Frequency Range	Resolution Bandwidth	Video Bandwidth
30MHz-1000 MHz	120kHz	>30 kHz
>1000 MHz	1 MHz	<30 Hz (Avg.) 1MHz (Peak)

Harmonic and Spurious emissions that were identified as coming from the EUT were checked in Peak and in Average Mode. It was verified that the peak-to-average ratio did not exceed 20dB.

Peak measurements and average measurements are made. All emissions were determined to have a peak-to-average ratio of less than 20 dB. Also, as described in FCC DA 00-705 if the dwell time per channel of the hopping signal is less than 100 ms then the average reading may be further adjusted by the duty cycle correction. No corrections were made to these data.

##### 4.6.1 Test Procedure

The EUT was placed on motorized turntable for radiated testing on a 3-meter open field test site. The emissions from the EUT were measured continuously at every azimuth by rotating the turntable. Receiving antennas were mounted on an antenna mast to determine the height of maximum emissions. The height of the antenna was varied between 1 and 4 meters. The peripherals were placed on the table in accordance with ANSI C63.4-2003. Cables were varied in position to produce maximum emissions. Both the horizontal and vertical field components were measured.

The emissions were measured using the following resolution bandwidths:

Frequency Range	Resolution Bandwidth	Video Bandwidth
30MHz-1000 MHz	120kHz	>100 kHz
>1000 MHz	1 MHz	<30 Hz (Avg.) 1MHz (Peak)

The following is a sample calculation used in the data tables for calculating the final field strength of spurious emissions and comparing these levels to the specified limits.

##### Sample Calculation:

Spectrum Analyzer Voltage (SA Level):      V dBμV  
 Antenna Factor (Ant Corr):                    AFdB/m  
 Cable Loss Correction (Cable Corr):        CCdB  
 Amplifier Gain:                                    GdB  
 Electric Field (Corr Level):                  EdBμV/m = VdBμV + AFdB/m + CCdB - GdB

To convert to linear units:  $E_{\mu V/m} = \text{antilog}(E_{dB\mu V/m}/20)$

Data are supplied in the following tables. Testing was performed to 10GHz. No emissions were detected above the 5<sup>th</sup> harmonic. Emissions below 1GHz are the same for all channels. All detected emissions are reported in the following tables. Both peak and average measurements are listed.

**Table 6: Radiated Emission Test Data, Low Frequency Data (<1GHz)**

Frequency (MHz)	Polarity H/V	Az Deg	Ant. Height (m)	SA Level (QP) (dBµV)	Ant. Corr. (dB/m)	Cable Corr. (dB)	Corr. Level (dBµV/m)	Corr. Level (µV/m)	Limit (µV/m)	Margin (dB)
33.300	V	90.0	1.0	5.1	22.2	1.3	28.7	27.1	100.0	-11.3
51.798	V	90.0	1.0	3.1	13.9	1.6	18.6	8.6	100.0	-21.4
52.000	V	100.0	1.5	1.9	13.8	1.6	17.4	7.4	100.0	-22.6
91.016	V	45.0	1.0	2.5	9.0	2.0	13.5	4.7	150.0	-30.0
173.360	V	270.0	1.0	2.9	10.9	2.6	16.4	6.6	150.0	-27.2
181.980	V	125.0	1.2	3.1	10.4	2.7	16.2	6.5	150.0	-27.3
295.560	V	90.0	2.8	9.5	13.5	3.3	26.4	20.8	200.0	-19.7
380.070	V	120.0	2.0	0.0	15.6	3.8	19.4	9.3	200.0	-26.6
390.914	V	120.0	2.5	3.8	16.0	3.8	23.7	15.2	200.0	-22.4
33.300	H	270.0	4.0	3.5	22.2	1.3	27.1	22.6	100.0	-12.9
51.798	H	90.0	4.0	5.1	13.9	1.6	20.6	10.8	100.0	-19.4
52.000	H	180.0	2.6	4.7	13.8	1.6	20.2	10.2	100.0	-19.8
123.948	H	0.0	3.5	7.0	12.3	2.3	21.6	12.0	150.0	-21.9
173.360	H	90.0	3.0	1.5	10.9	2.6	15.0	5.6	150.0	-28.6
181.980	H	180.0	2.0	5.9	10.4	2.7	19.0	8.9	150.0	-24.5
295.560	H	255.0	2.5	7.8	13.5	3.3	24.7	17.1	200.0	-21.4
390.914	H	90.0	3.6	3.6	16.0	3.8	23.5	14.9	200.0	-22.6
429.060	H	90.0	2.0	4.1	16.9	4.0	25.0	17.8	200.0	-21.0

**Table 7: Radiated Emission Test Data, High Frequency Data (>1GHz) (Restricted Bands)**

Frequency (MHz)	Polarity H/V	Az Deg	Ant. Height (m)	SA Level (dBµV)	Ant. Corr. (dB/m)	Cable Corr. (dB)	Amp Gain (dB)	Corr. Level (dBµV/m)	Corr. Level (µV/m)	Limit (µV/m)	Margin (dB)
<b>914.750</b>				Avg.							
2744.600	V	125.0	1.0	59.7	29.6	1.5	38.0	52.7	434.0	500.0	-1.2
3659.000	V	45.0	1.0	53.2	30.8	2.5	37.4	49.1	283.7	500.0	-4.9
4573.750	V	125.0	1.0	39.9	32.1	3.4	37.2	38.2	81.1	500.0	-15.8
				Peak							
2744.600	H	125.0	1.0	66.3	29.6	1.5	38.0	59.3	926.7	5000.0	-14.6
3659.000	H	45.0	1.0	59.1	30.8	2.5	37.4	54.9	558.3	5000.0	-19.0
4573.750	H	125.0	1.0	50.8	32.1	3.4	37.2	49.0	283.2	5000.0	-24.9
				Avg.							
2744.600	H	125.0	1.0	50.3	29.6	1.5	38.0	43.4	147.4	500.0	-10.6
3659.000	H	125.0	1.0	49.1	30.8	2.5	37.4	45.0	176.9	500.0	-9.0
4573.750	H	125.0	1.0	37.6	32.1	3.4	37.2	35.9	62.3	500.0	-18.1
				Peak							
2744.600	H	125.0	1.0	57.8	29.6	1.5	38.0	50.8	347.9	5000.0	-23.2
3659.000	H	125.0	1.0	55.6	30.8	2.5	37.4	51.4	373.5	5000.0	-22.5
4573.750	H	125.0	1.0	50.1	32.1	3.4	37.2	48.4	262.5	5000.0	-25.6
				Avg.							
<b>927.250</b>				Avg.							
2781.750	V	125.0	1.0	57.8	29.6	1.5	38.0	50.9	351.9	500.0	-3.1
4636.250	V	90.0	1.0	38.3	32.2	3.4	37.2	36.7	68.4	500.0	-17.3
3709.000	V	125.0	1.0	47.9	30.8	2.6	37.4	43.9	157.5	500.0	-10.0
				Peak							
2781.750	V	125.0	1.0	64.7	29.6	1.5	38.0	57.8	773.5	5000.0	-16.2
4636.250	V	90.0	1.0	49.1	32.2	3.4	37.2	47.5	236.4	5000.0	-26.5
3709.000	V	125.0	1.0	56.1	30.8	2.6	37.4	52.1	403.5	5000.0	-21.9
				Avg.							
2781.750	H	125.0	1.0	52.3	29.6	1.5	38.0	45.4	185.8	500.0	-8.6
4636.250	H	45.0	1.0	38.8	32.2	3.4	37.2	37.2	72.2	500.0	-16.8
3709.000	H	120.0	1.0	48.6	30.8	2.6	37.4	44.6	169.0	500.0	-9.4
				Peak							
2781.750	H	125.0	1.0	60.6	29.6	1.5	38.0	53.7	482.4	5000.0	-20.3
4636.250	H	45.0	1.0	49.8	32.2	3.4	37.2	48.2	257.4	5000.0	-25.8
3709.000	H	120.0	1.0	56.4	30.8	2.6	37.4	52.4	415.8	5000.0	-21.6
				Avg.							
<b>902.750</b>				Avg.							
2708.250	V	0.0	1.0	52.7	29.5	1.5	38.1	45.7	191.9	500.0	-8.3
3611.000	V	90.0	1.0	51.3	30.7	2.5	37.5	46.9	222.4	500.0	-7.0
4513.750	V	125.0	1.0	40.0	32.0	3.3	37.2	38.1	80.8	500.0	-15.8
				Peak							
2708.250	V	0.0	1.0	60.6	29.5	1.5	38.1	53.5	474.2	5000.0	-20.5
3611.000	V	90.0	1.0	57.8	30.7	2.5	37.5	53.5	474.3	5000.0	-20.5
4513.750	V	125.0	1.0	50.9	32.0	3.3	37.2	49.0	281.7	5000.0	-25.0

Frequency (MHz)	Polarity H/V	Az Deg	Ant. Height (m)	SA Level (dB $\mu$ V)	Ant. Corr. (dB/m)	Cable Corr. (dB)	Amp Gain (dB)	Corr. Level (dB $\mu$ V/m)	Corr. Level ( $\mu$ V/m)	Limit ( $\mu$ V/m)	Margin (dB)
				Avg.							
2708.250	H	250.0	1.0	48.1	29.5	1.5	38.1	41.1	113.5	500.0	-12.9
3611.000	H	125.0	1.0	52.1	30.7	2.5	37.5	47.8	244.4	500.0	-6.2
4513.750	H	125.0	1.0	39.9	32.0	3.3	37.2	38.1	80.2	500.0	-15.9
				Peak							
2708.250	H	250.0	1.0	57.1	29.5	1.5	38.1	50.1	318.8	5000.0	-23.9
3611.000	H	125.0	1.0	58.7	30.7	2.5	37.5	54.4	524.9	5000.0	-19.6
4513.750	H	125.0	1.0	50.4	32.0	3.3	37.2	48.6	268.7	5000.0	-25.4

#### 4.7 AC Powerline Conducted Emissions: (FCC Part §15.207 and RSS-GEN)

The EUT was placed on an 80 cm high 1 x 1.5 m non-conductive table above a ground plane. Power to the EUT was provided through a Solar Corporation 50 Ω/50 μH Line Impedance Stabilization Network bonded to a 3 x 2 meter ground plane. The LISN has its AC input supplied from a filtered AC power source. Power and data cables were moved about to obtain maximum emissions.

The 50Ω output of the LISN was connected to the input of the spectrum analyzer and the emissions in the frequency range of 150 kHz to 30 MHz were measured. The detector function was set to quasi-peak, peak, or average as appropriate, and the resolution bandwidth during testing was at least 9 kHz, with all post-detector filtering no less than 10 times the resolution bandwidth for peak measurements.

Data is recorded in the following table. Note: Power provided from Radio Shack 3-6.5V 2.5A Adjustable AC/DC Power adaptor (set to 5VDC)

**Table 8. Conducted Emissions Test Data; §15.207**

**LINE 1 - NEUTRAL**

Frequency (MHz)	Level QP (dBμV)	Cable Loss (dB)	LISN Corr (dB)	Limit QP (dBμV)	Level Corr (dBμV)	Margin QP (dB)	Level AVG (dBμV)	Cable Loss (dB)	Level Corr (dBμV)	Limit AVG (dBμV)	Margin AVG (dB)
0.174	47.2	10.2	0.3	64.8	57.8	-7.0	29.8	10.2	40.4	54.8	-14.4
0.278	41.9	10.1	0.2	60.9	52.2	-8.6	26.3	10.1	36.6	50.9	-14.2
0.560	33.6	10.2	0.2	56.0	44.0	-12.0	17.4	10.2	27.8	46.0	-18.2
0.734	33.6	10.2	0.2	56.0	44.0	-12.0	11.9	10.2	22.3	46.0	-23.7
1.449	32.5	10.4	0.3	56.0	43.2	-12.8	12.5	10.4	23.2	46.0	-22.8
5.715	31.2	10.9	1.2	60.0	43.3	-16.7	10.9	10.9	23.0	50.0	-27.0
16.488	25.6	11.6	3.4	60.0	40.6	-19.4	10.8	11.6	25.8	50.0	-24.2

**LINE 2 - PHASE**

Frequency (MHz)	Level QP (dBμV)	Cable Loss (dB)	LISN Corr (dB)	Limit QP (dBμV)	Level Corr (dBμV)	Margin QP (dB)	Level AVG (dBμV)	Cable Loss (dB)	Level Corr (dBμV)	Limit AVG (dBμV)	Margin AVG (dB)
0.174	49.9	10.2	0.7	64.8	60.8	-4.0	28.3	10.2	39.2	54.8	-15.6
0.272	42.9	10.1	0.4	61.1	53.4	-7.6	18.3	10.1	28.8	51.1	-22.2
0.560	37.0	10.2	0.3	56.0	47.5	-8.5	22.0	10.2	32.5	46.0	-13.5
0.734	38.0	10.2	0.3	56.0	48.5	-7.5	15.9	10.2	26.4	46.0	-19.6
1.437	35.9	10.4	0.3	56.0	46.6	-9.4	15.3	10.4	26.0	46.0	-20.0
5.715	34.1	10.9	0.9	60.0	45.9	-14.1	15.9	10.9	27.7	50.0	-22.3
13.870	28.9	11.5	2.0	60.0	42.4	-17.6	14.9	11.5	28.4	50.0	-21.6