



A D T

# FCC TEST REPORT (15.407)

**REPORT NO.:** RF981022L04-1

**MODEL NO.:** MC75A8

**RECEIVED:** Oct. 22, 2009

**TESTED:** Apr. 17 ~ Apr. 20, 2010

**ISSUED:** Jun. 17, 2010

**APPLICANT:** Symbol Technologies, Inc.

**ADDRESS:** One Motorola Plaza, Holtsville, NY-11742-1300,  
U.S.A.

**ISSUED BY:** Bureau Veritas Consumer Products Services (H.K.)  
Ltd., Taoyuan Branch

**LAB ADDRESS:** No. 47, 14th Ling, Chia Pau Tsuen, Lin Kou Hsiang,  
Taipei Hsien 244, Taiwan, R.O.C.

**TEST LOCATION:** No. 19, Hwa Ya 2nd Rd, Wen Hwa Tsuen, Kwei  
Shan Hsiang, Taoyuan Hsien 333, Taiwan, R.O.C.

This test report consists of 60 pages in total. It may be duplicated completely for legal use with the approval of the applicant. It should not be reproduced except in full, without the written approval of our laboratory. The client should not use it to claim product endorsement by TAF or any government agencies. The test results in the report only apply to the tested sample.





A D T

## TABLE OF CONTENTS

1.	CERTIFICATION.....	4
2.	SUMMARY OF TEST RESULTS .....	5
2.1	MEASUREMENT UNCERTAINTY.....	5
3.	GENERAL INFORMATION.....	6
3.1	GENERAL DESCRIPTION OF EUT .....	6
3.2	DESCRIPTION OF TEST MODES.....	8
3.2.1	CONFIGURATION OF SYSTEM UNDER TEST .....	8
3.2.2	TEST MODE APPLICABILITY AND TESTED CHANNEL DETAIL .....	9
3.3	GENERAL DESCRIPTION OF APPLIED STANDARDS .....	11
3.4	DESCRIPTION OF SUPPORT UNITS .....	11
4.	TEST TYPES AND RESULTS .....	12
4.1	RADIATED EMISSION MEASUREMENT .....	12
4.1.1	LIMITS OF RADIATED EMISSION MEASUREMENT.....	12
4.1.2	LIMITS OF UNWANTED EMISSION OUT OF THE RESTRICTED BANDS.....	12
4.1.3	TEST INSTRUMENTS.....	13
4.1.4	TEST PROCEDURES .....	14
4.1.5	DEVIATION FROM TEST STANDARD.....	14
4.1.6	TEST SETUP.....	15
4.1.7	EUT OPERATING CONDITION.....	15
4.1.8	TEST RESULTS .....	16
4.2	CONDUCTED EMISSION MEASUREMENT .....	28
4.2.1	LIMITS OF CONDUCTED EMISSION MEASUREMENT.....	28
4.2.2	TEST INSTRUMENTS.....	28
4.2.3	TEST PROCEDURES .....	29
4.2.4	DEVIATION FROM TEST STANDARD.....	29
4.2.5	TEST SETUP.....	30
4.2.6	EUT OPERATING CONDITIONS .....	30
4.2.7	TEST RESULTS .....	31
4.3	MAXIMUM CONDUCTED OUTPUT POWER MEASUREMENT .....	35
4.3.1	LIMITS OF MAXIMUM CONDUCTED OUTPUT POWER MEASUREMENT.....	35
4.3.2	TEST INSTRUMENTS.....	35
4.3.3	TEST PROCEDURES .....	36
4.3.4	DEVIATION FROM TEST STANDARD.....	36
4.3.5	TEST SETUP.....	36
4.3.6	EUT OPERATING CONDITIONS .....	36
4.3.7	TEST RESULTS .....	37



A D T

4.4	PEAK POWER EXCURSION MEASUREMENT .....	39
4.4.1	LIMITS OF PEAK POWER EXCURSION MEASUREMENT .....	39
4.4.2	TEST INSTRUMENTS.....	39
4.4.3	TEST PROCEDURE.....	39
4.4.4	DEVIATION FROM TEST STANDARD.....	40
4.4.5	TEST SETUP .....	40
4.4.6	EUT OPERATING CONDITIONS .....	40
4.4.7	TEST RESULTS .....	41
4.5	PEAK POWER SPECTRAL DENSITY MEASUREMENT .....	43
4.5.1	LIMITS OF PEAK POWER SPECTRAL DENSITY MEASUREMENT .....	43
4.5.2	TEST INSTRUMENTS.....	43
4.5.3	TEST PROCEDURES .....	43
4.5.4	DEVIATION FROM TEST STANDARD.....	44
4.5.5	TEST SETUP .....	44
4.5.6	EUT OPERATING CONDITIONS .....	44
4.5.7	TEST RESULTS .....	45
4.6	FREQUENCY STABILITY.....	46
4.6.1	LIMITS OF FREQUENCY STABILITY MEASUREMENT .....	46
4.6.2	TEST INSTRUMENTS.....	46
4.6.3	TEST PROCEDURE.....	46
4.6.4	DEVIATION FROM TEST STANDARD.....	47
4.6.5	TEST SETUP .....	47
4.6.6	EUT OPERATING CONDITION.....	47
4.6.7	TEST RESULTS .....	48
4.7	BAND EDGES MEASUREMENT .....	49
4.7.1	TEST INSTRUMENTS.....	49
4.7.2	TEST PROCEDURE.....	49
4.7.3	EUT OPERATING CONDITION.....	49
4.7.4	TEST RESULTS .....	49
5.	PHOTOGRAPHS OF THE TEST CONFIGURATION.....	58
6.	INFORMATION ON THE TESTING LABORATORIES .....	59
7.	APPENDIX A - MODIFICATIONS RECORDERS FOR ENGINEERING CHANGES TO THE EUT BY THE LAB .....	60



# 1. CERTIFICATION

**PRODUCT:** EDA (Enterprise Digital Assistant)  
**MODEL NO.:** MC75A8  
**BRAND:** Symbol  
**APPLICANT:** Symbol Technologies, Inc.  
**TESTED:** Apr. 17 ~ Apr. 20, 2010  
**TEST SAMPLE:** PROTOTYPE  
**STANDARDS:** **FCC Part 15, Subpart E (Section 15.407)**  
ANSI C63.4-2003

The above equipment (Model: MC75A8) has been tested by **Bureau Veritas Consumer Products Services (H.K.) Ltd., Taoyuan Branch**, and found compliance with the requirement of the above standards. The test record, data evaluation & Equipment Under Test (EUT) configurations represented herein are true and accurate accounts of the measurements of the sample's EMC characteristics under the conditions specified in this report.

**PREPARED BY :** *Joanna Wang* , **DATE :** Jun. 17, 2010  
Joanna Wang / Senior Specialist

**TECHNICAL ACCEPTANCE :** *Long Chen* , **DATE :** Jun. 17, 2010  
Responsible for RF Long Chen / Senior Engineer

**APPROVED BY :** *Gary Chang* , **DATE :** Jun. 17, 2010  
Gary Chang / Assistant Manager

REVISED VERSION	REVISED DATE	DESCRIPTION
Ver. 1	Apr. 26, 2010	1. Reduce output power of WLAN. 2. TX diversity function is disabled by software. Only main antenna can transmit.
Ver. 2	Jun. 14, 2010	Modified the general information
Ver. 3	Jun. 17, 2010	Modified typing error.

## 2. SUMMARY OF TEST RESULTS

The EUT has been tested according to the following specifications:

APPLIED STANDARD: FCC PART 15, SUBPART E (SECTION 15.407)			
STANDARD SECTION	TEST TYPE AND LIMIT	RESULT	REMARK
15.407(b)(5)	AC Power Conducted Emission	PASS	Meet the requirement of limit. Minimum passing margin is -16.64dB at 0.154MHz.
15.407(b/1/2/3) (b)(5)	Electric Field Strength Spurious Emissions, 30MHz ~ 40000MHz	PASS	Meet the requirement of limit. Minimum passing margin is -6.7dB at 201.00MHz.
15.407(a/1/2/3)	Peak Transmit Power	PASS	Meet the requirement of limit.
15.407(a)(6)	Peak Power Excursion	PASS	Meet the requirement of limit.
15.407(a/1/2/3)	Peak Power Spectral Density	PASS	Meet the requirement of limit.
15.407(g)	Frequency Stability	PASS	Meet the requirement of limit.
15.203	Antenna Requirement	PASS	Antenna connector is IPEX not a standard connector.

### 2.1 MEASUREMENT UNCERTAINTY

Where relevant, the following measurement uncertainty levels have been estimated for tests performed on the EUT as specified in CISPR 16-4-2:

MEASUREMENT	FREQUENCY	UNCERTAINTY
Conducted emissions	150kHz ~ 30MHz	2.44dB
Radiated emissions	30MHz ~ 200MHz	2.93dB
	200MHz ~ 1000MHz	2.95dB
	1GHz ~ 18GHz	2.26dB
	18GHz ~ 40GHz	1.94dB

This uncertainty represents an expanded uncertainty expressed at approximately the 95% confidence level using a coverage factor of  $k = 2$ .



A D T

### 3. GENERAL INFORMATION

#### 3.1 GENERAL DESCRIPTION OF EUT

<b>EUT</b>	EDA (Enterprise Digital Assistant)
<b>MODEL NO.</b>	MC75A8
<b>FCC ID</b>	H9PMC75A8
<b>POWER SUPPLY</b>	3.7Vdc (Li-Lon battery) 5.4Vdc (Adapter)
<b>MODULATION TYPE</b>	64QAM, 16QAM, QPSK, BPSK
<b>MODULATION TECHNOLOGY</b>	OFDM
<b>TRANSFER RATE</b>	54.0/ 48.0/ 36.0/ 24.0/ 18.0/ 12.0/ 9.0/ 6.0Mbps
<b>OPERATING FREQUENCY</b>	5180 ~ 5320MHz & 5500 ~ 5700MHz
<b>NUMBER OF CHANNEL</b>	5180 ~ 5320MHz: 8 5500 ~ 5700MHz: 11
<b>OUTPUT POWER (AV POWER)</b>	8.0dBm (6.3mW) for 5180 ~ 5320MHz 9.9dBm (9.8mW) for 5500 ~ 5700MHz
<b>ANTENNA TYPE</b>	Refer to NOTE 4 as below
<b>ANTENNA CONNECTOR</b>	Refer to NOTE 4 as below
<b>DATA CABLE</b>	NA
<b>I/O PORTS</b>	Refer to user's manual
<b>ACCESSORY DEVICES</b>	Battery

**NOTE:**

1. The EUT is an EDA (Enterprise Digital Assistant). The test data are separated into following test reports:

	TEST STANDARD	REFERENCE REPORT
<b>WLAN 802.11b/g</b>	FCC Part 15, Subpart C (Section 15.247)	RF981022L04
<b>WLAN 802.11a (5745~5825 MHz)</b>		
<b>WLAN 802.11a (5180~5320MHz, 5500~5700MHz)</b>	FCC Part 15, Subpart E (Section 15.407)	RF981022L04-1
<b>WLAN 802.11a (For DFS report) (5260~5320MHz, 5500~5700MHz)</b>	FCC Part 15, Subpart E (Section 15.407)	RF981022L04-3
<b>BLUETOOTH</b>	FCC Part 15, Subpart C (Section 15.247)	RF981022L04-2
<b>CDMA 850</b>	FCC Part 22	RF981022L04-4
<b>CDMA 1900</b>	FCC Part 24	RF981022L04-5



2. The models identified as below are identical to each other except of the following options:

- Keypad: Numeric / QWERTY
- Barcode reader: 1D laser scanner / BB Imager

BRAND	MODEL	DESCRIPTION
Symbol	MC75A8	EVDO 1D Numeric
Symbol	MC75A8	EVDO 1D QWERTY
Symbol	MC75A8	EVDO BB Numeric
<b>Symbol</b>	<b>MC75A8</b>	<b>EVDO BB QWERTY</b>

\*\*the worst case had been marked by boldface.

3. The EUT uses the following Li-Lon batteries:

BATTERY 1 (1.5X)	
<b>BRAND:</b>	MOTOROLA
<b>PART NUMBER:</b>	82-71364-05 Rev D
<b>RATING:</b>	3.7Vdc, 3600mAh, 13.3Wh

BATTERY 2 (2.5X)	
<b>BRAND:</b>	MOTOROLA
<b>PART NUMBER:</b>	82-71364-06 Rev C
<b>RATING:</b>	3.7Vdc, 4800mAh, 17.7Wh

\*Battery 2 was chosen as the representative for testing.

4. The EUT used two antennas listed as below:

ANTENNA ITEM	ANTENNA TYPE	TX/RX FUNCTION	ANTENNA CONNECTER	ANTENNA GAIN (dBi)	
				2.4GHz	5.0GHz
MAIN ANTENNA	inverted F	TX/RX	IPEX	-4.39	2.05
AUX. ANTENNA	Planar inverted	RX only	IPEX	2.31	3.29

5. The following accessories are optional to the DUT.

PRODUCT	BRAND	MODEL	DESCRIPTION
RS232 charging cable	Motorola	25-102776-01R	1.2m non-shielded cable with one core
USB charging cable	Motorola	25-102775-01R	1.5m shielded cable with one core
Headset	Motorola	50-11300-050R	VR10 headset 0.8m non-shielded cable with one core
Power Supply Adaptor	Motorola	EADP-16BB A	I/P: 100-240Vac, 50-60Hz, 0.4A O/P: 5.4Vdc, 3A 1.8m non-shielded cable without core

6. The above EUT information was declared by manufacturer and for more detailed features description, please refer to the manufacturer's specifications or user's manual.

### 3.2 DESCRIPTION OF TEST MODES

#### Operated in 5180 ~ 5320MHz

8 channels are provided for 802.11a

CHANNEL	FREQUENCY	CHANNEL	FREQUENCY
36	5180 MHz	52	5260 MHz
40	5200 MHz	56	5280 MHz
44	5220 MHz	60	5300 MHz
48	5240 MHz	64	5320 MHz

#### Operated in 5500 ~ 5700MHz

11 channels are provided for 802.11a

CHANNEL	FREQUENCY	CHANNEL	FREQUENCY
100	5500 MHz	124	5620 MHz
104	5520 MHz	128	5640 MHz
108	5540 MHz	132	5660 MHz
112	5560 MHz	136	5680 MHz
116	5580 MHz	140	5700 MHz
120	5600 MHz		

#### 3.2.1 CONFIGURATION OF SYSTEM UNDER TEST

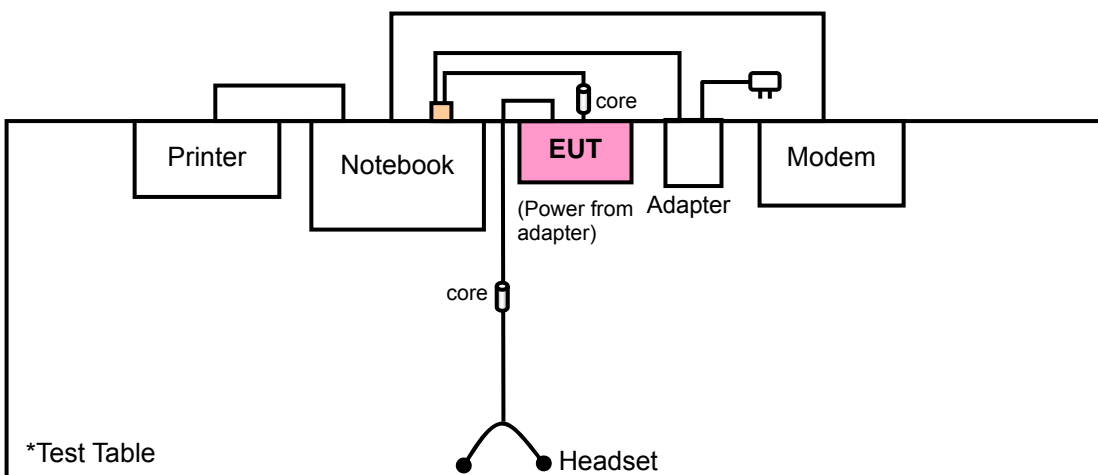





### 3.2.2 TEST MODE APPLICABILITY AND TESTED CHANNEL DETAIL

EUT CONFIGURE MODE	APPLICABLE TO				DESCRIPTION
	RE≥1G	RE<1G	PLC	APCM	
-	√	√	√	√	-

Where **RE≥1G**: Radiated Emission above 1GHz      **RE<1G**: Radiated Emission below 1GHz  
**PLC**: Power Line Conducted Emission      **APCM**: Antenna Port Conducted Measurement

#### RADIATED EMISSION TEST (ABOVE 1GHz):

- Pre-Scan has been conducted to determine the worst-case mode from all possible combinations between available modulations, data rates, XYZ axis and antenna ports (if EUT with antenna diversity architecture).
- Following channel(s) was (were) selected for the final test as listed below.

MODE	FREQ. BAND (MHz)	AVAILABLE CHANNEL	TESTED CHANNEL	MODULATION TECHNOLOGY	MODULATION TYPE	DATA RATE (Mbps)	AXIS
802.11a	5180-5320	36 to 64	36, 40, 48, 52, 60, 64	OFDM	BPSK	6.0	Y
802.11a	5500-5700	100 to 140	100, 116, 132, 140	OFDM	BPSK	6.0	Y

#### RADIATED EMISSION TEST (BELOW 1GHz):

- Pre-Scan has been conducted to determine the worst-case mode from all possible combinations between available modulations, data rates, XYZ axis and antenna ports (if EUT with antenna diversity architecture).
- Following channel(s) was (were) selected for the final test as listed below.

MODE	FREQ. BAND (MHz)	AVAILABLE CHANNEL	TESTED CHANNEL	MODULATION TECHNOLOGY	MODULATION TYPE	DATA RATE (Mbps)	AXIS
802.11a	5180-5320	36 to 64	64	OFDM	BPSK	6.0	Y
802.11a	5500-5700	100 to 140	132	OFDM	BPSK	6.0	Y

#### POWER LINE CONDUCTED EMISSION TEST:

- Pre-Scan has been conducted to determine the worst-case mode from all possible combinations between available modulations, data rates and antenna ports (if EUT with antenna diversity architecture).
- Following channel(s) was (were) selected for the final test as listed below.

MODE	FREQ. BAND (MHz)	AVAILABLE CHANNEL	TESTED CHANNEL	MODULATION TECHNOLOGY	MODULATION TYPE	DATA RATE (Mbps)
802.11a	5180-5320	36 to 64	64	OFDM	BPSK	6.0
802.11a	5500-5700	100 to 140	132	OFDM	BPSK	6.0



**BANDEDGE MEASUREMENT:**

- Pre-Scan has been conducted to determine the worst-case mode from all possible combinations between available modulations, data rates and antenna ports (if EUT with antenna diversity architecture).
- Following channel(s) was (were) selected for the final test as listed below.

MODE	FREQ. BAND (MHz)	AVAILABLE CHANNEL	TESTED CHANNEL	MODULATION TECHNOLOGY	MODULATION TYPE	DATA RATE (Mbps)
802.11a	5180-5320	36 to 64	36, 64	OFDM	BPSK	6.0
802.11a	5500-5700	100 to 140	100, 140	OFDM	BPSK	6.0

**ANTENNA PORT CONDUCTED MEASUREMENT:**

- This item includes all test value of each mode, but only includes spectrum plot of worst value of each mode.
- Pre-Scan has been conducted to determine the worst-case mode from all possible combinations between available modulations, data rates and antenna ports (if EUT with antenna diversity architecture).
- Following channel(s) was (were) selected for the final test as listed below.

MODE	FREQ. BAND (MHz)	AVAILABLE CHANNEL	TESTED CHANNEL	MODULATION TECHNOLOGY	MODULATION TYPE	DATA RATE (Mbps)
802.11a	5180-5320	36 to 64	36, 40, 48, 52, 60, 64	OFDM	BPSK	6.0
802.11a	5500-5700	100 to 140	100, 116, 132, 140	OFDM	BPSK	6.0

**TEST CONDITION:**

APPLICABLE TO	ENVIRONMENTAL CONDITIONS	INPUT POWER (SYSTEM)	TESTED BY
RE≥1G	25deg. C, 70%RH, 1006 hPa	120Vac, 60Hz	Lori Chiu
RE<1G	25deg. C, 70%RH, 1006 hPa	120Vac, 60Hz	Lori Chiu
PLC	22deg. C, 66%RH, 1017 hPa	120Vac, 60Hz	Dean Wang
APCM	25deg. C, 63%RH, 1014 hPa	120Vac, 60Hz	Lori Chiu



### 3.3 GENERAL DESCRIPTION OF APPLIED STANDARDS

The EUT is a RF Product. According to the specifications of the manufacturer, it must comply with the requirements of the following standards:

**FCC Part 15, Subpart E (15.407)**  
**ANSI C63.4-2003**

All test items have been performed and recorded as per the above standards.

**NOTE:** The EUT is also considered as a kind of computer peripheral, because the connection to computer is necessary for typical use. It has been verified to comply with the requirements of FCC Part 15, Subpart B, Class B (DoC). The test report has been issued separately.

### 3.4 DESCRIPTION OF SUPPORT UNITS

The EUT has been tested as an independent unit together with other necessary accessories or support units. The following support units or accessories were used to form a representative test configuration during the tests.

NO.	PRODUCT	BRAND	MODEL NO.	SERIAL NO.	FCC ID
1	NOTEBOOK	DELL	PP05L	12130898320	E2K24CLNS
2	PRINTER	EPSON	LQ-300+	DCGY054146	FCC DoC Approved
3	MODEM	ACEEX	1414V/3	0401008260	IFAXDM1414

NO.	SIGNAL CABLE DESCRIPTION OF THE ABOVE SUPPORT UNITS
1	NA
2	1.8m braid shielded wire, DB25 connector, w/o core.
3	1.2m braid shielded wire, DB25 & DB9 connector, w/o core.

**NOTE:** All power cords of the above support units are non-shielded (1.8m).

## 4. TEST TYPES AND RESULTS

### 4.1 RADIATED EMISSION MEASUREMENT

#### 4.1.1 LIMITS OF RADIATED EMISSION MEASUREMENT

Emissions radiated outside of the specified bands, shall be according to the general radiated limits in 15.209 as following:

FREQUENCIES (MHz)	FIELD STRENGTH (microvolts/meter)	MEASUREMENT DISTANCE (meters)
0.009 ~ 0.490	2400/F(kHz)	300
0.490 ~ 1.705	24000/F(kHz)	30
1.705 ~ 30.0	30	30
30 ~ 88	100	3
88 ~ 216	150	3
216 ~ 960	200	3
Above 960	500	3

**NOTE:**

1. The lower limit shall apply at the transition frequencies.
2. Emission level (dBuV/m) = 20 log Emission level (uV/m).
3. As shown in 15.35(b), for frequencies above 1000MHz, the field strength limits are based on average detector, however, the peak field strength of any emission shall not exceed the maximum permitted average limits, specified above by more than 20dB under any condition of modulation.

#### 4.1.2 LIMITS OF UNWANTED EMISSION OUT OF THE RESTRICTED BANDS

FREQUENCIES (MHz)	EIRP LIMIT (dBm)	EQUIVALENT FIELD STRENGTH AT 3m (dBµV/m) *NOTE
	PK	PK
5150 ~ 5350	-27	68.3
5470 ~ 5725	-27	68.3

**NOTE:**

The following formula is used to convert the equipment isotropic radiated power (eirp) to field strength:

$$E = \frac{1000000\sqrt{30P}}{3} \mu\text{V/m, where P is the eirp (Watts).}$$



#### 4.1.3 TEST INSTRUMENTS

DESCRIPTION & MANUFACTURER	MODEL NO.	SERIAL NO.	DATE OF CALIBRATION	DUE DATE OF CALIBRATION
Test Receiver ROHDE & SCHWARZ	ESIB7	100212	May 25, 2009	May 24, 2010
Spectrum Analyzer ROHDE & SCHWARZ	FSP40	100040	Jul. 07, 2009	Jul. 06, 2010
BILOG Antenna SCHWARZBECK	VULB9168	9168-156	Apr. 30, 2009	Apr. 29, 2010
HORN Antenna SCHWARZBECK	BBHA 9120 D	9120D-563	Aug. 10, 2009	Aug. 09, 2010
HORN Antenna SCHWARZBECK	BBHA 9170	BBHA9170242	Dec. 25, 2009	Dec. 24, 2010
Preamplifier Agilent	8449B	3008A01910	Sep. 11, 2009	Sep. 10, 2010
Preamplifier Agilent	8447D	2944A10638	Dec. 21, 2009	Dec. 20, 2010
RF signal cable HUBER+SUHNNER	SUCOFLEX 104	218190/4 231241/4	May 13, 2009	May 12, 2010
RF signal cable Worken	8D-FB	Cable-HYCH9-01	Aug. 17, 2009	Aug. 16, 2010
Software	ADT_Radiated_ V7.6.15.9.2	NA	NA	NA
Antenna Tower EMCO	2070/2080	512.835.4684	NA	NA
Turn Table EMCO	2087-2.03	NA	NA	NA
Antenna Tower & Turn Table Controller EMCO	2090	NA	NA	NA
26GHz ~ 40GHz Amplifier	EM26400	07026401	Aug. 27, 2009	Aug. 26, 2010

- NOTE:**
1. The calibration interval of the above test instruments is 12 months and the calibrations are traceable to NML/ROC and NIST/USA.
  2. The test was performed in HwaYa Chamber 9.
  3. The horn antenna and HP preamplifier (model: 8449B) are used only for the measurement of emission frequency above 1GHz if tested.
  4. The FCC Site Registration No. is 460141.
  5. The IC Site Registration No. is IC 7450F-4.

#### 4.1.4 TEST PROCEDURES

- a. The EUT was placed on the top of a rotating table 0.8 meters above the ground at a 3 meter semi-anechoic chamber. The table was rotated 360 degrees to determine the position of the highest radiation.
- b. The EUT was set 3 meters away from the interference-receiving antenna, which was mounted on the top of a variable-height antenna tower.
- c. The antenna is a broadband antenna, and its height is varied from one meter to four meters above the ground to determine the maximum value of the field strength. Both horizontal and vertical polarizations of the antenna are set to make the measurement.
- d. For each suspected emission, the EUT was arranged to its worst case and then the antenna was tuned to heights from 1 meter to 4 meters and the rotatable table was turned from 0 degrees to 360 degrees to find the maximum reading.
- e. The test-receiver system was set to Peak Detect Function and Specified Bandwidth with Maximum Hold Mode.
- f. If the emission level of the EUT in peak mode was 10dB lower than the limit specified, then testing could be stopped and the peak values of the EUT would be reported. Otherwise the emissions that did not have 10dB margin would be re-tested one by one using peak, quasi-peak or average method as specified and then reported in a data sheet.

**NOTE:**

1. The resolution bandwidth and video bandwidth of test receiver/spectrum analyzer is 120kHz for Peak detection (PK) and Quasi-peak detection (QP) at frequency below 1GHz.
2. The resolution bandwidth of test receiver/spectrum analyzer is 1MHz and video bandwidth is 3MHz for Peak detection at frequency above 1GHz.
3. The resolution bandwidth of test receiver/spectrum analyzer is 1MHz and the video bandwidth is 10Hz for Average detection (AV) at frequency above 1GHz.
4. All modes of operation were investigated and the worst-case emissions are reported.

#### 4.1.5 DEVIATION FROM TEST STANDARD

No deviation.

#### 4.1.6 TEST SETUP

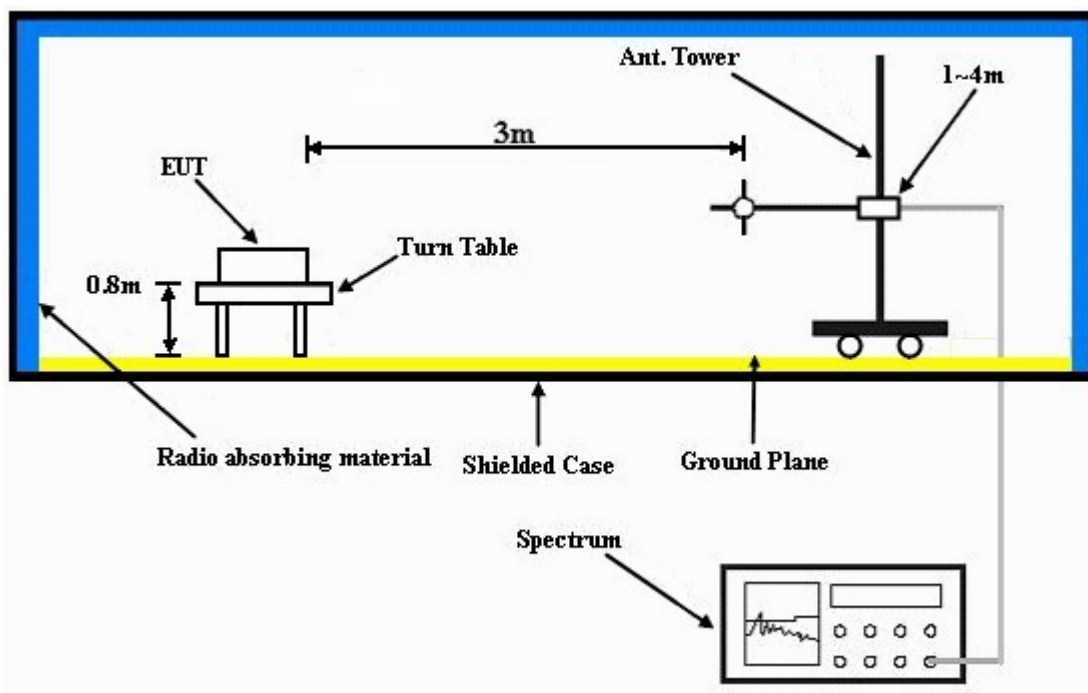

For the actual test configuration, please refer to the attached file (Test Setup Photo).

#### 4.1.7 EUT OPERATING CONDITION

- a. Connected the EUT to a notebook via USB cable and placed on a testing table.
- b. The EUT runs a test program (provided by manufacture) to transmit at specific channel.
- c. The necessary accessories enable the system in full functions.



A D T

### 4.1.8 TEST RESULTS

#### ABOVE 1GHz WORST-CASE DATA : 802.11a

EUT TEST CONDITION		MEASUREMENT DETAIL	
CHANNEL	Channel 36	FREQUENCY RANGE	1 ~ 40GHz
INPUT POWER (SYSTEM)	120Vac, 60 Hz	DETECTOR FUNCTION	Peak (PK) Average (AV)
ENVIRONMENTAL CONDITIONS	25deg. C, 70%RH 1006 hPa	TESTED BY	Lori Chiu

ANTENNA POLARITY & TEST DISTANCE: HORIZONTAL AT 3 M								
NO.	FREQ. (MHz)	EMISSION LEVEL (dBuV/m)	LIMIT (dBuV/m)	MARGIN (dB)	ANTENNA HEIGHT (m)	TABLE ANGLE (Degree)	RAW VALUE (dBuV)	CORRECTION FACTOR (dB/m)
1	5150.00	53.1 PK	74.0	-20.9	1.19 H	200	14.10	39.00
2	5150.00	36.0 AV	54.0	-18.0	1.19 H	200	-3.00	39.00
3	*5180.00	96.2 PK			1.19 H	200	57.20	39.00
4	*5180.00	85.6 AV			1.19 H	200	46.60	39.00
5	#10360.00	58.1 PK	68.3	-10.2	1.32 H	179	9.40	48.70
ANTENNA POLARITY & TEST DISTANCE: VERTICAL AT 3 M								
NO.	FREQ. (MHz)	EMISSION LEVEL (dBuV/m)	LIMIT (dBuV/m)	MARGIN (dB)	ANTENNA HEIGHT (m)	TABLE ANGLE (Degree)	RAW VALUE (dBuV)	CORRECTION FACTOR (dB/m)
1	5150.00	57.9 PK	74.0	-16.1	1.01 V	28	18.90	39.00
2	5150.00	38.0 AV	54.0	-16.0	1.01 V	28	-1.00	39.00
3	*5180.00	100.4 PK			1.01 V	28	61.40	39.00
4	*5180.00	90.1 AV			1.01 V	28	51.10	39.00
5	#10360.00	58.6 PK	68.3	-9.7	1.23 V	200	9.90	48.70

- REMARKS:**
1. Emission level (dBuV/m) = Raw Value (dBuV) + Correction Factor (dB/m).
  2. Correction Factor (dB/m) = Antenna Factor (dB/m) + Cable Factor (dB).
  3. The other emission levels were very low against the limit.
  4. Margin value = Emission level – Limit value.
  5. “ \* “: Fundamental frequency.
  6. “#”:The radiated frequency is out the restricted band.





A D T

EUT TEST CONDITION		MEASUREMENT DETAIL	
CHANNEL	Channel 40	FREQUENCY RANGE	1 ~ 40GHz
INPUT POWER (SYSTEM)	120Vac, 60 Hz	DETECTOR FUNCTION	Peak (PK) Average (AV)
ENVIRONMENTAL CONDITIONS	25deg. C, 70%RH 1006 hPa	TESTED BY	Lori Chiu

ANTENNA POLARITY & TEST DISTANCE: HORIZONTAL AT 3 M								
NO.	FREQ. (MHz)	EMISSION LEVEL (dBuV/m)	LIMIT (dBuV/m)	MARGIN (dB)	ANTENNA HEIGHT (m)	TABLE ANGLE (Degree)	RAW VALUE (dBuV)	CORRECTION FACTOR (dB/m)
1	*5200.00	96.3 PK			1.02 H	118	57.30	39.00
2	*5200.00	86.2 AV			1.02 H	118	47.20	39.00
3	#10400.00	57.6 PK	68.3	-10.7	1.20 H	15	8.90	48.70
ANTENNA POLARITY & TEST DISTANCE: VERTICAL AT 3 M								
NO.	FREQ. (MHz)	EMISSION LEVEL (dBuV/m)	LIMIT (dBuV/m)	MARGIN (dB)	ANTENNA HEIGHT (m)	TABLE ANGLE (Degree)	RAW VALUE (dBuV)	CORRECTION FACTOR (dB/m)
1	*5200.00	100.2 PK			1.22 V	207	61.20	39.00
2	*5200.00	89.3 AV			1.22 V	207	50.30	39.00
3	#10400.00	57.9 PK	68.3	-10.4	1.26 V	289	9.20	48.70

- REMARKS:**
1. Emission level (dBuV/m) = Raw Value (dBuV) + Correction Factor (dB/m).
  2. Correction Factor (dB/m) = Antenna Factor (dB/m) + Cable Factor (dB).
  3. The other emission levels were very low against the limit.
  4. Margin value = Emission level – Limit value.
  5. “ \* “: Fundamental frequency.
  6. “#”: The radiated frequency is out the restricted band.



A D T

EUT TEST CONDITION		MEASUREMENT DETAIL	
CHANNEL	Channel 48	FREQUENCY RANGE	1 ~ 40GHz
INPUT POWER (SYSTEM)	120Vac, 60 Hz	DETECTOR FUNCTION	Peak (PK) Average (AV)
ENVIRONMENTAL CONDITIONS	25deg. C, 70%RH 1006 hPa	TESTED BY	Lori Chiu

ANTENNA POLARITY & TEST DISTANCE: HORIZONTAL AT 3 M								
NO.	FREQ. (MHz)	EMISSION LEVEL (dBuV/m)	LIMIT (dBuV/m)	MARGIN (dB)	ANTENNA HEIGHT (m)	TABLE ANGLE (Degree)	RAW VALUE (dBuV)	CORRECTION FACTOR (dB/m)
1	*5240.00	97.2 PK			1.06 H	318	58.10	39.10
2	*5240.00	86.3 AV			1.06 H	318	47.20	39.10
3	#10480.00	57.9 PK	68.3	-10.4	1.21 H	147	9.00	48.90
ANTENNA POLARITY & TEST DISTANCE: VERTICAL AT 3 M								
NO.	FREQ. (MHz)	EMISSION LEVEL (dBuV/m)	LIMIT (dBuV/m)	MARGIN (dB)	ANTENNA HEIGHT (m)	TABLE ANGLE (Degree)	RAW VALUE (dBuV)	CORRECTION FACTOR (dB/m)
1	*5240.00	101.2 PK			1.57 V	166	62.10	39.10
2	*5240.00	90.7 AV			1.57 V	166	51.60	39.10
3	#10480.00	58.6 PK	68.3	-9.7	1.02 V	160	9.70	48.90

- REMARKS:**
1. Emission level (dBuV/m) = Raw Value (dBuV) + Correction Factor (dB/m).
  2. Correction Factor (dB/m) = Antenna Factor (dB/m) + Cable Factor (dB).
  3. The other emission levels were very low against the limit.
  4. Margin value = Emission level – Limit value.
  5. “ \* “: Fundamental frequency.
  6. “#”: The radiated frequency is out the restricted band.



A D T

EUT TEST CONDITION		MEASUREMENT DETAIL	
CHANNEL	Channel 52	FREQUENCY RANGE	1 ~ 40GHz
INPUT POWER (SYSTEM)	120Vac, 60 Hz	DETECTOR FUNCTION	Peak (PK) Average (AV)
ENVIRONMENTAL CONDITIONS	25deg. C, 70%RH 1006 hPa	TESTED BY	Lori Chiu

ANTENNA POLARITY & TEST DISTANCE: HORIZONTAL AT 3 M								
NO.	FREQ. (MHz)	EMISSION LEVEL (dBuV/m)	LIMIT (dBuV/m)	MARGIN (dB)	ANTENNA HEIGHT (m)	TABLE ANGLE (Degree)	RAW VALUE (dBuV)	CORRECTION FACTOR (dB/m)
1	*5260.00	98.2 PK			1.00 H	133	59.10	39.10
2	*5260.00	87.3 AV			1.00 H	133	48.20	39.10
3	#10520.00	58.2 PK	68.3	-10.1	1.33 H	154	9.20	49.00
ANTENNA POLARITY & TEST DISTANCE: VERTICAL AT 3 M								
NO.	FREQ. (MHz)	EMISSION LEVEL (dBuV/m)	LIMIT (dBuV/m)	MARGIN (dB)	ANTENNA HEIGHT (m)	TABLE ANGLE (Degree)	RAW VALUE (dBuV)	CORRECTION FACTOR (dB/m)
1	*5260.00	101.2 PK			1.00 V	133	62.10	39.10
2	*5260.00	90.1 AV			1.00 V	133	51.00	39.10
3	#10520.00	57.6 PK	68.3	-10.7	1.14 V	360	8.60	49.00

- REMARKS:**
1. Emission level (dBuV/m) = Raw Value (dBuV) + Correction Factor (dB/m).
  2. Correction Factor (dB/m) = Antenna Factor (dB/m) + Cable Factor (dB).
  3. The other emission levels were very low against the limit.
  4. Margin value = Emission level – Limit value.
  5. “ \* “: Fundamental frequency.
  6. “#”: The radiated frequency is out the restricted band.



A D T

EUT TEST CONDITION		MEASUREMENT DETAIL	
CHANNEL	Channel 60	FREQUENCY RANGE	1 ~ 40GHz
INPUT POWER (SYSTEM)	120Vac, 60 Hz	DETECTOR FUNCTION	Peak (PK) Average (AV)
ENVIRONMENTAL CONDITIONS	25deg. C, 70%RH 1006 hPa	TESTED BY	Lori Chiu

ANTENNA POLARITY & TEST DISTANCE: HORIZONTAL AT 3 M								
NO.	FREQ. (MHz)	EMISSION LEVEL (dBuV/m)	LIMIT (dBuV/m)	MARGIN (dB)	ANTENNA HEIGHT (m)	TABLE ANGLE (Degree)	RAW VALUE (dBuV)	CORRECTION FACTOR (dB/m)
1	*5300.00	96.6 PK			1.23 H	50	57.40	39.20
2	*5300.00	86.2 AV			1.23 H	50	47.00	39.20
3	10600.00	56.8 PK	74.0	-17.2	1.00 H	208	7.60	49.20
4	10600.00	44.0 AV	54.0	-10.0	1.00 H	208	-5.20	49.20
ANTENNA POLARITY & TEST DISTANCE: VERTICAL AT 3 M								
NO.	FREQ. (MHz)	EMISSION LEVEL (dBuV/m)	LIMIT (dBuV/m)	MARGIN (dB)	ANTENNA HEIGHT (m)	TABLE ANGLE (Degree)	RAW VALUE (dBuV)	CORRECTION FACTOR (dB/m)
1	*5300.00	101.5 PK			1.11 V	348	62.30	39.20
2	*5300.00	90.2 AV			1.11 V	348	51.00	39.20
3	10600.00	57.9 PK	74.0	-16.1	1.00 V	166	8.70	49.20
4	10600.00	45.1 AV	54.0	-8.9	1.00 V	166	-4.10	49.20

- REMARKS:**
1. Emission level (dBuV/m) = Raw Value (dBuV) + Correction Factor (dB/m).
  2. Correction Factor (dB/m) = Antenna Factor (dB/m) + Cable Factor (dB).
  3. The other emission levels were very low against the limit.
  4. Margin value = Emission level – Limit value.
  5. “ \* “: Fundamental frequency.



A D T

EUT TEST CONDITION		MEASUREMENT DETAIL	
CHANNEL	Channel 64	FREQUENCY RANGE	1 ~ 40GHz
INPUT POWER (SYSTEM)	120Vac, 60 Hz	DETECTOR FUNCTION	Peak (PK) Average (AV)
ENVIRONMENTAL CONDITIONS	25deg. C, 70%RH 1006 hPa	TESTED BY	Lori Chiu

ANTENNA POLARITY & TEST DISTANCE: HORIZONTAL AT 3 M								
NO.	FREQ. (MHz)	EMISSION LEVEL (dBuV/m)	LIMIT (dBuV/m)	MARGIN (dB)	ANTENNA HEIGHT (m)	TABLE ANGLE (Degree)	RAW VALUE (dBuV)	CORRECTION FACTOR (dB/m)
1	*5320.00	97.3 PK			1.16 H	244	58.10	39.20
2	*5320.00	86.0 AV			1.16 H	244	46.80	39.20
3	5350.00	54.1 PK	74.0	-19.9	1.16 H	244	14.80	39.30
4	5350.00	36.8 AV	54.0	-17.2	1.16 H	244	-2.50	39.30
5	10640.00	57.2 PK	74.0	-16.8	1.01 H	5	7.90	49.30
6	10640.00	44.3 AV	54.0	-9.7	1.01 H	5	-5.00	49.30
ANTENNA POLARITY & TEST DISTANCE: VERTICAL AT 3 M								
NO.	FREQ. (MHz)	EMISSION LEVEL (dBuV/m)	LIMIT (dBuV/m)	MARGIN (dB)	ANTENNA HEIGHT (m)	TABLE ANGLE (Degree)	RAW VALUE (dBuV)	CORRECTION FACTOR (dB/m)
1	*5320.00	102.4 PK			1.00 V	3	63.20	39.20
2	*5320.00	91.5 AV			1.00 V	3	52.30	39.20
3	5350.00	58.6 PK	74.0	-15.4	1.00 V	3	19.30	39.30
4	5350.00	40.2 AV	54.0	-13.8	1.00 V	3	0.90	39.30
5	10640.00	56.9 PK	74.0	-17.1	1.01 V	128	7.60	49.30
6	10640.00	45.9 AV	54.0	-8.1	1.01 V	128	-3.40	49.30

- REMARKS:**
1. Emission level (dBuV/m) = Raw Value (dBuV) + Correction Factor (dB/m).
  2. Correction Factor (dB/m) = Antenna Factor (dB/m) + Cable Factor (dB).
  3. The other emission levels were very low against the limit.
  4. Margin value = Emission level – Limit value.
  5. “ \* “: Fundamental frequency.



A D T

EUT TEST CONDITION		MEASUREMENT DETAIL	
CHANNEL	Channel 100	FREQUENCY RANGE	1 ~ 40GHz
INPUT POWER (SYSTEM)	120Vac, 60 Hz	DETECTOR FUNCTION	Peak (PK) Average (AV)
ENVIRONMENTAL CONDITIONS	25deg. C, 70%RH 1006 hPa	TESTED BY	Lori Chiu

ANTENNA POLARITY & TEST DISTANCE: HORIZONTAL AT 3 M								
NO.	FREQ. (MHz)	EMISSION LEVEL (dBuV/m)	LIMIT (dBuV/m)	MARGIN (dB)	ANTENNA HEIGHT (m)	TABLE ANGLE (Degree)	RAW VALUE (dBuV)	CORRECTION FACTOR (dB/m)
1	5460.00	50.1 PK	74.0	-23.9	1.00 H	169	10.70	39.40
2	5460.00	37.2 AV	54.0	-16.8	1.00 H	169	-2.20	39.40
3	#5470.00	52.1 PK	68.3	-16.2	1.00 H	169	12.70	39.40
4	*5500.00	95.0 PK			1.00 H	169	55.50	39.50
5	*5500.00	85.1 AV			1.00 H	169	45.60	39.50
6	11000.00	58.2 PK	74.0	-15.8	1.34 H	9	8.40	49.80
7	11000.00	44.9 AV	54.0	-9.1	1.34 H	9	-4.90	49.80
ANTENNA POLARITY & TEST DISTANCE: VERTICAL AT 3 M								
NO.	FREQ. (MHz)	EMISSION LEVEL (dBuV/m)	LIMIT (dBuV/m)	MARGIN (dB)	ANTENNA HEIGHT (m)	TABLE ANGLE (Degree)	RAW VALUE (dBuV)	CORRECTION FACTOR (dB/m)
1	5460.00	56.0 PK	74.0	-18.0	1.00 V	277	16.60	39.40
2	5460.00	40.1 AV	54.0	-13.9	1.00 V	277	0.70	39.40
3	#5470.00	59.2 PK	68.3	-9.1	1.00 V	277	19.80	39.40
4	*5500.00	101.7 PK			1.00 V	277	62.20	39.50
5	*5500.00	91.5 AV			1.00 V	277	52.00	39.50
6	11000.00	58.6 PK	74.0	-15.4	1.01 V	12	8.80	49.80
7	11000.00	45.6 AV	54.0	-8.4	1.01 V	12	-4.2	49.80

- REMARKS:**
1. Emission level (dBuV/m) = Raw Value (dBuV) + Correction Factor (dB/m).
  2. Correction Factor (dB/m) = Antenna Factor (dB/m) + Cable Factor (dB).
  3. The other emission levels were very low against the limit.
  4. Margin value = Emission level – Limit value.
  5. “ \* “: Fundamental frequency.
  6. “#”: The radiated frequency is out the restricted band.



A D T

EUT TEST CONDITION		MEASUREMENT DETAIL	
CHANNEL	Channel 116	FREQUENCY RANGE	1 ~ 40GHz
INPUT POWER (SYSTEM)	120Vac, 60 Hz	DETECTOR FUNCTION	Peak (PK) Average (AV)
ENVIRONMENTAL CONDITIONS	25deg. C, 70%RH 1006 hPa	TESTED BY	Lori Chiu

ANTENNA POLARITY & TEST DISTANCE: HORIZONTAL AT 3 M								
NO.	FREQ. (MHz)	EMISSION LEVEL (dBuV/m)	LIMIT (dBuV/m)	MARGIN (dB)	ANTENNA HEIGHT (m)	TABLE ANGLE (Degree)	RAW VALUE (dBuV)	CORRECTION FACTOR (dB/m)
1	*5580.00	94.1 PK			1.22 H	180	54.50	39.60
2	*5580.00	83.9 AV			1.22 H	180	44.30	39.60
3	11160.00	58.1 PK	74.0	-15.9	1.00 H	157	8.00	50.10
4	11160.00	45.2 AV	54.0	-8.8	1.00 H	157	-4.90	50.10
ANTENNA POLARITY & TEST DISTANCE: VERTICAL AT 3 M								
NO.	FREQ. (MHz)	EMISSION LEVEL (dBuV/m)	LIMIT (dBuV/m)	MARGIN (dB)	ANTENNA HEIGHT (m)	TABLE ANGLE (Degree)	RAW VALUE (dBuV)	CORRECTION FACTOR (dB/m)
1	*5580.00	101.0 PK			1.01 V	141	61.40	39.60
2	*5580.00	89.2 AV			1.01 V	141	49.60	39.60
3	11160.00	58.0 PK	74.0	-16.0	1.23 V	35	7.90	50.10
4	11160.00	45.9 AV	54.0	-8.1	1.23 V	35	-4.20	50.10

- REMARKS:**
1. Emission level (dBuV/m) = Raw Value (dBuV) + Correction Factor (dB/m).
  2. Correction Factor (dB/m) = Antenna Factor (dB/m) + Cable Factor (dB).
  3. The other emission levels were very low against the limit.
  4. Margin value = Emission level – Limit value.
  5. “ \* “: Fundamental frequency.



A D T

EUT TEST CONDITION		MEASUREMENT DETAIL	
CHANNEL	Channel 132	FREQUENCY RANGE	1 ~ 40GHz
INPUT POWER (SYSTEM)	120Vac, 60 Hz	DETECTOR FUNCTION	Peak (PK) Average (AV)
ENVIRONMENTAL CONDITIONS	25deg. C, 70%RH 1006 hPa	TESTED BY	Lori Chiu

ANTENNA POLARITY & TEST DISTANCE: HORIZONTAL AT 3 M								
NO.	FREQ. (MHz)	EMISSION LEVEL (dBuV/m)	LIMIT (dBuV/m)	MARGIN (dB)	ANTENNA HEIGHT (m)	TABLE ANGLE (Degree)	RAW VALUE (dBuV)	CORRECTION FACTOR (dB/m)
1	*5660.00	95.1 PK			1.00 H	341	55.30	39.80
2	*5660.00	84.0 AV			1.00 H	341	44.20	39.80
3	11320.00	58.2 PK	74.0	-15.8	1.01 H	179	7.90	50.30
4	11320.00	45.1 AV	54.0	-8.9	1.01 H	179	-5.20	50.30
ANTENNA POLARITY & TEST DISTANCE: VERTICAL AT 3 M								
NO.	FREQ. (MHz)	EMISSION LEVEL (dBuV/m)	LIMIT (dBuV/m)	MARGIN (dB)	ANTENNA HEIGHT (m)	TABLE ANGLE (Degree)	RAW VALUE (dBuV)	CORRECTION FACTOR (dB/m)
1	*5660.00	101.1 PK			1.11 V	50	61.30	39.80
2	*5660.00	90.2 AV			1.11 V	50	50.40	39.80
3	11320.00	59.0 PK	74.0	-15.0	1.00 V	145	8.70	50.30
4	11320.00	45.1 AV	54.0	-8.9	1.00 V	145	-5.20	50.30

- REMARKS:**
1. Emission level (dBuV/m) = Raw Value (dBuV) + Correction Factor (dB/m).
  2. Correction Factor (dB/m) = Antenna Factor (dB/m) + Cable Factor (dB).
  3. The other emission levels were very low against the limit.
  4. Margin value = Emission level – Limit value.
  5. “ \* “: Fundamental frequency.





A D T

EUT TEST CONDITION		MEASUREMENT DETAIL	
CHANNEL	Channel 140	FREQUENCY RANGE	1 ~ 40GHz
INPUT POWER (SYSTEM)	120Vac, 60 Hz	DETECTOR FUNCTION	Peak (PK) Average (AV)
ENVIRONMENTAL CONDITIONS	25deg. C, 70%RH 1006 hPa	TESTED BY	Lori Chiu

ANTENNA POLARITY & TEST DISTANCE: HORIZONTAL AT 3 M								
NO.	FREQ. (MHz)	EMISSION LEVEL (dBuV/m)	LIMIT (dBuV/m)	MARGIN (dB)	ANTENNA HEIGHT (m)	TABLE ANGLE (Degree)	RAW VALUE (dBuV)	CORRECTION FACTOR (dB/m)
1	*5700.00	95.1 PK			1.01 H	200	55.20	39.90
2	*5700.00	84.9 AV			1.01 H	200	45.00	39.90
3	#5725.00	54.2 PK	68.3	-14.1	1.00 H	197	14.20	40.00
4	11400.00	50.4 PK	74.0	-15.6	1.20 H	154	8.00	50.40
5	11400.00	50.4 AV	54.0	-8.3	1.20 H	154	-7.40	50.40
ANTENNA POLARITY & TEST DISTANCE: VERTICAL AT 3 M								
NO.	FREQ. (MHz)	EMISSION LEVEL (dBuV/m)	LIMIT (dBuV/m)	MARGIN (dB)	ANTENNA HEIGHT (m)	TABLE ANGLE (Degree)	RAW VALUE (dBuV)	CORRECTION FACTOR (dB/m)
1	*5700.00	100.1 PK			1.00 V	79	60.20	39.90
2	*5700.00	90.0 AV			1.00 V	79	50.10	39.90
3	#5725.00	58.6 PK	68.3	-9.7	1.00 V	79	18.60	40.00
4	11140.00	50.1 PK	74.0	-14.8	1.01 V	157	9.1	50.10
5	11140.00	50.1 AV	54.0	-8.9	1.01 V	157	-5.0	50.10

- REMARKS:**
1. Emission level (dBuV/m) = Raw Value (dBuV) + Correction Factor (dB/m).
  2. Correction Factor (dB/m) = Antenna Factor (dB/m) + Cable Factor (dB).
  3. The other emission levels were very low against the limit.
  4. Margin value = Emission level – Limit value.
  5. “ \* “: Fundamental frequency.
  6. "#":The radiated frequency is out the restricted band.



A D T

BELOW 1GHz WORST-CASE DATA : 802.11a (Frequency: 5180-5320MHz)

EUT TEST CONDITION		MEASUREMENT DETAIL	
CHANNEL	Channel 64	FREQUENCY RANGE	Below 1000MHz
INPUT POWER (SYSTEM)	120Vac, 60 Hz	DETECTOR FUNCTION	Quasi-Peak
ENVIRONMENTAL CONDITIONS	25deg. C, 70%RH 1006 hPa	TESTED BY	Lori Chiu

ANTENNA POLARITY & TEST DISTANCE: HORIZONTAL AT 3 M								
NO.	FREQ. (MHz)	EMISSION LEVEL (dBuV/m)	LIMIT (dBuV/m)	MARGIN (dB)	ANTENNA HEIGHT (m)	TABLE ANGLE (Degree)	RAW VALUE (dBuV)	CORRECTION FACTOR (dB/m)
1	59.06	31.5 QP	40.0	-8.5	2.00 H	163	18.00	13.50
2	84.34	30.5 QP	40.0	-9.5	2.00 H	1	21.90	8.60
3	201.00	36.7 QP	43.5	-6.8	2.00 H	124	26.00	10.70
4	307.93	36.4 QP	46.0	-9.6	1.00 H	142	22.50	13.90
5	335.15	33.2 QP	46.0	-12.8	1.00 H	163	18.70	14.50
6	500.42	33.3 QP	46.0	-12.7	1.00 H	175	14.00	19.30
ANTENNA POLARITY & TEST DISTANCE: VERTICAL AT 3 M								
NO.	FREQ. (MHz)	EMISSION LEVEL (dBuV/m)	LIMIT (dBuV/m)	MARGIN (dB)	ANTENNA HEIGHT (m)	TABLE ANGLE (Degree)	RAW VALUE (dBuV)	CORRECTION FACTOR (dB/m)
1	64.90	33.2 QP	40.0	-6.8	1.00 V	7	20.70	12.50
2	214.61	34.0 QP	43.5	-9.5	1.00 V	220	22.70	11.30
3	500.42	36.1 QP	46.0	-9.9	1.00 V	136	16.80	19.30
4	842.61	32.1 QP	46.0	-13.9	1.00 V	160	6.50	25.60
5	889.28	33.9 QP	46.0	-12.1	1.00 V	154	7.80	26.10
6	935.94	34.7 QP	46.0	-11.3	1.00 V	172	8.30	26.40

- REMARKS:**
1. Emission level (dBuV/m) = Raw Value (dBuV) + Correction Factor (dB/m).
  2. Correction Factor (dB/m) = Antenna Factor (dB/m) + Cable Factor (dB).
  3. The other emission levels were very low against the limit.
  4. Margin value = Emission level – Limit value.



A D T

## 802.11a (Frequency: 5500-5700MHz)

EUT TEST CONDITION		MEASUREMENT DETAIL	
CHANNEL	Channel 132	FREQUENCY RANGE	Below 1000MHz
INPUT POWER (SYSTEM)	120Vac, 60 Hz	DETECTOR FUNCTION	Quasi-Peak
ENVIRONMENTAL CONDITIONS	25deg. C, 70%RH 1006 hPa	TESTED BY	Lori Chiu

ANTENNA POLARITY & TEST DISTANCE: HORIZONTAL AT 3 M								
NO.	FREQ. (MHz)	EMISSION LEVEL (dBuV/m)	LIMIT (dBuV/m)	MARGIN (dB)	ANTENNA HEIGHT (m)	TABLE ANGLE (Degree)	RAW VALUE (dBuV)	CORRECTION FACTOR (dB/m)
1	86.28	31.4 QP	40.0	-8.6	2.00 H	358	22.60	8.80
2	148.50	31.0 QP	43.5	-12.5	1.50 H	298	17.30	13.70
3	201.00	36.8 QP	43.5	-6.7	1.50 H	127	26.10	10.70
4	305.99	38.1 QP	46.0	-7.9	1.00 H	139	24.20	13.90
5	333.21	33.3 QP	46.0	-12.7	1.00 H	85	18.80	14.50
6	467.36	32.6 QP	46.0	-13.4	2.00 H	244	14.30	18.30
ANTENNA POLARITY & TEST DISTANCE: VERTICAL AT 3 M								
NO.	FREQ. (MHz)	EMISSION LEVEL (dBuV/m)	LIMIT (dBuV/m)	MARGIN (dB)	ANTENNA HEIGHT (m)	TABLE ANGLE (Degree)	RAW VALUE (dBuV)	CORRECTION FACTOR (dB/m)
1	66.84	32.9 QP	40.0	-7.1	1.00 V	295	20.70	12.20
2	222.38	34.2 QP	46.0	-11.8	1.00 V	244	22.60	11.60
3	862.06	34.1 QP	46.0	-11.9	2.00 V	163	8.30	25.80
4	889.28	35.4 QP	46.0	-10.6	1.00 V	172	9.30	26.10
5	920.38	35.2 QP	46.0	-10.8	1.00 V	91	8.90	26.30
6	947.60	33.5 QP	46.0	-12.5	1.50 V	52	7.00	26.50

- REMARKS:**
1. Emission level (dBuV/m) = Raw Value (dBuV) + Correction Factor (dB/m).
  2. Correction Factor (dB/m) = Antenna Factor (dB/m) + Cable Factor (dB).
  3. The other emission levels were very low against the limit.
  4. Margin value = Emission level – Limit value.

## 4.2 CONDUCTED EMISSION MEASUREMENT

### 4.2.1 LIMITS OF CONDUCTED EMISSION MEASUREMENT

FREQUENCY OF EMISSION (MHz)	CONDUCTED LIMIT (dB $\mu$ V)	
	Quasi-peak	Average
0.15 ~ 0.5	66 to 56	56 to 46
0.5 ~ 5	56	46
5 ~ 30	60	50

- NOTE:**
1. The lower limit shall apply at the transition frequencies.
  2. The limit decreases in line with the logarithm of the frequency in the range of 0.15 to 0.50MHz.
  3. All emanations from a class A/B digital device or system, including any network of conductors and apparatus connected thereto, shall not exceed the level of field strengths specified above.

### 4.2.2 TEST INSTRUMENTS

DESCRIPTION & MANUFACTURER	MODEL NO.	SERIAL NO.	DATE OF CALIBRATION	DUE DATE OF CALIBRATION
Test Receiver ROHDE & SCHWARZ	ESCS30	100288	Sep. 24, 2009	Sep. 23, 2010
RF signal cable Woken	5D-FB	Cable-HYCO2-01	Dec. 31, 2008	Dec. 30, 2009
LISN ROHDE & SCHWARZ	ESH2-Z5	100100	Dec. 29, 2008	Dec. 28, 2009
LISN ROHDE & SCHWARZ	ESH3-Z5	100311	Jul. 29, 2009	Jul. 28, 2010
Software ADT	ADT_Cond_ V7.3.7	NA	NA	NA

- NOTE:**
1. The calibration interval of the above test instruments is 12 months and the calibrations are traceable to NML/ROC and NIST/USA.
  2. The test was performed in HwaYa Shielded Room 2.
  3. The VCCI Site Registration No. is C-2047.

#### 4.2.3 TEST PROCEDURES

- a. The EUT was placed 0.4 meters from the conducting wall of the shielded room with EUT being connected to the power mains through a line impedance stabilization network (LISN). Other support units were connected to the power mains through another LISN. The two LISNs provide 50 ohm/ 50uH of coupling impedance for the measuring instrument.
- b. Both lines of the power mains connected to the EUT were checked for maximum conducted interference.
- c. The frequency range from 150kHz to 30MHz was searched. Emission levels under (Limit - 20dB) was not recorded.

**NOTE:** All modes of operation were investigated and the worst-case emissions are reported.

#### 4.2.4 DEVIATION FROM TEST STANDARD

No deviation.

#### 4.2.5 TEST SETUP

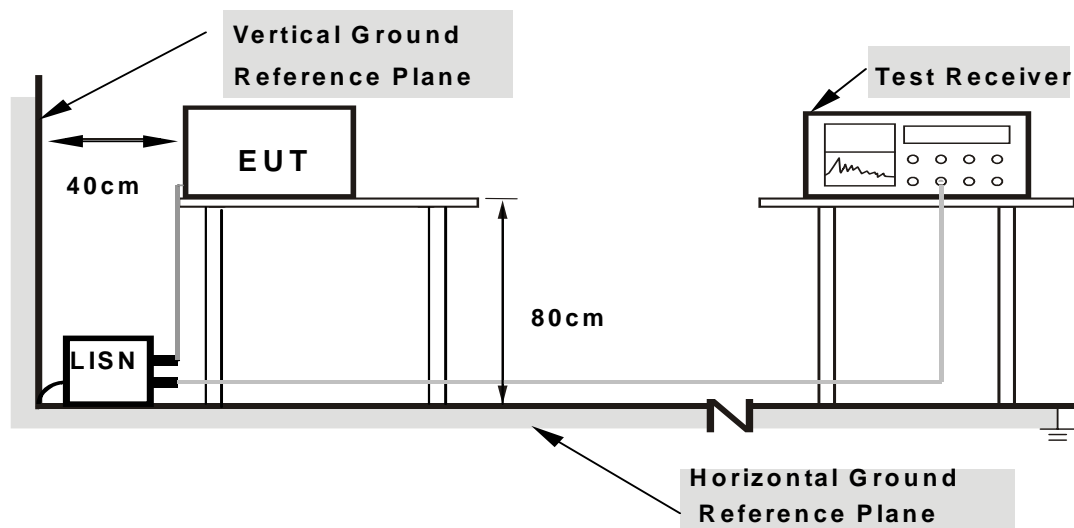

**Note: 1.Support units were connected to second LISN.**

**2.Both of LISNs (AMN) are 80 cm from EUT and at least 80 from other units and other metal planes**

For the actual test configuration, please refer to the attached file (Test Setup Photo).

#### 4.2.6 EUT OPERATING CONDITIONS

Same as 4.1.6.



A D T

## 4.2.7 TEST RESULTS

### CONDUCTED WORST-CASE DATA :

802.11a (Frequency: 5180-5320MHz)

PHASE	Line 1	6dB BANDWIDTH	9kHz
-------	--------	---------------	------

No	Freq. [MHz]	Corr. Factor (dB)	Reading Value [dB (uV)]		Emission Level [dB (uV)]		Limit [dB (uV)]		Margin (dB)	
			Q.P.	AV.	Q.P.	AV.	Q.P.	AV.	Q.P.	AV.
1	0.154	0.16	48.99	-	49.15	-	65.79	55.79	-16.64	-
2	0.185	0.16	43.12	-	43.28	-	64.25	54.25	-20.97	-
3	0.216	0.16	39.72	-	39.88	-	62.96	52.96	-23.07	-
4	0.459	0.18	34.00	-	34.18	-	56.72	46.72	-22.53	-
5	1.320	0.26	24.60	-	24.86	-	56.00	46.00	-31.14	-
6	15.359	0.51	35.27	-	35.78	-	60.00	50.00	-24.22	-

- REMARKS:**
1. Q.P. and AV. are abbreviations of quasi-peak and average individually.
  2. "-": The Quasi-peak reading value also meets average limit and measurement with the average detector is unnecessary.
  3. The emission levels of other frequencies were very low against the limit.
  4. Margin value = Emission level - Limit value
  5. Correction factor = Insertion loss + Cable loss
  6. Emission Level = Correction Factor + Reading Value.

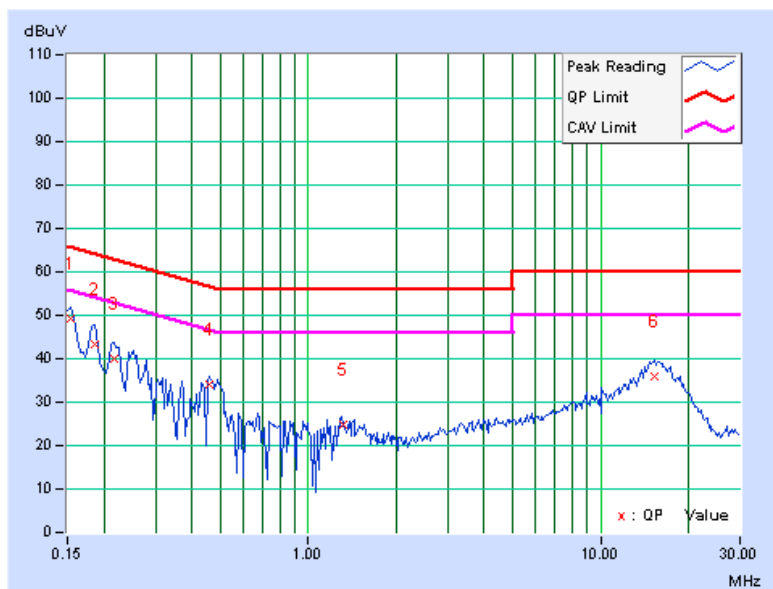



A D T

PHASE	Line 2	6dB BANDWIDTH	9kHz
-------	--------	---------------	------

No	Freq. [MHz]	Corr. Factor (dB)	Reading Value		Emission Level		Limit		Margin	
			[dB (uV)]		[dB (uV)]		[dB (uV)]		(dB)	
			Q.P.	AV.	Q.P.	AV.	Q.P.	AV.	Q.P.	AV.
1	0.155	0.13	48.73	-	48.86	-	65.74	55.74	-16.89	-
2	0.216	0.13	41.10	-	41.23	-	62.96	52.96	-21.72	-
3	0.431	0.16	36.03	-	36.19	-	57.23	47.23	-21.04	-
4	0.490	0.17	35.48	-	35.65	-	56.17	46.17	-20.52	-
5	1.719	0.28	25.86	-	26.14	-	56.00	46.00	-29.86	-
6	16.051	0.71	34.87	-	35.58	-	60.00	50.00	-24.42	-

- REMARKS:**
1. Q.P. and AV. are abbreviations of quasi-peak and average individually.
  2. "-": The Quasi-peak reading value also meets average limit and measurement with the average detector is unnecessary.
  3. The emission levels of other frequencies were very low against the limit.
  4. Margin value = Emission level - Limit value
  5. Correction factor = Insertion loss + Cable loss
  6. Emission Level = Correction Factor + Reading Value.

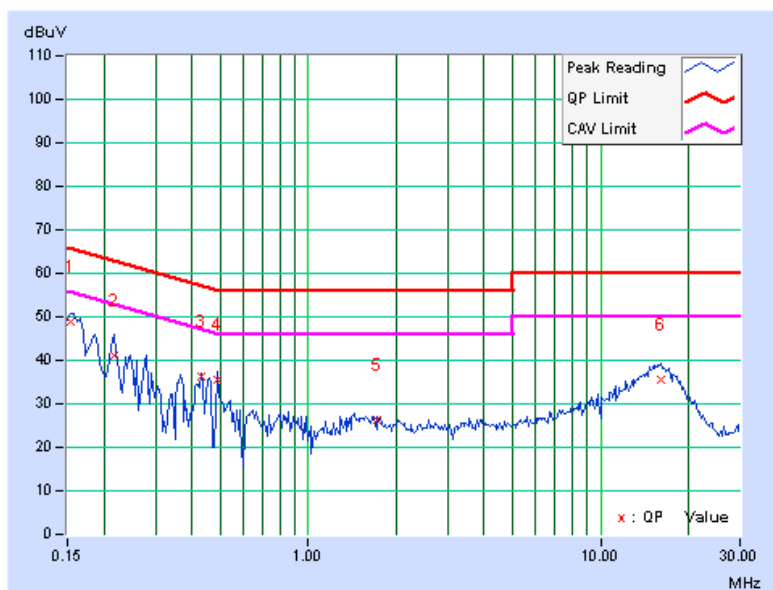





A D T

802.11a (Frequency: 5500-5700MHz)

PHASE	Line 1	6dB BANDWIDTH	9kHz
-------	--------	---------------	------

No	Freq.	Corr.	Reading Value		Emission Level		Limit		Margin	
	[MHz]	Factor (dB)	[dB (uV)]		[dB (uV)]		[dB (uV)]		(dB)	
			Q.P.	AV.	Q.P.	AV.	Q.P.	AV.	Q.P.	AV.
1	0.154	0.16	48.69	-	48.85	-	65.79	55.79	-16.94	-
2	0.184	0.16	42.92	-	43.08	-	64.30	54.30	-21.23	-
3	0.429	0.18	32.49	-	32.67	-	57.28	47.28	-24.61	-
4	0.490	0.19	33.18	-	33.37	-	56.17	46.17	-22.80	-
5	1.379	0.26	25.05	-	25.31	-	56.00	46.00	-30.69	-
6	15.762	0.53	35.39	-	35.92	-	60.00	50.00	-24.08	-

- REMARKS:**
1. Q.P. and AV. are abbreviations of quasi-peak and average individually.
  2. "-": The Quasi-peak reading value also meets average limit and measurement with the average detector is unnecessary.
  3. The emission levels of other frequencies were very low against the limit.
  4. Margin value = Emission level - Limit value
  5. Correction factor = Insertion loss + Cable loss
  6. Emission Level = Correction Factor + Reading Value.

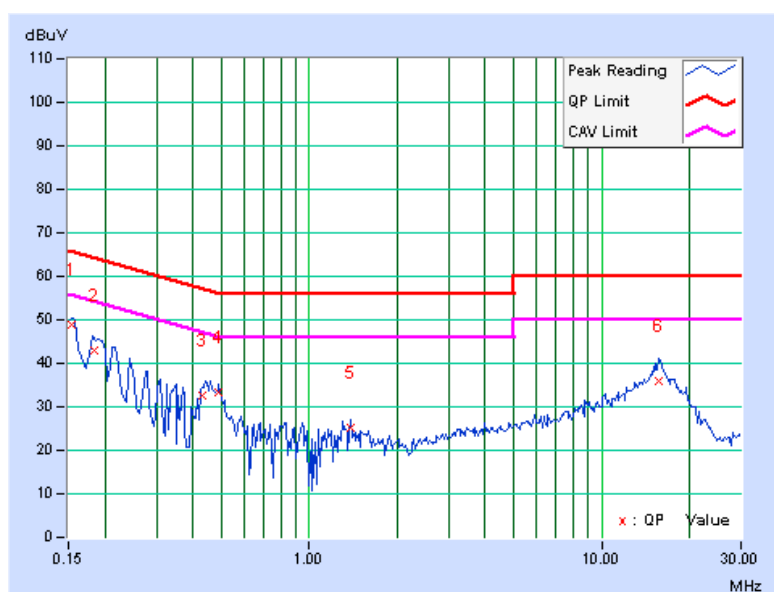

PHASE	Line 2	6dB BANDWIDTH	9kHz
-------	--------	---------------	------

No	Freq. [MHz]	Corr. Factor (dB)	Reading Value		Emission Level		Limit		Margin	
			[dB (uV)]		[dB (uV)]		[dB (uV)]		(dB)	
			Q.P.	AV.	Q.P.	AV.	Q.P.	AV.	Q.P.	AV.
1	0.154	0.13	48.71	-	48.84	-	65.79	55.79	-16.95	-
2	0.185	0.13	42.94	-	43.07	-	64.25	54.25	-21.18	-
3	0.216	0.13	41.00	-	41.13	-	62.96	52.96	-21.82	-
4	0.492	0.17	35.18	-	35.35	-	56.13	46.13	-20.78	-
5	1.351	0.25	25.77	-	26.02	-	56.00	46.00	-29.98	-
6	15.465	0.68	35.18	-	35.86	-	60.00	50.00	-24.14	-

- REMARKS:**
1. Q.P. and AV. are abbreviations of quasi-peak and average individually.
  2. "-": The Quasi-peak reading value also meets average limit and measurement with the average detector is unnecessary.
  3. The emission levels of other frequencies were very low against the limit.
  4. Margin value = Emission level - Limit value
  5. Correction factor = Insertion loss + Cable loss
  6. Emission Level = Correction Factor + Reading Value.

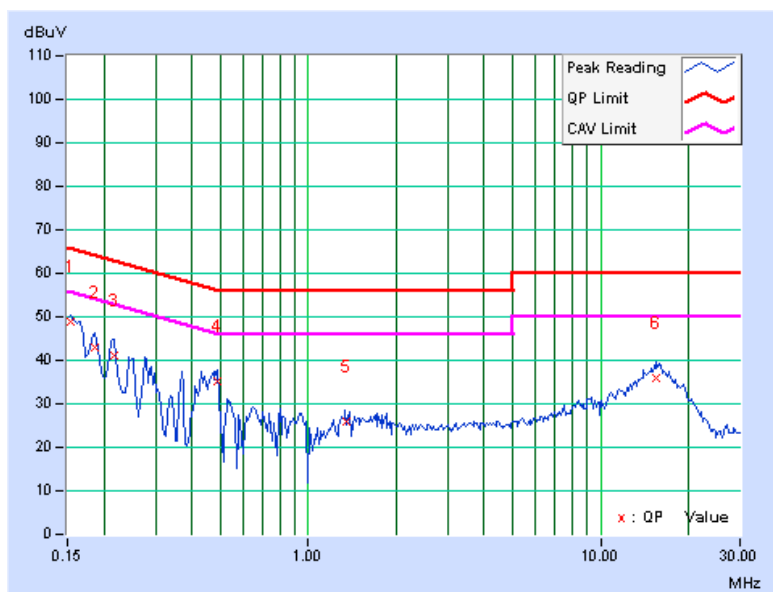



A D T

### 4.3 MAXIMUM CONDUCTED OUTPUT POWER MEASUREMENT

#### 4.3.1 LIMITS OF MAXIMUM CONDUCTED OUTPUT POWER MEASUREMENT

FREQUENCY BAND	LIMIT
5.150 ~ 5.250GHz	The lesser of 50mW (17dBm) or 4dBm + 10logB
5.250 ~ 5.350GHz	The lesser of 250mW (24dBm) or 11dBm + 10logB
5.470 ~ 5.725GHz	The lesser of 250mW (24dBm) or 11dBm + 10logB

**NOTE:** Where B is the 26dB emission bandwidth in MHz.

#### 4.3.2 TEST INSTRUMENTS

##### FOR POWER OUTPUT MEASUREMENT

DESCRIPTION & MANUFACTURER	MODEL NO.	SERIAL NO.	DATE OF CALIBRATION	CALIBRATED UNTIL
High Speed Peak Power Meter	ML2495A	0824012	Aug. 10, 2009	Aug. 09, 2010
Power Sensor	MA2411B	0738138	Aug. 10, 2009	Aug. 09, 2010

**NOTE:**

1. The calibration interval of the above test instruments is 12 months and the calibrations are traceable to NML/ROC and NIST/USA.
2. Measurement Bandwidth of ML2495A is 65MHz greater than 26dB bandwidth of emission.

##### FOR 26dB OCCUPIED BANDWIDTH

DESCRIPTION & MANUFACTURER	MODEL NO.	SERIAL NO.	DATE OF CALIBRATION	DUE DATE OF CALIBRATION
SPECTRUM ANALYZER R&S	FSP40	100040	Jul. 07, 2009	Jul. 06, 2010

**NOTE:** The calibration interval of the above test instruments is 12 months and the calibrations are traceable to NML/ROC and NIST/USA.

### 4.3.3 TEST PROCEDURES

#### FOR POWER OUTPUT MEASUREMENT

A power sensor was used on the output port of the EUT. A power meter was used to read the response of the power sensor. Record the power level.

#### FOR 26dB OCCUPIED BANDWIDTH

The transmitter output was connected to the spectrum analyzer through an attenuator. The bandwidth of the fundamental frequency was measured by spectrum analyzer with 300kHz RBW and 1MHz VBW. The 26dB bandwidth is defined as the total spectrum the power of which is higher than peak power minus 26dB.

### 4.3.4 DEVIATION FROM TEST STANDARD

No deviation.

### 4.3.5 TEST SETUP

#### FOR POWER OUTPUT MEASUREMENT

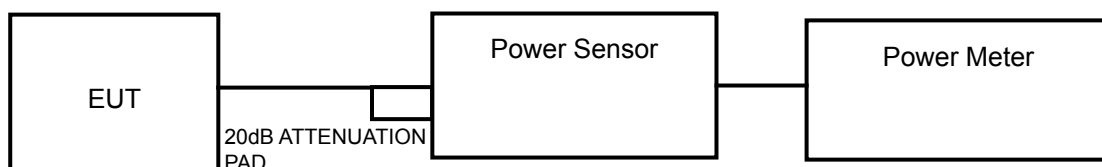

#### FOR 26dB OCCUPIED BANDWIDTH

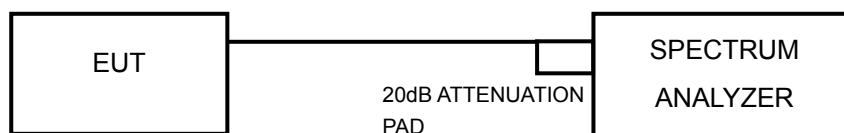

### 4.3.6 EUT OPERATING CONDITIONS

The software provided by client to enable the EUT under transmission condition continuously at specific channel frequencies individually.



A D T

### 4.3.7 TEST RESULTS

#### POWER OUTPUT: 802.11a

CHANNEL	CHANNEL FREQUENCY (MHz)	OUTPUT POWER (mW)	OUTPUT POWER (dBm)	POWER LIMIT (dBm)	PASS / FAIL
36	5180	6.2	7.9	17	PASS
40	5200	6.3	8.0	17	PASS
48	5240	6.2	7.9	17	PASS
52	5260	6.0	7.8	24	PASS
60	5300	6.2	7.9	24	PASS
64	5320	6.3	8.0	24	PASS
100	5500	7.9	9.0	24	PASS
116	5580	7.9	9.0	24	PASS
132	5660	9.8	9.9	24	PASS
140	5700	7.9	9.0	24	PASS



A D T

### 26dB OCCUPIED BANDWIDTH: 802.11a

CHANNEL	CHANNEL FREQUENCY (MHz)	26dBc OCCUPIED BANDWIDTH (MHz)	PASS / FAIL
36	5180	20.85	PASS
40	5200	20.90	PASS
48	5240	20.98	PASS
52	5260	20.88	PASS
60	5300	20.82	PASS
64	5320	21.49	PASS
100	5500	21.19	PASS
116	5580	20.94	PASS
132	5660	20.86	PASS
140	5700	20.89	PASS

### CH 64

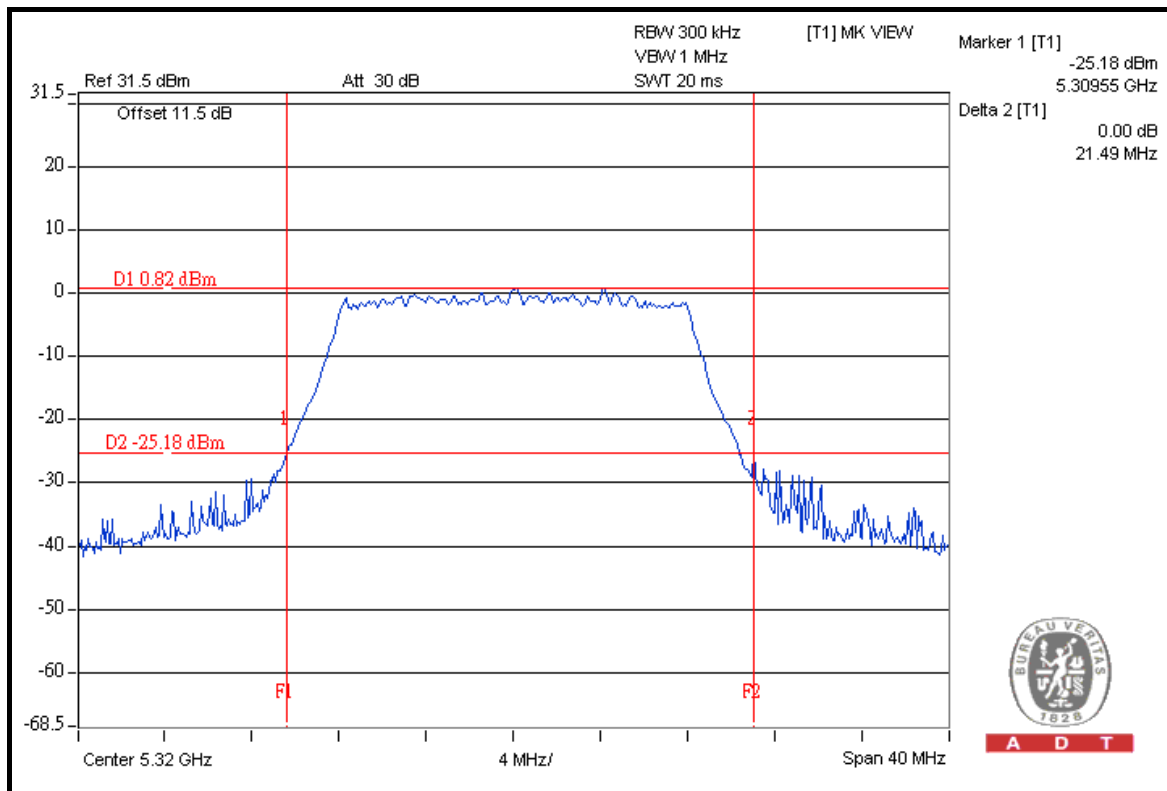

#### 4.4 PEAK POWER EXCURSION MEASUREMENT

##### 4.4.1 LIMITS OF PEAK POWER EXCURSION MEASUREMENT

FREQUENCY BAND	LIMIT
5.150 ~ 5.250GHz	13dB
5.250 ~ 5.350GHz	13dB
5.470 ~ 5.725GHz	13dB

##### 4.4.2 TEST INSTRUMENTS

DESCRIPTION & MANUFACTURER	MODEL NO.	SERIAL NO.	DATE OF CALIBRATION	DUE DATE OF CALIBRATION
SPECTRUM ANALYZER R&S	FSP40	100040	Jul. 07, 2009	Jul. 06, 2010

**NOTE:** The calibration interval of the above test instruments is 12 months and the calibrations are traceable to NML/ROC and NIST/USA.

##### 4.4.3 TEST PROCEDURE

- a. The transmitter output was connected to the spectrum analyzer.
- b. Set the spectrum bandwidth span to view the entire spectrum.
- c. Using peak detector and Max-hold function for Trace 1 (RB = 1MHz, VB = 3MHz) and 2 (RB = 1MHz, VB = 300 kHz).
- d. The differences between Trace1 and Trace 2 in any 1MHz band at f1 to f2 range were recorded and showed to another trace.

#### 4.4.4 DEVIATION FROM TEST STANDARD

No deviation.

#### 4.4.5 TEST SETUP

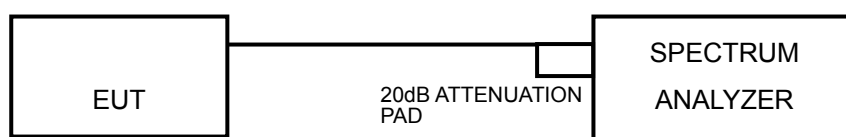

#### 4.4.6 EUT OPERATING CONDITIONS

The software provided by client to enable the EUT under transmission condition continuously at specific channel frequencies individually.





A D T

#### 4.4.7 TEST RESULTS

##### 802.11a

CHANNEL	CHANNEL FREQUENCY (MHz)	PEAK POWER EXCURSION (dB)	PEAK TO AVERAGE EXCURSION LIMIT (dB)	PASS/FAIL
36	5180	7.13	13	PASS
40	5200	7.60	13	PASS
48	5240	7.23	13	PASS
52	5260	7.37	13	PASS
60	5300	7.66	13	PASS
64	5320	7.71	13	PASS
100	5500	7.86	13	PASS
116	5580	7.80	13	PASS
132	5660	7.37	13	PASS
140	5700	7.67	13	PASS



A D T

### CH 100

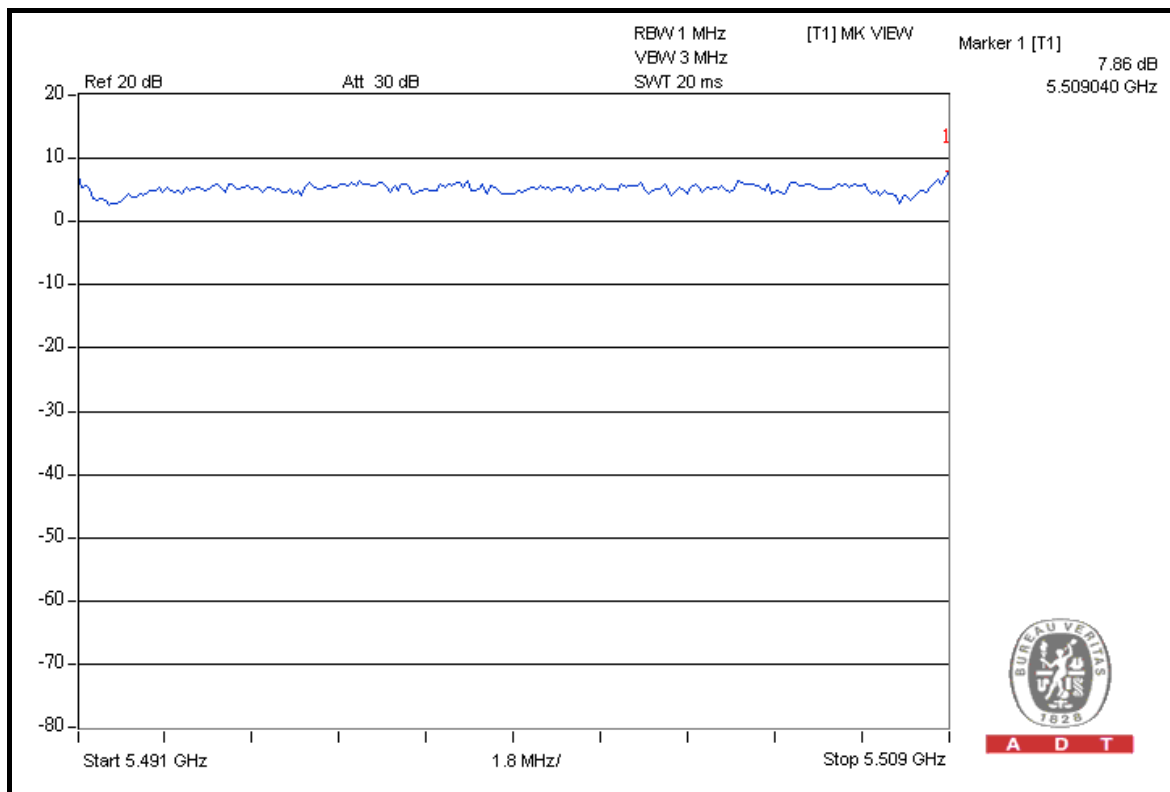
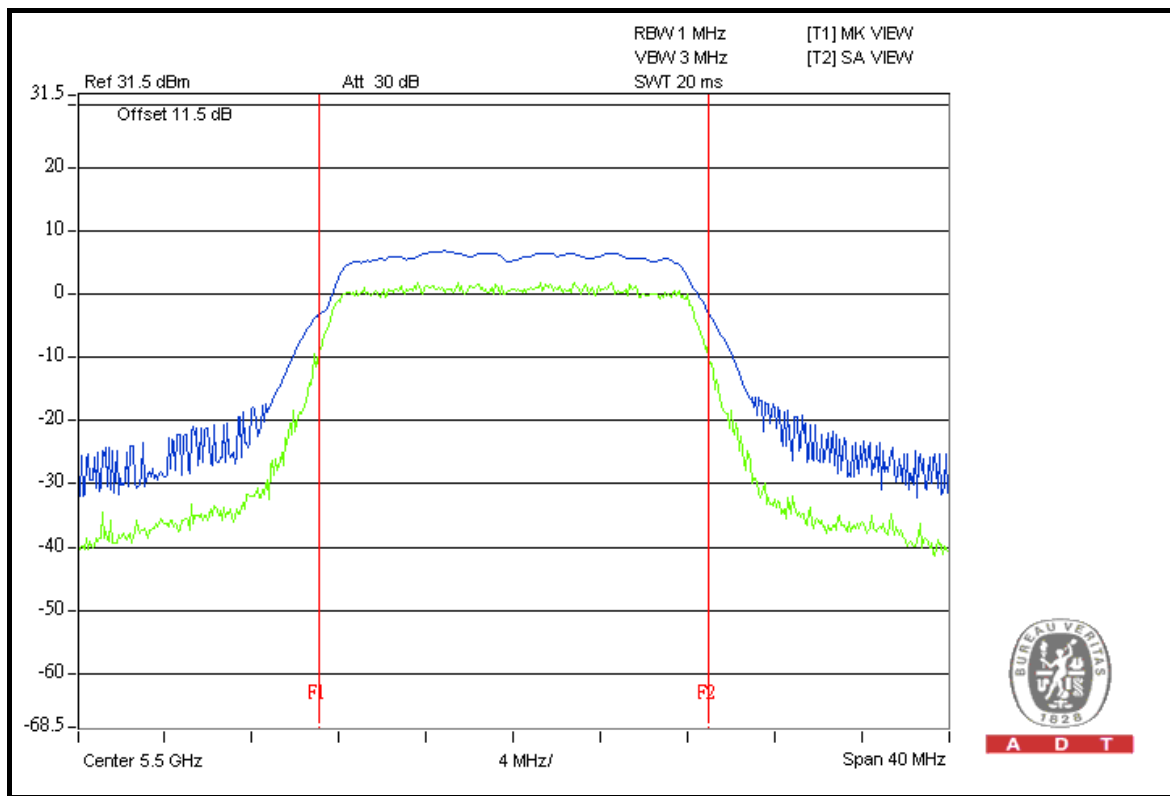

## 4.5 PEAK POWER SPECTRAL DENSITY MEASUREMENT

### 4.5.1 LIMITS OF PEAK POWER SPECTRAL DENSITY MEASUREMENT

FREQUENCY BAND	LIMIT
5.150 ~ 5.250GHz	4dBm
5.250 ~ 5.350GHz	11dBm
5.470 ~ 5.725GHz	11dBm

### 4.5.2 TEST INSTRUMENTS

DESCRIPTION & MANUFACTURER	MODEL NO.	SERIAL NO.	DATE OF CALIBRATION	DUE DATE OF CALIBRATION
SPECTRUM ANALYZER R&S	FSP40	100040	Jul. 07, 2009	Jul. 06, 2010

**NOTE:** The calibration interval of the above test instruments is 12 months and the calibrations are traceable to NML/ROC and NIST/USA.

### 4.5.3 TEST PROCEDURES

- a. The transmitter output was connected to the spectrum analyzer.
- b. Set RBW = 1MHz, VBW = 3MHz. The PPSD is the highest level found across the emission in any 1MHz band.

#### 4.5.4 DEVIATION FROM TEST STANDARD

No deviation.

#### 4.5.5 TEST SETUP



#### 4.5.6 EUT OPERATING CONDITIONS

Same as 5.3.6.



A D T

### 4.5.7 TEST RESULTS

#### 802.11a

CHANNEL	CHANNEL FREQUENCY (MHz )	RF POWER LEVEL IN 1MHz BW (dBm)	MAXIMUM LIMIT (dBm)	PASS / FAIL
36	5180	-4.2	4	PASS
40	5200	-4.2	4	PASS
48	5240	-4.4	4	PASS
52	5260	-4.2	11	PASS
60	5300	-4.1	11	PASS
64	5320	-3.9	11	PASS
100	5500	-3.3	11	PASS
116	5580	-3.0	11	PASS
132	5660	-2.0	11	PASS
140	5700	-2.9	11	PASS

#### CH 132

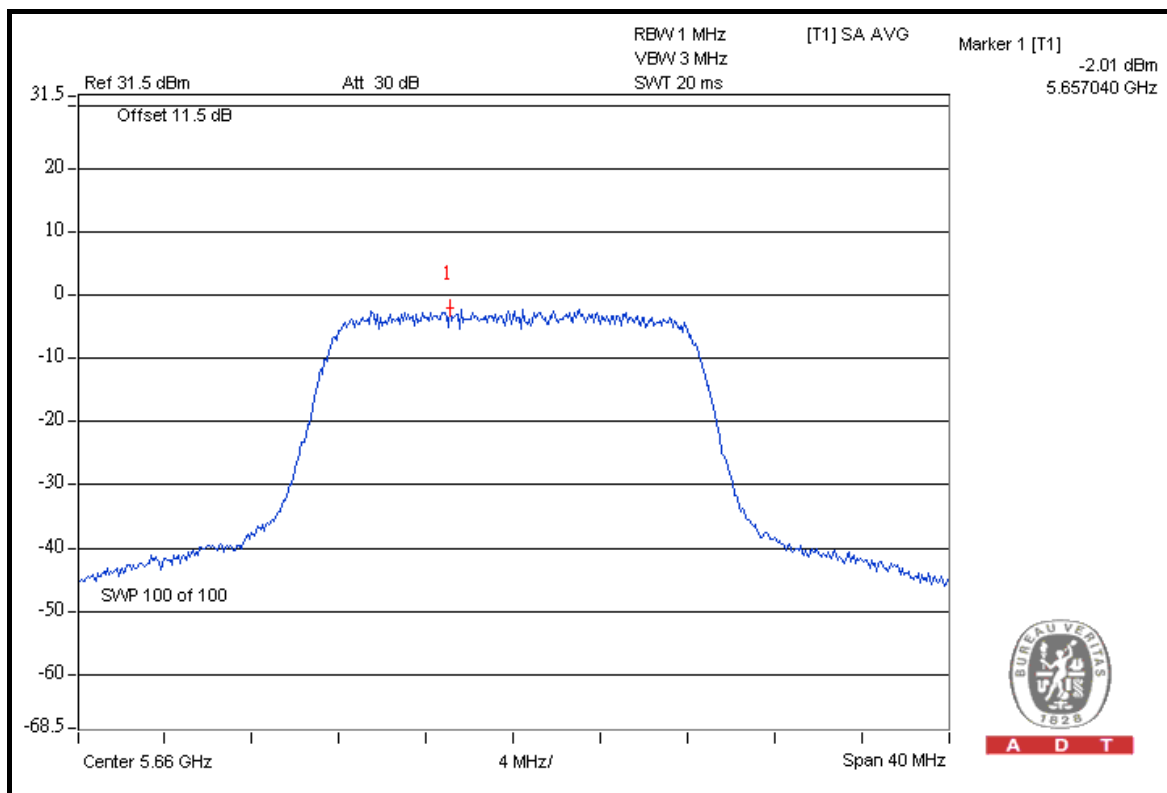

A D T

## 4.6 FREQUENCY STABILITY

### 4.6.1 LIMITS OF FREQUENCY STABILITY MEASUREMENT

The frequency tolerance of the carrier signal shall be maintained within the band of operation frequency over a temperature variation of –30 degrees to 50 degrees C at normal supply voltage, and for a variation in the primary supply voltage from 85% to 115% of the rated supply voltage at a temperature of 20 degrees C.

### 4.6.2 TEST INSTRUMENTS

DESCRIPTION & MANUFACTURER	MODEL NO.	SERIAL NO.	DATE OF CALIBRATION	CALIBRATED UNTIL
SPECTRUM ANALYZER R&S	FSP40	100040	Jul. 07, 2009	Jul. 06, 2010
WIT STANDARD TEMPERATURE AND HUMIDITY CHAMBER	TH-4S-C	W981030	Jun. 24, 2009	Jun. 23, 2010

**NOTE:** The calibration interval of the above test instruments is 12 months and the calibrations are traceable to NML/ROC and NIST/USA.

### 4.6.3 TEST PROCEDURE

- a. The EUT was placed inside the environmental test chamber and powered by nominal DC voltage.
- b. Turn the EUT on and couple its output to a spectrum analyzer.
- c. Turn the EUT off and set the chamber to the highest temperature specified.
- d. Allow sufficient time (approximately 30 min) for the temperature of the chamber to stabilize, turn the EUT on and measure the operating frequency after 2, 5, and 10 minutes.
- e. Repeat step 2 and 3 with the temperature chamber set to the lowest temperature.
- f. The test chamber was allowed to stabilize at +20 degree C for a minimum of 30 minutes. The supply voltage was then adjusted on the EUT from 85% to 115% and the frequency record.

#### 4.6.4 DEVIATION FROM TEST STANDARD

No deviation.

#### 4.6.5 TEST SETUP

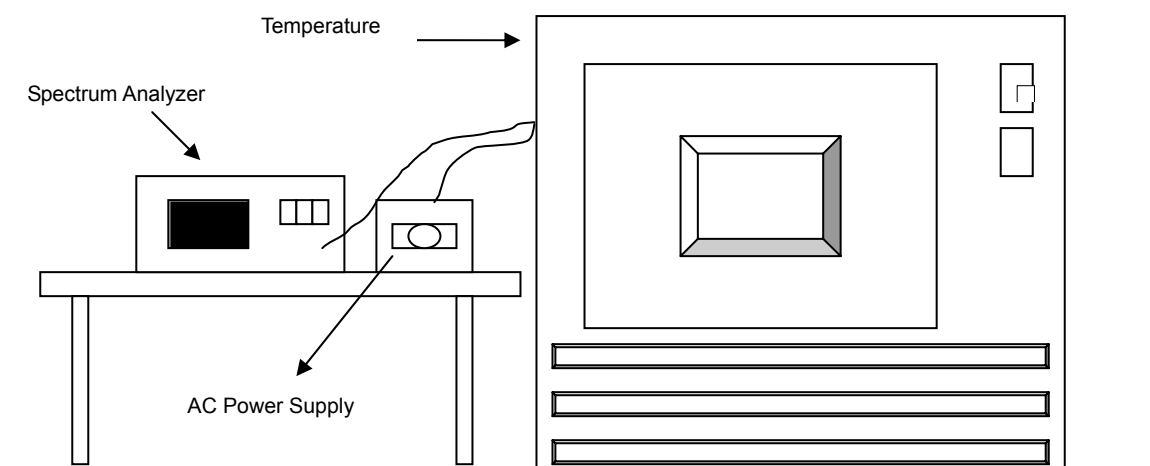

#### 4.6.6 EUT OPERATING CONDITION

Same as Item 4.1.7.



A D T

### 4.6.7 TEST RESULTS

FREQUENCY STABILITY VERSUS TEMP.									
OPERATING FREQUENCY: 5320MHz									
TEMP. (°C)	POWER SUPPLY (Vdc)	0 MINUTE		2 MINUTE		5 MINUTE		10 MINUTE	
		Measured Frequency	Frequency Drift	Measured Frequency	Frequency Drift	Measured Frequency	Frequency Drift	Measured Frequency	Frequency Drift
		(MHz)	ppm	(MHz)	ppm	(MHz)	ppm	(MHz)	ppm
55	3.7	5319.997786	-0.416	5319.997617	-0.448	5319.997339	-0.500	5319.997718	-0.429
50	3.7	5319.998036	-0.369	5319.998492	-0.283	5319.998260	-0.327	5319.998120	-0.353
40	3.7	5319.997835	-0.407	5319.997928	-0.389	5319.997577	-0.455	5319.997402	-0.488
30	3.7	5319.997384	-0.492	5319.997295	-0.508	5319.997007	-0.563	5319.997236	-0.520
20	3.7	5319.996871	-0.588	5319.997280	-0.511	5319.996858	-0.591	5319.997226	-0.521
10	3.7	5319.997113	-0.543	5319.997443	-0.481	5319.997365	-0.495	5319.997417	-0.486
0	3.7	5319.996735	-0.614	5319.996906	-0.582	5319.996854	-0.591	5319.996679	-0.624
-10	3.7	5319.997081	-0.549	5319.997330	-0.502	5319.997194	-0.527	5319.997422	-0.485
-20	3.7	5319.997438	-0.482	5319.997407	-0.487	5319.997680	-0.436	5319.997864	-0.402
-30	3.7	5319.997809	-0.412	5319.997653	-0.441	5319.997868	-0.401	5319.997946	-0.386

FREQUENCY STABILITY VERSUS VOLTAGE									
OPERATING FREQUENCY: 5320MHz									
TEMP. (°C)	POWER SUPPLY (Vac)	0 MINUTE		2 MINUTE		5 MINUTE		10 MINUTE	
		Measured Frequency	Frequency Drift	Measured Frequency	Frequency Drift	Measured Frequency	Frequency Drift	Measured Frequency	Frequency Drift
		(MHz)	ppm	(MHz)	ppm	(MHz)	ppm	(MHz)	ppm
20	3.300	5319.997542	-0.462	5319.997069	-0.551	5319.997508	-0.468	5319.997164	-0.533
	3.700	5319.996871	-0.588	5319.997280	-0.511	5319.996858	-0.591	5319.997226	-0.521
	4.255	5319.996507	-0.657	5319.996559	-0.647	5319.996311	-0.693	5319.996132	-0.727



## 4.7 BAND EDGES MEASUREMENT

### 4.7.1 TEST INSTRUMENTS

DESCRIPTION & MANUFACTURER	MODEL NO.	SERIAL NO.	DATE OF CALIBRATION	DUE DATE OF CALIBRATION
SPECTRUM ANALYZER R&S	FSP40	100040	Jul. 07, 2009	Jul. 06, 2010

**NOTE:** The calibration interval of the above test instruments is 12 months and the calibrations are traceable to NML/ROC and NIST/USA.

### 4.7.2 TEST PROCEDURE

The transmitter output was connected to the spectrum analyzer via a low lose cable. Set both RBW and VBW of spectrum analyzer to 1MHz and 3MHz with suitable frequency span including 100MHz bandwidth from band edge. The band edges was measured and recorded.

### 4.7.3 EUT OPERATING CONDITION

The software provided by client to enable the EUT under transmission condition continuously at specific channel frequencies individually.

### 4.7.4 TEST RESULTS

For signals in the restricted bands above and below the 5.18 to 5.32GHz and 5.50 to 5.70GHz allocated band a measurement was made of the amplitude of the spurious emissions with respect to the intentional signals. The relative amplitude, in dBc, was applied to the average and peak filed strength of the intentional signal made on the OATS to calculate the field strength of the unintentional signals.

The spectrum plots (Peak RBW = 1MHz, VBW = 3MHz) are attached on the following pages.

**FOR 5180-5320MHz BAND: 802.11a**

**RESTRICT BAND (4500 ~ 5150 MHz)**

FREQUENCY (MHz)	FUNDAMENTAL EMISSION (dBuV/m)	DELTA (dB)	MAXIMUM FIELD STRENGTH IN RESTRICT BAND (dBuV/m)	LIMIT (dBuV/m)
5180.00 (PK)	100.40	40.37	60.03	74.00
5180.00 (AV)	90.10	43.16	46.94	54.00

**RESTRICT BAND (5350 ~ 5460 MHz)**

FREQUENCY (MHz)	FUNDAMENTAL EMISSION (dBuV/m)	DELTA (dB)	MAXIMUM FIELD STRENGTH IN RESTRICT BAND (dBuV/m)	LIMIT (dBuV/m)
5320.00 (PK)	102.40	37.66	64.74	74.00
5320.00 (AV)	91.50	43.07	48.43	54.00

**NOTE:**

1. Delta = Amplitude between the peak of the fundamental and the peak of the band edge emission. Please check following 3 pages.
2. Maximum field strength in restrict band = Fundamental emission – Delta.



A D T

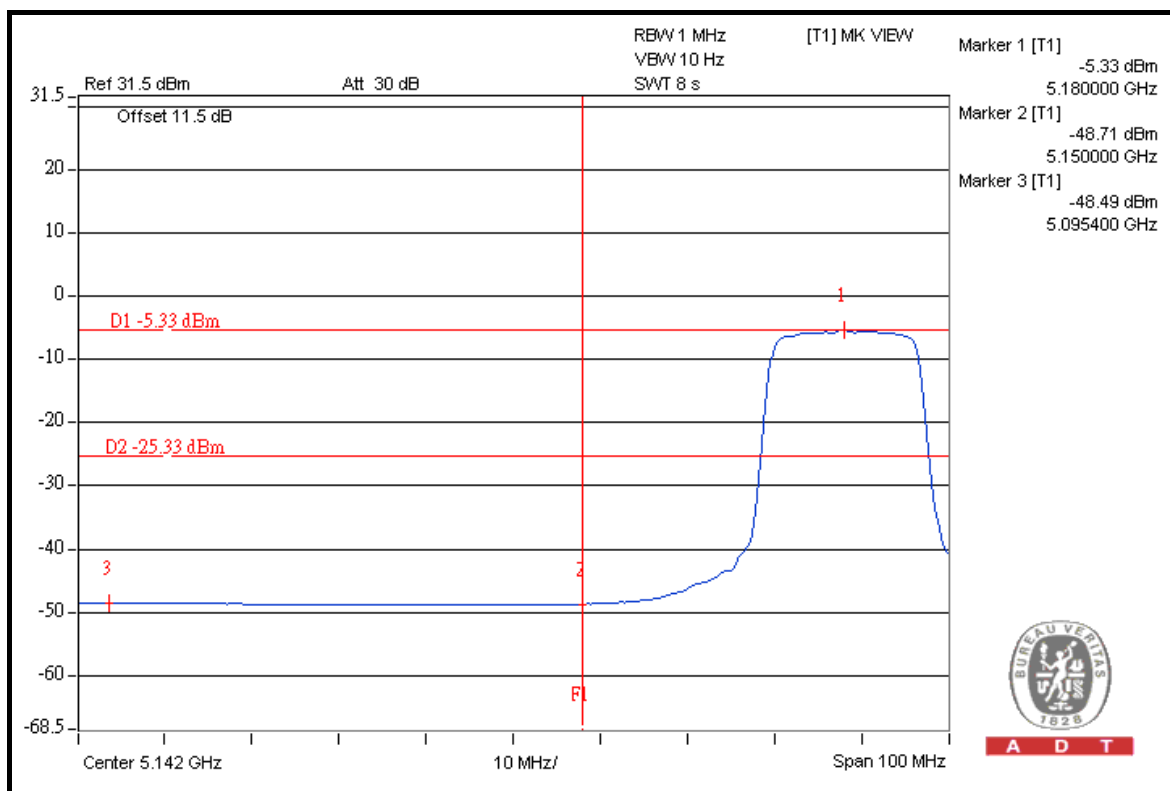
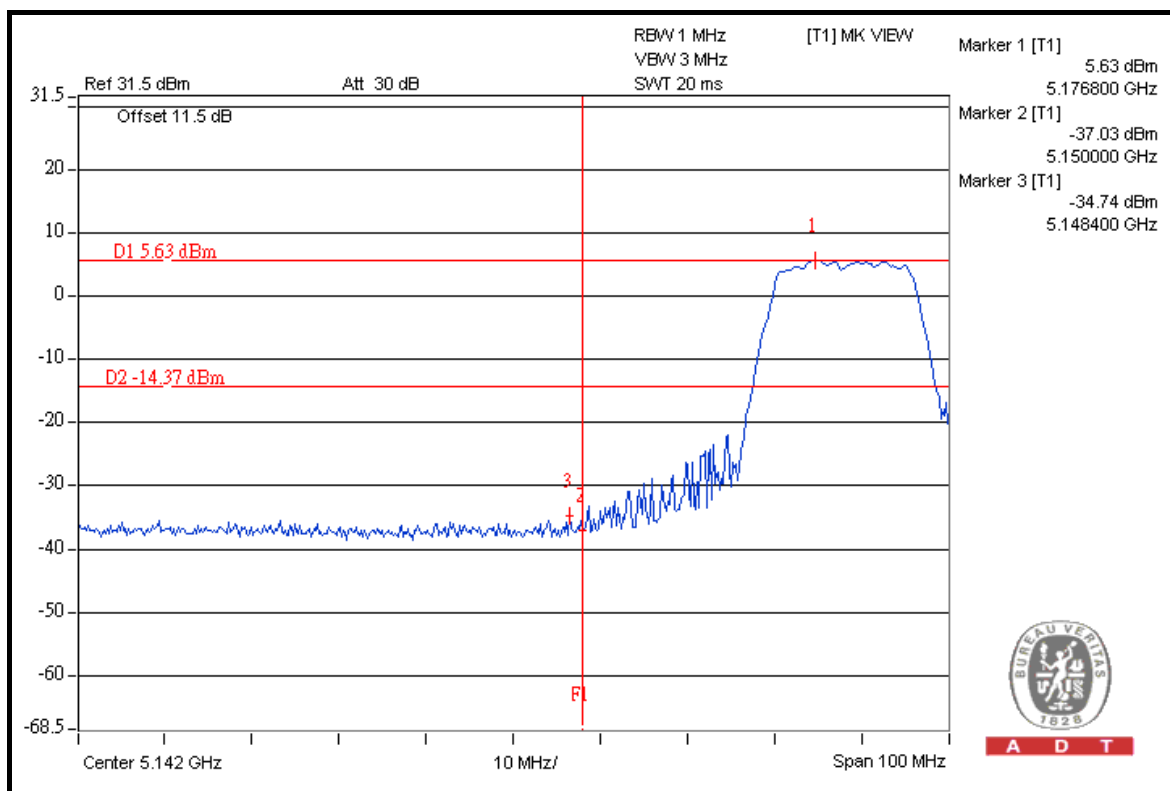



A D T

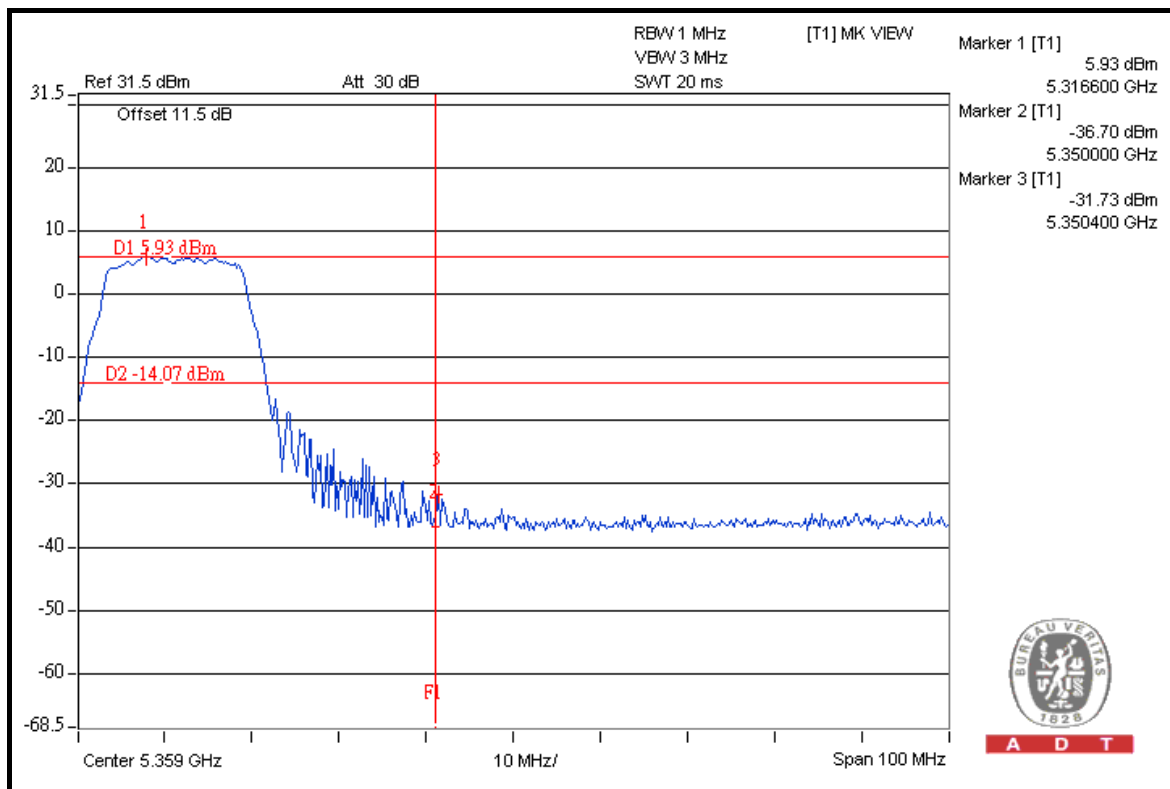
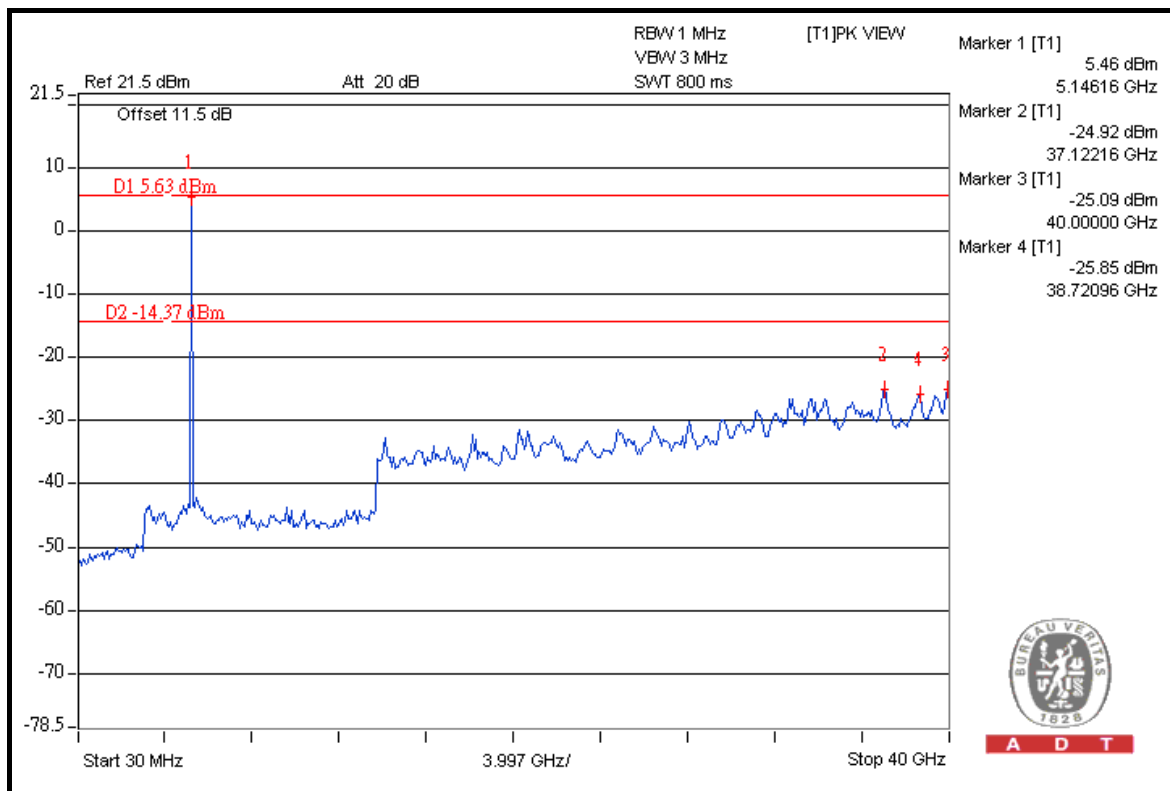



A D T

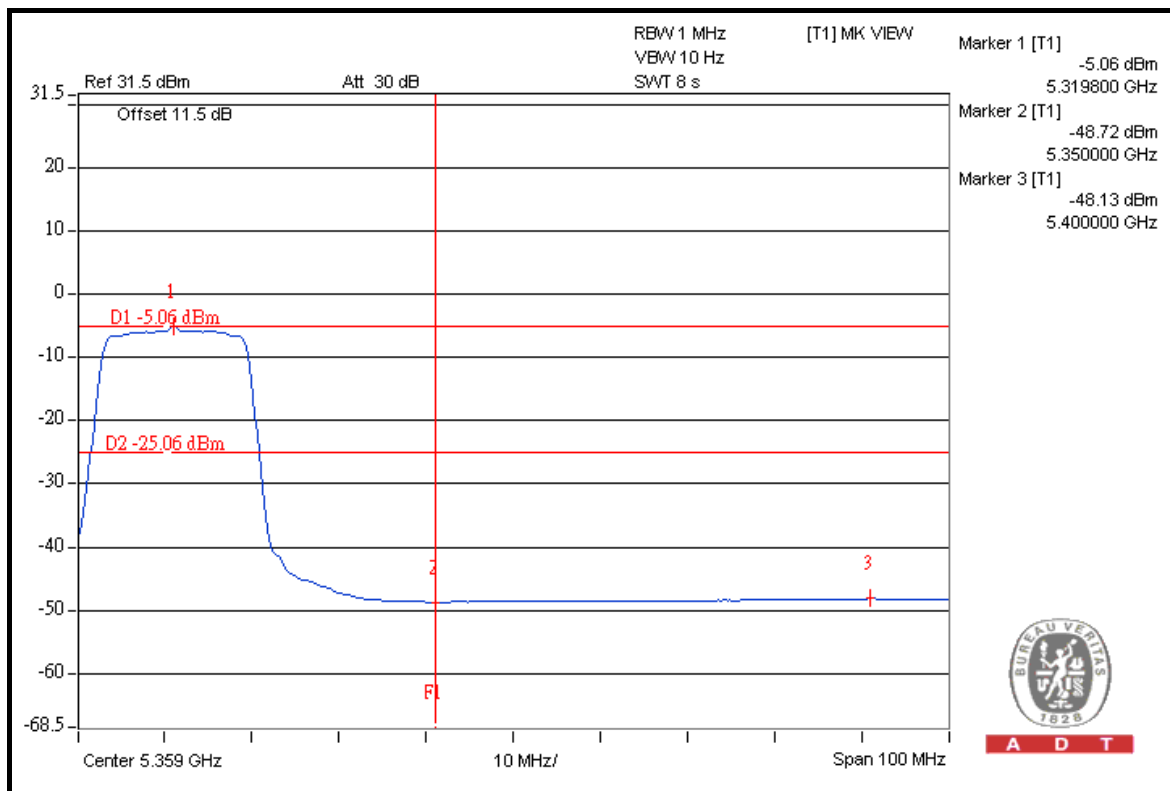

A D T

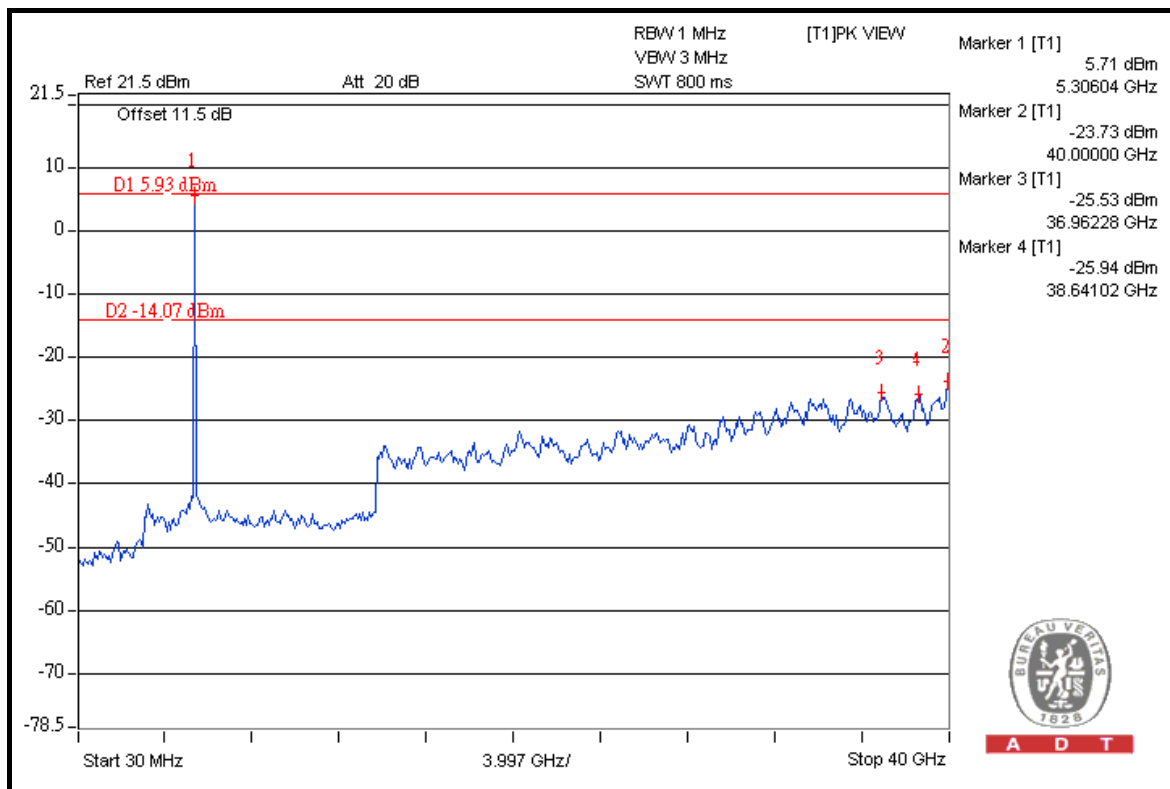

A D T

**FOR 5500-5700MHz BAND: 802.11a**

**5500MHz**

**RESTRICT BAND (5350 ~ 5460 MHz)**

FREQUENCY (MHz)	FUNDAMENTAL EMISSION (dBuV/m)	DELTA (dB)	MAXIMUM FIELD STRENGTH IN RESTRICT BAND (dBuV/m)	LIMIT (dBuV/m)
5500.00 (PK)	101.70	41.39	60.31	74.00
5500.00 (AV)	91.50	43.02	48.48	54.00

**FREQUENCY BAND (5460 ~ 5470 MHz)**

FREQUENCY (MHz)	FUNDAMENTAL EMISSION (dBuV/m)	DELTA (dB)	MAXIMUM FIELD STRENGTH (dBuV/m)	LIMIT (dBuV/m)
5500.00 (PK)	101.70	38.05	63.65	68.30

**5700MHz**

**ABOVE 5725 MHz**

FREQUENCY (MHz)	FUNDAMENTAL EMISSION (dBuV/m)	DELTA (dB)	MAXIMUM FIELD STRENGTH (dBuV/m)	LIMIT (dBuV/m)
5700.00 (PK)	100.10	36.23	63.87	68.30

**NOTE:**

- Delta = Amplitude between the peak of the fundamental and the peak of the band edge emission. Please check following 3 pages.
- Maximum field strength in restrict band = Fundamental emission – Delta.



A D T

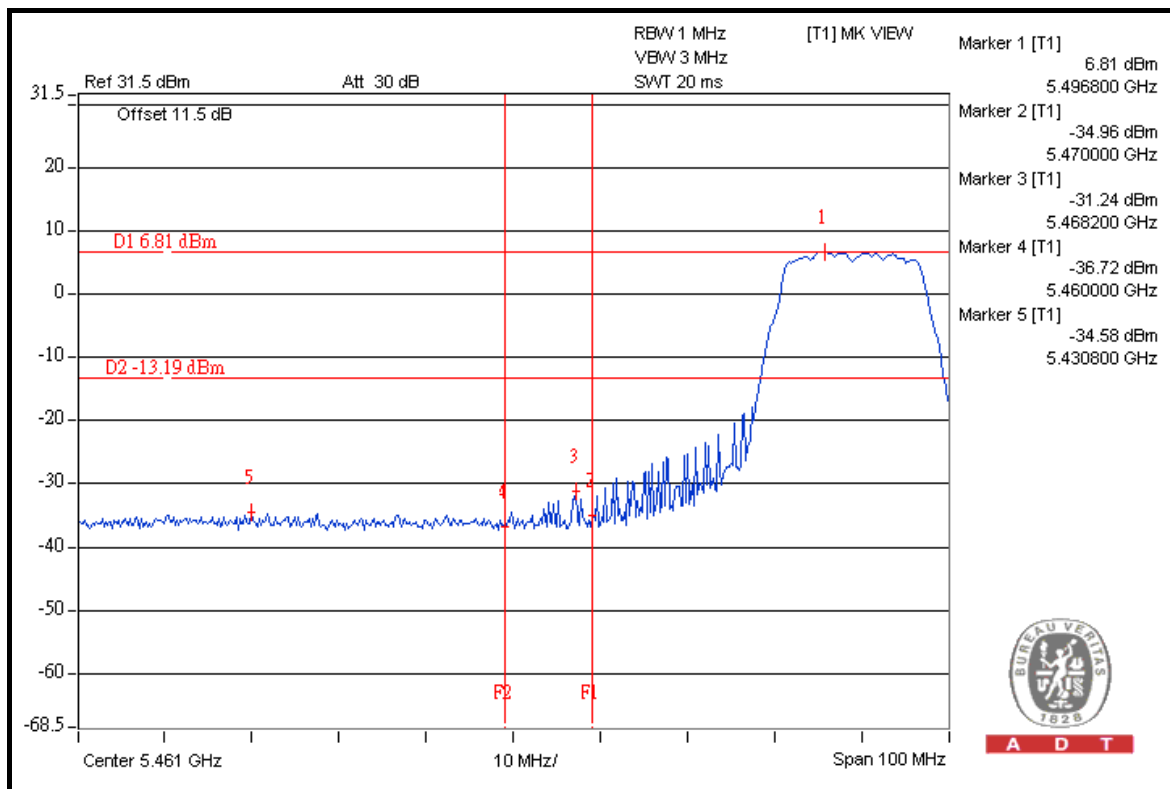

A D T

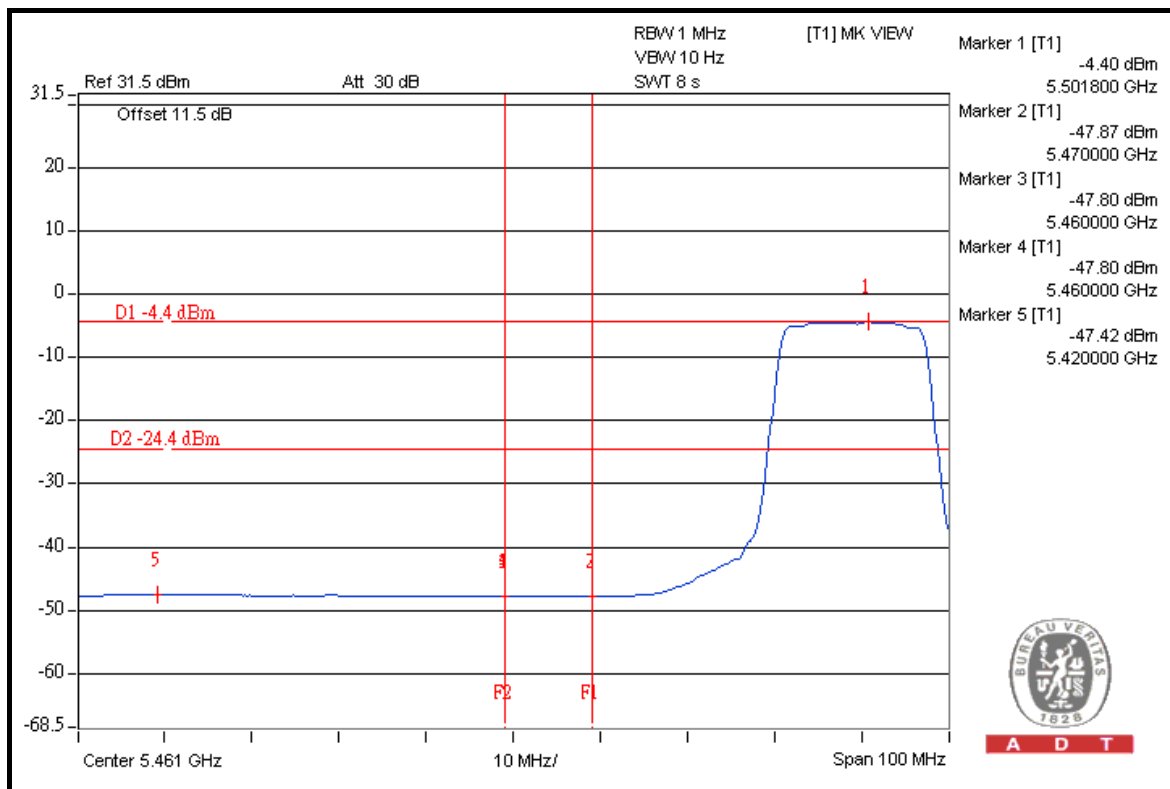

A D T



A D T

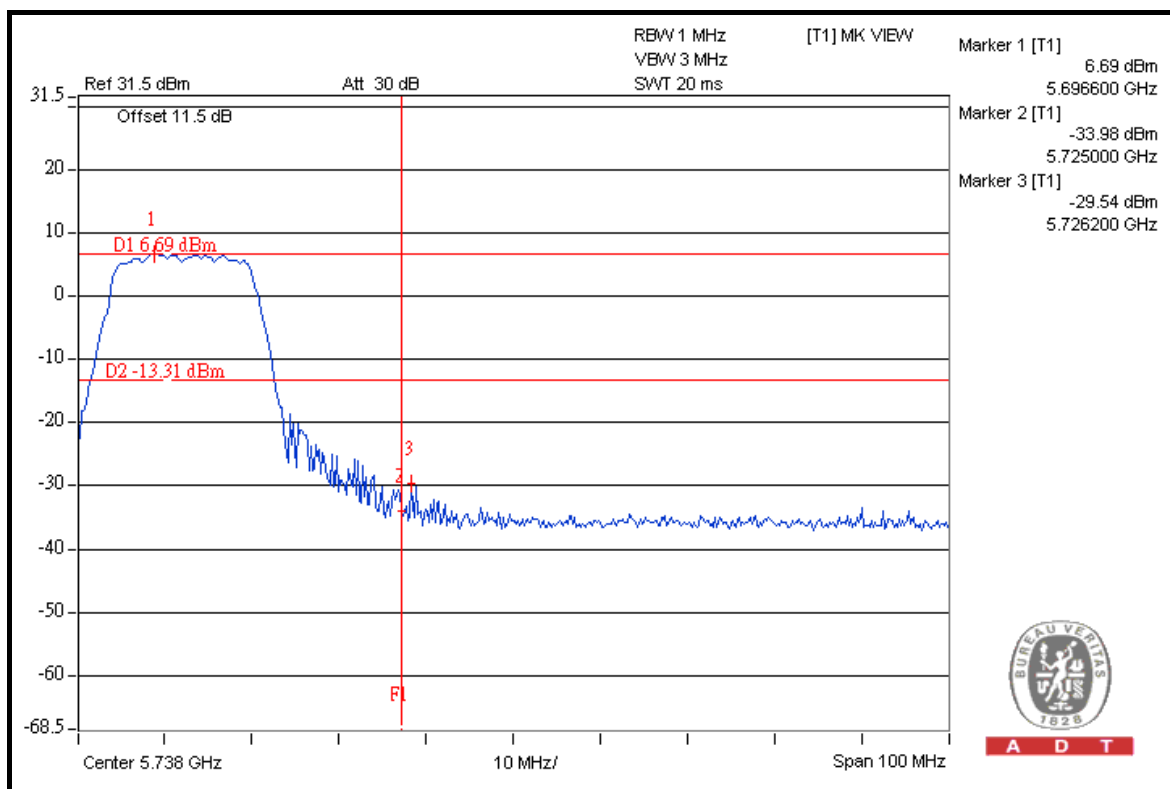
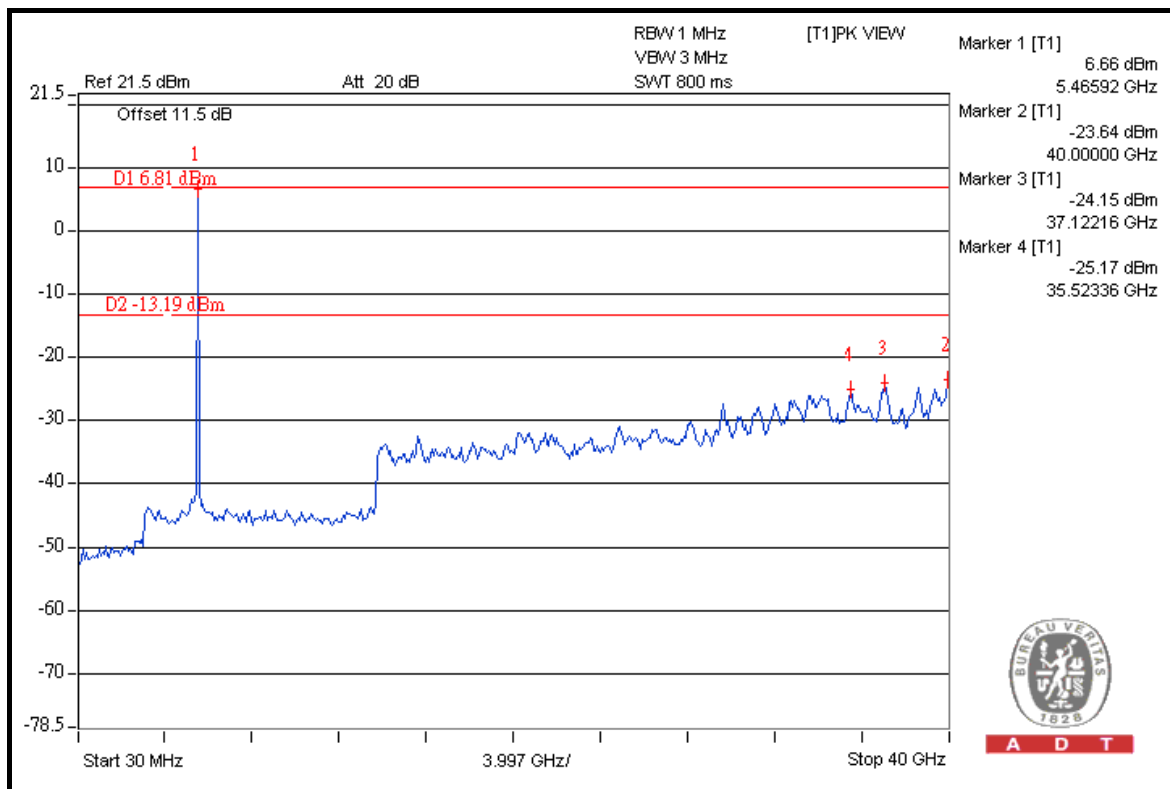





A D T

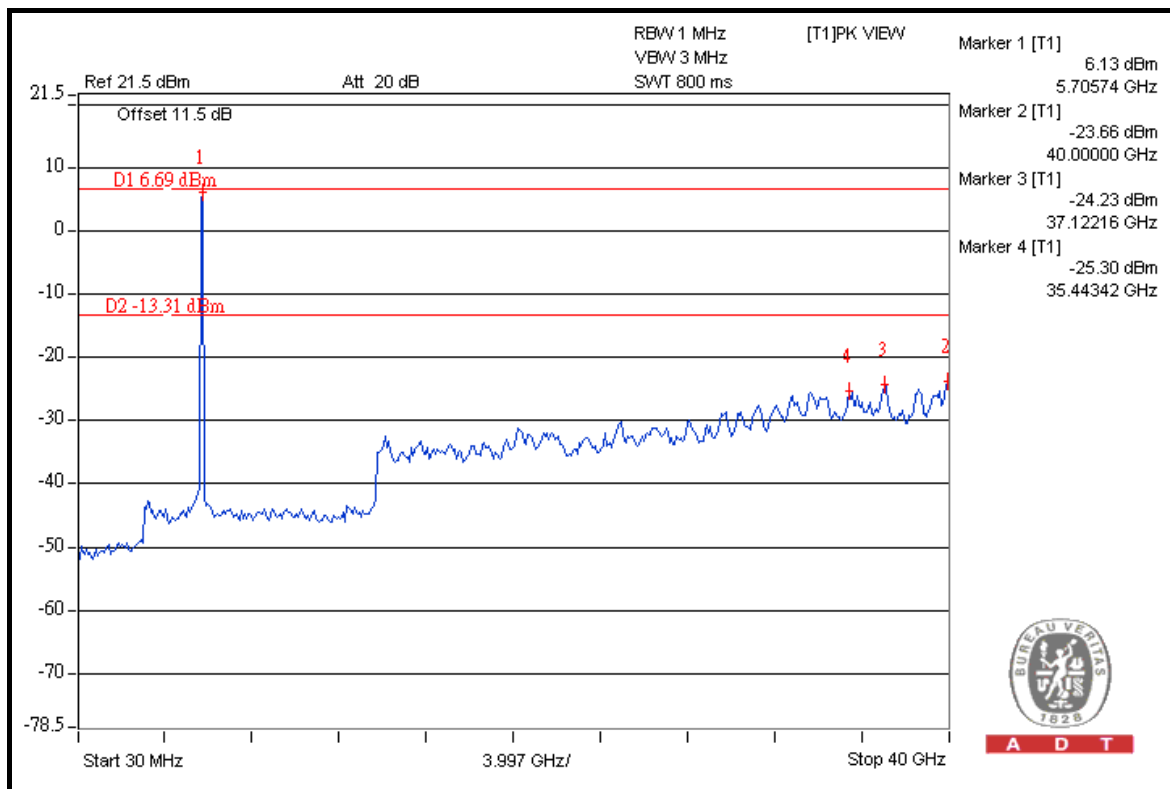
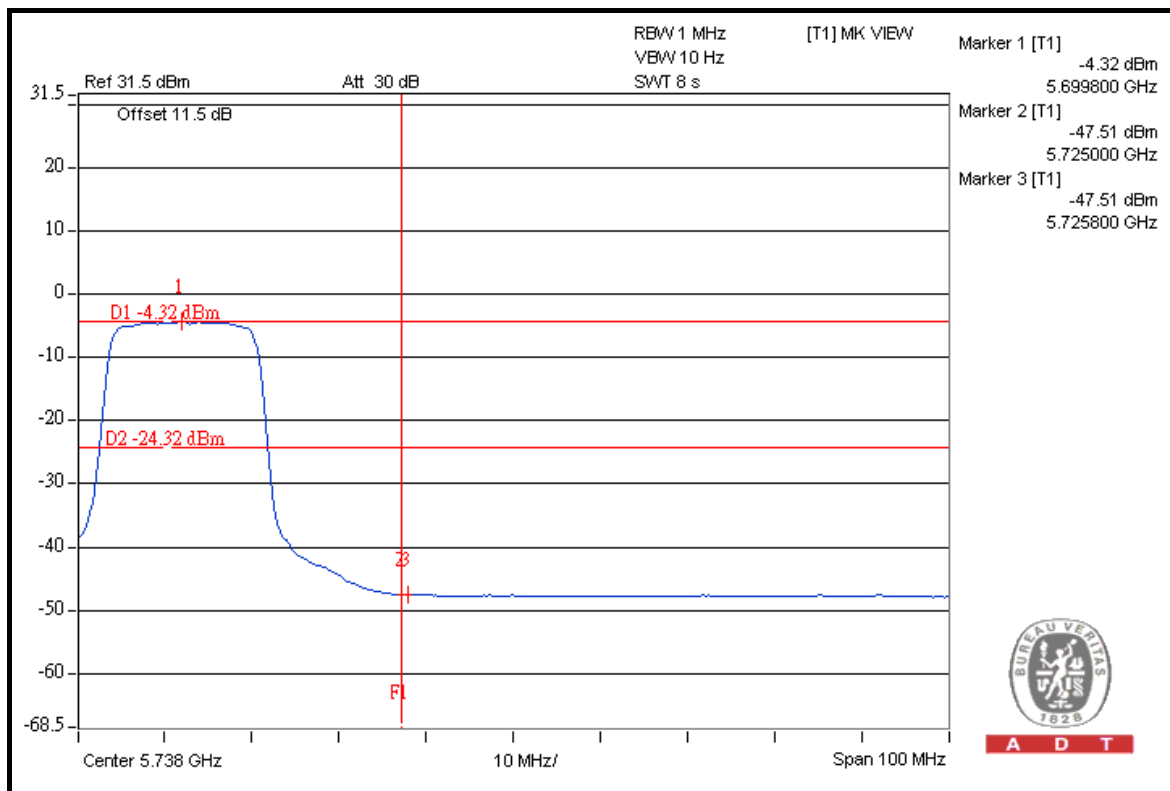



## 5. PHOTOGRAPHS OF THE TEST CONFIGURATION

Please refer to the attached file (Test Setup Photo).



## 6. INFORMATION ON THE TESTING LABORATORIES

We, Bureau Veritas Consumer Products Services (H.K.) Ltd., Taoyuan Branch, were founded in 1988 to provide our best service in EMC, Radio, Telecom and Safety consultation. Our laboratories are accredited and approved according to ISO/IEC 17025.

Copies of accreditation certificates of our laboratories obtained from approval agencies can be downloaded from our web site:

[www.adt.com.tw/index.5/phtml](http://www.adt.com.tw/index.5/phtml). If you have any comments, please feel free to contact us at the following:

**Linko EMC/RF Lab:**

Tel: 886-2-26052180

Fax: 886-2-26051924

**Hsin Chu EMC/RF Lab:**

Tel: 886-3-5935343

Fax: 886-3-5935342

**Hwa Ya EMC/RF/Safety Telecom Lab:**

Tel: 886-3-3183232

Fax: 886-3-3185050

**Web Site:** [www.adt.com.tw](http://www.adt.com.tw)

The address and road map of all our labs can be found in our web site also.

## **7. APPENDIX A - MODIFICATIONS RECORDERS FOR ENGINEERING CHANGES TO THE EUT BY THE LAB**

No any modifications are made to the EUT by the lab during the test.

**---END---**