



SAR TEST REPORT (15.407)

REPORT NO.: SA981105L04-1

MODEL NO.: MC75A6

RECEIVED: Nov. 06, 2009

TESTED: Apr. 16 ~ Apr. 20, 2010

ISSUED: Jun. 14, 2010

APPLICANT: Symbol Technologies, Inc.

ADDRESS: One Motorola Plaza, Holtsville, NY-11742-1300,
U.S.A.

ISSUED BY: Bureau Veritas Consumer Products Services
(H.K.) Ltd., Taoyuan Branch

LAB ADDRESS: No. 47, 14th Ling, Chia Pau Tsuen, Lin Kou
Hsiang, Taipei Hsien 244, Taiwan, R.O.C.

TEST LOCATION: No. 19, Hwa Ya 2nd Rd, Wen Hwa Tsuen, Kwei
Shan Hsiang, Taoyuan Hsien 333, Taiwan, R.O.C.

This test report consists of 32 pages in total except Appendix. It may be duplicated completely for legal use with the approval of the applicant. It should not be reproduced except in full, without the written approval of our laboratory. The client should not use it to claim product endorsement by TAF or any government agencies. The test results in the report only apply to the tested sample.





TABLE OF CONTENTS

- 1. CERTIFICATION 3
- 2. GENERAL INFORMATION 4
 - 2.1 GENERAL DESCRIPTION OF EUT..... 4
 - 2.2 GENERAL DESCRIPTION OF APPLIED STANDARDS..... 6
 - 2.3 GENERAL INFORMATION OF THE SAR SYSTEM 6
 - 2.4 TEST EQUIPMENT 10
 - 2.5 GENERAL DESCRIPTION OF THE SPATIAL PEAK SAR EVALUATION 11
- 3. DESCRIPTION OF SUPPORT UNITS 14
 - 4.1. DESCRIPTION OF TEST POSITION..... 15
 - 4.1.1 TOUCH/CHEEK TEST POSITION 16
 - 4.1.2 TILT TEST POSITION 17
 - 4.1.3 BODY-WORN CONFIGURATION 17
- 5. RECIPES FOR TISSUE SIMULATING LIQUIDS 18
- 6. SYSTEM VALIDATION 24
 - 6.1 TEST PROCEDURE 24
 - 6.2 VALIDATION RESULTS 26
 - 6.3 SYSTEM VALIDATION UNCERTAINTIES 27
- 7. TEST RESULTS 28
 - 7.1 TEST PROCEDURES 28
 - 7.2 MEASURED SAR RESULTS 30
 - 7.3 SAR LIMITS 31
- 8. INFORMATION ON THE TESTING LABORATORIES 32

APPENDIX A: TEST CONFIGURATIONS AND TEST DATA

APPENDIX B: ADT SAR MEASUREMENT SYSTEM

APPENDIX C: PHOTOGRAPHS OF SYSTEM VALIDATION

APPENDIX D: SYSTEM CERTIFICATE & CALIBRATION



A D T

1. CERTIFICATION

PRODUCT: EDA (Enterprise Digital Assistant)
MODEL NO.: MC75A6
BRAND: Symbol
APPLICANT: Symbol Technologies, Inc.
TESTED: Apr. 16 ~ Apr. 20, 2010
TEST SAMPLE: ENGINEERING SAMPLE
STANDARDS: **FCC Part 2 (Section 2.1093)**
FCC OET Bulletin 65, Supplement C (01-01)
RSS-102

The above equipment (model: MC75A6) has been tested by **Bureau Veritas Consumer Products Services (H.K.) Ltd., Taoyuan Branch**, and found compliance with the requirement of the above standards. The test record, data evaluation & Equipment Under Test (EUT) configurations represented herein are true and accurate accounts of the measurements of the sample's EMC characteristics under the conditions specified in this report.

PREPARED BY : Pettie Chen , **DATE** : Jun. 14, 2010
Pettie Chen / Specialist

TECHNICAL ACCEPTANCE : Mason Chang , **DATE** : Jun. 14, 2010
Responsible for RF Mason Chang / Engineer

APPROVED BY : Gary Chang , **DATE** : Jun. 14, 2010
Gary Chang / Assistant Manager

REVISED VERSION	REVISED DATE	DESCRIPTION
Ver. 1	Apr. 29, 2010	1. Reduce output power of WLAN. 2. TX diversity function is disabled by software. Only main antenna can transmit.
Ver. 2	Jun. 09, 2010	Modified the general information
Ver. 3	Jun. 14, 2010	Modified the type error
Ver. 4	Jun. 14, 2010	Modified the description about test report



A D T

2. GENERAL INFORMATION

2.1 GENERAL DESCRIPTION OF EUT

EUT	EDA (Enterprise Digital Assistant)	
MODEL NO.	MC75A6	
FCC ID	H9PMC75A6	
POWER SUPPLY	3.7Vdc (Li-ion battery) 5.4Vdc (Adapter)	
MODULATION TYPE	64QAM, 16QAM, QPSK, BPSK	
MODULATION TECHNOLOGY	OFDM	
TRANSFER RATE	54.0/ 48.0/ 36.0/ 24.0/ 18.0/ 12.0/ 9.0/ 6.0Mbps	
OPERATING FREQUENCY	5180 ~ 5320MHz & 5500 ~ 5700MHz	
NUMBER OF CHANNEL	5180 ~ 5320MHz: 8 5500 ~ 5700MHz: 11	
CHANNEL FREQUENCIES UNDER TEST AND ITS CONDUCTED OUTPUT POWER	Main antenna (AV power)	
	7.9dBm / Ch36: 5180MHz	
	8.0dBm / Ch40: 5200MHz	
	7.8dBm / Ch44: 5220MHz	
	7.9dBm / Ch48: 5240MHz	
	7.9dBm / Ch52: 5260MHz	
	7.9dBm / Ch56: 5280MHz	
	7.9dBm / Ch60: 5300MHz	
	8.0dBm / Ch64: 5320MHz	
	9.0dBm / Ch100: 5500MHz	
	8.9dBm / Ch104: 5520MHz	
	8.9dBm / Ch108: 5540MHz	
	8.9dBm / Ch112: 5560MHz	
	9.0dBm / Ch116: 5580MHz	
9.9dBm / Ch120: 5600MHz		
9.9dBm / Ch124: 5620MHz		
9.9dBm / Ch128: 5640MHz		
9.9dBm / Ch132: 5660MHz		
10.0dBm / Ch136: 5680MHz		
9.0dBm / Ch140: 5700MHz		
MAXIMUM SAR (1g)	Head	Body:
	0.6W/kg	0.05W/kg
ANTENNA TYPE	Refer to NOTE 4 as below	
ANTENNA CONNECTOR	Refer to NOTE 4 as below	
DATA CABLE	NA	
I/O PORTS	Refer to user's manual	
ACCESSORY DEVICES	Battery	

**NOTE:**

1. The EUT is an EDA (Enterprise Digital Assistant). The test data are separated into following test reports:

	REFERENCE REPORT
SAR test report-247 2.4G WLAN	SA981105L04
SAR test report-247 5G WLAN	
SAR test report-407 5G WLAN	SA981105L04-1
SAR test report-247 BLUETOOTH	SA981105L04-2
SAR test report-GSM 850 / WCDMA 850	SA981105L04-3
SAR test report-GSM 1900 / WCDMA 1900	
SAR collocated report-WLAN 802.11a + MOBILE	SA981105L04-4
SAR collocated report-simultaneously Voice and data mode	SA981105L04-5
SAR collocated report- simultaneously WLAN 802.11 a + Voice and data mode	SA981105L04-6
SAR supplement report-preliminary and worst case finding supplement data	SA981105L04-7

2. The models identified as below are identical to each other except of the following options:

- Keypad: Numeric / QWERTY
- Barcode reader: 1D laser scanner / BB Imager

BRAND	MODEL	DESCRIPTION
Symbol	MC75A6	HSDPA 1D Numeric
Symbol	MC75A6	HSDPA 1D QWERTY
Symbol	MC75A6	HSDPA BB Numeric
Symbol	MC75A6	HSDPA BB QWERTY

3. The EUT uses the following Li-ion batteries:

BATTERY 1 (1.5X)	
BRAND:	MOTOROLA
PART NUMBER:	82-71364-05 Rev D
RATING:	3.7Vdc, 3600mAh, 13.3Wh

BATTERY 2 (2.5X)	
BRAND:	MOTOROLA
PART NUMBER:	82-71364-06 Rev C
RATING:	3.7Vdc, 4800mAh, 17.7Wh

*The EUT have been pre-tested and found "BB / QWERTY + 1.5X battery" was the worst case configuration for final test.

4. The EUT used two antennas listed as below:

ANTENNA ITEM	ANTENNA TYPE	TX/RX FUNCTION	ANTENNA CONNECTER	ANTENNA GAIN (dBi)	
				2.4GHz	5.0GHz
MAIN ANTENNA	inverted F	TX/RX	IPEX	-4.39	2.05
AUX. ANTENNA	Planar inverted	RX only	IPEX	2.31	3.29



5. The following accessories are for optional units only.

PRODUCT	BRAND	MODEL	DESCRIPTION
RS232 charging cable	Motorola	25-102776-01R	1.2m non-shielded cable with one core
USB charging cable	Motorola	25-102775-01R	1.5m shielded cable with one core
Headset	Motorola	50-11300-050R	VR10 headset 0.8m non-shielded cable with one core
Power Supply Adaptor	Motorola	EADP-16BB A	I/P: 100-240Vac, 50-60Hz, 0.4A O/P: 5.4Vdc, 3A 1.8m non-shielded cable without core
Fabric holster	Motorola	SG-MC7521215-01R	Contain metal
Ridged holster	Motorola	SG-MC7011110-02R	Contain metal

6. The above EUT information was declared by manufacturer and for more detailed features description, please refer to the manufacturer's specifications or user's manual.

2.2 GENERAL DESCRIPTION OF APPLIED STANDARDS

According to the specifications of the manufacturer, this product must comply with the requirements of the following standards:

FCC Part 2 (2.1093)

FCC OET Bulletin 65, Supplement C (01- 01)

RSS-102

IEEE 1528-2003

All test items have been performed and recorded as per the above standards.

2.3 GENERAL INFORMATION OF THE SAR SYSTEM

DASY5 (**software 5.0 Build 125**) consists of high precision robot, probe alignment sensor, phantom, robot controller, controlled measurement server and near-field probe. The robot includes six axes that can move to the precision position of the DASY5 software defined. The DASY5 software can define the area that is detected by the probe. The robot is connected to controlled box. Controlled measurement server is connected to the controlled robot box. The DAE includes amplifier, signal multiplexing, AD converter, offset measurement and surface detection. It is connected to the Electro-optical coupler (ECO). The ECO performs the conversion from the optical into digital electric signal of the DAE and transfers data to the PC.



A D T

EX3DV3 ISOTROPIC E-FIELD PROBE

CONSTRUCTION	Symmetrical design with triangular core Built-in shielding against static charges PEEK enclosure material (resistant to organic solvents, e.g., DGBE)
FREQUENCY	10 MHz > 6 GHz Linearity: ± 0.2 dB (30 MHz to 6 GHz)
DIRECTIVITY	± 0.3 dB in HSL (rotation around probe axis) ± 0.5 dB in tissue material (rotation normal to probe axis)
DYNAMIC RANGE	10 μ W/g to > 100 mW/g Linearity: ± 0.2 dB (noise: typically < 1 μ W/g)
DIMENSIONS	Overall length: 330 mm (Tip: 20 mm) Tip diameter: 2.5 mm (Body: 12 mm) Typical distance from probe tip to dipole centers: 1 mm
APPLICATION	High precision dosimetric measurements in any exposure scenario (e.g., very strong gradient fields). Only probe which enables compliance testing for frequencies up to 6 GHz with precision of better 30%.

NOTE

1. The Probe parameters have been calibrated by the SPEAG. Please reference "APPENDIX D" for the Calibration Certification Report.
2. For frequencies above 800MHz, calibration in a rectangular wave-guide is used, because wave-guide size is manageable.
3. For frequencies below 800MHz, temperature transfer calibration is used because the wave-guide size becomes relatively large.

TWIN SAM V4.0

CONSTRUCTION	The shell corresponds to the specifications of the Specific Anthropomorphic Mannequin (SAM) phantom defined in IEEE 1528-2003, EN 62209-1 and IEC 62209. It enables the dosimetric evaluation of left and right hand phone usage as well as body mounted usage at the flat phantom region. A cover prevents evaporation of the liquid. Reference markings on the phantom allow the complete setup of all predefined phantom positions and measurement grids by manually teaching three points with the robot.
SHELL THICKNESS	2 ± 0.2 mm
FILLING VOLUME	Approx. 25liters
DIMENSIONS	Height: 810mm; Length: 1000mm; Width: 500mm



SYSTEM VALIDATION KITS:

CONSTRUCTION	Symmetrical dipole with 1/4 balun enables measurement of feedpoint impedance with NWA matched for use near flat phantoms filled with brain simulating solutions. Includes distance holder and tripod adaptor
CALIBRATION	Calibrated SAR value for specified position and input power at the flat phantom in brain simulating solutions
FREQUENCY	5200MHz, 5500MHz
RETURN LOSS	> 20dB at specified validation position
POWER CAPABILITY	> 100W (f < 1GHz); > 40W (f > 1GHz)
OPTIONS	Dipoles for other frequencies or solutions and other calibration conditions upon request

DEVICE HOLDER FOR SAM TWIN PHANTOM

CONSTRUCTION	The device holder for the mobile phone device is designed to cope with different positions given in the standard. It has two scales for the device rotation (with respect to the body axis) and the device inclination (with respect to the line between the ear reference points). The rotation centers for both scales is the ear reference point (ERP). Thus the device needs no repositioning when changing the angles. The holder has been made out of low-loss POM material having the following dielectric parameters: relative permittivity $\epsilon = 3$ and loss tangent $\delta = 0.02$. The amount of dielectric material has been reduced in the closest vicinity of the device, since measurements have suggested that the influence of the clamp on the test results could thus be lowered. The device holder for the portable device makes up of the polyethylene foam. The dielectric parameters of material close to the dielectric parameters of the air.
---------------------	--



A D T

DATA ACQUISITION ELECTRONICS

CONSTRUCTION

The data acquisition electronics (DAE3) consists of a highly sensitive electrometer grade preamplifier with auto-zeroing, a channel and gain-switching multiplex, a fast 16 bit AD converter and a command decoder and control logic unit. Transmission to the measurement server is accomplished through an optical downlink for data and status information as well as an optical uplink for commands and the clock. The mechanical probe is mounting device includes two different sensor systems for frontal and sideways probe contacts. They are used for mechanical surface detection and probe collision detection. The input impedance of the DAE3 box is 200M Ω ; the inputs are symmetrical and floating. Common mode rejection is above 80 dB.



A D T

2.4 TEST EQUIPMENT

FOR SAR MEASUREMENT

ITEM	NAME	BRAND	TYPE	SERIES NO.	DATE OF CALIBRATION	DUE DATE OF CALIBRATION
1	SAM Phantom	S & P	QD000 P40 CA	TP-1485	NA	NA
2	Signal Generator	Anritsu	68247B	984703	May 21, 2009	May 20, 2010
3	E-Field Probe	S & P	EX3DV3	3504	Jan. 26, 2010	Jan. 25, 2011
4	DAE	S & P	DAE	510	Dec. 16, 2009	Dec. 15, 2010
5	Robot Positioner	Staubli Unimation	NA	NA	NA	NA
6	Validation Dipole	S & P	D5GHzV2	1018	Jan. 22, 2010	Jan. 21, 2011

NOTE: Before starting the measurement, all test equipment shall be warmed up for 30min.

FOR TISSUE PROPERTY

ITEM	NAME	BRAND	TYPE	SERIES NO.	DATE OF CALIBRATION	DUE DATE OF CALIBRATION
1	Network Analyzer	Agilent	E8358A	US41480538	Dec. 03, 2009	Dec. 02, 2010
2	Dielectric Probe	Agilent	85070D	US01440176	NA	NA

NOTE:

1. Before starting, all test equipment shall be warmed up for 30min.
2. The tolerance ($k=1$) specified by Agilent for general dielectric measurements, deriving from inaccuracies in the calibration data, analyzer drift, and random errors, are usually $\pm 2.5\%$ and $\pm 5\%$ for measured permittivity and conductivity, respectively. However, the tolerances for the conductivity is smaller for material with large loss tangents, i.e., less than $\pm 2.5\%$ ($k=1$). It can be substantially smaller if more accurate methods are applied.



2.5 GENERAL DESCRIPTION OF THE SPATIAL PEAK SAR EVALUATION

The DASY5 post-processing software (SEMCAD) automatically executes the following procedures to calculate the field units from the micro-volt readings at the probe connector. The parameters used in the evaluation are stored in the configuration modules of the software:

Probe parameters:	- Sensitivity	Norm _i , a _{i0} , a _{i1} , a _{i2}
	- Conversion factor	ConvF _i
	- Diode compression point	dcp _i
Device parameters:	- Frequency	F
	- Crest factor	Cf
Media parameters:	- Conductivity	σ
	- Density	ρ

The first step of the evaluation is a linearization of the filtered input signal to account for the compression characteristics of the detector diode. The compensation depends on the input signal, the diode type and the DC-transmission factor from the diode to the evaluation electronics. If the exciting field is pulsed, the crest factor of the signal must be known to correctly compensate for peak power. The formula for each channel can be given as:

$$V_i = U_i + U_i^2 \cdot \frac{cf}{dcp_i}$$

V _i	=compensated signal of channel i	(i = x, y, z)
U _i	=input signal of channel i	(i = x, y, z)
Cf	=crest factor of exciting field	(DASY parameter)
dcp _i	=diode compression point	(DASY parameter)

From the compensated input signals the primary field data for each channel can be evaluated:

$$\text{E-field probes: } E_i = \sqrt{\frac{V_i}{\text{Norm}_i \cdot \text{ConvF}}}$$

$$\text{H-field probes: } H_i = \sqrt{V_i} \cdot \frac{a_{i0} + a_{i1}f + a_{i2}f^2}{f}$$

- V_i = compensated signal of channel I (i = x, y, z)
- Norm_i = sensor sensitivity of channel i $\mu\text{V}/(\text{V/m})^2$ for E-field Probes (i = x, y, z)
- ConvF = sensitivity enhancement in solution
- a_{ij} = sensor sensitivity factors for H-field probes
- F = carrier frequency [GHz]
- E_i = electric field strength of channel i in V/m
- H_i = magnetic field strength of channel i in A/m

The RSS value of the field components gives the total field strength (Hermitian magnitude):

$$E_{tot} = \sqrt{E_x^2 + E_y^2 + E_z^2}$$

The primary field data are used to calculate the derived field units.

$$SAR = E_{tot}^2 \cdot \frac{\sigma}{\rho \cdot 1'000}$$

- SAR = local specific absorption rate in mW/g
- E_{tot} = total field strength in V/m
- σ = conductivity in [mho/m] or [Siemens/m]
- ρ = equivalent tissue density in g/cm³



A D T

Note that the density is set to 1, to account for actual head tissue density rather than the density of the tissue simulating liquid. The entire evaluation of the spatial peak values is performed within the Post-processing engine (SEMCAD). The system always gives the maximum values for the 1g and 10g cubes. The algorithm to find the cube with highest averaged SAR is divided into the following stages:

1. The extraction of the measured data (grid and values) from the Zoom Scan
2. The calculation of the SAR value at every measurement point based on all stored data (A/D values and measurement parameters)
3. The generation of a high-resolution mesh within the measured volume
4. The interpolation of all measured values from the measurement grid to the high-resolution grid
5. The extrapolation of the entire 3-D field distribution to the phantom surface over the distance from sensor to surface
6. The calculation of the averaged SAR within masses of 1g and 10g.

The probe is calibrated at the center of the dipole sensors that is located 1 to 2.7mm away from the probe tip. During measurements, the probe stops shortly above the phantom surface, depending on the probe and the surface detecting system. Both distances are included as parameters in the probe configuration file. The software always knows exactly how far away the measured point is from the surface. As the probe cannot directly measure at the surface, the values between the deepest measured point and the surface must be extrapolated. The angle between the probe axis and the surface normal line is less than 30 degree.



A D T

The maximum search is automatically performed after each area scan measurement. It is based on splines in two or three dimensions. The procedure can find the maximum for most SAR distributions even with relatively large grid spacing. After the area scanning measurement, the probe is automatically moved to a position at the interpolated maximum. The following scan can directly use this position for reference, e.g., for a finer resolution grid or the cube evaluations. The 1g and 10g peak evaluations are only available for the predefined cube 7 x 7 x 7 scans. The routines are verified and optimized for the grid dimensions used in these cube measurements. The measured volume of 30 x 30 x 30mm contains about 30g of tissue. The first procedure is an extrapolation (incl. boundary correction) to get the points between the lowest measured plane and the surface. The next step uses 3D interpolation to get all points within the measured volume in a 1mm grid (42875 points). In the last step, a 1g cube is placed numerically into the volume and its averaged SAR is calculated. This cube is moved around until the highest averaged SAR is found. If the highest SAR is found at the edge of the measured volume, the system will issue a warning: higher SAR values might be found outside of the measured volume. In that case the cube measurement can be repeated, using the new interpolated maximum as the center.

3. DESCRIPTION OF SUPPORT UNITS

The EUT has been tested as an independent unit.

4.1. DESCRIPTION OF TEST POSITION

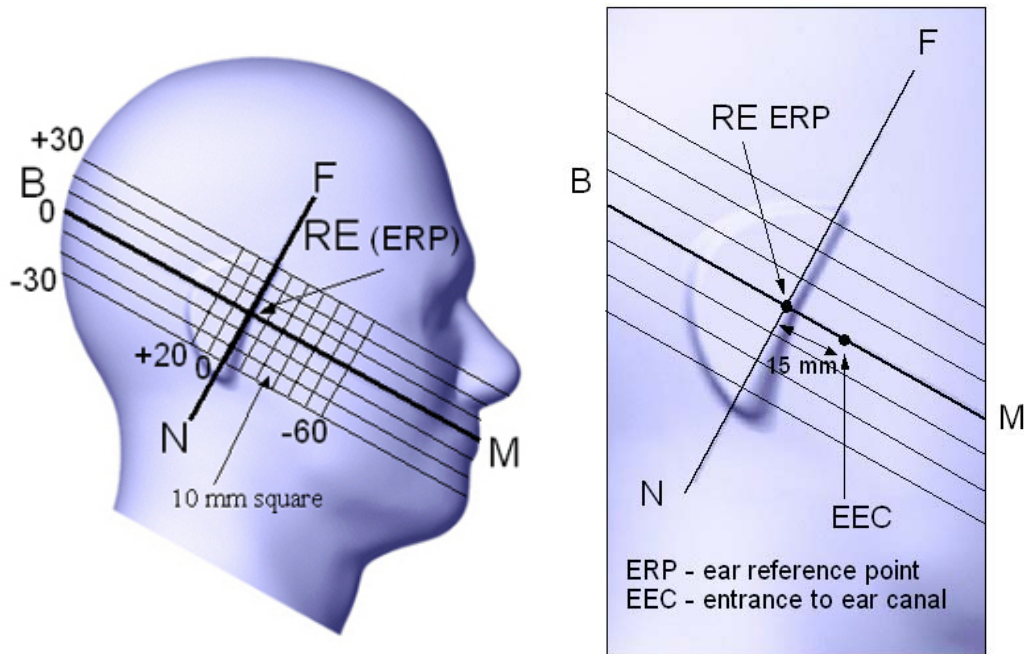

FIGURE 3.1

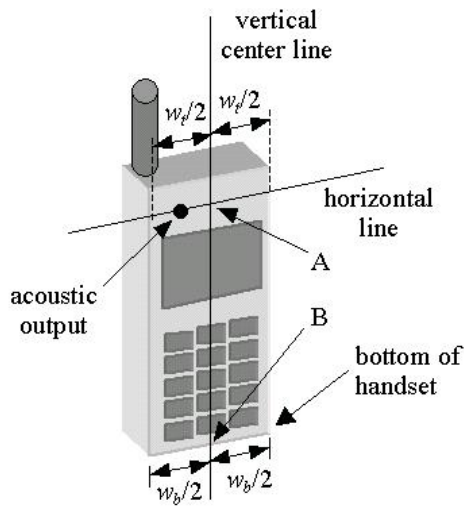

FIGURE 3.1a

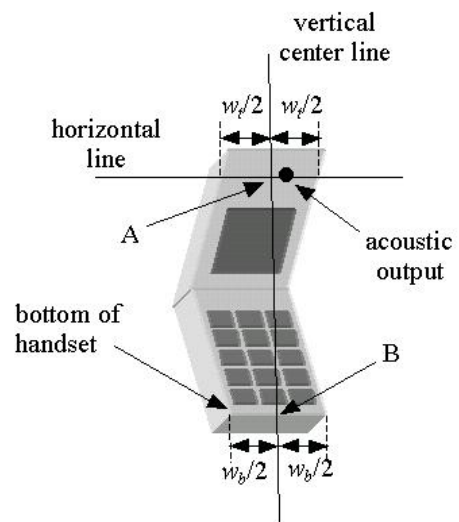
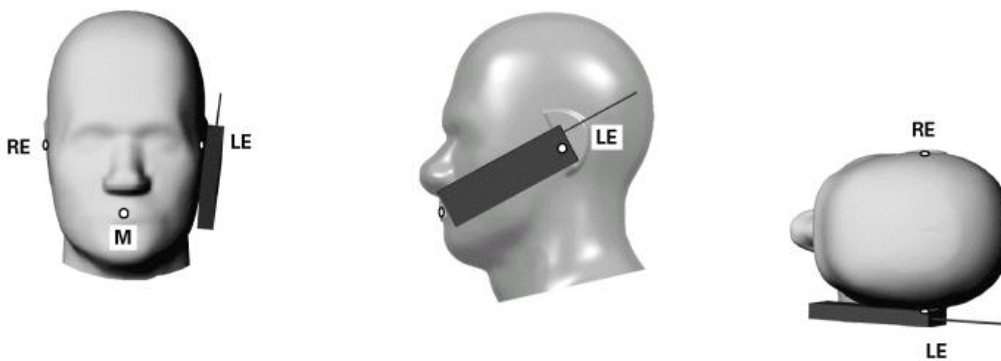

FIGURE 3.1b

4.1.1 TOUCH/CHEEK TEST POSITION

The head position in Figure 3.1, the ear reference points ERP are 15mm above entrance to ear canal along the B-M line. The line N-F (Neck-Front) is perpendicular to the B-M (Back Mouth) line. The handset device in Figure 3.1a and 3.1b, The vertical centerline pass through two points on the front side of handset: the midpoint of the width w_t of the handset at the level of the acoustic output (point A) and the midpoint of the width W_b of the bottom of the handset (point B). The vertical centerline is perpendicular to the horizontal line and pass through the center of the acoustic output. The point A touches the ERP and the vertical centerline of the handset is parallel to the B-M line. While maintaining the point A contact with the ear(ERP), rotate the handset about the line NF until any point on handset is in contact with the cheek of the phantom



TOUCH/CHEEK POSITION FIGURE

4.1.2 TILT TEST POSITION

Adjust the device in the cheek position. While maintaining a point of the handset contact in the ear, move the bottom of the handset away from the mouth by an angle of 15 degrees.

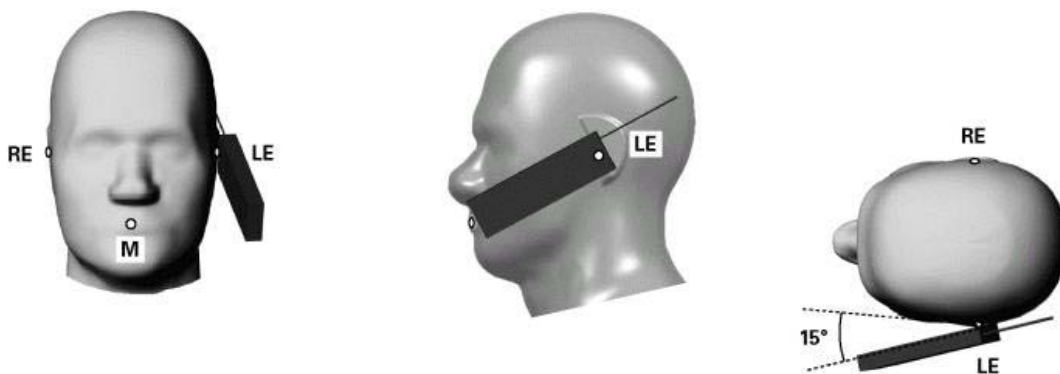

TILT POSITION FIGURE

4.1.3 BODY-WORN CONFIGURATION

The handset device attached the belt clip or the holster. The keypad face of the handset is against with the bottom of the flat phantom face and the bottom of the keypad face contact to the bottom of the flat phantom.

When multiple accessories that do not contain metallic components are supplied with the device, the device may be tested with only the accessory that dictates the closest spacing to the body. When multiple accessories that contain metallic components are supplied with the device, the device must be tested with each accessory that contains a unique metallic component. If multiple accessories share an identical metallic component (e.g., the same metallic belt-clip used with different holsters with no other metallic components), only accessory that dictates the closest spacing to the body must be tested.



5. RECIPES FOR TISSUE SIMULATING LIQUIDS

For the measurement of the field distribution inside the SAM phantom, the phantom must be filled with 25 liters of tissue simulation liquid.

The following is a short description of some typical ingredients used in the Simulating Liquids :

- **WATER-** Deionized water (pure H₂O), resistivity ≥ 16 M - as basis for the liquid
- **SUGAR-** Refined sugar in crystals, as available in food shops - to reduce relative permittivity
- **SALT-** Pure NaCl - to increase conductivity
- **CELLULOSE-** Hydroxyethyl-cellulose, medium viscosity (75-125mPa.s, 2% in water, 20_C),
CAS # 54290 - to increase viscosity and to keep sugar in solution
- **PRESERVATIVE-** Preventol D-7 Bayer AG, D-51368 Leverkusen, CAS # 55965-84-9 - to prevent the spread of bacteria and molds
- **DGMBE-** Diethylenglycol-monobuthyl ether (DGMBE), Fluka Chemie GmbH, CAS # 112-34-5 - to reduce relative permittivity

THE INFORMATION FOR 5GHz SIMULATING LIQUID

The 5GHz liquids was purchased from SPEAG.

Body liquid model: HSL 5800, P/N: SL AAH 5800 AA

Head liquid model: M 5800, P/N: SL AAM 580 AD

5GHz liquids contain the following ingredients:

Water 64 - 78%

Mineral Oil 11 - 18%

Emulsifiers 9 - 15%

Additives and Salt 2 - 3%

Testing the liquids using the Agilent Network Analyzer E8358A and Agilent Dielectric Probe Kit 85070D. The testing procedure is following as

1. Turn Network Analyzer on and allow at least 30min. warm up.
2. Mount dielectric probe kit so that interconnecting cable to Network Analyzer will not be moved during measurements or calibration.
3. Pour de-ionized water and measure water temperature ($\pm 1^\circ$).
4. Set water temperature in Agilent-Software (Calibration Setup).
5. Perform calibration.
6. Validate calibration with dielectric material of known properties (e.g. polished ceramic slab with $>8\text{mm}$ thickness $\epsilon' = 10.0$, $\epsilon'' = 0.0$). If measured parameters do not fit within tolerance, repeat calibration (± 0.2 for ϵ' : ± 0.1 for ϵ'').
7. Conductivity can be calculated from ϵ'' by $\sigma = \omega \epsilon_0 \epsilon'' = \epsilon'' f [\text{GHz}] / 18$.
8. Measure liquid shortly after calibration. Repeat calibration every hour.
9. Stir the liquid to be measured. Take a sample ($\sim 50\text{ml}$) with a syringe from the center of the liquid container.
10. Pour the liquid into a small glass flask. Hold the syringe at the bottom of the flask to avoid air bubbles.
11. Put the dielectric probe in the glass flask. Check that there are no air bubbles in front of the opening in the dielectric probe kit.
12. Perform measurements.
13. Adjust medium parameters in DASY5 for the frequencies necessary for the measurements ('Setup Config', select medium (e.g. Brain 900MHz) and press 'Option'-button.
14. Select the current medium for the frequency of the validation (e.g. Setup Medium Brain 900MHz).



A D T

FOR WLAN 5GHZ BAND SIMULATING LIQUID

LIQUID TYPE		HSL-5800		
SIMULATING LIQUID TEMP.		23.0		
TEST DATE		Apr. 16, 2010		
TESTED BY		Dylan Chiou		
FREQ. (MHz)	LIQUID PARAMETER	STANDARD VALUE	MEASUREMENT VALUE	ERROR PERCENTAGE (%)
5200	Permittivity (ϵ)	35.99	36.90	2.53
5320		35.85	36.70	2.38
5500		35.64	36.40	2.12
5680		35.44	36.10	1.87
5200	Conductivity (σ) S/m	4.66	4.66	0.00
5320		4.78	4.80	0.46
5500		4.96	5.02	1.16
5680		5.15	5.23	1.61
Dielectric Parameters Required at 22°C				

LIQUID TYPE		HSL-5800		
SIMULATING LIQUID TEMP.		22.9		
TEST DATE		Apr. 17, 2010		
TESTED BY		Dylan Chiou		
FREQ. (MHz)	LIQUID PARAMETER	STANDARD VALUE	MEASUREMENT VALUE	ERROR PERCENTAGE (%)
5200	Permittivity (ϵ)	35.99	36.90	2.53
5320		35.85	36.70	2.38
5500		35.64	36.30	2.40
5680		35.44	36.10	1.87
5200	Conductivity (σ) S/m	4.66	4.66	0.00
5320		4.78	4.80	0.46
5500		4.96	5.02	1.16
5680		5.15	5.24	1.81
Dielectric Parameters Required at 22°C				



A D T

LIQUID TYPE		HSL-5800		
SIMULATING LIQUID TEMP.		22.5		
TEST DATE		Apr. 18, 2010		
TESTED BY		Dylan Chiou		
FREQ. (MHz)	LIQUID PARAMETER	STANDARD VALUE	MEASUREMENT VALUE	ERROR PERCENTAGE (%)
5200	Permittivity (ϵ)	35.99	36.50	1.42
5320		35.85	36.40	1.54
5500		35.64	36.10	1.28
5520		35.62	36.00	1.07
5580		35.55	35.90	0.98
5600		35.53	35.90	1.05
5620		35.51	35.90	1.11
5680		35.44	35.70	0.74
5700		35.41	35.70	0.81
5200		Conductivity (σ) S/m	4.66	4.61
5320	4.78		4.75	-0.59
5500	4.96		4.96	-0.05
5520	4.98		4.98	-0.06
5580	5.04		5.06	0.31
5600	5.07		5.09	0.49
5620	5.09		5.11	0.48
5680	5.15		5.18	0.64
5700	5.17	5.20	0.63	
Dielectric Parameters Required at 22°C				



A D T

LIQUID TYPE		HSL-5800		
SIMULATING LIQUID TEMP.		22.6		
TEST DATE		Apr. 19, 2010		
TESTED BY		Dylan Chiou		
FREQ. (MHz)	LIQUID PARAMETER	STANDARD VALUE	MEASUREMENT VALUE	ERROR PERCENTAGE (%)
5200	Permittivity (ϵ)	35.99	36.9	2.53
5320		35.85	36.7	2.38
5500		35.64	36.3	1.84
5520		35.62	36.3	1.91
5580		35.55	36.1	1.54
5600		35.53	36.1	1.61
5620		35.51	36.1	1.67
5680		35.44	36.1	1.87
5700		35.41	35.9	1.37
5200		Conductivity (σ) S/m	4.66	4.66
5320	4.78		4.8	0.46
5500	4.96		5.02	1.16
5520	4.98		5.04	1.14
5580	5.04		5.12	1.50
5600	5.07		5.14	1.48
5620	5.09		5.17	1.66
5680	5.15		5.24	1.81
5700	5.17	5.26	1.79	
Dielectric Parameters Required at 22°C				



A D T

LIQUID TYPE		MSL-5800		
SIMULATING LIQUID TEMP.		22.5		
TEST DATE		Apr. 20, 2010		
TESTED BY		Dylan Chiou		
FREQ. (MHz)	LIQUID PARAMETER	STANDARD VALUE	MEASUREMENT VALUE	ERROR PERCENTAGE (%)
5200	Permittivity (ϵ)	49.01	51.4	4.87
5320		48.85	51.2	4.81
5500		48.61	50.9	4.31
5680		48.36	50.5	4.42
5200	Conductivity (σ) S/m	5.30	5.37	1.33
5320		5.44	5.52	1.48
5500		5.65	5.79	2.48
5680		5.86	6.06	3.42
Dielectric Parameters Required at 22°C				



6. SYSTEM VALIDATION

The system validation was performed in the flat phantom with equipment listed in the following table. Since the SAR value is calculated from the measured electric field, dielectric constant and conductivity of the body tissue and the SAR is proportional to the square of the electric field. So, the SAR value will be also proportional to the RF power input to the system validation dipole under the same test environment. In our system validation test, 250mW RF input power was used.

6.1 TEST PROCEDURE

Before the system performance check, we need only to tell the system which components (probe, medium, and device) are used for the system performance check; the system will take care of all parameters. The dipole must be placed beneath the flat section of the SAM Twin Phantom with the correct distance holder in place. The distance holder should touch the phantom surface with a light pressure at the reference marking (little cross) and be oriented parallel to the long side of the phantom. Accurate positioning is not necessary, since the system will search for the peak SAR location, except that the dipole arms should be parallel to the surface. The device holder for mobile phones can be left in place but should be rotated away from the dipole.

1. The "Power Reference Measurement" and "Power Drift Measurement" jobs are located at the beginning and end of the batch process. They measure the field drift at one single point in the liquid over the complete procedure. The indicated drift is mainly the variation of the amplifier output power. If it is too high (above ± 0.1 dB), the system performance check should be repeated; some amplifiers have very high drift during warm-up. A stable amplifier gives drift results in the DASY system below ± 0.02 dB.
2. The "Surface Check" job tests the optical surface detection system of the DASY system by repeatedly detecting the surface with the optical and mechanical surface detector and comparing the results. The output gives the detecting heights of both systems, the difference between the two systems and the standard deviation of the detection repeatability. Air bubbles or refraction in the liquid due to separation of the sugar-water mixture gives poor repeatability (above ± 0.1 mm). In that case it is better to abort the system performance check and stir the liquid.



3. The "Area Scan" job measures the SAR above the dipole on a plane parallel to the surface. It is used to locate the approximate location of the peak SAR. The proposed scan uses large grid spacing for faster measurement; due to the symmetric field, the peak detection is reliable. If a finer graphic is desired, the grid spacing can be reduced. Grid spacing and orientation have no influence on the SAR result.
4. The "Zoom Scan" job measures the field in a volume around the peak SAR value assessed in the previous "Area Scan" job (for more information see the application note on SAR evaluation).

About the validation dipole positioning uncertainty, the constant and low loss dielectric spacer is used to establish the correct distance between the top surface of the dipole and the bottom surface of the phantom, the error component introduced by the uncertainty of the distance between the liquid (i.e., phantom shell) and the validation dipole in the DASY5 system is less than ± 0.1 mm.

$$SAR_{tolerance} [\%] = 100 \times \left(\frac{(a + d)^2}{a^2} - 1 \right)$$

As the closest distance is 10mm, the resulting tolerance $SAR_{tolerance}[\%]$ is <2%.



6.2 VALIDATION RESULTS

SYSTEM VALIDATION TEST OF SIMULATING LIQUID					
FREQUENCY (MHz)	REQUIRED SAR (mW/g)	MEASURED SAR (mW/g)	DEVIATION (%)	SEPARATION DISTANCE	TESTED DATE
HSL 5200	7.95 (1g)	8.33	4.78	10mm	Apr. 16, 2010
HSL 5500	8.46 (1g)	8.69	2.72	10mm	Apr. 16, 2010
HSL 5200	7.95 (1g)	8.29	4.28	10mm	Apr. 17, 2010
HSL 5500	8.46 (1g)	8.70	2.84	10mm	Apr. 17, 2010
HSL 5200	7.95 (1g)	8.29	4.28	10mm	Apr. 18, 2010
HSL 5500	8.46 (1g)	8.64	2.13	10mm	Apr. 18, 2010
HSL 5200	7.95 (1g)	8.37	5.28	10mm	Apr. 19, 2010
HSL 5500	8.46 (1g)	8.74	3.31	10mm	Apr. 19, 2010
MSL 5200	8.14 (1g)	7.89	-3.07	10mm	Apr. 20, 2010
MSL 5500	8.71 (1g)	8.56	-1.72	10mm	Apr. 20, 2010
TESTED BY	Dylan Chiou				

NOTE: Please see Appendix for the photo of system validation test.

6.3 SYSTEM VALIDATION UNCERTAINTIES

In the table below, the system validation uncertainty with respect to the analytically assessed SAR value of a dipole source as given in the IEEE 1528 standard is given. This uncertainty is smaller than the expected uncertainty for mobile phone measurements due to the simplified setup and the symmetric field distribution.

Error Description	Tolerance (±%)	Probability Distribution	Divisor	(C _i)		Standard Uncertainty (±%)		(v _i)
				(1g)	(10g)	(1g)	(10g)	
Measurement System								
Probe Calibration	6.55	Normal	1	1	1	6.55	6.55	∞
Axial Isotropy	0.50	Rectangular	√3	0.7	0.7	0.20	0.20	∞
Hemispherical Isotropy	2.60	Rectangular	√3	0.7	0.7	1.05	1.05	∞
Boundary effects	1.00	Rectangular	√3	1	1	0.58	0.58	∞
Linearity	0.60	Rectangular	√3	1	1	0.35	0.35	∞
System Detection Limits	1.00	Rectangular	√3	1	1	0.58	0.58	∞
Readout Electronics	0.30	Normal	1	1	1	0.30	0.30	∞
Response Time	0.80	Rectangular	√3	1	1	0.46	0.46	∞
Integration Time	2.60	Rectangular	√3	1	1	1.50	1.50	∞
RF Ambient Noise	3.00	Rectangular	√3	1	1	1.73	1.73	∞
RF Ambient Reflections	3.00	Rectangular	√3	1	1	1.73	1.73	∞
Probe Positioner	0.80	Rectangular	√3	1	1	0.46	0.46	∞
Probe Positioning	9.90	Rectangular	√3	1	1	5.72	5.72	∞
Max. SAR Eval.	4.00	Rectangular	√3	1	1	2.31	2.31	∞
Dipole Related								
Dipole Axis to Liquid Distance	2.00	Rectangular	√3	1	1	1.15	1.15	145
Input Power Drift	5.00	Rectangular	√3	1	1	2.89	2.89	∞
Phantom and Tissue parameters								
Phantom Uncertainty	4.00	Rectangular	√3	1	1	2.31	2.31	∞
Liquid Conductivity (target)	5.00	Rectangular	√3	0.64	0.43	1.85	1.24	∞
Liquid Conductivity (measurement)	3.97	Normal	1	0.64	0.43	2.54	1.71	∞
Liquid Permittivity (target)	5.00	Rectangular	√3	0.6	0.49	1.73	1.41	∞
Liquid Permittivity (measurement)	4.90	Normal	1	0.6	0.49	2.94	2.40	∞
Combined Standard Uncertainty						11.32	10.90	
Coverage Factor for 95%						Kp=2		
Expanded Uncertainty (K=2)						22.64	21.80	

NOTE: About the system validation uncertainty assessment, please reference the section 7.

7. TEST RESULTS

7.1 TEST PROCEDURES

Use the software to control the EUT channel and transmission power. Then record the conducted power before the testing. Place the EUT to the specific test location. After the testing, must writing down the conducted power of the EUT into the report. The SAR value was calculated via the 3D spline interpolation algorithm that has been implemented in the software of DASY5 SAR measurement system manufactured and calibrated by SPEAG. According to the IEEE 1528 standards, the recommended procedure for assessing the peak spatial-average SAR value consists of the following steps:

- Power reference measurement
- Verification of the power reference measurement
- Area scan
- Zoom scan
- Power reference measurement

The area scan was performed for the highest spatial SAR location. The zoom scan with 30mm x 30mm x 30mm volume was performed for SAR value averaged over 1g and 10g spatial volumes.



A D T

In the zoom scan, the distance between the measurement point at the probe sensor location (geometric center behind the probe tip) and the phantom surface is 3mm and maintained at a constant distance of ± 0.5 mm during a zoom scan to determine peak SAR locations. The distance is 3mm between the first measurement point and the bottom surface of the phantom. The secondary measurement point to the bottom surface of the phantom is with 8mm separation distance. The cube size is 7 x 7 x 7 points consists of 343 points and the grid space is 5mm.

The measurement time is 0.5s at each point of the zoom scan. The probe boundary effect compensation shall be applied during the SAR test. Because of the tip of the probe to the Phantom surface separated distances are longer than half a tip probe diameter.

In the area scan, the separation distance is 3mm between the each measurement point and the phantom surface. The scan size shall be included the transmission portion of the EUT. The measurement time is the same as the zoom scan. At last the reference power drift shall be less than $\pm 5\%$.



7.2 MEASURED SAR RESULTS

Configuration: Barcode reader: BB Imager, 1.5x Battery

Stand-alone SAR (1g)				
HEAD	RIGHT		LEFT	
	CHEEK	TILT	CHEEK	TILT
802.11a				
Ch 40: 5200MHz	0.276	0.262	0.290	0.284
Ch 64: 5320MHz	0.503	0.542	0.559	0.596
Ch 100: 5500MHz	0.379	0.392	0.384	0.399
Ch 104: 5520MHz	0.338	0.348	0.363	0.374
Ch 116: 5580MHz	0.370	0.382	0.293	0.329
Ch 120: 5600MHz	0.395	0.399	0.342	0.343
Ch 124: 5620MHz	0.456	0.460	0.338	0.366
Ch 136: 5680MHz	0.390	0.383	0.392	0.384
Ch 140: 5700MHz	0.299	0.295	0.256	0.268

Configuration:

Front: Barcode reader: BB Imager, 1.5x Battery, Ridged holster, Headset

Bottom: Barcode reader: BB Imager, 1.5x Battery, Fabric holster, Headset

	BODY	
Mode	Front	Bottom
802.11a		
Ch 40: 5200MHz	0.035	0.0033
Ch 64: 5320MHz	0.051	0.0081
Ch 136: 5680MHz	0.052	0.00798

NOTE:

1. Test configuration of each mode is described in section 4.1.
2. In this testing, the limit for General Population Spatial Peak averaged over 1g, **1.6 W/kg**, is applied.
3. Please see the Appendix A for the data.
4. The variation of the EUT conducted power measured before and after SAR testing should not over 5%.
5. Temperature of Liquid is 22±1°C
6. For 5150~5250 and 5250~5350 MHz band: Per KDB 447498, when 1-g SAR for the highest output channel is less than 0.8 W/kg, testing for the other channels is not required.
7. The EUT have been pre-tested and found "BB / QWERTY + 1.5X battery" was the worst case configuration for final test
8. For body position, the EUT front facing the phantom was tested with Ridged holster and the EUT bottom facing the phantom was tested with fabric holster. This is due to the facts that The correspond holster will limit the orientation of EUT when it is stored in the holste



A D T

7.3 SAR LIMITS

HUMAN EXPOSURE	SAR (W/kg)	
	(GENERAL POPULATION / UNCONTROLLED EXPOSURE ENVIRONMENT)	(OCCUPATIONAL / CONTROLLED EXPOSURE ENVIRONMENT)
Spatial Average (whole body)	0.08	0.4
Spatial Peak (averaged over 1 g)	1.6	8.0
Spatial Peak (hands / wrists / feet / ankles averaged over 10 g)	4.0	20.0

NOTE:

1. This limits accord to 47 CFR 2.1093 – Safety Limit.
2. The EUT property been complied with the partial body exposure limit under the general population environment.

8. INFORMATION ON THE TESTING LABORATORIES

We, Bureau Veritas Consumer Products Services (H.K.) Ltd., Taoyuan Branch, were founded in 1988 to provide our best service in EMC, Radio, Telecom and Safety consultation. Our laboratories are accredited and approved according to ISO/IEC 17025.

Copies of accreditation certificates of our laboratories obtained from approval agencies can be downloaded from our web site: www.adt.com.tw/index.5/phtml. If you have any comments, please feel free to contact us at the following:

Linko EMC/RF Lab:

Tel: 886-2-26052180

Fax: 886-2-26051924

Hsin Chu EMC/RF Lab:

Tel: 886-3-5935343

Fax: 886-3-5935342

Hwa Ya EMC/RF/Safety/Telecom Lab:

Tel: 886-3-3183232

Fax: 886-3-3185050

Web Site: www.adt.com.tw

The address and road map of all our labs can be found in our web site also.

---END---

APPENDIX A: TEST DATA

Liquid Level Photo

Tissue HSL5800MHz D=153mm - 4/16

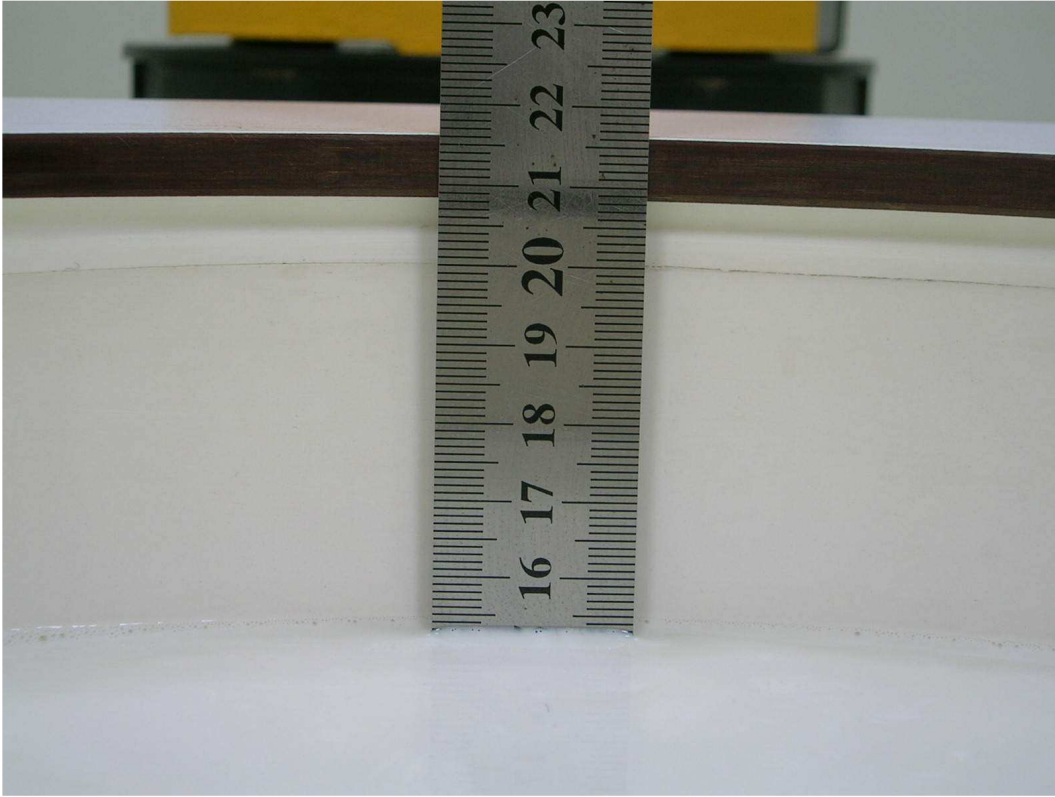

Tissue HSL5800MHz D=152mm - 4/17

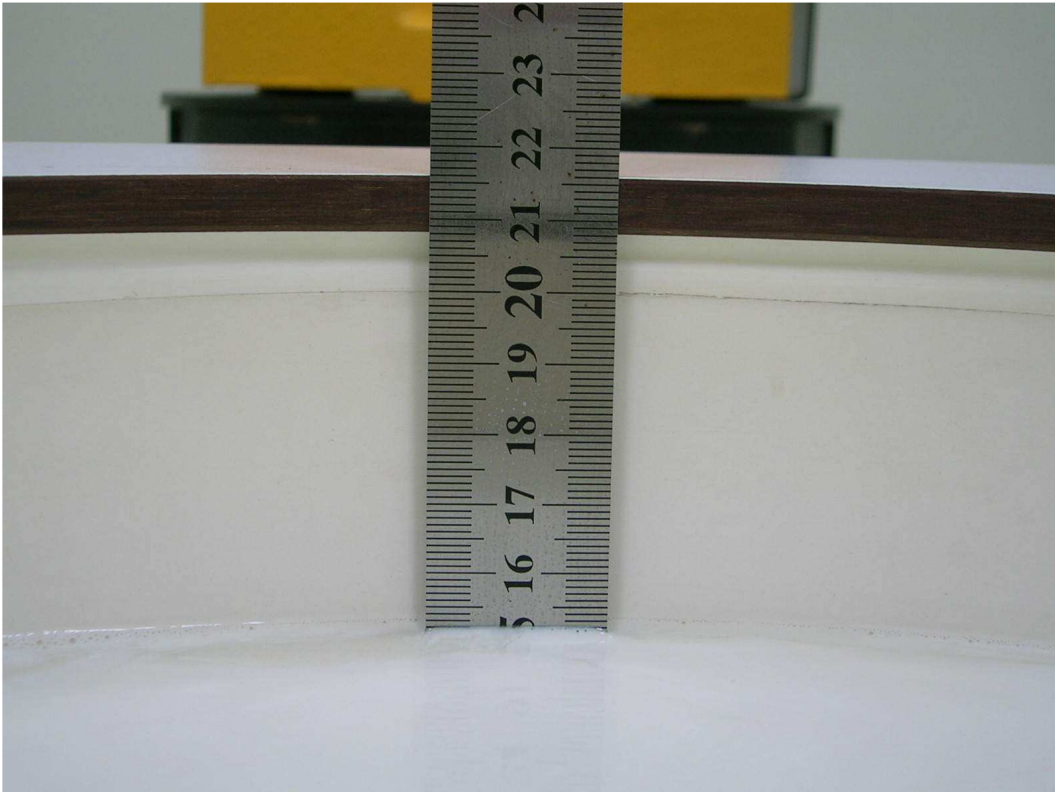

Tissue HSL5800MHz D=152mm - 4/18

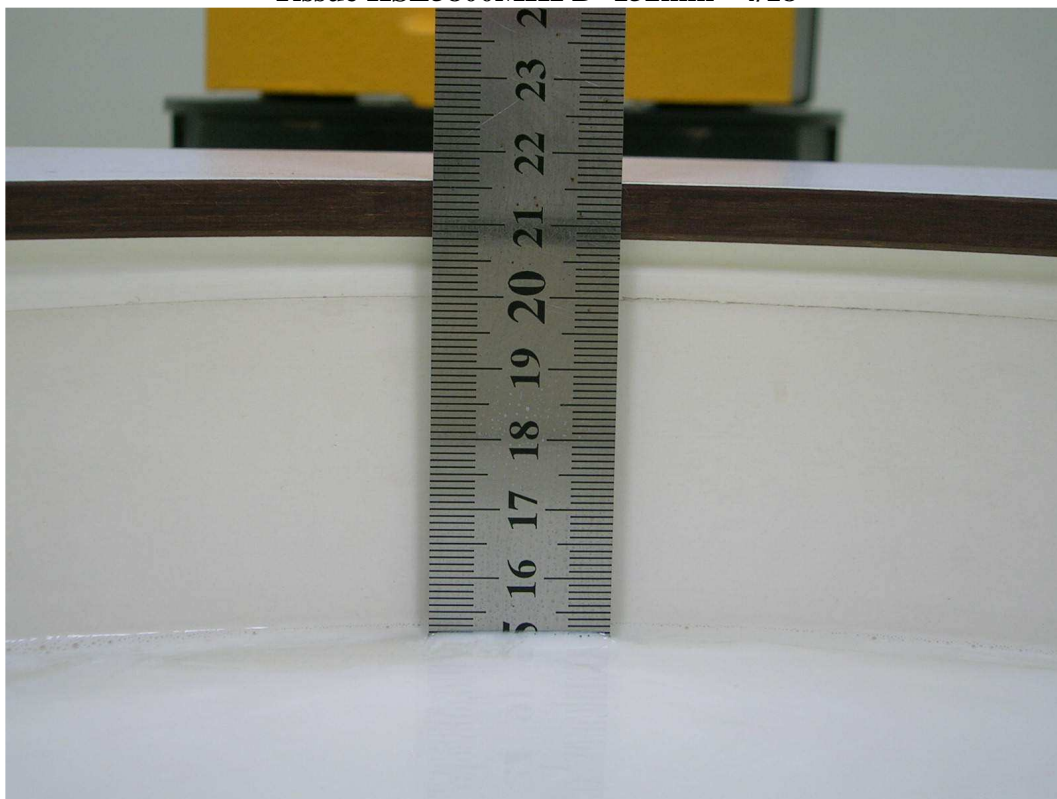

Tissue HSL5800MHz D=152mm - 4/19

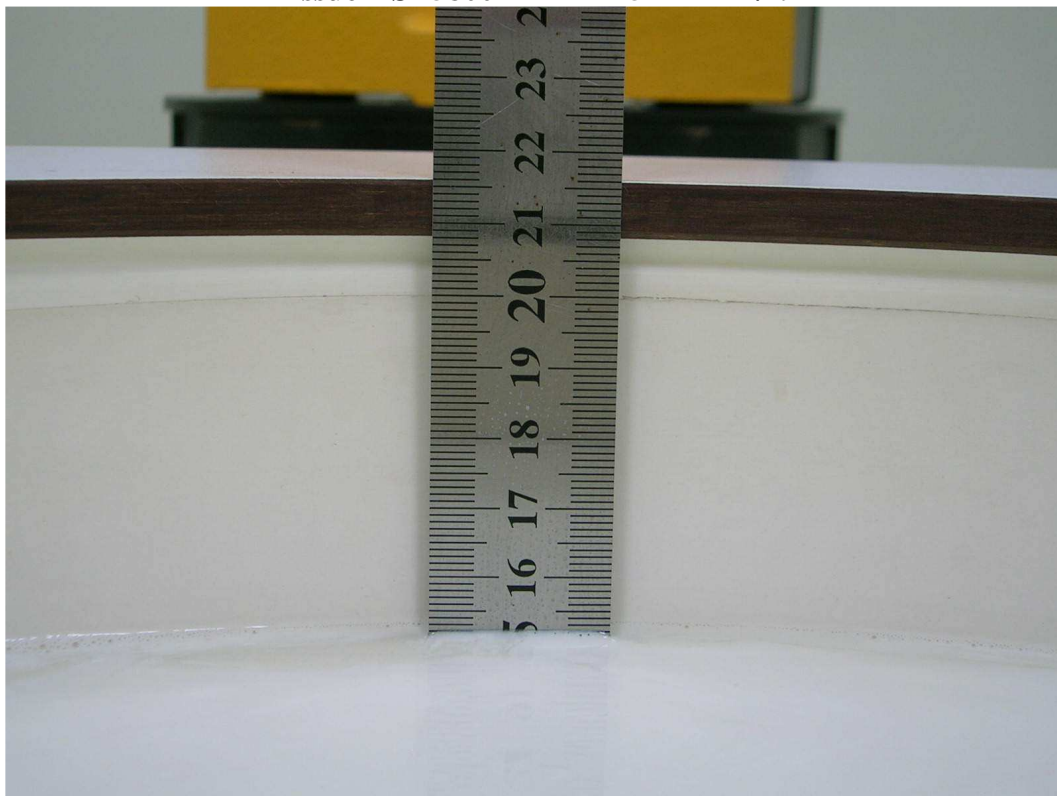

Tissue MSL5800MHz D=154mm - 4/20



Test Laboratory: Bureau Veritas ADT

M01-A6_2D-Right Head-Cheek-11a-Ch40 / 1.5x Batt

DUT: EDA ; Type: MC75A6

Communication System: WiFi ; Frequency: 5200 MHz ; Duty Cycle: 1:1

Medium: HSL5800 Medium parameters used: $f = 5200$ MHz; $\sigma = 4.66$ mho/m; $\epsilon_r = 36.9$; $\rho = 1000$ kg/m³

Phantom section: Right Section ; DUT test position : Cheek ; Modulation type: BPSK

DASY5 Configuration:

- Probe: EX3DV3 - SN3504; ConvF(4.87, 4.87, 4.87); Calibrated: 2010/1/26
- Sensor-Surface: 2.5mm (Mechanical Surface Detection)
- Electronics: DAE3 Sn510; Calibrated: 2009/12/16
- Phantom: SAM with CRP; Type: SAM; Serial: TP-1485
- Measurement SW: DASY5, V5.2 Build 157; SEMCAD X Version 14.0 Build 57

Touch Position - Ch40/Area Scan (10x20x1): Measurement grid: dx=10mm, dy=10mm

Maximum value of SAR (measured) = 0.433 mW/g

Touch Position - Ch40/Zoom Scan (7x7x9)/Cube 0: Measurement grid: dx=4mm, dy=4mm, dz=2.5mm

Reference Value = 10.4 V/m; Power Drift = -0.102 dB

Peak SAR (extrapolated) = 0.923 W/kg

SAR(1 g) = 0.276 mW/g; SAR(10 g) = 0.093 mW/g

Maximum value of SAR (measured) = 0.452 mW/g

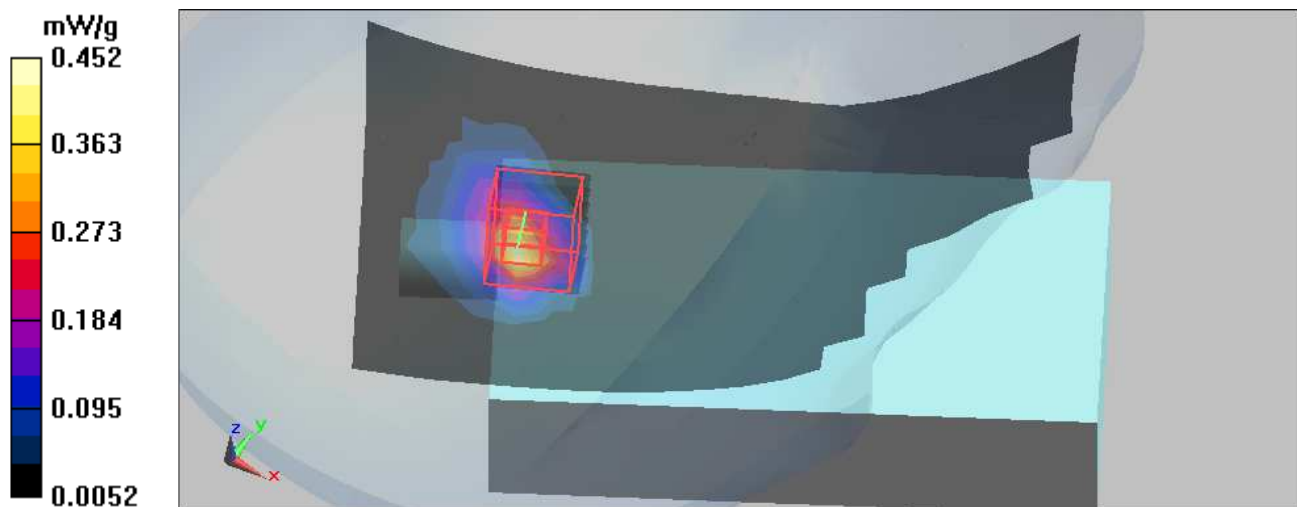

Test Laboratory: Bureau Veritas ADT

M02-A6_2D-Right Head-Cheek-11a-Ch64 / 1.5x Batt

DUT: EDA ; Type: MC75A6

Communication System: WiFi ; Frequency: 5320 MHz ; Duty Cycle: 1:1

Medium: HSL5800 Medium parameters used: $f = 5320 \text{ MHz}$; $\sigma = 4.8 \text{ mho/m}$; $\epsilon_r = 36.7$; $\rho = 1000 \text{ kg/m}^3$

Phantom section: Right Section ; DUT test position : Cheek ; Modulation type: BPSK

DASY5 Configuration:

- Probe: EX3DV3 - SN3504; ConvF(4.62, 4.62, 4.62); Calibrated: 2010/1/26
- Sensor-Surface: 2.5mm (Mechanical Surface Detection)
- Electronics: DAE3 Sn510; Calibrated: 2009/12/16
- Phantom: SAM with CRP; Type: SAM; Serial: TP-1485
- Measurement SW: DASY5, V5.2 Build 157; SEMCAD X Version 14.0 Build 57

Touch Position - Ch64/Area Scan (10x20x1): Measurement grid: $dx=10\text{mm}$, $dy=10\text{mm}$
Maximum value of SAR (measured) = 0.705 mW/g

Touch Position - Ch64/Zoom Scan (7x7x9)/Cube 0: Measurement grid: $dx=4\text{mm}$, $dy=4\text{mm}$,
 $dz=2.5\text{mm}$

Reference Value = 11.9 V/m; Power Drift = -0.137 dB

Peak SAR (extrapolated) = 1.75 W/kg

SAR(1 g) = **0.503 mW/g**; SAR(10 g) = 0.171 mW/g

Maximum value of SAR (measured) = 0.846 mW/g

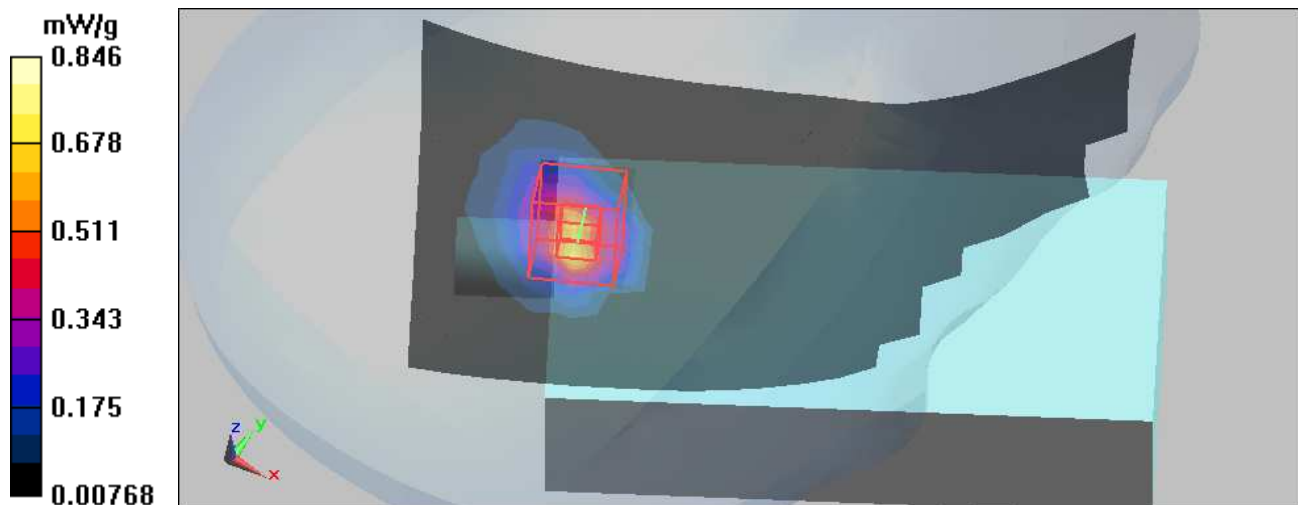

Test Laboratory: Bureau Veritas ADT

M03- A6_2D-Right Head-Cheek-11a-Ch100 / 1.5x Batt**DUT: EDA ; Type: MC 75A6**

Communication System: 802.11a ; Frequency: 5500 MHz ; Duty Cycle: 1:1

Medium: HSL5800 Medium parameters used: $f = 5500$ MHz; $\sigma = 5.02$ mho/m; $\epsilon_r = 36.3$; $\rho = 1000$ kg/m³

Phantom section: Right Section ; DUT test position : Cheek ; Modulation type: BPSK

DASY5 Configuration:

- Probe: EX3DV3 - SN3504; ConvF(4.51, 4.51, 4.51); Calibrated: 2010/1/26
- Sensor-Surface: 2.5mm (Mechanical Surface Detection)
- Electronics: DAE3 Sn510; Calibrated: 2009/12/16
- Phantom: SAM with CRP; Type: SAM; Serial: TP-1485
- Measurement SW: DASY5, V5.2 Build 157; SEMCAD X Version 14.0 Build 57

Touch Position Ch100/Area Scan (10x20x1): Measurement grid: dx=10mm, dy=10mm
Maximum value of SAR (measured) = 0.604 mW/g**Touch Position Ch100/Zoom Scan (7x7x9)/Cube 0:** Measurement grid: dx=4mm, dy=4mm, dz=2.5mm

Reference Value = 7.1 V/m; Power Drift = -0.059 dB

Peak SAR (extrapolated) = 1.42 W/kg

SAR(1 g) = 0.379 mW/g; SAR(10 g) = 0.131 mW/g

Maximum value of SAR (measured) = 0.664 mW/g

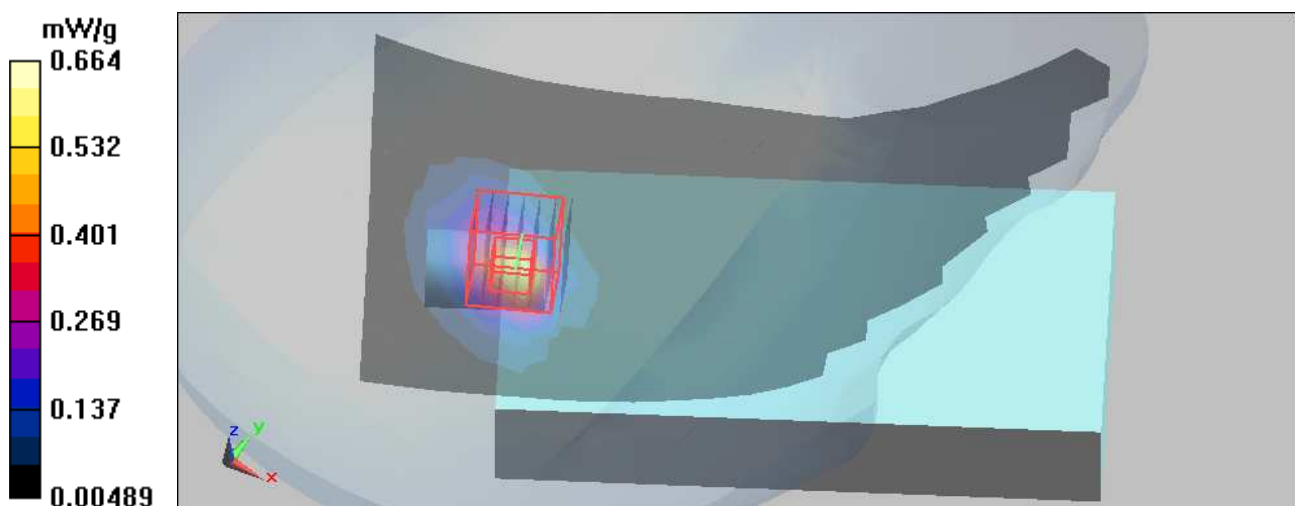

Test Laboratory: Bureau Veritas ADT

M04- A6_2D-Right Head-Cheek-11a-Ch104 / 1.5x Batt

DUT: EDA ; Type: MC 75A6

Communication System: 802.11a ; Frequency: 5520 MHz ; Duty Cycle: 1:1

Medium: HSL5800 Medium parameters used: $f = 5520 \text{ MHz}$; $\sigma = 5.04 \text{ mho/m}$; $\epsilon_r = 36.3$; $\rho = 1000 \text{ kg/m}^3$

Phantom section: Right Section ; DUT test position : Cheek ; Modulation type: BPSK

DASY5 Configuration:

- Probe: EX3DV3 - SN3504; ConvF(4.51, 4.51, 4.51); Calibrated: 2010/1/26
- Sensor-Surface: 2.5mm (Mechanical Surface Detection)
- Electronics: DAE3 Sn510; Calibrated: 2009/12/16
- Phantom: SAM with CRP; Type: SAM; Serial: TP-1485
- Measurement SW: DASY5, V5.2 Build 157; SEMCAD X Version 14.0 Build 57

Touch Position Ch104/Area Scan (10x20x1): Measurement grid: $dx=10\text{mm}$, $dy=10\text{mm}$
 Maximum value of SAR (measured) = 0.547 mW/g

Touch Position Ch104/Zoom Scan (7x7x9)/Cube 0: Measurement grid: $dx=4\text{mm}$, $dy=4\text{mm}$,
 $dz=2.5\text{mm}$

Reference Value = 6.7 V/m; Power Drift = 0.102 dB

Peak SAR (extrapolated) = 1.23 W/kg

SAR(1 g) = 0.338 mW/g; SAR(10 g) = 0.116 mW/g

Maximum value of SAR (measured) = 0.592 mW/g

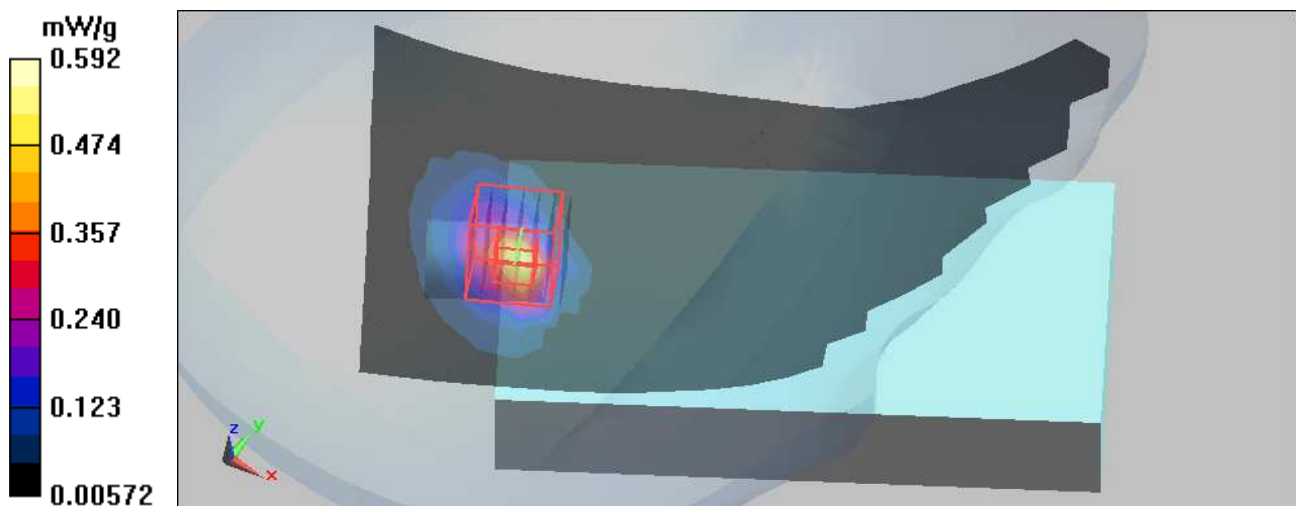

Test Laboratory: Bureau Veritas ADT

M05- A6_2D-Right Head-Cheek-11a-Ch116 / 1.5x Batt

DUT: EDA ; Type: MC 75A6

Communication System: 802.11a ; Frequency: 5580 MHz ; Duty Cycle: 1:1

Medium: HSL5800 Medium parameters used: $f = 5580 \text{ MHz}$; $\sigma = 5.12 \text{ mho/m}$; $\epsilon_r = 36.1$; $\rho = 1000 \text{ kg/m}^3$

Phantom section: Right Section ; DUT test position : Cheek ; Modulation type: BPSK

DASY5 Configuration:

- Probe: EX3DV3 - SN3504; ConvF(4.25, 4.25, 4.25); Calibrated: 2010/1/26
- Sensor-Surface: 2.5mm (Mechanical Surface Detection)
- Electronics: DAE3 Sn510; Calibrated: 2009/12/16
- Phantom: SAM with CRP; Type: SAM; Serial: TP-1485
- Measurement SW: DASY5, V5.2 Build 157; SEMCAD X Version 14.0 Build 57

Touch Position Ch116/Area Scan (10x20x1): Measurement grid: $dx=10\text{mm}$, $dy=10\text{mm}$
 Maximum value of SAR (measured) = 0.578 mW/g

Touch Position Ch116/Zoom Scan (7x7x9)/Cube 0: Measurement grid: $dx=4\text{mm}$, $dy=4\text{mm}$, $dz=2.5\text{mm}$

Reference Value = 6.86 V/m; Power Drift = 0.063 dB

Peak SAR (extrapolated) = 1.39 W/kg

SAR(1 g) = 0.370 mW/g; SAR(10 g) = 0.126 mW/g

Maximum value of SAR (measured) = 0.643 mW/g

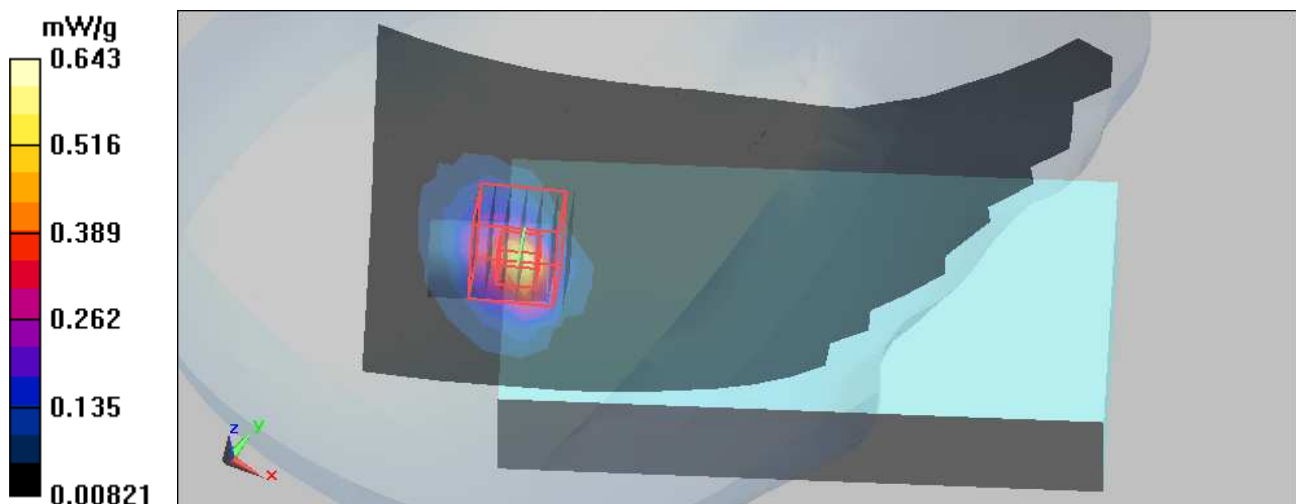

Test Laboratory: Bureau Veritas ADT

M06- A6_2D-Right Head-Cheek-11a-Ch120 / 1.5x Batt

DUT: EDA ; Type: MC 75A6

Communication System: 802.11a ; Frequency: 5600 MHz ; Duty Cycle: 1:1

Medium: HSL5800 Medium parameters used: $f = 5600 \text{ MHz}$; $\sigma = 5.14 \text{ mho/m}$; $\epsilon_r = 36.1$; $\rho = 1000 \text{ kg/m}^3$

Phantom section: Right Section ; DUT test position : Cheek ; Modulation type: BPSK

DASY5 Configuration:

- Probe: EX3DV3 - SN3504; ConvF(4.25, 4.25, 4.25); Calibrated: 2010/1/26
- Sensor-Surface: 2.5mm (Mechanical Surface Detection)
- Electronics: DAE3 Sn510; Calibrated: 2009/12/16
- Phantom: SAM with CRP; Type: SAM; Serial: TP-1485
- Measurement SW: DASY5, V5.2 Build 157; SEMCAD X Version 14.0 Build 57

Touch Position Ch120/Area Scan (10x20x1): Measurement grid: $dx=10\text{mm}$, $dy=10\text{mm}$
 Maximum value of SAR (measured) = 0.610 mW/g

Touch Position Ch120/Zoom Scan (7x7x9)/Cube 0: Measurement grid: $dx=4\text{mm}$, $dy=4\text{mm}$, $dz=2.5\text{mm}$

Reference Value = 7.16 V/m; Power Drift = 0.054 dB

Peak SAR (extrapolated) = 1.47 W/kg

SAR(1 g) = 0.395 mW/g; SAR(10 g) = 0.135 mW/g

Maximum value of SAR (measured) = 0.681 mW/g

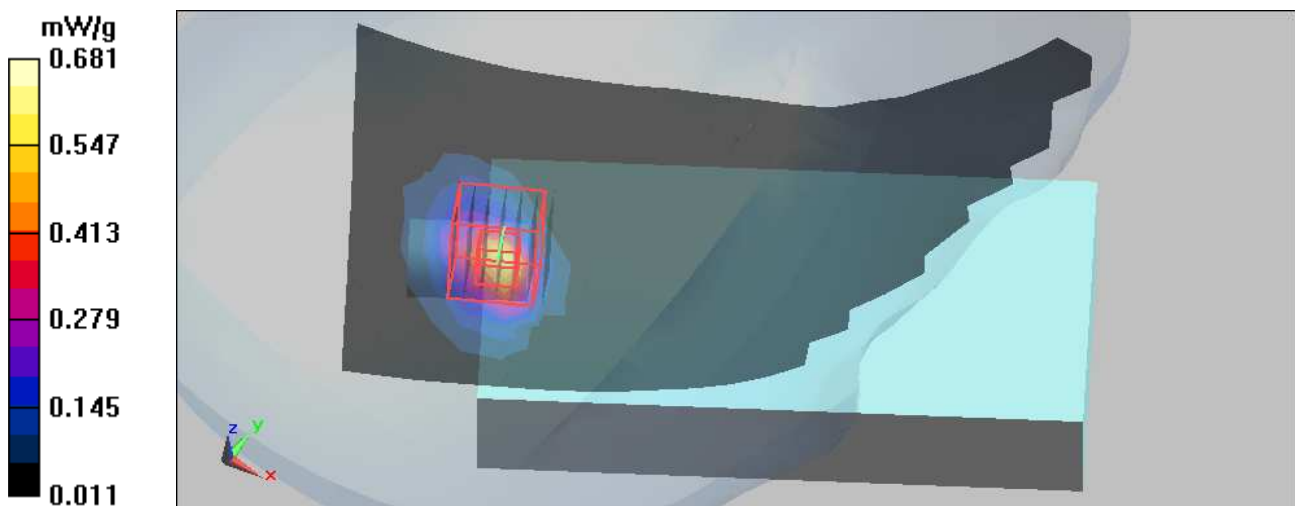

Test Laboratory: Bureau Veritas ADT

M07- A6_2D-Right Head-Cheek-11a-Ch124 / 1.5x Batt

DUT: EDA ; Type: MC 75A6

Communication System: 802.11a ; Frequency: 5620 MHz ; Duty Cycle: 1:1

Medium: HSL5800 Medium parameters used: $f = 5620 \text{ MHz}$; $\sigma = 5.17 \text{ mho/m}$; $\epsilon_r = 36.1$; $\rho = 1000 \text{ kg/m}^3$

Phantom section: Right Section ; DUT test position : Cheek ; Modulation type: BPSK

DASY5 Configuration:

- Probe: EX3DV3 - SN3504; ConvF(4.25, 4.25, 4.25); Calibrated: 2010/1/26
- Sensor-Surface: 2.5mm (Mechanical Surface Detection)
- Electronics: DAE3 Sn510; Calibrated: 2009/12/16
- Phantom: SAM with CRP; Type: SAM; Serial: TP-1485
- Measurement SW: DASY5, V5.2 Build 157; SEMCAD X Version 14.0 Build 57

Touch Position Ch124/Area Scan (10x20x1): Measurement grid: $dx=10\text{mm}$, $dy=10\text{mm}$
 Maximum value of SAR (measured) = 0.716 mW/g

Touch Position Ch124/Zoom Scan (7x7x9)/Cube 0: Measurement grid: $dx=4\text{mm}$, $dy=4\text{mm}$, $dz=2.5\text{mm}$

Reference Value = 7.67 V/m; Power Drift = 0.157 dB

Peak SAR (extrapolated) = 1.68 W/kg

SAR(1 g) = 0.456 mW/g; SAR(10 g) = 0.154 mW/g

Maximum value of SAR (measured) = 0.801 mW/g

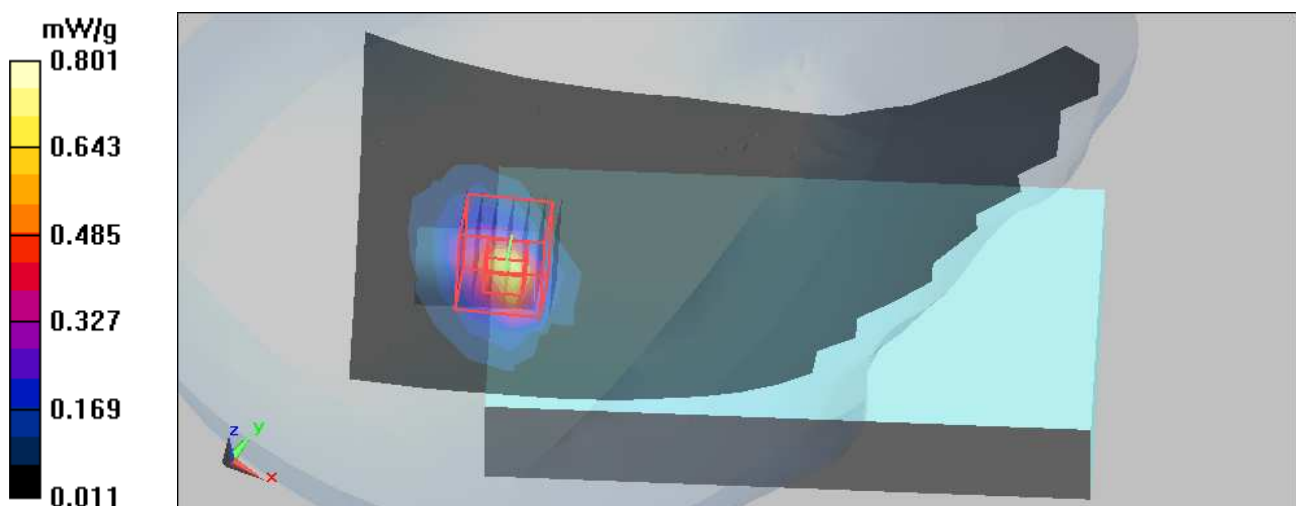

Test Laboratory: Bureau Veritas ADT

M08-A6_2D-Right Head-Cheek-11a-Ch136 / 1.5x Batt

DUT: EDA ; Type: MC75A6

Communication System: WiFi ; Frequency: 5680 MHz ; Duty Cycle: 1:1

Medium: HSL5800 Medium parameters used: $f = 5680$ MHz; $\sigma = 5.24$ mho/m; $\epsilon_r = 36.1$; $\rho = 1000$ kg/m³

Phantom section: Right Section ; DUT test position : Cheek ; Modulation type: BPSK

DASY5 Configuration:

- Probe: EX3DV3 - SN3504; ConvF(4.25, 4.25, 4.25); Calibrated: 2010/1/26
- Sensor-Surface: 2.5mm (Mechanical Surface Detection)
- Electronics: DAE3 Sn510; Calibrated: 2009/12/16
- Phantom: SAM with CRP; Type: SAM; Serial: TP-1485
- Measurement SW: DASY5, V5.2 Build 157; SEMCAD X Version 14.0 Build 57

Touch Position - Ch136/Area Scan (10x20x1): Measurement grid: dx=10mm, dy=10mm

Maximum value of SAR (measured) = 0.531 mW/g

Touch Position - Ch136/Zoom Scan (7x7x9)/Cube 0: Measurement grid: dx=4mm, dy=4mm, dz=2.5mm

Reference Value = 10.2 V/m; Power Drift = 0.032 dB

Peak SAR (extrapolated) = 1.42 W/kg

SAR(1 g) = **0.390 mW/g**; SAR(10 g) = 0.132 mW/g

Maximum value of SAR (measured) = 0.674 mW/g

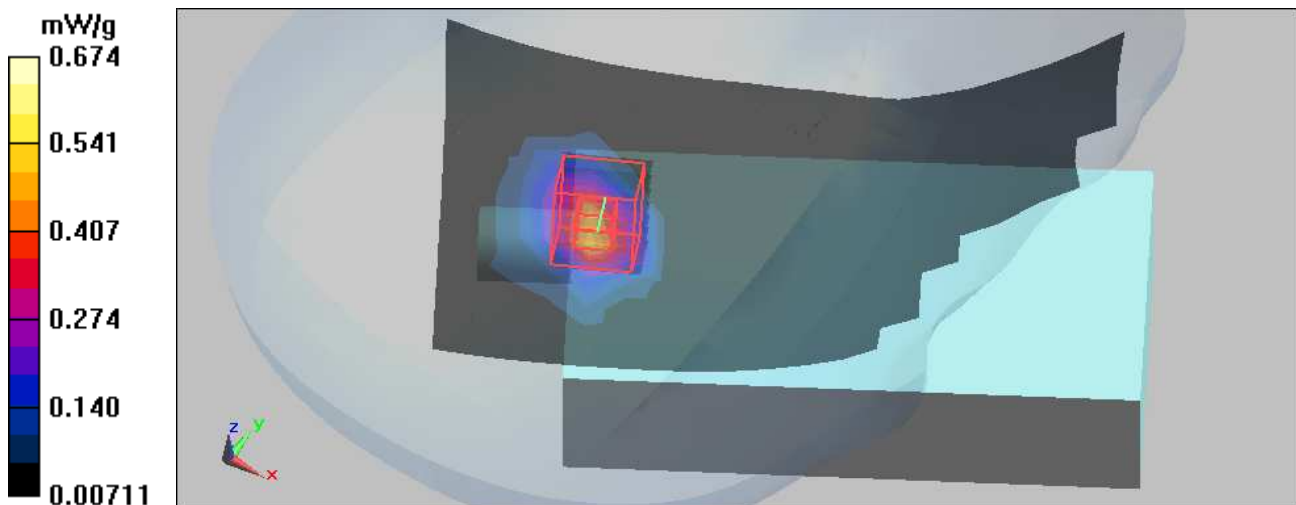

Test Laboratory: Bureau Veritas ADT

M09- A6_2D-Right Head-Cheek-11a-Ch140 / 1.5x Batt

DUT: EDA ; Type: MC 75A6

Communication System: 802.11a ; Frequency: 5700 MHz ; Duty Cycle: 1:1

Medium: HSL5800 Medium parameters used: $f = 5700$ MHz; $\sigma = 5.26$ mho/m; $\epsilon_r = 35.9$; $\rho = 1000$ kg/m³

Phantom section: Right Section ; DUT test position : Cheek ; Modulation type: BPSK

DASY5 Configuration:

- Probe: EX3DV3 - SN3504; ConvF(4.25, 4.25, 4.25); Calibrated: 2010/1/26
- Sensor-Surface: 2.5mm (Mechanical Surface Detection)
- Electronics: DAE3 Sn510; Calibrated: 2009/12/16
- Phantom: SAM with CRP; Type: SAM; Serial: TP-1485
- Measurement SW: DASY5, V5.2 Build 157; SEMCAD X Version 14.0 Build 57

Touch Position Ch140/Area Scan (10x20x1): Measurement grid: dx=10mm, dy=10mm
Maximum value of SAR (measured) = 0.480 mW/g

Touch Position Ch140/Zoom Scan (7x7x9)/Cube 0: Measurement grid: dx=4mm, dy=4mm, dz=2.5mm

Reference Value = 6.14 V/m; Power Drift = 0.101 dB

Peak SAR (extrapolated) = 1.15 W/kg

SAR(1 g) = 0.299 mW/g; SAR(10 g) = 0.104 mW/g

Maximum value of SAR (measured) = 0.520 mW/g

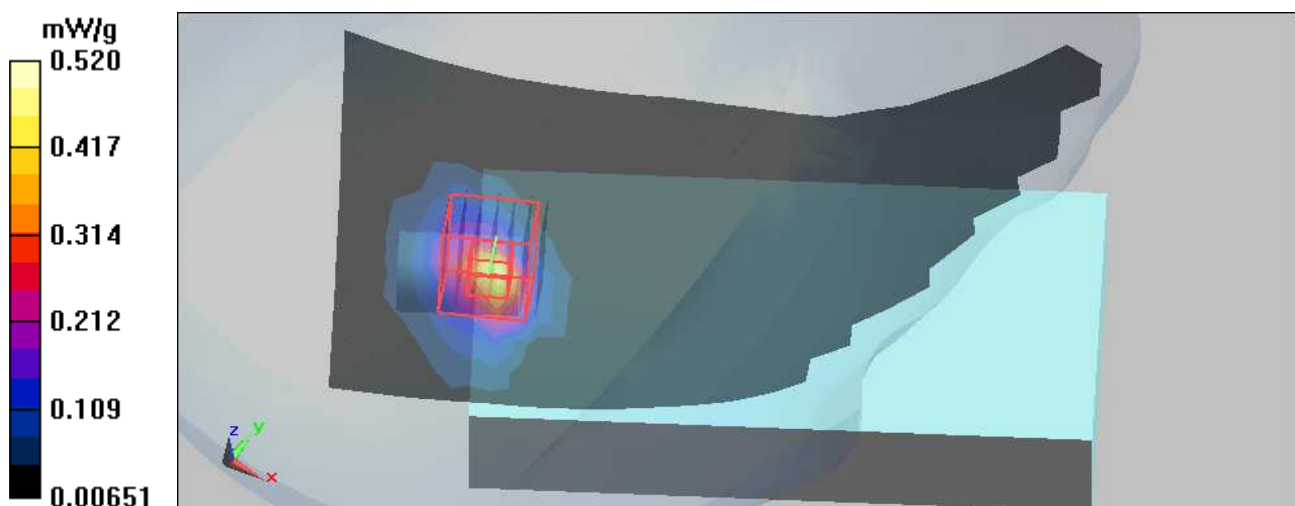

Test Laboratory: Bureau Veritas ADT

M10-A6_2D-Right Head-Tilt-11a-Ch40 / 1.5x Batt

DUT: EDA ; Type: MC75A6

Communication System: WiFi ; Frequency: 5200 MHz ; Duty Cycle: 1:1

Medium: HSL5800 Medium parameters used: $f = 5200$ MHz; $\sigma = 4.66$ mho/m; $\epsilon_r = 36.9$; $\rho = 1000$ kg/m³

Phantom section: Right Section ; DUT test position : Tilt ; Modulation type: BPSK

DASY5 Configuration:

- Probe: EX3DV3 - SN3504; ConvF(4.87, 4.87, 4.87); Calibrated: 2010/1/26
- Sensor-Surface: 2.5mm (Mechanical Surface Detection)
- Electronics: DAE3 Sn510; Calibrated: 2009/12/16
- Phantom: SAM with CRP; Type: SAM; Serial: TP-1485
- Measurement SW: DASY5, V5.2 Build 157; SEMCAD X Version 14.0 Build 57

Tilt Position - Ch40/Area Scan (10x20x1): Measurement grid: dx=10mm, dy=10mm
Maximum value of SAR (measured) = 0.358 mW/g

Tilt Position - Ch40/Zoom Scan (7x7x9)/Cube 0: Measurement grid: dx=4mm, dy=4mm, dz=2.5mm

Reference Value = 7.74 V/m; Power Drift = 0.153 dB

Peak SAR (extrapolated) = 0.857 W/kg

SAR(1 g) = **0.262** mW/g; SAR(10 g) = 0.092 mW/g

Maximum value of SAR (measured) = 0.438 mW/g

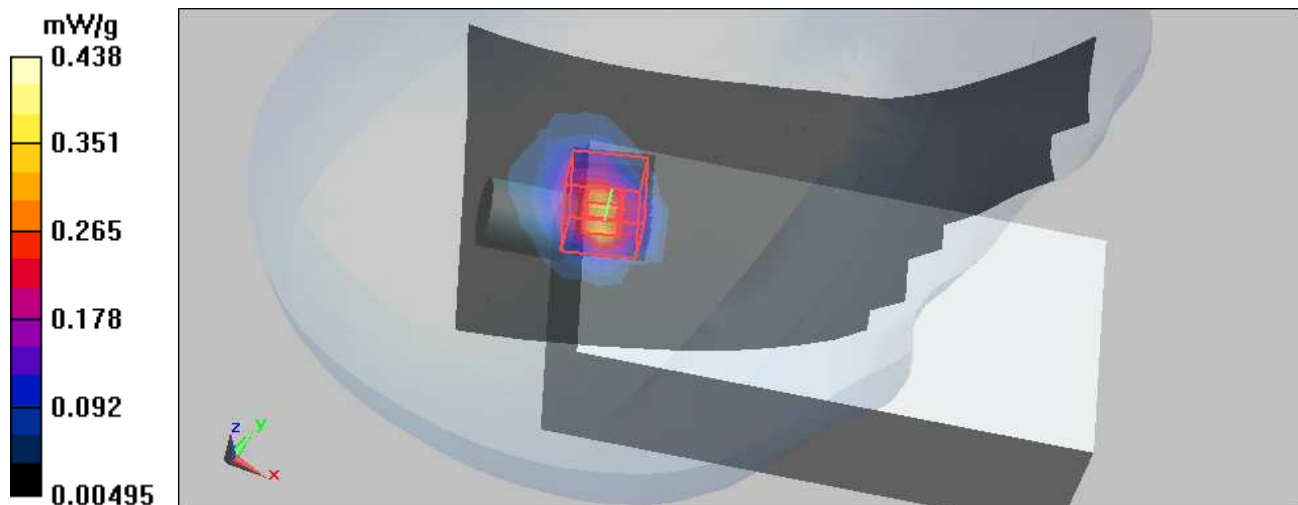

Test Laboratory: Bureau Veritas ADT

M11-A6_2D-Right Head-Tilt-11a-Ch64 / 1.5x Batt

DUT: EDA ; Type: MC75A6

Communication System: WiFi ; Frequency: 5320 MHz ; Duty Cycle: 1:1

Medium: HSL5800 Medium parameters used: $f = 5320 \text{ MHz}$; $\sigma = 4.8 \text{ mho/m}$; $\epsilon_r = 36.7$; $\rho = 1000 \text{ kg/m}^3$

Phantom section: Right Section ; DUT test position : Cheek ; Modulation type: BPSK

DASY5 Configuration:

- Probe: EX3DV3 - SN3504; ConvF(4.62, 4.62, 4.62); Calibrated: 2010/1/26
- Sensor-Surface: 2.5mm (Mechanical Surface Detection)
- Electronics: DAE3 Sn510; Calibrated: 2009/12/16
- Phantom: SAM with CRP; Type: SAM; Serial: TP-1485
- Measurement SW: DASY5, V5.2 Build 157; SEMCAD X Version 14.0 Build 57

Tilt Position - Ch64 2.5X/Area Scan (10x20x1): Measurement grid: $dx=10\text{mm}$, $dy=10\text{mm}$
 Maximum value of SAR (measured) = 0.741 mW/g

Tilt Position - Ch64 2.5X/Zoom Scan (7x7x9)/Cube 0: Measurement grid: $dx=4\text{mm}$, $dy=4\text{mm}$,
 $dz=2.5\text{mm}$

Reference Value = 9.08 V/m; Power Drift = 0.032 dB

Peak SAR (extrapolated) = 1.87 W/kg

SAR(1 g) = **0.542 mW/g**; SAR(10 g) = **0.181 mW/g**

Maximum value of SAR (measured) = 0.890 mW/g

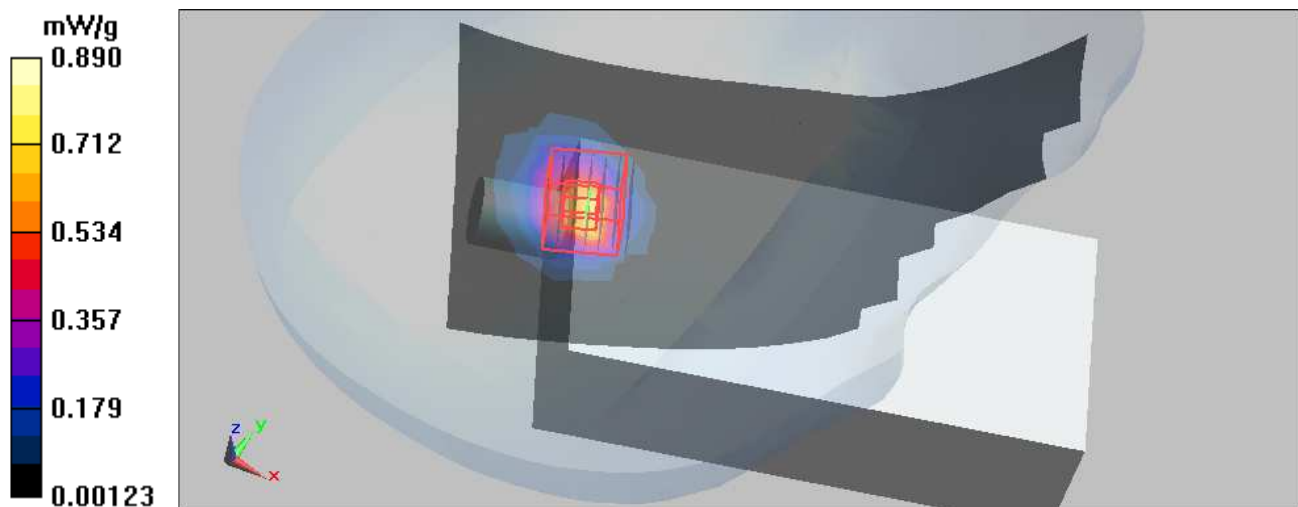

Test Laboratory: Bureau Veritas ADT

M12- A6_2D-Right Head-Tilt-11a-Ch100 / 1.5x Batt

DUT: EDA ; Type: MC 75A6

Communication System: 802.11a ; Frequency: 5500 MHz ; Duty Cycle: 1:1

Medium: HSL5800 Medium parameters used: $f = 5500 \text{ MHz}$; $\sigma = 5.02 \text{ mho/m}$; $\epsilon_r = 36.3$; $\rho = 1000 \text{ kg/m}^3$

Phantom section: Right Section ; DUT test position : Cheek ; Modulation type: BPSK

DASY5 Configuration:

- Probe: EX3DV3 - SN3504; ConvF(4.51, 4.51, 4.51); Calibrated: 2010/1/26
- Sensor-Surface: 2.5mm (Mechanical Surface Detection)
- Electronics: DAE3 Sn510; Calibrated: 2009/12/16
- Phantom: SAM with CRP; Type: SAM; Serial: TP-1485
- Measurement SW: DASY5, V5.2 Build 157; SEMCAD X Version 14.0 Build 57

Tilt Position Ch100/Area Scan (10x20x1): Measurement grid: $dx=10\text{mm}$, $dy=10\text{mm}$
 Maximum value of SAR (measured) = 0.547 mW/g

Tilt Position Ch100/Zoom Scan (7x7x9)/Cube 0: Measurement grid: $dx=4\text{mm}$, $dy=4\text{mm}$,
 $dz=2.5\text{mm}$

Reference Value = 6.05 V/m; Power Drift = 0.192 dB

Peak SAR (extrapolated) = 1.43 W/kg

SAR(1 g) = 0.392 mW/g; SAR(10 g) = 0.126 mW/g

Maximum value of SAR (measured) = 0.692 mW/g

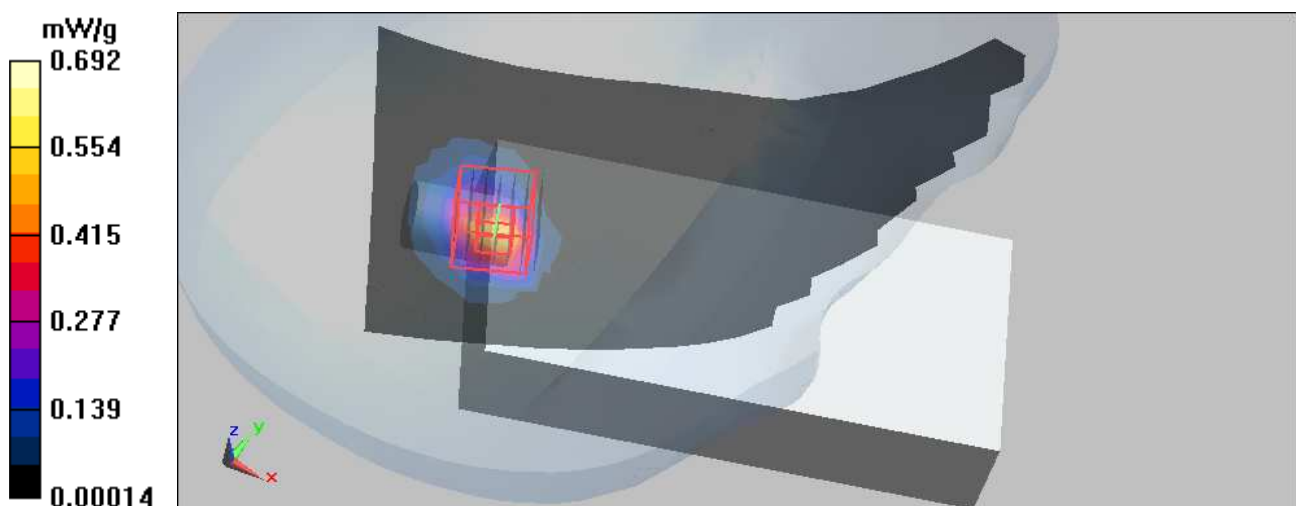

Test Laboratory: Bureau Veritas ADT

M13- A6_2D-Right Head-Tilt-11a-Ch104 / 1.5x Batt

DUT: EDA ; Type: MC 75A6

Communication System: 802.11a ; Frequency: 5520 MHz ; Duty Cycle: 1:1

Medium: HSL5800 Medium parameters used: $f = 5520$ MHz; $\sigma = 5.04$ mho/m; $\epsilon_r = 36.3$; $\rho = 1000$ kg/m³

Phantom section: Right Section ; DUT test position : Cheek ; Modulation type: BPSK

DASY5 Configuration:

- Probe: EX3DV3 - SN3504; ConvF(4.51, 4.51, 4.51); Calibrated: 2010/1/26
- Sensor-Surface: 2.5mm (Mechanical Surface Detection)
- Electronics: DAE3 Sn510; Calibrated: 2009/12/16
- Phantom: SAM with CRP; Type: SAM; Serial: TP-1485
- Measurement SW: DASY5, V5.2 Build 157; SEMCAD X Version 14.0 Build 57

Tilt Position Ch104/Area Scan (10x20x1): Measurement grid: dx=10mm, dy=10mm
Maximum value of SAR (measured) = 0.491 mW/g

Tilt Position Ch104/Zoom Scan (7x7x9)/Cube 0: Measurement grid: dx=4mm, dy=4mm, dz=2.5mm

Reference Value = 5.66 V/m; Power Drift = 0.096 dB

Peak SAR (extrapolated) = 1.33 W/kg

SAR(1 g) = 0.348 mW/g; SAR(10 g) = 0.111 mW/g

Maximum value of SAR (measured) = 0.606 mW/g

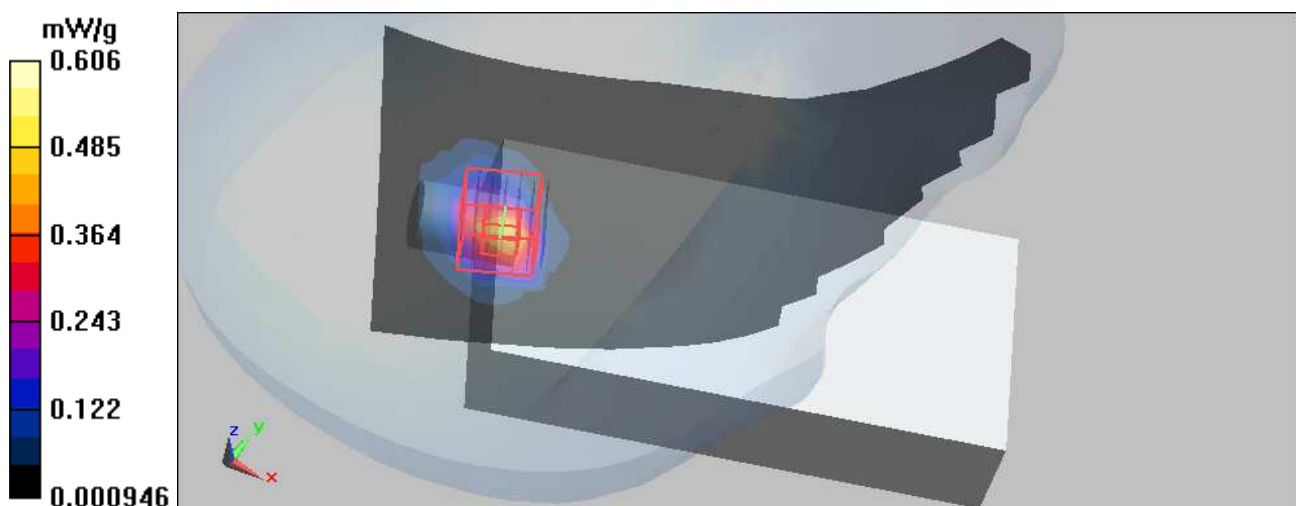

Test Laboratory: Bureau Veritas ADT

M14- A6_2D-Right Head-Tilt-11a-Ch116 / 1.5x Batt

DUT: EDA ; Type: MC 75A6

Communication System: 802.11a ; Frequency: 5580 MHz ; Duty Cycle: 1:1

Medium: HSL5800 Medium parameters used: $f = 5580 \text{ MHz}$; $\sigma = 5.12 \text{ mho/m}$; $\epsilon_r = 36.1$; $\rho = 1000 \text{ kg/m}^3$

Phantom section: Right Section ; DUT test position : Cheek ; Modulation type: BPSK

DASY5 Configuration:

- Probe: EX3DV3 - SN3504; ConvF(4.25, 4.25, 4.25); Calibrated: 2010/1/26
- Sensor-Surface: 2.5mm (Mechanical Surface Detection)
- Electronics: DAE3 Sn510; Calibrated: 2009/12/16
- Phantom: SAM with CRP; Type: SAM; Serial: TP-1485
- Measurement SW: DASY5, V5.2 Build 157; SEMCAD X Version 14.0 Build 57

Tilt Position Ch116/Area Scan (10x20x1): Measurement grid: $dx=10\text{mm}$, $dy=10\text{mm}$
 Maximum value of SAR (measured) = 0.555 mW/g

Tilt Position Ch116/Zoom Scan (7x7x9)/Cube 0: Measurement grid: $dx=4\text{mm}$, $dy=4\text{mm}$, $dz=2.5\text{mm}$

Reference Value = 5.91 V/m; Power Drift = 0.183 dB

Peak SAR (extrapolated) = 1.42 W/kg

SAR(1 g) = 0.382 mW/g; SAR(10 g) = 0.122 mW/g

Maximum value of SAR (measured) = 0.689 mW/g

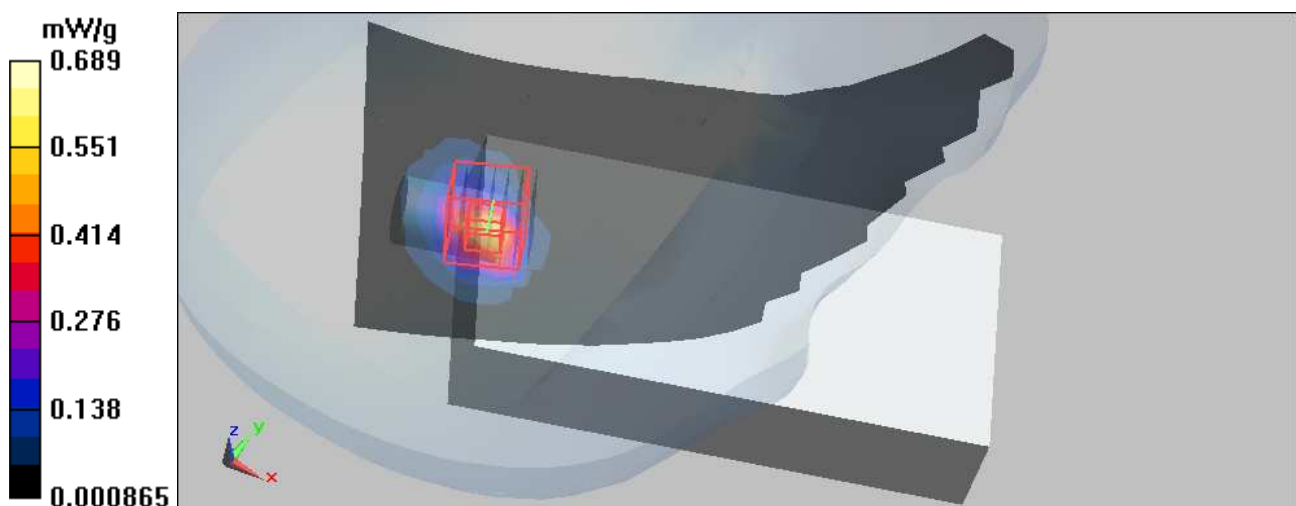

Test Laboratory: Bureau Veritas ADT

M15- A6_2D-Right Head-Tilt-11a-Ch120 / 1.5x Batt

DUT: EDA ; Type: MC 75A6

Communication System: 802.11a ; Frequency: 5600 MHz ; Duty Cycle: 1:1

Medium: HSL5800 Medium parameters used: $f = 5600 \text{ MHz}$; $\sigma = 5.14 \text{ mho/m}$; $\epsilon_r = 36.1$; $\rho = 1000 \text{ kg/m}^3$

Phantom section: Right Section ; DUT test position : Cheek ; Modulation type: BPSK

DASY5 Configuration:

- Probe: EX3DV3 - SN3504; ConvF(4.25, 4.25, 4.25); Calibrated: 2010/1/26
- Sensor-Surface: 2.5mm (Mechanical Surface Detection)
- Electronics: DAE3 Sn510; Calibrated: 2009/12/16
- Phantom: SAM with CRP; Type: SAM; Serial: TP-1485
- Measurement SW: DASY5, V5.2 Build 157; SEMCAD X Version 14.0 Build 57

Tilt Position Ch120/Area Scan (10x20x1): Measurement grid: $dx=10\text{mm}$, $dy=10\text{mm}$
 Maximum value of SAR (measured) = 0.581 mW/g

Tilt Position Ch120/Zoom Scan (7x7x9)/Cube 0: Measurement grid: $dx=4\text{mm}$, $dy=4\text{mm}$, $dz=2.5\text{mm}$

Reference Value = 6.16 V/m; Power Drift = 0.065 dB

Peak SAR (extrapolated) = 1.47 W/kg

SAR(1 g) = 0.399 mW/g; SAR(10 g) = 0.129 mW/g

Maximum value of SAR (measured) = 0.692 mW/g

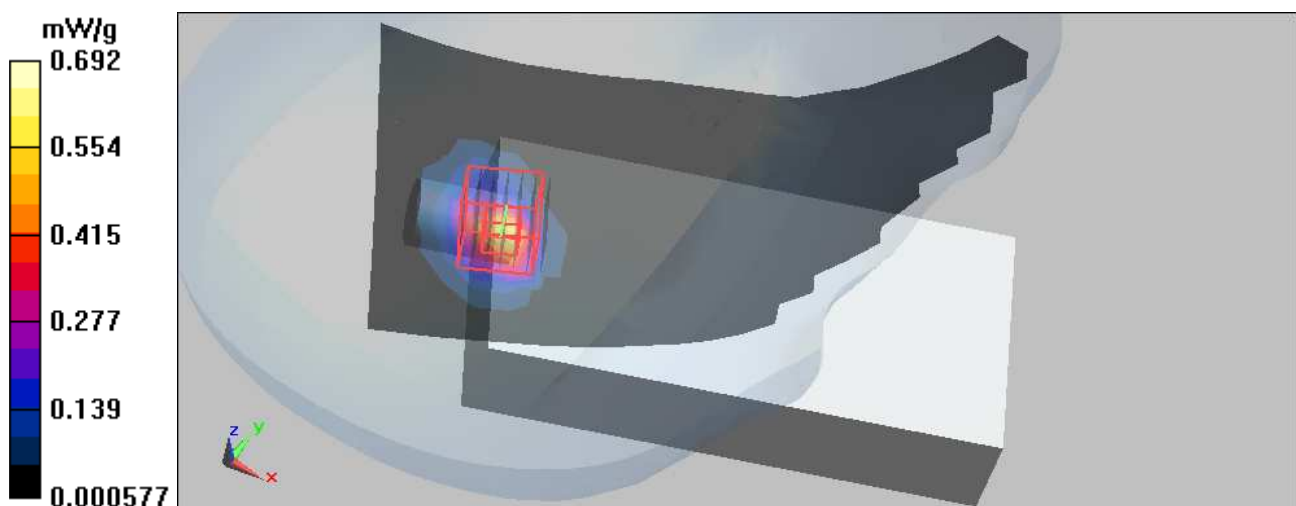

Test Laboratory: Bureau Veritas ADT

M16- A6_2D-Right Head-Tilt-11a-Ch124 / 1.5x Batt

DUT: EDA ; Type: MC 75A6

Communication System: 802.11a ; Frequency: 5620 MHz ; Duty Cycle: 1:1

Medium: HSL5800 Medium parameters used: $f = 5620$ MHz; $\sigma = 5.17$ mho/m; $\epsilon_r = 36.1$; $\rho = 1000$ kg/m³

Phantom section: Right Section ; DUT test position : Cheek ; Modulation type: BPSK

DASY5 Configuration:

- Probe: EX3DV3 - SN3504; ConvF(4.25, 4.25, 4.25); Calibrated: 2010/1/26
- Sensor-Surface: 2.5mm (Mechanical Surface Detection)
- Electronics: DAE3 Sn510; Calibrated: 2009/12/16
- Phantom: SAM with CRP; Type: SAM; Serial: TP-1485
- Measurement SW: DASY5, V5.2 Build 157; SEMCAD X Version 14.0 Build 57

Tilt Position Ch124/Area Scan (10x20x1): Measurement grid: dx=10mm, dy=10mm
Maximum value of SAR (measured) = 0.667 mW/g

Tilt Position Ch124/Zoom Scan (7x7x9)/Cube 0: Measurement grid: dx=4mm, dy=4mm, dz=2.5mm

Reference Value = 6.76 V/m; Power Drift = 0.066 dB

Peak SAR (extrapolated) = 1.7 W/kg

SAR(1 g) = 0.460 mW/g; SAR(10 g) = 0.146 mW/g

Maximum value of SAR (measured) = 0.823 mW/g

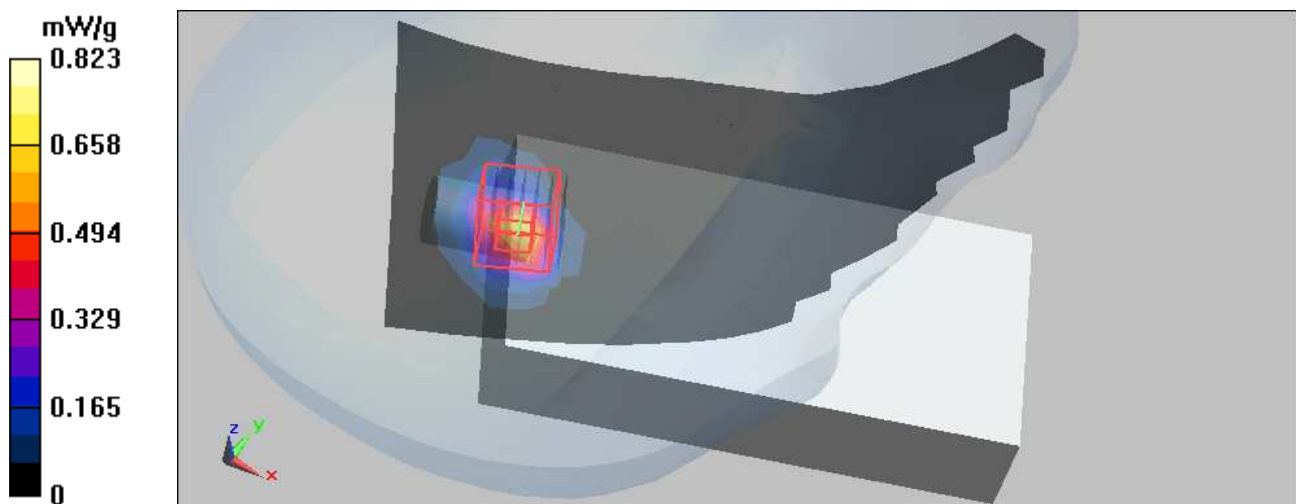

Test Laboratory: Bureau Veritas ADT

M17-A6_2D-Right Head-Tilt-11a-Ch136 / 1.5x Batt

DUT: EDA ; Type: MC75A6

Communication System: WiFi ; Frequency: 5680 MHz ; Duty Cycle: 1:1

Medium: HSL5800 Medium parameters used: $f = 5680 \text{ MHz}$; $\sigma = 5.24 \text{ mho/m}$; $\epsilon_r = 36.1$; $\rho = 1000 \text{ kg/m}^3$

Phantom section: Right Section ; DUT test position : Cheek ; Modulation type: BPSK

DASY5 Configuration:

- Probe: EX3DV3 - SN3504; ConvF(4.25, 4.25, 4.25); Calibrated: 2010/1/26
- Sensor-Surface: 2.5mm (Mechanical Surface Detection)
- Electronics: DAE3 Sn510; Calibrated: 2009/12/16
- Phantom: SAM with CRP; Type: SAM; Serial: TP-1485
- Measurement SW: DASY5, V5.2 Build 157; SEMCAD X Version 14.0 Build 57

Tilt Position - Ch136 2.5X/Area Scan (10x20x1): Measurement grid: $dx=10\text{mm}$, $dy=10\text{mm}$
 Maximum value of SAR (measured) = 0.486 mW/g

Tilt Position - Ch136 2.5X/Zoom Scan (7x7x9)/Cube 0: Measurement grid: $dx=4\text{mm}$, $dy=4\text{mm}$, $dz=2.5\text{mm}$

Reference Value = 7.35 V/m; Power Drift = 0.054 dB

Peak SAR (extrapolated) = 1.45 W/kg

SAR(1 g) = **0.383 mW/g**; SAR(10 g) = 0.125 mW/g

Maximum value of SAR (measured) = 0.652 mW/g

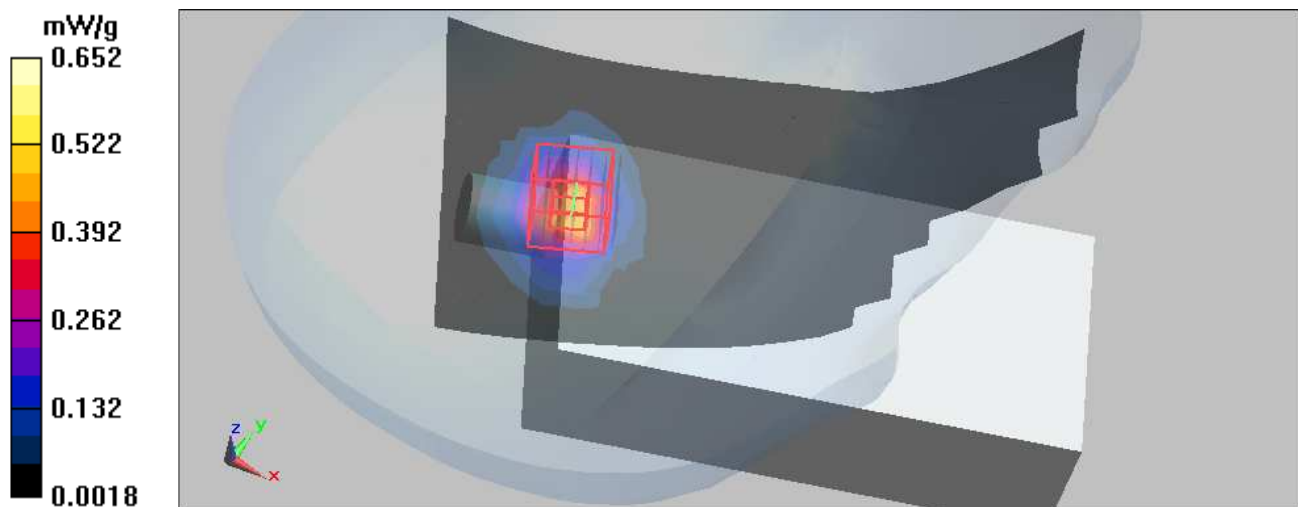

Test Laboratory: Bureau Veritas ADT

M18- A6_2D-Right Head-Tilt-11a-Ch140 / 1.5x Batt

DUT: EDA ; Type: MC 75A6

Communication System: 802.11a ; Frequency: 5700 MHz ; Duty Cycle: 1:1

Medium: HSL5800 Medium parameters used: $f = 5700 \text{ MHz}$; $\sigma = 5.26 \text{ mho/m}$; $\epsilon_r = 35.9$; $\rho = 1000 \text{ kg/m}^3$

Phantom section: Right Section ; DUT test position : Cheek ; Modulation type: BPSK

DASY5 Configuration:

- Probe: EX3DV3 - SN3504; ConvF(4.25, 4.25, 4.25); Calibrated: 2010/1/26
- Sensor-Surface: 2.5mm (Mechanical Surface Detection)
- Electronics: DAE3 Sn510; Calibrated: 2009/12/16
- Phantom: SAM with CRP; Type: SAM; Serial: TP-1485
- Measurement SW: DASY5, V5.2 Build 157; SEMCAD X Version 14.0 Build 57

Tilt Position Ch140/Area Scan (10x20x1): Measurement grid: $dx=10\text{mm}$, $dy=10\text{mm}$
 Maximum value of SAR (measured) = 0.435 mW/g

Tilt Position Ch140/Zoom Scan (7x7x9)/Cube 0: Measurement grid: $dx=4\text{mm}$, $dy=4\text{mm}$,
 $dz=2.5\text{mm}$

Reference Value = 5.42 V/m; Power Drift = 0.190 dB

Peak SAR (extrapolated) = 1.11 W/kg

SAR(1 g) = 0.295 mW/g; SAR(10 g) = 0.096 mW/g

Maximum value of SAR (measured) = 0.525 mW/g

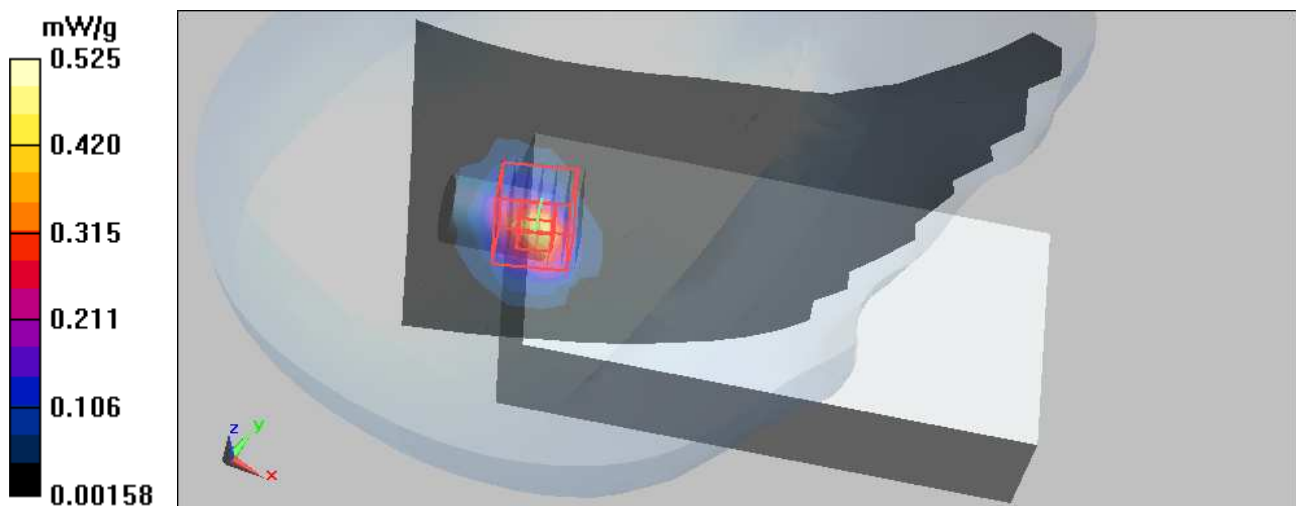

Test Laboratory: Bureau Veritas ADT

M19-A6_2D-Left Head Cheek 11a-Ch40 / 1.5x Batt

DUT: EDA ; Type: MC75A6

Communication System: WiFi ; Frequency: 5200 MHz ; Duty Cycle: 1:1

Medium: HSL5800 Medium parameters used: $f = 5200 \text{ MHz}$; $\sigma = 4.66 \text{ mho/m}$; $\epsilon_r = 36.9$; $\rho = 1000 \text{ kg/m}^3$

Phantom section: Left Section ; DUT test position : Cheek ; Modulation type: BPSK

DASY5 Configuration:

- Probe: EX3DV3 - SN3504; ConvF(4.87, 4.87, 4.87); Calibrated: 2010/1/26
- Sensor-Surface: 2.5mm (Mechanical Surface Detection)
- Electronics: DAE3 Sn510; Calibrated: 2009/12/16
- Phantom: SAM with CRP; Type: SAM; Serial: TP-1485
- Measurement SW: DASY5, V5.2 Build 157; SEMCAD X Version 14.0 Build 57

Touch Position - Ch40/Area Scan (10x20x1): Measurement grid: $dx=10\text{mm}$, $dy=10\text{mm}$

Maximum value of SAR (measured) = 0.455 mW/g

Touch Position - Ch40/Zoom Scan (7x7x9)/Cube 0: Measurement grid: $dx=4\text{mm}$, $dy=4\text{mm}$, $dz=2.5\text{mm}$

Reference Value = 8.34 V/m; Power Drift = 0.029 dB

Peak SAR (extrapolated) = 0.962 W/kg

SAR(1 g) = **0.290 mW/g**; SAR(10 g) = 0.097 mW/g

Maximum value of SAR (measured) = 0.500 mW/g

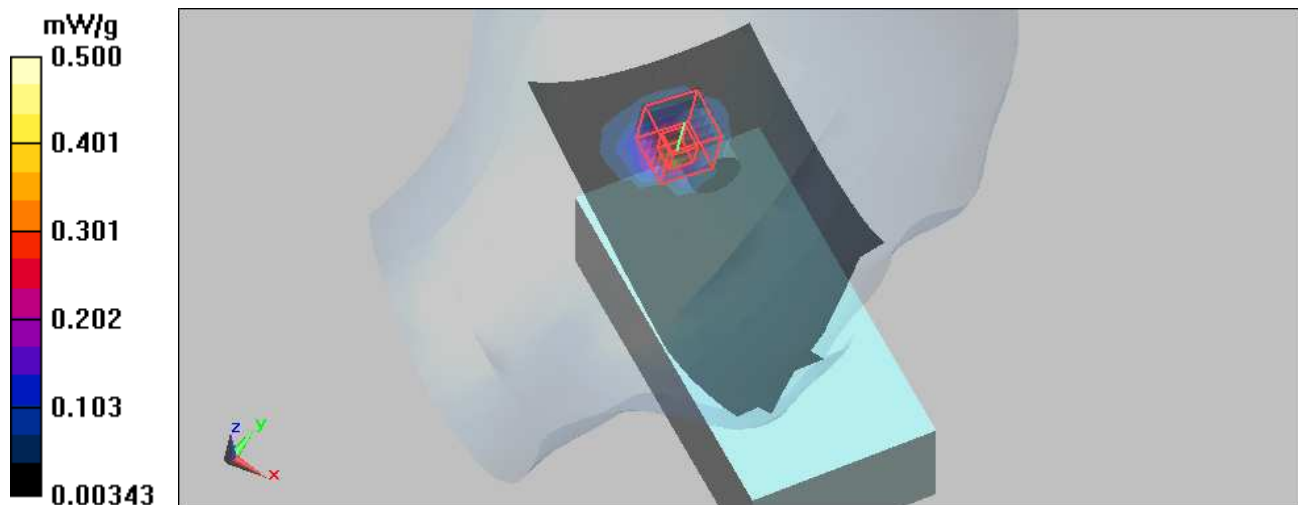

Test Laboratory: Bureau Veritas ADT

M20-A6_2D-Left Head-Cheek-11a-Ch64 / 1.5x Batt

DUT: EDA ; Type: MC75A6

Communication System: WiFi ; Frequency: 5320 MHz ; Duty Cycle: 1:1

Medium: HSL5800 Medium parameters used: $f = 5320 \text{ MHz}$; $\sigma = 4.8 \text{ mho/m}$; $\epsilon_r = 36.7$; $\rho = 1000 \text{ kg/m}^3$

Phantom section: Left Section ; DUT test position : Cheek ; Modulation type: BPSK

DASY5 Configuration:

- Probe: EX3DV3 - SN3504; ConvF(4.62, 4.62, 4.62); Calibrated: 2010/1/26
- Sensor-Surface: 2.5mm (Mechanical Surface Detection)
- Electronics: DAE3 Sn510; Calibrated: 2009/12/16
- Phantom: SAM with CRP; Type: SAM; Serial: TP-1485
- Measurement SW: DASY5, V5.2 Build 157; SEMCAD X Version 14.0 Build 57

Configuration/Touch Position - Ch64 2.5X/Area Scan (10x20x1): Measurement grid:

$dx=10\text{mm}$, $dy=10\text{mm}$

Maximum value of SAR (measured) = 0.932 mW/g

Configuration/Touch Position - Ch64 2.5X/Zoom Scan (7x7x9)/Cube 0: Measurement grid:

$dx=4\text{mm}$, $dy=4\text{mm}$, $dz=2.5\text{mm}$

Reference Value = 9.66 V/m; Power Drift = 0.157 dB

Peak SAR (extrapolated) = 1.89 W/kg

SAR(1 g) = **0.559 mW/g**; SAR(10 g) = 0.187 mW/g

Maximum value of SAR (measured) = 0.931 mW/g

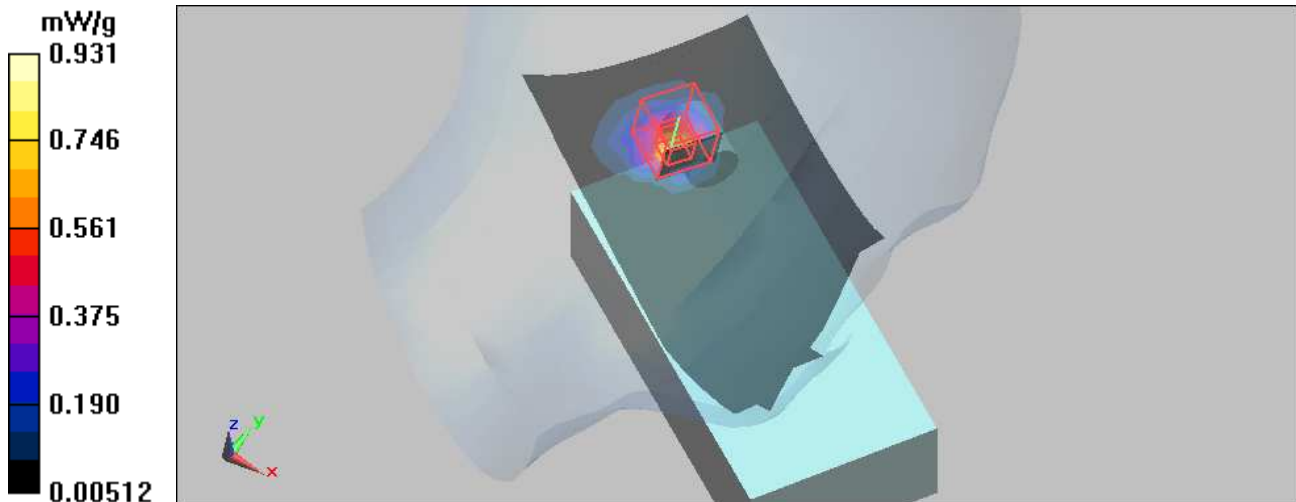

Test Laboratory: Bureau Veritas ADT

M21- A6_2D-Left Head-Cheek-11a-Ch100 / 1.5x Batt

DUT: EDA ; Type: MC 75A6

Communication System: 802.11a ; Frequency: 5500 MHz ; Duty Cycle: 1:1

Medium: HSL5800 Medium parameters used: $f = 5500 \text{ MHz}$; $\sigma = 4.96 \text{ mho/m}$; $\epsilon_r = 36.1$; $\rho = 1000 \text{ kg/m}^3$

Phantom section: Left Section ; DUT test position : Cheek ; Modulation type: BPSK

DASY5 Configuration:

- Probe: EX3DV3 - SN3504; ConvF(4.51, 4.51, 4.51); Calibrated: 2010/1/26
- Sensor-Surface: 2.5mm (Mechanical Surface Detection)
- Electronics: DAE3 Sn510; Calibrated: 2009/12/16
- Phantom: SAM with CRP; Type: SAM; Serial: TP-1485
- Measurement SW: DASY5, V5.2 Build 157; SEMCAD X Version 14.0 Build 57

Touch Position Ch100/Area Scan (10x20x1): Measurement grid: $dx=10\text{mm}$, $dy=10\text{mm}$
 Maximum value of SAR (measured) = 0.570 mW/g

Touch Position Ch100/Zoom Scan (7x7x9)/Cube 0: Measurement grid: $dx=4\text{mm}$, $dy=4\text{mm}$,
 $dz=2.5\text{mm}$

Reference Value = 8.64 V/m; Power Drift = -0.019 dB

Peak SAR (extrapolated) = 1.39 W/kg

SAR(1 g) = 0.384 mW/g; SAR(10 g) = 0.133 mW/g

Maximum value of SAR (measured) = 0.644 mW/g

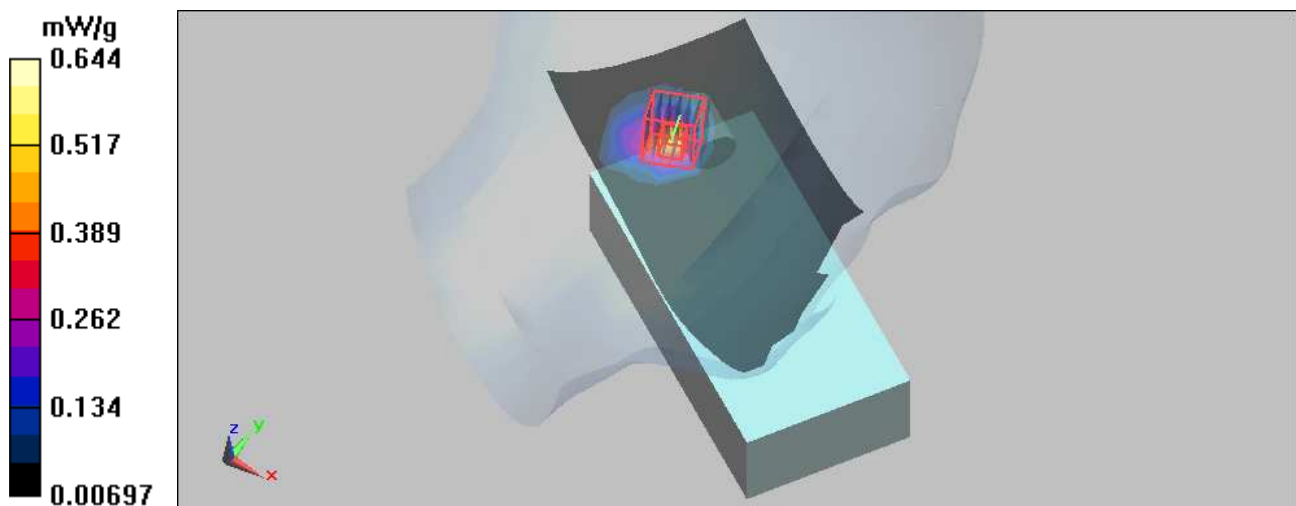

Test Laboratory: Bureau Veritas ADT

M22- A6_2D-Left Head-Cheek-11a-Ch104 / 1.5x Batt

DUT: EDA ; Type: MC 75A6

Communication System: 802.11a ; Frequency: 5520 MHz ; Duty Cycle: 1:1

Medium: HSL5800 Medium parameters used: $f = 5520 \text{ MHz}$; $\sigma = 4.98 \text{ mho/m}$; $\epsilon_r = 36$; $\rho = 1000 \text{ kg/m}^3$

Phantom section: Left Section ; DUT test position : Cheek ; Modulation type: BPSK

DASY5 Configuration:

- Probe: EX3DV3 - SN3504; ConvF(4.51, 4.51, 4.51); Calibrated: 2010/1/26
- Sensor-Surface: 2.5mm (Mechanical Surface Detection)
- Electronics: DAE3 Sn510; Calibrated: 2009/12/16
- Phantom: SAM with CRP; Type: SAM; Serial: TP-1485
- Measurement SW: DASY5, V5.2 Build 157; SEMCAD X Version 14.0 Build 57

Touch Position Ch104/Area Scan (10x20x1): Measurement grid: $dx=10\text{mm}$, $dy=10\text{mm}$
 Maximum value of SAR (measured) = 0.512 mW/g

Touch Position Ch104/Zoom Scan (7x7x9)/Cube 0: Measurement grid: $dx=4\text{mm}$, $dy=4\text{mm}$,
 $dz=2.5\text{mm}$

Reference Value = 8.21 V/m; Power Drift = 0.033 dB

Peak SAR (extrapolated) = 1.26 W/kg

SAR(1 g) = 0.363 mW/g; SAR(10 g) = 0.125 mW/g

Maximum value of SAR (measured) = 0.617 mW/g

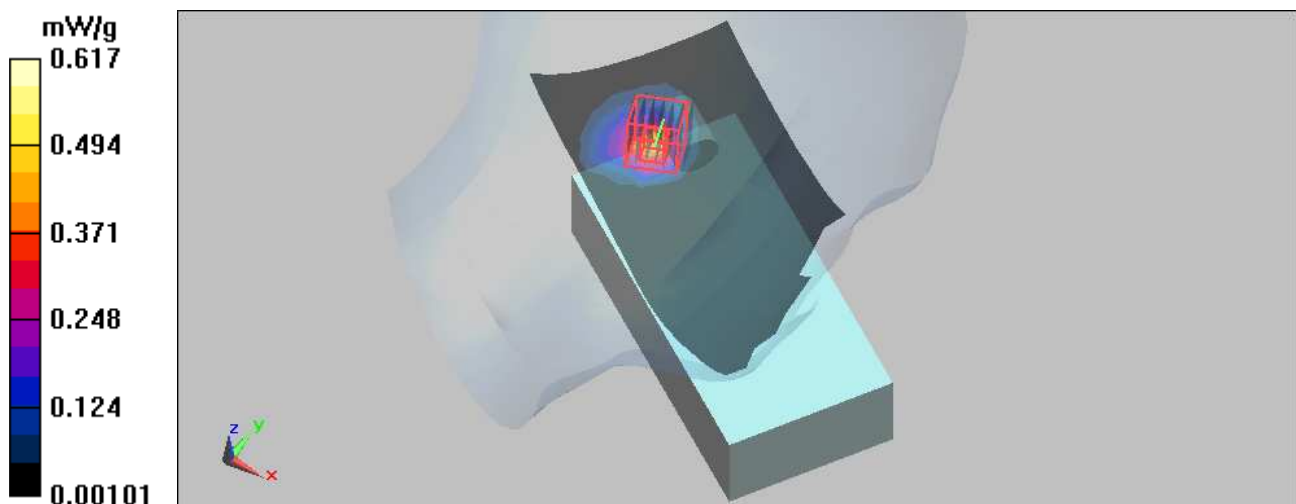

Test Laboratory: Bureau Veritas ADT

M23- A6_2D-Left Head-Cheek-11a-Ch116 / 1.5x Batt

DUT: EDA ; Type: MC 75A6

Communication System: 802.11a ; Frequency: 5580 MHz ; Duty Cycle: 1:1

Medium: HSL5800 Medium parameters used: $f = 5580 \text{ MHz}$; $\sigma = 5.06 \text{ mho/m}$; $\epsilon_r = 35.9$; $\rho = 1000 \text{ kg/m}^3$

Phantom section: Left Section ; DUT test position : Cheek ; Modulation type: BPSK

DASY5 Configuration:

- Probe: EX3DV3 - SN3504; ConvF(4.25, 4.25, 4.25); Calibrated: 2010/1/26
- Sensor-Surface: 2.5mm (Mechanical Surface Detection)
- Electronics: DAE3 Sn510; Calibrated: 2009/12/16
- Phantom: SAM with CRP; Type: SAM; Serial: TP-1485
- Measurement SW: DASY5, V5.2 Build 157; SEMCAD X Version 14.0 Build 57

Touch Position Ch116/Area Scan (10x20x1): Measurement grid: $dx=10\text{mm}$, $dy=10\text{mm}$
 Maximum value of SAR (measured) = 0.433 mW/g

Touch Position Ch116/Zoom Scan (7x7x9)/Cube 0: Measurement grid: $dx=4\text{mm}$, $dy=4\text{mm}$,
 $dz=2.5\text{mm}$

Reference Value = 7.69 V/m; Power Drift = -0.184 dB

Peak SAR (extrapolated) = 0.996 W/kg

SAR(1 g) = 0.293 mW/g; SAR(10 g) = 0.104 mW/g

Maximum value of SAR (measured) = 0.495 mW/g

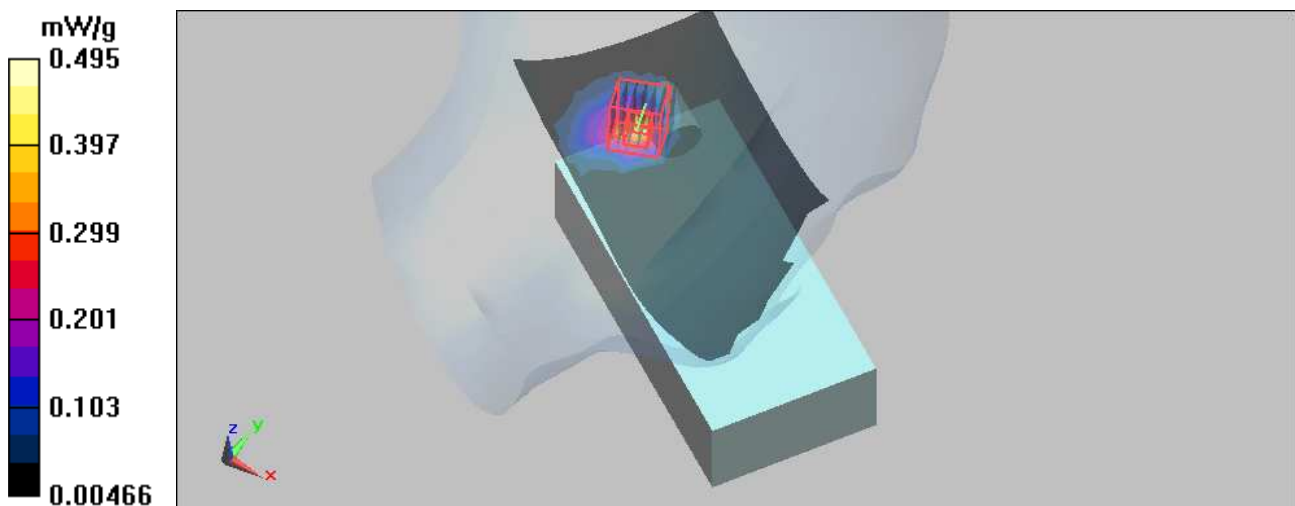

Test Laboratory: Bureau Veritas ADT

M24- A6_2D-Left Head-Cheek-11a-Ch120 / 1.5x Batt

DUT: EDA ; Type: MC 75A6

Communication System: 802.11a ; Frequency: 5600 MHz ; Duty Cycle: 1:1

Medium: HSL5800 Medium parameters used: $f = 5600$ MHz; $\sigma = 5.09$ mho/m; $\epsilon_r = 35.9$; $\rho = 1000$ kg/m³

Phantom section: Left Section ; DUT test position : Cheek ; Modulation type: BPSK

DASY5 Configuration:

- Probe: EX3DV3 - SN3504; ConvF(4.25, 4.25, 4.25); Calibrated: 2010/1/26
- Sensor-Surface: 2.5mm (Mechanical Surface Detection)
- Electronics: DAE3 Sn510; Calibrated: 2009/12/16
- Phantom: SAM with CRP; Type: SAM; Serial: TP-1485
- Measurement SW: DASY5, V5.2 Build 157; SEMCAD X Version 14.0 Build 57

Touch Position Ch120/Area Scan (10x20x1): Measurement grid: dx=10mm, dy=10mm
 Maximum value of SAR (measured) = 0.487 mW/g

Touch Position Ch120/Zoom Scan (7x7x9)/Cube 0: Measurement grid: dx=4mm, dy=4mm, dz=2.5mm

Reference Value = 7.97 V/m; Power Drift = 0.077 dB

Peak SAR (extrapolated) = 1.25 W/kg

SAR(1 g) = 0.342 mW/g; SAR(10 g) = 0.120 mW/g

Maximum value of SAR (measured) = 0.588 mW/g

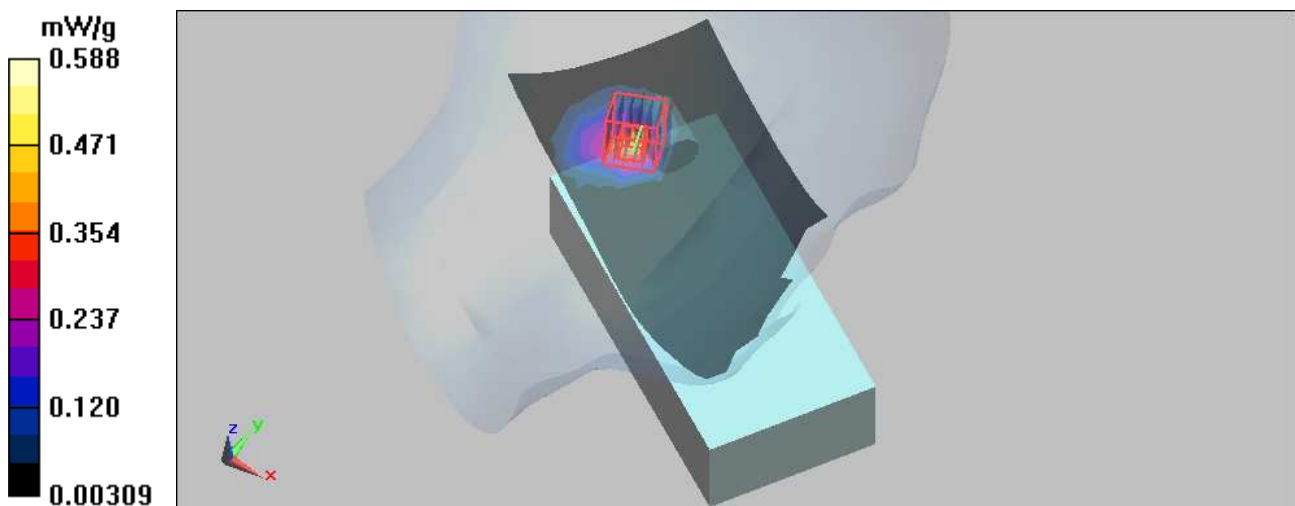

Test Laboratory: Bureau Veritas ADT

M25- A6_2D-Left Head-Cheek-11a-Ch124 / 1.5x Batt

DUT: EDA ; Type: MC 75A6

Communication System: 802.11a ; Frequency: 5620 MHz ; Duty Cycle: 1:1

Medium: HSL5800 Medium parameters used: $f = 5620 \text{ MHz}$; $\sigma = 5.11 \text{ mho/m}$; $\epsilon_r = 35.9$; $\rho = 1000 \text{ kg/m}^3$

Phantom section: Left Section ; DUT test position : Cheek ; Modulation type: BPSK

DASY5 Configuration:

- Probe: EX3DV3 - SN3504; ConvF(4.25, 4.25, 4.25); Calibrated: 2010/1/26
- Sensor-Surface: 2.5mm (Mechanical Surface Detection)
- Electronics: DAE3 Sn510; Calibrated: 2009/12/16
- Phantom: SAM with CRP; Type: SAM; Serial: TP-1485
- Measurement SW: DASY5, V5.2 Build 157; SEMCAD X Version 14.0 Build 57

Touch Position Ch124/Area Scan (10x20x1): Measurement grid: $dx=10\text{mm}$, $dy=10\text{mm}$
 Maximum value of SAR (measured) = 0.491 mW/g

Touch Position Ch124/Zoom Scan (7x7x9)/Cube 0: Measurement grid: $dx=4\text{mm}$, $dy=4\text{mm}$,
 $dz=2.5\text{mm}$

Reference Value = 7.85 V/m; Power Drift = 0.165 dB

Peak SAR (extrapolated) = 1.31 W/kg

SAR(1 g) = 0.338 mW/g; SAR(10 g) = 0.117 mW/g

Maximum value of SAR (measured) = 0.564 mW/g

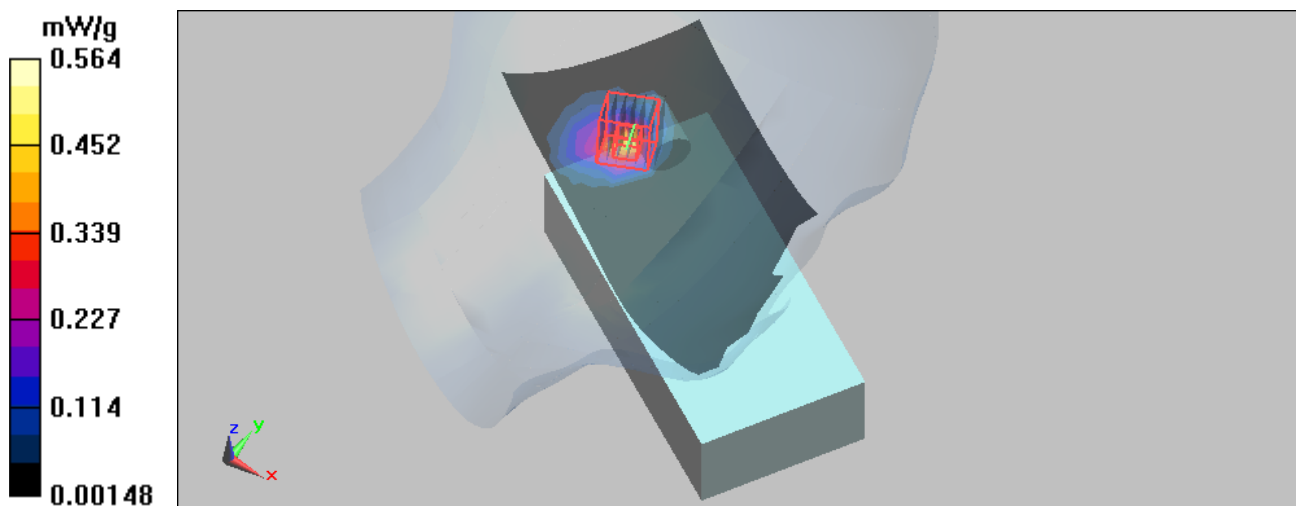

Test Laboratory: Bureau Veritas ADT

M26-A6_2D-Left Head-Cheek-11a-Ch136 / 1.5x Batt

DUT: EDA ; Type: MC75A6

Communication System: WiFi ; Frequency: 5680 MHz ; Duty Cycle: 1:1

Medium: HSL5800 Medium parameters used: $f = 5680$ MHz; $\sigma = 5.24$ mho/m; $\epsilon_r = 36.1$; $\rho = 1000$ kg/m³

Phantom section: Left Section ; DUT test position : Cheek ; Modulation type: BPSK

DASY5 Configuration:

- Probe: EX3DV3 - SN3504; ConvF(4.25, 4.25, 4.25); Calibrated: 2010/1/26
- Sensor-Surface: 2.5mm (Mechanical Surface Detection)
- Electronics: DAE3 Sn510; Calibrated: 2009/12/16
- Phantom: SAM with CRP; Type: SAM; Serial: TP-1485
- Measurement SW: DASY5, V5.2 Build 157; SEMCAD X Version 14.0 Build 57

Touch Position - Ch136/Area Scan (10x20x1): Measurement grid: dx=10mm, dy=10mm
Maximum value of SAR (measured) = 0.703 mW/g

Touch Position - Ch136/Zoom Scan (7x7x9)/Cube 0: Measurement grid: dx=4mm, dy=4mm, dz=2.5mm

Reference Value = 11.6 V/m; Power Drift = -0.087 dB

Peak SAR (extrapolated) = 1.42 W/kg

SAR(1 g) = **0.392** mW/g; SAR(10 g) = 0.135 mW/g

Maximum value of SAR (measured) = 0.708 mW/g

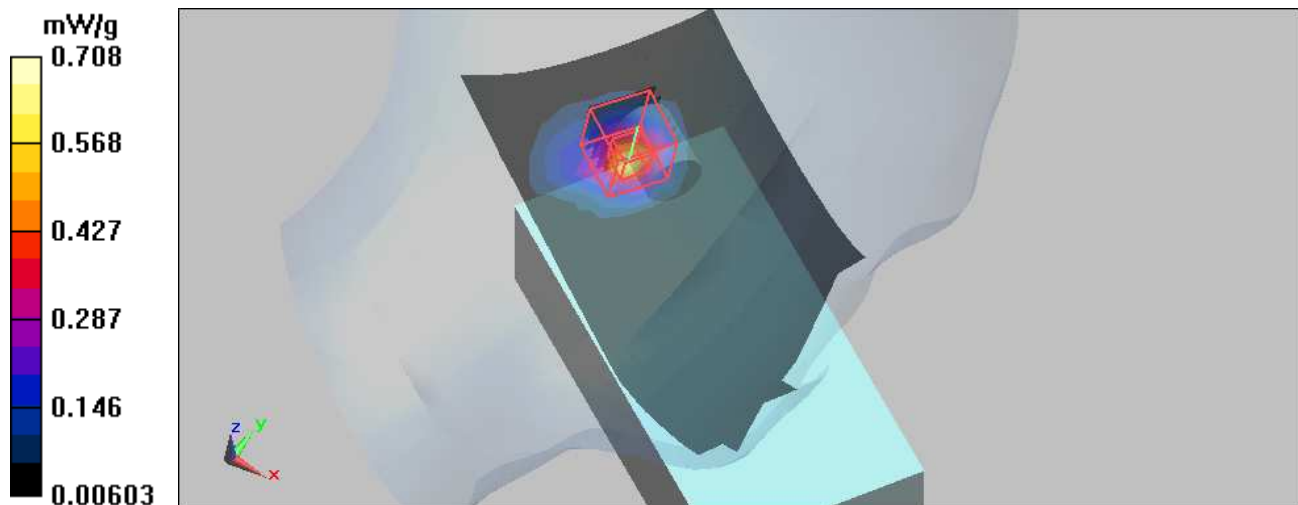

Test Laboratory: Bureau Veritas ADT

M27- A6_2D-Left Head-Cheek-11a-Ch140 / 1.5x Batt

DUT: EDA ; Type: MC 75A6

Communication System: 802.11a ; Frequency: 5700 MHz ; Duty Cycle: 1:1

Medium: HSL5800 Medium parameters used: $f = 5700$ MHz; $\sigma = 5.2$ mho/m; $\epsilon_r = 35.7$; $\rho = 1000$ kg/m³

Phantom section: Left Section ; DUT test position : Cheek ; Modulation type: BPSK

DASY5 Configuration:

- Probe: EX3DV3 - SN3504; ConvF(4.25, 4.25, 4.25); Calibrated: 2010/1/26
- Sensor-Surface: 2.5mm (Mechanical Surface Detection)
- Electronics: DAE3 Sn510; Calibrated: 2009/12/16
- Phantom: SAM with CRP; Type: SAM; Serial: TP-1485
- Measurement SW: DASY5, V5.2 Build 157; SEMCAD X Version 14.0 Build 57

Tilt Position Ch140/Area Scan (10x20x1): Measurement grid: dx=10mm, dy=10mm
 Maximum value of SAR (measured) = 0.380 mW/g

Tilt Position Ch140/Zoom Scan (7x7x9)/Cube 0: Measurement grid: dx=4mm, dy=4mm, dz=2.5mm

Reference Value = 6.81 V/m; Power Drift = 0.143 dB

Peak SAR (extrapolated) = 0.974 W/kg

SAR(1 g) = 0.256 mW/g; SAR(10 g) = 0.089 mW/g

Maximum value of SAR (measured) = 0.437 mW/g

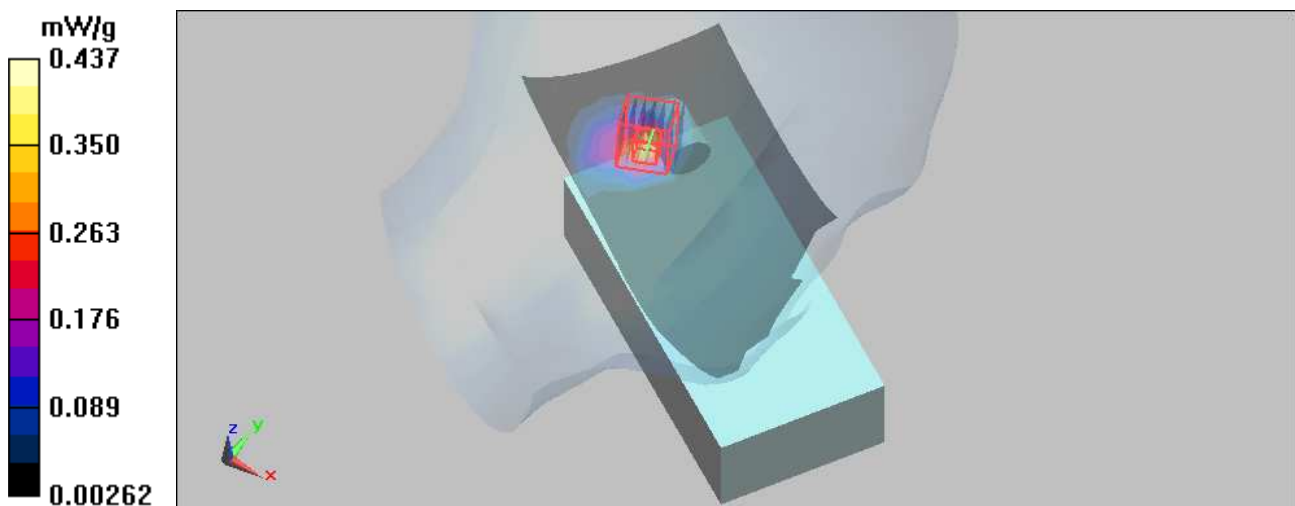

Test Laboratory: Bureau Veritas ADT

M28-A6_2D-Left Head-Tilt-11a-Ch40 / 1.5x Batt

DUT: EDA ; Type: MC75A6

Communication System: WiFi ; Frequency: 5200 MHz ; Duty Cycle: 1:1

Medium: HSL5800 Medium parameters used: $f = 5200 \text{ MHz}$; $\sigma = 4.66 \text{ mho/m}$; $\epsilon_r = 36.9$; $\rho = 1000 \text{ kg/m}^3$

Phantom section: Left Section ; DUT test position : Tilt ; Modulation type: BPSK

DASY5 Configuration:

- Probe: EX3DV3 - SN3504; ConvF(4.87, 4.87, 4.87); Calibrated: 2010/1/26
- Sensor-Surface: 2.5mm (Mechanical Surface Detection)
- Electronics: DAE3 Sn510; Calibrated: 2009/12/16
- Phantom: SAM with CRP; Type: SAM; Serial: TP-1485
- Measurement SW: DASY5, V5.2 Build 157; SEMCAD X Version 14.0 Build 57

Tilt Position - Ch40/Area Scan (10x20x1): Measurement grid: $dx=10\text{mm}$, $dy=10\text{mm}$

Maximum value of SAR (measured) = 0.475 mW/g

Tilt Position - Ch40/Zoom Scan (7x7x9)/Cube 0: Measurement grid: $dx=4\text{mm}$, $dy=4\text{mm}$, $dz=2.5\text{mm}$

Reference Value = 9.6 V/m; Power Drift = 0.144 dB

Peak SAR (extrapolated) = 0.984 W/kg

SAR(1 g) = **0.284 mW/g**; SAR(10 g) = 0.089 mW/g

Maximum value of SAR (measured) = 0.492 mW/g

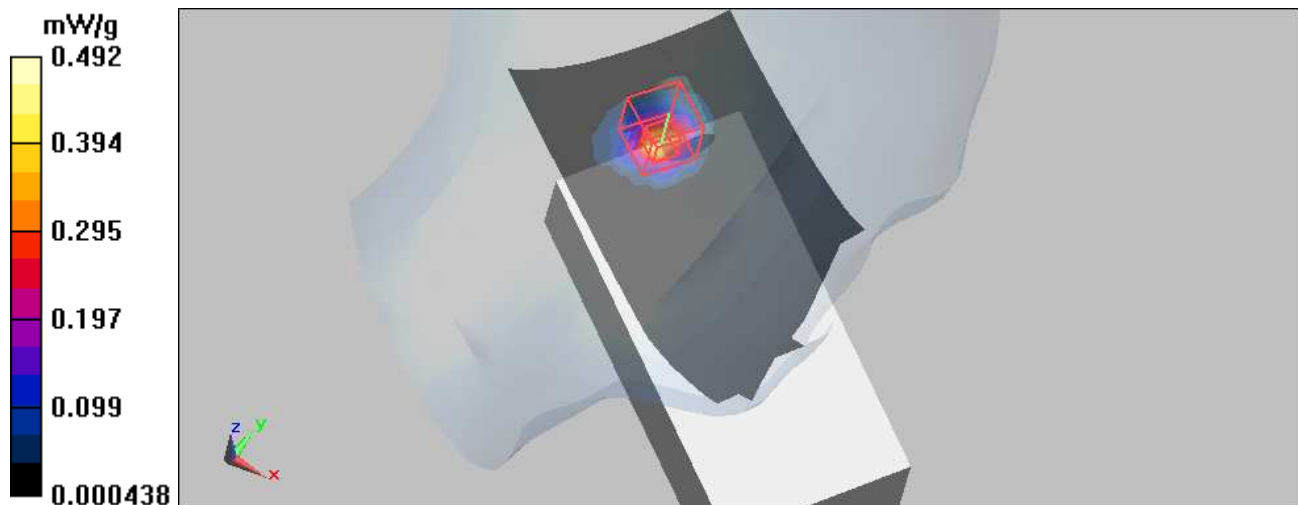

Test Laboratory: Bureau Veritas ADT

M29-A6_2D-Left Head-Tilt-11a-Ch64 / 1.5x Batt

DUT: EDA ; Type: MC75A6

Communication System: WiFi ; Frequency: 5320 MHz ; Duty Cycle: 1:1

Medium: HSL5800 Medium parameters used: $f = 5320 \text{ MHz}$; $\sigma = 4.8 \text{ mho/m}$; $\epsilon_r = 36.7$; $\rho = 1000 \text{ kg/m}^3$

Phantom section: Left Section ; DUT test position : Tilt ; Modulation type: BPSK

DASY5 Configuration:

- Probe: EX3DV3 - SN3504; ConvF(4.62, 4.62, 4.62); Calibrated: 2010/1/26
- Sensor-Surface: 2.5mm (Mechanical Surface Detection)
- Electronics: DAE3 Sn510; Calibrated: 2009/12/16
- Phantom: SAM with CRP; Type: SAM; Serial: TP-1485
- Measurement SW: DASY5, V5.2 Build 157; SEMCAD X Version 14.0 Build 57

Tilt Position - Ch64/Area Scan (10x20x1): Measurement grid: $dx=10\text{mm}$, $dy=10\text{mm}$

Maximum value of SAR (measured) = 0.981 mW/g

Tilt Position - Ch64/Zoom Scan (7x7x9)/Cube 0: Measurement grid: $dx=4\text{mm}$, $dy=4\text{mm}$, $dz=2.5\text{mm}$

Reference Value = 14.1 V/m; Power Drift = 0.024 dB

Peak SAR (extrapolated) = 2.12 W/kg

SAR(1 g) = 0.596 mW/g; SAR(10 g) = 0.189 mW/g

Maximum value of SAR (measured) = 1.05 mW/g

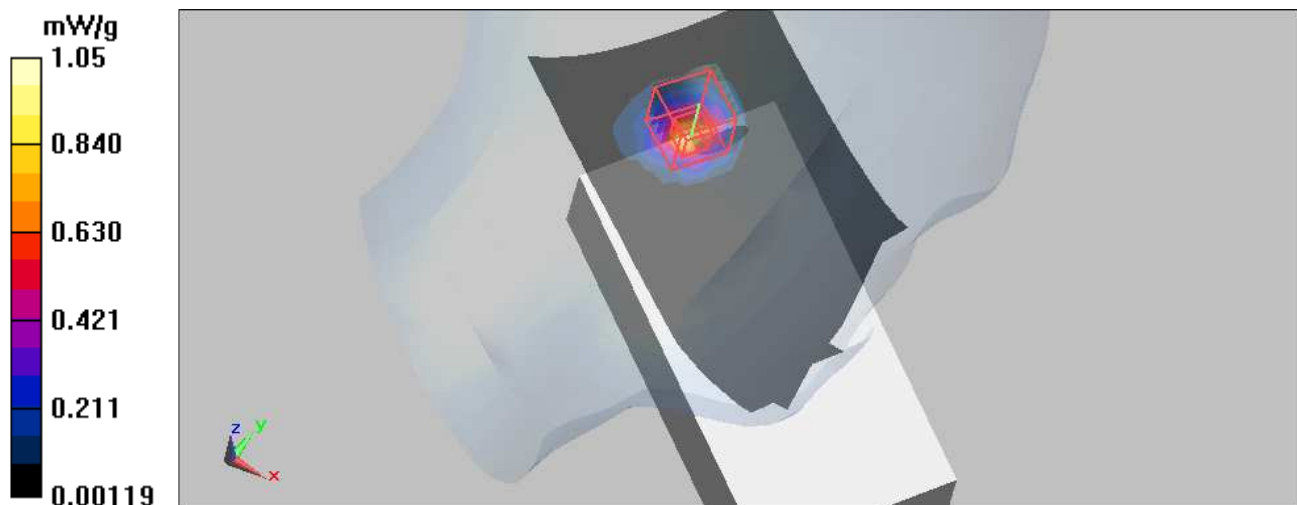

Test Laboratory: Bureau Veritas ADT

M30- A6_2D-Left Head-Tilt-11a-Ch100 / 1.5x Batt

DUT: EDA ; Type: MC75A6

Communication System: WiFi ; Frequency: 5500 MHz ; Duty Cycle: 1:1

Medium: HSL5800 Medium parameters used: $f = 5500 \text{ MHz}$; $\sigma = 4.96 \text{ mho/m}$; $\epsilon_r = 36.1$; $\rho = 1000 \text{ kg/m}^3$

Phantom section: Left Section ; DUT test position : Tilt ; Modulation type: BPSK

DASY5 Configuration:

- Probe: EX3DV3 - SN3504; ConvF(4.51, 4.51, 4.51); Calibrated: 2010/1/26
- Sensor-Surface: 2.5mm (Mechanical Surface Detection)
- Electronics: DAE3 Sn510; Calibrated: 2009/12/16
- Phantom: SAM with CRP; Type: SAM; Serial: TP-1485
- Measurement SW: DASY5, V5.2 Build 157; SEMCAD X Version 14.0 Build 57

Tilt Position - Ch100/Area Scan (10x20x1): Measurement grid: $dx=10\text{mm}$, $dy=10\text{mm}$
 Maximum value of SAR (measured) = 0.653 mW/g

Tilt Position - Ch100/Zoom Scan (7x7x9)/Cube 0: Measurement grid: $dx=4\text{mm}$, $dy=4\text{mm}$,
 $dz=2.5\text{mm}$

Reference Value = 12.2 V/m; Power Drift = 0.042 dB

Peak SAR (extrapolated) = 1.38 W/kg

SAR(1 g) = 0.399 mW/g; SAR(10 g) = 0.133 mW/g

Maximum value of SAR (measured) = 0.678 mW/g

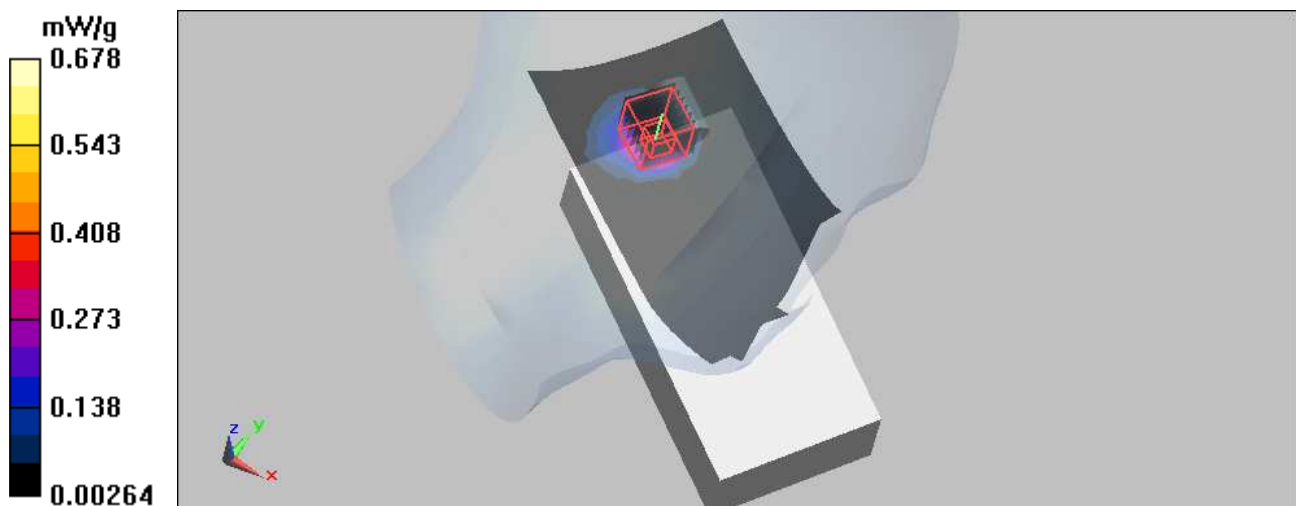

Test Laboratory: Bureau Veritas ADT

M31- A6_2D-Left Head-Tilt-11a-Ch104 / 1.5x Batt

DUT: EDA ; Type: MC75A6

Communication System: WiFi ; Frequency: 5520 MHz ; Duty Cycle: 1:1

Medium: HSL5800 Medium parameters used: $f = 5520 \text{ MHz}$; $\sigma = 4.98 \text{ mho/m}$; $\epsilon_r = 36$; $\rho = 1000 \text{ kg/m}^3$

Phantom section: Left Section ; DUT test position : Tilt; Modulation type: BPSK

DASY5 Configuration:

- Probe: EX3DV3 - SN3504; ConvF(4.51, 4.51, 4.51); Calibrated: 2010/1/26
- Sensor-Surface: 2.5mm (Mechanical Surface Detection)
- Electronics: DAE3 Sn510; Calibrated: 2009/12/16
- Phantom: SAM with CRP; Type: SAM; Serial: TP-1485
- Measurement SW: DASY5, V5.2 Build 157; SEMCAD X Version 14.0 Build 57

Tilt Position - Ch104/Area Scan (10x20x1): Measurement grid: $dx=10\text{mm}$, $dy=10\text{mm}$
 Maximum value of SAR (measured) = 0.609 mW/g

Tilt Position - Ch104/Zoom Scan (7x7x9)/Cube 0: Measurement grid: $dx=4\text{mm}$, $dy=4\text{mm}$,
 $dz=2.5\text{mm}$

Reference Value = 11.7 V/m; Power Drift = 0.034 dB

Peak SAR (extrapolated) = 1.36 W/kg

SAR(1 g) = 0.374 mW/g; SAR(10 g) = 0.125 mW/g

Maximum value of SAR (measured) = 0.638 mW/g

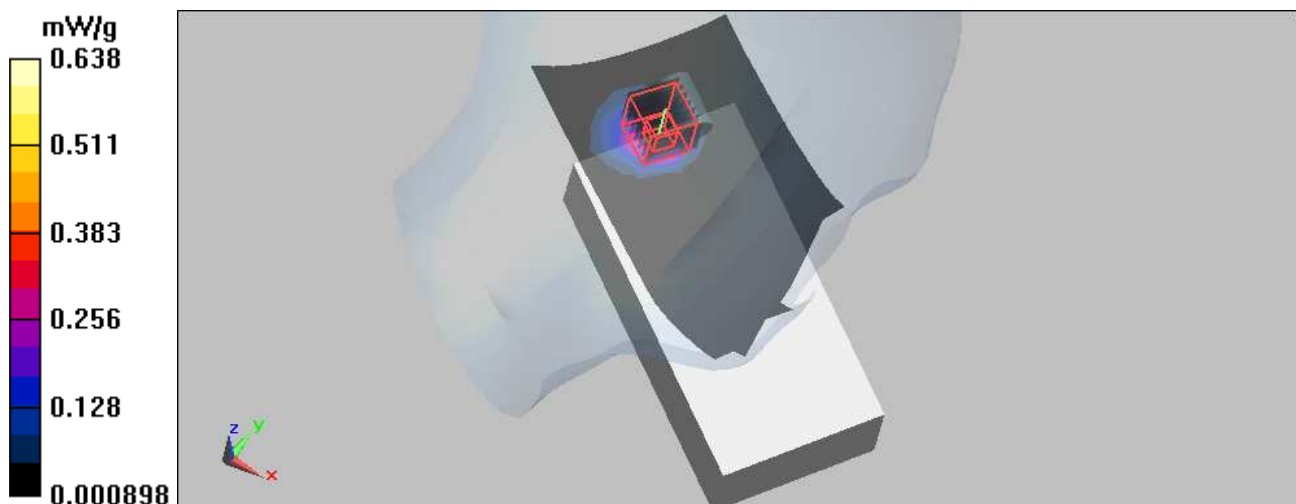

Test Laboratory: Bureau Veritas ADT

M32- A6_2D-Left Head-Tilt-11a-Ch116 / 1.5x Batt

DUT: EDA ; Type: MC75A6

Communication System: WiFi ; Frequency: 5580 MHz ; Duty Cycle: 1:1

Medium: HSL5800 Medium parameters used: $f = 5580 \text{ MHz}$; $\sigma = 5.06 \text{ mho/m}$; $\epsilon_r = 35.9$; $\rho = 1000 \text{ kg/m}^3$

Phantom section: Left Section ; DUT test position : Tilt; Modulation type: BPSK

DASY5 Configuration:

- Probe: EX3DV3 - SN3504; ConvF(4.25, 4.25, 4.25); Calibrated: 2010/1/26
- Sensor-Surface: 2.5mm (Mechanical Surface Detection)
- Electronics: DAE3 Sn510; Calibrated: 2009/12/16
- Phantom: SAM with CRP; Type: SAM; Serial: TP-1485
- Measurement SW: DASY5, V5.2 Build 157; SEMCAD X Version 14.0 Build 57

Tilt Position - Ch116/Area Scan (10x20x1): Measurement grid: $dx=10\text{mm}$, $dy=10\text{mm}$
 Maximum value of SAR (measured) = 0.531 mW/g

Tilt Position - Ch116/Zoom Scan (7x7x9)/Cube 0: Measurement grid: $dx=4\text{mm}$, $dy=4\text{mm}$,
 $dz=2.5\text{mm}$

Reference Value = 11 V/m; Power Drift = -0.026 dB

Peak SAR (extrapolated) = 1.18 W/kg

SAR(1 g) = 0.329 mW/g; SAR(10 g) = 0.109 mW/g

Maximum value of SAR (measured) = 0.561 mW/g

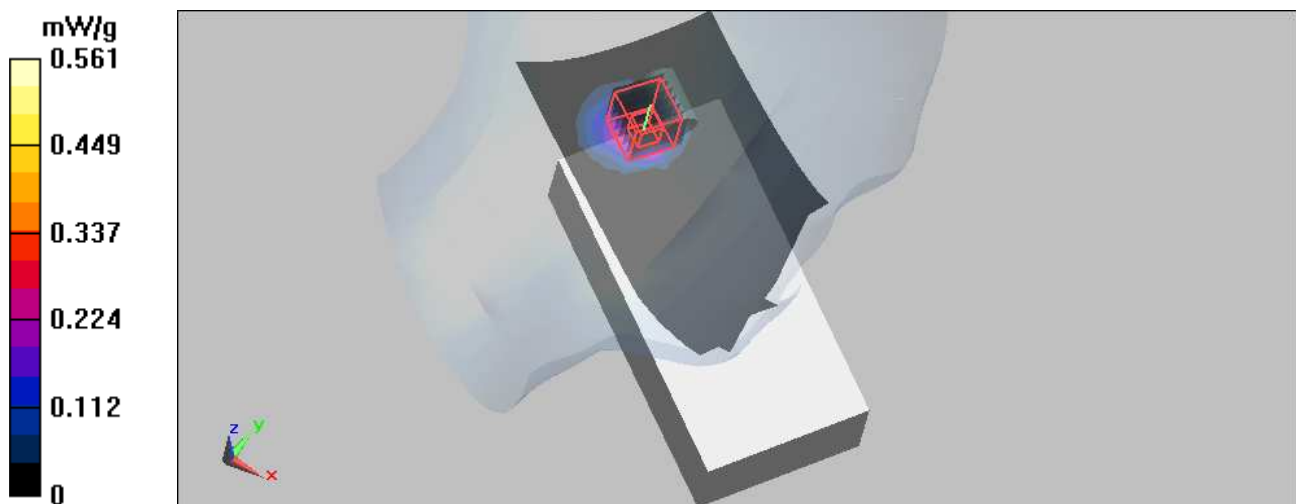

Test Laboratory: Bureau Veritas ADT

M33- A6_2D-Left Head-Tilt-11a-Ch120 / 1.5x Batt

DUT: EDA ; Type: MC75A6

Communication System: WiFi ; Frequency: 5600 MHz ; Duty Cycle: 1:1

Medium: HSL5800 Medium parameters used: $f = 5600$ MHz; $\sigma = 5.09$ mho/m; $\epsilon_r = 35.9$; $\rho = 1000$ kg/m³

Phantom section: Left Section ; DUT test position : Tilt; Modulation type: BPSK

DASY5 Configuration:

- Probe: EX3DV3 - SN3504; ConvF(4.25, 4.25, 4.25); Calibrated: 2010/1/26
- Sensor-Surface: 2.5mm (Mechanical Surface Detection)
- Electronics: DAE3 Sn510; Calibrated: 2009/12/16
- Phantom: SAM with CRP; Type: SAM; Serial: TP-1485
- Measurement SW: DASY5, V5.2 Build 157; SEMCAD X Version 14.0 Build 57

Tilt Position - Ch120/Area Scan (10x20x1): Measurement grid: dx=10mm, dy=10mm
 Maximum value of SAR (measured) = 0.556 mW/g

Tilt Position - Ch120/Zoom Scan (7x7x9)/Cube 0: Measurement grid: dx=4mm, dy=4mm, dz=2.5mm

Reference Value = 11.2 V/m; Power Drift = 0.067 dB

Peak SAR (extrapolated) = 1.24 W/kg

SAR(1 g) = 0.343 mW/g; SAR(10 g) = 0.114 mW/g

Maximum value of SAR (measured) = 0.581 mW/g

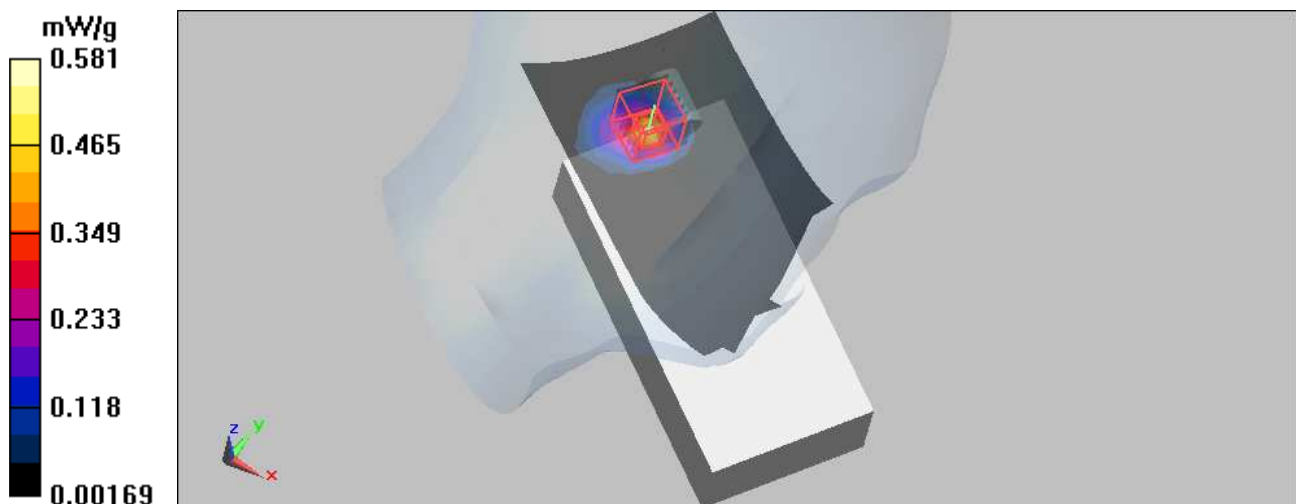

Test Laboratory: Bureau Veritas ADT

M34- A6_2D-Left Head-Tilt-11a-Ch124 / 1.5x Batt

DUT: EDA ; Type: MC75A6

Communication System: WiFi ; Frequency: 5620 MHz ; Duty Cycle: 1:1

Medium: HSL5800 Medium parameters used: $f = 5620 \text{ MHz}$; $\sigma = 5.11 \text{ mho/m}$; $\epsilon_r = 35.9$; $\rho = 1000 \text{ kg/m}^3$

Phantom section: Left Section ; DUT test position : Tilt; Modulation type: BPSK

DASY5 Configuration:

- Probe: EX3DV3 - SN3504; ConvF(4.25, 4.25, 4.25); Calibrated: 2010/1/26
- Sensor-Surface: 2.5mm (Mechanical Surface Detection)
- Electronics: DAE3 Sn510; Calibrated: 2009/12/16
- Phantom: SAM with CRP; Type: SAM; Serial: TP-1485
- Measurement SW: DASY5, V5.2 Build 157; SEMCAD X Version 14.0 Build 57

Tilt Position - Ch124/Area Scan (10x20x1): Measurement grid: $dx=10\text{mm}$, $dy=10\text{mm}$
 Maximum value of SAR (measured) = 0.588 mW/g

Tilt Position - Ch124/Zoom Scan (7x7x9)/Cube 0: Measurement grid: $dx=4\text{mm}$, $dy=4\text{mm}$,
 $dz=2.5\text{mm}$

Reference Value = 11.5 V/m; Power Drift = 0.047 dB

Peak SAR (extrapolated) = 1.35 W/kg

SAR(1 g) = 0.366 mW/g; SAR(10 g) = 0.120 mW/g

Maximum value of SAR (measured) = 0.619 mW/g

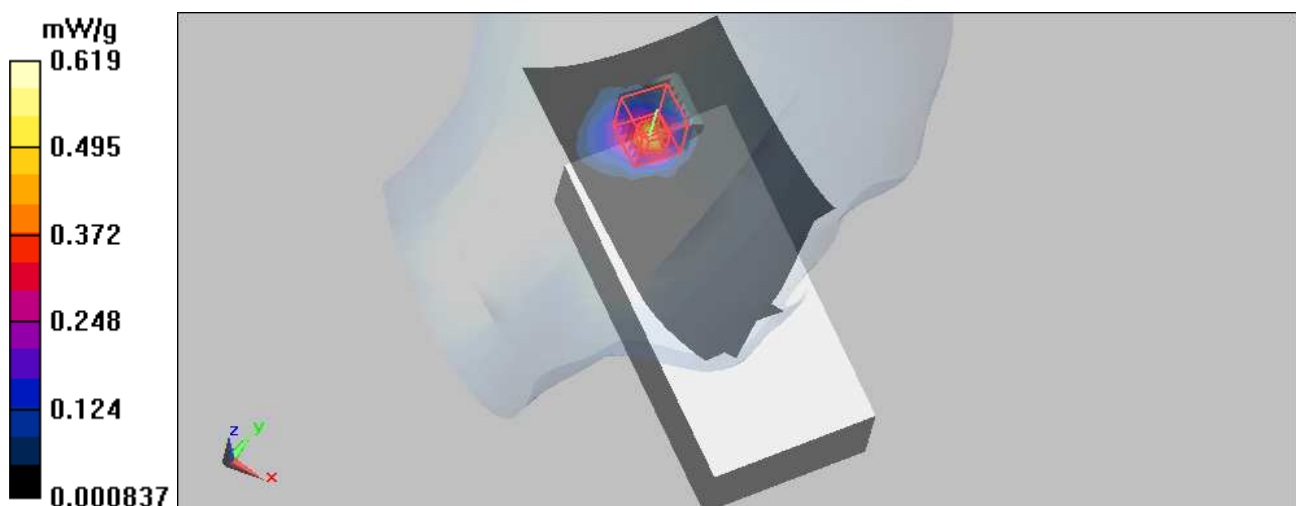

Test Laboratory: Bureau Veritas ADT

M35-A6_2D-Left Head-Tilt-11a-Ch136 / 1.5x Batt

DUT: EDA ; Type: MC75A6

Communication System: WiFi ; Frequency: 5680 MHz ; Duty Cycle: 1:1

Medium: HSL5800 Medium parameters used: $f = 5680$ MHz; $\sigma = 5.24$ mho/m; $\epsilon_r = 36.1$; $\rho = 1000$ kg/m³

Phantom section: Left Section ; DUT test position : Tilt ; Modulation type: BPSK

DASY5 Configuration:

- Probe: EX3DV3 - SN3504; ConvF(4.25, 4.25, 4.25); Calibrated: 2010/1/26
- Sensor-Surface: 2.5mm (Mechanical Surface Detection)
- Electronics: DAE3 Sn510; Calibrated: 2009/12/16
- Phantom: SAM with CRP; Type: SAM; Serial: TP-1485
- Measurement SW: DASY5, V5.2 Build 157; SEMCAD X Version 14.0 Build 57

Tilt Position - Ch136/Area Scan (10x20x1): Measurement grid: dx=10mm, dy=10mm

Maximum value of SAR (measured) = 0.678 mW/g

Tilt Position - Ch136/Zoom Scan (7x7x9)/Cube 0: Measurement grid: dx=4mm, dy=4mm, dz=2.5mm

Reference Value = 11.2 V/m; Power Drift = 0.048 dB

Peak SAR (extrapolated) = 1.48 W/kg

SAR(1 g) = **0.384** mW/g; SAR(10 g) = 0.122 mW/g

Maximum value of SAR (measured) = 0.704 mW/g

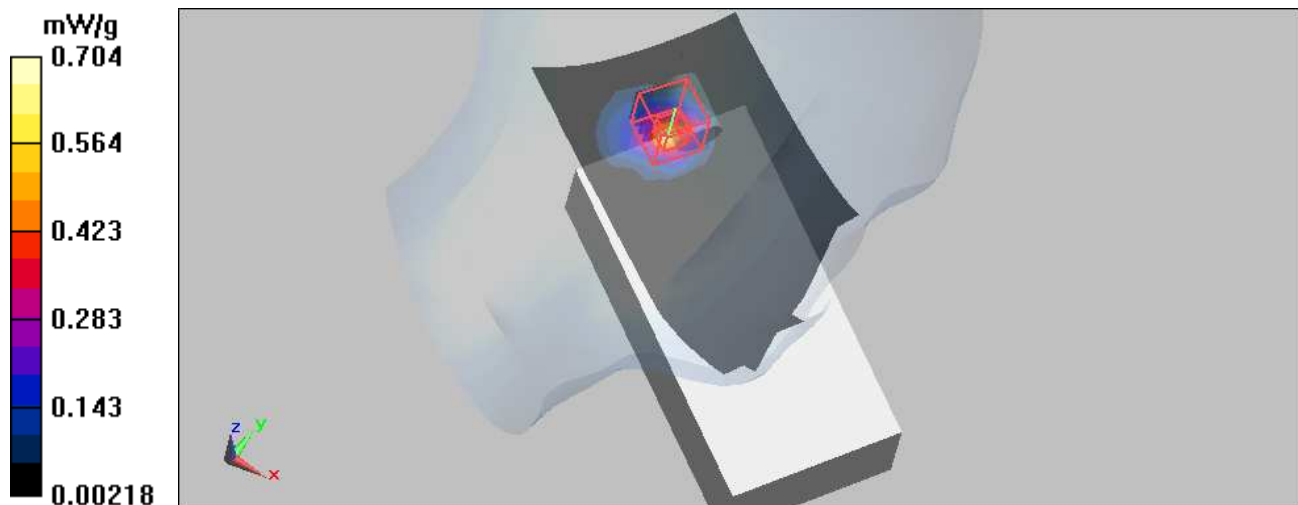

Test Laboratory: Bureau Veritas ADT

M36- A6_2D-Left Head-Tilt-11a-Ch140 / 1.5x Batt

DUT: EDA ; Type: MC75A6

Communication System: WiFi ; Frequency: 5700 MHz ; Duty Cycle: 1:1

Medium: HSL5800 Medium parameters used: $f = 5700 \text{ MHz}$; $\sigma = 5.2 \text{ mho/m}$; $\epsilon_r = 35.7$; $\rho = 1000 \text{ kg/m}^3$

Phantom section: Left Section ; DUT test position : Tilt; Modulation type: BPSK

DASY5 Configuration:

- Probe: EX3DV3 - SN3504; ConvF(4.25, 4.25, 4.25); Calibrated: 2010/1/26
- Sensor-Surface: 2.5mm (Mechanical Surface Detection)
- Electronics: DAE3 Sn510; Calibrated: 2009/12/16
- Phantom: SAM with CRP; Type: SAM; Serial: TP-1485
- Measurement SW: DASY5, V5.2 Build 157; SEMCAD X Version 14.0 Build 57

Tilt Position - Ch140/Area Scan (10x20x1): Measurement grid: $dx=10\text{mm}$, $dy=10\text{mm}$
 Maximum value of SAR (measured) = 0.442 mW/g

Tilt Position - Ch140/Zoom Scan (7x7x9)/Cube 0: Measurement grid: $dx=4\text{mm}$, $dy=4\text{mm}$,
 $dz=2.5\text{mm}$

Reference Value = 9.86 V/m; Power Drift = -0.033 dB

Peak SAR (extrapolated) = 0.995 W/kg

SAR(1 g) = 0.268 mW/g; SAR(10 g) = 0.088 mW/g

Maximum value of SAR (measured) = 0.451 mW/g

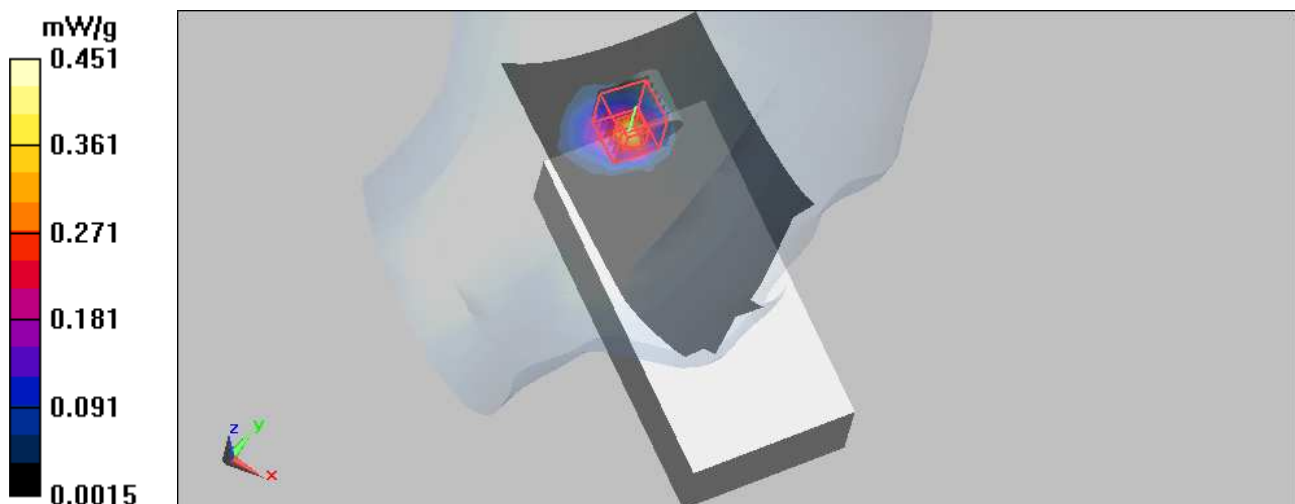

Test Laboratory: Bureau Veritas ADT

M37-A6_2D-Body-11A-Ch40 / LCD Up / 1.5x Batt

DUT: EDA ; Type: MC 75A6

Communication System: 802.11a ; Frequency: 5200 MHz ; Duty Cycle: 1:1 ; Modulation type: BPSK
 Medium: MSL5800 Medium parameters used: $f = 5200 \text{ MHz}$; $\sigma = 5.37 \text{ mho/m}$; $\epsilon_r = 51.4$; $\rho = 1000 \text{ kg/m}^3$
 Phantom section: Flat Section ; Separation distance : 0 mm (The front side of the EUT to the Phantom)

DASY5 Configuration:

- Probe: EX3DV3 - SN3504; ConvF(4.45, 4.45, 4.45); Calibrated: 2010/1/26
- Sensor-Surface: 2.5mm (Mechanical Surface Detection)
- Electronics: DAE3 Sn510; Calibrated: 2009/12/16
- Phantom: SAM with CRP; Type: SAM ; Serial: TP-1485
- Measurement SW: DASY5, V5.2 Build 157; SEMCAD X Version 14.0 Build 57

Flat Section Mid ch 40/Area Scan (12x20x1): Measurement grid: dx=10mm, dy=10mm
 Maximum value of SAR (measured) = 0.049 mW/g

Flat Section Mid ch 40/Zoom Scan (7x7x9)/Cube 0: Measurement grid: dx=4mm, dy=4mm, dz=2.5mm

Reference Value = 1.01 V/m; Power Drift = -0.072 dB

Peak SAR (extrapolated) = 0.097 W/kg

SAR(1 g) = 0.033 mW/g; SAR(10 g) = 0.014 mW/g

Maximum value of SAR (measured) = 0.052 mW/g

Flat Section Mid ch 40/Zoom Scan (7x7x9)/Cube 1: Measurement grid: dx=4mm, dy=4mm, dz=2.5mm

Reference Value = 1.01 V/m; Power Drift = -0.072 dB

Peak SAR (extrapolated) = 0.201 W/kg

SAR(1 g) = 0.035 mW/g; SAR(10 g) = 0.017 mW/g

Maximum value of SAR (measured) = 0.056 mW/g

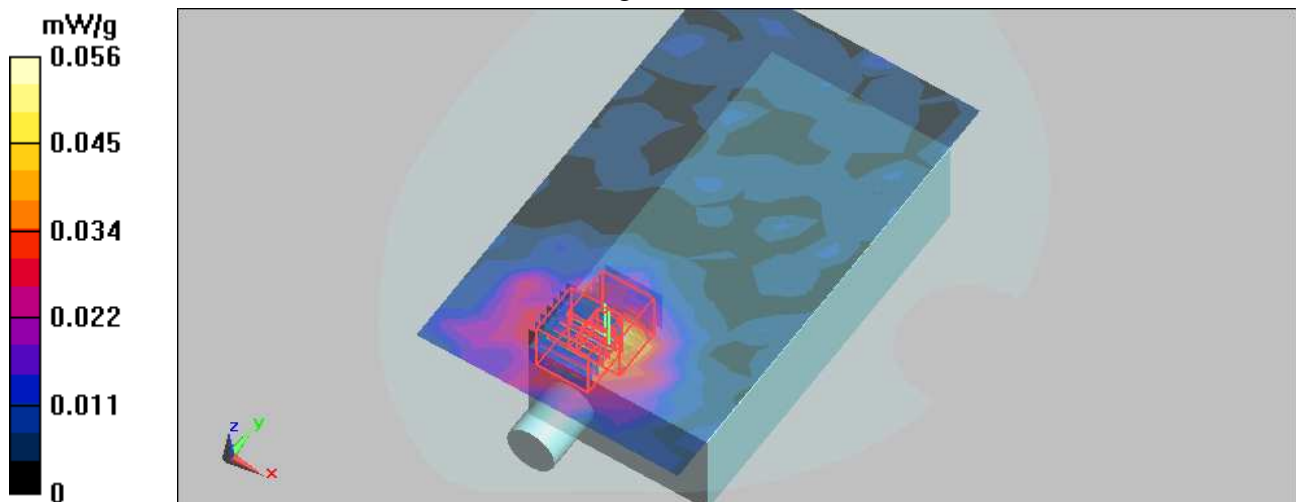

Test Laboratory: Bureau Veritas ADT

M38-A6_2D-Body-11A-Ch64 / LCD Up / 1.5x Batt

DUT: EDA ; Type: MC 75A6

Communication System: 802.11a ; Frequency: 5320 MHz ; Duty Cycle: 1:1 ; Modulation type: BPSK
 Medium: MSL5800 Medium parameters used: $f = 5320 \text{ MHz}$; $\sigma = 5.52 \text{ mho/m}$; $\epsilon_r = 51.2$; $\rho = 1000 \text{ kg/m}^3$
 Phantom section: Flat Section ; Separation distance : 0 mm (The front side of the EUT to the Phantom)

DASY5 Configuration:

- Probe: EX3DV3 - SN3504; ConvF(4.18, 4.18, 4.18); Calibrated: 2010/1/26
- Sensor-Surface: 2.5mm (Mechanical Surface Detection)
- Electronics: DAE3 Sn510; Calibrated: 2009/12/16
- Phantom: SAM with CRP; Type: SAM ; Serial: TP-1485
- Measurement SW: DASY5, V5.2 Build 157; SEMCAD X Version 14.0 Build 57

Flat Section Mid ch 64/Area Scan (12x20x1): Measurement grid: dx=10mm, dy=10mm

Maximum value of SAR (measured) = 0.071 mW/g

Flat Section Mid ch 64/Zoom Scan (7x7x9)/Cube 0: Measurement grid: dx=4mm, dy=4mm, dz=2.5mm

Reference Value = 1.53 V/m; Power Drift = 0.109 dB

Peak SAR (extrapolated) = 0.216 W/kg

SAR(1 g) = 0.051 mW/g; SAR(10 g) = 0.022 mW/g

Maximum value of SAR (measured) = 0.079 mW/g

Flat Section Mid ch 64/Zoom Scan (7x7x9)/Cube 1: Measurement grid: dx=4mm, dy=4mm, dz=2.5mm

Reference Value = 1.53 V/m; Power Drift = 0.109 dB

Peak SAR (extrapolated) = 0.146 W/kg

SAR(1 g) = 0.034 mW/g; SAR(10 g) = 0.016 mW/g

Maximum value of SAR (measured) = 0.066 mW/g

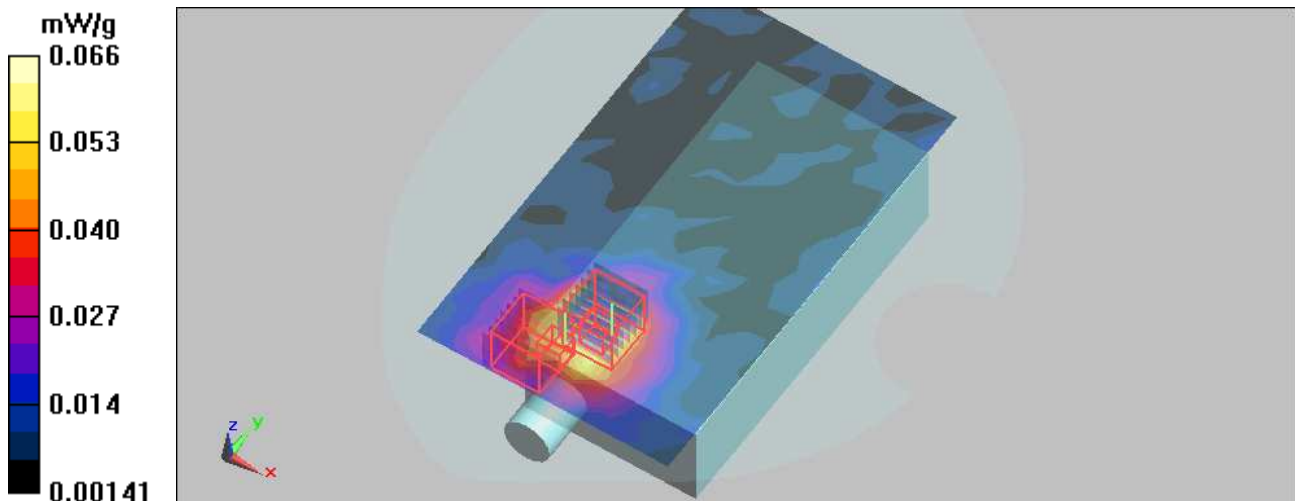

Test Laboratory: Bureau Veritas ADT

M39-A6_2D-Body-11A-Ch136 / LCD Up / 1.5x Batt

DUT: EDA ; Type: MC 75A6

Communication System: 802.11a ; Frequency: 5680 MHz ; Duty Cycle: 1:1 ; Modulation type: BPSK
 Medium: MSL5800 Medium parameters used: $f = 5680$ MHz; $\sigma = 6.06$ mho/m; $\epsilon_r = 50.5$; $\rho = 1000$ kg/m³
 Phantom section: Flat Section ; Separation distance : 0 mm (The front side of the EUT to the Phantom)

DASY5 Configuration:

- Probe: EX3DV3 - SN3504; ConvF(3.7, 3.7, 3.7); Calibrated: 2010/1/26
- Sensor-Surface: 2.5mm (Mechanical Surface Detection)
- Electronics: DAE3 Sn510; Calibrated: 2009/12/16
- Phantom: SAM with CRP; Type: SAM ; Serial: TP-1485
- Measurement SW: DASY5, V5.2 Build 157; SEMCAD X Version 14.0 Build 57

Flat Section Mid ch 136/Area Scan (12x20x1): Measurement grid: dx=10mm, dy=10mm

Maximum value of SAR (measured) = 0.080 mW/g

Flat Section Mid ch 136/Zoom Scan (7x7x9)/Cube 0: Measurement grid: dx=4mm, dy=4mm, dz=2.5mm

Reference Value = 0.975 V/m; Power Drift = 0.19 dB

Peak SAR (extrapolated) = 0.177 W/kg

SAR(1 g) = 0.052 mW/g; SAR(10 g) = 0.024 mW/g

Maximum value of SAR (measured) = 0.085 mW/g

Flat Section Mid ch 136/Zoom Scan (7x7x9)/Cube 1: Measurement grid: dx=4mm, dy=4mm, dz=2.5mm

Reference Value = 0.975 V/m; Power Drift = 0.19 dB

Peak SAR (extrapolated) = 0.164 W/kg

SAR(1 g) = 0.048 mW/g; SAR(10 g) = 0.021 mW/g

Maximum value of SAR (measured) = 0.082 mW/g

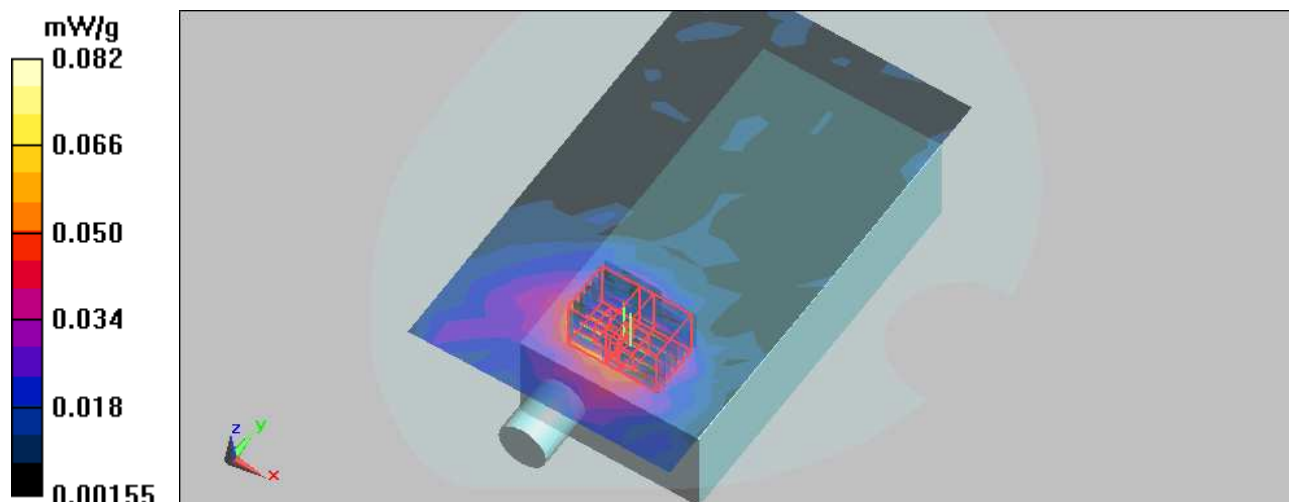

Test Laboratory: Bureau Veritas ADT

M40-A6_2D-Body-11A-Ch40 / LCD Down / 1.5x Batt

DUT: EDA ; Type: MC 75A6

Communication System: 802.11a ; Frequency: 5200 MHz ; Duty Cycle: 1:1 ; Modulation type: BPSK
 Medium: MSL5800 Medium parameters used: $f = 5200$ MHz; $\sigma = 5.37$ mho/m; $\epsilon_r = 51.4$; $\rho = 1000$ kg/m³
 Phantom section: Flat Section ; Separation distance : 0 mm (The back side of the EUT to the Phantom)

DASY5 Configuration:

- Probe: EX3DV3 - SN3504; ConvF(4.45, 4.45, 4.45); Calibrated: 2010/1/26
- Sensor-Surface: 2.5mm (Mechanical Surface Detection)
- Electronics: DAE3 Sn510; Calibrated: 2009/12/16
- Phantom: SAM with CRP; Type: SAM ; Serial: TP-1485
- Measurement SW: DASY5, V5.2 Build 157; SEMCAD X Version 14.0 Build 57

Flat Section Mid Ch40/Area Scan (12x20x1): Measurement grid: dx=10mm, dy=10mm
 Maximum value of SAR (measured) = 0.012 mW/g

Flat Section Mid Ch40/Zoom Scan (7x7x9)/Cube 0: Measurement grid: dx=4mm, dy=4mm, dz=2.5mm

Reference Value = 0.808 V/m; Power Drift = -0.071 dB

Peak SAR (extrapolated) = 0.064 W/kg

SAR(1 g) = 0.0033 mW/g; SAR(10 g) = 0.00123 mW/g

Maximum value of SAR (measured) = 0.014 mW/g

Flat Section Mid Ch40/Zoom Scan (7x7x9)/Cube 1: Measurement grid: dx=4mm, dy=4mm, dz=2.5mm

Reference Value = 0.808 V/m; Power Drift = -0.071 dB

Peak SAR (extrapolated) = 0.026 W/kg

SAR(1 g) = 0.00319 mW/g; SAR(10 g) = 0.00166 mW/g

Maximum value of SAR (measured) = 0.015 mW/g

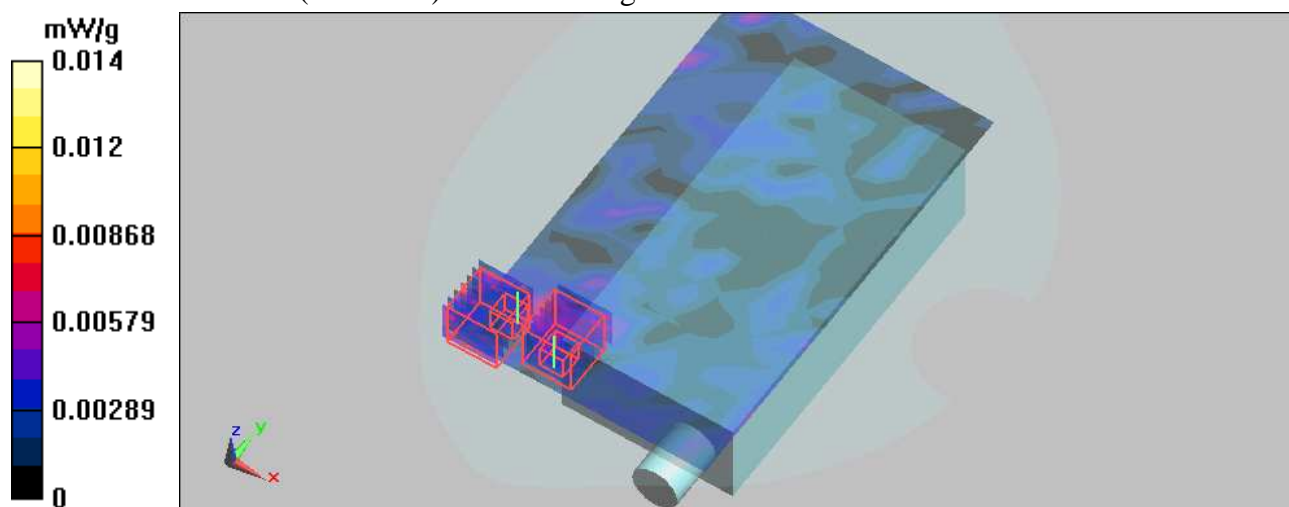

Test Laboratory: Bureau Veritas ADT

M41-A6_2D-Body-11A-Ch64 / LCD Down / 1.5x Batt

DUT: EDA ; Type: MC 75A6

Communication System: 802.11a ; Frequency: 5320 MHz ; Duty Cycle: 1:1 ; Modulation type: BPSK
 Medium: MSL5800 Medium parameters used: $f = 5320 \text{ MHz}$; $\sigma = 5.52 \text{ mho/m}$; $\epsilon_r = 51.2$; $\rho = 1000 \text{ kg/m}^3$
 Phantom section: Flat Section ; Separation distance : 0 mm (The back side of the EUT to the Phantom)

DASY5 Configuration:

- Probe: EX3DV3 - SN3504; ConvF(4.18, 4.18, 4.18); Calibrated: 2010/1/26
- Sensor-Surface: 2.5mm (Mechanical Surface Detection)
- Electronics: DAE3 Sn510; Calibrated: 2009/12/16
- Phantom: SAM with CRP; Type: SAM ; Serial: TP-1485
- Measurement SW: DASY5, V5.2 Build 157; SEMCAD X Version 14.0 Build 57

Flat Section Mid Ch64/Area Scan (12x20x1): Measurement grid: $dx=10\text{mm}$, $dy=10\text{mm}$
 Maximum value of SAR (measured) = 0.013 mW/g

Flat Section Mid Ch64/Zoom Scan (7x7x9)/Cube 0: Measurement grid: $dx=4\text{mm}$, $dy=4\text{mm}$,
 $dz=2.5\text{mm}$

Reference Value = 0.447 V/m; Power Drift = 0.126 dB

Peak SAR (extrapolated) = 0.098 W/kg

SAR(1 g) = 0.0081 mW/g; SAR(10 g) = 0.00307 mW/g

Maximum value of SAR (measured) = 0.020 mW/g

Flat Section Mid Ch64/Zoom Scan (7x7x9)/Cube 1: Measurement grid: $dx=4\text{mm}$, $dy=4\text{mm}$,
 $dz=2.5\text{mm}$

Reference Value = 0.447 V/m; Power Drift = 0.126 dB

Peak SAR (extrapolated) = 0.198 W/kg

SAR(1 g) = 0.00177 mW/g; SAR(10 g) = 0.000637 mW/g

Maximum value of SAR (measured) = 0.198 mW/g

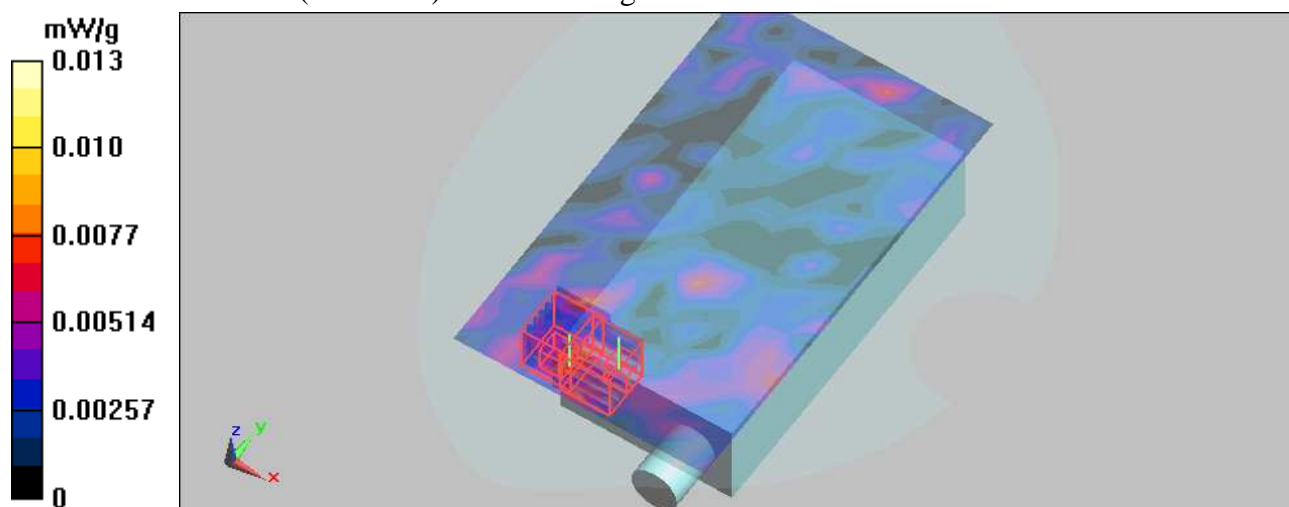

Test Laboratory: Bureau Veritas ADT

M42-A6_2D-Body-11A-Ch136 / LCD Down / 1.5x Batt

DUT: EDA ; Type: MC 75A6

Communication System: 802.11a ; Frequency: 5680 MHz ; Duty Cycle: 1:1 ; Modulation type: BPSK
 Medium: MSL5800 Medium parameters used: $f = 5680$ MHz; $\sigma = 6.06$ mho/m; $\epsilon_r = 50.5$; $\rho = 1000$ kg/m³
 Phantom section: Flat Section ; Separation distance : 0 mm (The back side of the EUT to the Phantom)

DASY5 Configuration:

- Probe: EX3DV3 - SN3504; ConvF(3.7, 3.7, 3.7); Calibrated: 2010/1/26
- Sensor-Surface: 2.5mm (Mechanical Surface Detection)
- Electronics: DAE3 Sn510; Calibrated: 2009/12/16
- Phantom: SAM with CRP; Type: SAM ; Serial: TP-1485
- Measurement SW: DASY5, V5.2 Build 157; SEMCAD X Version 14.0 Build 57

Flat Section Mid Ch136/Area Scan (12x20x1): Measurement grid: dx=10mm, dy=10mm

Maximum value of SAR (measured) = 0.014 mW/g

Flat Section Mid Ch136/Zoom Scan (7x7x9)/Cube 0: Measurement grid: dx=4mm, dy=4mm, dz=2.5mm

Reference Value = 1.35 V/m; Power Drift = -0.02 dB

Peak SAR (extrapolated) = 0.040 W/kg

SAR(1 g) = 0.00367 mW/g; SAR(10 g) = 0.00185 mW/g

Maximum value of SAR (measured) = 0.024 mW/g

Flat Section Mid Ch136/Zoom Scan (7x7x9)/Cube 1: Measurement grid: dx=4mm, dy=4mm, dz=2.5mm

Reference Value = 1.35 V/m; Power Drift = -0.02 dB

Peak SAR (extrapolated) = 0.076 W/kg

SAR(1 g) = 0.00798 mW/g; SAR(10 g) = 0.00456 mW/g

Maximum value of SAR (measured) = 0.025 mW/g

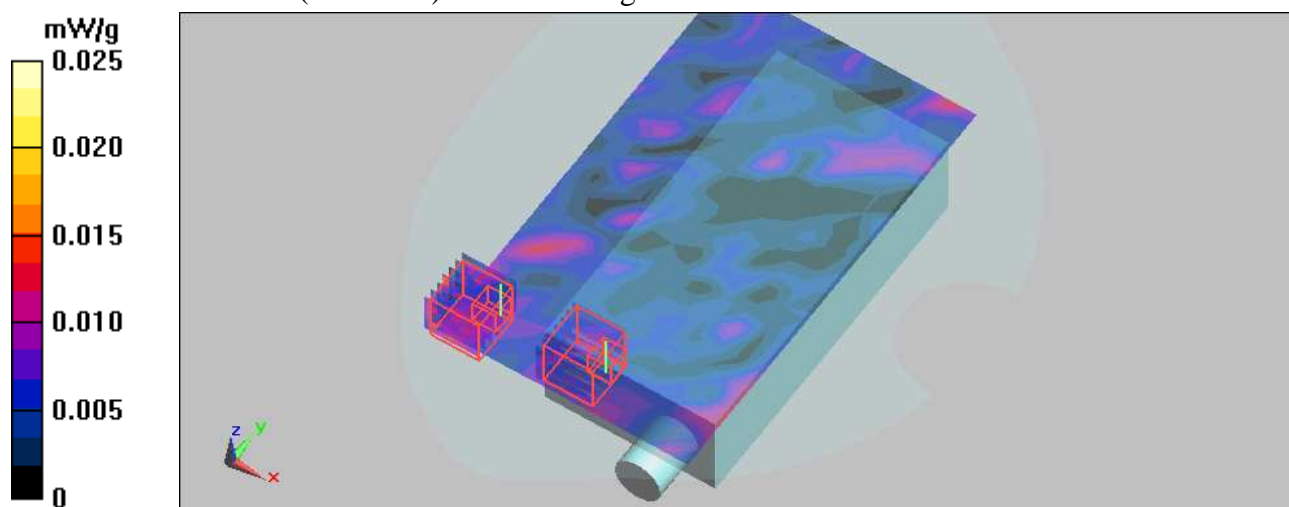

Test Laboratory: Bureau Veritas ADT

System Performance Check-HSL5200MHz 4-16

DUT: Dipole D5GHzV2 ; Type: D5GHzV2 ; Serial: 1018 ; Test Frequency: 5200 MHz

Communication System: CW-5GHz ; Frequency: 5200 MHz; Duty Cycle: 1:1; Modulation type: CW
 Medium: HSL5800; Medium parameters used: $f = 5200$ MHz; $\sigma = 4.66$ mho/m; $\epsilon_r = 36.9$; $\rho = 1000$ kg/m³ ;
 Liquid level : 153 mm

Phantom section: Flat Section ; Separation distance : 10 mm (The feetpoint of the dipole to the Phantom) Air temp. : 23.3 degrees ; Liquid temp. : 23.0 degrees

DASY5 Configuration:

- Probe: EX3DV3 - SN3504; ConvF(4.87, 4.87, 4.87); Calibrated: 2010/1/26
- Sensor-Surface: 2mm (Mechanical Surface Detection)
- Electronics: DAE3 Sn510; Calibrated: 2009/12/16
- Phantom: SAM with CRP; Type: SAM; Serial: TP-1485
- Measurement SW: DASY5, V5.2 Build 157; SEMCAD X Version 14.0 Build 57

System Performance Check with D5GHzV2 Dipole (uniform grid)/d=10mm, Pin=100mW, f=5200 MHz/Area Scan (10x10x1): Measurement grid: dx=10mm, dy=10mm
 Maximum value of SAR (measured) = 11.9 mW/g

System Performance Check with D5GHzV2 Dipole (uniform grid)/d=10mm, Pin=100mW, f=5200 MHz/Zoom Scan (4x4x2.5mm), dist=2mm (8x8x10)/Cube 0:
 Measurement grid: dx=4mm, dy=4mm, dz=2.5mm
 Reference Value = 66.2 V/m; Power Drift = -0.078 dB
 Peak SAR (extrapolated) = 30.8 W/kg
SAR(1 g) = 8.33 mW/g; SAR(10 g) = 2.4 mW/g
 Maximum value of SAR (measured) = 16 mW/g

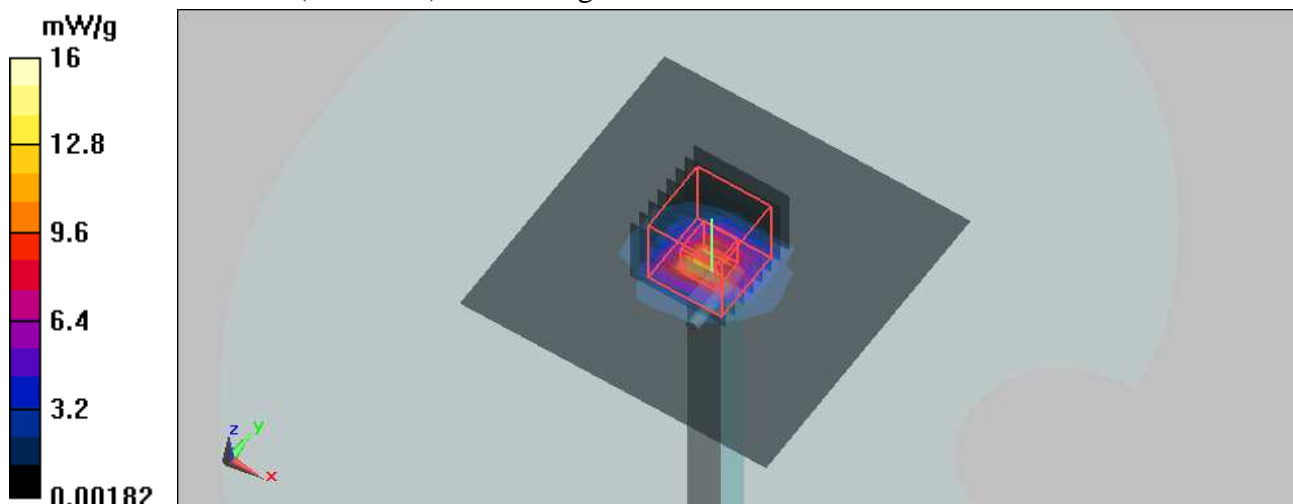

Test Laboratory: Bureau Veritas ADT

System Performance Check-HSL5500MHz 4-16

DUT: Dipole D5GHzV2 ; Type: D5GHzV2 ; Serial: 1018 ; Test Frequency: 5500 MHz

Communication System: CW-5GHz ; Frequency: 5500 MHz; Duty Cycle: 1:1; Modulation type: CW
 Medium: HSL5800; Medium parameters used: $f = 5500$ MHz; $\sigma = 5.02$ mho/m; $\epsilon_r = 36.4$; $\rho = 1000$ kg/m³ ;
 Liquid level : 153 mm

Phantom section: Flat Section ; Separation distance : 10 mm (The feetpoint of the dipole to the Phantom) Air temp. : 23.3 degrees ; Liquid temp. : 23.0 degrees

DASY5 Configuration:

- Probe: EX3DV3 - SN3504; ConvF(4.51, 4.51, 4.51); Calibrated: 2010/1/26
- Sensor-Surface: 2mm (Mechanical Surface Detection)
- Electronics: DAE3 Sn510; Calibrated: 2009/12/16
- Phantom: SAM with CRP; Type: SAM; Serial: TP-1485
- Measurement SW: DASY5, V5.2 Build 157; SEMCAD X Version 14.0 Build 57

System Performance Check with D5GHzV2 Dipole (uniform grid)/d=10mm, Pin=100mW, f=5500 MHz/Area Scan (10x10x1): Measurement grid: dx=10mm, dy=10mm
 Maximum value of SAR (measured) = 11.6 mW/g

System Performance Check with D5GHzV2 Dipole (uniform grid)/d=10mm, Pin=100mW, f=5500 MHz/Zoom Scan (4x4x2.5mm), dist=2mm (8x8x10)/Cube 0:
 Measurement grid: dx=4mm, dy=4mm, dz=2.5mm
 Reference Value = 66.2 V/m; Power Drift = 0.019 dB
 Peak SAR (extrapolated) = 33.5 W/kg
SAR(1 g) = 8.69 mW/g; SAR(10 g) = 2.46 mW/g
 Maximum value of SAR (measured) = 17 mW/g

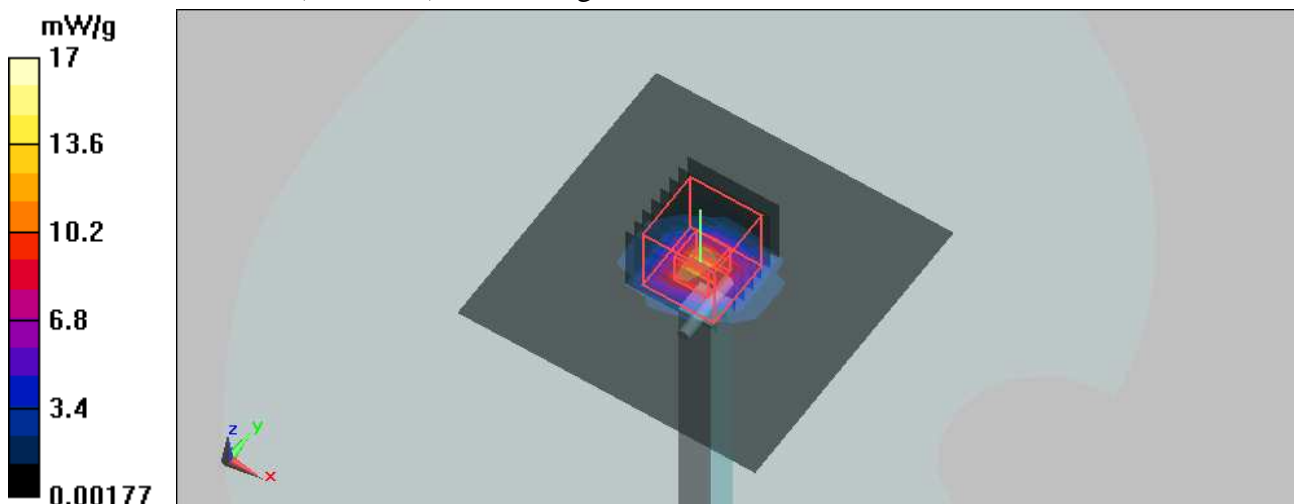

Test Laboratory: Bureau Veritas ADT

System Performance Check-HSL5200MHz 4-17

DUT: Dipole D5GHzV2 ; Type: D5GHzV2 ; Serial: 1018 ; Test Frequency: 5200 MHz

Communication System: CW-5GHz ; Frequency: 5200 MHz; Duty Cycle: 1:1; Modulation type: CW
 Medium: HSL5800; Medium parameters used: $f = 5200$ MHz; $\sigma = 4.66$ mho/m; $\epsilon_r = 36.9$; $\rho = 1000$ kg/m³ ;
 Liquid level : 152 mm
 Phantom section: Flat Section ; Separation distance : 10 mm (The feetpoint of the dipole to the Phantom)
 Air temp. : 23.3 degrees ; Liquid temp. : 22.9 degrees

DASY5 Configuration:

- Probe: EX3DV3 - SN3504; ConvF(4.87, 4.87, 4.87); Calibrated: 2010/1/26
- Sensor-Surface: 2mm (Mechanical Surface Detection)
- Electronics: DAE3 Sn510; Calibrated: 2009/12/16
- Phantom: SAM with CRP; Type: SAM; Serial: TP-1485
- Measurement SW: DASY5, V5.2 Build 157; SEMCAD X Version 14.0 Build 57

System Performance Check with D5GHzV2 Dipole (uniform grid)/d=10mm, Pin=100mW, f=5200 MHz/Area Scan (10x10x1): Measurement grid: dx=10mm, dy=10mm
 Maximum value of SAR (measured) = 12 mW/g

System Performance Check with D5GHzV2 Dipole (uniform grid)/d=10mm, Pin=100mW, f=5200 MHz/Zoom Scan (4x4x2.5mm), dist=2mm (8x8x10)/Cube 0:
 Measurement grid: dx=4mm, dy=4mm, dz=2.5mm
 Reference Value = 65.4 V/m; Power Drift = 0.040 dB
 Peak SAR (extrapolated) = 30.7 W/kg
SAR(1 g) = 8.29 mW/g; SAR(10 g) = 2.39 mW/g
 Maximum value of SAR (measured) = 15.8 mW/g

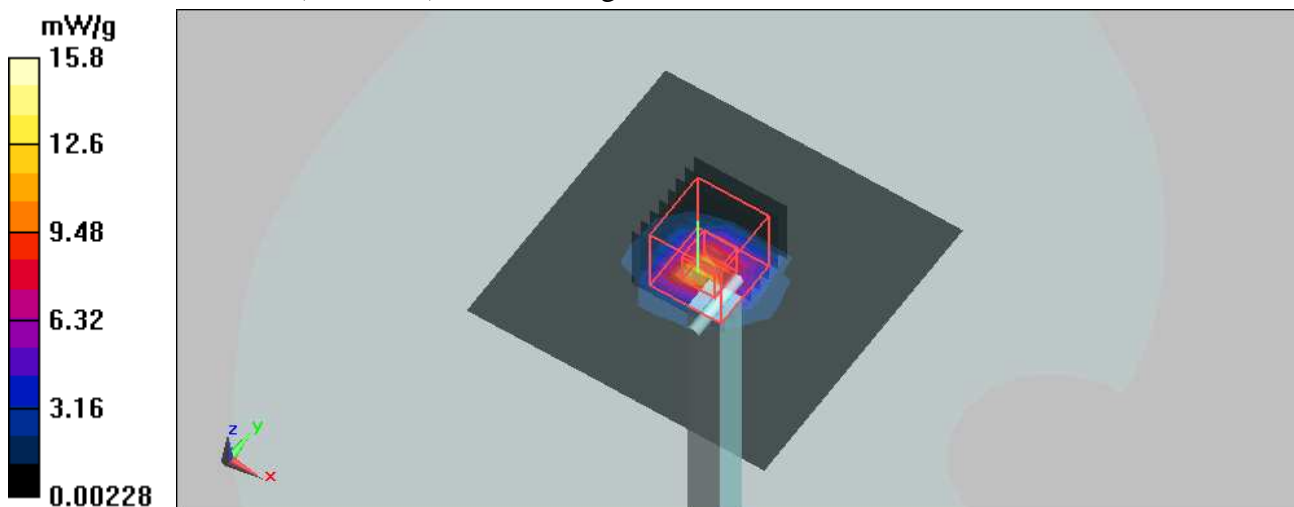

Test Laboratory: Bureau Veritas ADT

System Performance Check- HSL5500MHz 4-17

DUT: Dipole D5GHzV2 ; Type: D5GHzV2 ; Serial: 1018 ; Test Frequency: 5500 MHz

Communication System: CW-5GHz ; Frequency: 5500 MHz; Duty Cycle: 1:1; Modulation type: CW
 Medium: HSL5800; Medium parameters used: $f = 5500$ MHz; $\sigma = 5.02$ mho/m; $\epsilon_r = 36.3$; $\rho = 1000$ kg/m³ ;
 Liquid level : 152 mm

Phantom section: Flat Section ; Separation distance : 10 mm (The feetpoint of the dipole to the Phantom) Air temp. : 23.3 degrees ; Liquid temp. : 22.9 degrees

DASY5 Configuration:

- Probe: EX3DV3 - SN3504; ConvF(4.51, 4.51, 4.51); Calibrated: 2010/1/26
- Sensor-Surface: 2mm (Mechanical Surface Detection)
- Electronics: DAE3 Sn510; Calibrated: 2009/12/16
- Phantom: SAM with CRP; Type: SAM; Serial: TP-1485
- Measurement SW: DASY5, V5.2 Build 157; SEMCAD X Version 14.0 Build 57

System Performance Check with D5GHzV2 Dipole (uniform grid)/d=10mm, Pin=100mW, f=5500 MHz/Area Scan (10x10x1): Measurement grid: dx=10mm, dy=10mm
 Maximum value of SAR (measured) = 11.7 mW/g

System Performance Check with D5GHzV2 Dipole (uniform grid)/d=10mm, Pin=100mW, f=5500 MHz/Zoom Scan (4x4x2.5mm), dist=2mm (8x8x10)/Cube 0:

Measurement grid: dx=4mm, dy=4mm, dz=2.5mm
 Reference Value = 66.1 V/m; Power Drift = 0.063 dB
 Peak SAR (extrapolated) = 33.6 W/kg
SAR(1 g) = 8.7 mW/g; SAR(10 g) = 2.47 mW/g
 Maximum value of SAR (measured) = 17 mW/g

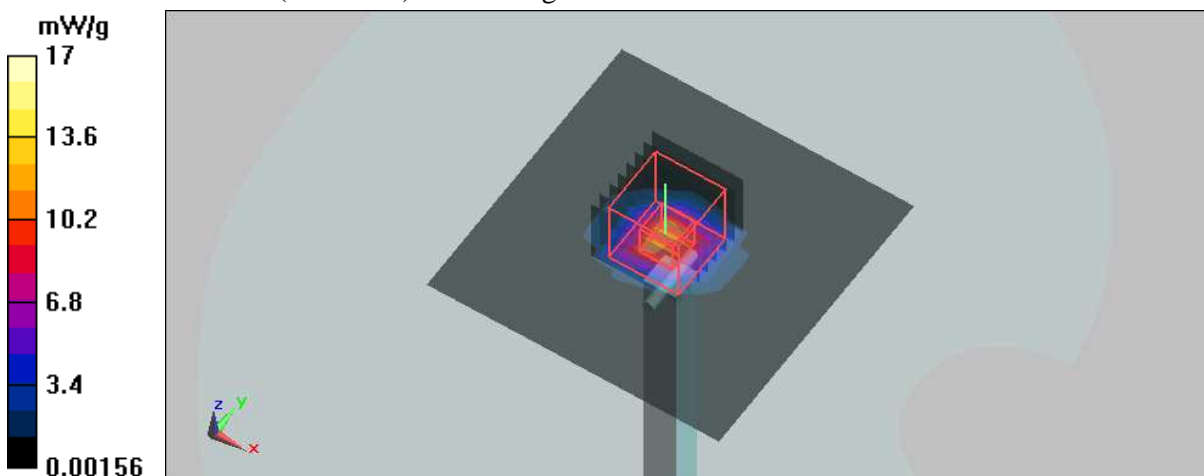

Test Laboratory: Bureau Veritas ADT

System Performance Check-HSL 5200MHz 4-18

DUT: Dipole D5GHzV2 ; Type: D5GHzV2 ; Serial: 1018 ; Test Frequency: 5200 MHz

Communication System: CW-5GHz ; Frequency: 5200 MHz; Duty Cycle: 1:1; Modulation type: CW
 Medium: HSL5800; Medium parameters used: $f = 5200$ MHz; $\sigma = 4.61$ mho/m; $\epsilon_r = 36.5$; $\rho = 1000$ kg/m³ ;
 Liquid level : 152 mm
 Phantom section: Flat Section ; Separation distance : 10 mm (The feetpoint of the dipole to the Phantom)
 Air temp. : 23.0 degrees ; Liquid temp. : 22.5 degrees

DASY5 Configuration:

- Probe: EX3DV3 - SN3504; ConvF(4.87, 4.87, 4.87); Calibrated: 2010/1/26
- Sensor-Surface: 2mm (Mechanical Surface Detection)
- Electronics: DAE3 Sn510; Calibrated: 2009/12/16
- Phantom: SAM with CRP; Type: SAM; Serial: TP-1485
- Measurement SW: DASY5, V5.2 Build 157; SEMCAD X Version 14.0 Build 57

System Performance Check with D5GHzV2 Dipole (uniform grid)/d=10mm, Pin=100mW, f=5200 MHz/Area Scan (10x10x1): Measurement grid: dx=10mm, dy=10mm
 Maximum value of SAR (measured) = 11.9 mW/g

System Performance Check with D5GHzV2 Dipole (uniform grid)/d=10mm, Pin=100mW, f=5200 MHz/Zoom Scan (4x4x2.5mm), dist=2mm (8x8x10)/Cube 0:
 Measurement grid: dx=4mm, dy=4mm, dz=2.5mm
 Reference Value = 66.2 V/m; Power Drift = -0.08 dB
 Peak SAR (extrapolated) = 30.7 W/kg
SAR(1 g) = 8.29 mW/g; SAR(10 g) = 2.39 mW/g
 Maximum value of SAR (measured) = 15.9 mW/g

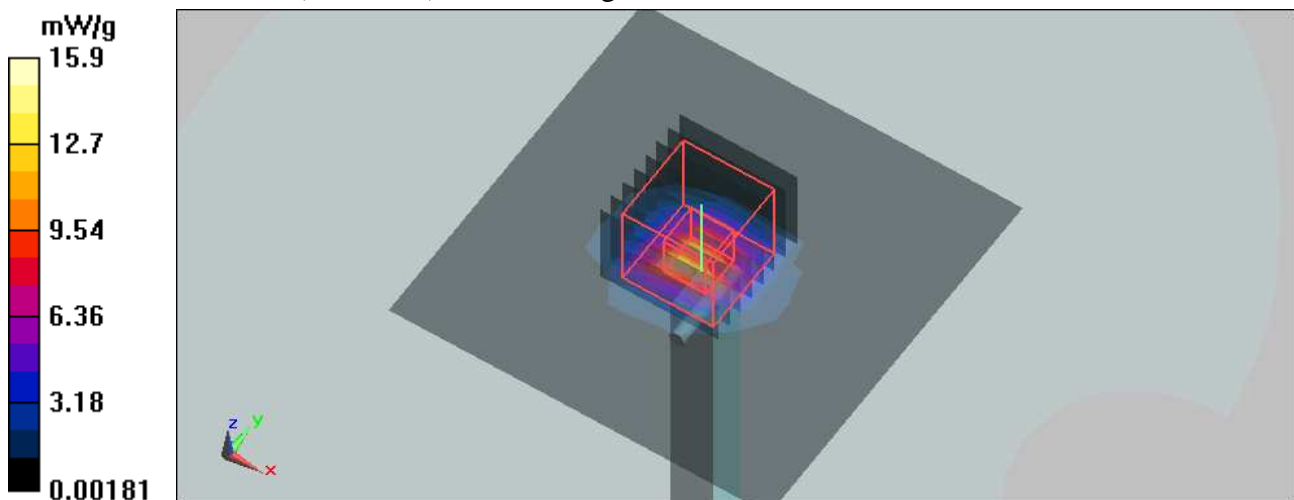

Test Laboratory: Bureau Veritas ADT

System Performance Check- HSL 5500MHz 4-18

DUT: Dipole D5GHzV2 ; Type: D5GHzV2 ; Serial: 1018 ; Test Frequency: 5500 MHz

Communication System: CW-5GHz ; Frequency: 5500 MHz; Duty Cycle: 1:1; Modulation type: CW
 Medium: HSL5800; Medium parameters used: $f = 5500$ MHz; $\sigma = 4.96$ mho/m; $\epsilon_r = 36.1$; $\rho = 1000$ kg/m³ ;
 Liquid level : 152 mm
 Phantom section: Flat Section ; Separation distance : 10 mm (The feetpoint of the dipole to the Phantom) Air temp. : 23.0 degrees ; Liquid temp. : 22.5 degrees

DASY5 Configuration:

- Probe: EX3DV3 - SN3504; ConvF(4.51, 4.51, 4.51); Calibrated: 2010/1/26
- Sensor-Surface: 2mm (Mechanical Surface Detection)
- Electronics: DAE3 Sn510; Calibrated: 2009/12/16
- Phantom: SAM with CRP; Type: SAM; Serial: TP-1485
- Measurement SW: DASY5, V5.2 Build 157; SEMCAD X Version 14.0 Build 57

System Performance Check with D5GHzV2 Dipole (uniform grid)/d=10mm, Pin=100mW, f=5500 MHz/Area Scan (10x10x1): Measurement grid: dx=10mm, dy=10mm
 Maximum value of SAR (measured) = 11.5 mW/g

System Performance Check with D5GHzV2 Dipole (uniform grid)/d=10mm, Pin=100mW, f=5500 MHz/Zoom Scan (4x4x2.5mm), dist=2mm (8x8x10)/Cube 0:
 Measurement grid: dx=4mm, dy=4mm, dz=2.5mm
 Reference Value = 66.2 V/m; Power Drift = 0.026 dB
 Peak SAR (extrapolated) = 33.3 W/kg
SAR(1 g) = 8.64 mW/g; SAR(10 g) = 2.44 mW/g
 Maximum value of SAR (measured) = 16.8 mW/g

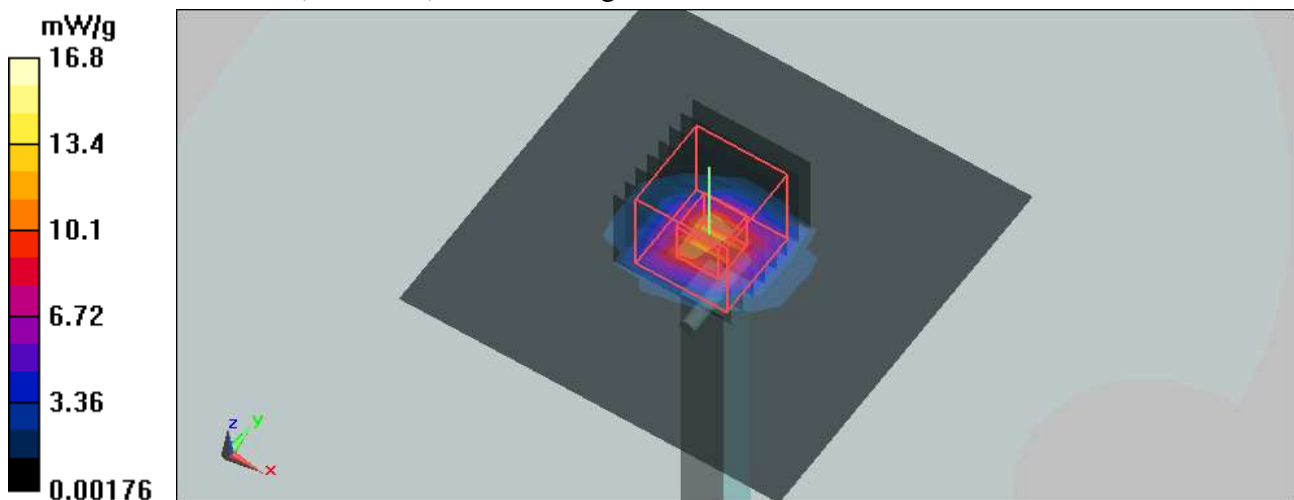

Test Laboratory: Bureau Veritas ADT

System Performance Check- HSL 5200MHz 4-19

DUT: Dipole D5GHzV2 ; Type: D5GHzV2 ; Serial: 1018 ; Test Frequency: 5200 MHz

Communication System: CW-5GHz ; Frequency: 5200 MHz; Duty Cycle: 1:1; Modulation type: CW
 Medium: HSL5800; Medium parameters used: $f = 5200$ MHz; $\sigma = 4.66$ mho/m; $\epsilon_r = 36.9$; $\rho = 1000$ kg/m³ ;
 Liquid level : 152 mm
 Phantom section: Flat Section ; Separation distance : 10 mm (The feetpoint of the dipole to the Phantom)
 Air temp. : 23.1 degrees ; Liquid temp. : 22.6 degrees

DASY5 Configuration:

- Probe: EX3DV3 - SN3504; ConvF(4.87, 4.87, 4.87); Calibrated: 2010/1/26
- Sensor-Surface: 2mm (Mechanical Surface Detection)
- Electronics: DAE3 Sn510; Calibrated: 2009/12/16
- Phantom: SAM with CRP; Type: SAM; Serial: TP-1485
- Measurement SW: DASY5, V5.2 Build 157; SEMCAD X Version 14.0 Build 57

System Performance Check with D5GHzV2 Dipole (uniform grid)/d=10mm, Pin=100mW, f=5200 MHz/Area Scan (10x10x1): Measurement grid: dx=10mm, dy=10mm
 Maximum value of SAR (measured) = 12 mW/g

System Performance Check with D5GHzV2 Dipole (uniform grid)/d=10mm, Pin=100mW, f=5200 MHz/Zoom Scan (4x4x2.5mm), dist=2mm (8x8x10)/Cube 0:
 Measurement grid: dx=4mm, dy=4mm, dz=2.5mm
 Reference Value = 66.7 V/m; Power Drift = -0.072 dB
 Peak SAR (extrapolated) = 31 W/kg
SAR(1 g) = 8.37 mW/g; SAR(10 g) = 2.41 mW/g
 Maximum value of SAR (measured) = 16 mW/g

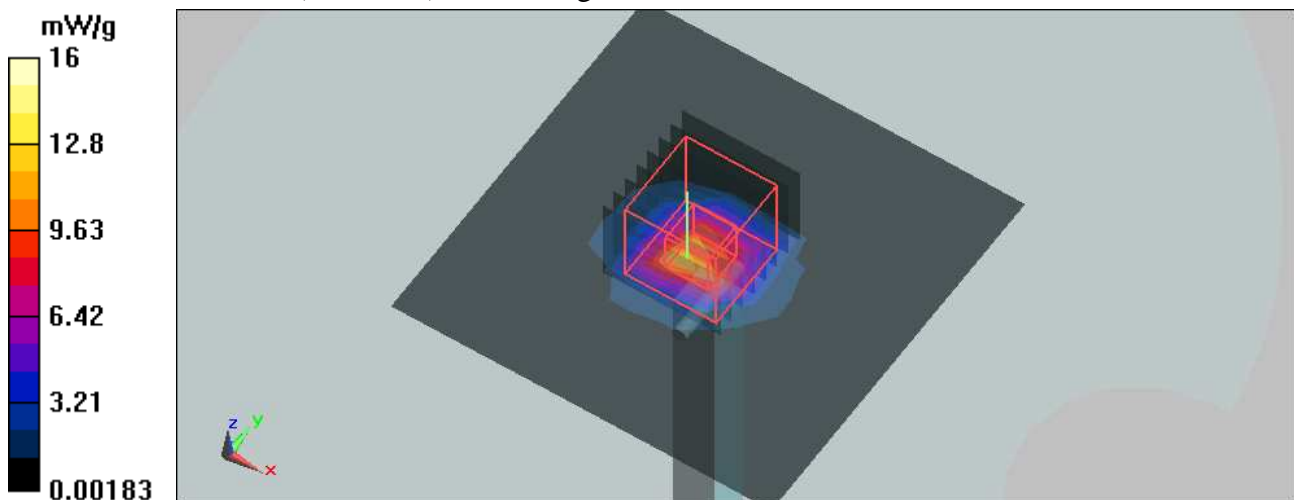

Test Laboratory: Bureau Veritas ADT

System Performance Check- HSL 5500MHz 4-19

DUT: Dipole D5GHzV2 ; Type: D5GHzV2 ; Serial: 1018 ; Test Frequency: 5500 MHz

Communication System: CW-5GHz ; Frequency: 5500 MHz; Duty Cycle: 1:1; Modulation type: CW
 Medium: HSL5800;Medium parameters used: $f = 5500$ MHz; $\sigma = 5.02$ mho/m; $\epsilon_r = 36.3$; $\rho = 1000$ kg/m³ ;
 Liquid level : 152 mm
 Phantom section: Flat Section ; Separation distance : 10 mm (The feetpoint of the dipole to the Phantom)Air temp. : 23.1 degrees ; Liquid temp. : 22.6 degrees

DASY5 Configuration:

- Probe: EX3DV3 - SN3504; ConvF(4.51, 4.51, 4.51); Calibrated: 2010/1/26
- Sensor-Surface: 2mm (Mechanical Surface Detection)
- Electronics: DAE3 Sn510; Calibrated: 2009/12/16
- Phantom: SAM with CRP; Type: SAM; Serial: TP-1485
- Measurement SW: DASY5, V5.2 Build 157; SEMCAD X Version 14.0 Build 57

System Performance Check with D5GHzV2 Dipole (uniform grid)/d=10mm, Pin=100mW, f=5500 MHz/Area Scan (10x10x1): Measurement grid: dx=10mm, dy=10mm
 Maximum value of SAR (measured) = 11.7 mW/g

System Performance Check with D5GHzV2 Dipole (uniform grid)/d=10mm, Pin=100mW, f=5500 MHz/Zoom Scan (4x4x2.5mm), dist=2mm (8x8x10)/Cube 0:
 Measurement grid: dx=4mm, dy=4mm, dz=2.5mm
 Reference Value = 66.5 V/m; Power Drift = 0.023 dB
 Peak SAR (extrapolated) = 33.7 W/kg
SAR(1 g) = 8.74 mW/g; SAR(10 g) = 2.47 mW/g
 Maximum value of SAR (measured) = 17.1 mW/g

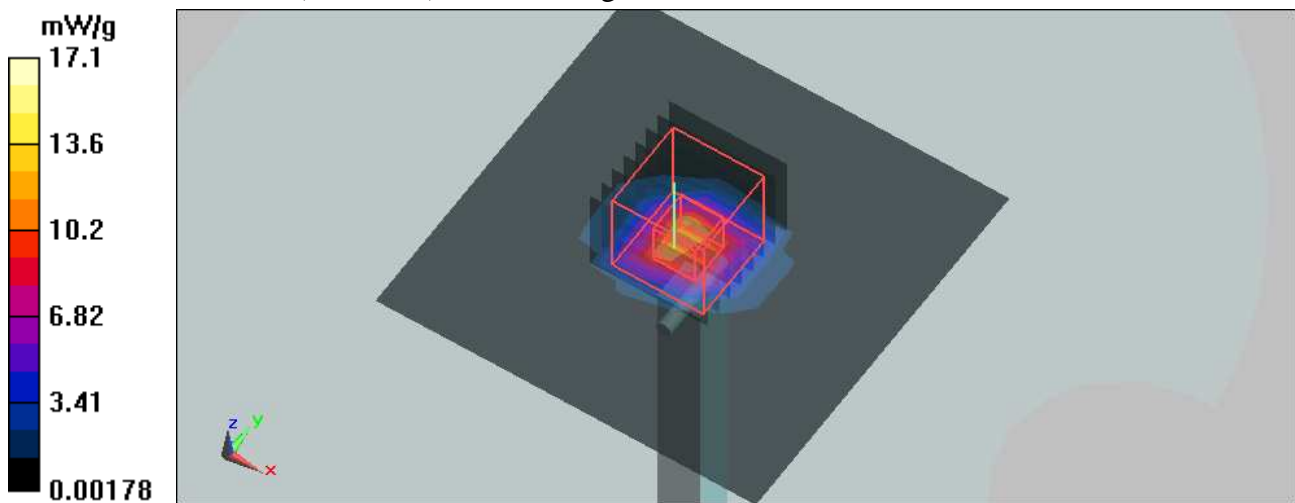

Test Laboratory: Bureau Veritas ADT

System Performance Check- MSL 5200MHz 4-20

DUT: Dipole D5GHzV2 ; Type: D5GHzV2 ; Serial: 1018 ; Test Frequency: 5200 MHz

Communication System: CW-5GHz ; Frequency: 5200 MHz; Duty Cycle: 1:1; Modulation type: CW
 Medium: MSL5800; Medium parameters used: $f = 5200$ MHz; $\sigma = 5.37$ mho/m; $\epsilon_r = 51.4$; $\rho = 1000$ kg/m³ ; Liquid level : 154 mm

Phantom section: Flat Section ; Separation distance : 10 mm (The feetpoint of the dipole to the Phantom) Air temp. : 23.0 degrees ; Liquid temp. : 22.5 degrees

DASY5 Configuration:

- Probe: EX3DV3 - SN3504; ConvF(4.45, 4.45, 4.45); Calibrated: 2010/1/26
- Sensor-Surface: 2mm (Mechanical Surface Detection)
- Electronics: DAE3 Sn510; Calibrated: 2009/12/16
- Phantom: SAM with CRP; Type: SAM; Serial: TP-1485
- Measurement SW: DASY5, V5.2 Build 157; SEMCAD X Version 14.0 Build 57

System Performance Check with D5GHzV2 Dipole (uniform grid)/d=10mm, Pin=100mW, f=5200 MHz/Area Scan (10x10x1): Measurement grid: dx=10mm, dy=10mm
 Maximum value of SAR (measured) = 11.2 mW/g

System Performance Check with D5GHzV2 Dipole (uniform grid)/d=10mm, Pin=100mW, f=5200 MHz/Zoom Scan (4x4x2.5mm), dist=2mm (8x8x10)/Cube 0:
 Measurement grid: dx=4mm, dy=4mm, dz=2.5mm
 Reference Value = 69.2 V/m; Power Drift = -0.078 dB
 Peak SAR (extrapolated) = 28.2 W/kg
SAR(1 g) = 7.89 mW/g; SAR(10 g) = 2.28 mW/g
 Maximum value of SAR (measured) = 15.1 mW/g

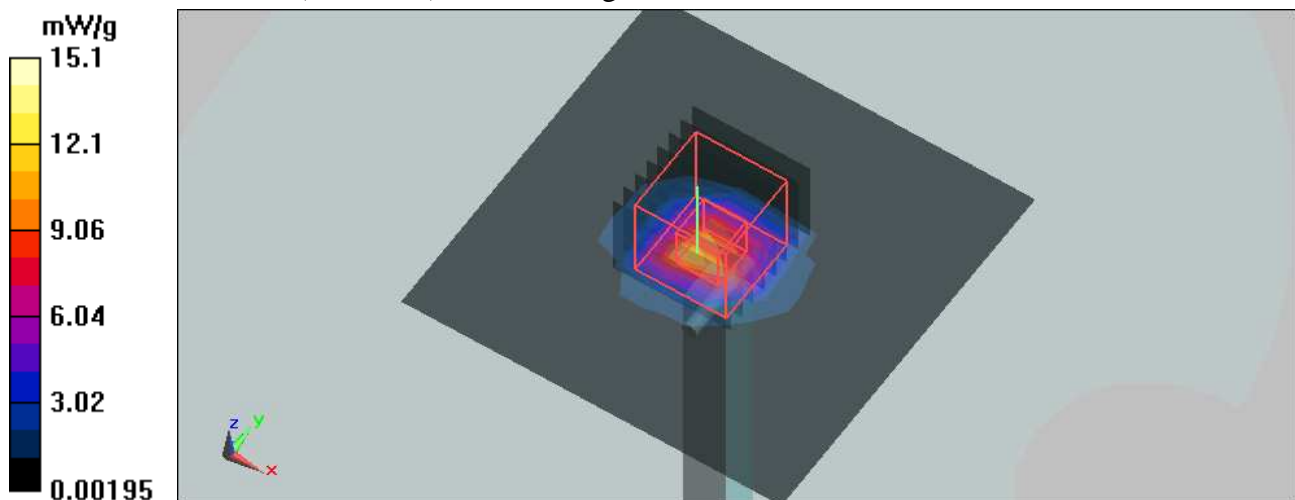

Test Laboratory: Bureau Veritas ADT

System Performance Check- MSL 5500MHz 4-20

DUT: Dipole D5GHzV2 ; Type: D5GHzV2 ; Serial: 1018 ; Test Frequency: 5500 MHz

Communication System: CW-5GHz ; Frequency: 5500 MHz; Duty Cycle: 1:1; Modulation type: CW
 Medium: MSL5800; Medium parameters used: $f = 5500$ MHz; $\sigma = 5.79$ mho/m; $\epsilon_r = 50.9$; $\rho = 1000$ kg/m³ ; Liquid level : 154 mm

Phantom section: Flat Section ; Separation distance : 10 mm (The feetpoint of the dipole to the Phantom) Air temp. : 23.0 degrees ; Liquid temp. : 22.5 degrees

DASY5 Configuration:

- Probe: EX3DV3 - SN3504; ConvF(3.91, 3.91, 3.91); Calibrated: 2010/1/26
- Sensor-Surface: 2mm (Mechanical Surface Detection)
- Electronics: DAE3 Sn510; Calibrated: 2009/12/16
- Phantom: SAM with CRP; Type: SAM; Serial: TP-1485
- Measurement SW: DASY5, V5.2 Build 157; SEMCAD X Version 14.0 Build 57

System Performance Check with D5GHzV2 Dipole (uniform grid)/d=10mm, Pin=100mW, f=5500 MHz/Area Scan (10x10x1): Measurement grid: dx=10mm, dy=10mm
 Maximum value of SAR (measured) = 11.4 mW/g

System Performance Check with D5GHzV2 Dipole (uniform grid)/d=10mm, Pin=100mW, f=5500 MHz/Zoom Scan (4x4x2.5mm), dist=2mm (8x8x10)/Cube 0:
 Measurement grid: dx=4mm, dy=4mm, dz=2.5mm
 Reference Value = 71 V/m; Power Drift = 0.019 dB
 Peak SAR (extrapolated) = 30.9 W/kg
SAR(1 g) = 8.56 mW/g; SAR(10 g) = 2.43 mW/g
 Maximum value of SAR (measured) = 16.6 mW/g

