



SAR TEST REPORT (CO-LOCATED)

REPORT NO.: SA970123L04-1

MODEL NO.: MC7596

RECEIVED: Jan. 23, 2008

TESTED: Feb. 01 ~ Feb. 09, 2008

ISSUED: Feb. 29, 2008

APPLICANT: Symbol Technologies, Inc.

ADDRESS: One Symbol Plaza, Holtsville, NY 11742-1300 USA

ISSUED BY: Advance Data Technology Corporation

LAB ADDRESS: No. 47, 14th Ling, Chia Pau Tsuen, Lin Kou Hsiang
244, Taipei Hsien, Taiwan, R.O.C.

TEST LOCATION: No. 19, Hwa Ya 2nd Rd., Wen Hwa Tsuen, Kwei Shan
Hsiang, Taoyuan Hsien 333, Taiwan, R.O.C.

This test report consists of 41 pages in total except Appendix. It may be duplicated completely for legal use with the approval of the applicant. It should not be reproduced except in full, without the written approval of our laboratory. The client should not use it to claim product endorsement by TAF, A2LA or any government agencies. The test results in the report only apply to the tested sample.





TABLE OF CONTENTS

1.	CERTIFICATION.....	3
2.	GENERAL INFORMATION	4
2.1	GENERAL DESCRIPTION OF EUT	4
2.2	SAR MEASUREMENT CONDITIONS FOR WCDMA	8
2.3	GENERAL DESCRIPTION OF APPLIED STANDARDS	10
2.4	GENERAL INFORMATION OF THE SAR SYSTEM	11
2.5	GENERAL DESCRIPTION OF THE SPATIAL PEAK SAR EVALUATION	14
3.	DESCRIPTION OF SUPPORT UNITS.....	17
4.	DESCRIPTION OF TEST POSITION.....	18
4.1	DESCRIPTION OF TEST POSITION	18
4.2.1	TOUCH/CHEEK TEST POSITION.....	19
4.2.2	TILT TEST POSITION	20
4.2.3	BODY-WORN CONFIGURATION.....	20
4.2	DESCRIPTION OF TEST MODE.....	21
4.3	SUMMARY OF TEST RESULTS	22
5.	TEST RESULTS	23
5.1	TEST PROCEDURES	23
5.2	MEASURED SAR RESULTS.....	25
6.	INFORMATION ON THE TESTING LABORATORIES	41
	APPENDIX A: TEST DATA	
	APPENDIX B: COLLOCATED SAR EVALUATION PROCEDURE	



1. CERTIFICATION

PRODUCT: EDA (Enterprise Digital Assistant)

MODEL: MC7596

BRAND: Symbol

APPLICANT: Symbol Technologies, Inc.

TESTED: Feb. 01 ~ Feb. 09, 2008

TEST SAMPLE: PROTOTYPE

STANDARDS: FCC Part 2 (Section 2.1093)

FCC OET Bulletin 65, Supplement C (01-01)

RSS-102

IEEE 1528-2003

The above equipment (model: MC7596) have been tested by **Advance Data Technology Corporation**, and found compliance with the requirement of the above standards. The test record, data evaluation & Equipment Under Test (EUT) configurations represented herein are true and accurate accounts of the measurements of the sample's EMC characteristics under the conditions specified in this report.

PREPARED BY :  , **DATE:** Mar. 03, 2008
Joanna Wang / Senior Specialist

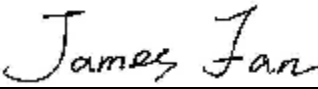
TECHNICAL ACCEPTANCE :  , **DATE:** Mar. 03, 2008
Responsible for RF James Fan / Engineer

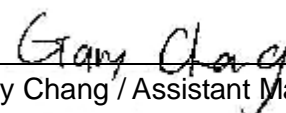
APPROVED BY :  , **DATE:** Mar. 03, 2008
Gary Chang / Assistant Manager



2. GENERAL INFORMATION

2.1 GENERAL DESCRIPTION OF EUT

PRODUCT	EDA (Enterprise Digital Assistant)
MODEL NO.	MC7596
FCC ID	H9PMC7596
POWER SUPPLY	3.7Vdc from rechargeable lithium battery 5.4Vdc from power adapter
CLASSIFICATION	Portable device, production unit
MODULATION TYPE	Mobile phone: GMSK / 8PSK / BPSK Wireless LAN: CCK, DQPSK, DBPSK for DSSS 64QAM, 16QAM, QPSK, BPSK for OFDM Bluetooth: GFSK, $\pi/4$ -DQPSK, 8DPSK GPS: C/A code
FREQUENCY RANGE	Mobile phone: Tx Frequency: 824.2MHz ~ 848.8MHz (GSM band) 1850.2MHz ~ 1909.8MHz (WCDMA band) Rx Frequency: 869.2MHz ~ 893.8MHz (GSM band) 1930.2MHz ~ 1989.8MHz (WCDMA band) Wireless LAN: 2.4GHz: 2400 ~ 2483.5MHz 5.0GHz: 5150 ~ 5350MHz & 5470 ~ 5725MHz & 5725 ~ 5850MHz Bluetooth: 2402 ~ 2480MHz GPS: 1575.42 MHz
CHANNEL FREQUENCIES UNDER TEST AND ITS CONDUCTED OUTPUT POWER	Mobile phone: GSM850 band: 1.905W / 824.2MHz for channel 128 1.950W / 836.6MHz for channel 190 1.995W / 848.8MHz for channel 251 WCDMA850 band: 0.385W / 826.4MHz for channel 4132 0.385W / 836.4MHz for channel 4182 0.393W / 846.6MHz for channel 4233

	<p>PCS1900 band: 0.933W / 1850.2MHz for channel 512 0.955W / 1880.0MHz for channel 661 0.912W / 1909.8MHz for channel 810</p> <p>WCDMA1900 band: 0.428W / 1852.4MHz for channel 9262 0.494W / 1880.0MHz for channel 9400 0.459W / 1907.6MHz for channel 9538</p>
	<p>Wireless LAN:</p> <p>802.11b: 35.97mW / Ch1: 2412MHz 36.22mW / Ch6: 2437MHz 35.89mW / Ch11: 2462MHz</p> <p>802.11g: 44.77mW / Ch1: 2412MHz 101.86mW / Ch6: 2437MHz 44.67mW / Ch11: 2462MHz</p> <p>802.11a:</p> <p>5150 ~ 5350MHz & 5470 ~ 5725MHz: 12.79mW / Ch36: 5180MHz 12.94mW / Ch40: 5200MHz 12.71mW / Ch48: 5240MHz 13.18mW / Ch52: 5260MHz 15.24mW / Ch60: 5300MHz 16.75mW / Ch64: 5320MHz 18.37mW / Ch100: 5500MHz 27.13mW / Ch104: 5520MHz 26.55mW / Ch116: 5580MHz 26.79mW / Ch120: 5600MHz 26.92mW / Ch124: 5620MHz 26.73mW / Ch136: 5680MHz 8.49mW / Ch140: 5700MHz</p> <p>5725 ~ 5850MHz: 71.45mW / Ch149: 5745MHz 80.91mW / Ch157: 5785MHz 81.28mW / Ch165: 5825MHz</p> <p>Bluetooth: 2.04mW / Ch0: 2402MHz</p>

MAX. AVERAGE SAR (1g)	Head: Mobile phone: 0.665W/kg (GSM850) 0.610W/kg (WCDMA850) 0.642W/kg (PCS1900) 0.771W/kg (WCDMA1900) Wireless LAN: 0.50800W/kg (802.11b) 0.60200W/kg (802.11g) 1.15000W/kg (802.11a: 5150 ~ 5350MHz & 5470 ~ 5725MHz) 0.95000W/kg (802.11a: 5725 ~ 5850MHz) Bluetooth: 0.00344W/kg		
	Body: Mobile phone: 0.141W/kg (GSM850) 0.045W/kg (WCDMA850) 0.040W/kg (PCS1900) 0.044W/kg (WCDMA1900) Wireless LAN: 0.00505000W/kg (802.11b) 0.00627000W/kg (802.11g) 0.11300000W/kg (802.11a: 5150 ~ 5350MHz & 5470 ~ 5725MHz) 0.07000000W/kg (802.11a: 5725 ~ 5850MHz) Bluetooth: 0.00000917W/kg		
ANTENNA TYPE(S)	Mobile: Monopole antenna Wireless LAN: Inverted F antenna Planar inverted antenna Bluetooth: Chip antenna		
MAX. ANTENNA GAIN	850MHz: 4.0dBi		1900MHz: 2.0dBi
	2.4GHz: 2.5dBi	5.0GHz: 3.5dBi	Bluetooth: -1.5dBi
DATA CABLE	Refer to NOTE		
I/O PORTS	Refer to user's manual		
ASSOCIATED DEVICES	Battery		
EUT EXTREME VOL. RANGE	3.7Vdc to 4.2Vdc		

NOTE:

1. The applicant defined the normal working voltage of the battery is from 3.7Vdc to 4.2Vdc.

2. The models as identified below are identical to each other except of the following options:

- Keypad: Numeric / QWERTY
- Barcode reader: 1D laser scanner / 2D Imager

BRAND	MODEL	DESCRIPTION
Symbol	MC7596	HSDPA 1D Numeric
Symbol	MC7596	HSDPA 2D QWERTY

**the worst case had been marked by boldface.

3. The EUT is an EDA (Enterprise Digital Assistant). The functions of EUT listed as below:

	REFERENCE REPORT
WLAN 802.11a/b/g (15.247) + Bluetooth	SA970123L04-2
WLAN 802.11a (15.407)	SA970123L04-3
GSM850 / WCDMA850	SA970123L04
PCS1900 / WCDMA1900	
Mobile + WLAN + Bluetooth (Co-located)	SA970123L04-1

4. The communicated functions of EUT listed as below:

		GSM850MHz	PCS1900MHz	WCDMA850MHz	WCDMA1900MHz	With 802.11a/b/g + Bluetooth + GPS functions
2G	GSM	√	√			
	GPRS	√	√			
	EDGE	√	√			
3G	WCDMA			√	√	
	Release 5 HSDPA			√	√	

5. The EUT has one lithium battery listed as below:

LI-LON BATTERY	
BRAND:	MOTOROLA
MODEL:	82-71364-05 Rev A
RATING:	3.7Vdc, 3600mAh

6. The following accessories are for support units only.

PRODUCT	BRAND	MODEL	DESCRIPTION
RS232 charging cable	Motorola	25-102776-01R	1.2m non-shielded cable with one core
USB charging cable	Motorola	25-102775-01R	1.5m shielded cable with one core
Headset	Motorola	50-11300-050R	VR10 headset 0.8m non-shielded cable with one core
Power Supply Adaptor	Motorola	EADP-16BB A	I/P: 100-240Vac, 50-60Hz, 0.4A O/P: 5.4Vdc, 3A 1.8m non-shielded cable without core
Holster	Motorola	SG-MC7011110-01R	Ridged holster

7. Hardware version: 1c.

8. Software version: BSP16.

9. IMEI Code: 00440168000 000 ~ 00440168000 999.

10. The above EUT information was declared by manufacturer and for more detailed features description, please refer to the manufacturer's specifications or User's Manual.

2.2 SAR MEASUREMENT CONDITIONS FOR WCDMA

The following procedures were followed according to FCC “SAR Measurement Procedure for 3G Devices”, October 2007.

Ø Output Power Verification

Maximum output power is verified on the High, Middle and Low channels according to the procedures described in section 5.2 of 3GPP TS 34.121, using the appropriate RMC or AMR with TPC (transmit power control) set to all “1” s” for WCDMA/HSDPA or applying the required inner loop power control procedures to maintain maximum output power while HSUPA is active. Results for all applicable physical channel configurations (DPCCH, DPDCHn and spreading codes, HSDPA, HSPA) should be tabulated in the SAR report. All configurations that are not supported by the DUT or cannot be measured due to technical or equipment limitations should be clearly identified.

Ø Head SAR Measurement

SAR for head exposure configurations in voice mode is measured using a 12.2 kbps RMC with TPC bits configured to all “1” s” . SAR in AMR configurations is not required when the maximum average output of each RF channel for 12.2 kbps AMR is less than $\frac{1}{4}$ dB higher than that measured in 12.2 kbps RMC. Otherwise, SAR is measured on the maximum output channel in 12.2 kbps AMR with a 3.4 kbps SRB (signaling radio bearer) using the exposure configuration that results in the highest SAR in 12.2 kbps RMC for that RF channel.

Ø Body SAR Measurements

SAR for body exposure configurations in voice and data modes is measured using a 12.2 kbps RMC with TPC bits configured to all “1”s. SAR for other spreading codes and multiple DPDCHn, when supported by the DUT, are not required when the maximum average output of each RF channel, for each spreading code and DPDCHn configuration, are less than ¼ dB higher than those measured in 12.2 kbps RMC. Otherwise, SAR is measured on the maximum output channel with an applicable RMC configuration for the corresponding spreading code or DPDCHn using the exposure configuration that results in the highest SAR with 12.2 kbps RMC. When more than 2 DPDCHn are supported by the DUT, it may be necessary to configure additional DPDCHn for a DUT using FTM (Factory Test Mode) or other chipset based test approaches with parameters similar to those used in 384 kbps and 768 kbps RMC.

Ø Handsets with Release 5 HSDPA

Body SAR is not required for handsets with HSDPA capabilities when the maximum average output of each RF channel with HSDPA active is less than ¼ dB higher than that measured without HSDPA using 12.2 kbps RMC and the maximum SAR for 12.2 kbps RMC is $\leq 75\%$ of the SAR limit. Otherwise, SAR is measured for HSDPA, using the additional body SAR procedures in the “Release 5 HSDPA Data Devices” section of this document, on the maximum output channel with the body exposure configuration that results in the highest SAR in 12.2 kbps RMC for that RF channel. Handsets with both HSDPA and HSUPA should be tested according to Release 6 HSPA test procedures.



2.3 GENERAL DESCRIPTION OF APPLIED STANDARDS

According to the specifications of the manufacturer, this product must comply with the requirements of the following standards:

FCC 47 CFR Part 2 (2.1093)

FCC OET Bulletin 65, Supplement C (01- 01)

RSS-102

IEEE 1528-2003

All test items have been performed and recorded as per the above standards.



2.4 GENERAL INFORMATION OF THE SAR SYSTEM

DASY4 (software 4.7 Build 53) consists of high precision robot, probe alignment sensor, phantom, robot controller, controlled measurement server and near-field probe. The robot includes six axes that can move to the precision position of the DASY4 software defined. The DASY4 software can define the area that is detected by the probe. The robot is connected to controlled box. Controlled measurement server is connected to the controlled robot box. The DAE includes amplifier, signal multiplexing, AD converter, offset measurement and surface detection. It is connected to the Electro-optical coupler (ECO). The ECO performs the conversion from the optical into digital electric signal of the DAE and transfers data to the PC.

ET3DV6 ISOTROPIC E-FIELD PROBE

CONSTRUCTION	Symmetrical design with triangular core. Built-in optical fiber for surface detection system. Built-in shielding against static charges. PEEK enclosure material (resistant to organic solvents, e.g., glycoether).
FREQUENCY	10MHz to 3GHz; Linearity: ± 0.2 dB (30MHz to 3GHz)
DYNAMIC RANGE	5 μ W/g to > 100mW/g; Linearity: ± 0.2 dB
OPTICAL SURFACE DETECTION	± 0.2 mm repeatability in air and clear liquids over diffuse reflecting surfaces
DIMENSIONS	Overall length: 330mm (Tip Length: 16mm) Tip diameter: 6.8mm (Body diameter: 12mm) Distance from probe tip to dipole centers: 2.7mm
APPLICATION	General dosimetric measurements up to 3GHz Compliance tests of mobile phones Fast automatic scanning in arbitrary phantoms (ET3DV6)

NOTE

1. The Probe parameters have been calibrated by the SPEAG. Please reference "APPENDIX D" for the Calibration Certification Report.
2. For frequencies above 800MHz, calibration in a rectangular wave-guide is used, because wave-guide size is manageable.
3. For frequencies below 800MHz, temperature transfer calibration is used because the wave-guide size becomes relatively large.



EX3DV3 ISOTROPIC E-FIELD PROBE (FREQUENCY BAND 5 ~ 6GHz)

DIMENSIONS	Overall length: 330 mm (Tip Length: 20 mm) Tip diameter: 2.5 mm (Body diameter: 12 mm) Distance from probe tip to dipole centers: 1.0 mm
APPLICATION	General dosimetric measurements range 5 ~ 6 GHz. Fast automatic scanning in arbitrary phantoms (EX3DV3)

NOTE

4. The Probe parameters have been calibrated by the SPEAG. Please reference "APPENDIX D" for the Calibration Certification Report.
5. For frequencies above 800 MHz, calibration in a rectangular wave-guide is used, because wave-guide size is manageable.
6. For frequencies below 800 MHz, temperature transfer calibration is used because the wave-guide size becomes relatively large.

TWIN SAM V4.0

CONSTRUCTION The shell corresponds to the specifications of the Specific Anthropomorphic Mannequin (SAM) phantom defined in IEEE 1528-2003, CENELEC 50361 and IEC 62209. It enables the dosimetric evaluation of left and right hand phone usage as well as body mounted usage at the flat phantom region. A cover prevents evaporation of the liquid. Reference markings on the phantom allow the complete setup of all predefined phantom positions and measurement grids by manually teaching three points with the robot.

SHELL THICKNESS 2 ± 0.2 mm

FILLING VOLUME Approx. 25 liters

DIMENSIONS Height: 810 mm; Length: 1000 mm; Width: 500 mm

SYSTEM VALIDATION KITS:

CONSTRUCTION	Symmetrical dipole with 1/4 balun Enables measurement of feedpoint impedance with NWA Matched for use near flat phantoms filled with brain simulating solutions Includes distance holder and tripod adaptor
CALIBRATION	Calibrated SAR value for specified position and input power at the flat phantom in brain simulating solutions



FREQUENCY	835, 1900, 2450, 5200, 5500, 5800MHz
RETURN LOSS	> 20 dB at specified validation position
POWER CAPABILITY	> 100 W (f < 1GHz); > 40 W (f > 1GHz)
OPTIONS	Dipoles for other frequencies or solutions and other calibration conditions upon request

DEVICE HOLDER FOR SAM TWIN PHANTOM

CONSTRUCTION

The device holder for the GSM900/DCS1800/PCS1900 GSM/GPRS/CDMA Mobile Phone device is designed to cope with different positions given in the standard. It has two scales for the device rotation (with respect to the body axis) and the device inclination (with respect to the line between the ear reference points). The rotation centers for both scales is the ear reference point (ERP). Thus the device needs no repositioning when changing the angles. The holder has been made out of low-loss POM material having the following dielectric parameters: relative permittivity $\epsilon = 3$ and loss tangent $\delta = 0.02$. The amount of dielectric material has been reduced in the closest vicinity of the device, since measurements have suggested that the influence of the clamp on the test results could thus be lowered. The device holder for the portable device makes up of the polyethylene foam. The dielectric parameters of material close to the dielectric parameters of the air.

DATA ACQUISITION ELECTRONICS

CONSTRUCTION

The data acquisition electronics (DAE3) consists of a highly sensitive electrometer grade preamplifier with auto-zeroing, a channel and gain-switching multiplex, a fast 16 bit AD converter and a command decoder and control logic unit. Transmission to the measurement server is accomplished through an optical downlink for data and status information as well as an optical uplink for commands and the clock. The mechanical probe is mounting device includes two different sensor systems for frontal and sideways probe contacts. They are used for mechanical surface detection and probe collision detection. The input impedance of the DAE3 box is 200MOhm; the inputs are symmetrical and floating. Common mode rejection is above 80 dB.

2.5 GENERAL DESCRIPTION OF THE SPATIAL PEAK SAR EVALUATION

The DASY4 post-processing software (SEMCAD) automatically executes the following procedures to calculate the field units from the micro-volt readings at the probe connector. The parameters used in the evaluation are stored in the configuration modules of the software:

Probe parameters:	- Sensitivity	Norm _i , a _{i0} , a _{i1} , a _{i2}
	- Conversion factor	ConvF _i
	- Diode compression point	dcp _i
Device parameters:	- Frequency	F
	- Crest factor	Cf
Media parameters:	- Conductivity	σ
	- Density	ρ

The first step of the evaluation is a linearization of the filtered input signal to account for the compression characteristics of the detector diode. The compensation depends on the input signal, the diode type and the DC-transmission factor from the diode to the evaluation electronics. If the exciting field is pulsed, the crest factor of the signal must be known to correctly compensate for peak power. The formula for each channel can be given as:

$$V_i = U_i + U_i^2 \cdot \frac{cf}{dcp_i}$$

V _i	=compensated signal of channel i	(i = x, y, z)
U _i	=input signal of channel I	(i = x, y, z)
Cf	=crest factor of exciting field	(DASY parameter)
dcp _i	=diode compression point	(DASY parameter)

From the compensated input signals the primary field data for each channel can be evaluated:

$$\text{E-field probes: } E_i = \sqrt{\frac{V_i}{\text{Norm}_i \cdot \text{Conv}F}}$$

$$\text{H-field probes: } H_i = \sqrt{V_i} \cdot \frac{a_{i0} + a_{i1}f + a_{i2}f^2}{f}$$

V_i = compensated signal of channel i ($i = x, y, z$)

Norm_i = sensor sensitivity of channel i $\mu\text{V}/(\text{V/m})^2$ for ($i = x, y, z$)
E-field Probes

$\text{Conv}F$ = sensitivity enhancement in solution

a_{ij} = sensor sensitivity factors for H-field probes

F = carrier frequency [GHz]

E_i = electric field strength of channel i in V/m

H_i = magnetic field strength of channel i in A/m

The RSS value of the field components gives the total field strength (Hermitian magnitude):

$$E_{tot} = \sqrt{E_x^2 + E_y^2 + E_z^2}$$

The primary field data are used to calculate the derived field units.

$$SAR = E_{tot}^2 \cdot \frac{\sigma}{r \cdot 1'000}$$

SAR = local specific absorption rate in mW/g

E_{tot} = total field strength in V/m

σ = conductivity in [mho/m] or [Siemens/m]

ρ = equivalent tissue density in g/cm³



Note that the density is set to 1, to account for actual head tissue density rather than the density of the tissue simulating liquid. The entire evaluation of the spatial peak values is performed within the Post-processing engine (SEMCAD). The system always gives the maximum values for the 1 g and 10 g cubes. The algorithm to find the cube with highest averaged SAR is divided into the following stages:

1. The extraction of the measured data (grid and values) from the Zoom Scan
2. The calculation of the SAR value at every measurement point based on all stored data (A/D values and measurement parameters)
3. The generation of a high-resolution mesh within the measured volume
4. The interpolation of all measured values from the measurement grid to the high-resolution grid
5. The extrapolation of the entire 3-D field distribution to the phantom surface over the distance from sensor to surface
6. The calculation of the averaged SAR within masses of 1 g and 10 g.

The probe is calibrated at the center of the dipole sensors that is located 1 to 2.7mm away from the probe tip. During measurements, the probe stops shortly above the phantom surface, depending on the probe and the surface detecting system. Both distances are included as parameters in the probe configuration file. The software always knows exactly how far away the measured point is from the surface. As the probe cannot directly measure at the surface, the values between the deepest measured point and the surface must be extrapolated. The angle between the probe axis and the surface normal line is less than 30 degree.

In the Area Scan, the gradient of the interpolation function is evaluated to find all the extreme of the SAR distribution. The uncertainty on the locations of the extreme is less than 1/20 of the grid size. Only local maximum within -2 dB of the global maximum are searched and passed for the Cube Scan measurement. In the Cube Scan, the interpolation function is used to extrapolate the Peak SAR from the lowest measurement points to the inner phantom surface (the extrapolation distance). The uncertainty increases with the extrapolation distance. To keep the uncertainty within 1% for the 1 g and 10 g cubes, the extrapolation distance should not be larger than 5mm.



The maximum search is automatically performed after each area scan measurement. It is based on splines in two or three dimensions. The procedure can find the maximum for most SAR distributions even with relatively large grid spacing. After the area scanning measurement, the probe is automatically moved to a position at the interpolated maximum. The following scan can directly use this position for reference, e.g., for a finer resolution grid or the cube evaluations. The 1g and 10g peak evaluations are only available for the predefined cube 7 x 7 x 7 scans. The routines are verified and optimized for the grid dimensions used in these cube measurements. The measured volume of 30 x 30 x 30mm contains about 30g of tissue. The first procedure is an extrapolation (incl. boundary correction) to get the points between the lowest measured plane and the surface. The next step uses 3D interpolation to get all points within the measured volume in a 1mm grid (42875 points). In the last step, a 1g cube is placed numerically into the volume and its averaged SAR is calculated. This cube is the moved around until the highest averaged SAR is found. If the highest SAR is found at the edge of the measured volume, the system will issue a warning: higher SAR values might be found outside of the measured volume. In that case the cube measurement can be repeated, using the new interpolated maximum as the center.

3. DESCRIPTION OF SUPPORT UNITS

The EUT has been tested as an independent unit.

4. DESCRIPTION OF TEST POSITION

4.1 DESCRIPTION OF TEST POSITION

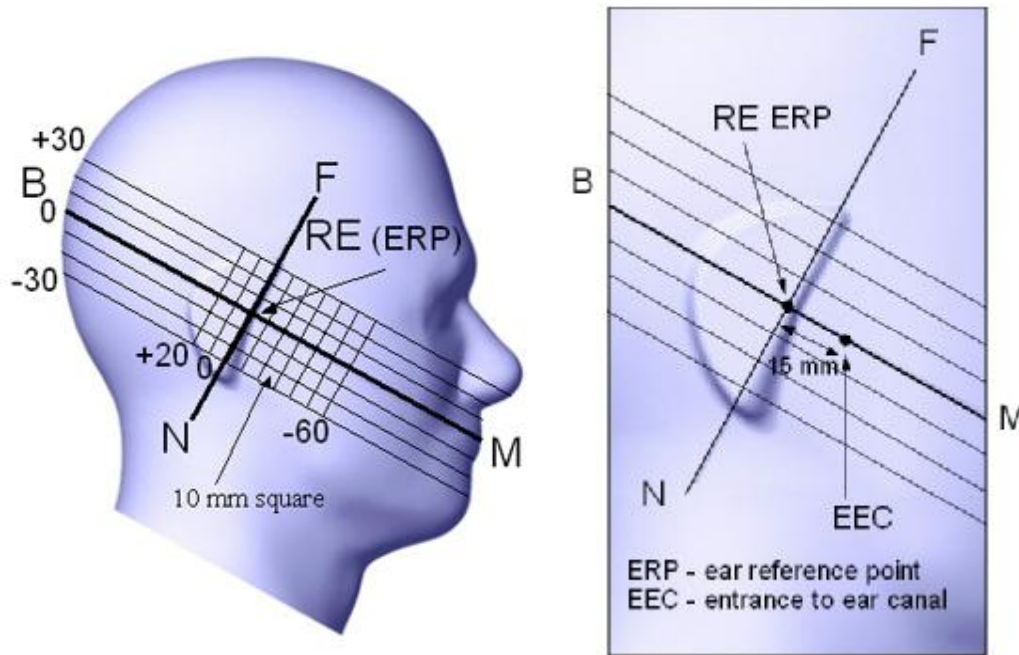

FIGURE 3.1

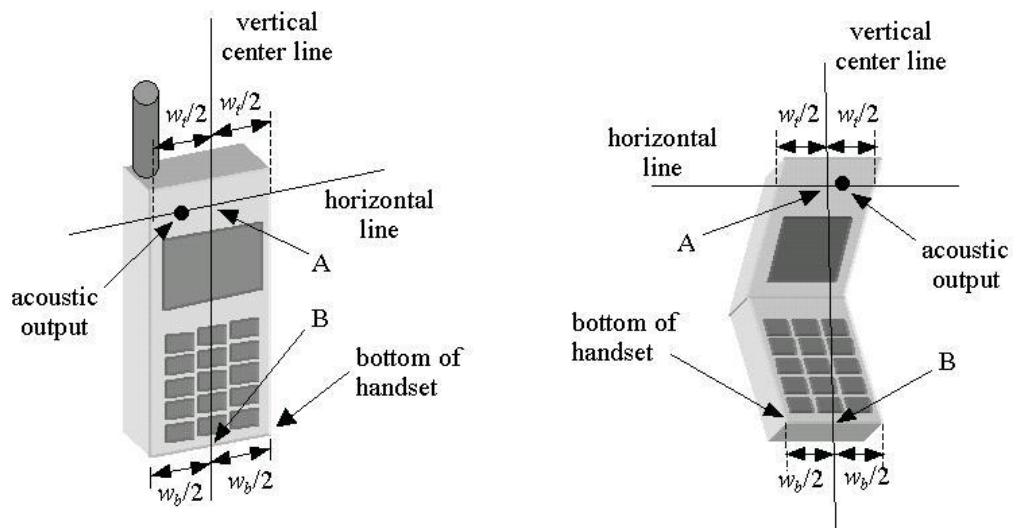
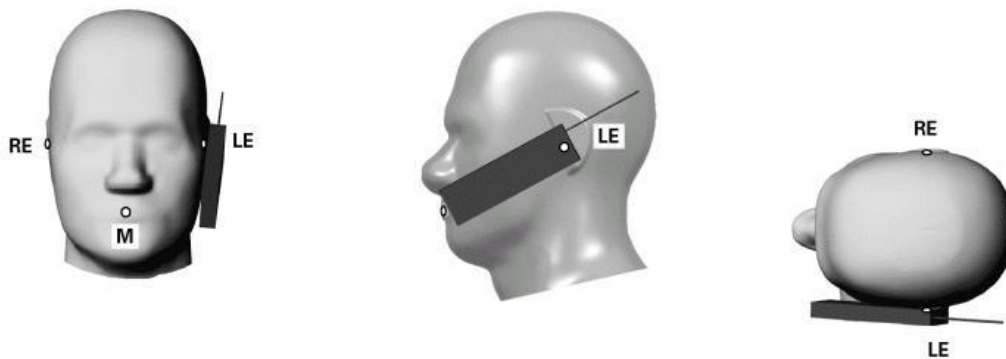

FIGURE 3.1a

FIGURE 3.1b

4.2.1 TOUCH/CHEEK TEST POSITION

The head position in Figure 3.1, the ear reference points ERP are 15mm above entrance to ear canal along the B-M line. The line N-F (Neck-Front) is perpendicular to the B-M (Back Mouth) line. The handset device in Figure 3.1a and 3.1b, The vertical centerline pass through two points on the front side of handset: the midpoint of the width w_t of the handset at the level of the acoustic output (point A) and the midpoint of the width w_b of the bottom of the handset (point B). The vertical centerline is perpendicular to the horizontal line and pass through the center of the acoustic output. The point A touches the ERP and the vertical centerline of the handset is parallel to the B-M line. While maintaining the point A contact with the ear(ERP), rotate the handset about the line NF until any point on handset is in contact with the cheek of the phantom



TOUCH/CHEEK POSITION FIGURE

4.2.2 TILT TEST POSITION

Adjust the device in the cheek position. While maintaining a point of the handset contact in the ear, move the bottom of the handset away from the mouth by an angle of 15 degrees.

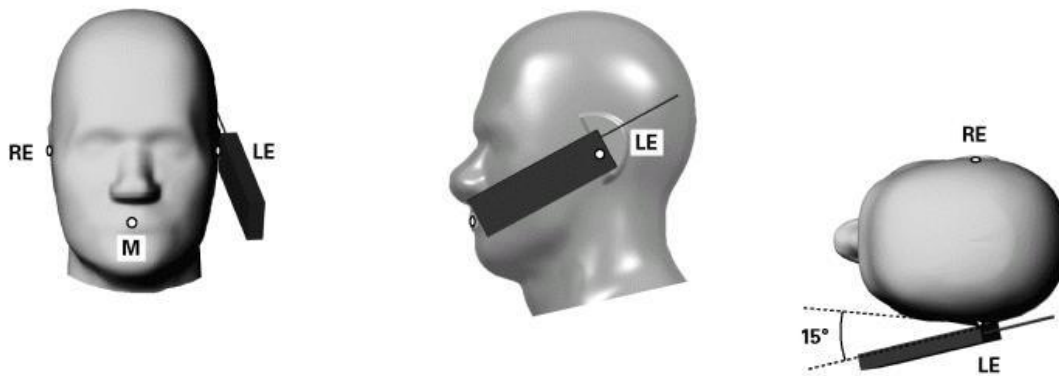

TILT POSITION FIGURE

4.2.3 BODY-WORN CONFIGURATION

The handset device attached the belt clip or the holster. The keypad face of the handset is against with the bottom of the flat phantom face and the bottom of the keypad face contact to the bottom of the flat phantom.

When multiple accessories that do not contain metallic components are supplied with the device, the device may be tested with only the accessory that dictates the closest spacing to the body. When multiple accessories that contain metallic components are supplied with the device, the device must be tested with each accessory that contains a unique metallic component. If multiple accessories share an identical metallic component (e.g., the same metallic belt-clip used with different holsters with no other metallic components), only accessory that dictates the closest spacing to the body must be tested.

4.2 DESCRIPTION OF TEST MODE

TEST MODE	COMMUNICATION MODE	MODULATION TYPE	ASSESSMENT POSITION	TESTED CHANNEL
1	GSM850+802.11g+Bluetooth	NOTE 1	B / Tilt	NOTE 1
2	WCDMA850+802.11g+Blueooth	NOTE 1	B / Tilt	NOTE 1
3	PCS1900+802.11g+Bluetooth	NOTE 1	B / Tilt	NOTE 1
4	WCDMA1900+802.11g+Bluetooth	NOTE 1	B / Tilt	NOTE 1
5	GSM850+802.11g+Bluetooth	NOTE 1	C : Body / Bottom	NOTE 1
6	WCDMA850+802.11g+Blueooth	NOTE 1	C : Body / Bottom	NOTE 1
7	PCS1900+802.11g+Bluetooth	NOTE 1	C : Body / Bottom	NOTE 1
8	WCDMA1900+802.11g+Bluetooth	NOTE 1	C : Body / Bottom	NOTE 1
9	GSM850+802.11a+Bluetooth	NOTE 1	A / Tilt	NOTE 1
10	WCDMA850+802.11a+Blueooth	NOTE 1	A / Tilt	NOTE 1
11	PCS1900+802.11a+Bluetooth	NOTE 1	A / Tilt	NOTE 1
12	WCDMA1900+802.11a+Bluetooth	NOTE 1	A / Tilt	NOTE 1
13	GSM850+802.11a+Bluetooth	NOTE 1	C : Body / Bottom	NOTE 1
14	WCDMA850+802.11a+Blueooth	NOTE 1	C : Body / Bottom	NOTE 1
15	PCS1900+802.11a+Bluetooth	NOTE 1	C : Body / Bottom	NOTE 1
16	WCDMA1900+802.11a+Bluetooth	NOTE 1	C : Body / Bottom	NOTE 1

NOTE: 1. The combination is from the worst situation of each communication mode.
 2. Assessment position A: Right head position, B: Left head position, C: Body position, please refer to appendix E for the photo.

4.3 SUMMARY OF TEST RESULTS

The worst situation has been chosen from the above table, and make up following combinations for the test of co-location listed as below.

TEST MODE	DESCRIPTION	MEASURED VALUE OF 1g SAR (W/kg)
1	GSM850+802.11g+Bluetooth	0.665
2	WCDMA850+802.11g+Blueooth	0.610
3	PCS1900+802.11g+Bluetooth	0.642
4	WCDMA1900+802.11g+Bluetooth	0.771
5	GSM850+802.11g+Bluetooth	0.141
6	WCDMA850+802.11g+Blueooth	0.045
7	PCS1900+802.11g+Bluetooth	0.040
8	WCDMA1900+802.11g+Bluetooth	0.044
9	GSM850+802.11a+Bluetooth	1.150
10	WCDMA850+802.11a+Blueooth	1.150
11	PCS1900+802.11a+Bluetooth	1.150
12	WCDMA1900+802.11a+Bluetooth	1.150
13	GSM850+802.11a+Bluetooth	0.141
14	WCDMA850+802.11a+Blueooth	0.113
15	PCS1900+802.11a+Bluetooth	0.113
16	WCDMA1900+802.11a+Bluetooth	0.113

5. TEST RESULTS

5.1 TEST PROCEDURES

For Mobile Phone:

The EUT (EDA (Enterprise Digital Assistant)) makes a phone call to the communication simulator station. Establish the simulation communication configuration rather the actual communication. Then the EUT could continuous the transmission mode. Adjust the PCL of the base station could controlled the EUT to transmitted the maximum output power. The base station also could control the transmission channel. The SAR value was calculated via the 3D spline interpolation algorithm that has been implemented in the software of DASY4 SAR measurement system manufactured and calibrated by SPEAG. According to the IEEE 1528 / EN 50361, the recommended procedure for assessing the peak spatial-average SAR value consists of the following steps:

For WLAN & Bluetooth:

The EUT (EDA (Enterprise Digital Assistant)) use the software to control the EUT channel and transmission power. Then record the conducted power before the testing. Place the EUT to the specific test location. After the testing, must writing down the conducted power of the EUT into the report. The SAR value was calculated via the 3D spline interpolation algorithm that has been implemented in the software of DASY4 SAR measurement system manufactured and calibrated by SPEAG. According to the IEEE P1528 / EN 50361 standards, the recommended procedure for assessing the peak spatial-average SAR value consists of the following steps:

- Power reference measurement
- Verification of the power reference measurement
- Area scan
- Zoom scan
- Power reference measurement

The area scan with 15mm x 15mm grid was performed for the highest spatial SAR location. Consist of 11 x 13 points while the scan size is the 150mm x 180mm. The zoom scan with 30mm x 30mm x 30mm volume was performed for SAR value averaged over 1g and 10g spatial volumes.



In the zoom scan, the distance between the measurement point at the probe sensor location (geometric center behind the probe tip) and the phantom surface is 4.0 mm and maintained at a constant distance of ± 1.0 mm during a zoom scan to determine peak SAR locations. The distance is 4mm between the first measurement point and the bottom surface of the phantom. The secondary measurement point to the bottom surface of the phantom is with 9mm separation distance. The cube size is 7 x 7 x 7 points consist of 343 points and the grid space is 5mm.

The measurement time is 0.5 s at each point of the zoom scan. The probe boundary effect compensation shall be applied during the SAR test. Because of the tip of the probe to the Phantom surface separated distances are longer than half a tip probe diameter.

In the area scan, the separation distance is 4mm between the each measurement point and the phantom surface. The scan size shall be included the transmission portion of the EUT. The measurement time is the same as the zoom scan. At last the reference power drift shall be less than $\pm 5\%$.

5.2 MEASURED SAR RESULTS

GSM850+WLAN(802.11g)+BLUETOOTH BAND LEFT / TILT HEAD POSITION

ENVIRONMENTAL CONDITION		Air Temperature : 22.5°C, Liquid Temperature : 21.3°C Humidity : 57%RH					
TESTED BY		Sam Onn			DATE	Feb. 01, 2008	
CHAN.	FREQ. (MHz)	MODULATION TYPE	CONDUCTED POWER		POWER DRIFT (%)	DEVICE TEST POSITION MODE	MEASURED 1g SAR (W/kg)
			BEGIN TEST	AFTER TEST			
128	824.2 (Low)	GMSK	1.905W	1.877W	-1.46	1	0.665
6	2437 (Mid.)	802.11g	101.86mW	100.34mW	-1.49		
0	2402 (Low)	Bluetooth	2.04mW	2.02mW	-0.98		

NOTE:

1. Test configuration of each mode is described in section 3.
2. In this testing, the limit for General Population Spatial Peak averaged over **1g, 1.6W/kg**, is applied.
3. Please see the Appendix A for the data.
4. The variation of the EUT conducted power measured before and after SAR testing should not over 5%.

WCDMA850+WLAN(802.11g)+BLUETOOTH BAND LEFT / TILT HEAD POSITION

ENVIRONMENTAL CONDITION		Air Temperature : 22.5°C, Liquid Temperature : 21.3°C Humidity : 57%RH					
TESTED BY		Sam Onn			DATE	Feb. 01, 2008	
CHAN.	FREQ. (MHz)	MODULATION TYPE	CONDUCTED POWER		POWER DRIFT (%)	DEVICE TEST POSITION MODE	MEASURED 1g SAR (W/kg)
			BEGIN TEST	AFTER TEST			
4233	846.6 (High)	BPSK	0.393W	0.387W	-1.53	2	0.610
6	2437 (Mid.)	802.11g	101.86mW	100.34mW	-1.49		
0	2402 (Low)	Bluetooth	2.04mW	2.02mW	-0.98		

NOTE:

1. Test configuration of each mode is described in section 3.
2. In this testing, the limit for General Population Spatial Peak averaged over **1g, 1.6W/kg**, is applied.
3. Please see the Appendix A for the data.
4. The variation of the EUT conducted power measured before and after SAR testing should not over 5%.



PCS1900+WLAN(802.11g)+BLUETOOTH BAND LEFT / TILT HEAD POSITION

ENVIRONMENTAL CONDITION		Air Temperature : 22.0°C, Liquid Temperature : 20.9°C Humidity : 55%RH					
TESTED BY		Sam Onn			DATE	Feb. 03, 2008	
CHAN.	FREQ. (MHz)	MODULATION TYPE	CONDUCTED POWER		POWER DRIFT (%)	DEVICE TEST POSITION MODE	MEASURED 1g SAR (W/kg)
			BEGIN TEST	AFTER TEST			
810	1909.8 (High)	GMSK	0.912W	0.898W	-1.52	3	0.642
6	2437 (Mid.)	802.11g	101.86mW	100.34mW	-1.49		
0	2402 (Low)	Bluetooth	2.04mW	2.02mW	-0.98		

NOTE:

1. Test configuration of each mode is described in section 3.
2. In this testing, the limit for General Population Spatial Peak averaged over **1g, 1.6W/kg**, is applied.
3. Please see the Appendix A for the data.
4. The variation of the EUT conducted power measured before and after SAR testing should not over 5%.



WCDMA1900+WLAN(802.11g)+BLUETOOTH BAND LEFT / TILT HEAD POSITION

ENVIRONMENTAL CONDITION		Air Temperature : 22.0°C, Liquid Temperature : 20.9°C Humidity : 55%RH					
TESTED BY		Sam Onn			DATE	Feb. 03, 2008	
CHAN.	FREQ. (MHz)	MODULATION TYPE	CONDUCTED POWER		POWER DRIFT (%)	DEVICE TEST POSITION MODE	MEASURED 1g SAR (W/kg)
			BEGIN TEST	AFTER TEST			
9400	1880.0 (Mid.)	BPSK	0.494W	0.488W	-1.21	4	0.771
6	2437 (Mid.)	802.11g	101.86mW	100.34mW	-1.49		
0	2402 (Low)	Bluetooth	2.04mW	2.02mW	-0.98		

NOTE:

1. Test configuration of each mode is described in section 3.
2. In this testing, the limit for General Population Spatial Peak averaged over **1g, 1.6W/kg**, is applied.
3. Please see the Appendix A for the data.
4. The variation of the EUT conducted power measured before and after SAR testing should not over 5%.

GSM850+WLAN(802.11g)+BLUETOOTH BAND BODY POSITION

ENVIRONMENTAL CONDITION		Air Temperature : 22.3°C, Liquid Temperature : 21.2°C Humidity : 55%RH					
TESTED BY		Sam Onn			DATE	Feb. 02, 2008	
CHAN.	FREQ. (MHz)	MODULATION TYPE	CONDUCTED POWER		POWER DRIFT (%)	DEVICE TEST POSITION MODE	MEASURED 1g SAR (W/kg)
			BEGIN TEST	AFTER TEST			
251	848.8 (High)	GMSK	1.995W	1.975W	-1.00	5	0.141
11	2462 (High)	802.11g	44.67mW	44.23mW	-0.99		
0	2402 (Low)	Bluetooth	2.04mW	2.01mW	-1.47		

NOTE:

1. Test configuration of each mode is described in section 3.
2. In this testing, the limit for General Population Spatial Peak averaged over **1g, 1.6W/kg**, is applied.
3. Please see the Appendix A for the data.
4. The variation of the EUT conducted power measured before and after SAR testing should not over 5%.

WCDMA850+WLAN(802.11g)+BLUETOOTH BAND BODY POSITION

ENVIRONMENTAL CONDITION		Air Temperature : 22.3°C, Liquid Temperature : 21.2°C Humidity : 55%RH					
TESTED BY		Sam Onn			DATE	Feb. 02, 2008	
CHAN.	FREQ. (MHz)	MODULATION TYPE	CONDUCTED POWER (W)		POWER DRIFT (%)	DEVICE TEST POSITION MODE	MEASURED 1g SAR (W/kg)
			BEGIN TEST	AFTER TEST			
4233	846.6 (High)	BPSK	0.393W	0.386W	-1.78	6	0.045
11	2462 (High)	802.11g	44.67mW	44.23mW	-0.99		
0	2402 (Low)	Bluetooth	2.04mW	2.01mW	-1.47		

NOTE:

1. Test configuration of each mode is described in section 3.
2. In this testing, the limit for General Population Spatial Peak averaged over **1g, 1.6W/kg**, is applied.
3. Please see the Appendix A for the data.
4. The variation of the EUT conducted power measured before and after SAR testing should not over 5%.

PCS1900+WLAN(802.11g)+BLUETOOTH BAND BODY POSITION

ENVIRONMENTAL CONDITION		Air Temperature : 22.1°C, Liquid Temperature : 21.3°C Humidity : 58%RH					
TESTED BY		Sam Onn			DATE	Feb. 04, 2008	
CHAN.	FREQ. (MHz)	MODULATION TYPE	CONDUCTED POWER		POWER DRIFT (%)	DEVICE TEST POSITION MODE	MEASURED 1g SAR (W/kg)
			BEGIN TEST	AFTER TEST			
661	1880.0 (Mid.)	GMSK	0.955W	0.949W	-0.63	7	0.040
11	2462 (High)	802.11g	44.67mW	44.23mW	-0.99		
0	2402 (Low)	Bluetooth	2.04mW	2.01mW	-1.47		

NOTE:

1. Test configuration of each mode is described in section 3.
2. In this testing, the limit for General Population Spatial Peak averaged over **1g, 1.6W/kg**, is applied.
3. Please see the Appendix A for the data.
4. The variation of the EUT conducted power measured before and after SAR testing should not over 5%.

WCDMA1900+WLAN(802.11g)+BLUETOOTH BAND BODY POSITION

ENVIRONMENTAL CONDITION		Air Temperature : 22.1°C, Liquid Temperature : 21.3°C Humidity : 58%RH					
TESTED BY		Sam Onn			DATE	Feb. 04, 2008	
CHAN.	FREQ. (MHz)	MODULATION TYPE	CONDUCTED POWER		POWER DRIFT (%)	DEVICE TEST POSITION MODE	MEASURED 1g SAR (W/kg)
			BEGIN TEST	AFTER TEST			
9400	1880.0 (Mid.)	BPSK	0.494W	0.491W	-0.61	8	0.044
11	2462 (High)	802.11g	44.67mW	44.23mW	-0.99		
0	2402 (Low)	Bluetooth	2.04mW	2.01mW	-1.47		

NOTE:

1. Test configuration of each mode is described in section 3.
2. In this testing, the limit for General Population Spatial Peak averaged over **1g, 1.6W/kg**, is applied.
3. Please see the Appendix A for the data.
4. The variation of the EUT conducted power measured before and after SAR testing should not over 5%.

GSM850+WLAN(802.11a)+BLUETOOTH BAND RIGHT / TILT HEAD POSITION

ENVIRONMENTAL CONDITION		Air Temperature : 22.5°C, Liquid Temperature : 21.4°C Humidity : 58%RH					
TESTED BY		Sam Onn			DATE	Feb. 07, 2008	
CHAN.	FREQ. (MHz)	MODULATION TYPE	CONDUCTED POWER		POWER DRIFT (%)	DEVICE TEST POSITION MODE	MEASURED 1g SAR (W/kg)
			BEGIN TEST	AFTER TEST			
128	824.2 (Low)	GMSK	1.905W	1.878W	-1.42	9	1.15
36	5180	802.11a	12.79mW	12.71mW	-0.63		
0	2402 (Low)	Bluetooth	2.04mW	2.03mW	-0.49		

NOTE:

1. Test configuration of each mode is described in section 3.
2. In this testing, the limit for General Population Spatial Peak averaged over **1g, 1.6W/kg**, is applied.
3. Please see the Appendix A for the data.
4. The variation of the EUT conducted power measured before and after SAR testing should not over 5%.

WCDMA850+WLAN(802.11 a)+BLUETOOTH BAND RIGHT / TILT HEAD POSITION

ENVIRONMENTAL CONDITION		Air Temperature : 22.5°C, Liquid Temperature : 21.4°C Humidity : 58%RH					
TESTED BY		Sam Onn			DATE	Feb. 07, 2008	
CHAN.	FREQ. (MHz)	MODULATION TYPE	CONDUCTED POWER		POWER DRIFT (%)	DEVICE TEST POSITION MODE	MEASURED 1g SAR (W/kg)
			BEGIN TEST	AFTER TEST			
4233	846.6 (High)	BPSK	0.393W	0.388W	-1.27	10	1.15
36	5180	802.11a	12.79mW	12.71mW	-0.63		
0	2402 (Low)	Bluetooth	2.04mW	2.03mW	-0.49		

NOTE:

1. Test configuration of each mode is described in section 3.
2. In this testing, the limit for General Population Spatial Peak averaged over **1g, 1.6W/kg**, is applied.
3. Please see the Appendix A for the data.
4. The variation of the EUT conducted power measured before and after SAR testing should not over 5%.

PCS1900+WLAN(802.11a)+BLUETOOTH BAND RIGHT / TILT HEAD POSITION

ENVIRONMENTAL CONDITION		Air Temperature : 22.5°C, Liquid Temperature : 21.4°C Humidity : 58%RH					
TESTED BY		Sam Onn			DATE	Feb. 07, 2008	
CHAN.	FREQ. (MHz)	MODULATION TYPE	CONDUCTED POWER		POWER DRIFT (%)	DEVICE TEST POSITION MODE	MEASURED 1g SAR (W/kg)
			BEGIN TEST	AFTER TEST			
810	1909.8 (High)	GMSK	0.912W	0.901W	-1.21	11	1.15
36	5180	802.11a	12.79mW	12.71mW	-0.63		
0	2402 (Low)	Bluetooth	2.04mW	2.03mW	-0.49		

NOTE:

1. Test configuration of each mode is described in section 3.
2. In this testing, the limit for General Population Spatial Peak averaged over **1g, 1.6W/kg**, is applied.
3. Please see the Appendix A for the data.
4. The variation of the EUT conducted power measured before and after SAR testing should not over 5%.



WCDMA1900+WLAN(802.11a)+BLUETOOTH BAND RIGHT / TILT HEAD POSITION

ENVIRONMENTAL CONDITION		Air Temperature : 22.5°C, Liquid Temperature : 21.4°C Humidity : 58%RH					
TESTED BY		Sam Onn			DATE	Feb. 07, 2008	
CHAN.	FREQ. (MHz)	MODULATION TYPE	CONDUCTED POWER		POWER DRIFT (%)	DEVICE TEST POSITION MODE	MEASURED 1g SAR (W/kg)
			BEGIN TEST	AFTER TEST			
9400	1880.0 (Mid.)	BPSK	0.494W	0.489W	-1.01	12	1.15
36	5180	802.11a	12.79mW	12.71mW	-0.63		
0	2402 (Low)	Bluetooth	2.04mW	2.03mW	-0.49		

NOTE:

1. Test configuration of each mode is described in section 3.
2. In this testing, the limit for General Population Spatial Peak averaged over **1g, 1.6W/kg**, is applied.
3. Please see the Appendix A for the data.
4. The variation of the EUT conducted power measured before and after SAR testing should not over 5%.

GSM850+WLAN(802.11a)+BLUETOOTH BAND BODY POSITION

ENVIRONMENTAL CONDITION		Air Temperature : 22.3°C, Liquid Temperature : 21.4°C Humidity : 56%RH					
TESTED BY		Sam Onn			DATE	Feb. 09, 2008	
CHAN.	FREQ. (MHz)	MODULATION TYPE	CONDUCTED POWER		POWER DRIFT (%)	DEVICE TEST POSITION MODE	MEASURED 1g SAR (W/kg)
			BEGIN TEST	AFTER TEST			
251	848.8 (High)	GMSK	1.995W	1.975W	-1.00	13	0.141
52	5260	802.11a	13.18mW	13.09mW	-0.68		
0	2402 (Low)	Bluetooth	2.04mW	2.01mW	-1.47		

NOTE:

1. Test configuration of each mode is described in section 3.
2. In this testing, the limit for General Population Spatial Peak averaged over **1g, 1.6W/kg**, is applied.
3. Please see the Appendix A for the data.
4. The variation of the EUT conducted power measured before and after SAR testing should not over 5%.

WCDMA850+WLAN(802.11a)+BLUETOOTH BAND BODY POSITION

ENVIRONMENTAL CONDITION		Air Temperature : 22.3°C, Liquid Temperature : 21.4°C Humidity : 56%RH					
TESTED BY		Sam Onn			DATE	Feb. 09, 2008	
CHAN.	FREQ. (MHz)	MODULATION TYPE	CONDUCTED POWER		POWER DRIFT (%)	DEVICE TEST POSITION MODE	MEASURED 1g SAR (W/kg)
			BEGIN TEST	AFTER TEST			
4233	846.6 (High)	BPSK	0.393W	0.386W	-1.78	14	0.113
52	5260	802.11a	13.18mW	13.09mW	-0.68		
0	2402 (Low)	Bluetooth	2.04mW	2.01mW	-1.47		

NOTE:

1. Test configuration of each mode is described in section 3.
2. In this testing, the limit for General Population Spatial Peak averaged over **1g, 1.6W/kg**, is applied.
3. Please see the Appendix A for the data.
4. The variation of the EUT conducted power measured before and after SAR testing should not over 5%.

PCS1900+WLAN(802.11a)+BLUETOOTH BAND BODY POSITION

ENVIRONMENTAL CONDITION		Air Temperature : 22.3°C, Liquid Temperature : 21.4°C Humidity : 56%RH					
TESTED BY		Sam Onn			DATE	Feb. 09, 2008	
CHAN.	FREQ. (MHz)	MODULATION TYPE	CONDUCTED POWER		POWER DRIFT (%)	DEVICE TEST POSITION MODE	MEASURED 1g SAR (W/kg)
			BEGIN TEST	AFTER TEST			
661	1880.0 (Mid.)	GMSK	0.955W	0.949W	-0.63	15	0.113
52	5260	802.11a	13.18mW	13.09mW	-0.68		
0	2402 (Low)	Bluetooth	2.04mW	2.01mW	-1.47		

NOTE:

1. Test configuration of each mode is described in section 3.
2. In this testing, the limit for General Population Spatial Peak averaged over **1g, 1.6W/kg**, is applied.
3. Please see the Appendix A for the data.
4. The variation of the EUT conducted power measured before and after SAR testing should not over 5%.

WCDMA1900+WLAN(802.11a)+BLUETOOTH BAND BODY POSITION

ENVIRONMENTAL CONDITION		Air Temperature : 22.3°C, Liquid Temperature : 21.4°C Humidity : 56%RH					
TESTED BY		Sam Onn			DATE	Feb. 09, 2008	
CHAN.	FREQ. (MHz)	MODULATION TYPE	CONDUCTED POWER		POWER DRIFT (%)	DEVICE TEST POSITION MODE	MEASURED 1g SAR (W/kg)
			BEGIN TEST	AFTER TEST			
9400	1880.0 (Mid.)	BPSK	0.494W	0.491W	-0.61	16	0.113
52	5260	802.11a	13.18mW	13.09mW	-0.68		
0	2402 (Low)	Bluetooth	2.04mW	2.01mW	-1.47		

NOTE:

1. Test configuration of each mode is described in section 3.
2. In this testing, the limit for General Population Spatial Peak averaged over **1g, 1.6W/kg**, is applied.
3. Please see the Appendix A for the data.
4. The variation of the EUT conducted power measured before and after SAR testing should not over 5%.



6. INFORMATION ON THE TESTING LABORATORIES

We, ADT Corp., were founded in 1988 to provide our best service in EMC, Radio, Telecom and Safety consultation. Our laboratories are accredited and approved by the following approval agencies according to ISO/IEC 17025.

USA	FCC, UL, A2LA
GERMANY	TUV Rheinland
JAPAN	VCCI
NORWAY	NEMKO
CANADA	INDUSTRY CANADA , CSA
R.O.C.	TAF, BSMI, NCC
NETHERLANDS	Telefication
SINGAPORE	GOST-ASIA (MOU)
RUSSIA	CERTIS (MOU)

Copies of accreditation certificates of our laboratories obtained from approval agencies can be downloaded from our web site:

www.adt.com.tw/index.5/phtml. If you have any comments, please feel free to contact us at the following:

Linko EMC/RF Lab:

Tel: 886-2-26052180

Fax: 886-2-26051924

Hsin Chu EMC/RF Lab:

Tel: 886-3-5935343

Fax: 886-3-5935342

Hwa Ya EMC/RF/Safety/Telecom Lab:

Tel: 886-3-3183232

Fax: 886-3-3185050

Web Site: www.adt.com.tw

The address and road map of all our labs can be found in our web site also.



APPENDIX A:

Test Laboratory: Advance Data Technology

M01- Co-located-Left Head-Tilt-GSM850 Ch128+11g Ch6+BT Ch0

DUT: EDA ; Type: MC7596 ; Test Frequency: 824.2 MHz Frequency: 2437 MHz Frequency: 2402 MHz

Communication System: PCS 850 Communication System: 802.11g Communication System: Bluetooth ; Frequency: 824.2 MHz Frequency: 2437 MHz Frequency: 2402 MHz; Duty Cycle: 1:8.3 Duty Cycle: 1:1 Medium: HSL835 Medium: HSL2450 Medium parameters used: $f = 824.2$ MHz; $\sigma = 0.91$ mho/m; $\epsilon_r = 42.7$; $\rho = 1000$ kg/m³ Medium parameters used: $f = 2437$ MHz; $\sigma = 1.81$ mho/m; $\epsilon_r = 40.4$; $\rho = 1000$ kg/m³ Medium parameters used: $f = 2402$ MHz; $\sigma = 1.78$ mho/m; $\epsilon_r = 40.5$; $\rho = 1000$ kg/m³ ; Liquid level: 150 mm

Phantom section: Left Section ; DUT test position : Tilt ; Modulation type: GMSK

Antenna type : External Antenna ; Air temp. : 22.5 degrees ; Liquid temp. : 21.3 degrees

DASY4 Configuration:

- Probe: ET3DV6 - SN1790 ; ConvF(6.65, 6.65, 6.65)ConvF(4.74, 4.74, 4.74) ; Calibrated: 2007/11/20
- Sensor-Surface: 4mm (Mechanical Surface Detection)
- Electronics: DAE3 Sn579; Calibrated: 2007/3/23
- Phantom: SAM 12; Type: SAM V4.0; Serial: TP 1202
- Measurement SW: DASY4, V4.7 Build 53; Postprocessing SW: SEMCAD, V1.8 Build 172

Tilt position - Low Channel 128/Area Scan (8x13x1): Measurement grid: dx=15mm, dy=15mm
Maximum value of SAR (measured) = 0.651 mW/g

Tilt position - Low Channel 128/Zoom Scan (7x7x7) (7x7x7)/Cube 0: Measurement grid:
dx=5mm, dy=5mm, dz=5mm
Reference Value = 26.1 V/m
Peak SAR (extrapolated) = 1.00 W/kg
SAR(1 g) = 0.665 mW/g; SAR(10 g) = 0.423 mW/g
Maximum value of SAR (measured) = 0.721 mW/g

Tilt position - Mid Channel 6/Zoom Scan (7x7x7) (7x7x7)/Cube 0: Measurement grid:
dx=5mm, dy=5mm, dz=5mm
Reference Value = 16.8 V/m
Peak SAR (extrapolated) = 1.22 W/kg
SAR(1 g) = 0.497 mW/g; SAR(10 g) = 0.225 mW/g
Maximum value of SAR (measured) = 0.544 mW/g

Tilt position - Low Channel 0/Zoom Scan (7x7x7) (7x7x7)/Cube 0: Measurement grid:
dx=5mm, dy=5mm, dz=5mm
Reference Value = 0.990 V/m
Peak SAR (extrapolated) = 0.002 W/kg
SAR(1 g) = 8.5e-005 mW/g; SAR(10 g) = 5.6e-006
Maximum value of SAR (measured) = 0.008 mW/g

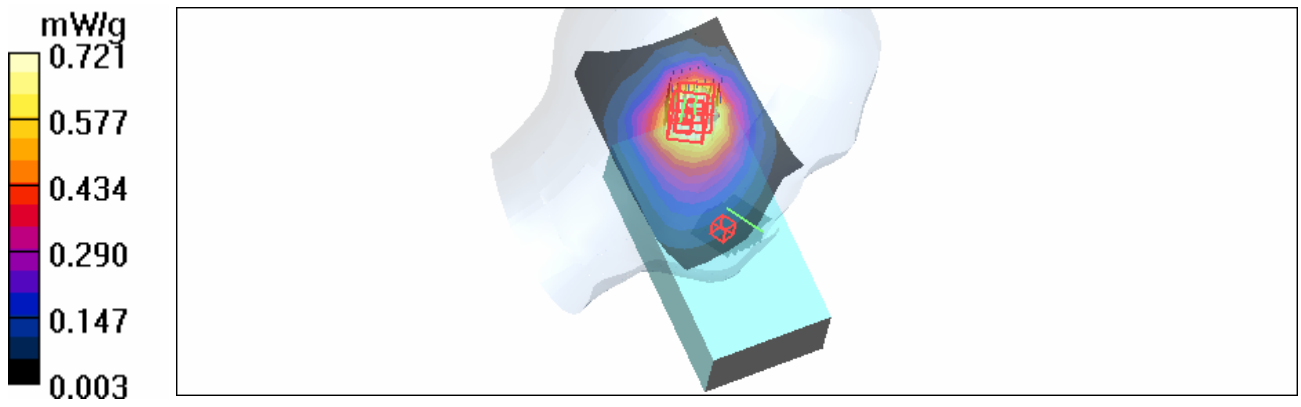

Test Laboratory: Advance Data Technology

M02- Co-located-Left Head-Tilt-WCDMA850 Ch4233+11g Ch6+BT Ch0

DUT: EDA ; Type: MC7596 ; Test Frequency: 846.6 MHz Frequency: 2437 MHz Frequency: 2402 MHz

Communication System: WCDMA Communication System: 802.11g Communication System: Bluetooth ; Frequency: 846.6 MHz Frequency: 2437 MHz Frequency: 2402 MHz; Duty Cycle: 1:1
Medium: HSL835 Medium: HSL2450 Medium parameters used : $f = 846.6 \text{ MHz}$; $\sigma = 0.93 \text{ mho/m}$; $\epsilon_r = 42.4$; $\rho = 1000 \text{ kg/m}^3$ Medium parameters used: $f = 2437 \text{ MHz}$; $\sigma = 1.81 \text{ mho/m}$; $\epsilon_r = 40.4$; $\rho = 1000 \text{ kg/m}^3$ Medium parameters used: $f = 2402 \text{ MHz}$; $\sigma = 1.78 \text{ mho/m}$; $\epsilon_r = 40.5$; $\rho = 1000 \text{ kg/m}^3$; Liquid level: 150 mm

Phantom section: Left Section ; DUT test position : Tilt ; Modulation type: BPSK

Antenna type : External Antenna ; Air temp. : 22.5 degrees ; Liquid temp. : 21.3 degrees

DASY4 Configuration:

- Probe: ET3DV6 - SN1790 ; ConvF(6.65, 6.65, 6.65)ConvF(4.74, 4.74, 4.74) ; Calibrated: 2007/11/20
- Sensor-Surface: 4mm (Mechanical Surface Detection)
- Electronics: DAE3 Sn579; Calibrated: 2007/3/23
- Phantom: SAM 12; Type: SAM V4.0; Serial: TP 1202
- Measurement SW: DASY4, V4.7 Build 53; Postprocessing SW: SEMCAD, V1.8 Build 172

Tilt position - High Channel 4233/Area Scan (8x13x1): Measurement grid: $dx=15\text{mm}$, $dy=15\text{mm}$

Maximum value of SAR (measured) = 0.613 mW/g

Tilt position - High Channel 4233/Zoom Scan (7x7x7) (7x7x7)/Cube 0: Measurement grid: $dx=5\text{mm}$, $dy=5\text{mm}$, $dz=5\text{mm}$

Reference Value = 22.8 V/m

Peak SAR (extrapolated) = 0.916 W/kg

SAR(1 g) = 0.610 mW/g; SAR(10 g) = 0.389 mW/g

Maximum value of SAR (measured) = 0.662 mW/g

Tilt position - Mid Channel 6/Zoom Scan (7x7x7) (7x7x7)/Cube 0: Measurement grid:

$dx=5\text{mm}$, $dy=5\text{mm}$, $dz=5\text{mm}$

Reference Value = 16.8 V/m

Peak SAR (extrapolated) = 1.22 W/kg

SAR(1 g) = 0.497 mW/g; SAR(10 g) = 0.225 mW/g

Maximum value of SAR (measured) = 0.544 mW/g

Tilt position - Low Channel 0/Zoom Scan (7x7x7) (7x7x7)/Cube 0: Measurement grid:

$dx=5\text{mm}$, $dy=5\text{mm}$, $dz=5\text{mm}$

Reference Value = 0.990 V/m

Peak SAR (extrapolated) = 0.002 W/kg

SAR(1 g) = 8.5e-005 mW/g; SAR(10 g) = 5.6e-006

Maximum value of SAR (measured) = 0.008 mW/g

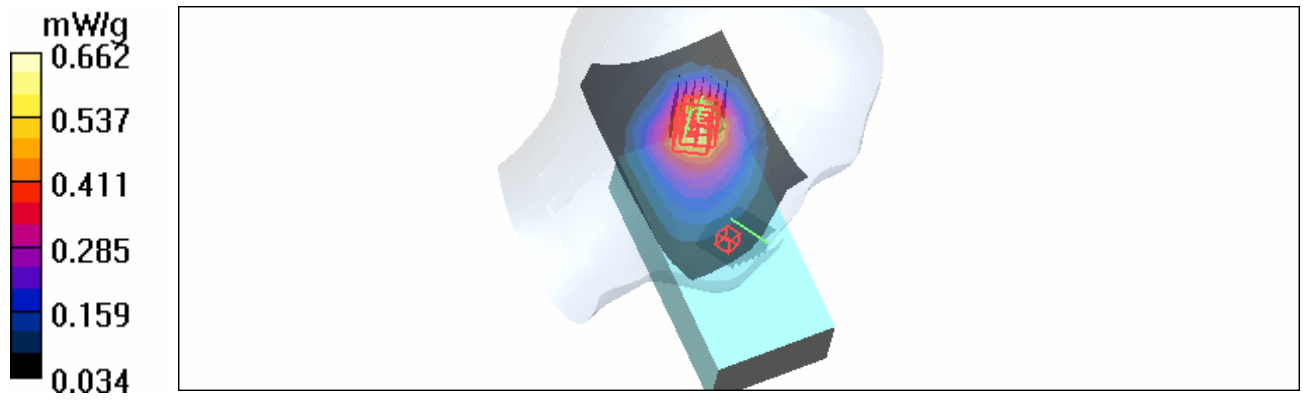

Test Laboratory: Advance Data Technology

M03- Co-located-Left Head-Tilt-PCS1900 Ch810+11g Ch6+BT Ch0

DUT: EDA ; Type: MC7596 ; Test Frequency: 1909.8 MHz Frequency: 2437 MHz Frequency: 2402 MHz

Communication System: PCS 1900 Communication System: 802.11g Communication System: Bluetooth ;
Frequency: 1909.8 MHz Frequency: 2437 MHz Frequency: 2402 MHz; Duty Cycle: 1:8.3 Duty Cycle: 1:1
Medium: HSL1900 Medium: HSL2450 Medium parameters used: $f = 1909.8 \text{ MHz}$; $\sigma = 1.45 \text{ mho/m}$; $\epsilon_r = 40.1$; $\rho = 1000 \text{ kg/m}^3$ Medium parameters used: $f = 2437 \text{ MHz}$; $\sigma = 1.81 \text{ mho/m}$; $\epsilon_r = 40.4$; $\rho = 1000 \text{ kg/m}^3$ Medium parameters used: $f = 2402 \text{ MHz}$; $\sigma = 1.78 \text{ mho/m}$; $\epsilon_r = 40.5$; $\rho = 1000 \text{ kg/m}^3$; Liquid level: 152 mm

Phantom section: Left Section ; DUT test position : Tilt ; Modulation type: GMSK

Antenna type : External Antenna ; Air temp. : 22.0 degrees ; Liquid temp. : 20.9 degrees

DASY4 Configuration:

- Probe: ET3DV6 - SN1790 ; ConvF(5.1, 5.1, 5.1) ConvF(4.74, 4.74, 4.74) ; Calibrated: 2007/11/20
- Sensor-Surface: 4mm (Mechanical Surface Detection)
- Electronics: DAE3 Sn579; Calibrated: 2007/3/23
- Phantom: SAM 12; Type: SAM V4.0; Serial: TP 1202
- Measurement SW: DASY4, V4.7 Build 53; Postprocessing SW: SEMCAD, V1.8 Build 172

Tilt position - High Channel 810/Area Scan (8x13x1): Measurement grid: $dx=15\text{mm}$, $dy=15\text{mm}$
Maximum value of SAR (measured) = 0.609 mW/g

Tilt position - High Channel 810/Zoom Scan (7x7x7) (7x7x7)/Cube 0: Measurement grid:
 $dx=5\text{mm}$, $dy=5\text{mm}$, $dz=5\text{mm}$
Reference Value = 14.3 V/m
Peak SAR (extrapolated) = 1.14 W/kg
SAR(1 g) = 0.642 mW/g; SAR(10 g) = 0.363 mW/g
Maximum value of SAR (measured) = 0.695 mW/g

Tilt position - Mid Channel 6/Zoom Scan (7x7x7) (7x7x7)/Cube 0: Measurement grid:
 $dx=5\text{mm}$, $dy=5\text{mm}$, $dz=5\text{mm}$
Reference Value = 16.8 V/m
Peak SAR (extrapolated) = 1.22 W/kg
SAR(1 g) = 0.497 mW/g; SAR(10 g) = 0.225 mW/g
Maximum value of SAR (measured) = 0.544 mW/g

Tilt position - Low Channel 0/Zoom Scan (7x7x7) (7x7x7)/Cube 0: Measurement grid:
 $dx=5\text{mm}$, $dy=5\text{mm}$, $dz=5\text{mm}$
Reference Value = 0.990 V/m
Peak SAR (extrapolated) = 0.002 W/kg
SAR(1 g) = 8.5e-005 mW/g; SAR(10 g) = 5.6e-006
Maximum value of SAR (measured) = 0.008 mW/g

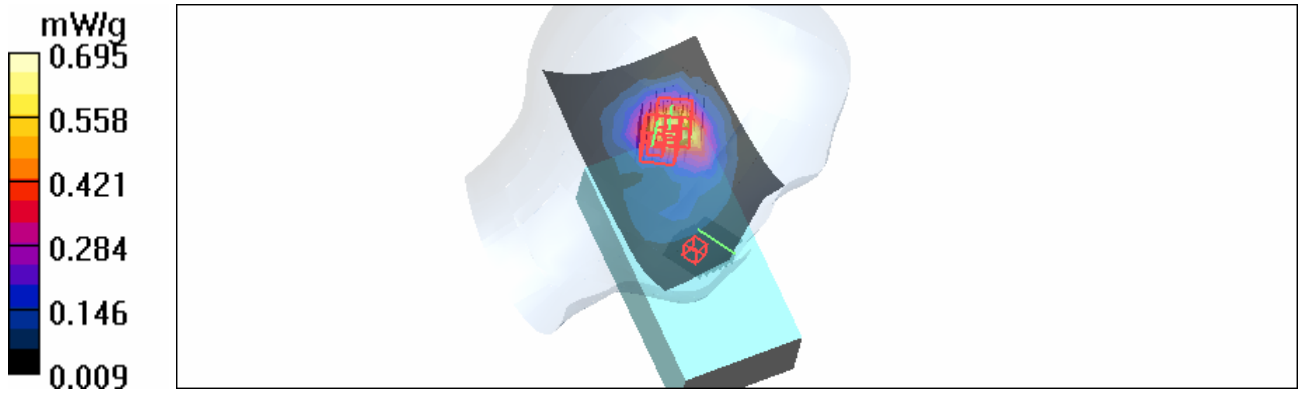

Test Laboratory: Advance Data Technology

M04- Co-located-Left Head-Tilt-WCDMA1900 Ch9400+11g Ch6+BT Ch0

DUT: EDA ; Type: MC7596 ; Test Frequency: 1880 MHz Frequency: 2437 MHz Frequency: 2402 MHz

Communication System: WCDMA1900 Communication System: 802.11g Communication System: Bluetooth ; Frequency: 1880 MHz Frequency: 2437 MHz Frequency: 2402 MHz; Duty Cycle: 1:1 Medium: HSL1900 Medium: HSL2450 Medium parameters used: $f = 1880$ MHz; $\sigma = 1.41$ mho/m; $\epsilon_r = 40.2$; $\rho = 1000$ kg/m³ Medium parameters used: $f = 2437$ MHz; $\sigma = 1.81$ mho/m; $\epsilon_r = 40.4$; $\rho = 1000$ kg/m³ Medium parameters used: $f = 2402$ MHz; $\sigma = 1.78$ mho/m; $\epsilon_r = 40.5$; $\rho = 1000$ kg/m³ ; Liquid level: 155 mm

Phantom section: Left Section ; DUT test position : Tilt ; Modulation type: BPSK

Antenna type : External Antenna ; Air temp. : 22.3 degrees ; Liquid temp. : 21.2 degrees

DASY4 Configuration:

- Probe: ET3DV6 - SN1790 ; ConvF(5.1, 5.1, 5.1)ConvF(4.74, 4.74, 4.74) ; Calibrated: 2007/11/20
- Sensor-Surface: 4mm (Mechanical Surface Detection)
- Electronics: DAE3 Sn579; Calibrated: 2007/3/23
- Phantom: SAM 12; Type: SAM V4.0; Serial: TP 1202
- Measurement SW: DASY4, V4.7 Build 53; Postprocessing SW: SEMCAD, V1.8 Build 172

Tilt position - Mid Channel 9400/Area Scan (8x13x1): Measurement grid: dx=15mm, dy=15mm

Maximum value of SAR (measured) = 0.825 mW/g

Tilt position - Mid Channel 9400/Zoom Scan (7x7x7) (7x7x7)/Cube 0: Measurement grid: dx=5mm, dy=5mm, dz=5mm

Reference Value = 16.4 V/m

Peak SAR (extrapolated) = 1.37 W/kg

SAR(1 g) = 0.771 mW/g; SAR(10 g) = 0.432 mW/g

Maximum value of SAR (measured) = 0.843 mW/g

Tilt position - Mid Channel 6/Zoom Scan (7x7x7) (7x7x7)/Cube 0: Measurement grid:

dx=5mm, dy=5mm, dz=5mm

Reference Value = 16.8 V/m

Peak SAR (extrapolated) = 1.22 W/kg

SAR(1 g) = 0.497 mW/g; SAR(10 g) = 0.225 mW/g

Maximum value of SAR (measured) = 0.544 mW/g

Tilt position - Low Channel 0/Zoom Scan (7x7x7) (7x7x7)/Cube 0: Measurement grid:

dx=5mm, dy=5mm, dz=5mm

Reference Value = 0.990 V/m

Peak SAR (extrapolated) = 0.002 W/kg

SAR(1 g) = 8.5e-005 mW/g; SAR(10 g) = 5.6e-006

Maximum value of SAR (measured) = 0.008 mW/g

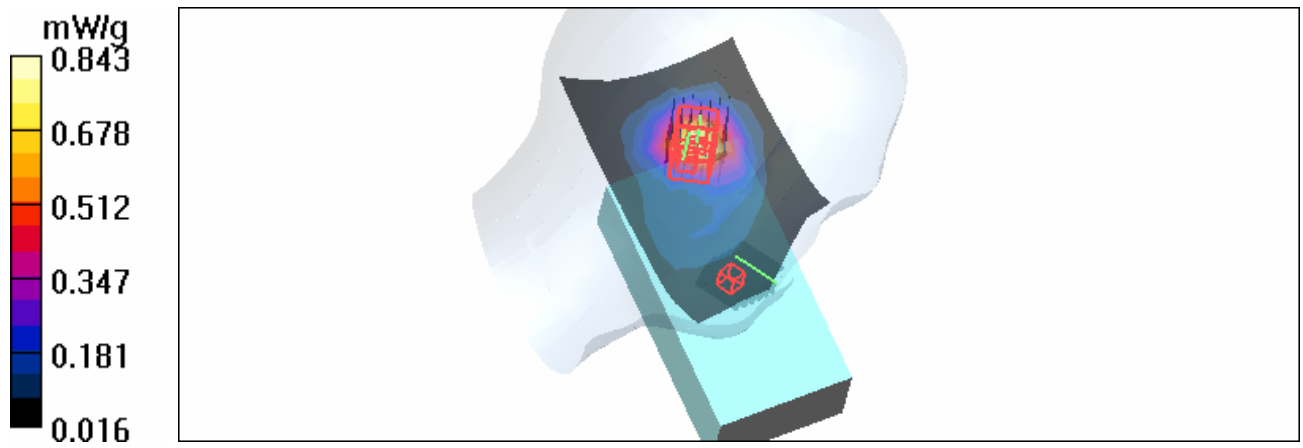

Test Laboratory: Advance Data Technology

M05- Co-located-Body Worn-GSM850-Ch251+11g Ch11+BT Ch0

DUT: EDA ; Type: MC7596 ; Test Frequency: 848.8 MHz Frequency: 2462 MHz Frequency: 2402 MHz

Communication System: PCS 850 Communication System: 802.11g Communication System: Bluetooth ;
Frequency: 848.8 MHz Frequency: 2462 MHz Frequency: 2402 MHz ; Duty Cycle: 1:4 Duty Cycle: 1:1
Medium: MSL835 Medium: MSL2450 Medium parameters used: $f = 848.8 \text{ MHz}$; $\sigma = 1.01 \text{ mho/m}$; $\epsilon_r = 56.3$; $\rho = 1000 \text{ kg/m}^3$ Medium parameters used: $f = 2462 \text{ MHz}$; $\sigma = 1.98 \text{ mho/m}$; $\epsilon_r = 53.6$; $\rho = 1000 \text{ kg/m}^3$ Medium parameters used: $f = 2402 \text{ MHz}$; $\sigma = 1.92 \text{ mho/m}$; $\epsilon_r = 53.9$; $\rho = 1000 \text{ kg/m}^3$; Liquid Level : 151 mm

Phantom section: Flat Section ; DUT test position : Body ; Modulation Type: GMSK

Separation Distance : 0 mm (The front side of the EUT to the Phantom)

Antenna Type : External Antenna ; Air Temp. : 22.3 degrees ; Liquid Temp. : 21.2 degrees

DASY4 Configuration:

- Probe: ET3DV6 - SN1790 ; ConvF(6.15, 6.15, 6.15)ConvF(4.16, 4.16, 4.16) ; Calibrated: 2007/11/20
- Sensor-Surface: 4mm (Mechanical Surface Detection)
- Electronics: DAE3 Sn579 ; Calibrated: 2007/3/23
- Phantom: SAM 12 ; Type: SAM V4.0; Serial: TP 1202
- Measurement SW: DASY4, V4.7 Build 53 ; Postprocessing SW: SEMCAD, V1.8 Build 172

High Channel 251/Area Scan (7x13x1): Measurement grid: $dx=15\text{mm}$, $dy=15\text{mm}$

Maximum value of SAR (measured) = 0.126 mW/g

High Channel 251/Zoom Scan (7x7x7) (7x7x7)/Cube 0: Measurement grid: $dx=5\text{mm}$, $dy=5\text{mm}$, $dz=5\text{mm}$

Reference Value = 11.9 V/m

Peak SAR (extrapolated) = 0.360 W/kg

SAR(1 g) = 0.141 mW/g; SAR(10 g) = 0.091 mW/g

Maximum value of SAR (measured) = 0.124 mW/g

High Channel 11/Zoom Scan (7x7x7) (7x7x7)/Cube 0: Measurement grid: $dx=5\text{mm}$, $dy=5\text{mm}$, $dz=5\text{mm}$

Reference Value = 0.913 V/m

Peak SAR (extrapolated) = 0.028 W/kg

SAR(1 g) = 0.00627 mW/g; SAR(10 g) = 0.00284 mW/g

Maximum value of SAR (measured) = 0.007 mW/g

Low Channel 0/Zoom Scan (7x7x7) (7x7x7)/Cube 0: Measurement grid: $dx=5\text{mm}$, $dy=5\text{mm}$, $dz=5\text{mm}$

Reference Value = 0.653 V/m

Peak SAR (extrapolated) = 0.001 W/kg

SAR(1 g) = 9.17e-006 mW/g; SAR(10 g) = 1.34e-006 mW/g

Maximum value of SAR (measured) = 0.002 mW/g

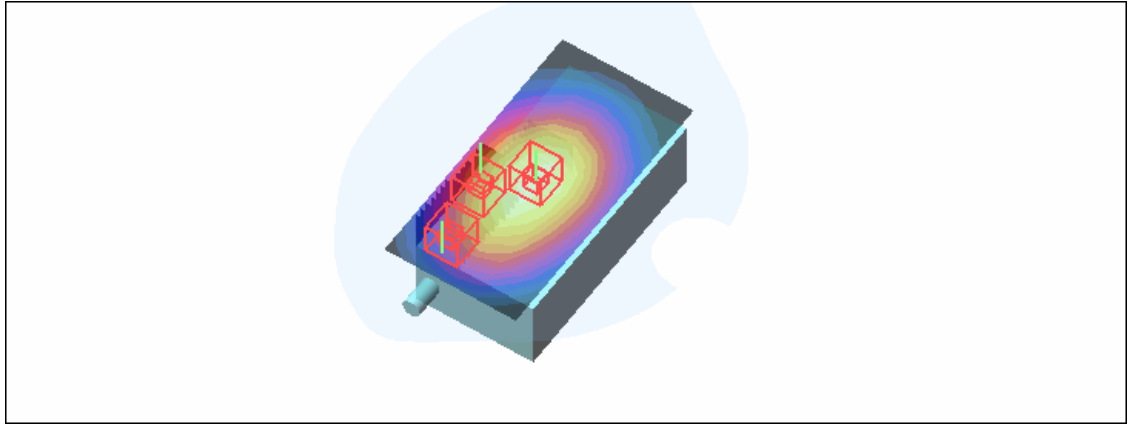
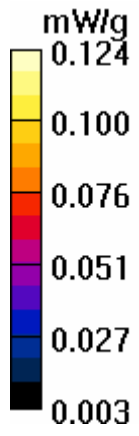

Test Laboratory: Advance Data Technology

M06- Co-located-Body Worn-WCDMA850 Ch4233+11g Ch11+BT Ch0

DUT: EDA ; Type: MC7596 ; Test Frequency: 846.6 MHz Frequency: 2462 MHz Frequency: 2402 MHz

Communication System: WCDMA Communication System: 802.11g Communication System: Bluetooth ;
Frequency: 846.6 MHz Frequency: 2462 MHz Frequency: 2402 MHz ; Duty Cycle: 1:1
Medium: MSL835 Medium: MSL2450 Medium parameters used: $f = 846.6 \text{ MHz}$; $\sigma = 1.01 \text{ mho/m}$; $\epsilon_r = 56.3$; $\rho = 1000 \text{ kg/m}^3$ Medium parameters used: $f = 2462 \text{ MHz}$; $\sigma = 1.98 \text{ mho/m}$; $\epsilon_r = 53.6$; $\rho = 1000 \text{ kg/m}^3$ Medium parameters used: $f = 2402 \text{ MHz}$; $\sigma = 1.92 \text{ mho/m}$; $\epsilon_r = 53.9$; $\rho = 1000 \text{ kg/m}^3$; Liquid Level : 153 mm
Phantom section: Flat Section ; DUT test position : Body ; Modulation Type: BPSK
Separation Distance : 0 mm (The front side of the EUT to the Phantom)
Antenna Type : External Antenna ; Air Temp. : 22.3 degrees ; Liquid Temp. : 21.2 degrees

DASY4 Configuration:

- Probe: ET3DV6 - SN1790 ; ConvF(6.15, 6.15, 6.15)ConvF(4.16, 4.16, 4.16) ; Calibrated: 2007/11/20
- Sensor-Surface: 4mm (Mechanical Surface Detection)
- Electronics: DAE3 Sn579 ; Calibrated: 2007/3/23
- Phantom: SAM 12 ; Type: SAM V4.0; Serial: TP 1202
- Measurement SW: DASY4, V4.7 Build 53 ; Postprocessing SW: SEMCAD, V1.8 Build 172

High Channel 4233/Area Scan (7x13x1): Measurement grid: $dx=15\text{mm}$, $dy=15\text{mm}$
Maximum value of SAR (measured) = 0.048 mW/g

High Channel 4233/Zoom Scan (7x7x7) (7x7x7)/Cube 0: Measurement grid: $dx=5\text{mm}$, $dy=5\text{mm}$, $dz=5\text{mm}$
Reference Value = 7.14 V/m
Peak SAR (extrapolated) = 0.055 W/kg
SAR(1 g) = 0.045 mW/g; SAR(10 g) = 0.034 mW/g

High Channel 11/Zoom Scan (7x7x7) (7x7x7)/Cube 0: Measurement grid: $dx=5\text{mm}$, $dy=5\text{mm}$, $dz=5\text{mm}$
Reference Value = 0.913 V/m
Peak SAR (extrapolated) = 0.028 W/kg
SAR(1 g) = 0.00627 mW/g; SAR(10 g) = 0.00284 mW/g
Maximum value of SAR (measured) = 0.007 mW/g

Low Channel 0/Zoom Scan (7x7x7) (7x7x7)/Cube 0: Measurement grid: $dx=5\text{mm}$, $dy=5\text{mm}$, $dz=5\text{mm}$
Reference Value = 0.653 V/m
Peak SAR (extrapolated) = 0.001 W/kg
SAR(1 g) = 9.17e-006 mW/g; SAR(10 g) = 1.34e-006 mW/g
Maximum value of SAR (measured) = 0.002 mW/g

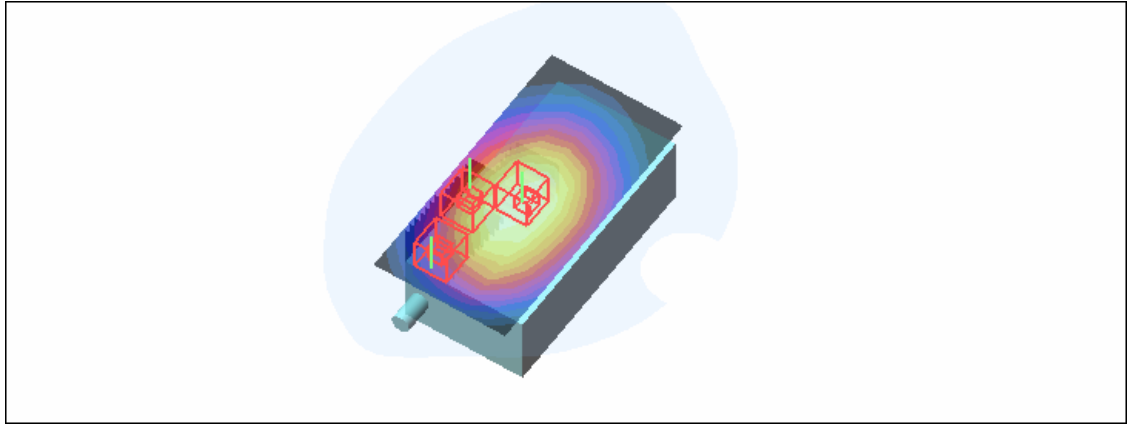
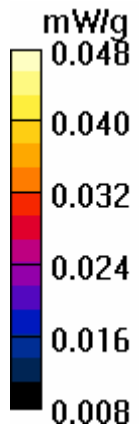

Test Laboratory: Advance Data Technology

M07- Co-located-Body Worn-GSM1900 Ch661+11g Ch11+BT Ch0

DUT: EDA ; Type: MC7596 ; Test Frequency: 1880 MHz Frequency: 2462 MHz Frequency: 2402 MHz

Communication System: PCS 1900 Communication System: 802.11g Communication System: Bluetooth ;
Frequency: 1880 MHz Frequency: 2462 MHz Frequency: 2402 MHz ; Duty Cycle: 1:8.3 Duty Cycle: 1:1
Medium: MSL1900 Medium: MSL2450 Medium parameters used: $f = 1880 \text{ MHz}$; $\sigma = 1.52 \text{ mho/m}$; $\epsilon_r = 54.7$; $\rho = 1000 \text{ kg/m}^3$ Medium parameters used: $f = 2462 \text{ MHz}$; $\sigma = 1.98 \text{ mho/m}$; $\epsilon_r = 53.6$; $\rho = 1000 \text{ kg/m}^3$ Medium parameters used: $f = 2402 \text{ MHz}$; $\sigma = 1.92 \text{ mho/m}$; $\epsilon_r = 53.9$; $\rho = 1000 \text{ kg/m}^3$; Liquid Level : 150 mm

Phantom section: Flat Section ; DUT test position : Body ; Modulation Type: GMSK

Separation Distance : 0 mm (The front side of the EUT to the Phantom)

Antenna Type : External Antenna ; Air Temp. : 22.1 degrees ; Liquid Temp. : 21.3 degrees

DASY4 Configuration:

- Probe: ET3DV6 - SN1790 ; ConvF(4.58, 4.58, 4.58)ConvF(4.16, 4.16, 4.16) ; Calibrated: 2007/11/20
- Sensor-Surface: 4mm (Mechanical Surface Detection)
- Electronics: DAE3 Sn579 ; Calibrated: 2007/3/23
- Phantom: SAM 12 ; Type: SAM V4.0; Serial: TP 1202
- Measurement SW: DASY4, V4.7 Build 53 ; Postprocessing SW: SEMCAD, V1.8 Build 172

Mid Channel 661/Area Scan (7x14x1): Measurement grid: $dx=15\text{mm}$, $dy=15\text{mm}$

Maximum value of SAR (measured) = 0.041 mW/g

Mid Channel 661/Zoom Scan (7x7x7) (7x7x7)/Cube 0: Measurement grid: $dx=5\text{mm}$, $dy=5\text{mm}$, $dz=5\text{mm}$

Reference Value = 4.04 V/m

Peak SAR (extrapolated) = 0.064 W/kg

SAR(1 g) = 0.040 mW/g; SAR(10 g) = 0.026 mW/g

Maximum value of SAR (measured) = 0.042 mW/g

Mid Channel 661/Zoom Scan (7x7x7) (7x7x7)/Cube 1: Measurement grid: $dx=5\text{mm}$, $dy=5\text{mm}$, $dz=5\text{mm}$

Reference Value = 4.67 V/m

Peak SAR (extrapolated) = 0.055 W/kg

SAR(1 g) = 0.034 mW/g; SAR(10 g) = 0.022 mW/g

Maximum value of SAR (measured) = 0.037 mW/g

High Channel 11/Zoom Scan (7x7x7) (7x7x7)/Cube 0: Measurement grid: $dx=5\text{mm}$, $dy=5\text{mm}$, $dz=5\text{mm}$

Reference Value = 0.913 V/m

Peak SAR (extrapolated) = 0.028 W/kg

SAR(1 g) = 0.00627 mW/g; SAR(10 g) = 0.00284 mW/g

Maximum value of SAR (measured) = 0.007 mW/g

Low Channel 0/Zoom Scan (7x7x7) (7x7x7)/Cube 0: Measurement grid: dx=5mm, dy=5mm, dz=5mm

Reference Value = 0.653 V/m

Peak SAR (extrapolated) = 0.001 W/kg

SAR(1 g) = 9.17e-006 mW/g; SAR(10 g) = 1.34e-006 mW/g

Maximum value of SAR (measured) = 0.002 mW/g

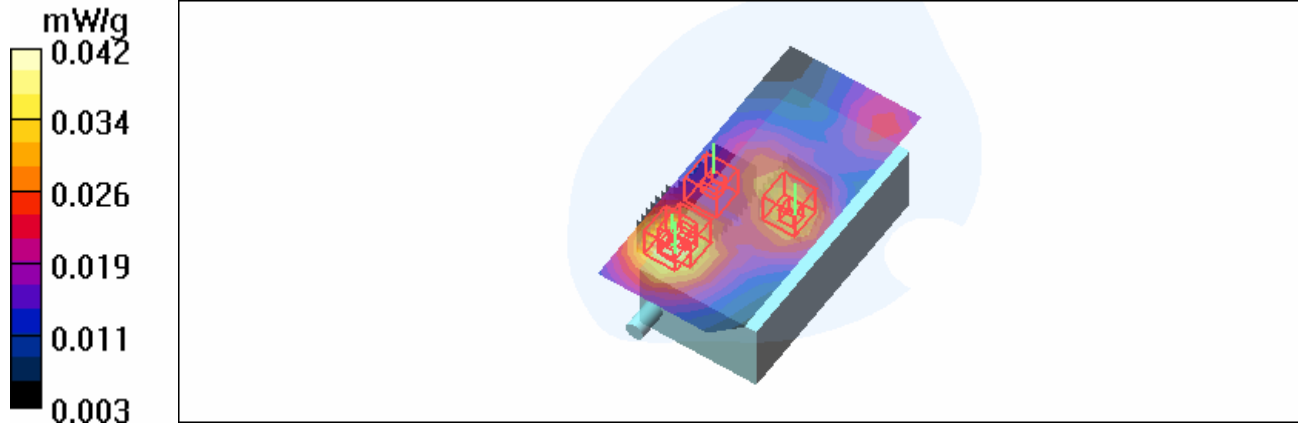

Test Laboratory: Advance Data Technology

M08- Co-located-Body Worn-WCDMA1900 Ch9400+11g Ch11+BT Ch0

DUT: EDA ; Type: MC7596 ; Test Frequency: 1880 MHz Frequency: 2462 MHz Frequency: 2402 MHz

Communication System: WCDMA1900 Communication System: 802.11g Communication System: Bluetooth ; Frequency: 1880 MHz Frequency: 2462 MHz Frequency: 2402 MHz ; Duty Cycle: 1:1 Medium: MSL1900 Medium: MSL2450 Medium parameters used: $f = 1880$ MHz; $\sigma = 1.52$ mho/m; $\epsilon_r = 54.7$; $\rho = 1000$ kg/m³ Medium parameters used: $f = 2462$ MHz; $\sigma = 1.98$ mho/m; $\epsilon_r = 53.6$; $\rho = 1000$ kg/m³ Medium parameters used: $f = 2402$ MHz; $\sigma = 1.92$ mho/m; $\epsilon_r = 53.9$; $\rho = 1000$ kg/m³ ; Liquid Level : 153 mm

Phantom section: Flat Section ; DUT test position : Body ; Modulation Type: BPSK

Separation Distance : 0 mm (The front side of the EUT to the Phantom)

Antenna Type : External Antenna ; Air Temp. : 23.0 degrees ; Liquid Temp. : 21.9 degrees

DASY4 Configuration:

- Probe: ET3DV6 - SN1790 ; ConvF(4.58, 4.58, 4.58)ConvF(4.16, 4.16, 4.16) ; Calibrated: 2007/11/20
- Sensor-Surface: 4mm (Mechanical Surface Detection)
- Electronics: DAE3 Sn579 ; Calibrated: 2007/3/23
- Phantom: SAM 12 ; Type: SAM V4.0; Serial: TP 1202
- Measurement SW: DASY4, V4.7 Build 53 ; Postprocessing SW: SEMCAD, V1.8 Build 172

Mid Channel 9400/Area Scan (7x13x1): Measurement grid: dx=15mm, dy=15mm

Maximum value of SAR (measured) = 0.043 mW/g

Mid Channel 9400/Zoom Scan (7x7x7) (7x7x7)/Cube 0: Measurement grid: dx=5mm, dy=5mm, dz=5mm

Reference Value = 3.96 V/m

Peak SAR (extrapolated) = 0.065 W/kg

SAR(1 g) = 0.044 mW/g; SAR(10 g) = 0.028 mW/g

Maximum value of SAR (measured) = 0.045 mW/g

Mid Channel 9400/Zoom Scan (7x7x7) (7x7x7)/Cube 1: Measurement grid: dx=5mm, dy=5mm, dz=5mm

Reference Value = 3.96 V/m

Peak SAR (extrapolated) = 0.047 W/kg

SAR(1 g) = 0.029 mW/g; SAR(10 g) = 0.019 mW/g

Maximum value of SAR (measured) = 0.031 mW/g

High Channel 11/Zoom Scan (7x7x7) (7x7x7)/Cube 0: Measurement grid: dx=5mm, dy=5mm, dz=5mm

Reference Value = 0.913 V/m

Peak SAR (extrapolated) = 0.028 W/kg

SAR(1 g) = 0.00627 mW/g; SAR(10 g) = 0.00284 mW/g

Maximum value of SAR (measured) = 0.007 mW/g

Low Channel 0/Zoom Scan (7x7x7) (7x7x7)/Cube 0: Measurement grid: dx=5mm, dy=5mm, dz=5mm

Reference Value = 0.653 V/m

Peak SAR (extrapolated) = 0.001 W/kg

SAR(1 g) = 9.17e-006 mW/g; SAR(10 g) = 1.34e-006 mW/g

Maximum value of SAR (measured) = 0.002 mW/g

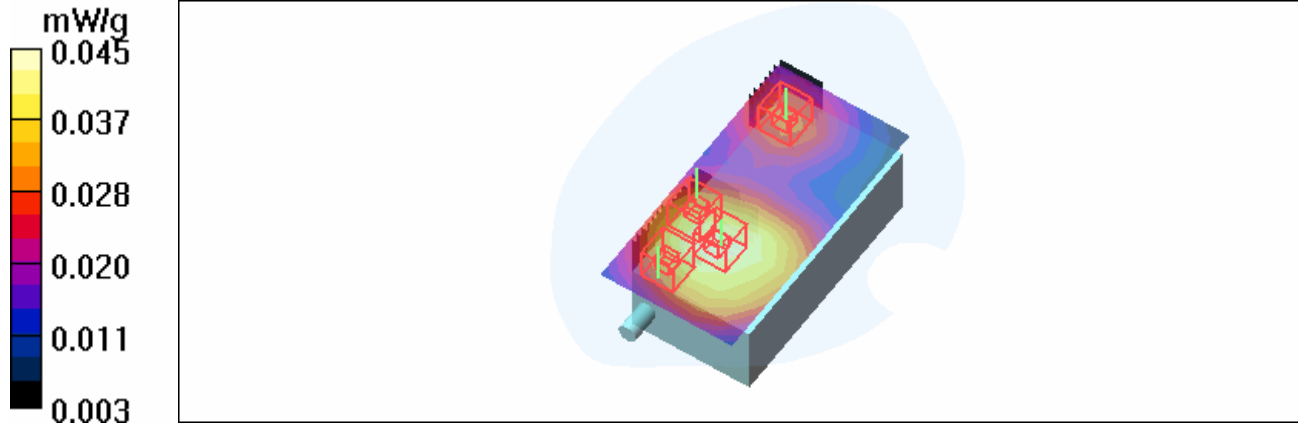

Test Laboratory: Advance Data Technology

M09- Co-located-Right Head-Tilt-11a Ch36+GSM850 Ch128+BT Ch0

DUT: EDA ; Type: MC7596 ; Test Frequency: 5180 MHz Frequency: 824.2 MHz Frequency: 2402 MHz

Communication System: 802.11a Communication System: PCS 850 Communication System: Bluetooth ; Frequency: 5180 MHz Frequency: 824.2 MHz Frequency: 2402 MHz; Duty Cycle: 1:1 Duty Cycle: 1:8.3 Medium: HSL5800 Medium: HSL835 Medium: HSL2450 Medium parameters used: $f = 5180$ MHz; $\sigma = 4.64$ mho/m; $\epsilon_r = 37.1$; $\rho = 1000$ kg/m³ Medium parameters used: $f = 824.2$ MHz; $\sigma = 0.91$ mho/m; $\epsilon_r = 42.7$; $\rho = 1000$ kg/m³ Medium parameters used: $f = 2402$ MHz; $\sigma = 1.78$ mho/m; $\epsilon_r = 40.5$; $\rho = 1000$ kg/m³ ; Liquid level: 154 mm

Phantom section: Right Section ; DUT test position : Tilt ; Modulation type: BPSK

Antenna type : PIFA Antenna ; Air temp. : 22.5 degrees ; Liquid temp. : 21.4 degrees

DASY4 Configuration:

- Probe: EX3DV3 - SN3506 Probe: ET3DV6 - SN1790 ; ConvF(4.92, 4.92, 4.92)ConvF(6.65, 6.65, 6.65)ConvF(4.74, 4.74, 4.74) ; Calibrated: 2007/3/20 Calibrated: 2007/11/20

- Sensor-Surface: 3mm (Mechanical Surface Detection) Sensor-Surface: 4mm (Mechanical Surface Detection)

- Electronics: DAE3 Sn579; Calibrated: 2007/3/23

- Phantom: SAM 12; Type: SAM V4.0; Serial: TP 1202

- Measurement SW: DASY4, V4.7 Build 53; Postprocessing SW: SEMCAD, V1.8 Build 172

Tilt Position - Low Channel 36/Area Scan (9x19x1): Measurement grid: dx=10mm, dy=10mm
Maximum value of SAR (measured) = 1.28 mW/g

Tilt Position - Low Channel 36/Zoom Scan (8x8x8)/Cube 0: Measurement grid: dx=4.3mm, dy=4.3mm, dz=3mm

Reference Value = 9.92 V/m

Peak SAR (extrapolated) = 3.93 W/kg

SAR(1 g) = 1.15 mW/g; SAR(10 g) = 0.386 mW/g

Maximum value of SAR (measured) = 1.36 mW/g

Tilt position - Low Channel 128/Zoom Scan (7x7x7) (7x7x7)/Cube 0: Measurement grid: dx=5mm, dy=5mm, dz=5mm

Reference Value = 24.2 V/m

Peak SAR (extrapolated) = 0.815 W/kg

SAR(1 g) = 0.576 mW/g; SAR(10 g) = 0.381 mW/g

Maximum value of SAR (measured) = 0.624 mW/g

Tilt position - Low Channel 0/Zoom Scan (7x7x7) (7x7x7)/Cube 0: Measurement grid:

dx=5mm, dy=5mm, dz=5mm

Reference Value = 0.440 V/m

Peak SAR (extrapolated) = 0.004 W/kg

SAR(1 g) = **0.000773** mW/g; SAR(10 g) = 0.000272 mW/g

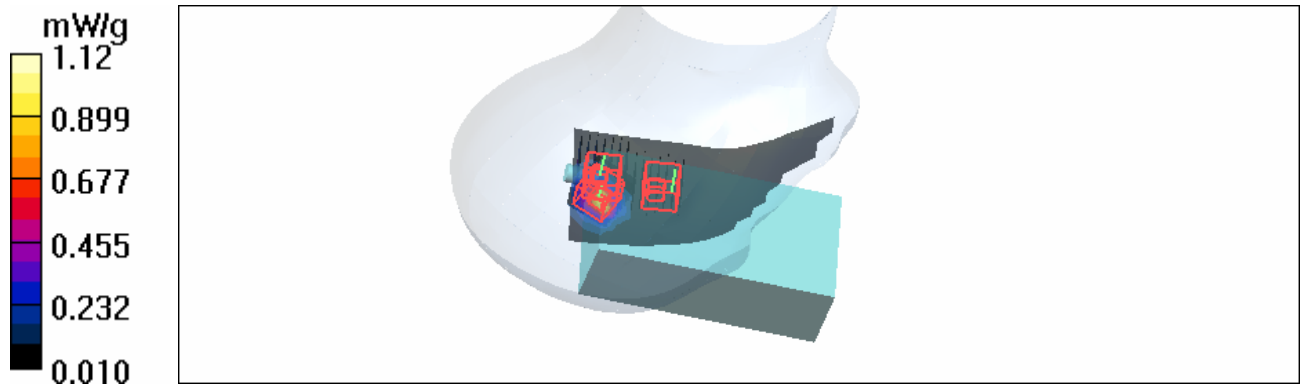

Test Laboratory: Advance Data Technology

M10- Co-located-Right Head-Tilt-11a-Ch36+WCDMA Ch4233+BT Ch0

DUT: EDA ; Type: MC7596 ; Test Frequency: 5180 MHz Frequency: 846.6 MHz Frequency: 2402 MHz

Communication System: 802.11a Communication System: WCDMA Communication System: Bluetooth ;
Frequency: 5180 MHz Frequency: 846.6 MHz Frequency: 2402 MHz; Duty Cycle: 1:1
Medium: HSL5800 Medium: HSL835 Medium: HSL2450 Medium parameters used: $f = 5180$ MHz; $\sigma = 4.64$ mho/m; $\epsilon_r = 37.1$; $\rho = 1000$ kg/m³ Medium parameters used : $f = 846.6$ MHz; $\sigma = 0.93$ mho/m; $\epsilon_r = 42.4$; $\rho = 1000$ kg/m³ Medium parameters used: $f = 2402$ MHz; $\sigma = 1.78$ mho/m; $\epsilon_r = 40.5$; $\rho = 1000$ kg/m³ ; Liquid level: 155 mm
Phantom section: Right Section ; DUT test position : Tilt ; Modulation type: BPSK
Antenna type : PIFA Antenna ; Air temp. : 22.3 degrees ; Liquid temp. : 21.2 degrees

DASY4 Configuration:

- Probe: EX3DV3 - SN3506 Probe: ET3DV6 - SN1790 ; ConvF(4.92, 4.92, 4.92) ConvF(6.65, 6.65, 6.65) ConvF(4.74, 4.74, 4.74) ; Calibrated: 2007/3/20 Calibrated: 2007/11/20
- Sensor-Surface: 3mm (Mechanical Surface Detection) Sensor-Surface: 4mm (Mechanical Surface Detection)
- Electronics: DAE3 Sn579; Calibrated: 2007/3/23
- Phantom: SAM 12; Type: SAM V4.0; Serial: TP 1202
- Measurement SW: DASY4, V4.7 Build 53; Postprocessing SW: SEMCAD, V1.8 Build 172

Tilt Position - Low Channel 36/Area Scan (9x19x1): Measurement grid: dx=10mm, dy=10mm
Maximum value of SAR (measured) = 1.28 mW/g

Tilt Position - Low Channel 36/Zoom Scan (8x8x8)/Cube 0: Measurement grid: dx=4.3mm, dy=4.3mm, dz=3mm
Reference Value = 9.92 V/m
Peak SAR (extrapolated) = 3.93 W/kg
SAR(1 g) = 1.15 mW/g; SAR(10 g) = 0.386 mW/g
Maximum value of SAR (measured) = 1.36 mW/g

Tilt position - High Channel 4233/Zoom Scan (7x7x7) (7x7x7)/Cube 0: Measurement grid: dx=5mm, dy=5mm, dz=5mm
Reference Value = 21.8 V/m
Peak SAR (extrapolated) = 0.783 W/kg
SAR(1 g) = 0.521 mW/g; SAR(10 g) = 0.338 mW/g
Maximum value of SAR (measured) = 0.595 mW/g

Tilt position - Low Channel 0/Zoom Scan (7x7x7) (7x7x7)/Cube 0: Measurement grid: dx=5mm, dy=5mm, dz=5mm
Reference Value = 0.440 V/m
Peak SAR (extrapolated) = 0.004 W/kg

SAR(1 g) = 0.000773 mW/g; SAR(10 g) = 0.000272 mW/g

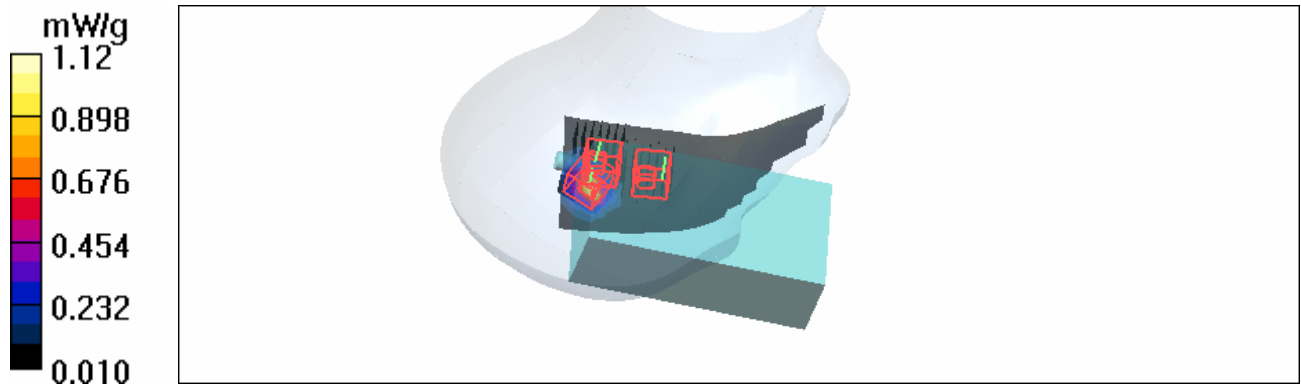

Test Laboratory: Advance Data Technology

M11- Co-located-Right Head-Tilt-11a Ch36+PCS1900 Ch810+BT Ch0

DUT: EDA ; Type: MC7596 ; Test Frequency: 5180 MHz Frequency: 1909.8 MHz Frequency: 2402 MHz

Communication System: 802.11a Communication System: PCS 1900 Communication System: Bluetooth ; Frequency: 5180 MHz Frequency: 1909.8 MHz Frequency: 2402 MHz; Duty Cycle: 1:1 Duty Cycle: 1:8.3

Medium: HSL5800 Medium: HSL1900 Medium: HSL2450 Medium parameters used: $f = 5180$ MHz; $\sigma = 4.64$ mho/m; $\epsilon_r = 37.1$; $\rho = 1000$ kg/m³ Medium parameters used: $f = 1909.8$ MHz; $\sigma = 1.45$ mho/m; $\epsilon_r = 40.1$; $\rho = 1000$ kg/m³ Medium parameters used: $f = 2402$ MHz; $\sigma = 1.78$ mho/m; $\epsilon_r = 40.5$; $\rho = 1000$ kg/m³ ; Liquid level: 154 mm

Phantom section: Right Section ; DUT test position : Tilt ; Modulation type: BPSK

Antenna type : PIFA Antenna ; Air temp. : 22.5 degrees ; Liquid temp. : 21.4 degrees

DASY4 Configuration:

- Probe: EX3DV3 - SN3506 Probe: ET3DV6 - SN1790 ; ConvF(4.92, 4.92, 4.92) ConvF(5.1, 5.1, 5.1) ConvF(4.74, 4.74, 4.74) ; Calibrated: 2007/3/20 Calibrated: 2007/11/20

- Sensor-Surface: 3mm (Mechanical Surface Detection) Sensor-Surface: 4mm (Mechanical Surface Detection)

- Electronics: DAE3 Sn579; Calibrated: 2007/3/23

- Phantom: SAM 12; Type: SAM V4.0; Serial: TP 1202

- Measurement SW: DASY4, V4.7 Build 53; Postprocessing SW: SEMCAD, V1.8 Build 172

Tilt Position - Low Channel 36/Area Scan (9x19x1): Measurement grid: dx=10mm, dy=10mm
Maximum value of SAR (measured) = 1.28 mW/g

Tilt Position - Low Channel 36/Zoom Scan (8x8x8)/Cube 0: Measurement grid: dx=4.3mm, dy=4.3mm, dz=3mm

Reference Value = 9.92 V/m

Peak SAR (extrapolated) = 3.93 W/kg

SAR(1 g) = 1.15 mW/g; SAR(10 g) = 0.386 mW/g

Maximum value of SAR (measured) = 1.36 mW/g

Tilt position - High Channel 810/Zoom Scan (7x7x7) (7x7x7)/Cube 0: Measurement grid: dx=5mm, dy=5mm, dz=5mm

Reference Value = 12.6 V/m

Peak SAR (extrapolated) = 0.965 W/kg

SAR(1 g) = 0.550 mW/g; SAR(10 g) = 0.304 mW/g

Maximum value of SAR (measured) = 0.599 mW/g

Tilt position - Low Channel 0/Zoom Scan (7x7x7) (7x7x7)/Cube 0: Measurement grid:

dx=5mm, dy=5mm, dz=5mm

Reference Value = 0.440 V/m

Peak SAR (extrapolated) = 0.004 W/kg

SAR(1 g) = 0.000773 mW/g; SAR(10 g) = 0.000272 mW/g

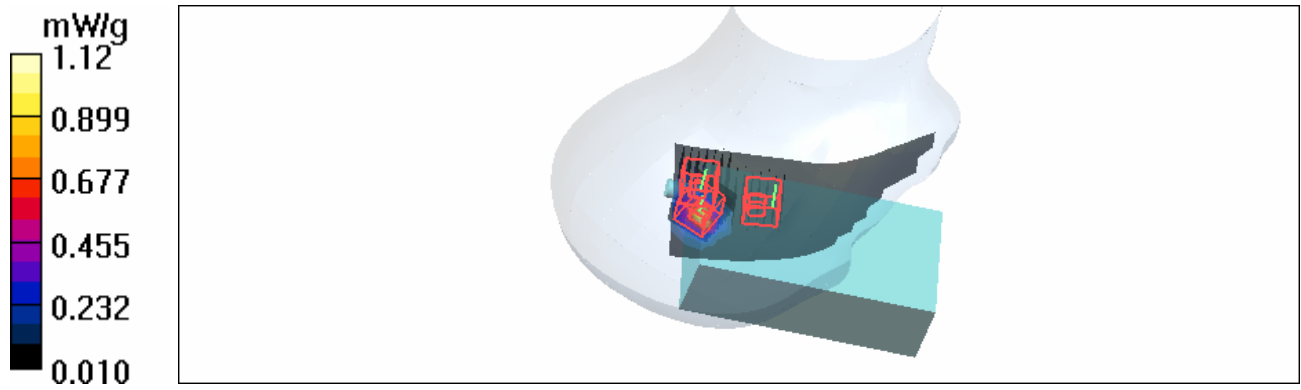

Test Laboratory: Advance Data Technology

M12- Co-located-Right Head-Tilt-11a Ch36+WCDMA Ch9400+BT Ch0

DUT: EDA ; Type: MC7596 ; Test Frequency: 5180 MHz Frequency: 1880 MHz Frequency: 2402 MHz

Communication System: 802.11a Communication System: WCDMA1900 Communication System: Bluetooth ; Frequency: 5180 MHz Frequency: 1880 MHz Frequency: 2402 MHz; Duty Cycle: 1:1 Medium: HSL5800 Medium: HSL1900 Medium: HSL2450 Medium parameters used: $f = 5180$ MHz; $\sigma = 4.64$ mho/m; $\epsilon_r = 37.1$; $\rho = 1000$ kg/m³ Medium parameters used: $f = 1880$ MHz; $\sigma = 1.41$ mho/m; $\epsilon_r = 40.2$; $\rho = 1000$ kg/m³ Medium parameters used: $f = 2402$ MHz; $\sigma = 1.78$ mho/m; $\epsilon_r = 40.5$; $\rho = 1000$ kg/m³ ; Liquid level: 154 mm
Phantom section: Right Section ; DUT test position : Tilt ; Modulation type: BPSK
Antenna type : PIFA Antenna ; Air temp. : 22.5 degrees ; Liquid temp. : 21.4 degrees

DASY4 Configuration:

- Probe: EX3DV3 - SN3506 Probe: ET3DV6 - SN1790 ; ConvF(4.92, 4.92, 4.92)ConvF(5.1, 5.1, 5.1)ConvF(4.74, 4.74, 4.74) ; Calibrated: 2007/3/20 Calibrated: 2007/11/20
- Sensor-Surface: 3mm (Mechanical Surface Detection) Sensor-Surface: 4mm (Mechanical Surface Detection)
- Electronics: DAE3 Sn579; Calibrated: 2007/3/23
- Phantom: SAM 12; Type: SAM V4.0; Serial: TP 1202
- Measurement SW: DASY4, V4.7 Build 53; Postprocessing SW: SEMCAD, V1.8 Build 172

Tilt Position - Low Channel 36/Area Scan (9x19x1): Measurement grid: dx=10mm, dy=10mm
Maximum value of SAR (measured) = 1.28 mW/g

Tilt Position - Low Channel 36/Zoom Scan (8x8x8)/Cube 0: Measurement grid: dx=4.3mm, dy=4.3mm, dz=3mm
Reference Value = 9.92 V/m
Peak SAR (extrapolated) = 3.93 W/kg
SAR(1 g) = 1.15 mW/g; SAR(10 g) = 0.386 mW/g
Maximum value of SAR (measured) = 1.36 mW/g

Tilt position -Mid Channel 9400/Zoom Scan (7x7x7) (7x7x7)/Cube 0: Measurement grid: dx=5mm, dy=5mm, dz=5mm
Reference Value = 12.0 V/m
Peak SAR (extrapolated) = 1.14 W/kg
SAR(1 g) = 0.654 mW/g; SAR(10 g) = 0.364 mW/g
Maximum value of SAR (measured) = 0.716 mW/g

Tilt position - Low Channel 0/Zoom Scan (7x7x7) (7x7x7)/Cube 0: Measurement grid: dx=5mm, dy=5mm, dz=5mm
Reference Value = 0.440 V/m
Peak SAR (extrapolated) = 0.004 W/kg

SAR(1 g) = **0.000773** mW/g; SAR(10 g) = 0.000272 mW/g

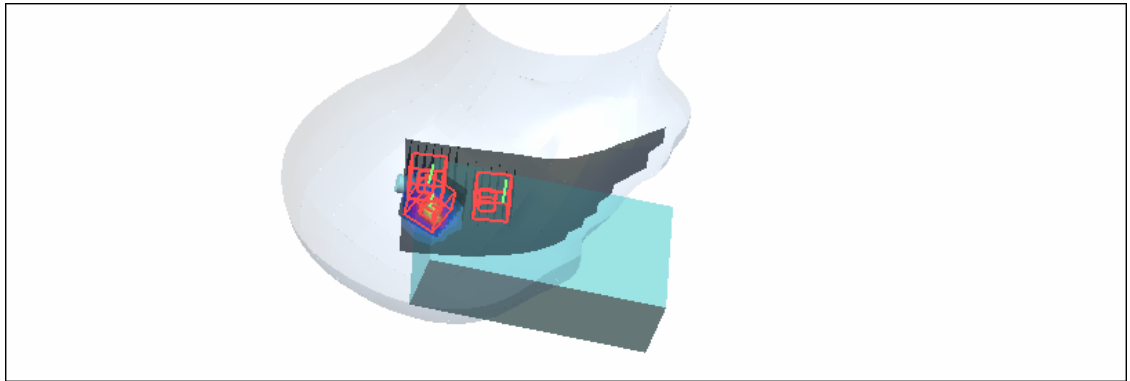
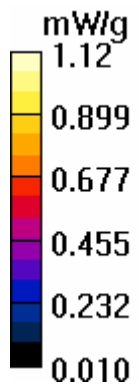

Test Laboratory: Advance Data Technology

M13- Co-located-BodyWorn-11a Ch52+GSM850 Ch251+BT Ch0

DUT: EDA ; Type: MC7596 ; Test Frequency: 5260 MHz Frequency: 848.8 MHz Frequency: 2402 MHz

Communication System: 802.11a Communication System: PCS 850 Communication System: Bluetooth ;
Frequency: 5260 MHz Frequency: 848.8 MHz Frequency: 2402 MHz ; Duty Cycle: 1:1 Duty Cycle: 1:4
Medium: MSL5800 Medium: MSL835 Medium: MSL2450 Medium parameters used: $f = 5260$ MHz; $\sigma = 5.38$ mho/m; $\epsilon_r = 50.4$; $\rho = 1000$ kg/m³ Medium parameters used: $f = 848.8$ MHz; $\sigma = 1.01$ mho/m; $\epsilon_r = 56.3$; $\rho = 1000$ kg/m³ Medium parameters used: $f = 2402$ MHz; $\sigma = 1.92$ mho/m; $\epsilon_r = 53.9$; $\rho = 1000$ kg/m³ ; Liquid Level : 151 mm

Phantom section: Flat Section ; DUT test position : Body ; Modulation Type: BPSK

Separation Distance : 0 mm (The front side of the EUT to the Phantom)

Antenna Type : PIFA Antenna ; Air Temp. : 22.3 degrees ; Liquid Temp. : 21.4 degrees

DASY4 Configuration:

- Probe: EX3DV3 - SN3506 Probe: ET3DV6 - SN1790 ; ConvF(4.14, 4.14, 4.14) ConvF(6.15, 6.15, 6.15) ConvF(4.16, 4.16, 4.16) ; Calibrated: 2007/3/23 Calibrated: 2007/11/20

- Sensor-Surface: 3mm (Mechanical Surface Detection) Sensor-Surface: 4mm (Mechanical Surface Detection)

- Electronics: DAE3 Sn579 ; Calibrated: 2007/3/23

- Phantom: SAM 12 ; Type: SAM V4.0; Serial: TP 1202

- Measurement SW: DASY4, V4.7 Build 53 ; Postprocessing SW: SEMCAD, V1.8 Build 172

Mid Channel 52/Area Scan (9x19x1): Measurement grid: dx=10mm, dy=10mm

Maximum value of SAR (measured) = 0.140 mW/g

Mid Channel 52/Zoom Scan (8x8x8)/Cube 0: Measurement grid: dx=4.3mm, dy=4.3mm, dz=3mm

Reference Value = 2.65 V/m

Peak SAR (extrapolated) = 0.387 W/kg

SAR(1 g) = 0.113 mW/g; SAR(10 g) = 0.060 mW/g

Maximum value of SAR (measured) = 0.141 mW/g

High Channel 251/Zoom Scan (7x7x7) (7x7x7)/Cube 0: Measurement grid: dx=5mm, dy=5mm, dz=5mm

Reference Value = 11.9 V/m

Peak SAR (extrapolated) = 0.360 W/kg

SAR(1 g) = 0.141 mW/g; SAR(10 g) = 0.091 mW/g

Maximum value of SAR (measured) = 0.124 mW/g

Low Channel 0/Zoom Scan (7x7x7) (7x7x7)/Cube 0: Measurement grid: dx=5mm, dy=5mm, dz=5mm

Reference Value = 0.653 V/m

Peak SAR (extrapolated) = 0.001 W/kg

SAR(1 g) = **9.17e-006** mW/g; SAR(10 g) = 1.34e-006 mW/g
Maximum value of SAR (measured) = 0.002 mW/g

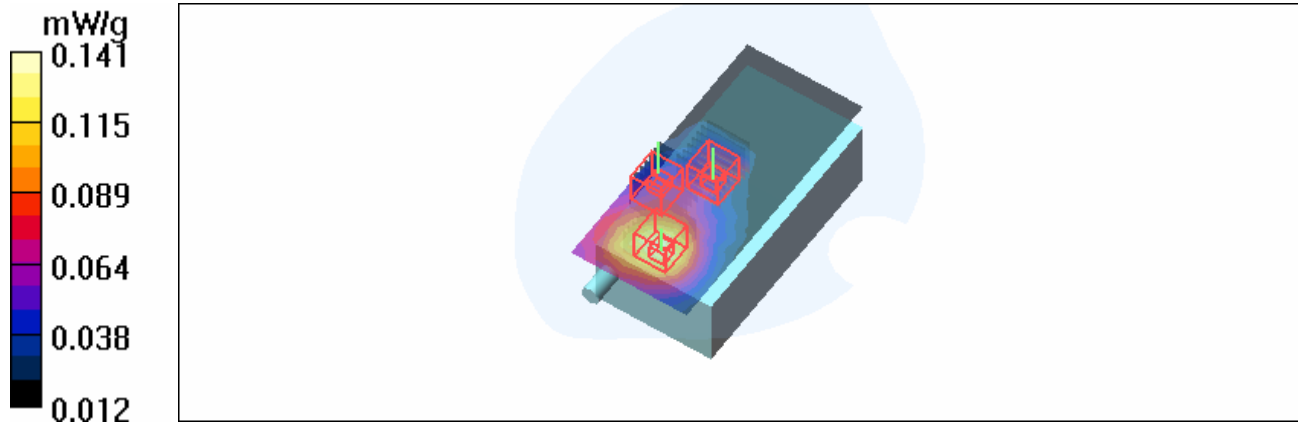

Test Laboratory: Advance Data Technology

M14- Co-located-BodyWorn-11a Ch52+WCDMA 4233+BT Ch0

DUT: EDA ; Type: MC7596 ; Test Frequency: 5260 MHz Frequency: 846.6 MHz Frequency: 2402 MHz

Communication System: 802.11a Communication System: WCDMA Communication System: Bluetooth ;
Frequency: 5260 MHz Frequency: 846.6 MHz Frequency: 2402 MHz ; Duty Cycle: 1:1
Medium: MSL5800 Medium: MSL835 Medium: MSL2450 Medium parameters used: $f = 5260$ MHz; $\sigma = 5.38$ mho/m; $\epsilon_r = 50.4$; $\rho = 1000$ kg/m³ Medium parameters used: $f = 846.6$ MHz; $\sigma = 1.01$ mho/m; $\epsilon_r = 56.3$; $\rho = 1000$ kg/m³ Medium parameters used: $f = 2402$ MHz; $\sigma = 1.92$ mho/m; $\epsilon_r = 53.9$; $\rho = 1000$ kg/m³ ; Liquid Level : 151 mm
Phantom section: Flat Section ; DUT test position : Body ; Modulation Type: BPSK
Separation Distance : 0 mm (The front side of the EUT to the Phantom)
Antenna Type : PIFA Antenna ; Air Temp. : 22.3 degrees ; Liquid Temp. : 21.4 degrees

DASY4 Configuration:

- Probe: EX3DV3 - SN3506 Probe: ET3DV6 - SN1790 ; ConvF(4.14, 4.14, 4.14)ConvF(6.15, 6.15, 6.15)ConvF(4.16, 4.16, 4.16) ; Calibrated: 2007/3/23 Calibrated: 2007/11/20
- Sensor-Surface: 3mm (Mechanical Surface Detection) Sensor-Surface: 4mm (Mechanical Surface Detection)
- Electronics: DAE3 Sn579 ; Calibrated: 2007/3/23
- Phantom: SAM 12 ; Type: SAM V4.0; Serial: TP 1202
- Measurement SW: DASY4, V4.7 Build 53 ; Postprocessing SW: SEMCAD, V1.8 Build 172

Mid Channel 52/Area Scan (9x19x1): Measurement grid: dx=10mm, dy=10mm
Maximum value of SAR (measured) = 0.140 mW/g

Mid Channel 52/Zoom Scan (8x8x8)/Cube 0: Measurement grid: dx=4.3mm, dy=4.3mm, dz=3mm

Reference Value = 2.65 V/m

Peak SAR (extrapolated) = 0.387 W/kg

SAR(1 g) = 0.113 mW/g; SAR(10 g) = 0.060 mW/g

Maximum value of SAR (measured) = 0.141 mW/g

High Channel 4233/Zoom Scan (7x7x7) (7x7x7)/Cube 0: Measurement grid: dx=5mm, dy=5mm, dz=5mm

Reference Value = 7.14 V/m

Peak SAR (extrapolated) = 0.055 W/kg

SAR(1 g) = 0.045 mW/g; SAR(10 g) = 0.0354 mW/g

Low Channel 0/Zoom Scan (7x7x7) (7x7x7)/Cube 0: Measurement grid: dx=5mm, dy=5mm, dz=5mm

Reference Value = 0.653 V/m

Peak SAR (extrapolated) = 0.001 W/kg

SAR(1 g) = **9.17e-006** mW/g; SAR(10 g) = 1.34e-006 mW/g
Maximum value of SAR (measured) = 0.002 mW/g

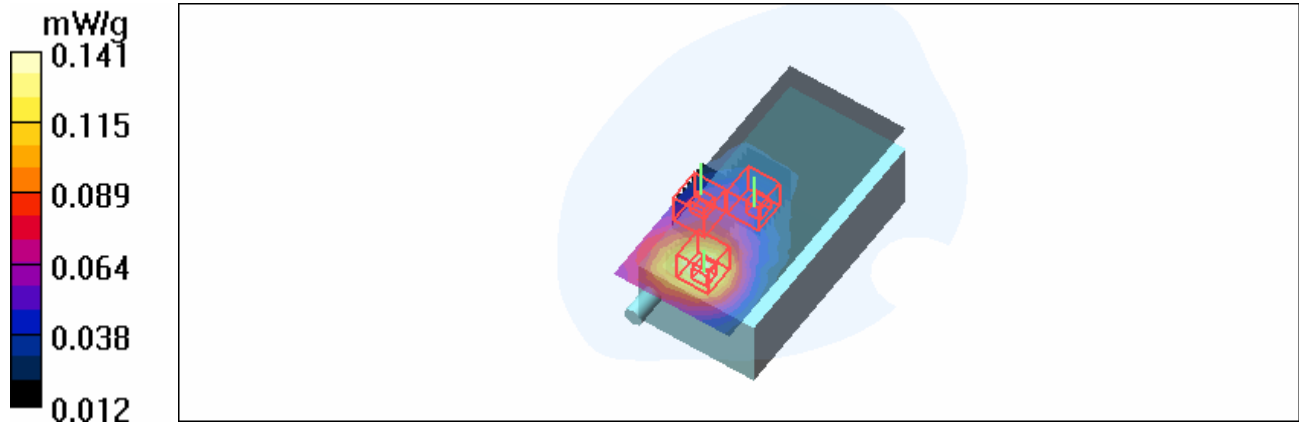

Test Laboratory: Advance Data Technology

M15- Co-located-BodyWorn-11a Ch52+PCS1900 Ch661+BT Ch0

DUT: EDA ; Type: MC7596 ; Test Frequency: 5260 MHz Frequency: 1880 MHz Frequency: 2402 MHz

Communication System: 802.11a Communication System: PCS 1900 Communication System: Bluetooth ; Frequency: 5260 MHz Frequency: 1880 MHz Frequency: 2402 MHz ; Duty Cycle: 1:1 Duty Cycle: 1:8.3 Medium: MSL5800 Medium: MSL1900 Medium: MSL2450 Medium parameters used: $f = 5260$ MHz; $\sigma = 5.38$ mho/m; $\epsilon_r = 50.4$; $\rho = 1000$ kg/m³ Medium parameters used: $f = 1880$ MHz; $\sigma = 1.52$ mho/m; $\epsilon_r = 54.7$; $\rho = 1000$ kg/m³ Medium parameters used: $f = 2402$ MHz; $\sigma = 1.92$ mho/m; $\epsilon_r = 53.9$; $\rho = 1000$ kg/m³ ; Liquid Level : 151 mm

Phantom section: Flat Section ; DUT test position : Body ; Modulation Type: BPSK

Separation Distance : 0 mm (The front side of the EUT to the Phantom)

Antenna Type : PIFA Antenna ; Air Temp. : 22.3 degrees ; Liquid Temp. : 21.4 degrees

DASY4 Configuration:

- Probe: EX3DV3 - SN3506Probe: ET3DV6 - SN1790 ; ConvF(4.14, 4.14, 4.14)ConvF(4.58, 4.58, 4.58)ConvF(4.16, 4.16, 4.16) ; Calibrated: 2007/3/23Calibrated: 2007/11/20

- Sensor-Surface: 3mm (Mechanical Surface Detection)Sensor-Surface: 4mm (Mechanical Surface Detection)

- Electronics: DAE3 Sn579 ; Calibrated: 2007/3/23

- Phantom: SAM 12 ; Type: SAM V4.0; Serial: TP 1202

- Measurement SW: DASY4, V4.7 Build 53 ; Postprocessing SW: SEMCAD, V1.8 Build 172

Mid Channel 52/Area Scan (9x19x1): Measurement grid: dx=10mm, dy=10mm

Maximum value of SAR (measured) = 0.140 mW/g

Mid Channel 52/Zoom Scan (8x8x8)/Cube 0: Measurement grid: dx=4.3mm, dy=4.3mm, dz=3mm

Reference Value = 2.65 V/m

Peak SAR (extrapolated) = 0.387 W/kg

SAR(1 g) = 0.113 mW/g; SAR(10 g) = 0.060 mW/g

Maximum value of SAR (measured) = 0.141 mW/g

Mid Channel 661/Zoom Scan (7x7x7) (7x7x7)/Cube 0: Measurement grid: dx=5mm, dy=5mm, dz=5mm

Reference Value = 4.04 V/m

Peak SAR (extrapolated) = 0.064 W/kg

SAR(1 g) = 0.040 mW/g; SAR(10 g) = 0.026 mW/g

Maximum value of SAR (measured) = 0.042 mW/g

Mid Channel 661/Zoom Scan (7x7x7) (7x7x7)/Cube 1: Measurement grid: dx=5mm, dy=5mm, dz=5mm

Reference Value = 4.67 V/m

Peak SAR (extrapolated) = 0.055 W/kg

SAR(1 g) = 0.034 mW/g; SAR(10 g) = 0.022 mW/g
Maximum value of SAR (measured) = 0.037 mW/g

Low Channel 0/Zoom Scan (7x7x7) (7x7x7)/Cube 0: Measurement grid: dx=5mm, dy=5mm, dz=5mm

Reference Value = 0.653 V/m

Peak SAR (extrapolated) = 0.001 W/kg

SAR(1 g) = 9.17e-006 mW/g; SAR(10 g) = 1.34e-006 mW/g

Maximum value of SAR (measured) = 0.002 mW/g

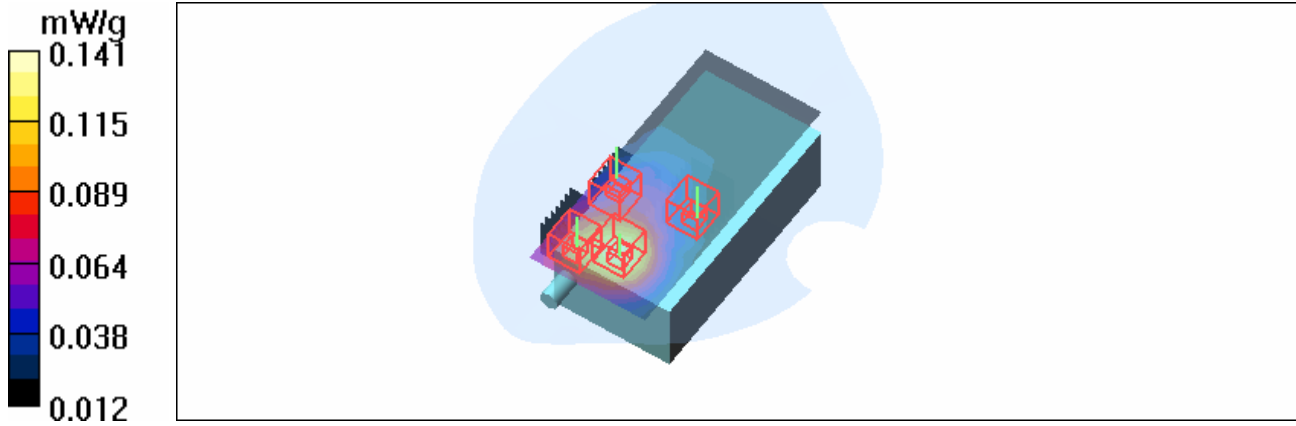

Test Laboratory: Advance Data Technology

M16- Co-located-BodyWorn-11a Ch52+WCDMA Ch9400+BT Ch0

DUT: EDA ; Type: MC7596 ; Test Frequency: 5260 MHz Frequency: 1880 MHz Frequency: 2402 MHz

Communication System: 802.11a Communication System: WCDMA1900 Communication System: Bluetooth ; Frequency: 5260 MHz Frequency: 1880 MHz Frequency: 2402 MHz ; Duty Cycle: 1:1 Medium: MSL5800 Medium: MSL1900 Medium: MSL2450 Medium parameters used: $f = 5260$ MHz; $\sigma = 5.38$ mho/m; $\epsilon_r = 50.4$; $\rho = 1000$ kg/m³ Medium parameters used: $f = 1880$ MHz; $\sigma = 1.52$ mho/m; $\epsilon_r = 54.7$; $\rho = 1000$ kg/m³ Medium parameters used: $f = 2402$ MHz; $\sigma = 1.92$ mho/m; $\epsilon_r = 53.9$; $\rho = 1000$ kg/m³ ; Liquid Level : 151 mm

Phantom section: Flat Section ; DUT test position : Body ; Modulation Type: BPSK

Separation Distance : 0 mm (The front side of the EUT to the Phantom)

Antenna Type : PIFA Antenna ; Air Temp. : 22.3 degrees ; Liquid Temp. : 21.4 degrees

DASY4 Configuration:

- Probe: EX3DV3 - SN3506 Probe: ET3DV6 - SN1790 ; ConvF(4.14, 4.14, 4.14)ConvF(4.58, 4.58, 4.58)ConvF(4.16, 4.16, 4.16) ; Calibrated: 2007/3/23 Calibrated: 2007/11/20

- Sensor-Surface: 3mm (Mechanical Surface Detection) Sensor-Surface: 4mm (Mechanical Surface Detection)

- Electronics: DAE3 Sn579 ; Calibrated: 2007/3/23

- Phantom: SAM 12 ; Type: SAM V4.0; Serial: TP 1202

- Measurement SW: DASY4, V4.7 Build 53 ; Postprocessing SW: SEMCAD, V1.8 Build 172

Mid Channel 52/Area Scan (9x19x1): Measurement grid: dx=10mm, dy=10mm

Maximum value of SAR (measured) = 0.140 mW/g

Mid Channel 52/Zoom Scan (8x8x8)/Cube 0: Measurement grid: dx=4.3mm, dy=4.3mm, dz=3mm

Reference Value = 2.65 V/m

Peak SAR (extrapolated) = 0.387 W/kg

SAR(1 g) = 0.113 mW/g; SAR(10 g) = 0.060 mW/g

Maximum value of SAR (measured) = 0.141 mW/g

Mid Channel 9400/Zoom Scan (7x7x7) (7x7x7)/Cube 0: Measurement grid: dx=5mm, dy=5mm, dz=5mm

Reference Value = 3.96 V/m

Peak SAR (extrapolated) = 0.065 W/kg

SAR(1 g) = 0.044 mW/g; SAR(10 g) = 0.028 mW/g

Maximum value of SAR (measured) = 0.045 mW/g

Mid Channel 9400/Zoom Scan (7x7x7) (7x7x7)/Cube 1: Measurement grid: dx=5mm, dy=5mm, dz=5mm

Reference Value = 3.85 V/m

Peak SAR (extrapolated) = 0.044 W/kg

SAR(1 g) = 0.028 mW/g; SAR(10 g) = 0.018 mW/g
Maximum value of SAR (measured) = 0.030 mW/g

Low Channel 0/Zoom Scan (7x7x7) (7x7x7)/Cube 0: Measurement grid: dx=5mm, dy=5mm, dz=5mm

Reference Value = 0.653 V/m

Peak SAR (extrapolated) = 0.001 W/kg

SAR(1 g) = 9.17e-006 mW/g; SAR(10 g) = 1.34e-006 mW/g

Maximum value of SAR (measured) = 0.002 mW/g

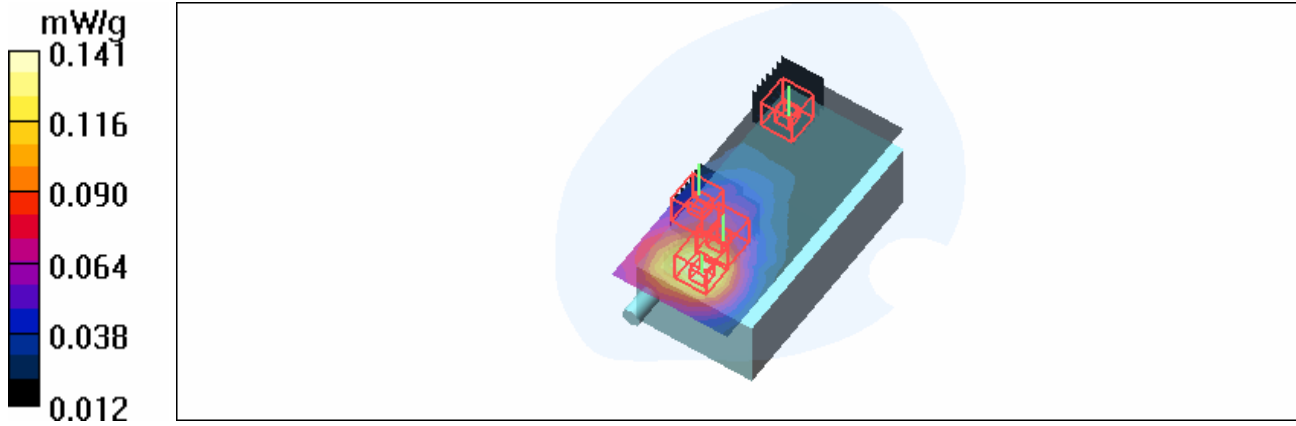



APPENDIX B:

Chapter 30

Multiband Evaluation

30.1 Introduction

Wireless devices exist that can transmit at multiple frequencies at the same time. An example of this is a cellular telephone and PDA combination that can simultaneously transmit a cellular telephone signal (e.g., at 900 MHz) and a wireless LAN signal (e.g., at 2450 MHz). It is possible that such a device may be compliant with the regulatory SAR limit at each frequency while the composite SAR from simultaneous transmission is above the limit. Therefore, the accurate determination of the SAR in this situation is important. Given that the tissue simulating liquid and the probe calibration are frequency dependent, and given that existing SAR measurement systems are unable to separate the frequency components of a signal, it is not possible to accurately measure the SAR from such a transmitter using one measurement in one liquid.

DASY4 therefore provides the possibility to perform such Multiband Evaluations according to the latest standards, e.g., [1] using the Volume Scan job as well as appropriate routines for the Postprocessing.

30.2 Multiband Measurements

The Volume Scan job described in Section 7.2.11 **Volume Scan job** allows to conduct the measurement of volumes with sufficient spatial extend such as outlined in the procedure proposed in [1].

The resulting measurement jobs can be finally evaluated and combined within the SEMCAD Postprocessor.

30.3 Multiband Data Extractions

In order to extract and process measurements within different frequency bands, the SEMCAD Postprocessor allows to combine and subsequently superpose these measurement data in the Chart Manager.

The appropriate process is outlined as follows:

1. Via drag-and-drop, the quantities to be combined can be added to the Chart Manager.

Note: Since different media were used at measuring the various bands, the results from the different Programs need to be added to one single Chart Manager. Therefore, the user can open two (or more) instances of SEMCAD, and drag-drop a specific result from one SEMCAD instance to the Chart Manager of another one.

Note: The measurement grids of the jobs which should be combined in the Post-processor should be the same, i.e., should contain the same number of points located approximately at the same locations.

2. Via multiple selection within the Chart Manager list, the appropriate items to be combined can be chosen. By use of the **Shift** or **Ctrl** keys on the keyboard in addition to mouse clicking in order an appropriate set of items is selected.

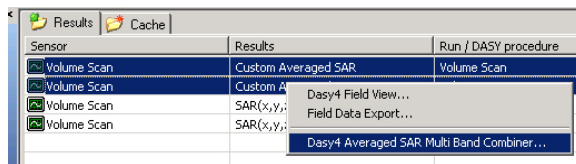

Application of the Multiband extraction to a set of items in the Chart Manager.

Note: In order to evaluate and combine Averaged SAR, the Custom Averaged SAR result field should be selected.

3. In a next step, the kind of viewer to be used for the visualization or the data export, can be selected.

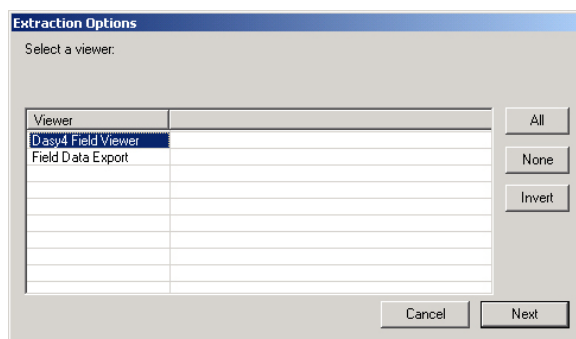

Selection of a viewer type in the Extraction Options dialogue.

4. In a final step, the results are displayed graphically and by numbers in the selected viewer or are exported as defined by the user.

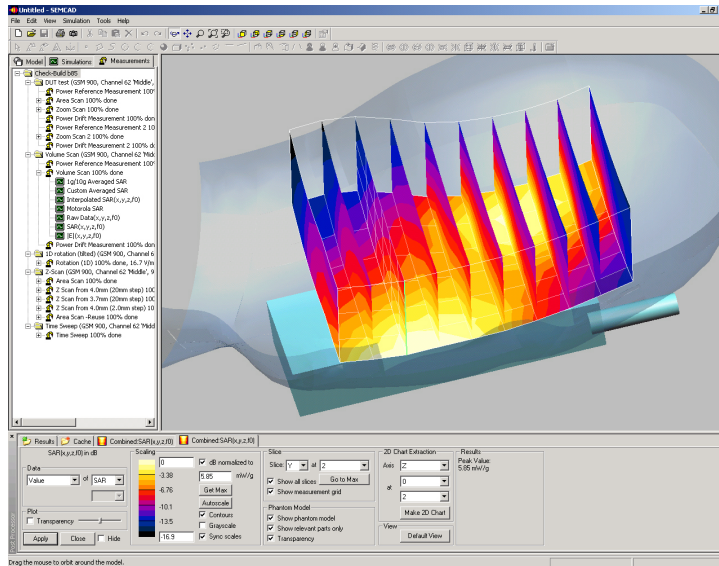

Display of results (3D Volume Scan) from the superposition of measured data in the viewer.

Note: For the Volume Scan job, in addition to the common quantities, SEMCAD allows the extraction of the Total Absorbed Power in the medium. This will be extracted for the Averaged and Interpolated SAR result fields.

Note: In order to perform a printout of the combined measurement data, please use the MultibandPrintout.htm print template provided in the appropriate folder on the DASY4 CD.