



FCC TEST REPORT (15.407)

REPORT NO.: RF970123L04-2

MODEL NO.: MC7596

RECEIVED: Jan. 23, 2008

TESTED: Feb. 21 ~ Feb. 27, 2008

ISSUED: Feb. 27, 2008

APPLICANT: Symbol Technologies, Inc.

ADDRESS: One Symbol Plaza, Holtsville, NY
11742-1300 USA

ISSUED BY: Advance Data Technology Corporation

LAB ADDRESS: No. 47, 14th Ling, Chia Pau Tsuen, Lin Kou
Hsiang 244, Taipei Hsien, Taiwan, R.O.C.

TEST LOCATION: No. 19, Hwa Ya 2nd Rd., Kwei Shan Hsiang,
Taoyuan Hsien 333, Taiwan, R.O.C.

This test report consists of 80 pages in total. It may be duplicated completely for legal use with the approval of the applicant. It should not be reproduced except in full, without the written approval of our laboratory. The client should not use it to claim product endorsement by TAF, A2LA or any government agencies. The test results in the report only apply to the tested sample.



TABLE OF CONTENTS

1.	CERTIFICATION	4
2.	SUMMARY OF TEST RESULTS	5
2.1	MEASUREMENT UNCERTAINTY	5
3.	GENERAL INFORMATION	6
3.1	GENERAL DESCRIPTION OF EUT	6
3.2	DESCRIPTION OF TEST MODES	8
3.2.1	CONFIGURATION OF SYSTEM UNDER TEST	9
3.2.2	TEST MODE APPLICABILITY AND TESTED CHANNEL DETAIL	10
3.3	GENERAL DESCRIPTION OF APPLIED STANDARDS	12
3.4	DESCRIPTION OF SUPPORT UNITS	12
4.	TEST TYPES AND RESULTS	13
4.1	RADIATED EMISSION MEASUREMENT	13
4.1.1	LIMITS OF RADIATED EMISSION MEASUREMENT	13
4.1.2	LIMITS OF UNWANTED EMISSION OUT OF THE RESTRICTED BANDS	13
4.1.3	TEST INSTRUMENTS	14
4.1.4	TEST PROCEDURES	15
4.1.5	DEVIATION FROM TEST STANDARD	15
4.1.6	TEST SETUP	16
4.1.7	EUT OPERATING CONDITION	16
4.1.8	TEST RESULTS	17
4.2	CONDUCTED EMISSION MEASUREMENT	28
4.2.1	LIMITS OF CONDUCTED EMISSION MEASUREMENT	28
4.2.2	TEST INSTRUMENTS	28
4.2.3	TEST PROCEDURES	29
4.2.4	DEVIATION FROM TEST STANDARD	29
4.2.5	TEST SETUP	30
4.2.6	EUT OPERATING CONDITIONS	30
4.2.7	TEST RESULTS	31
4.3	PEAK TRANSMIT POWER MEASUREMENT	35
4.3.1	LIMITS OF PEAK TRANSMIT POWER MEASUREMENT	35
4.3.2	TEST INSTRUMENTS	35
4.3.3	TEST PROCEDURE	35
4.3.4	DEVIATION FROM TEST STANDARD	36
4.3.5	TEST SETUP	36
4.3.6	EUT OPERATING CONDITIONS	36
4.3.7	TEST RESULTS	37
4.4	PEAK POWER EXCURSION MEASUREMENT	49
4.4.1	LIMITS OF PEAK POWER EXCURSION MEASUREMENT	49
4.4.2	TEST INSTRUMENTS	49
4.4.3	TEST PROCEDURE	49
4.4.4	DEVIATION FROM TEST STANDARD	50
4.4.5	TEST SETUP	50
4.4.6	EUT OPERATING CONDITIONS	50
4.4.7	TEST RESULTS	51



4.5	PEAK POWER SPECTRAL DENSITY MEASUREMENT	57
4.5.1	LIMITS OF PEAK POWER SPECTRAL DENSITY MEASUREMENT	57
4.5.2	TEST INSTRUMENTS	57
4.5.3	TEST PROCEDURES	57
4.5.4	DEVIATION FROM TEST STANDARD	57
4.5.5	TEST SETUP	58
4.5.6	EUT OPERATING CONDITIONS	58
4.5.7	TEST RESULTS	59
4.6	FREQUENCY STABILITY	65
4.6.1	LIMITS OF FREQUENCY STABILITY MEASUREMENT	65
4.6.2	TEST INSTRUMENTS	65
4.6.3	TEST PROCEDURE	65
4.6.4	DEVIATION FROM TEST STANDARD	66
4.6.5	TEST SETUP	66
4.6.6	EUT OPERATING CONDITION	66
4.6.7	TEST RESULTS	67
4.7	BAND EDGES MEASUREMENT	68
4.7.1	TEST INSTRUMENTS	68
4.7.2	TEST PROCEDURE	68
4.7.3	EUT OPERATING CONDITION	68
4.7.4	TEST RESULTS	68
4.8	ANTENNA REQUIREMENT	77
4.8.1	STANDARD APPLICABLE	77
4.8.2	ANTENNA CONNECTED CONSTRUCTION	77
5.	PHOTOGRAPHS OF THE TEST CONFIGURATION	78
6.	INFORMATION ON THE TESTING LABORATORIES	79
7.	APPENDIX A - MODIFICATIONS RECORDERS FOR ENGINEERING CHANGES TO THE EUT BY THE LAB	80



1. CERTIFICATION

PRODUCT: EDA (Enterprise Digital Assistant)

MODEL: MC7596

BRAND: Symbol

APPLICANT: Symbol Technologies, Inc.

TESTED: Feb. 21 ~ Feb. 27, 2008

TEST SAMPLE: ENGINEERING SAMPLE

STANDARDS: FCC Part 15, Subpart E (Section 15.407)

ANSI C63.4-2003

The above equipment (Model: MC7596) has been tested by **Advance Data Technology Corporation**, and found compliance with the requirement of the above standards. The test record, data evaluation & Equipment Under Test (EUT) configurations represented herein are true and accurate accounts of the measurements of the sample's EMC characteristics under the conditions specified in this report.

PREPARED BY : Peggy Chen , **DATE:** Feb. 27, 2008
Peggy Chen / Specialist

TECHNICAL ACCEPTANCE : Long Chen , **DATE:** Feb. 27, 2008
Responsible for RF Long Chen / Senior Engineer

APPROVED BY : Gary Chang , **DATE:** Feb. 27, 2008
Gary Chang / Assistant Manager

2. SUMMARY OF TEST RESULTS

The EUT has been tested according to the following specifications:

APPLIED STANDARD: FCC PART 15, SUBPART E (SECTION 15.407)			
STANDARD SECTION	TEST TYPE AND LIMIT	RESULT	REMARK
15.407(b)(5)	AC Power Conducted Emission	PASS	Meet the requirement of limit. Minimum passing margin is -19.71dB at 0.171MHz.
15.407(b)(1/2/3) (b)(5)	Electric Field Strength Spurious Emissions, 30MHz ~ 40000MHz	PASS	Meet the requirement of limit. Minimum passing margin is -8.19dB at 11200.00MHz.
15.407(a)(1/2/3)	Peak Transmit Power	PASS	Meet the requirement of limit.
15.407(a)(6)	Peak Power Excursion	PASS	Meet the requirement of limit.
15.407(a)(1/2/3)	Peak Power Spectral Density	PASS	Meet the requirement of limit.
15.407(g)	Frequency Stability	PASS	Meet the requirement of limit.

2.1 MEASUREMENT UNCERTAINTY

Where relevant, the following measurement uncertainty levels have been estimated for tests performed on the EUT as specified in CISPR 16-4-2:

MEASUREMENT	FREQUENCY	UNCERTAINTY
Conducted emissions	9kHz~30MHz	2.44 dB
Radiated emissions	30MHz ~ 200MHz	2.93 dB
	200MHz ~1000MHz	2.95 dB
	1GHz ~ 18GHz	2.26 dB
	18GHz ~ 40GHz	1.94 dB

This uncertainty represents an expanded uncertainty expressed at approximately the 95% confidence level using a coverage factor of $k = 2$.

3. GENERAL INFORMATION

3.1 GENERAL DESCRIPTION OF EUT

EUT	EDA (Enterprise Digital Assistant)
MODEL NO.	MC7596
FCC ID	H9PMC7596
POWER SUPPLY	3.7Vdc from rechargeable lithium battery 5.4Vdc from power adapter
MODULATION TYPE	Wireless LAN: CCK, DQPSK, DBPSK for DSSS 64QAM, 16QAM, QPSK, BPSK for OFDM Bluetooth: GFSK, $\pi/4$ -DQPSK, 8DPSK GPS: C/A code
MODULATION TECHNOLOGY	Wireless LAN: DSSS, OFDM Bluetooth: FHSS
TRANSFER RATE	Wireless LAN: 802.11b: 11, 5.5, 2, 1Mbps 802.11g: up to 54Mbps 802.11a: 54, 48, 36, 24, 18, 12, 9, 6Mbps Bluetooth: 1/2/3Mbps GPS: 50 bps
FREQUENCY RANGE	Wireless LAN: 2.4GHz: 2400 ~ 2483.5MHz 5.0GHz: 5150 ~ 5350MHz & 5470 ~ 5725MHz & 5725 ~ 5850MHz Bluetooth: 2402 ~ 2480MHz GPS: 1575.42 MHz
NUMBER OF CHANNEL	Wireless LAN: 2.4GHz: 11 for 802.11b, 802.11g 5.0GHz: 5150 ~ 5350MHz: 8 for 802.11a 5470 ~ 5725MHz: 11 for 802.11a 5725 ~ 5850MHz: 5 for 802.11a Bluetooth: 79 GPS: 1
OUTPUT POWER	Wireless LAN: 101.86mW for 2400 ~ 2483.5MHz 16.75mW for 5150 ~ 5350MHz 26.79mW for 5470 ~ 5725MHz 81.28mW for 5725 ~ 5850MHz Bluetooth: 2.04mW

ANTENNA TYPE(S)	Wireless LAN: Inverted F antenna Planar inverted antenna Bluetooth: Chip antenna		
MAX. ANTENNA GAIN	2.4GHz: 2.5dBi	5.0GHz: 3.5dBi	Bluetooth: -1.5dBi
DATA CABLE	NA		
I/O PORTS	Refer to user's manual		
ACCESSORY DEVICES	NA		

NOTE:

1. The models as identified below are identical to each other except of the following options:

- Keypad: Numeric / QWERTY
- Barcode reader: 1D laser scanner / 2D Imager

BRAND	MODEL	DESCRIPTION
Symbol	MC7596	HSDPA 1D Numeric
Symbol	MC7596	HSDPA 2D QWERTY
**the worst case had been marked by boldface.		

2. The EUT is an EDA (Enterprise Digital Assistant). The functions of EUT listed as below:

	TEST STANDARD	REFERENCE REPORT
WLAN 802.11a/b/g (802.11a follows standard 15.247)	FCC Part 15	RF970123L04
WLAN 802.11a (follows standard 15.407)		RF970123L04-2
BLUETOOTH		RF970123L04-3
GSM 850 / WCDMA 850	FCC Part 22	RF970123L04-1
PCS 1900 / WCDMA 1900	FCC Part 24	RF970123L04-4

3. The EUT has one lithium battery listed as below:

LI-LON BATTERY	
BRAND:	MOTOROLA
MODEL:	82-71364-05 Rev A
RATING:	3.7Vdc, 3600mAh

4. The following accessories are for support units only.

PRODUCT	BRAND	MODEL	DESCRIPTION
RS232 charging cable	Motorola	25-102776-01R	1.2m non-shielded cable with one core
USB charging cable	Motorola	25-102775-01R	1.5m shielded cable with one core
Headset	Motorola	50-11300-050R	VR10 headset 0.8m non-shielded cable with one core
Power Supply Adaptor	Motorola	EADP-16BB A	I/P: 100-240Vac, 50-60Hz, 0.4A O/P: 5.4Vdc, 3A 1.8m non-shielded cable without core



5. The EUT operates in both the 5GHz and 2.4GHz Bands and compatibility with 802.11a and 802.11b, 802.11g technology.
6. The EUT operates in the 2.4GHz/5GHz frequency spectrum with throughput of up to 54Mbps.
7. The above EUT information was declared by manufacturer and for more detailed features description, please refer to the manufacturer's specifications or user's manual.

3.2 DESCRIPTION OF TEST MODES

Operated in 5150 ~ 5350MHz

8 channels are provided to this EUT.

CHANNEL	FREQUENCY	CHANNEL	FREQUENCY
1	5180 MHz	5	5260 MHz
2	5200 MHz	6	5280 MHz
3	5220 MHz	7	5300 MHz
4	5240 MHz	8	5320 MHz

Operated in 5470 ~ 5725MHz:

11 channels are provided to this EUT.

CHANNEL	FREQUENCY	CHANNEL	FREQUENCY
1	5500 MHz	7	5620 MHz
2	5520 MHz	8	5640 MHz
3	5540 MHz	9	5660 MHz
4	5560 MHz	10	5680 MHz
5	5580 MHz	11	5700 MHz
6	5600 MHz		

3.2.1 CONFIGURATION OF SYSTEM UNDER TEST

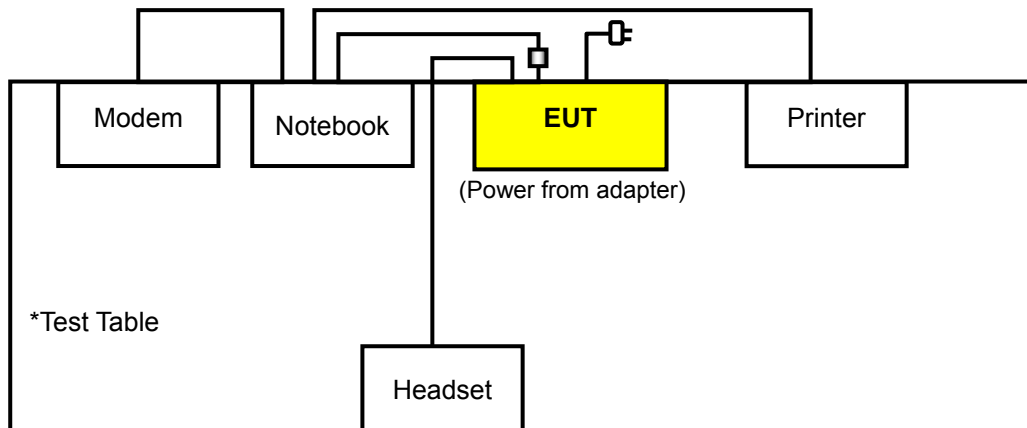

3.2.2 TEST MODE APPLICABILITY AND TESTED CHANNEL DETAIL

EUT CONFIGURE MODE	APPLICABLE TO				DESCRIPTION
	RE \geq 1G	RE<1G	PLC	APCM	
-	√	√	√	√	-

Where **RE \geq 1G**: Radiated Emission above 1GHz

RE<1G: Radiated Emission below 1GHz

PLC: Power Line Conducted Emission

APCM: Antenna Port Conducted Measurement

RADIATED EMISSION TEST (ABOVE 1GHz):

Pre-Scan has been conducted to determine the worst-case mode from all possible combinations between available modulations, data rates, XYZ axis and antenna ports (if EUT with antenna diversity architecture).

Following channel(s) was (were) selected for the final test as listed below.

MODE	FREQ. BAND	AVAILABLE CHANNEL	TESTED CHANNEL	MODULATION TECHNOLOGY	MODULATION TYPE	DATA RATE (Mbps)	AXIS
802.11a	5150-5350	1 to 8	1, 2, 4, 5, 7, 8	OFDM	BPSK	6.0	Z
802.11a	5470-5725	1 to 11	1, 6, 11	OFDM	BPSK	6.0	Z

RADIATED EMISSION TEST (BELOW 1GHz):

Pre-Scan has been conducted to determine the worst-case mode from all possible combinations between available modulations, data rates, XYZ axis and antenna ports (if EUT with antenna diversity architecture).

Following channel(s) was (were) selected for the final test as listed below.

MODE	FREQ. BAND	AVAILABLE CHANNEL	TESTED CHANNEL	MODULATION TECHNOLOGY	MODULATION TYPE	DATA RATE (Mbps)	AXIS
802.11a	5150-5350	1 to 8	8	OFDM	BPSK	6.0	Z
802.11a	5470-5725	1 to 11	6	OFDM	BPSK	6.0	Z



POWER LINE CONDUCTED EMISSION TEST:

- Pre-Scan has been conducted to determine the worst-case mode from all possible combinations between available modulations, data rates and antenna ports (if EUT with antenna diversity architecture).
- Following channel(s) was (were) selected for the final test as listed below.

MODE	FREQ. BAND	AVAILABLE CHANNEL	TESTED CHANNEL	MODULATION TECHNOLOGY	MODULATION TYPE	DATA RATE (Mbps)
802.11a	5150-5350	1 to 8	8	OFDM	BPSK	6.0
802.11a	5470-5725	1 to 11	6	OFDM	BPSK	6.0

BANDEDGE MEASUREMENT:

- Pre-Scan has been conducted to determine the worst-case mode from all possible combinations between available modulations, data rates and antenna ports (if EUT with antenna diversity architecture).
- Following channel(s) was (were) selected for the final test as listed below.

MODE	FREQ. BAND	AVAILABLE CHANNEL	TESTED CHANNEL	MODULATION TECHNOLOGY	MODULATION TYPE	DATA RATE (Mbps)
802.11a	5150-5350	1 to 8	1, 8	OFDM	BPSK	6.0
802.11a	5470-5725	1 to 11	1, 11	OFDM	BPSK	6.0

ANTENNA PORT CONDUCTED MEASUREMENT:

- Pre-Scan has been conducted to determine the worst-case mode from all possible combinations between available modulations, data rates and antenna ports (if EUT with antenna diversity architecture).
- Following channel(s) was (were) selected for the final test as listed below.

MODE	FREQ. BAND	AVAILABLE CHANNEL	TESTED CHANNEL	MODULATION TECHNOLOGY	MODULATION TYPE	DATA RATE (Mbps)
802.11a	5150-5350	1 to 8	1, 2, 4, 5, 7, 8	OFDM	BPSK	6.0
802.11a	5470-5725	1 to 11	1, 6, 11	OFDM	BPSK	6.0



3.3 GENERAL DESCRIPTION OF APPLIED STANDARDS

The EUT is a RF Product. According to the specifications of the manufacturer, it must comply with the requirements of the following standards:

FCC Part 15, Subpart E (15.407)

ANSI C63.4-2003

All test items have been performed and recorded as per the above standards.

NOTE: The EUT is also considered as a kind of computer peripheral, because the connection to computer is necessary for typical use. It has been verified to comply with the requirements of FCC Part 15, Subpart B, Class B (DoC). The test report has been issued separately.

3.4 DESCRIPTION OF SUPPORT UNITS

The EUT has been tested as an independent unit together with other necessary accessories or support units. The following support units or accessories were used to form a representative test configuration during the tests.

NO.	PRODUCT	BRAND	MODEL NO.	SERIAL NO.	FCC ID
1	NOTEBOOK COMPUTER	DELL	PP05L	12130898320	E2K24CLNS
2	PRINTER	EPSON	LQ-300+	DCGY054011	FCC DoC Approved
3	MODEM	ACEEX	1414V/3	0401008253	IFAXDM1414

NO.	SIGNAL CABLE DESCRIPTION OF THE ABOVE SUPPORT UNITS
1	1.2m shielded USB cable with one core.
2	1.8m braid shielded wire, DB25 connector, w/o core.
3	1.2m braid shielded wire, DB25 & DB9 connector, w/o core.

NOTE 1: All power cords of the above support units are non shielded (1.8m).

NOTE 2: The 1.2m USB cable with one core was supplied from client, only for test.

4. TEST TYPES AND RESULTS

4.1 RADIATED EMISSION MEASUREMENT

4.1.1 LIMITS OF RADIATED EMISSION MEASUREMENT

Emissions radiated outside of the specified bands, shall be according to the general radiated limits in 15.209 as following:

FREQUENCIES (MHz)	FIELD STRENGTH (microvolts/meter)	MEASUREMENT DISTANCE (meters)
0.009 ~ 0.490	2400/F(kHz)	300
0.490 ~ 1.705	24000/F(kHz)	30
1.705 ~ 30.0	30	30
30 ~ 88	100	3
88 ~ 216	150	3
216 ~ 960	200	3
Above 960	500	3

NOTE:

1. The lower limit shall apply at the transition frequencies.
2. Emission level (dBuV/m) = 20 log Emission level (uV/m).
3. As shown in 15.35(b), for frequencies above 1000MHz, the field strength limits are based on average detector, however, the peak field strength of any emission shall not exceed the maximum permitted average limits, specified above by more than 20dB under any condition of modulation.

4.1.2 LIMITS OF UNWANTED EMISSION OUT OF THE RESTRICTED BANDS

FREQUENCIES (MHz)	EIRP LIMIT (dBm)		EQUIVALENT FIELD STRENGTH AT 3m (dBμV/m) *NOTE 3	
	PK	AV	PK	AV
5150 ~ 5250	-7	-27	88.3	68.3
5250 ~ 5350	-7	-27	88.3	68.3
5470 ~ 5725	-7	-27	88.3	68.3

NOTE:

1. For frequencies 10MHz or greater above or below the band edge.
2. All emissions within the frequency range from the band edge to 10MHz above or below the band edge.
3. The following formula is used to convert the equipment isotropic radiated power (eirp) to field strength:

$$E = \frac{1000000\sqrt{30P}}{3} \mu\text{V/m, where P is the eirp (Watts).}$$



4.1.3 TEST INSTRUMENTS

DESCRIPTION & MANUFACTURER	MODEL NO.	SERIAL NO.	CALIBRATED UNTIL
Test Receiver ROHDE & SCHWARZ	ESCI	100424	Jul. 27, 2008
Spectrum Analyzer ROHDE & SCHWARZ	FSP40	100269	Aug. 05, 2008
BILOG Antenna SCHWARZBECK	VULB9168	9168-153	Jan. 03, 2009
HORN Antenna SCHWARZBECK	BBHA 9120 D	9120D-563	Jul. 30, 2008
HORN Antenna SCHWARZBECK	BBHA 9170	BBHA9170242	Jan. 06, 2009
Preamplifier Agilent	8449B	3008A01910	Sep. 19, 2008
Preamplifier Agilent	8447D	2944A10638	Dec. 19, 2008
RF signal cable HUBER+SUHNNER	SUCOFLEX 104	274039/223650	Nov. 07, 2008
RF signal cable Worken	8D-FB	Cable-HYCH9-01	Aug. 09, 2008
Software	ADT_Radiated_V7.6	NA	NA
Antenna Tower EMCO	2070/2080	512.835.4684	NA
Turn Table EMCO	2087-2.03	NA	NA
Antenna Tower & Turn Table Controller EMCO	2090	NA	NA
26GHz ~ 40GHz Amplifier	EM26400	07026401	Apr. 23, 2008

- NOTE:**
1. The calibration interval of the above test instruments is 12 months and the calibrations are traceable to NML/ROC and NIST/USA.
 2. The test was performed in HwaYa Chamber 9.
 3. The horn antenna and HP preamplifier (model: 8449B) are used only for the measurement of emission frequency above 1GHz if tested.
 4. The IC Site Registration No. is IC3789B-9.

4.1.4 TEST PROCEDURES

- a. The EUT was placed on the top of a rotating table 0.8 meters above the ground at a 3 meter semi-anechoic chamber. The table was rotated 360 degrees to determine the position of the highest radiation.
- b. The EUT was set 3 meters away from the interference-receiving antenna, which was mounted on the top of a variable-height antenna tower.
- c. The antenna is a broadband antenna, and its height is varied from one meter to four meters above the ground to determine the maximum value of the field strength. Both horizontal and vertical polarizations of the antenna are set to make the measurement.
- d. For each suspected emission, the EUT was arranged to its worst case and then the antenna was tuned to heights from 1 meter to 4 meters and the rotatable table was turned from 0 degrees to 360 degrees to find the maximum reading.
- e. The test-receiver system was set to Peak Detect Function and Specified Bandwidth with Maximum Hold Mode.
- f. If the emission level of the EUT in peak mode was 10dB lower than the limit specified, then testing could be stopped and the peak values of the EUT would be reported. Otherwise the emissions that did not have 10dB margin would be re-tested one by one using peak, quasi-peak or average method as specified and then reported in a data sheet.

NOTE:

1. The resolution bandwidth and video bandwidth of test receiver/spectrum analyzer is 120kHz for Peak detection (PK) and Quasi-peak detection (QP) at frequency below 1GHz.
2. The resolution bandwidth of test receiver/spectrum analyzer is 1MHz and video bandwidth is 3MHz for Peak detection at frequency above 1GHz.
3. The resolution bandwidth of test receiver/spectrum analyzer is 1 MHz and the video bandwidth is 10Hz for Average detection (AV) at frequency above 1GHz.
4. All modes of operation were investigated and the worst-case emissions are reported.

4.1.5 DEVIATION FROM TEST STANDARD

No deviation

4.1.6 TEST SETUP

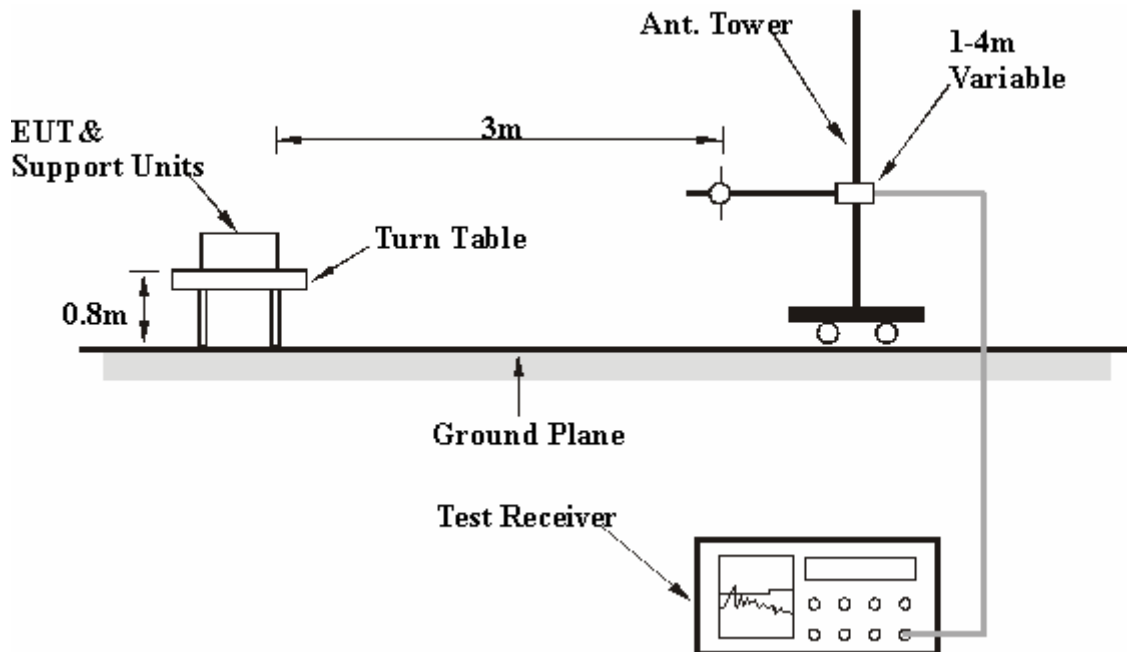

For the actual test configuration, please refer to the attached file (Test Setup Photo).

4.1.7 EUT OPERATING CONDITION

- Connected the EUT to a notebook via a USB cable and placed on a testing table.
- The notebook system run a test program (provided by manufacturer) to enable EUT under transmission condition continuously at specific channel frequency.
- The necessary accessories enable the system in full functions.



4.1.8 TEST RESULTS

ABOVE 1GHz DATA:

FOR 5150-5350MHz BAND: 802.11a OFDM MODULATION

EUT TEST CONDITION		MEASUREMENT DETAIL	
CHANNEL	Channel 1	FREQUENCY RANGE	1 ~ 40GHz
INPUT POWER (SYSTEM)	120Vac, 60 Hz	DETECTOR FUNCTION	Peak (PK) Average (AV)
ENVIRONMENTAL CONDITIONS	23deg. C, 70%RH 1002hPa	TESTED BY	Lori Chiu

ANTENNA POLARITY & TEST DISTANCE: HORIZONTAL AT 3 M								
NO.	FREQ. (MHz)	EMISSION LEVEL (dBuV/m)	LIMIT (dBuV/m)	MARGIN (dB)	ANTENNA HEIGHT (m)	TABLE ANGLE (Degree)	RAW VALUE (dBuV)	CORRECTION FACTOR (dB/m)
1	#5150.00	58.87 PK	74.00	-15.13	1.24 H	211	20.28	38.59
2	#5150.00	39.33 AV	54.00	-14.67	1.24 H	211	0.74	38.59
3	*5180.00	100.61 PK			1.24 H	211	61.97	38.64
4	*5180.00	90.09 AV			1.24 H	211	51.45	38.64
5	10360.00	57.27 PK	88.30	-31.03	1.01 H	15	8.56	48.70
6	10360.00	44.34 AV	68.30	-23.96	1.01 H	15	-4.37	48.70
ANTENNA POLARITY & TEST DISTANCE: VERTICAL AT 3 M								
NO.	FREQ. (MHz)	EMISSION LEVEL (dBuV/m)	LIMIT (dBuV/m)	MARGIN (dB)	ANTENNA HEIGHT (m)	TABLE ANGLE (Degree)	RAW VALUE (dBuV)	CORRECTION FACTOR (dB/m)
1	#5150.00	57.61 PK	74.00	-16.39	1.19 V	199	19.02	38.59
2	#5150.00	40.78 AV	54.00	-13.22	1.19 V	199	2.19	38.59
3	*5180.00	102.91 PK			1.19 V	199	64.27	38.64
4	*5180.00	92.23 AV			1.19 V	199	53.59	38.64
5	10360.00	57.87 PK	88.30	-30.43	1.03 V	25	9.16	48.70
6	10360.00	44.14 AV	68.30	-24.16	1.03 V	25	-4.57	48.70

- REMARKS:**
1. Emission level (dBuV/m) = Raw Value (dBuV) + Correction Factor (dB/m).
 2. Correction Factor (dB/m) = Antenna Factor (dB/m) + Cable Factor (dB).
 3. The other emission levels were very low against the limit.
 4. Margin value = Emission level – Limit value.
 5. “ * ”: Fundamental frequency.
 6. “ # ”: The radiated frequency falling in the restricted band.



EUT TEST CONDITION		MEASUREMENT DETAIL	
CHANNEL	Channel 2	FREQUENCY RANGE	1 ~ 40GHz
INPUT POWER (SYSTEM)	120Vac, 60 Hz	DETECTOR FUNCTION	Peak (PK) Average (AV)
ENVIRONMENTAL CONDITIONS	23deg. C, 70%RH 1002hPa	TESTED BY	Brad Wu

ANTENNA POLARITY & TEST DISTANCE: HORIZONTAL AT 3 M								
NO.	FREQ. (MHz)	EMISSION LEVEL (dBuV/m)	LIMIT (dBuV/m)	MARGIN (dB)	ANTENNA HEIGHT (m)	TABLE ANGLE (Degree)	RAW VALUE (dBuV)	CORRECTION FACTOR (dB/m)
1	*5200.00	100.19 PK			1.23 H	207	61.52	38.67
2	*5200.00	89.63 AV			1.23 H	207	50.96	38.67
3	10400.00	57.98 PK	88.30	-30.32	1.02 H	245	9.21	48.77
4	10400.00	43.97 AV	68.30	-24.33	1.02 H	245	-4.80	48.77
ANTENNA POLARITY & TEST DISTANCE: VERTICAL AT 3 M								
NO.	FREQ. (MHz)	EMISSION LEVEL (dBuV/m)	LIMIT (dBuV/m)	MARGIN (dB)	ANTENNA HEIGHT (m)	TABLE ANGLE (Degree)	RAW VALUE (dBuV)	CORRECTION FACTOR (dB/m)
1	*5200.00	103.25 PK			1.18 V	211	64.58	38.67
2	*5200.00	92.99 AV			1.18 V	211	54.32	38.67
3	10400.00	57.04 PK	88.30	-31.26	1.01 V	15	8.27	48.77
4	10400.00	44.64 AV	68.30	-23.66	1.01 V	15	-4.13	48.77

- REMARKS:**
1. Emission level (dBuV/m) = Raw Value (dBuV) + Correction Factor (dB/m).
 2. Correction Factor (dB/m) = Antenna Factor (dB/m) + Cable Factor (dB).
 3. The other emission levels were very low against the limit.
 4. Margin value = Emission level – Limit value.
 5. “ * “: Fundamental frequency.
 6. “ # “: The radiated frequency falling in the restricted band.



EUT TEST CONDITION		MEASUREMENT DETAIL	
CHANNEL	Channel 4	FREQUENCY RANGE	1 ~ 40GHz
INPUT POWER (SYSTEM)	120Vac, 60 Hz	DETECTOR FUNCTION	Peak (PK) Average (AV)
ENVIRONMENTAL CONDITIONS	23deg. C, 70%RH 1002hPa	TESTED BY	Brad Wu

ANTENNA POLARITY & TEST DISTANCE: HORIZONTAL AT 3 M								
NO.	FREQ. (MHz)	EMISSION LEVEL (dBuV/m)	LIMIT (dBuV/m)	MARGIN (dB)	ANTENNA HEIGHT (m)	TABLE ANGLE (Degree)	RAW VALUE (dBuV)	CORRECTION FACTOR (dB/m)
1	*5240.00	100.48 PK			1.24 H	210	61.77	38.71
2	*5240.00	89.91 AV			1.24 H	210	51.20	38.71
3	10480.00	58.13 PK	88.30	-30.17	1.24 H	53	9.12	49.01
4	10480.00	44.08 AV	68.30	-24.22	1.24 H	53	-4.93	49.01
ANTENNA POLARITY & TEST DISTANCE: VERTICAL AT 3 M								
NO.	FREQ. (MHz)	EMISSION LEVEL (dBuV/m)	LIMIT (dBuV/m)	MARGIN (dB)	ANTENNA HEIGHT (m)	TABLE ANGLE (Degree)	RAW VALUE (dBuV)	CORRECTION FACTOR (dB/m)
1	*5240.00	103.93 PK			1.18 V	211	65.23	38.71
2	*5240.00	93.40 AV			1.18 V	211	54.70	38.71
3	10480.00	57.23 PK	88.30	-31.07	1.03 V	56	8.22	49.01
4	10480.00	44.85 AV	68.30	-23.45	1.03 V	56	-4.16	49.01

- REMARKS:**
1. Emission level (dBuV/m) = Raw Value (dBuV) + Correction Factor (dB/m).
 2. Correction Factor (dB/m) = Antenna Factor (dB/m) + Cable Factor (dB).
 3. The other emission levels were very low against the limit.
 4. Margin value = Emission level – Limit value.
 5. “ * “: Fundamental frequency.
 6. “ # “: The radiated frequency falling in the restricted band.



EUT TEST CONDITION		MEASUREMENT DETAIL	
CHANNEL	Channel 5	FREQUENCY RANGE	1 ~ 40GHz
INPUT POWER (SYSTEM)	120Vac, 60 Hz	DETECTOR FUNCTION	Peak (PK) Average (AV)
ENVIRONMENTAL CONDITIONS	23deg. C, 70%RH 1002hPa	TESTED BY	Brad Wu

ANTENNA POLARITY & TEST DISTANCE: HORIZONTAL AT 3 M								
NO.	FREQ. (MHz)	EMISSION LEVEL (dBuV/m)	LIMIT (dBuV/m)	MARGIN (dB)	ANTENNA HEIGHT (m)	TABLE ANGLE (Degree)	RAW VALUE (dBuV)	CORRECTION FACTOR (dB/m)
1	*5260.00	100.36 PK			1.23 H	206	61.64	38.72
2	*5260.00	89.80 AV			1.23 H	206	51.08	38.72
3	10520.00	58.24 PK	88.30	-30.06	1.06 H	225	9.12	49.12
4	10520.00	44.16 AV	68.30	-24.14	1.06 H	225	-4.96	49.12
ANTENNA POLARITY & TEST DISTANCE: VERTICAL AT 3 M								
NO.	FREQ. (MHz)	EMISSION LEVEL (dBuV/m)	LIMIT (dBuV/m)	MARGIN (dB)	ANTENNA HEIGHT (m)	TABLE ANGLE (Degree)	RAW VALUE (dBuV)	CORRECTION FACTOR (dB/m)
1	*5260.00	103.70 PK			1.18 V	211	64.97	38.72
2	*5260.00	93.24 AV			1.18 V	211	54.51	38.72
3	10520.00	57.25 PK	88.30	-31.05	1.04 V	261	8.13	49.12
4	10520.00	44.92 AV	68.30	-23.38	1.04 V	261	-4.20	49.12

- REMARKS:**
1. Emission level (dBuV/m) = Raw Value (dBuV) + Correction Factor (dB/m).
 2. Correction Factor (dB/m) = Antenna Factor (dB/m) + Cable Factor (dB).
 3. The other emission levels were very low against the limit.
 4. Margin value = Emission level – Limit value.
 5. “ * “: Fundamental frequency.
 6. “ # “: The radiated frequency falling in the restricted band.



EUT TEST CONDITION		MEASUREMENT DETAIL	
CHANNEL	Channel 7	FREQUENCY RANGE	1 ~ 40GHz
INPUT POWER (SYSTEM)	120Vac, 60 Hz	DETECTOR FUNCTION	Peak (PK) Average (AV)
ENVIRONMENTAL CONDITIONS	23deg. C, 70%RH 1002hPa	TESTED BY	Brad Wu

ANTENNA POLARITY & TEST DISTANCE: HORIZONTAL AT 3 M								
NO.	FREQ. (MHz)	EMISSION LEVEL (dBuV/m)	LIMIT (dBuV/m)	MARGIN (dB)	ANTENNA HEIGHT (m)	TABLE ANGLE (Degree)	RAW VALUE (dBuV)	CORRECTION FACTOR (dB/m)
1	*5300.00	100.13 PK			1.22 H	205	61.37	38.76
2	*5300.00	89.62 AV			1.22 H	205	50.86	38.76
3	#10600.00	58.36 PK	74.00	-15.64	1.04 H	139	9.06	49.30
4	#10600.00	44.35 AV	54.00	-9.65	1.04 H	139	-4.95	49.30
ANTENNA POLARITY & TEST DISTANCE: VERTICAL AT 3 M								
NO.	FREQ. (MHz)	EMISSION LEVEL (dBuV/m)	LIMIT (dBuV/m)	MARGIN (dB)	ANTENNA HEIGHT (m)	TABLE ANGLE (Degree)	RAW VALUE (dBuV)	CORRECTION FACTOR (dB/m)
1	*5300.00	103.54 PK			1.16 V	201	64.78	38.76
2	*5300.00	93.15 AV			1.16 V	201	54.39	38.76
3	#10600.00	57.80 PK	74.00	-16.20	1.15 V	24	8.50	49.30
4	#10600.00	44.55 AV	54.00	-9.45	1.15 V	24	-4.75	49.30

- REMARKS:**
1. Emission level (dBuV/m) = Raw Value (dBuV) + Correction Factor (dB/m).
 2. Correction Factor (dB/m) = Antenna Factor (dB/m) + Cable Factor (dB).
 3. The other emission levels were very low against the limit.
 4. Margin value = Emission level – Limit value.



EUT TEST CONDITION		MEASUREMENT DETAIL	
CHANNEL	Channel 8	FREQUENCY RANGE	1 ~ 40GHz
INPUT POWER (SYSTEM)	120Vac, 60 Hz	DETECTOR FUNCTION	Peak (PK) Average (AV)
ENVIRONMENTAL CONDITIONS	23deg. C, 70%RH 1002hPa	TESTED BY	Brad Wu

ANTENNA POLARITY & TEST DISTANCE: HORIZONTAL AT 3 M								
NO.	FREQ. (MHz)	EMISSION LEVEL (dBuV/m)	LIMIT (dBuV/m)	MARGIN (dB)	ANTENNA HEIGHT (m)	TABLE ANGLE (Degree)	RAW VALUE (dBuV)	CORRECTION FACTOR (dB/m)
1	*5320.00	99.86 PK			1.21 H	208	61.08	38.78
2	*5320.00	89.31 AV			1.21 H	208	50.53	38.78
3	#5350.00	60.03 PK	74.00	-13.97	1.21 H	208	21.22	38.81
4	#5350.00	39.76 AV	54.00	-14.24	1.21 H	208	0.95	38.81
5	#10640.00	58.06 PK	74.00	-15.94	1.13 H	241	8.73	49.33
6	#10640.00	44.18 AV	54.00	-9.82	1.13 H	241	-5.15	49.33
ANTENNA POLARITY & TEST DISTANCE: VERTICAL AT 3 M								
NO.	FREQ. (MHz)	EMISSION LEVEL (dBuV/m)	LIMIT (dBuV/m)	MARGIN (dB)	ANTENNA HEIGHT (m)	TABLE ANGLE (Degree)	RAW VALUE (dBuV)	CORRECTION FACTOR (dB/m)
1	*5320.00	103.05 PK			1.16 V	200	64.27	38.78
2	*5320.00	92.61 AV			1.16 V	200	53.83	38.78
3	#5350.00	62.06 PK	74.00	-11.94	1.16 V	200	23.25	38.81
4	#5350.00	41.89 AV	54.00	-12.11	1.16 V	200	3.08	38.81
5	#10640.00	58.25 PK	74.00	-15.75	1.16 V	28	8.92	49.33
6	#10640.00	44.31 AV	54.00	-9.69	1.16 V	28	-5.02	49.33

- REMARKS:**
1. Emission level (dBuV/m) = Raw Value (dBuV) + Correction Factor (dB/m).
 2. Correction Factor (dB/m) = Antenna Factor (dB/m) + Cable Factor (dB).
 3. The other emission levels were very low against the limit.
 4. Margin value = Emission level – Limit value.
 5. “ * “: Fundamental frequency.
 6. “ # “: The radiated frequency falling in the restricted band.



FOR 5470-5725MHz BAND: 802.11a OFDM MODULATION

EUT TEST CONDITION		MEASUREMENT DETAIL	
CHANNEL	Channel 1	FREQUENCY RANGE	1 ~ 40GHz
INPUT POWER (SYSTEM)	120Vac, 60 Hz	DETECTOR FUNCTION	Peak (PK) Average (AV)
ENVIRONMENTAL CONDITIONS	23deg. C, 70%RH 1002hPa	TESTED BY	Brad Wu

ANTENNA POLARITY & TEST DISTANCE: HORIZONTAL AT 3 M								
NO.	FREQ. (MHz)	EMISSION LEVEL (dBuV/m)	LIMIT (dBuV/m)	MARGIN (dB)	ANTENNA HEIGHT (m)	TABLE ANGLE (Degree)	RAW VALUE (dBuV)	CORRECTION FACTOR (dB/m)
1	#5460.00	47.19 PK	74.00	-26.81	1.02 H	172	8.20	38.99
2	#5460.00	36.45 AV	54.00	-17.55	1.02 H	172	-2.54	38.99
3	5470.00	51.11 PK	88.30	-37.19	1.02 H	172	12.10	39.01
4	5470.00	37.27 AV	68.30	-31.03	1.02 H	172	-1.74	39.01
5	*5500.00	96.66 PK			1.02 H	172	57.58	39.07
6	*5500.00	86.25 AV			1.02 H	172	47.18	39.07
7	#11000.00	58.02 PK	74.00	-15.98	1.05 H	251	8.13	49.89
8	#11000.00	45.33 AV	54.00	-8.67	1.05 H	251	-4.56	49.89

ANTENNA POLARITY & TEST DISTANCE: VERTICAL AT 3 M								
NO.	FREQ. (MHz)	EMISSION LEVEL (dBuV/m)	LIMIT (dBuV/m)	MARGIN (dB)	ANTENNA HEIGHT (m)	TABLE ANGLE (Degree)	RAW VALUE (dBuV)	CORRECTION FACTOR (dB/m)
1	#5460.00	53.31 PK	74.00	-20.69	1.22 V	168	14.32	38.99
2	#5460.00	38.57 AV	54.00	-15.43	1.22 V	168	-0.42	38.99
3	5470.00	57.40 PK	88.30	-30.90	1.22 V	168	18.39	39.01
4	5470.00	39.91 AV	68.30	-28.39	1.22 V	168	0.90	39.01
5	*5500.00	101.20 PK			1.22 V	168	62.13	39.07
6	*5500.00	90.62 AV			1.22 V	168	51.54	39.07
7	#11000.00	58.95 PK	74.00	-15.05	1.01 V	16	9.06	49.89
8	#11000.00	45.43 AV	54.00	-8.57	1.01 V	16	-4.46	49.89

- REMARKS:**
1. Emission level (dBuV/m) = Raw Value (dBuV) + Correction Factor (dB/m).
 2. Correction Factor (dB/m) = Antenna Factor (dB/m) + Cable Factor (dB).
 3. The other emission levels were very low against the limit.
 4. Margin value = Emission level – Limit value.
 5. “ * “: Fundamental frequency.
 6. “ # “: The radiated frequency falling in the restricted band.



EUT TEST CONDITION		MEASUREMENT DETAIL	
CHANNEL	Channel 6	FREQUENCY RANGE	1 ~ 40GHz
INPUT POWER (SYSTEM)	120Vac, 60 Hz	DETECTOR FUNCTION	Peak (PK) Average (AV)
ENVIRONMENTAL CONDITIONS	23deg. C, 70%RH 1002hPa	TESTED BY	Brad Wu

ANTENNA POLARITY & TEST DISTANCE: HORIZONTAL AT 3 M								
NO.	FREQ. (MHz)	EMISSION LEVEL (dBuV/m)	LIMIT (dBuV/m)	MARGIN (dB)	ANTENNA HEIGHT (m)	TABLE ANGLE (Degree)	RAW VALUE (dBuV)	CORRECTION FACTOR (dB/m)
1	*5600.00	99.58 PK			1.03 H	175	60.29	39.29
2	*5600.00	89.14 AV			1.03 H	175	49.85	39.29
3	#11200.00	58.23 PK	74.00	-15.77	1.08 H	235	8.45	49.78
4	#11200.00	45.56 AV	54.00	-8.44	1.08 H	235	-4.22	49.78
ANTENNA POLARITY & TEST DISTANCE: VERTICAL AT 3 M								
NO.	FREQ. (MHz)	EMISSION LEVEL (dBuV/m)	LIMIT (dBuV/m)	MARGIN (dB)	ANTENNA HEIGHT (m)	TABLE ANGLE (Degree)	RAW VALUE (dBuV)	CORRECTION FACTOR (dB/m)
1	*5600.00	104.33 PK			1.20 V	181	65.04	39.29
2	*5600.00	93.55 AV			1.20 V	181	54.26	39.29
3	#11200.00	59.23 PK	74.00	-14.77	1.06 V	259	9.45	49.78
4	#11200.00	45.81 AV	54.00	-8.19	1.06 V	259	-3.97	49.78

- REMARKS:**
1. Emission level (dBuV/m) = Raw Value (dBuV) + Correction Factor (dB/m).
 2. Correction Factor (dB/m) = Antenna Factor (dB/m) + Cable Factor (dB).
 3. The other emission levels were very low against the limit.
 4. Margin value = Emission level – Limit value.
 5. “ * “: Fundamental frequency.
 6. “ # “: The radiated frequency falling in the restricted band.



EUT TEST CONDITION		MEASUREMENT DETAIL	
CHANNEL	Channel 11	FREQUENCY RANGE	1 ~ 40GHz
INPUT POWER (SYSTEM)	120Vac, 60 Hz	DETECTOR FUNCTION	Peak (PK) Average (AV)
ENVIRONMENTAL CONDITIONS	23deg. C, 70%RH 1002hPa	TESTED BY	Brad Wu

ANTENNA POLARITY & TEST DISTANCE: HORIZONTAL AT 3 M								
NO.	FREQ. (MHz)	EMISSION LEVEL (dBuV/m)	LIMIT (dBuV/m)	MARGIN (dB)	ANTENNA HEIGHT (m)	TABLE ANGLE (Degree)	RAW VALUE (dBuV)	CORRECTION FACTOR (dB/m)
1	*5700.00	94.31 PK			1.05 H	178	54.75	39.56
2	*5700.00	83.94 AV			1.05 H	178	44.38	39.56
3	5725.00	50.96 PK	88.30	-37.34	1.05 H	178	11.35	39.61
4	5725.00	35.42 AV	68.30	-32.88	1.05 H	178	-4.19	39.61
5	#11400.00	59.23 PK	74.00	-14.77	1.01 H	213	9.37	49.86
6	#11400.00	45.69 AV	54.00	-8.31	1.01 H	213	-4.17	49.86
ANTENNA POLARITY & TEST DISTANCE: VERTICAL AT 3 M								
NO.	FREQ. (MHz)	EMISSION LEVEL (dBuV/m)	LIMIT (dBuV/m)	MARGIN (dB)	ANTENNA HEIGHT (m)	TABLE ANGLE (Degree)	RAW VALUE (dBuV)	CORRECTION FACTOR (dB/m)
1	*5700.00	98.96 PK			1.08 V	172	59.40	39.56
2	*5700.00	88.57 AV			1.08 V	172	49.01	39.56
3	5725.00	53.85 PK	88.30	-34.45	1.08 V	172	14.24	39.61
4	5725.00	38.33 AV	68.30	-29.97	1.08 V	172	-1.28	39.61
5	#11400.00	59.14 PK	74.00	-14.86	1.02 V	53	9.28	49.86
6	#11400.00	45.36 AV	54.00	-8.64	1.02 V	53	-4.50	49.86

- REMARKS:**
1. Emission level (dBuV/m) = Raw Value (dBuV) + Correction Factor (dB/m).
 2. Correction Factor (dB/m) = Antenna Factor (dB/m) + Cable Factor (dB).
 3. The other emission levels were very low against the limit.
 4. Margin value = Emission level – Limit value.
 5. “ * “: Fundamental frequency.
 6. “ # “: The radiated frequency falling in the restricted band.



**BELOW 1GHz WORST-CASE DATA:
FOR 5150-5350MHz BAND: 802.11a OFDM MODULATION:**

EUT TEST CONDITION		MEASUREMENT DETAIL	
CHANNEL	Channel 8	FREQUENCY RANGE	Below 1000MHz
INPUT POWER (SYSTEM)	120Vac, 60 Hz	DETECTOR FUNCTION	Quasi-Peak
ENVIRONMENTAL CONDITIONS	22deg. C, 69%RH 1002hPa	TESTED BY	Lori Chiu

ANTENNA POLARITY & TEST DISTANCE: HORIZONTAL AT 3 M								
NO.	FREQ. (MHz)	EMISSION LEVEL (dBuV/m)	LIMIT (dBuV/m)	MARGIN (dB)	ANTENNA HEIGHT (m)	TABLE ANGLE (Degree)	RAW VALUE (dBuV)	CORRECTION FACTOR (dB/m)
1	115.45	26.78 QP	43.50	-16.72	1.50 H	283	15.59	11.20
2	144.61	23.61 QP	43.50	-19.89	1.00 H	262	10.49	13.12
3	195.16	28.74 QP	43.50	-14.76	1.50 H	235	17.78	10.96
4	239.88	27.91 QP	46.00	-18.09	1.00 H	169	15.59	12.33
5	543.19	26.10 QP	46.00	-19.90	1.00 H	181	5.95	20.15
6	953.44	28.99 QP	46.00	-17.01	1.75 H	175	2.64	26.35
ANTENNA POLARITY & TEST DISTANCE: VERTICAL AT 3 M								
NO.	FREQ. (MHz)	EMISSION LEVEL (dBuV/m)	LIMIT (dBuV/m)	MARGIN (dB)	ANTENNA HEIGHT (m)	TABLE ANGLE (Degree)	RAW VALUE (dBuV)	CORRECTION FACTOR (dB/m)
1	53.23	25.00 QP	40.00	-15.00	1.75 V	148	11.37	13.64
2	113.50	25.26 QP	43.50	-18.24	1.00 V	151	14.30	10.96
3	177.67	24.99 QP	43.50	-18.51	1.00 V	121	12.57	12.42
4	197.11	25.56 QP	43.50	-17.94	1.00 V	298	14.76	10.79
5	337.10	26.41 QP	46.00	-19.59	1.75 V	22	11.92	14.49
6	442.09	25.38 QP	46.00	-20.62	1.00 V	226	8.10	17.28
7	494.58	25.27 QP	46.00	-20.73	1.00 V	166	6.33	18.93
8	545.14	25.96 QP	46.00	-20.04	1.00 V	151	5.76	20.20
9	945.66	28.36 QP	46.00	-17.64	1.00 V	349	2.07	26.29

- REMARKS:**
1. Emission level (dBuV/m) = Raw Value (dBuV) + Correction Factor (dB/m).
 2. Correction Factor (dB/m) = Antenna Factor (dB/m) + Cable Factor (dB).
 3. The other emission levels were very low against the limit.
 4. Margin value = Emission level – Limit value.



FOR 5470-5725MHz BAND: 802.11a OFDM MODULATION:

EUT TEST CONDITION		MEASUREMENT DETAIL	
CHANNEL	Channel 6	FREQUENCY RANGE	Below 1000MHz
INPUT POWER (SYSTEM)	120Vac, 60 Hz	DETECTOR FUNCTION	Quasi-Peak
ENVIRONMENTAL CONDITIONS	22deg. C, 69%RH 1002hPa	TESTED BY	Lori Chiu

ANTENNA POLARITY & TEST DISTANCE: HORIZONTAL AT 3 M								
NO.	FREQ. (MHz)	EMISSION LEVEL (dBuV/m)	LIMIT (dBuV/m)	MARGIN (dB)	ANTENNA HEIGHT (m)	TABLE ANGLE (Degree)	RAW VALUE (dBuV)	CORRECTION FACTOR (dB/m)
1	113.50	25.58 QP	43.50	-17.92	1.50 H	100	14.62	10.96
2	144.61	23.65 QP	43.50	-19.85	1.00 H	109	10.53	13.12
3	197.11	28.91 QP	43.50	-14.59	1.00 H	145	18.12	10.79
4	235.99	28.48 QP	46.00	-17.52	1.00 H	157	16.32	12.15
5	543.19	25.91 QP	46.00	-20.09	1.00 H	142	5.75	20.15
6	945.66	28.74 QP	46.00	-17.26	2.00 H	208	2.46	26.29
ANTENNA POLARITY & TEST DISTANCE: VERTICAL AT 3 M								
NO.	FREQ. (MHz)	EMISSION LEVEL (dBuV/m)	LIMIT (dBuV/m)	MARGIN (dB)	ANTENNA HEIGHT (m)	TABLE ANGLE (Degree)	RAW VALUE (dBuV)	CORRECTION FACTOR (dB/m)
1	55.18	25.88 QP	40.00	-14.12	1.50 V	85	12.33	13.55
2	115.45	25.92 QP	43.50	-17.58	1.00 V	166	14.73	11.20
3	193.22	24.98 QP	43.50	-18.52	1.00 V	127	13.86	11.13
4	208.77	25.94 QP	43.50	-17.56	1.00 V	97	15.01	10.94
5	337.10	26.15 QP	46.00	-19.85	2.00 V	31	11.66	14.49
6	945.66	30.19 QP	46.00	-15.81	1.00 V	268	3.90	26.29

- REMARKS:**
1. Emission level (dBuV/m) = Raw Value (dBuV) + Correction Factor (dB/m).
 2. Correction Factor (dB/m) = Antenna Factor (dB/m) + Cable Factor (dB).
 3. The other emission levels were very low against the limit.
 4. Margin value = Emission level – Limit value.

4.2 CONDUCTED EMISSION MEASUREMENT

4.2.1 LIMITS OF CONDUCTED EMISSION MEASUREMENT

FREQUENCY OF EMISSION (MHz)	CONDUCTED LIMIT (dB μ V)	
	Quasi-peak	Average
0.15 ~ 0.5	66 to 56	56 to 46
0.5 ~ 5	56	46
5 ~ 30	60	50

- NOTE:**
1. The lower limit shall apply at the transition frequencies.
 2. The limit decreases in line with the logarithm of the frequency in the range of 0.15 to 0.50MHz.
 3. All emanations from a class A/B digital device or system, including any network of conductors and apparatus connected thereto, shall not exceed the level of field strengths specified above.

4.2.2 TEST INSTRUMENTS

DESCRIPTION & MANUFACTURER	MODEL NO.	SERIAL NO.	CALIBRATED UNTIL
Test Receiver ROHDE & SCHWARZ	ESCS30	100288	Sep. 21, 2008
RF signal cable Woken	5D-FB	Cable-HYCO3-01	Jan. 06, 2009
LISN ROHDE & SCHWARZ	ESH2-Z5	100100	Jan. 09, 2009
LISN SCHWARZBECK	NNBL 8226-2	8226-142	May 07, 2008
Software ADT	ADT_Cond_V3	NA	NA

- NOTE:**
1. The calibration interval of the above test instruments is 12 months and the calibrations are traceable to NML/ROC and NIST/USA.
 2. The test was performed in HwaYa Shielded Room 2.
 3. The VCCI Site Registration No. is C-2047.

4.2.3 TEST PROCEDURES

- a. The EUT was placed 0.4 meters from the conducting wall of the shielded room with EUT being connected to the power mains through a line impedance stabilization network (LISN). Other support units were connected to the power mains through another LISN. The two LISNs provide 50 ohm/ 50uH of coupling impedance for the measuring instrument.
- b. Both lines of the power mains connected to the EUT were checked for maximum conducted interference.
- c. The frequency range from 150kHz to 30MHz was searched. Emission levels under (Limit - 20dB) was not recorded.

4.2.4 DEVIATION FROM TEST STANDARD

No deviation

4.2.5 TEST SETUP

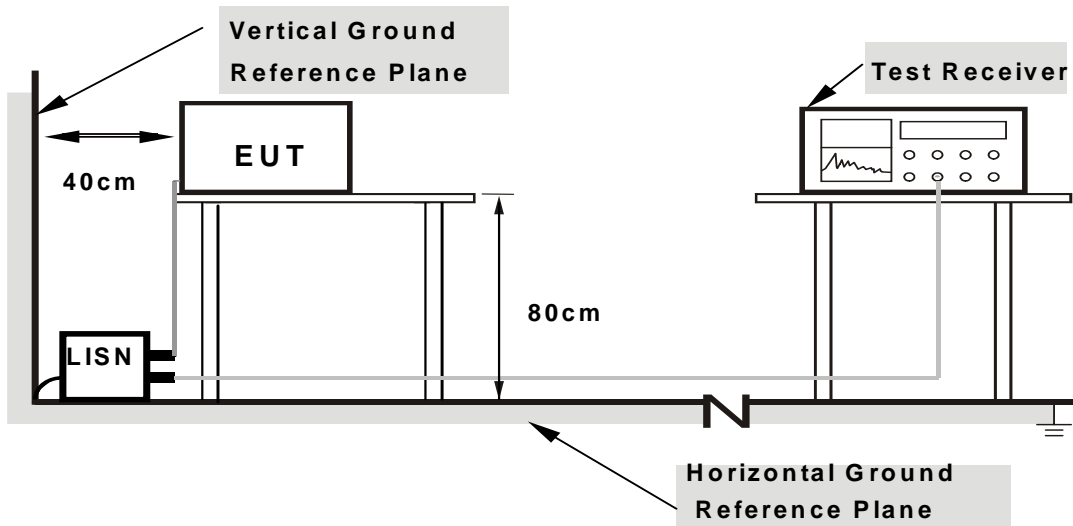

- Note:**
- 1.Support units were connected to second LISN.
 - 2.Both of LISNs (AMN) are 80 cm from EUT and at least 80 from other units and other metal planes

For the actual test configuration, please refer to the related item – Photographs of the Test Configuration.

4.2.6 EUT OPERATING CONDITIONS

Same as 4.1.6

4.2.7 TEST RESULTS

CONDUCTED WORST-CASE DATA:

FOR 5150-5350MHz BAND: 802.11a OFDM MODULATION:

EUT TEST CONDITION		MEASUREMENT DETAIL	
CHANNEL	Channel 8	PHASE	Line 1
MODULATION TYPE	BPSK	INPUT POWER (SYSTEM)	120Vac, 60Hz
ENVIRONMENTAL CONDITIONS	20deg. C, 60%RH, 991hPa	6dB BANDWIDTH	9kHz
TESTED BY	Match Tsui		

No	Freq. [MHz]	Corr. Factor (dB)	Reading Value		Emission Level		Limit		Margin	
			[dB (uV)]		[dB (uV)]		[dB (uV)]		(dB)	
			Q.P.	AV.	Q.P.	AV.	Q.P.	AV.	Q.P.	AV.
1	0.173	0.10	44.37	-	44.47	-	64.80	54.80	-20.33	-
2	0.232	0.10	35.44	-	35.54	-	62.38	52.38	-26.84	-
3	0.517	0.10	16.52	-	16.62	-	56.00	46.00	-39.38	-
4	3.594	0.27	25.33	-	25.60	-	56.00	46.00	-30.40	-
5	9.297	0.32	30.75	-	31.07	-	60.00	50.00	-28.93	-
6	16.020	0.50	37.36	-	37.86	-	60.00	50.00	-22.14	-

- REMARKS:**
1. Q.P. and AV. are abbreviations of quasi-peak and average individually.
 2. "-": The Quasi-peak reading value also meets average limit and measurement with the average detector is unnecessary.
 3. The emission levels of other frequencies were very low against the limit.
 4. Margin value = Emission level - Limit value
 5. Correction factor = Insertion loss + Cable loss
 6. Emission Level = Correction Factor + Reading Value.

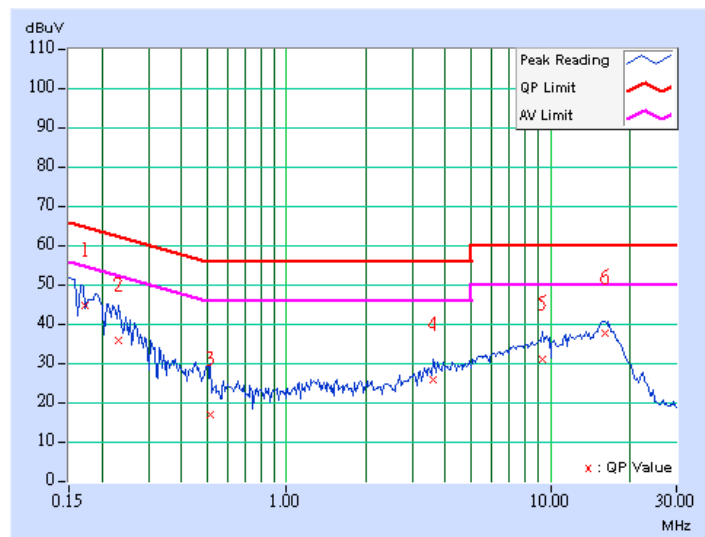

EUT TEST CONDITION		MEASUREMENT DETAIL	
CHANNEL	Channel 8	PHASE	Line 2
MODULATION TYPE	BPSK	INPUT POWER (SYSTEM)	120Vac, 60Hz
ENVIRONMENTAL CONDITIONS	20deg. C, 60%RH, 991hPa	6dB BANDWIDTH	9kHz
TESTED BY	Match Tsui		

No	Freq. [MHz]	Corr. Factor (dB)	Reading Value		Emission Level		Limit		Margin	
			[dB (uV)]		[dB (uV)]		[dB (uV)]		(dB)	
			Q.P.	AV.	Q.P.	AV.	Q.P.	AV.	Q.P.	AV.
1	0.171	0.10	45.12	-	45.22	-	64.93	54.93	-19.71	-
2	0.232	0.10	28.86	-	28.96	-	62.38	52.38	-33.42	-
3	0.494	0.12	29.29	-	29.41	-	56.10	46.10	-26.70	-
4	3.934	0.28	25.94	-	26.22	-	56.00	46.00	-29.78	-
5	11.805	0.45	32.54	-	32.99	-	60.00	50.00	-27.01	-
6	16.332	0.50	37.62	-	38.12	-	60.00	50.00	-21.88	-

- REMARKS:**
1. Q.P. and AV. are abbreviations of quasi-peak and average individually.
 2. "-": The Quasi-peak reading value also meets average limit and measurement with the average detector is unnecessary.
 3. The emission levels of other frequencies were very low against the limit.
 4. Margin value = Emission level - Limit value
 5. Correction factor = Insertion loss + Cable loss
 6. Emission Level = Correction Factor + Reading Value.

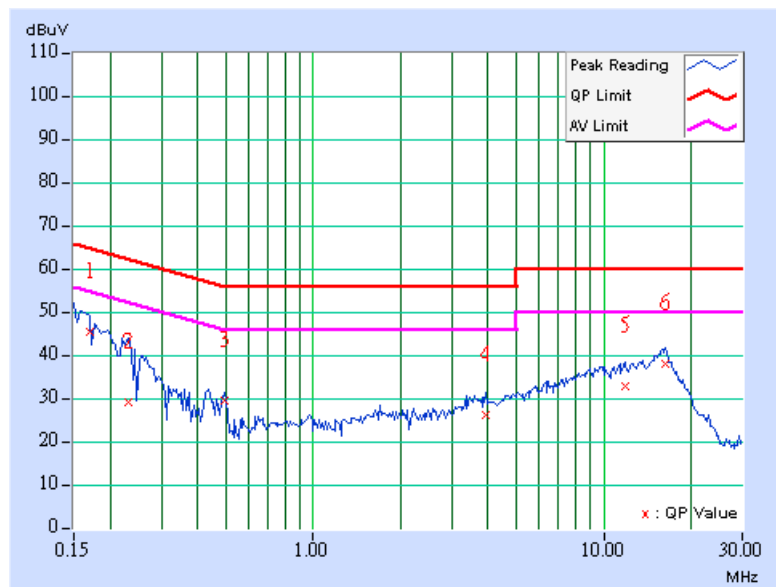

FOR 5470-5725MHz BAND: 802.11a OFDM MODULATION:

EUT TEST CONDITION		MEASUREMENT DETAIL	
CHANNEL	Channel 6	PHASE	Line 1
MODULATION TYPE	BPSK	INPUT POWER (SYSTEM)	120Vac, 60Hz
ENVIRONMENTAL CONDITIONS	20deg. C, 60%RH, 991hPa	6dB BANDWIDTH	9kHz
TESTED BY	Match Tsui		

No	Freq. [MHz]	Corr. Factor (dB)	Reading Value		Emission Level		Limit		Margin	
			[dB (uV)]		[dB (uV)]		[dB (uV)]		(dB)	
			Q.P.	AV.	Q.P.	AV.	Q.P.	AV.	Q.P.	AV.
1	0.181	0.10	38.26	-	38.36	-	64.43	54.43	-26.07	-
2	0.216	0.10	39.74	-	39.84	-	62.96	52.96	-23.12	-
3	0.505	0.10	27.56	-	27.66	-	56.00	46.00	-28.34	-
4	3.594	0.27	24.03	-	24.30	-	56.00	46.00	-31.70	-
5	9.285	0.32	31.42	-	31.74	-	60.00	50.00	-28.26	-
6	15.996	0.50	36.30	-	36.80	-	60.00	50.00	-23.20	-

- REMARKS:**
1. Q.P. and AV. are abbreviations of quasi-peak and average individually.
 2. "-": The Quasi-peak reading value also meets average limit and measurement with the average detector is unnecessary.
 3. The emission levels of other frequencies were very low against the limit.
 4. Margin value = Emission level - Limit value
 5. Correction factor = Insertion loss + Cable loss
 6. Emission Level = Correction Factor + Reading Value.

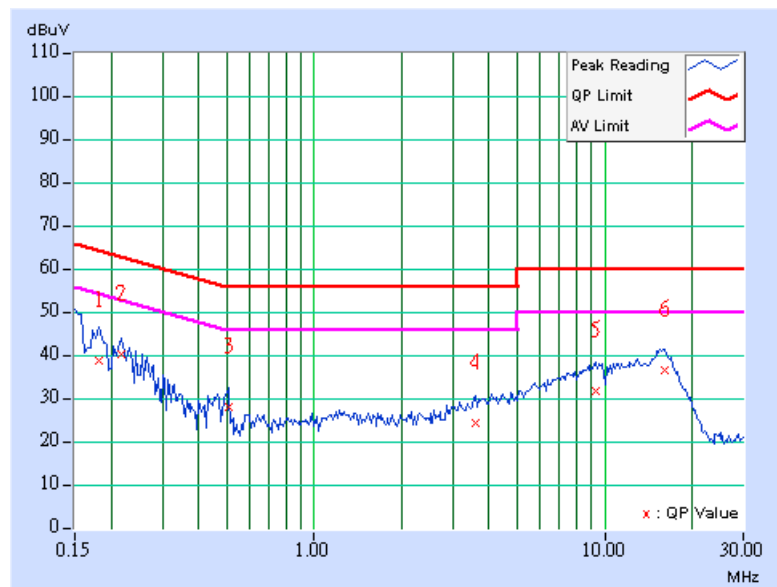

EUT TEST CONDITION		MEASUREMENT DETAIL	
CHANNEL	Channel 6	PHASE	Line 2
MODULATION TYPE	BPSK	INPUT POWER (SYSTEM)	120Vac, 60Hz
ENVIRONMENTAL CONDITIONS	20deg. C, 60%RH, 991hPa	6dB BANDWIDTH	9kHz
TESTED BY	Match Tsui		

No	Freq. [MHz]	Corr. Factor (dB)	Reading Value		Emission Level		Limit		Margin	
			[dB (uV)]		[dB (uV)]		[dB (uV)]		(dB)	
			Q.P.	AV.	Q.P.	AV.	Q.P.	AV.	Q.P.	AV.
1	0.166	0.10	37.37	-	37.47	-	65.18	55.18	-27.71	-
2	0.216	0.10	33.40	-	33.50	-	62.96	52.96	-29.46	-
3	0.486	0.12	30.37	-	30.49	-	56.24	46.24	-25.75	-
4	3.934	0.28	27.30	-	27.58	-	56.00	46.00	-28.42	-
5	8.598	0.39	31.11	-	31.50	-	60.00	50.00	-28.50	-
6	16.293	0.50	36.70	-	37.20	-	60.00	50.00	-22.80	-

- REMARKS:**
1. Q.P. and AV. are abbreviations of quasi-peak and average individually.
 2. "-": The Quasi-peak reading value also meets average limit and measurement with the average detector is unnecessary.
 3. The emission levels of other frequencies were very low against the limit.
 4. Margin value = Emission level - Limit value
 5. Correction factor = Insertion loss + Cable loss
 6. Emission Level = Correction Factor + Reading Value.

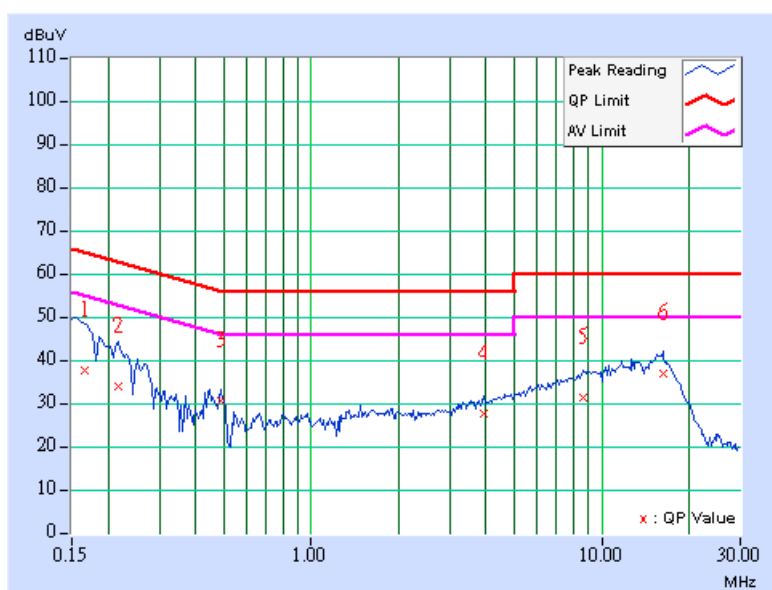



4.3 PEAK TRANSMIT POWER MEASUREMENT

4.3.1 LIMITS OF PEAK TRANSMIT POWER MEASUREMENT

FREQUENCY BAND	LIMIT
5.150 ~ 5.250GHz	The lesser of 50mW (17dBm) or 4dBm + 10logB
5.250 ~ 5.350GHz	The lesser of 250mW (24dBm) or 11dBm + 10logB
5.470 ~ 5.725GHz	The lesser of 250mW (24dBm) or 11dBm + 10logB

NOTE: Where B is the 26dB emission bandwidth in MHz.

4.3.2 TEST INSTRUMENTS

DESCRIPTION & MANUFACTURER	MODEL NO.	SERIAL NO.	CALIBRATED UNTIL
R&S SPECTRUM ANALYZER	FSP40	100040	Jun. 28, 2008

NOTE: The calibration interval of the above test instruments is 12 months and the calibrations are traceable to NML/ROC and NIST/USA.

4.3.3 TEST PROCEDURE

1. The transmitter output was connected to the spectrum analyzer.
2. Set span to encompass the entire emission bandwidth of the signal.
3. Set RBW to 1MHz, VBW to 3MHz.
4. Using the spectrum analyzer's channel power measurement function to measure the output power.

NOTE: The test is performed in accordance with FCC Public Notice: APPENDIX A Guidelines for Assessing Unlicensed National Information Infrastructure (U-NII) Devices – Part 15, Subpart E, August 2002.

The transmitter output operates continuously therefore Method # 1 is used.

4.3.4 DEVIATION FROM TEST STANDARD

No deviation

4.3.5 TEST SETUP

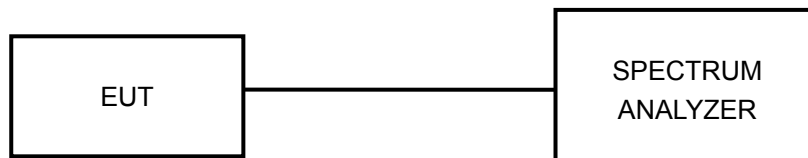

4.3.6 EUT OPERATING CONDITIONS

The software provided by client to enable the EUT under transmission condition continuously at specific channel frequencies individually.



4.3.7 TEST RESULTS

**PEAK POWER OUTPUT:
FOR 5150-5350MHz BAND: 802.11a OFDM MODULATION:**

MODULATION TYPE	BPSK	ENVIRONMENTAL CONDITIONS	25deg.C, 65%RH, 991hPa
INPUT POWER (SYSTEM)	120Vac, 60Hz	TESTED BY	Brad Wu

CHANNEL	CHANNEL FREQUENCY (MHz)	PEAK POWER OUTPUT (mW)	PEAK POWER OUTPUT (dBm)	PEAK POWER LIMIT (dBm)	PASS / FAIL
1	5180	12.79	11.07	17.00	PASS
2	5200	12.94	11.12	17.00	PASS
4	5240	12.71	11.04	17.00	PASS
5	5260	13.18	11.20	24.00	PASS
7	5300	15.24	11.83	24.00	PASS
8	5320	16.75	12.24	24.00	PASS

CH 1

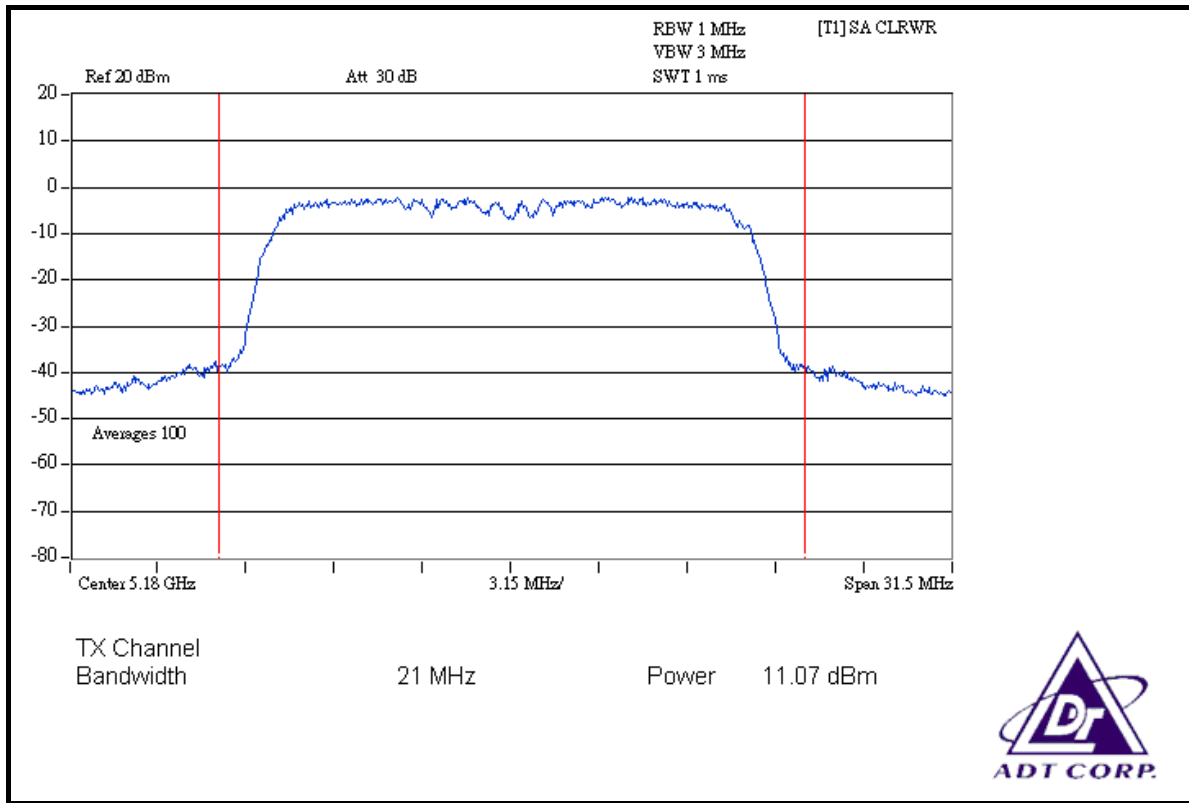

CH 2

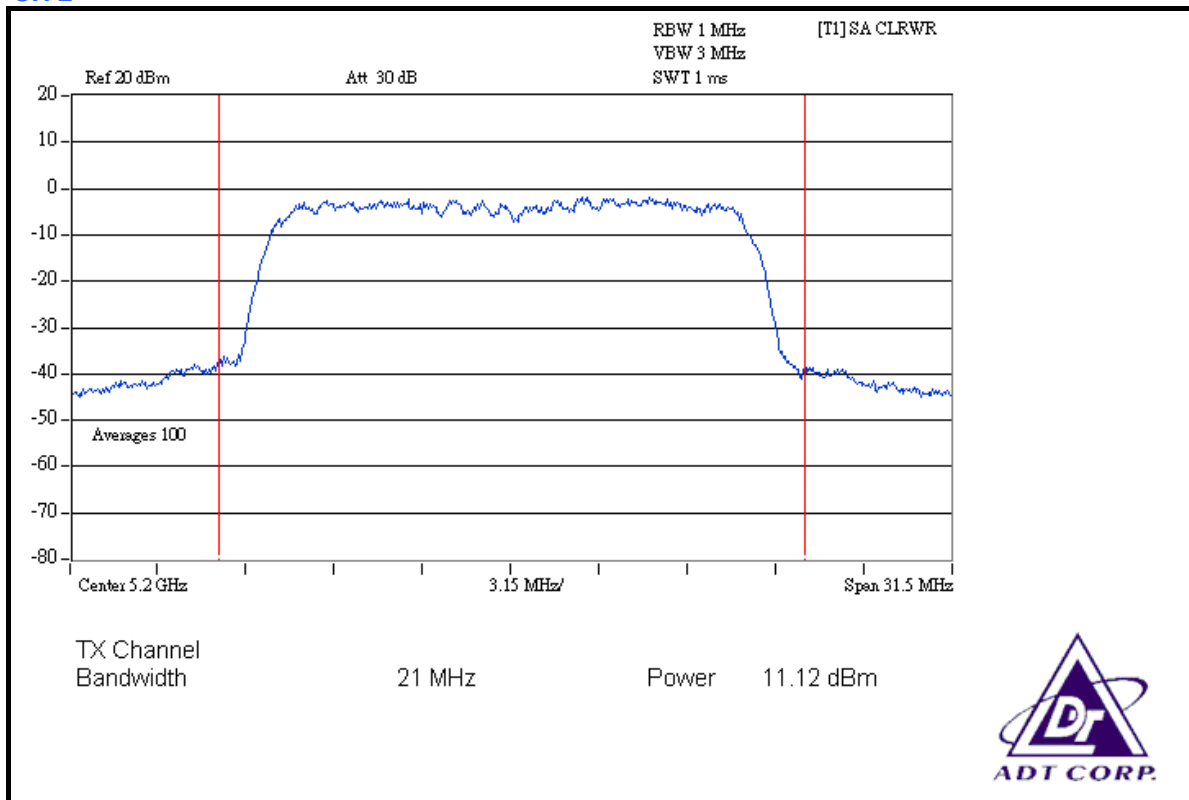

CH 4

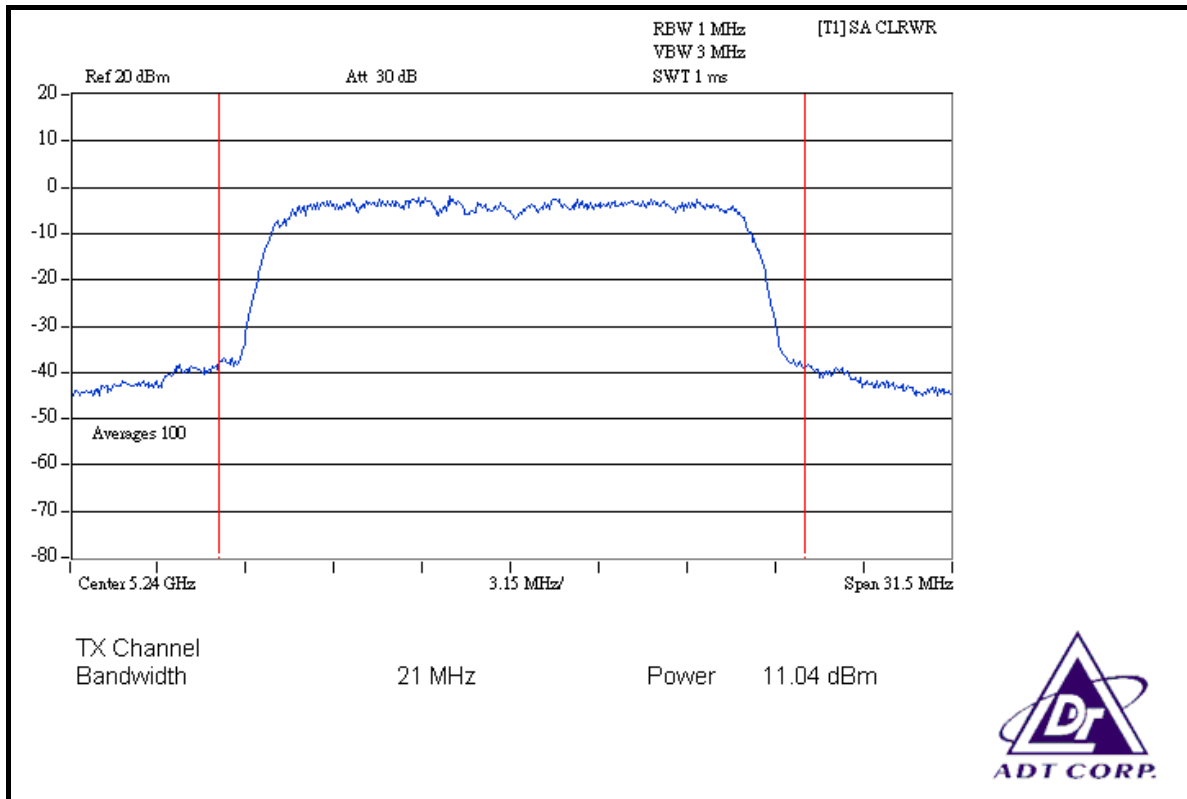

CH 5

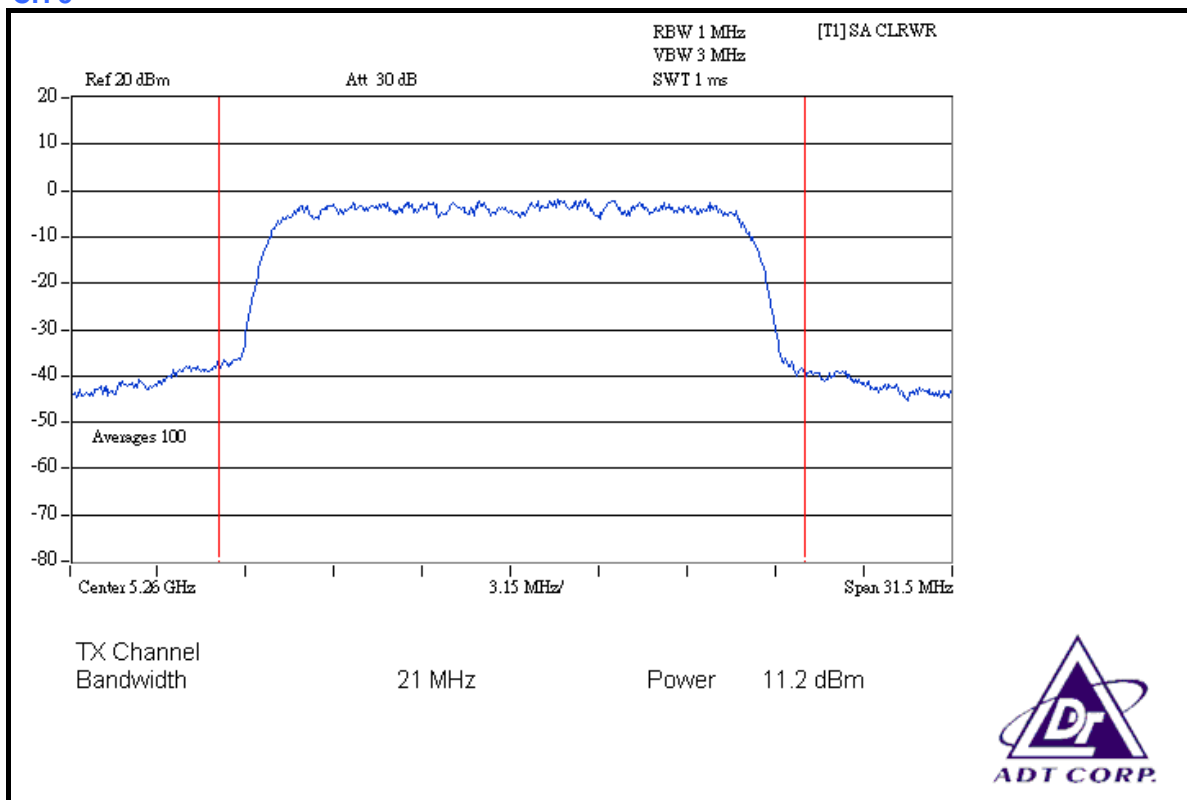

CH 7



CH 8

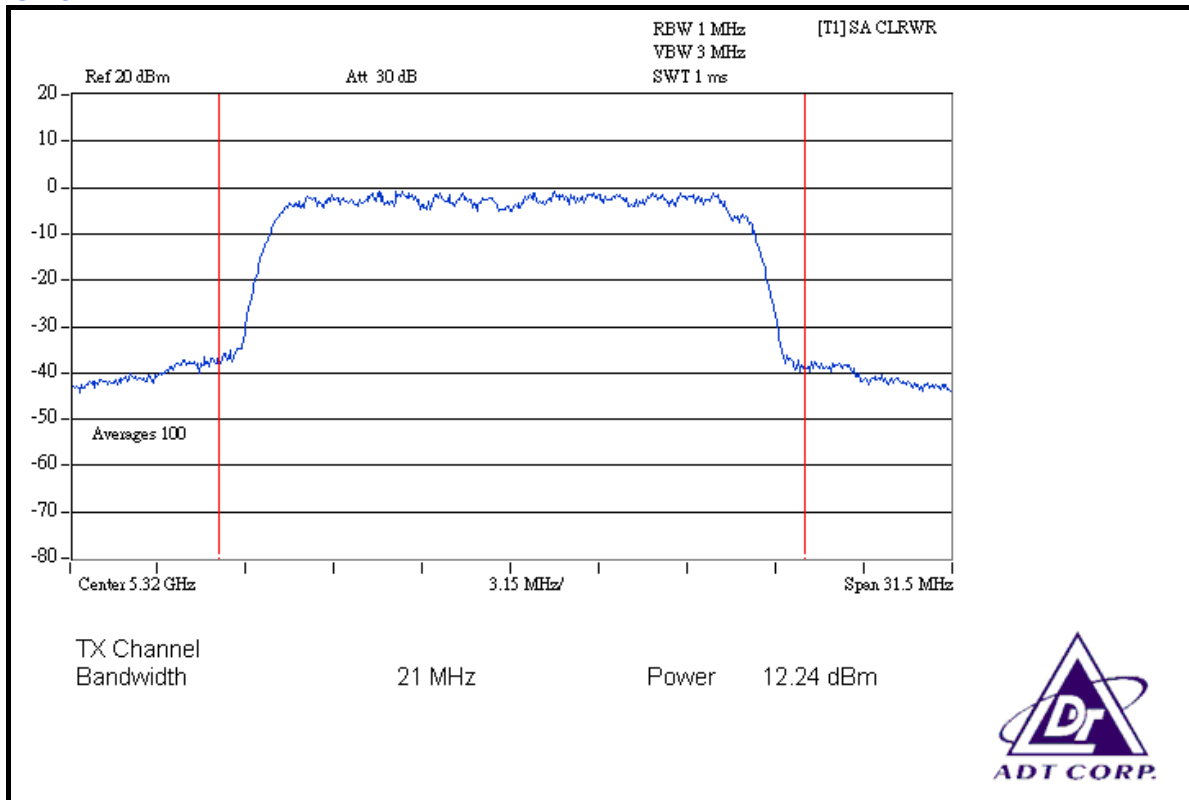



FOR 5470-5725MHz BAND: 802.11a OFDM MODULATION:

MODULATION TYPE	BPSK	ENVIRONMENTAL CONDITIONS	25deg.C, 67%RH, 991hPa
INPUT POWER (SYSTEM)	120Vac, 60Hz	TESTED BY	Brad Wu

CHANNEL	CHANNEL FREQUENCY (MHz)	PEAK POWER OUTPUT (mW)	PEAK POWER OUTPUT (dBm)	PEAK POWER LIMIT (dBm)	PASS / FAIL
1	5500	18.37	12.64	24.00	PASS
6	5600	26.79	14.28	24.00	PASS
11	5700	8.49	9.29	24.00	PASS

CH 1

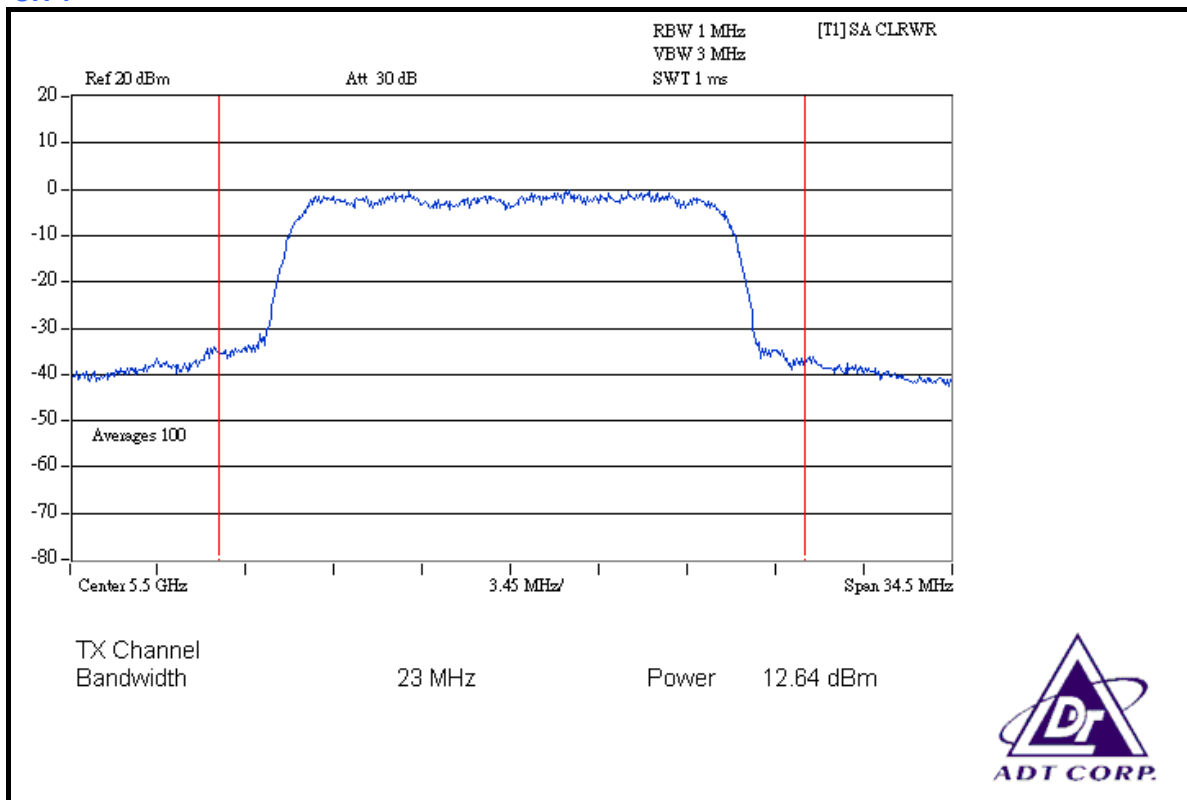

CH 6

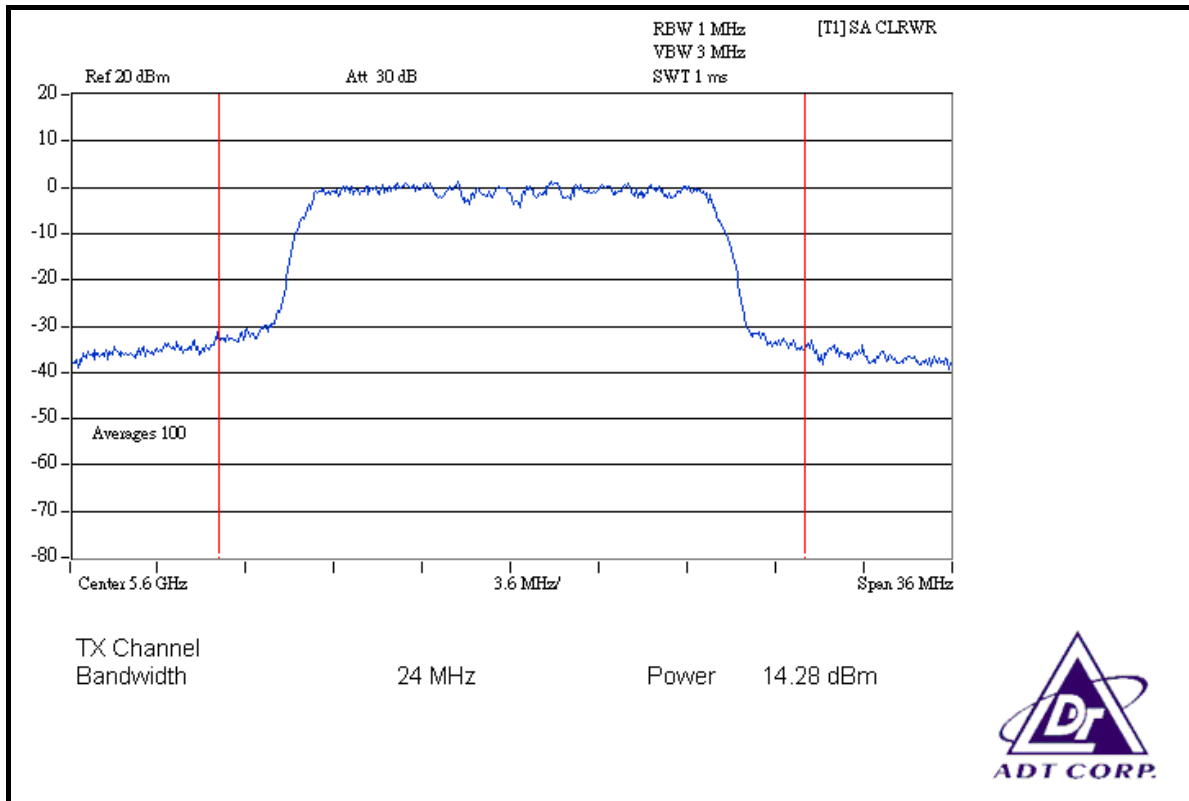

CH 11

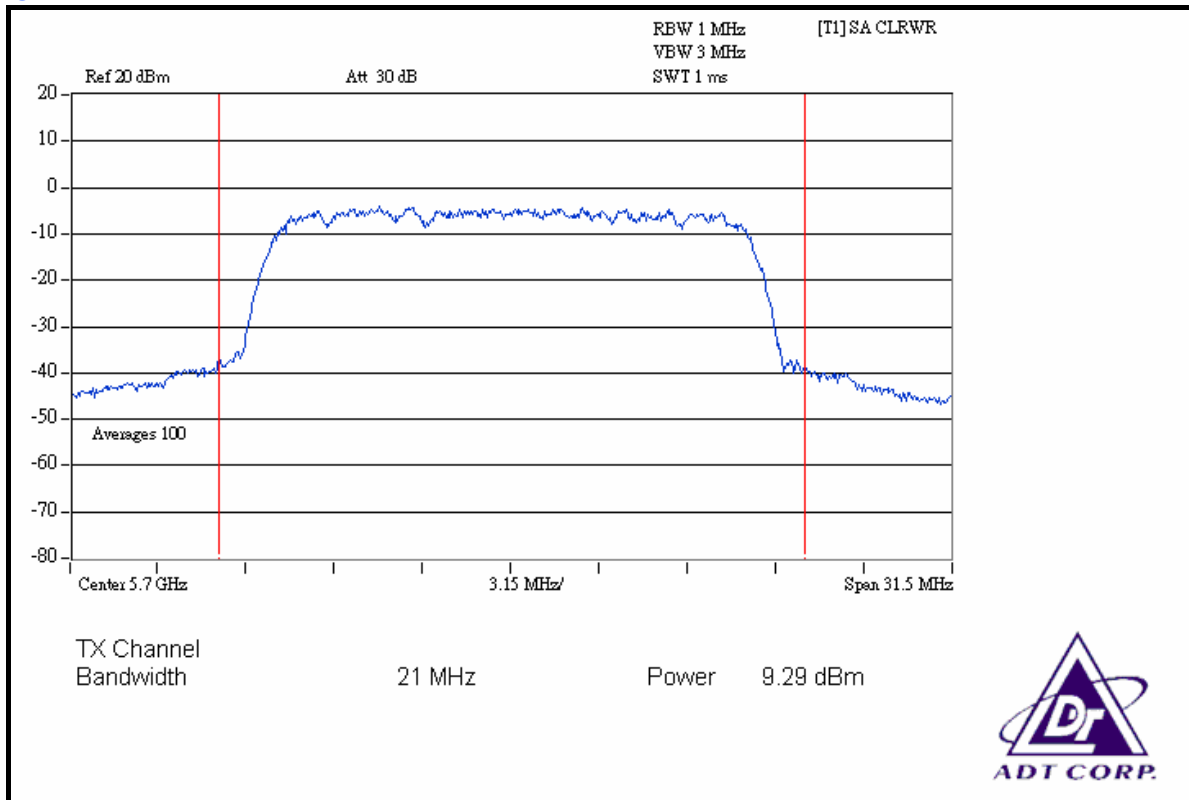



**26dB OCCUPIED BANDWIDTH:
FOR 5150-5350MHz BAND: 802.11a OFDM MODULATION:**

MODULATION TYPE	BPSK	ENVIRONMENTAL CONDITIONS	26deg.C, 67%RH, 991hPa
INPUT POWER (SYSTEM)	120Vac, 60Hz	TESTED BY	Brad Wu

CHANNEL	CHANNEL FREQUENCY (MHz)	26dBc OCCUPIED BANDWIDTH (MHz)	PASS / FAIL
1	5180	20.64	PASS
2	5200	20.24	PASS
4	5240	20.76	PASS
5	5260	20.56	PASS
7	5300	20.56	PASS
8	5320	20.63	PASS

CH 1

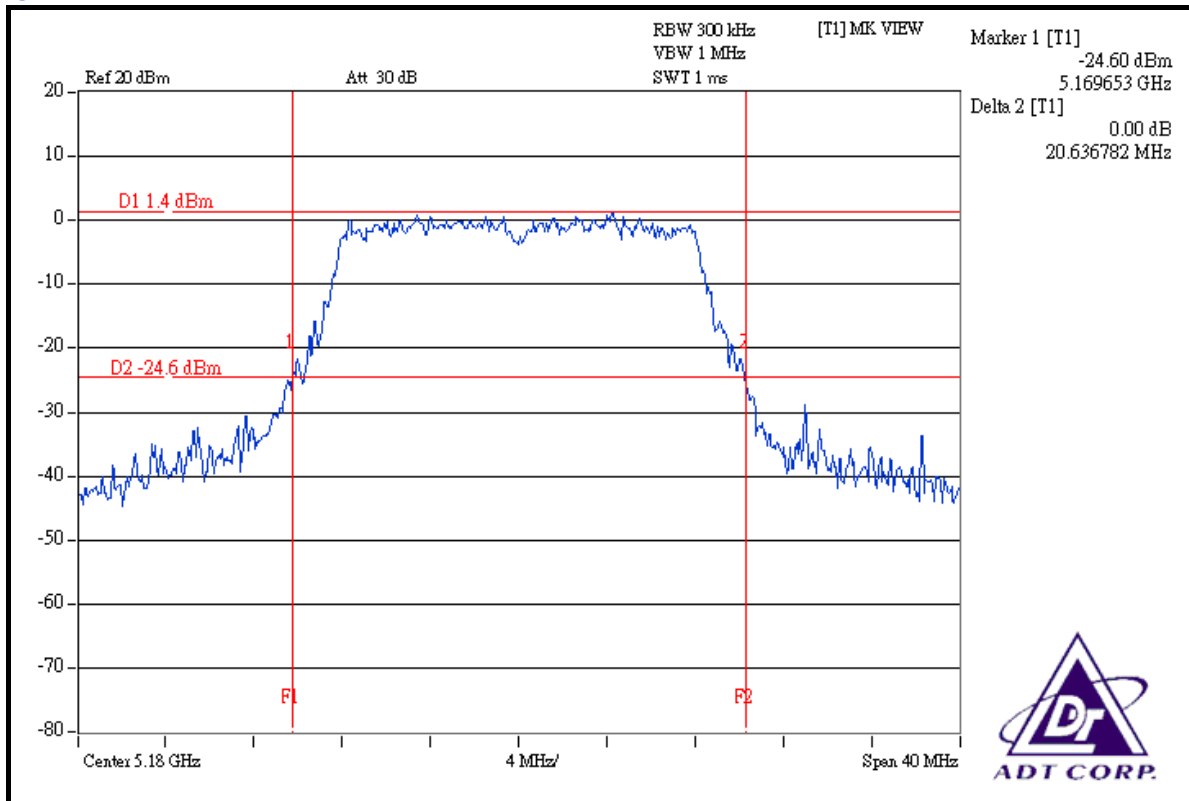

CH 2

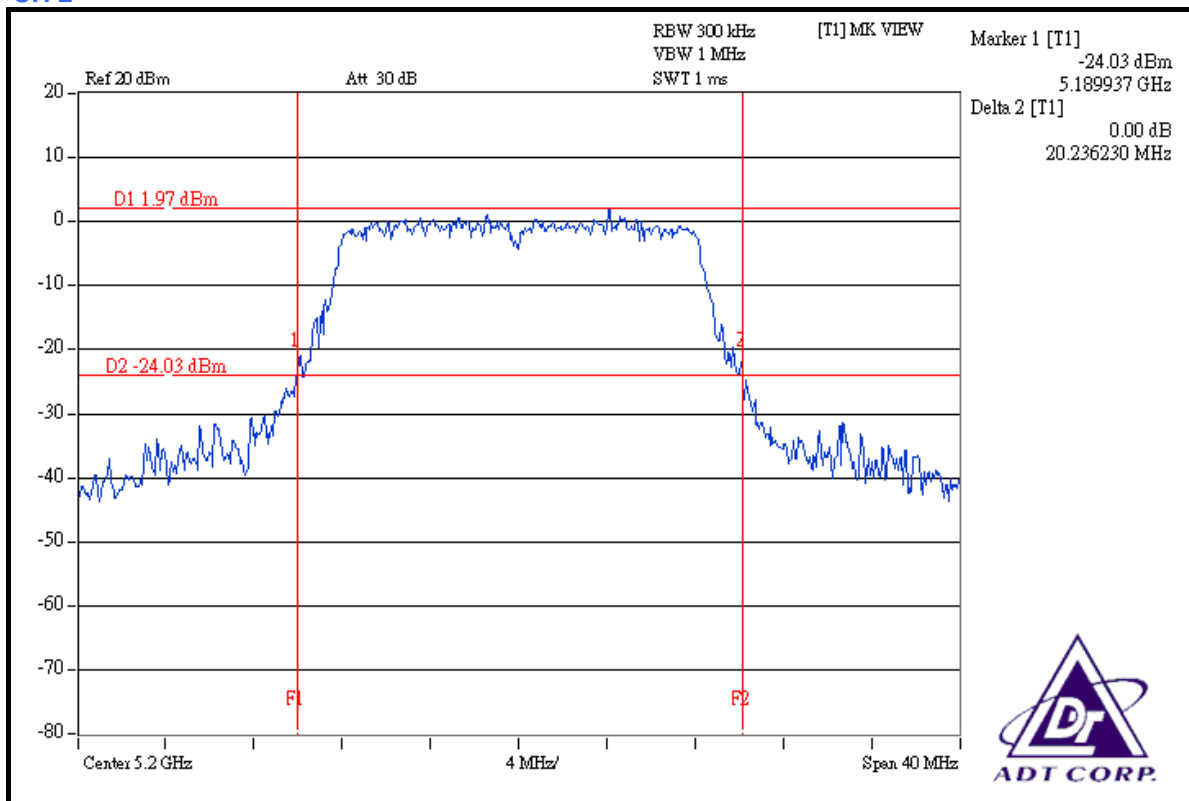

CH 4

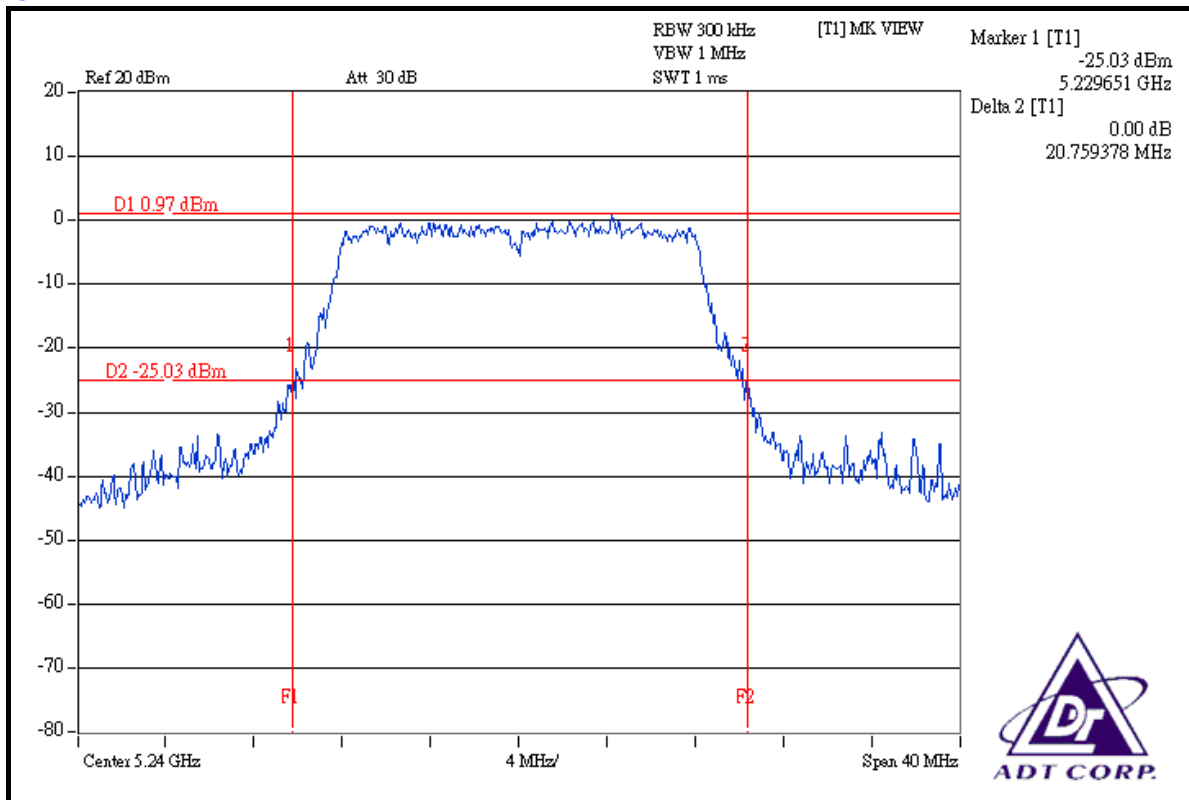

CH 5

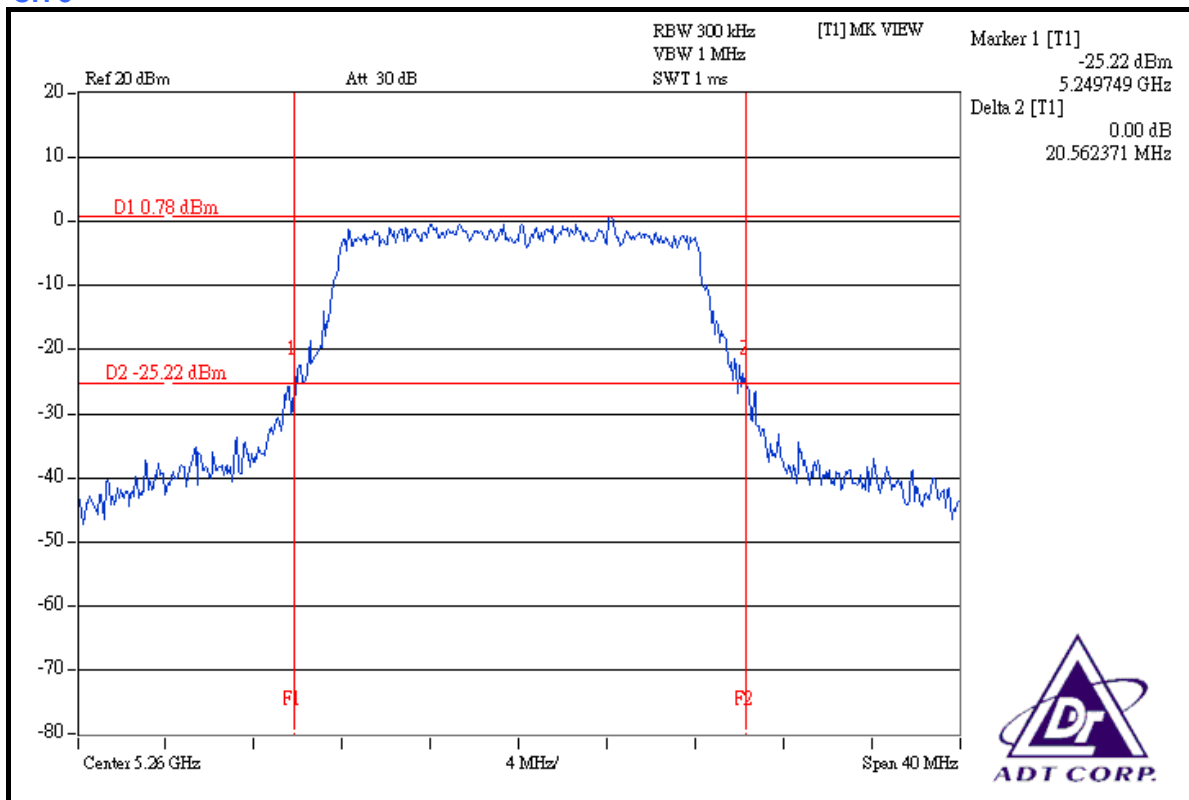

CH 7

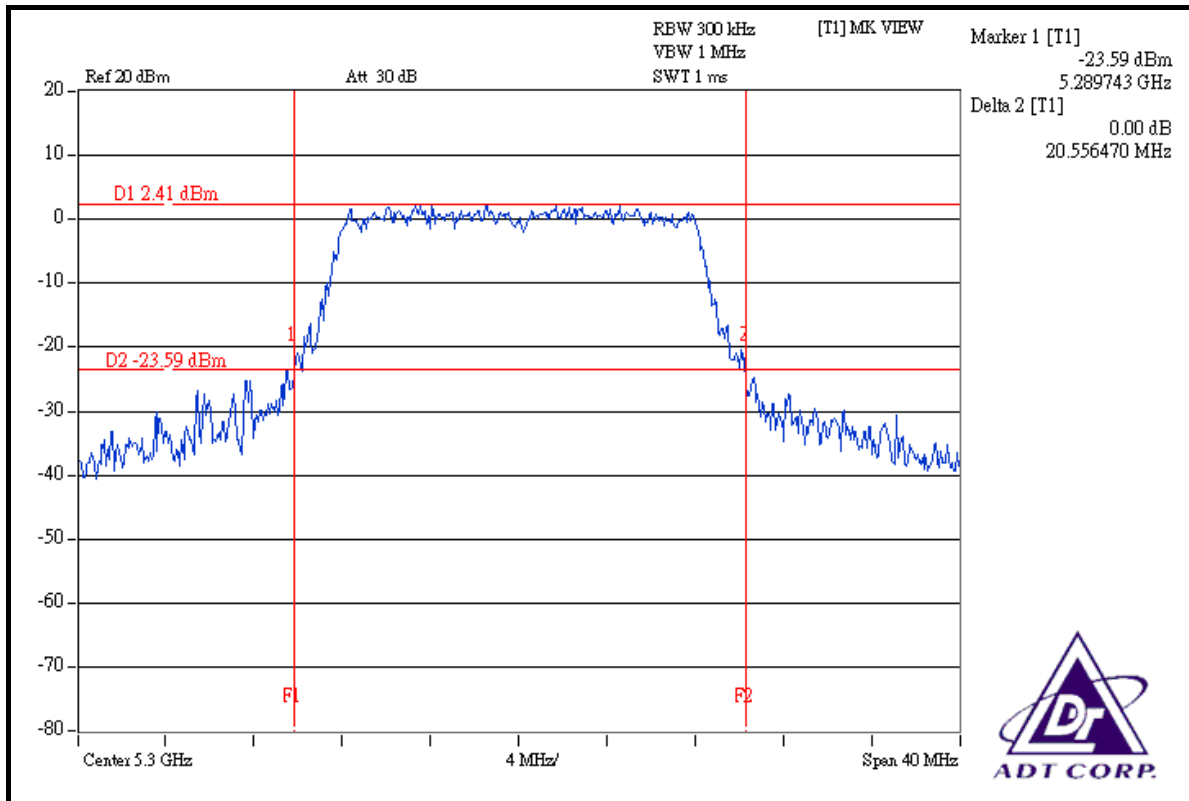

CH 8

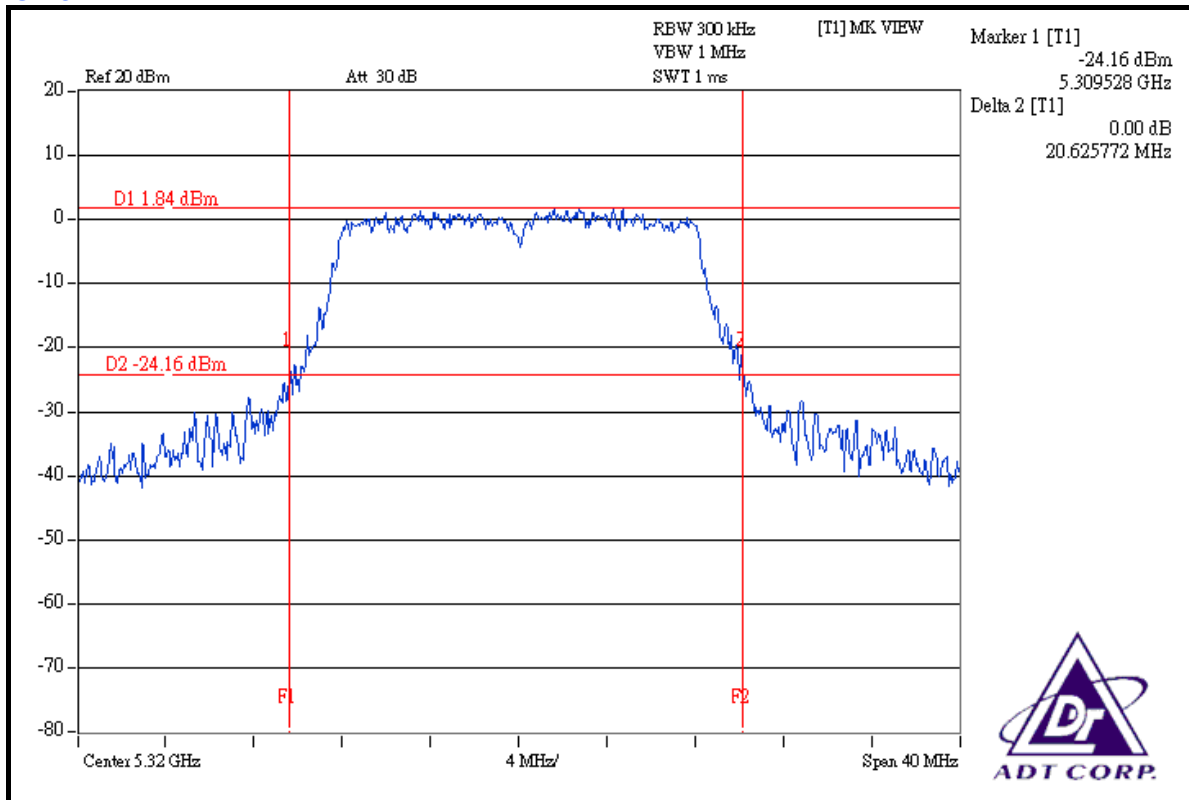



FOR 5470-5725MHz BAND: 802.11a OFDM MODULATION:

MODULATION TYPE	BPSK	ENVIRONMENTAL CONDITIONS	26deg.C, 67%RH, 991hPa
INPUT POWER (SYSTEM)	120Vac, 60Hz	TESTED BY	Brad Wu

CHANNEL	CHANNEL FREQUENCY (MHz)	26dBc OCCUPIED BANDWIDTH (MHz)	PASS / FAIL
1	5500	22.46	PASS
6	5600	23.47	PASS
11	5700	20.51	PASS

CH 1

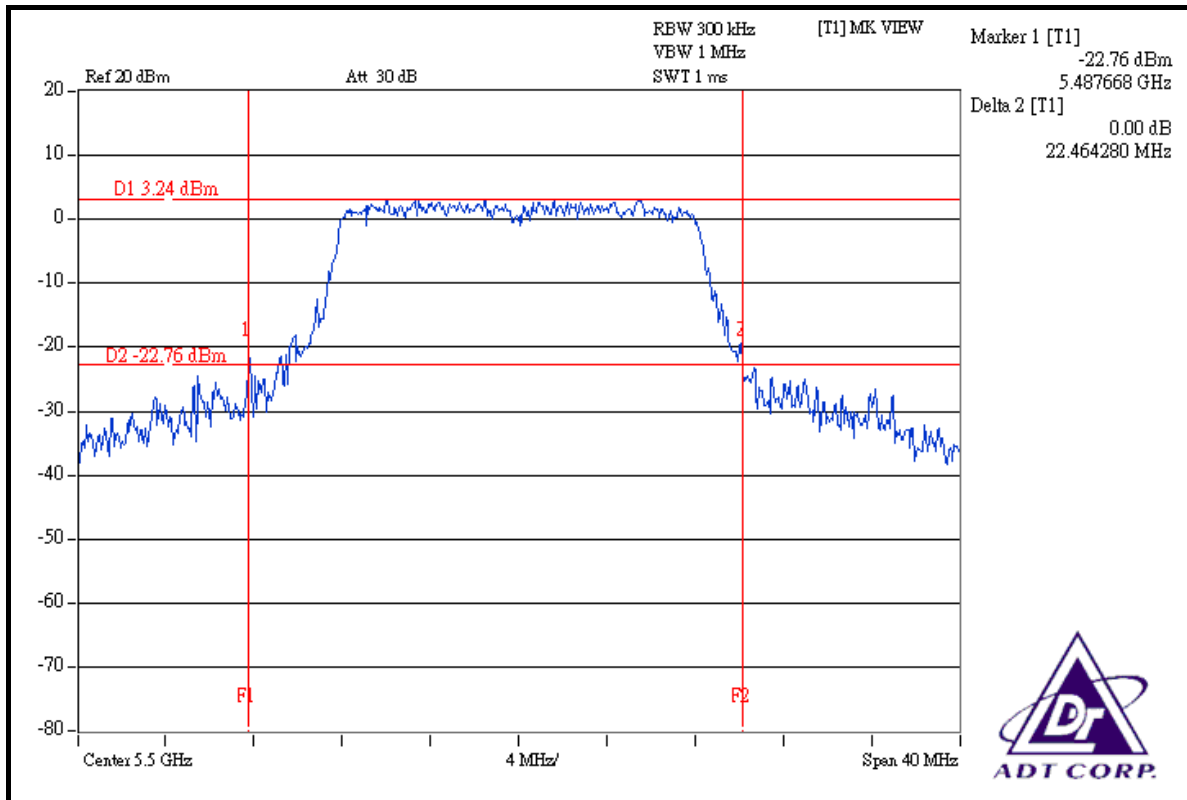

CH 6

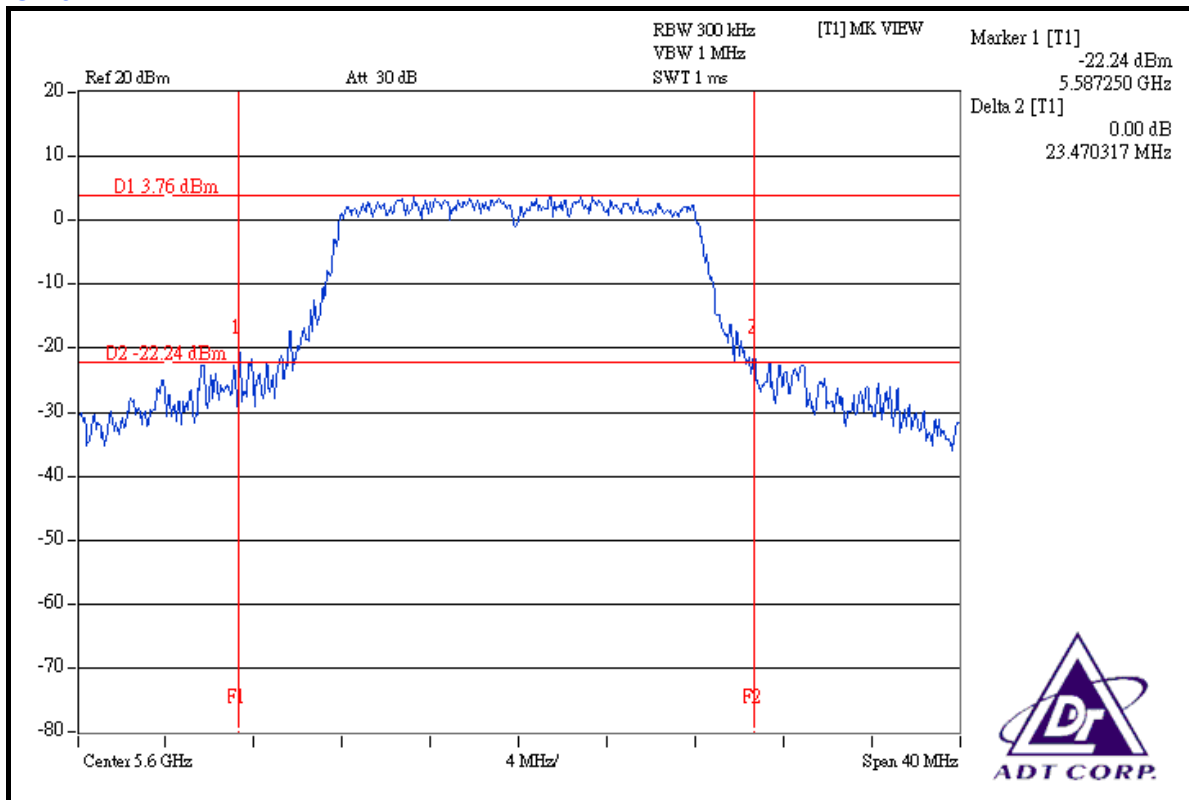

CH 11

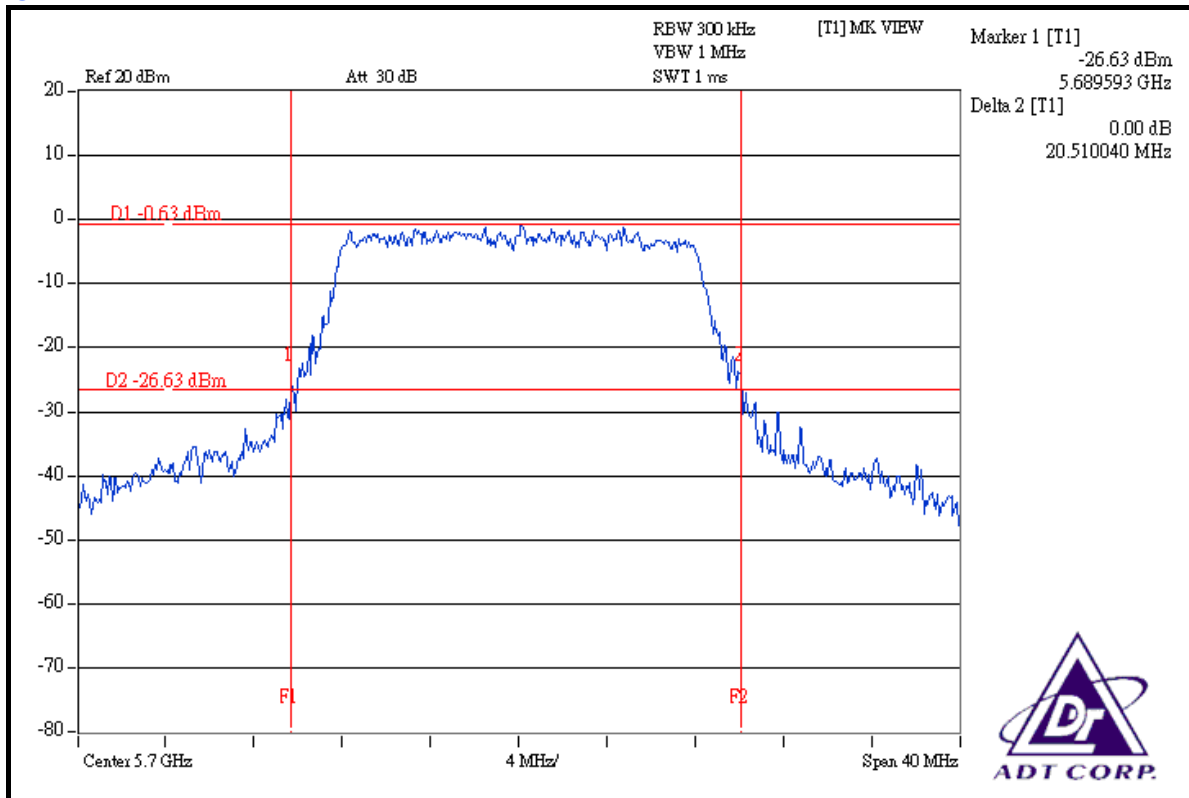

4.4 PEAK POWER EXCURSION MEASUREMENT

4.4.1 LIMITS OF PEAK POWER EXCURSION MEASUREMENT

FREQUENCY BAND	LIMIT
5.150 ~ 5.250GHz	13dB
5.250 ~ 5.350GHz	13dB
5.470 ~ 5.725GHz	13dB

4.4.2 TEST INSTRUMENTS

DESCRIPTION & MANUFACTURER	MODEL NO.	SERIAL NO.	CALIBRATED UNTIL
R&S SPECTRUM ANALYZER	FSP40	100040	Jun. 28, 2008

NOTE: The calibration interval of the above test instruments is 12 months and the calibrations are traceable to NML/ROC and NIST/USA.

4.4.3 TEST PROCEDURE

1. The transmitter output was connected to the spectrum analyzer.
2. Set the spectrum bandwidth span to view the entire spectrum.
3. Using peak detector and Max-hold function for Trace 1 (RB = 1MHz, VB = 3MHz) and 2 (RB = 1MHz, VB = 300kHz).
4. The largest difference between Trace 1 and Trace 2 in any 1MHz band on any frequency was recorded.

4.4.4 DEVIATION FROM TEST STANDARD

No deviation

4.4.5 TEST SETUP

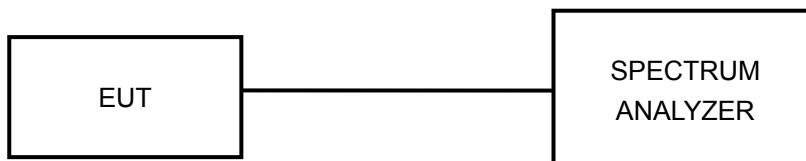

4.4.6 EUT OPERATING CONDITIONS

The software provided by client to enable the EUT under transmission condition continuously at specific channel frequencies individually.



4.4.7 TEST RESULTS

FOR 5150-5350MHz BAND: 802.11a OFDM MODULATION:

MODULATION TYPE	BPSK	ENVIRONMENTAL CONDITIONS	25deg.C, 65%RH, 991hPa
INPUT POWER (SYSTEM)	120Vac, 60Hz	TESTED BY	Brad Wu

CHANNEL	CHANNEL FREQUENCY (MHz)	PEAK POWER EXCURSION (dB)	PEAK TO AVERAGE EXCURSION LIMIT (dB)	PASS / FAIL
1	5180	7.73	13	PASS
2	5200	7.63	13	PASS
4	5240	7.79	13	PASS
5	5260	7.87	13	PASS
7	5300	6.48	13	PASS
8	5320	7.34	13	PASS



CH 1

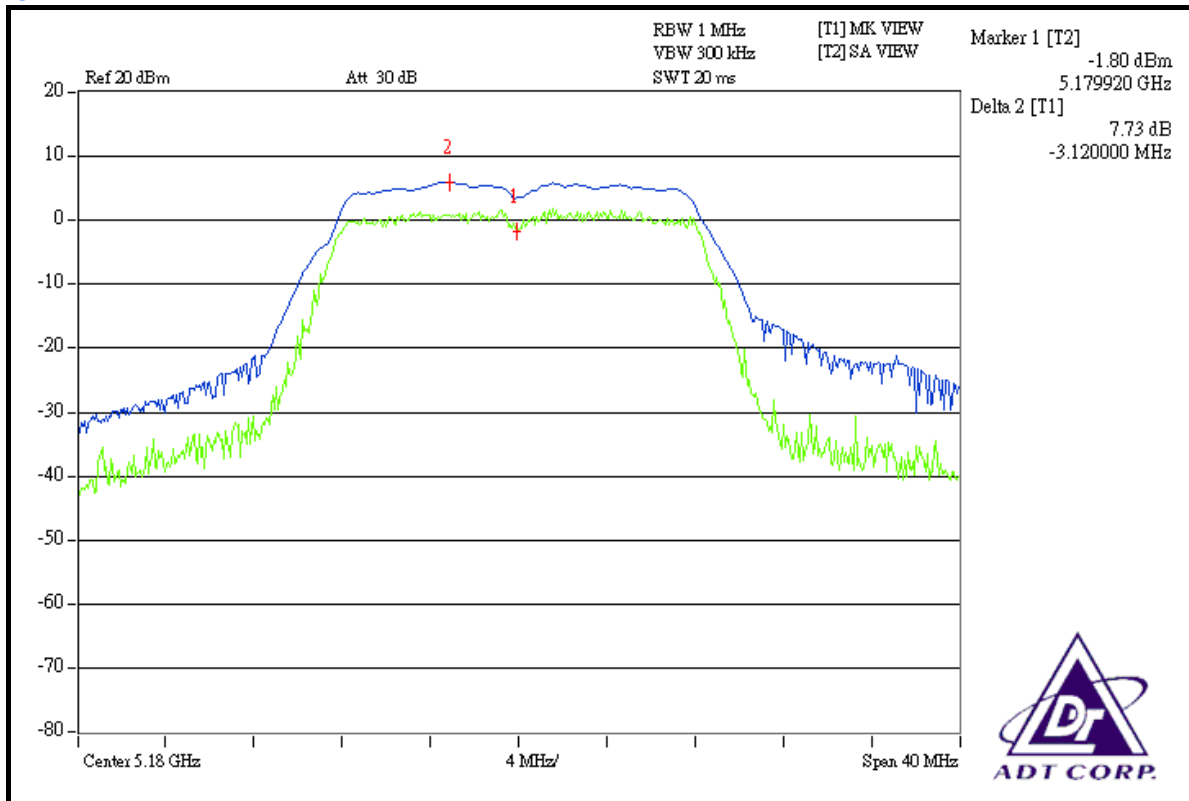

CH 2

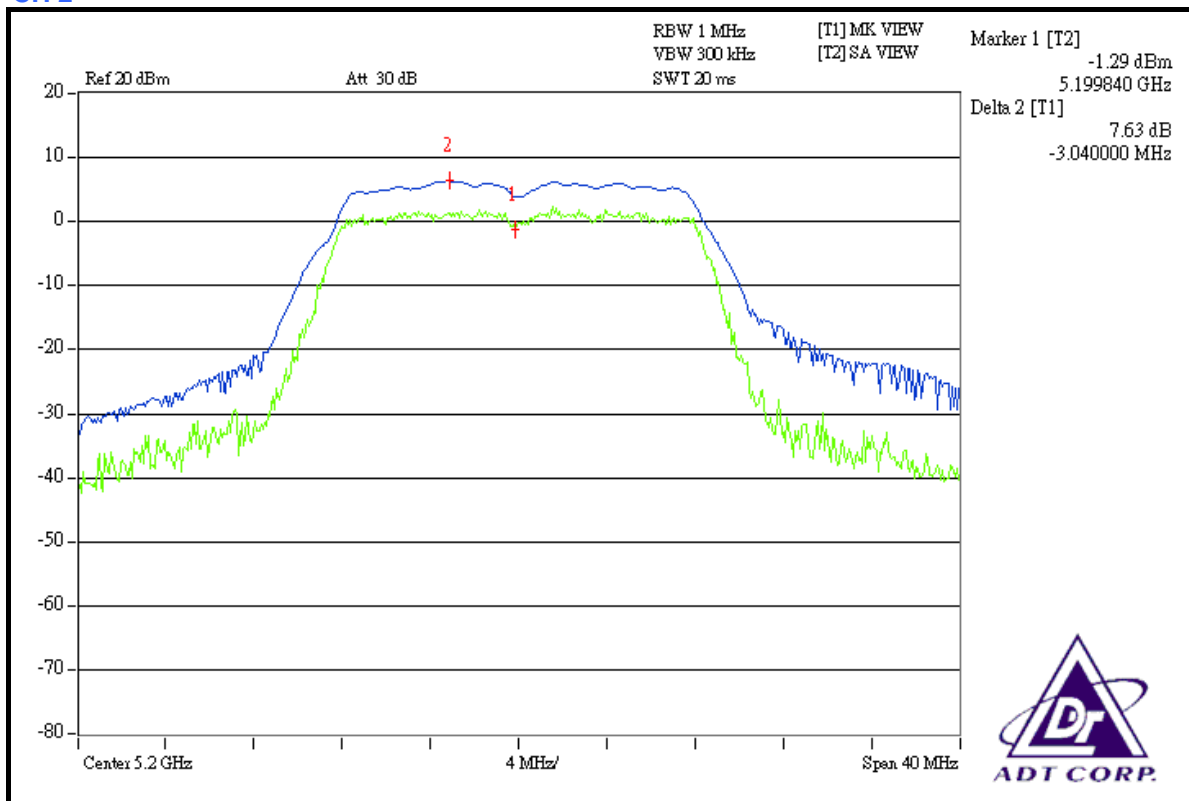



CH 4

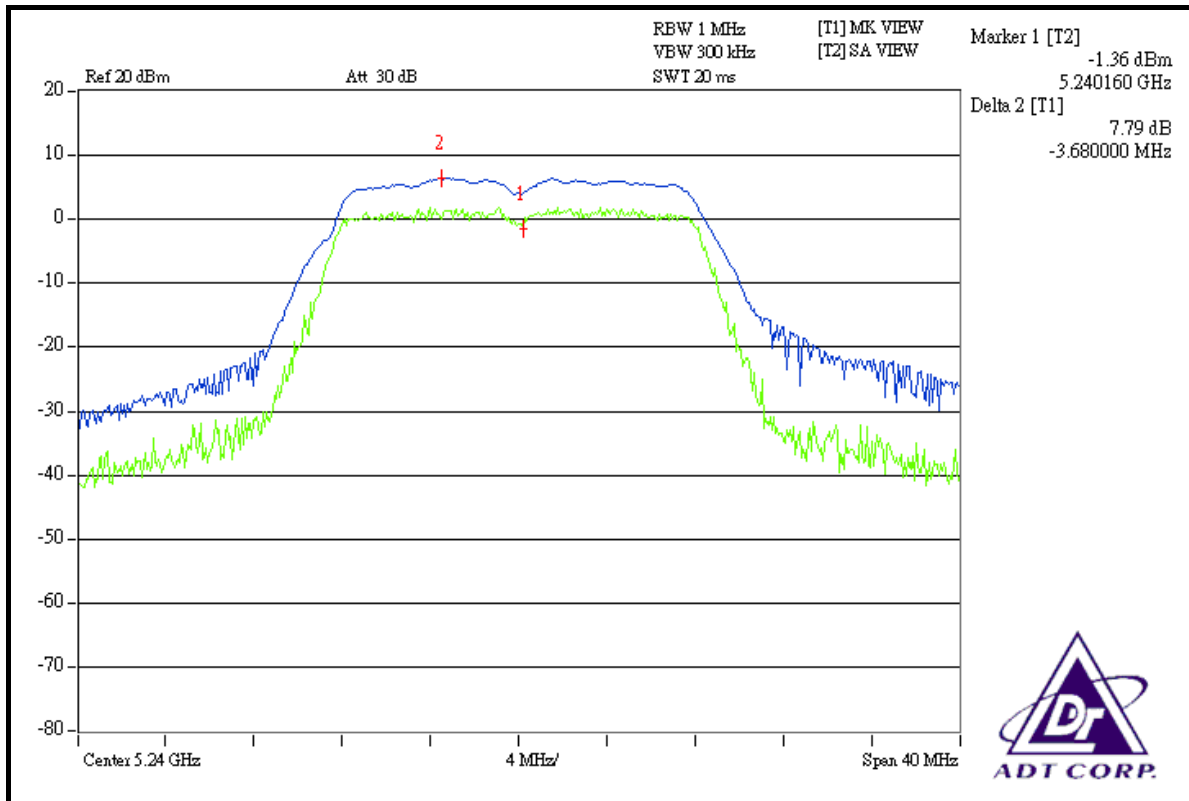

CH 5

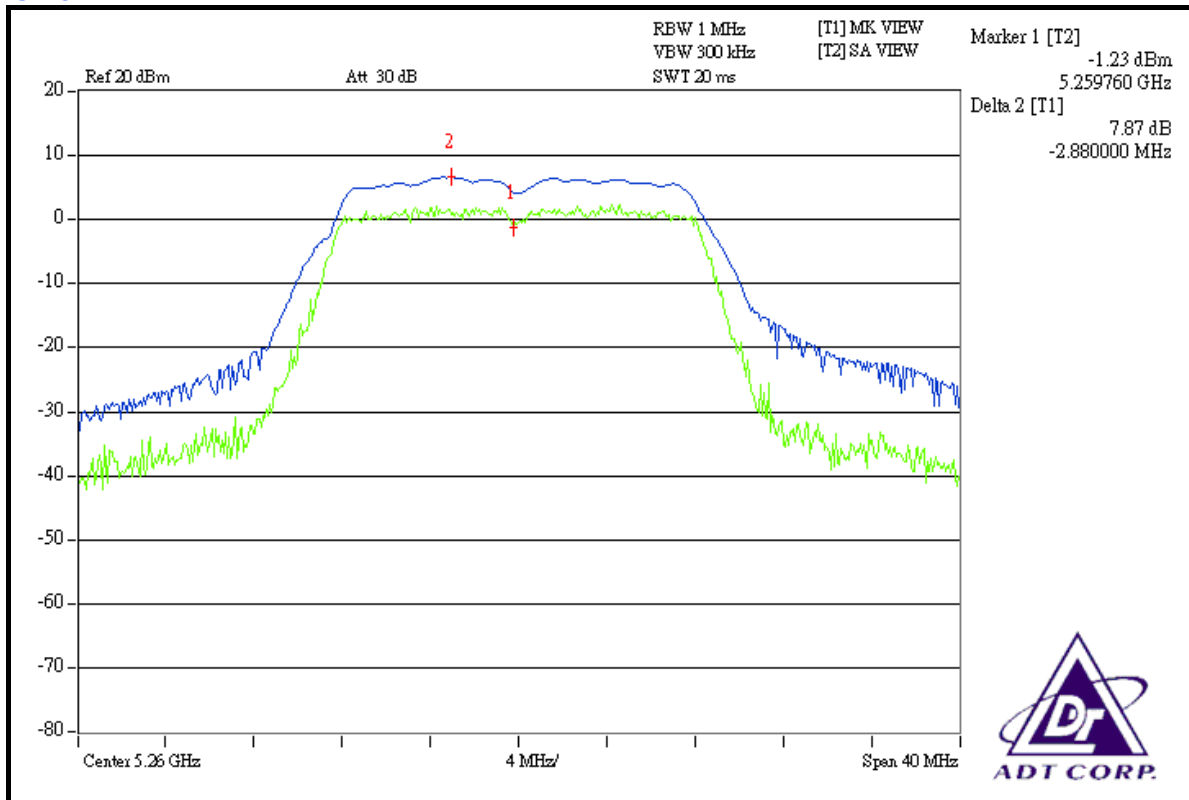



CH 7

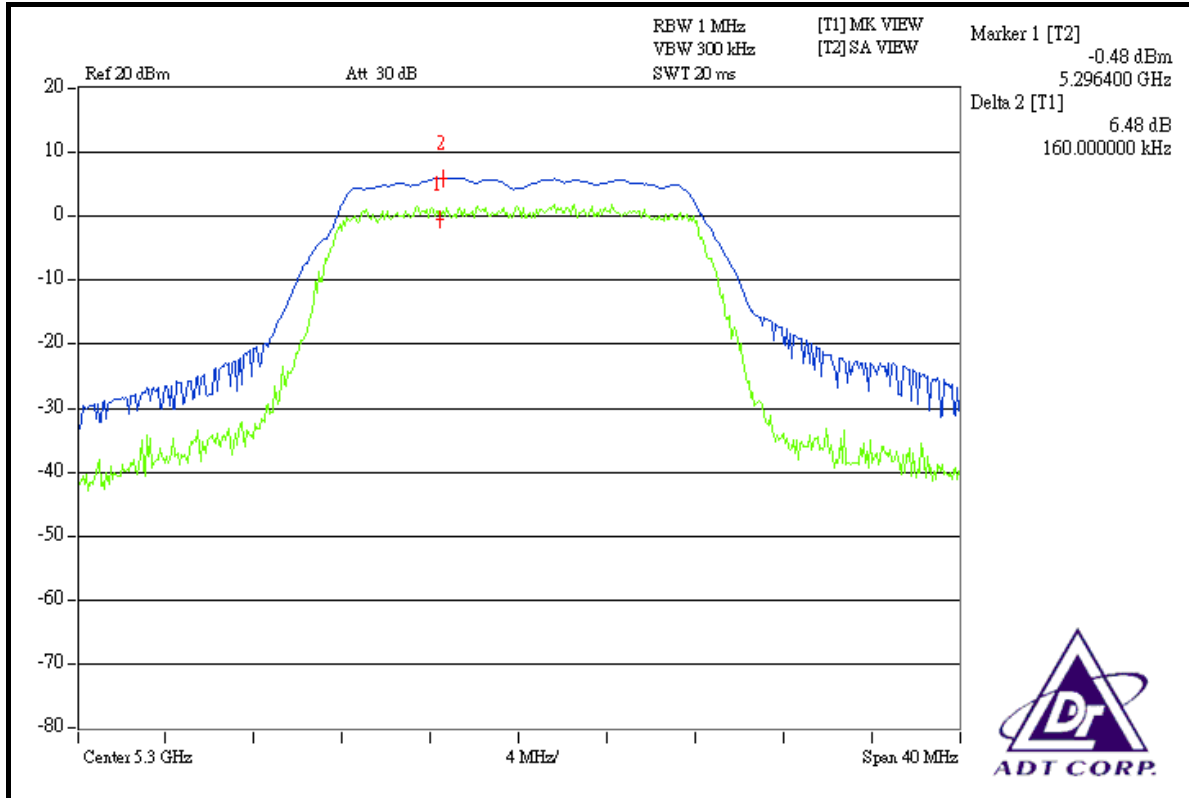

CH 8

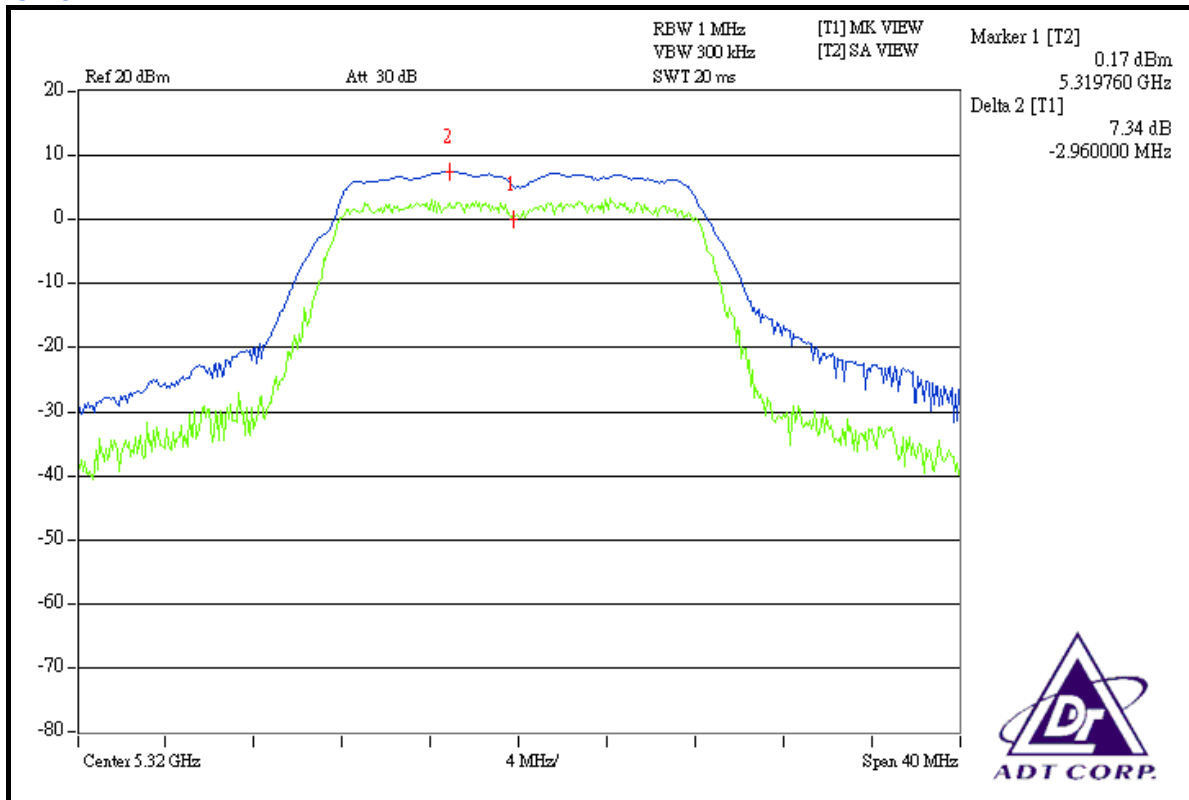



FOR 5470-5725MHz BAND: 802.11a OFDM MODULATION:

MODULATION TYPE	BPSK	ENVIRONMENTAL CONDITIONS	25deg.C, 67%RH, 991hPa
INPUT POWER (SYSTEM)	120Vac, 60Hz	TESTED BY	Brad Wu

CHANNEL	CHANNEL FREQUENCY (MHz)	PEAK POWER EXCURSION (dB)	PEAK TO AVERAGE EXCURSION LIMIT (dB)	PASS / FAIL
1	5500	7.32	13	PASS
6	5600	7.45	13	PASS
11	5700	6.45	13	PASS

CH 1

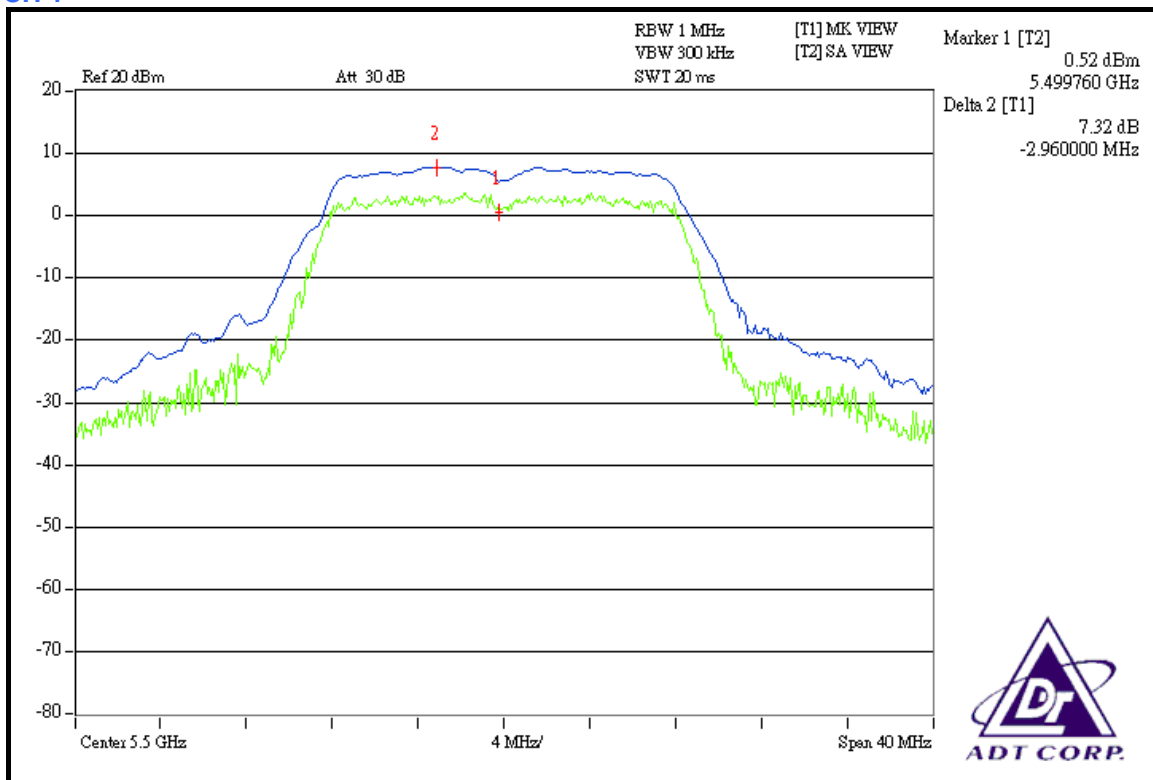

CH 6

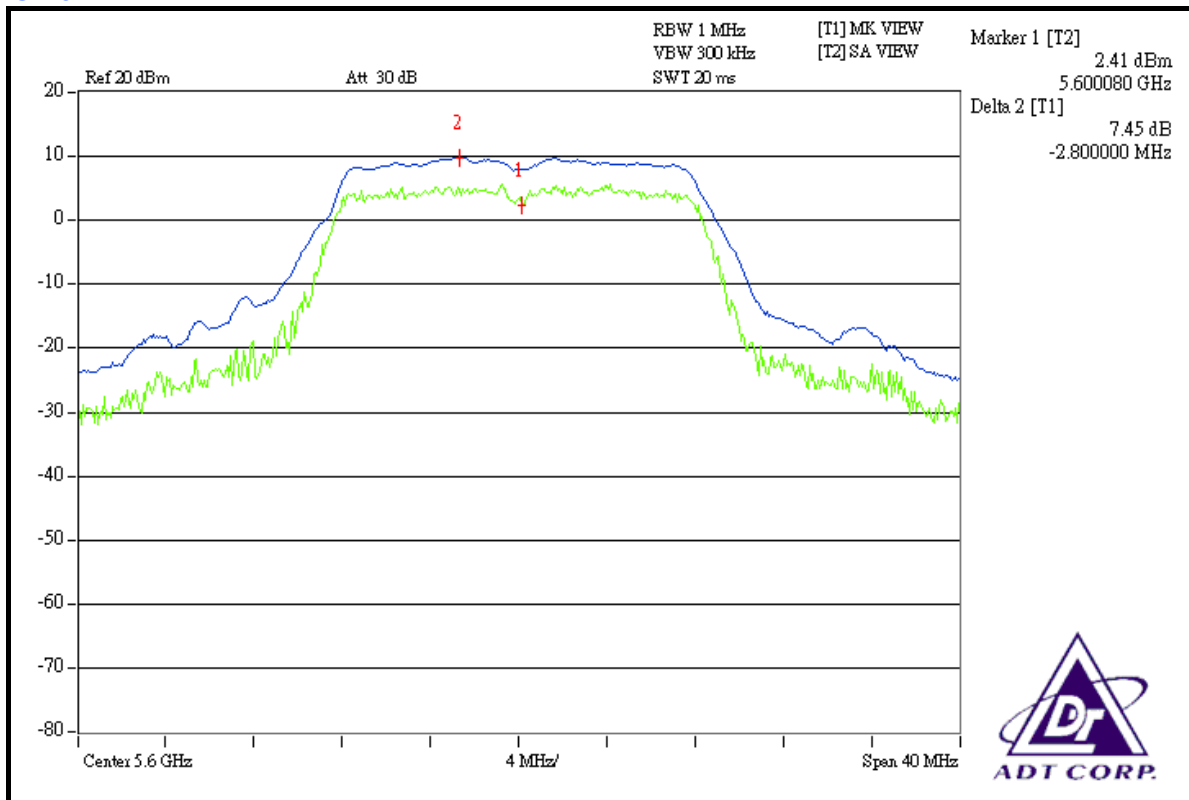

CH 11

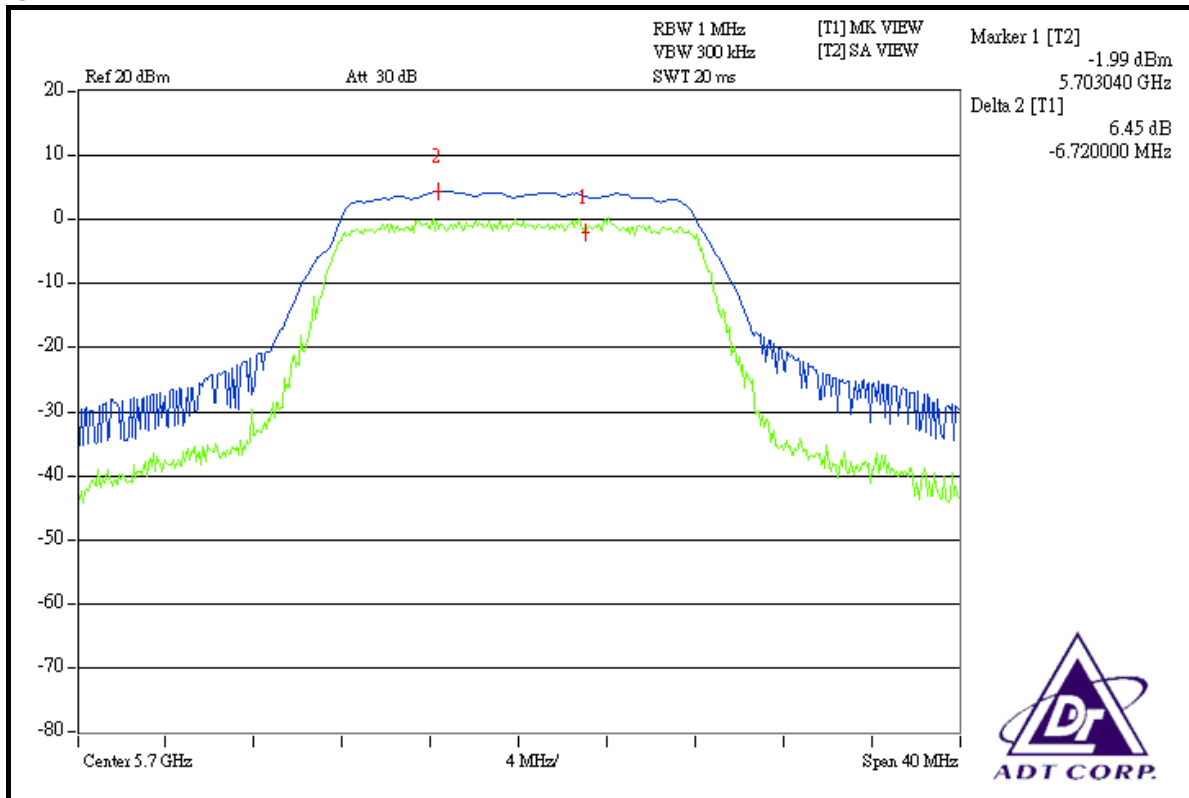



4.5 PEAK POWER SPECTRAL DENSITY MEASUREMENT

4.5.1 LIMITS OF PEAK POWER SPECTRAL DENSITY MEASUREMENT

FREQUENCY BAND	LIMIT
5.150 ~ 5.250GHz	4dBm
5.250 ~ 5.350GHz	11dBm
5.470 ~ 5.725GHz	11dBm

4.5.2 TEST INSTRUMENTS

DESCRIPTION & MANUFACTURER	MODEL NO.	SERIAL NO.	CALIBRATED UNTIL
R&S SPECTRUM ANALYZER	FSP40	100040	Jun. 28, 2008

NOTE: The calibration interval of the above test instruments is 12 months and the calibrations are traceable to NML/ROC and NIST/USA.

4.5.3 TEST PROCEDURES

- a. The transmitter output was connected to the spectrum analyzer.
- b. Set RBW = 1MHz, VBW = 3MHz. The PPSD is the highest level found across the emission in any 1MHz band.

4.5.4 DEVIATION FROM TEST STANDARD

No deviation

4.5.5 TEST SETUP

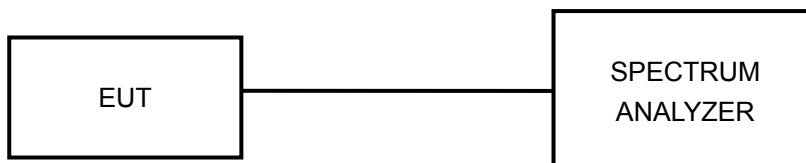

4.5.6 EUT OPERATING CONDITIONS

The software provided by client to enable the EUT under transmission condition continuously at specific channel frequencies individually.



4.5.7 TEST RESULTS

FOR 5150-5350MHz BAND: 802.11a OFDM MODULATION:

MODULATION TYPE	BPSK	ENVIRONMENTAL CONDITIONS	25deg.C, 65%RH, 991hPa
INPUT POWER (SYSTEM)	120Vac, 60Hz	TESTED BY	Brad Wu

CHANNEL	CHANNEL FREQUENCY (MHz)	RF POWER LEVEL IN 1MHz BW (dBm)	MAXIMUM LIMIT (dBm)	PASS / FAIL
1	5180	-4.32	4	PASS
2	5200	-4.07	4	PASS
4	5240	-4.14	4	PASS
5	5260	-4.09	11	PASS
7	5300	-3.64	11	PASS
8	5320	-2.94	11	PASS



CH 1

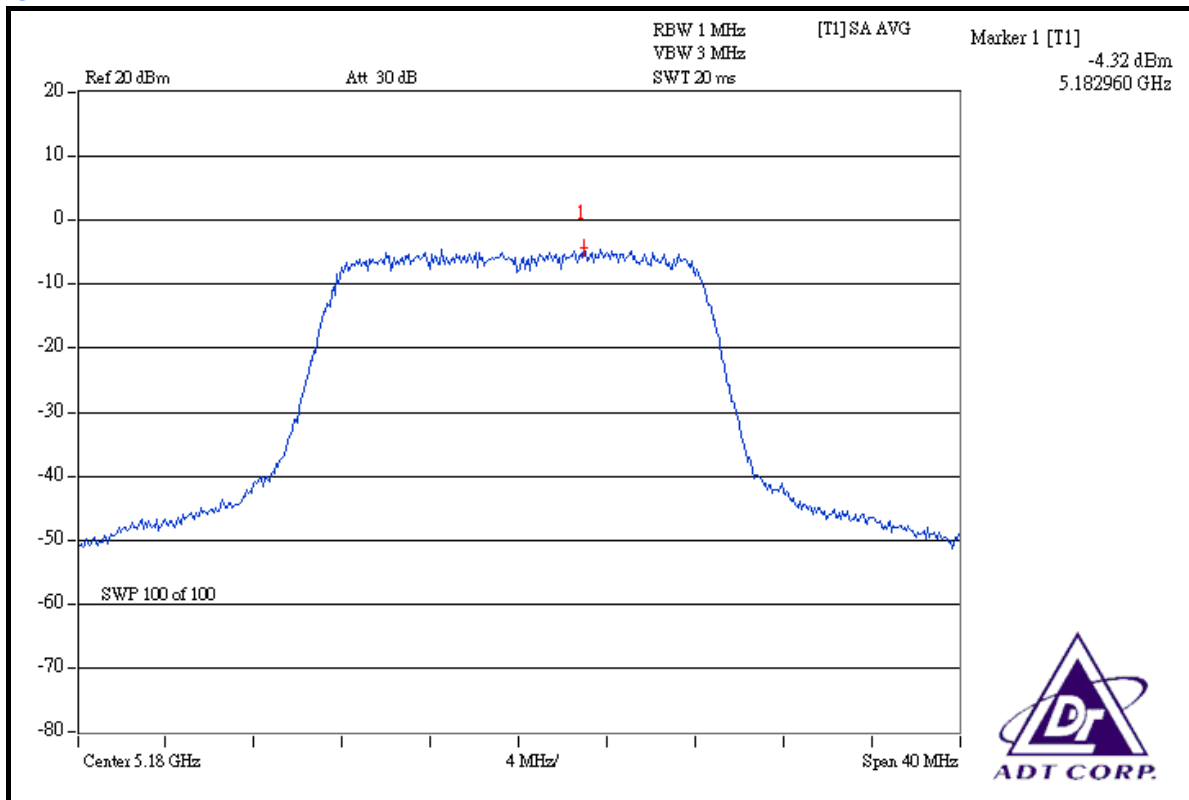

CH 2

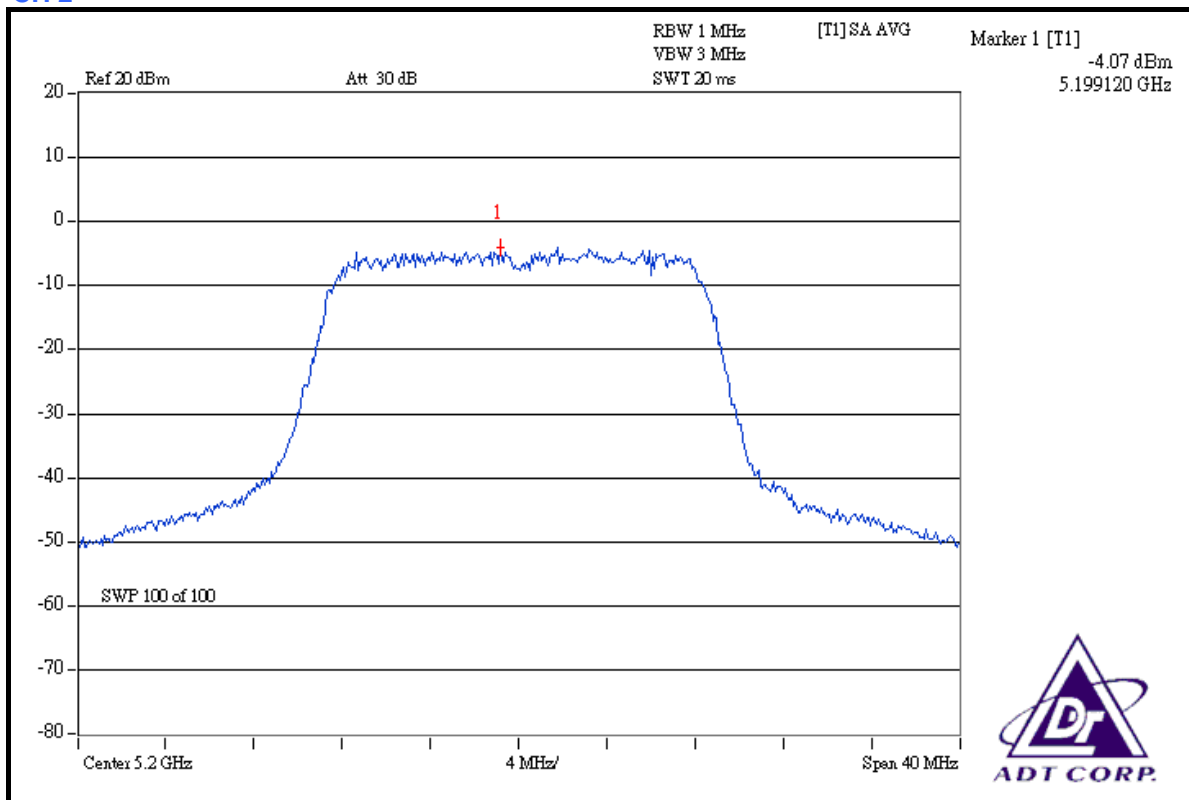

CH 4

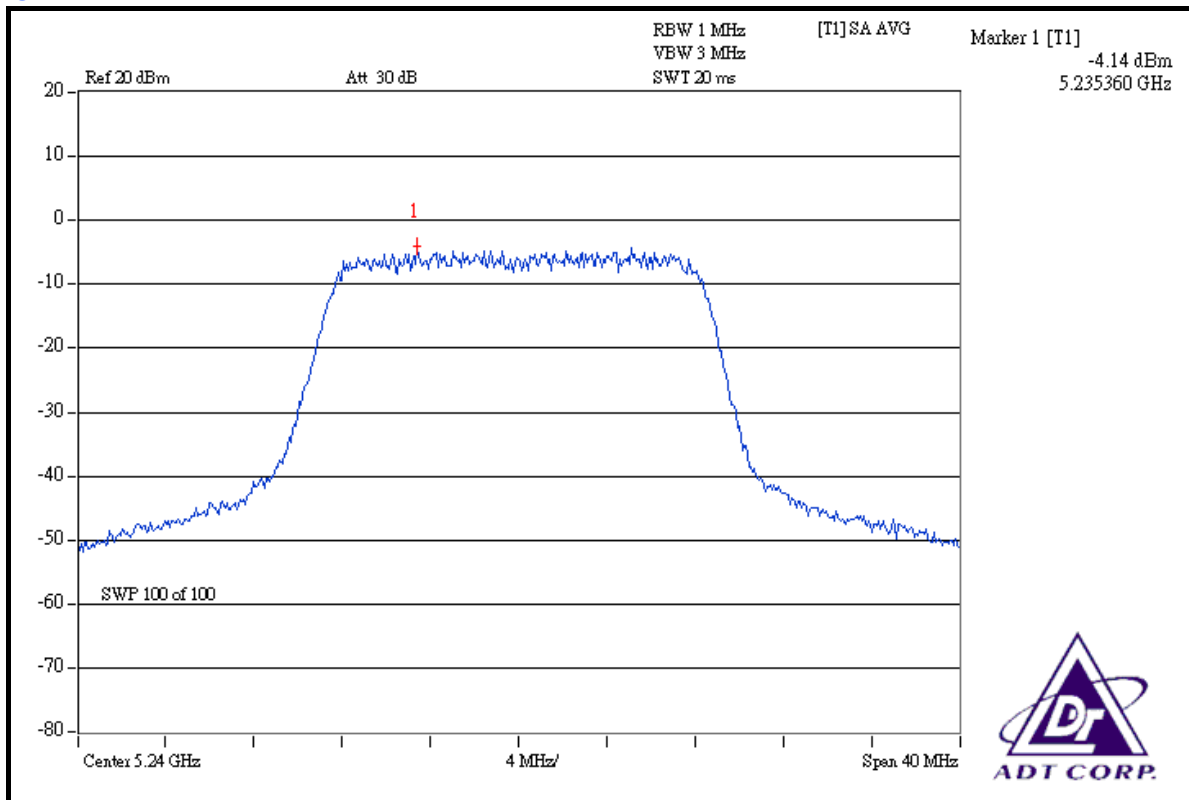

CH 5

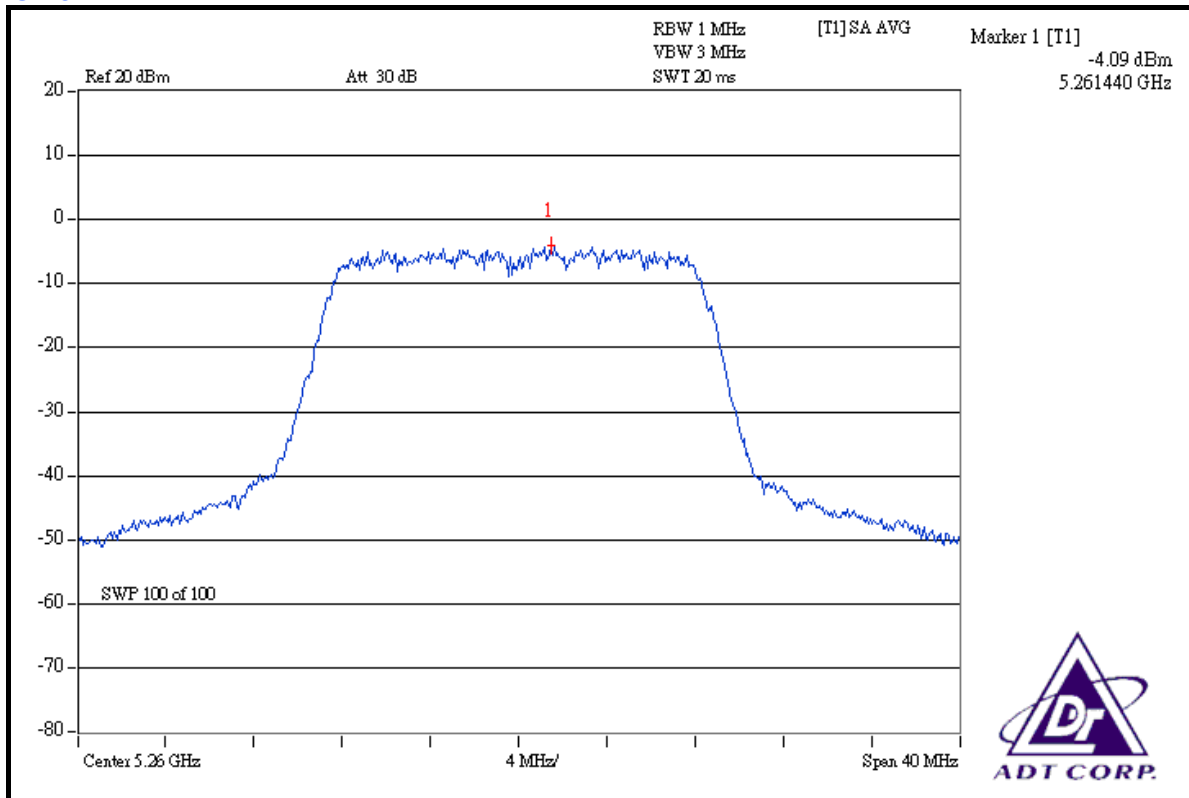

CH 7

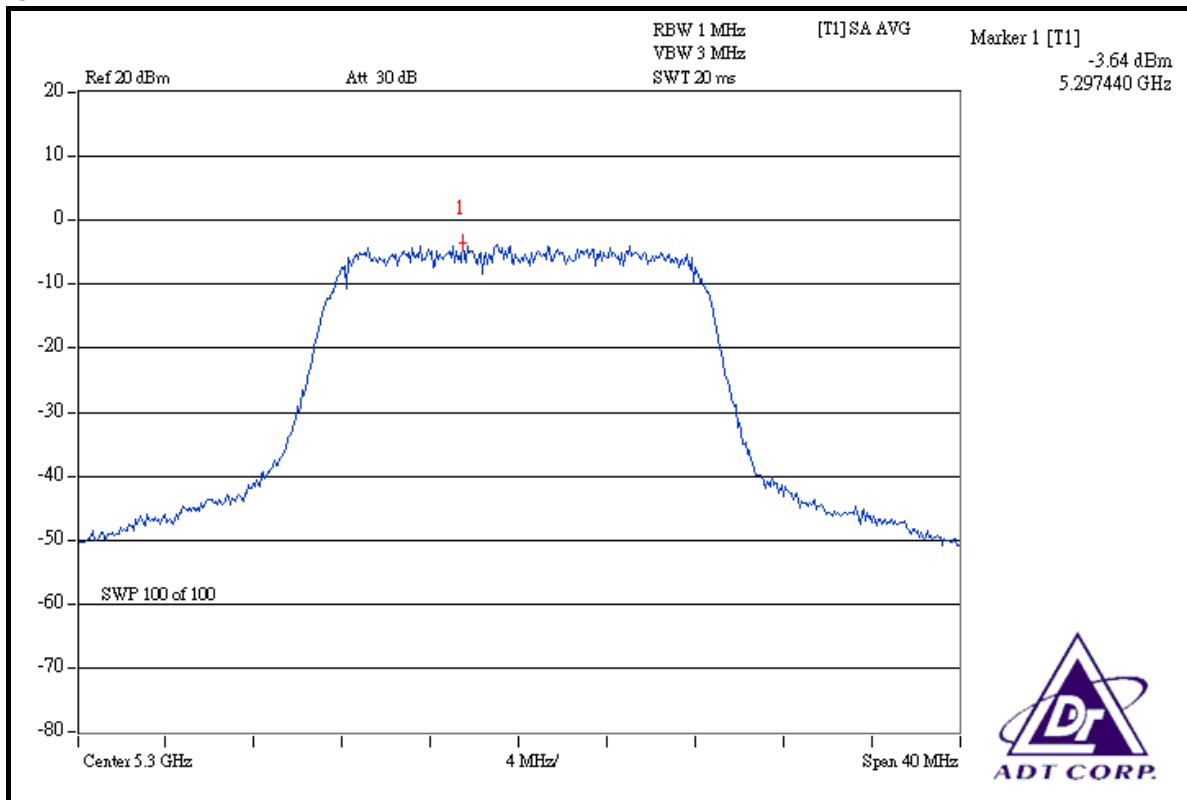

CH 8

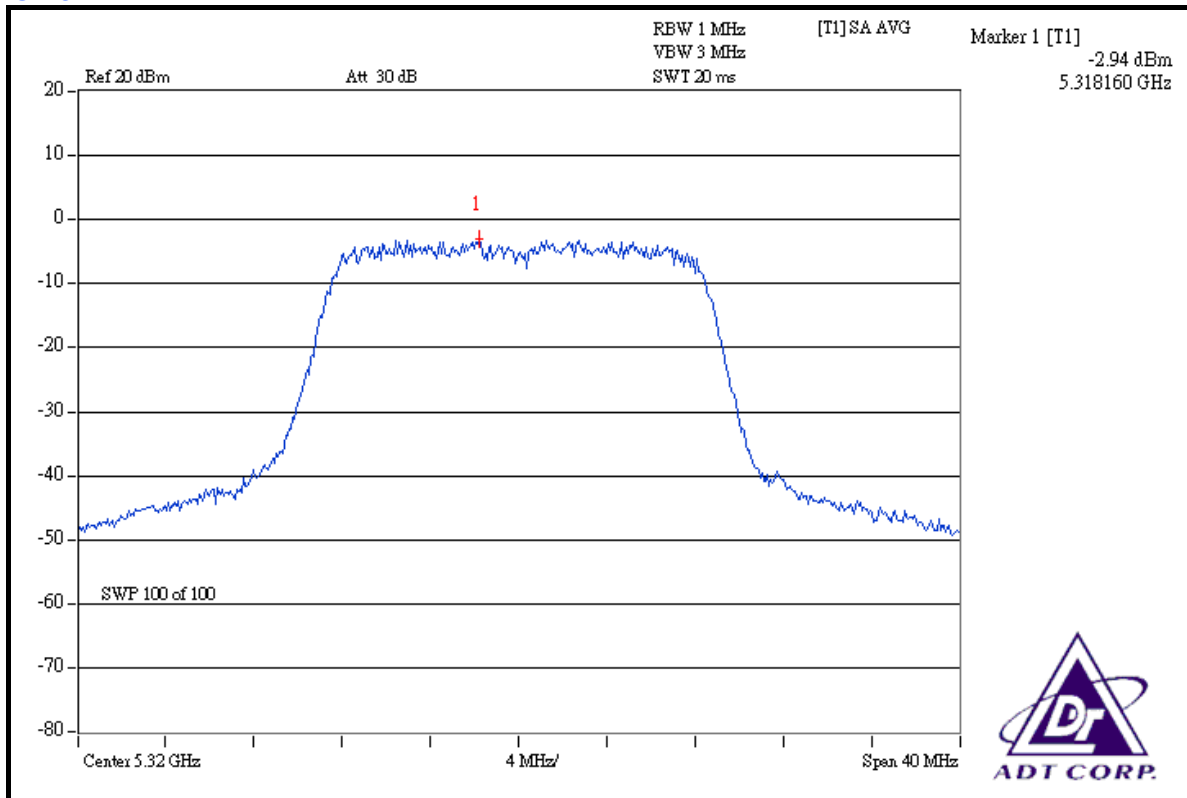



FOR 5470-5725MHz BAND: 802.11a OFDM MODULATION:

MODULATION TYPE	BPSK	ENVIRONMENTAL CONDITIONS	25deg.C, 67%RH, 991hPa
INPUT POWER (SYSTEM)	120Vac, 60Hz	TESTED BY	Brad Wu

CHANNEL	CHANNEL FREQUENCY (MHz)	RF POWER LEVEL IN 1MHz BW (dBm)	MAXIMUM LIMIT (dBm)	PASS / FAIL
1	5500	-2.59	11	PASS
6	5600	-0.72	11	PASS
11	5700	-5.88	11	PASS

CH 1

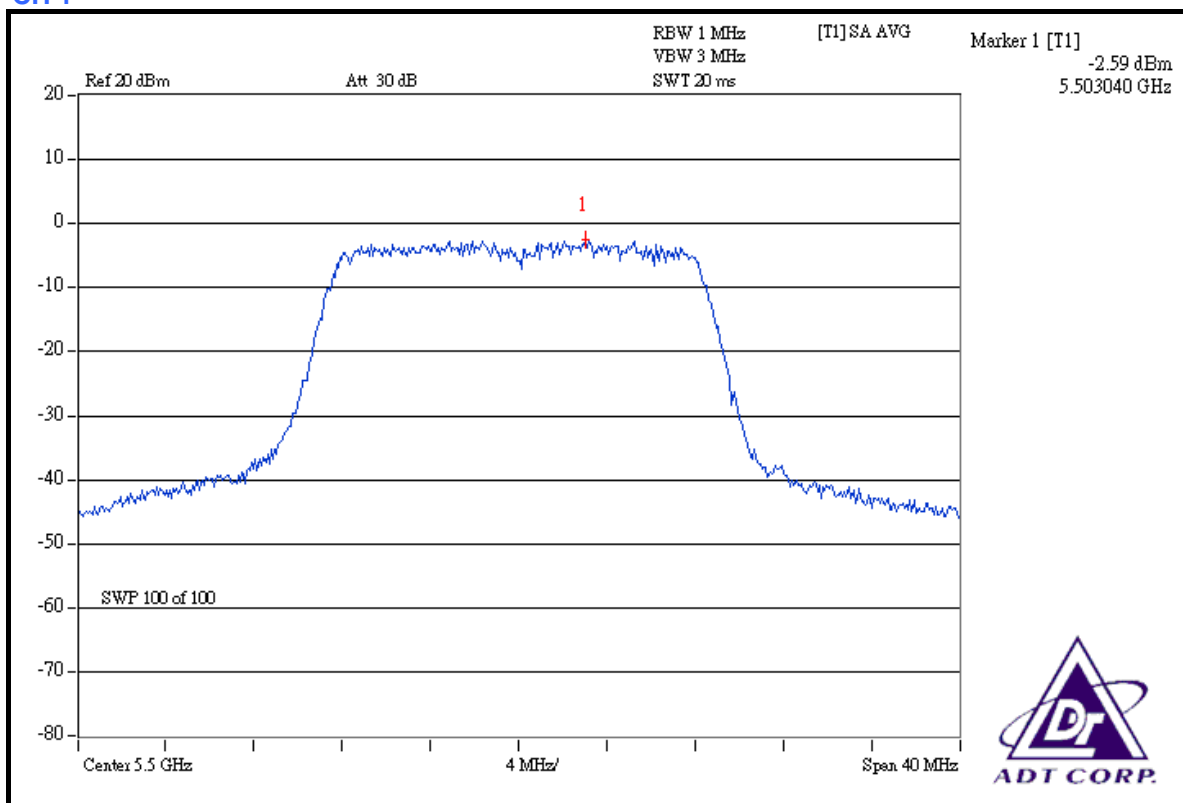



CH 6

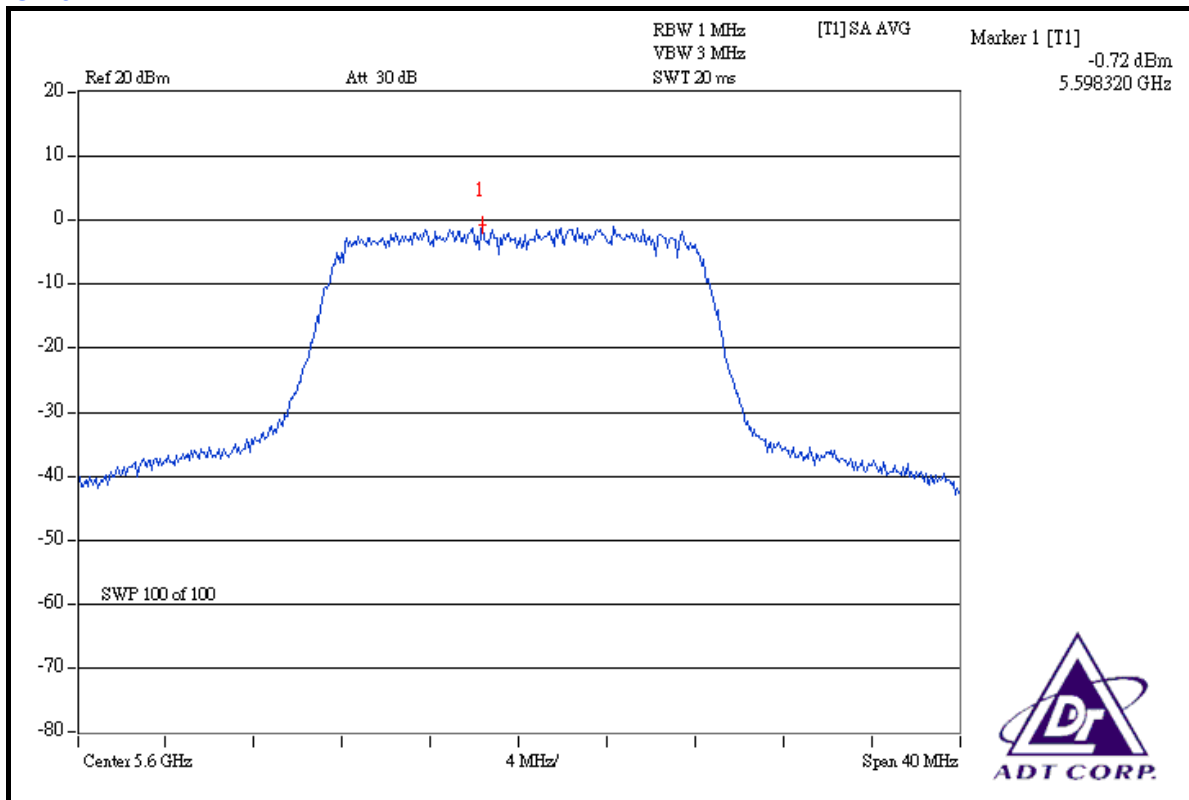

CH 11

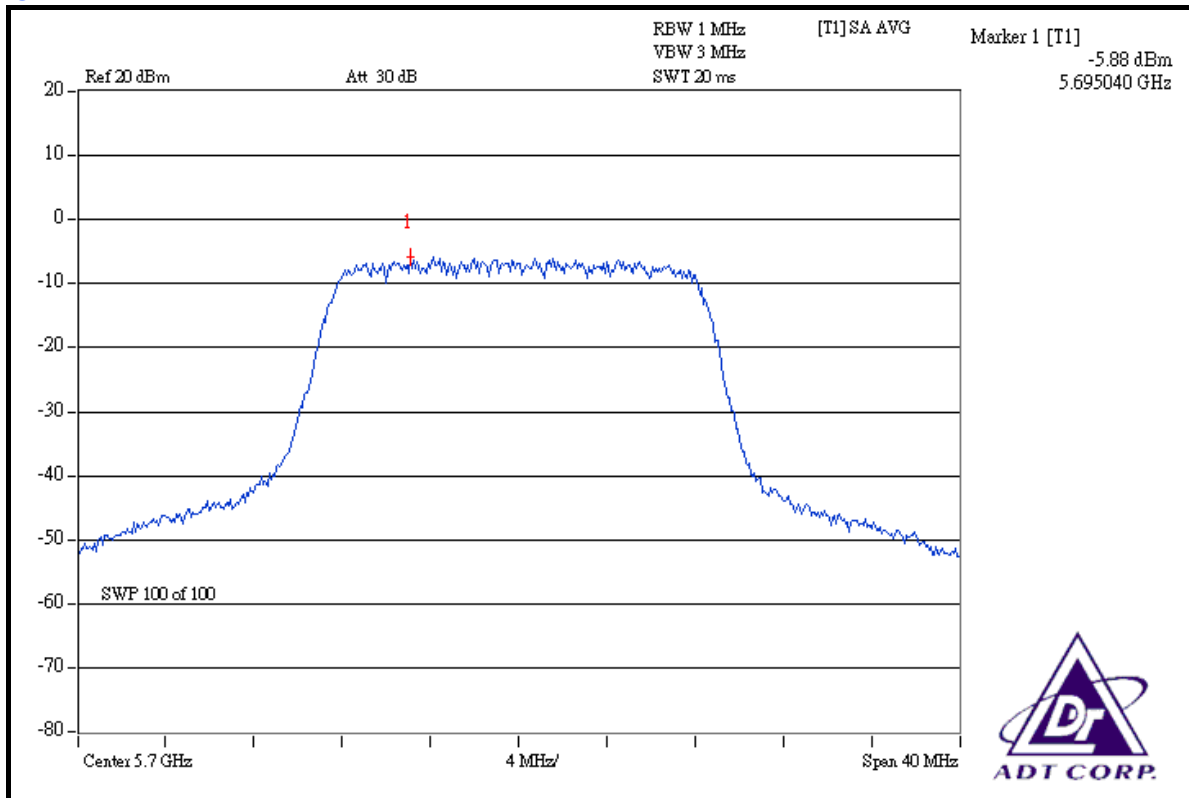



4.6 FREQUENCY STABILITY

4.6.1 LIMITS OF FREQUENCY STABILITY MEASUREMENT

The frequency tolerance of the carrier signal shall be maintained within +/- 0.02% of the operating frequency over a temperature variation of -30 degrees to 50 degrees C at normal supply voltage, and for a variation in the primary supply voltage from 85% to 115% of the rated supply voltage at a temperature of 20 degrees C.

4.6.2 TEST INSTRUMENTS

DESCRIPTION & MANUFACTURER	MODEL NO.	SERIAL NO.	CALIBRATED UNTIL
ANRITSU SPECTRUM ANALYZER	MS2667C	M10281	Mar. 07, 2008
WIT STANDARD TEMPERATURE AND HUMIDITY CHAMBER	TH-4S-C	W981030	Jun. 28, 2008

NOTE: The calibration interval of the above test instruments is 12 months and the calibrations are traceable to NML/ROC and NIST/USA.

4.6.3 TEST PROCEDURE

1. The EUT was placed inside the environmental test chamber and powered by nominal DC voltage.
2. Turn the EUT on and couple its output to a spectrum analyzer.
3. Turn the EUT off and set the chamber to the highest temperature specified.
4. Allow sufficient time (approximately 30 min) for the temperature of the chamber to stabilize, turn the EUT on and measure the operating frequency after 2, 5, and 10 minutes.
5. Repeat step 2 and 3 with the temperature chamber set to the lowest temperature.
6. The test chamber was allowed to stabilize at +20 degree C for a minimum of 30 minutes. The supply voltage was then adjusted on the EUT from 85% to 115% and the frequency record.

4.6.4 DEVIATION FROM TEST STANDARD

No deviation

4.6.5 TEST SETUP

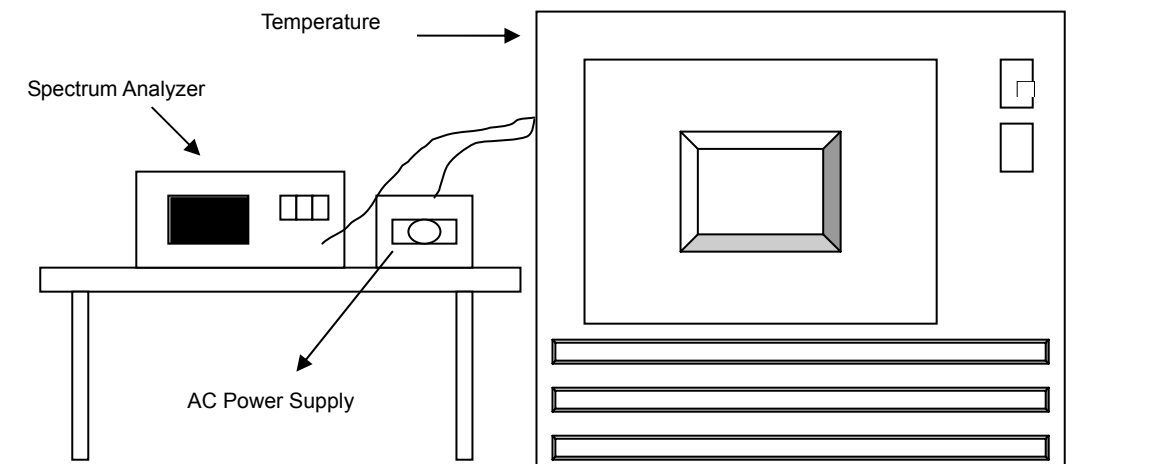

4.6.6 EUT OPERATING CONDITION

Same as Item 4.1.6



4.6.7 TEST RESULTS

OPERATING FREQUENCY: 5320MHz						LIMIT: $\pm 0.01\%$			
TEMP. (°C)	POWER SUPPLY (Vac)	0 MINUTE		2 MINUTE		5 MINUTE		10 MINUTE	
		(MHz)	(%)	(MHz)	(%)	(MHz)	(%)	(MHz)	(%)
50	126.5	5319.907652	-0.0017359	5319.917944	-0.0015424	5319.942163	-0.0010872	5319.937655	-0.0011719
	110.0	5319.923825	-0.0014319	5319.929954	-0.0013166	5319.944684	-0.0010398	5319.946452	-0.0010065
	93.5	5319.928441	-0.0013451	5319.930345	-0.0013093	5319.948554	-0.0009670	5319.949872	-0.0009422
40	126.5	5319.915663	-0.0015853	5319.926946	-0.0013732	5319.946054	-0.0010140	5319.944586	-0.0010416
	110.0	5319.924851	-0.0014126	5319.935744	-0.0012078	5319.953654	-0.0008712	5319.948321	-0.0009714
	93.5	5319.935921	-0.0012045	5319.943544	-0.0010612	5319.952854	-0.0008862	5319.955525	-0.0008360
30	126.5	5319.920441	-0.0014955	5319.933057	-0.0012583	5319.952254	-0.0008975	5319.948672	-0.0009648
	110.0	5319.925865	-0.0013935	5319.948649	-0.0009652	5319.959454	-0.0007621	5319.948541	-0.0009673
	93.5	5319.943961	-0.0010534	5319.957041	-0.0008075	5319.958634	-0.0007776	5319.962253	-0.0007095
20	126.5	5319.92681	-0.0013757	5319.93695	-0.0011852	5319.955334	-0.0008396	5319.956924	-0.0008097
	110.0	5319.92691	-0.0013739	5319.954343	-0.0008582	5319.963844	-0.0006796	5319.958372	-0.0007825
	93.5	5319.951731	-0.0009073	5319.965545	-0.0006477	5319.964262	-0.0006718	5319.963425	-0.0006875
10	126.5	5319.933851	-0.0012434	5319.947742	-0.0009823	5319.962484	-0.0007052	5319.964253	-0.0006719
	110.0	5319.942866	-0.0010739	5319.958643	-0.0007774	5319.96434	-0.0006703	5319.963617	-0.0006839
	93.5	5319.958451	-0.0007810	5319.970343	-0.0005575	5319.972444	-0.0005180	5319.973471	-0.0004987
0	126.5	5319.937251	-0.0011795	5319.954742	-0.0008507	5319.964864	-0.0006604	5319.966254	-0.0006343
	110.0	5319.948621	-0.0009658	5319.964143	-0.0006740	5319.973424	-0.0004995	5319.968829	-0.0005859
	93.5	5319.96465	-0.0006645	5319.972945	-0.0005086	5319.975214	-0.0004659	5319.976428	-0.0004431
-10	126.5	5319.950356	-0.0009332	5319.963483	-0.0006864	5319.973654	-0.0004952	5319.971887	-0.0005284
	110.0	5319.946596	-0.0010038	5319.971453	-0.0005366	5319.976834	-0.0004354	5319.978253	-0.0004088
	93.5	5319.971247	-0.0005405	5319.976598	-0.0004399	5319.978854	-0.0003975	5319.978571	-0.0004028
-20	126.5	5319.955042	-0.0008451	5319.966621	-0.0006274	5319.976364	-0.0004443	5319.977458	-0.0004237
	110.0	5319.960445	-0.0007435	5319.974593	-0.0004776	5319.983465	-0.0003108	5319.978721	-0.0004000
	93.5	5319.975246	-0.0004653	5319.984034	-0.0003001	5319.984182	-0.0002973	5319.981354	-0.0003505
-30	126.5	5319.960325	-0.0007458	5319.973563	-0.0004969	5319.983687	-0.0003066	5319.979665	-0.0003822
	110.0	5319.974745	-0.0004747	5319.979833	-0.0003791	5319.985151	-0.0002791	5319.984265	-0.0002958
	93.5	5319.977844	-0.0004165	5319.989353	-0.0002001	5319.987244	-0.0002398	5319.985897	-0.0002651



4.7 BAND EDGES MEASUREMENT

4.7.1 TEST INSTRUMENTS

DESCRIPTION & MANUFACTURER	MODEL NO.	SERIAL NO.	CALIBRATED UNTIL
R&S SPECTRUM ANALYZER	FSP40	100040	Jun. 28, 2008

NOTE: The calibration interval of the above test instruments is 12 months and the calibrations are traceable to NML/ROC and NIST/USA

4.7.2 TEST PROCEDURE

The transmitter output was connected to the spectrum analyzer via a low lose cable. Set both RBW and VBW of spectrum analyzer to 1MHz / 3MHz with suitable frequency span including 100MHz bandwidth from band edge. The band edges was measured and recorded.

NOTE: The resolution bandwidth of test receiver/spectrum analyzer is 1MHz and the video bandwidth is 10Hz for Average detection (AV) at frequency above 1GHz

4.7.3 EUT OPERATING CONDITION

The software provided by client to enable the EUT under transmission condition continuously at specific channel frequencies individually.

4.7.4 TEST RESULTS

For signals in the restricted bands above and below the 5.15 to 5.35GHz and 5.47 to 5.725GHz allocated band a measurement was made of the amplitude of the spurious emissions with respect to the intentional signals. The relative amplitude, in dBc, was applied to the average and peak filed strength of the intentional signal made on the OATS to calculate the field strength of the unintentional signals.

The spectrum plots (Peak RBW = 1MHz, VBW = 3MHz) are attached on the following pages.

FOR 5150-5350MHz BAND: 802.11a OFDM MODULATION:

Channel 1 (5180MHz)

The band edge emission plot on the next page shows 44.05dBc between carrier maximum power and local maximum emission in restrict band. The emission of carrier strength list in the test result of channel 1 is 102.91dBuV/m (Peak), so the maximum field strength in restrict band is $102.91 - 44.05 = 58.86$ dBuV/m which is under 74dBuV/m limit.

The band edge emission plot on the next page shows 50.07dBc between carrier maximum power and local maximum emission in restrict band. The emission of carrier strength list in the test result of channel 1 is 92.23dBuV/m (Average), so the maximum field strength in restrict band is $92.23 - 50.07 = 42.16$ dBuV/m which is under 54dBuV/m limit.

Channel 8 (5320MHz)

The band edge emission plot on the next second page shows 41.01dBc between carrier maximum power and local maximum emission in restrict band. The emission of carrier strength list in the test result of channel 8 is 103.05dBuV/m (Peak), so the maximum field strength in restrict band is $103.05 - 41.01 = 62.04$ dBuV/m which is under 74dBuV/m limit.

The band edge emission plot on the next third page shows 49.90dBc between carrier maximum power and local maximum emission in restrict band. The emission of carrier strength list in the test result of channel 8 is 92.61dBuV/m (Average), so the maximum field strength in restrict band is $92.61 - 49.90 = 42.71$ dBuV/m which is under 54dBuV/m limit.

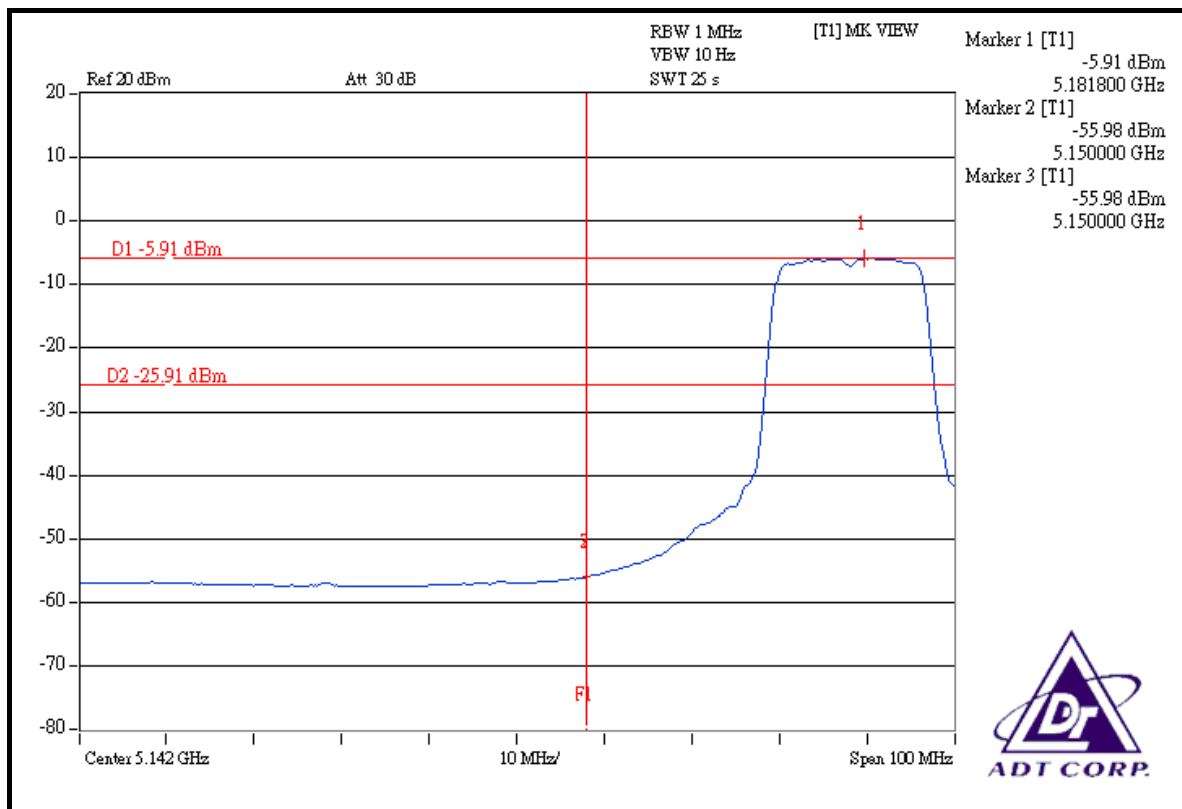
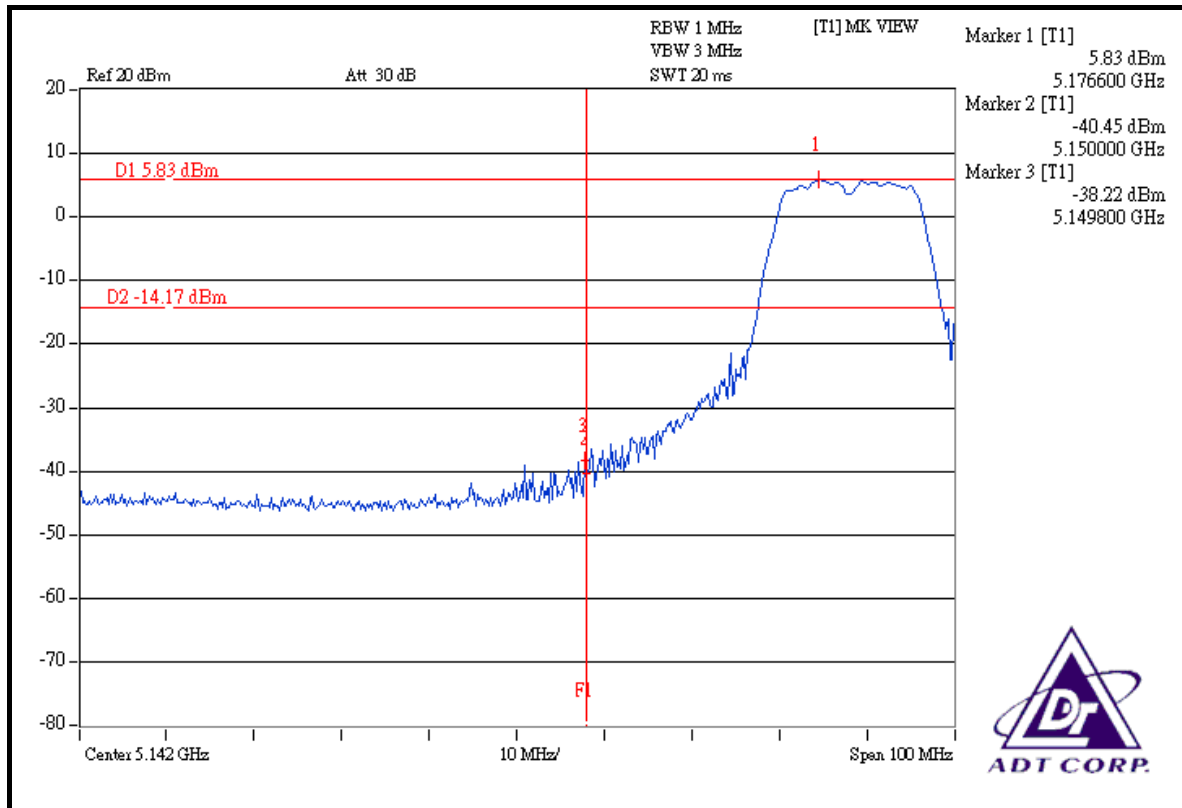

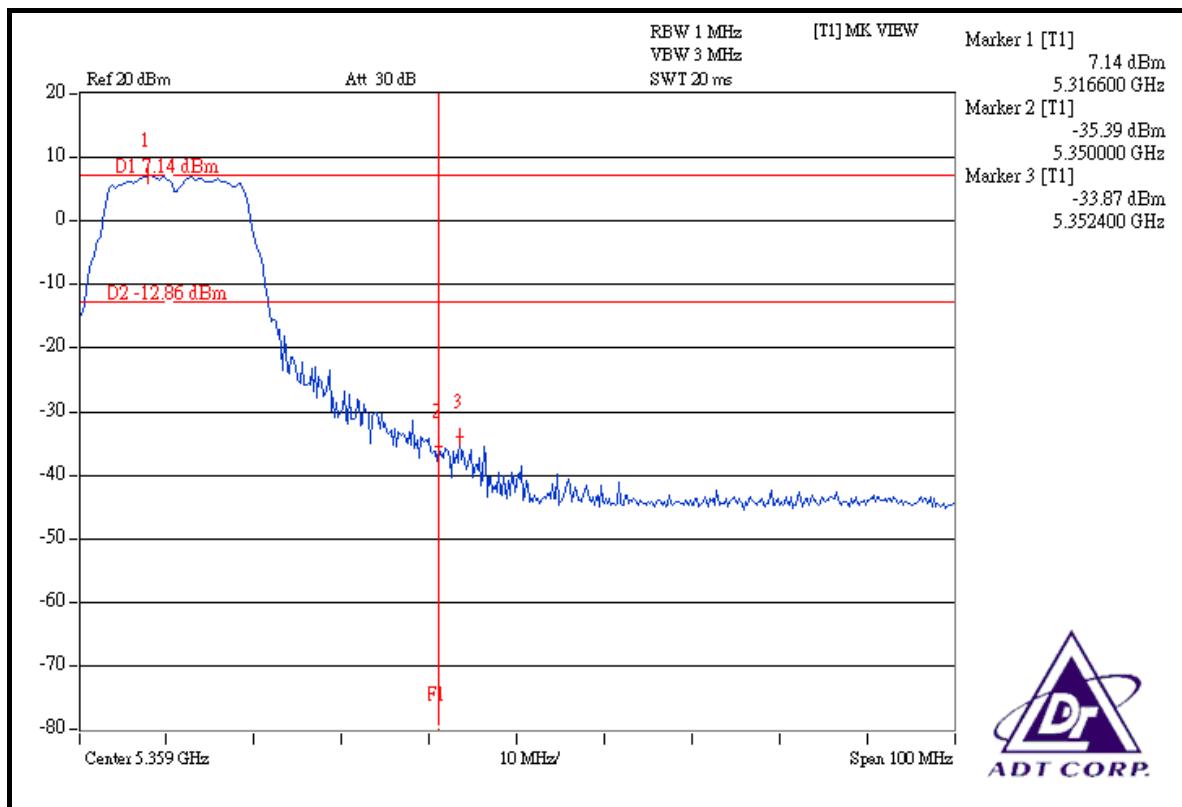
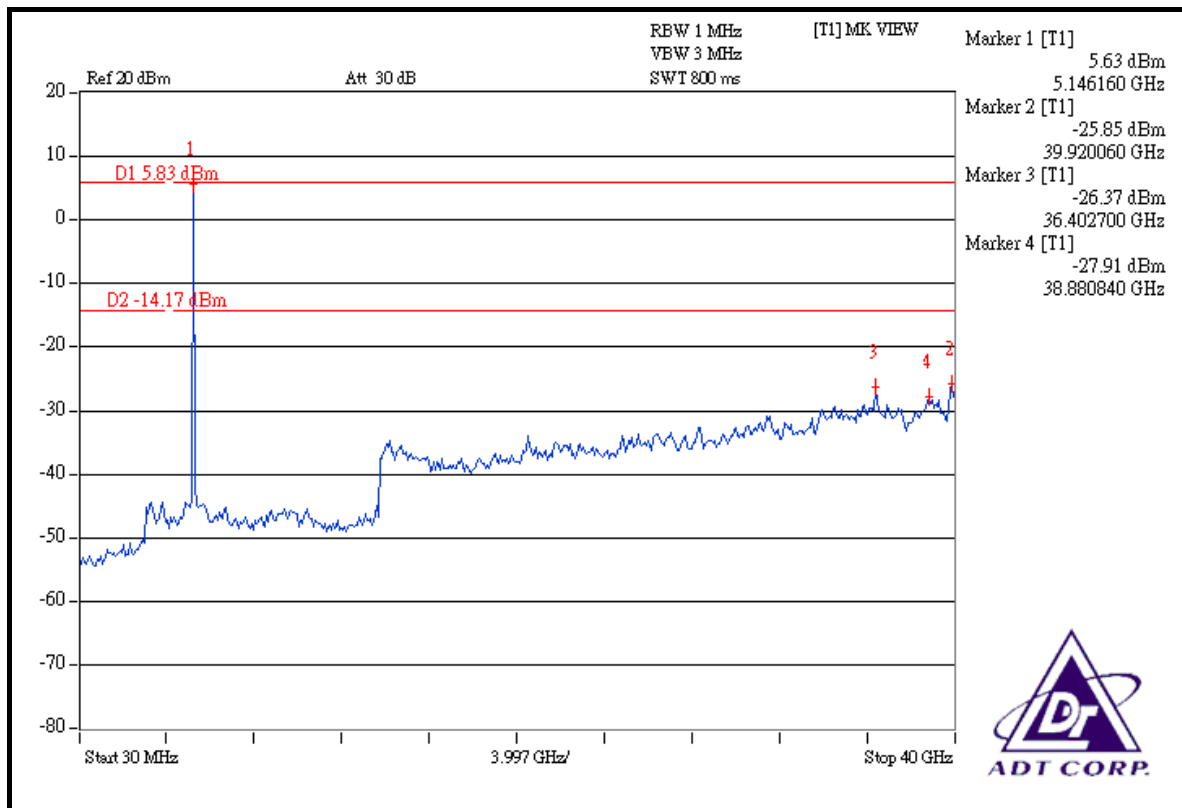

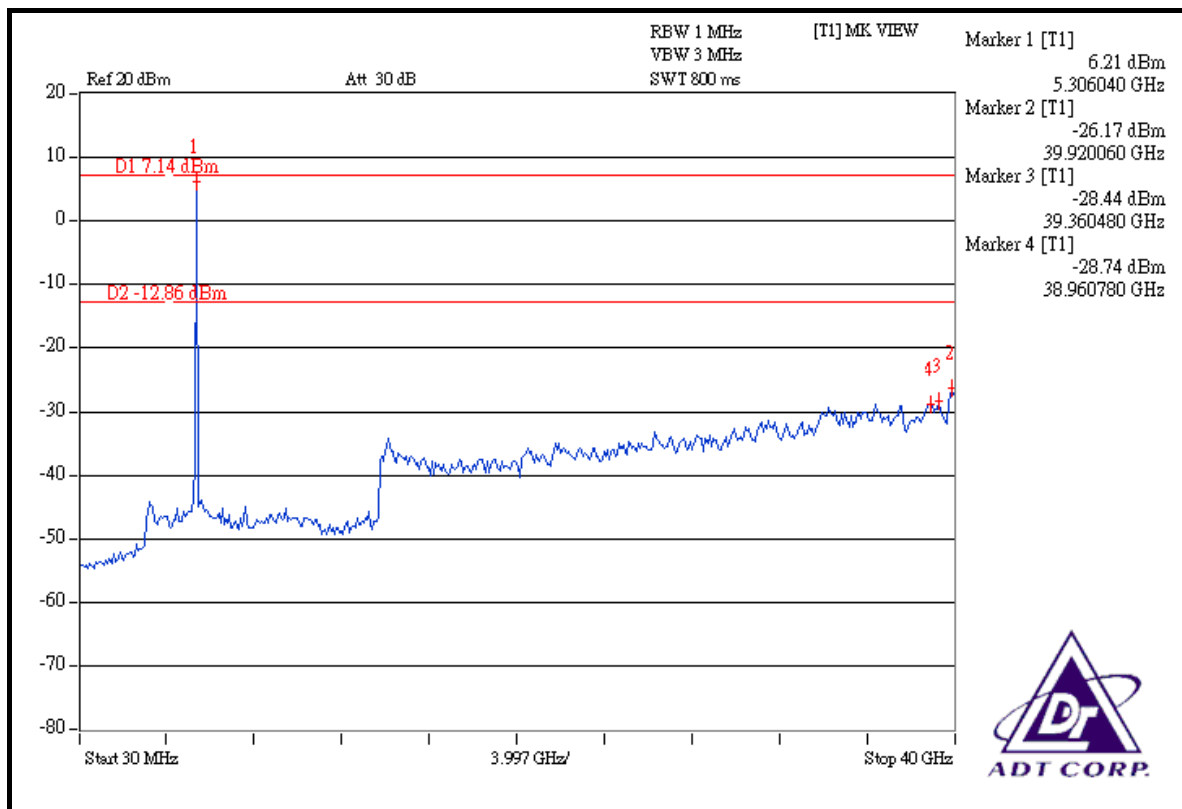
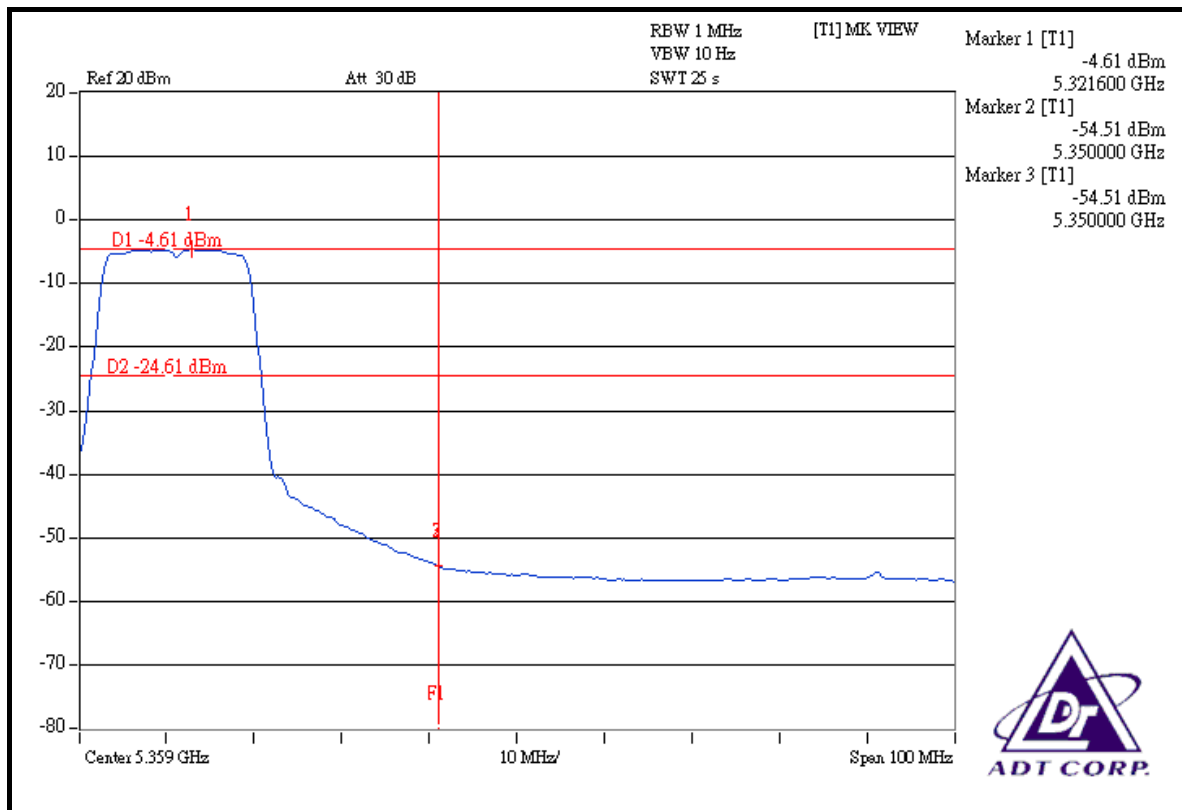

FOR 5470-5725MHz BAND: 802.11a OFDM MODULATION:

Channel 1 (5500MHz)

The band edge emission plot (5.470GHz) on the next page shows 44.12dBc between carrier maximum power and local maximum emission out of band emission. The emission of carrier strength list in the test result of channel 1 is 101.20dBuV/m (Peak), so the maximum field strength out of band emission is $101.20 - 44.12 = 57.08\text{dBuV/m}$ which is under 88.3dBuV/m limit.

The band edge emission plot (5.470GHz) on the next page shows 49.33dBc between carrier maximum power and local maximum emission in restrict band. The emission of carrier strength list in the test result of channel 1 is 90.62dBuV/m (Average), so the maximum field strength in restrict band is $90.62 - 49.33 = 41.29\text{dBuV/m}$ which is under 68.3dBuV/m limit.

The band edge emission plot (5.460GHz) on the next page shows 47.43dBc between carrier maximum power and local maximum emission in restrict band. The emission of carrier strength list in the test result of channel 1 is 101.20dBuV/m (Peak), so the maximum field strength in restrict band is $101.20 - 47.43 = 53.77\text{dBuV/m}$ which is under 74dBuV/m limit.

The band edge emission plot (5.460GHz) on the next page shows 51.41dBc between carrier maximum power and local maximum emission in restrict band. The emission of carrier strength list in the test result of channel 1 is 90.62dBuV/m (Average), so the maximum field strength in restrict band is $90.62 - 51.41 = 39.21\text{dBuV/m}$ which is under 54dBuV/m limit.

Channel 11 (5700MHz)

The band edge emission plot on the next second page shows 37.51dBc between carrier maximum power and local maximum emission in restrict band. The emission of carrier strength list in the test result of channel 11 is 98.96dBuV/m (Peak), so the maximum field strength in restrict band is $98.96 - 37.51 = 61.45\text{dBuV/m}$ which is under 88.3dBuV/m limit.

The band edge emission plot on the next third page shows 48.30dBc between carrier maximum power and local maximum emission in restrict band. The emission of carrier strength list in the test result of channel 11 is 88.57dBuV/m (Average), so the maximum field strength in restrict band is $88.57 - 48.30 = 40.27\text{dBuV/m}$ which is under 68.3dBuV/m limit.

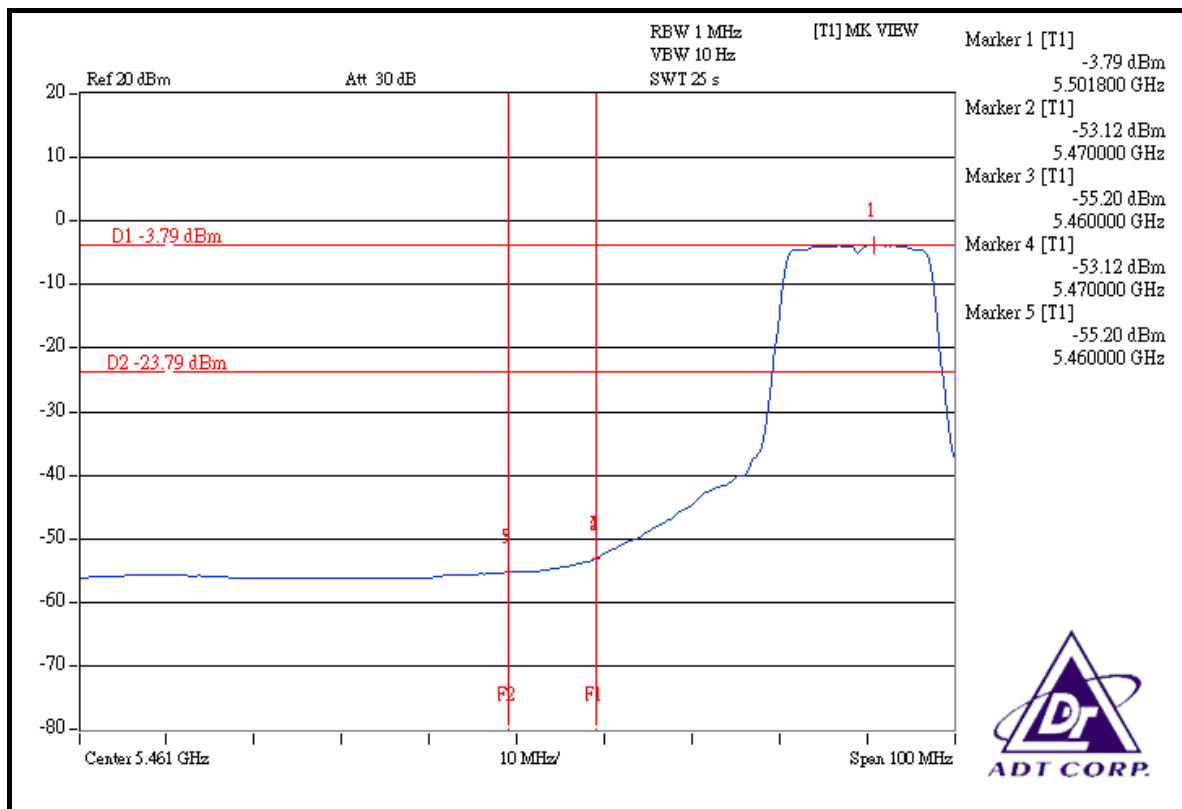
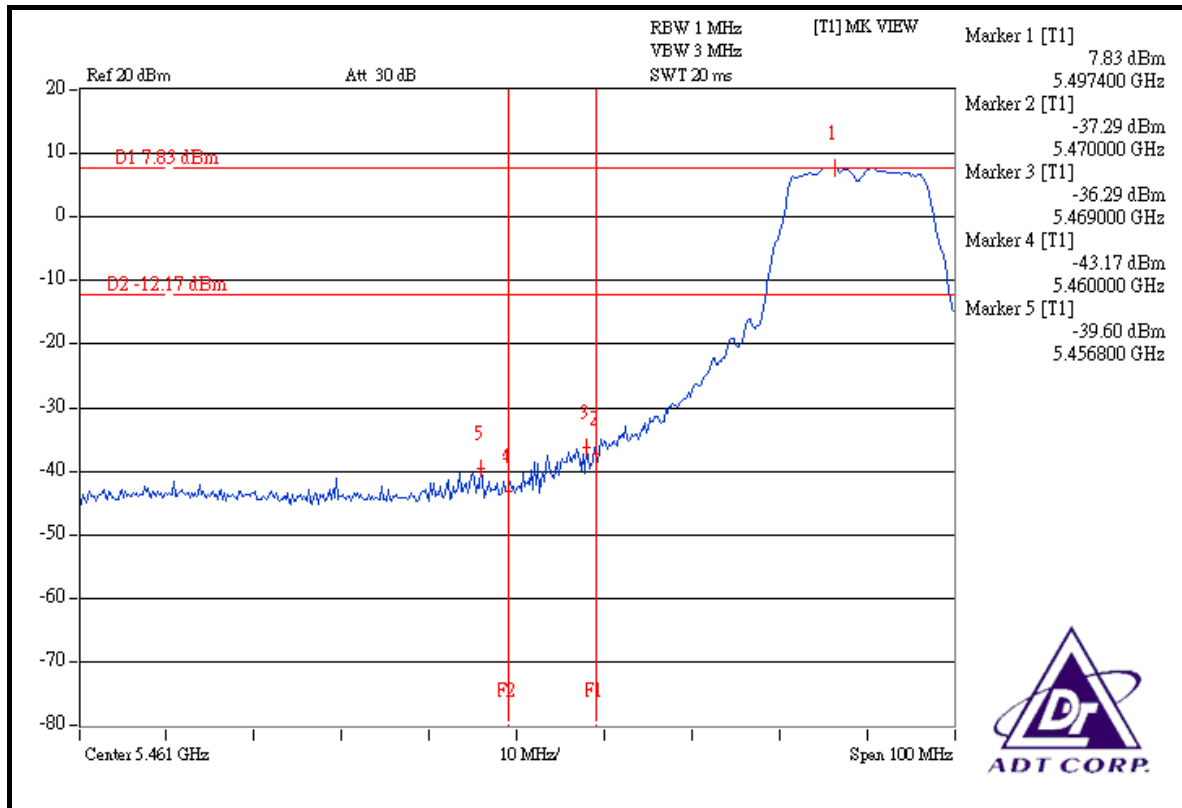

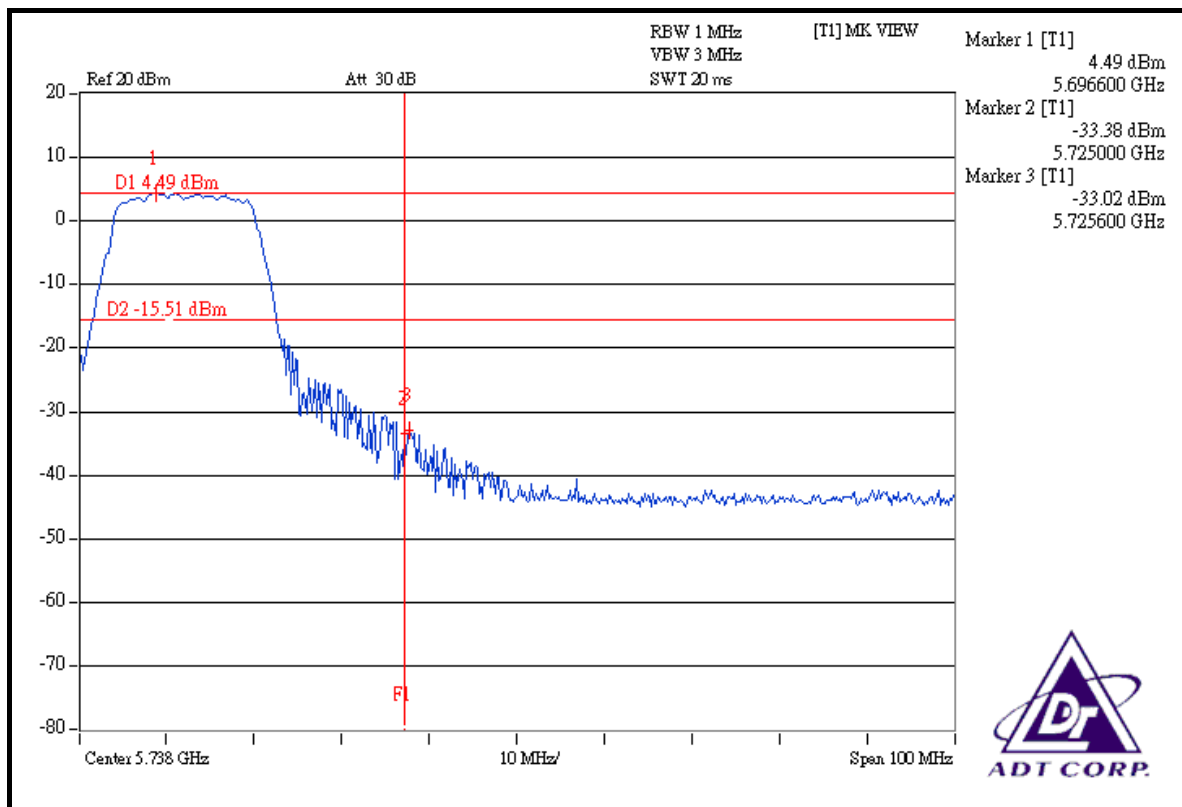
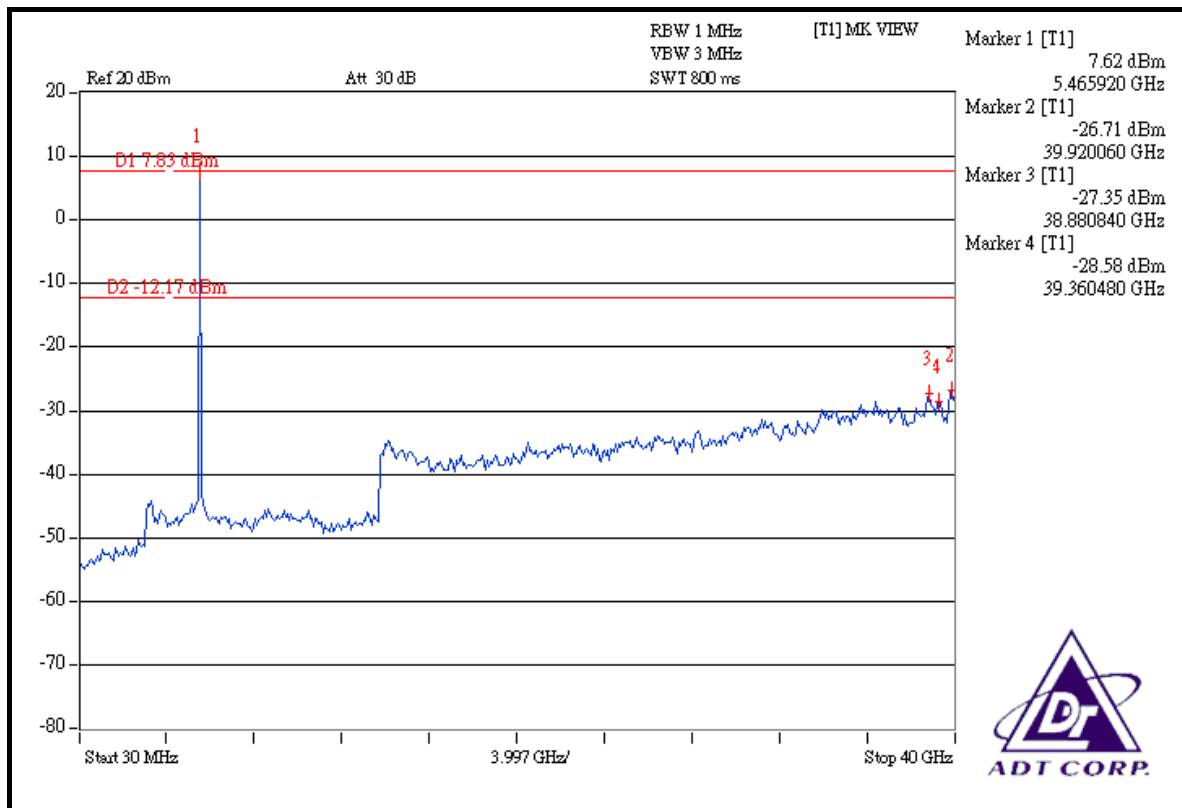

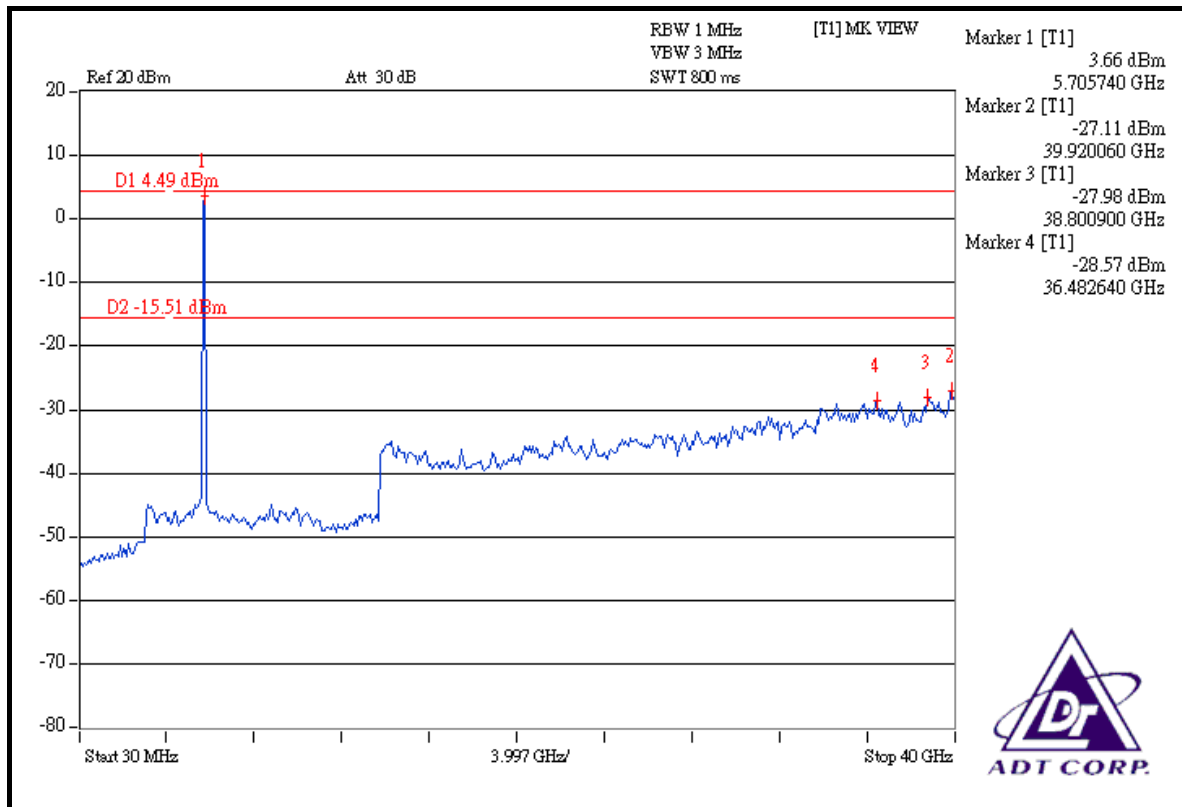
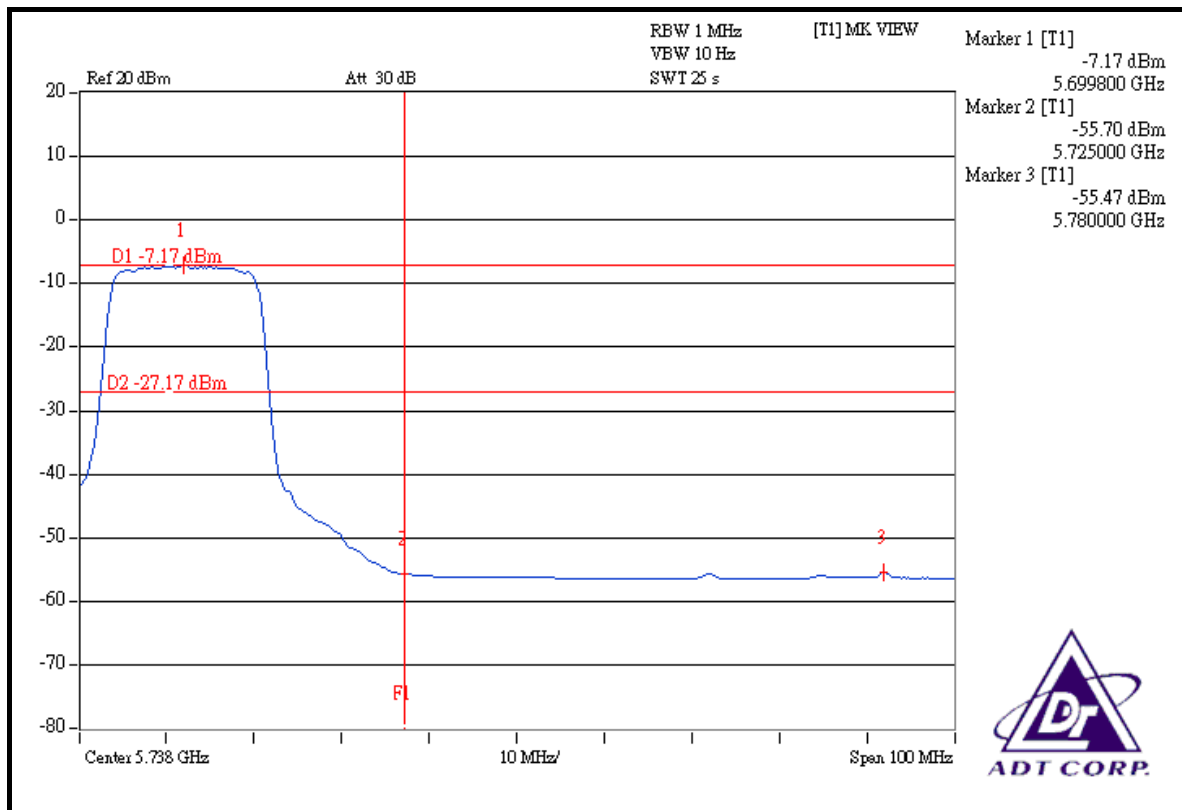



4.8 ANTENNA REQUIREMENT

4.8.1 STANDARD APPLICABLE

For intentional device, according to FCC 47 CFR Section 15.203, an intentional radiator shall be designed to ensure that no antenna other than that furnished by the responsible party shall be used with the device.

And according to FCC 47 CFR Section 15.407(a), if transmitting antennas of directional gain greater than 6dBi are used, the power shall be reduced by the amount in dB that the directional gain of the antenna exceeds 6dBi.

4.8.2 ANTENNA CONNECTED CONSTRUCTION

The antenna used in this product is Inverted F antenna and Planar inverted antenna without antenna connector. The maximum gain of the antenna is 3.5dBi.



5. PHOTOGRAPHS OF THE TEST CONFIGURATION

Please refer to the attached file (Test Setup Photo).



6. INFORMATION ON THE TESTING LABORATORIES

We, ADT Corp., were founded in 1988 to provide our best service in EMC, Radio, Telecom and Safety consultation. Our laboratories are accredited and approved by the following approval agencies according to ISO/IEC 17025.

USA	FCC, UL, A2LA
Germany	TUV Rheinland
Japan	VCCI
Norway	NEMKO
Canada	INDUSTRY CANADA, CSA
R.O.C.	TAF, BSMI, NCC
Netherlands	Telefication
Singapore	GOST-ASIA(MOU)
Russia	CERTIS(MOU)

Copies of accreditation certificates of our laboratories obtained from approval agencies can be downloaded from our web site:
www.adt.com.tw/index.5/phtml. If you have any comments, please feel free to contact us at the following:

Linko EMC/RF Lab:
Tel: 886-2-26052180
Fax: 886-2-26051924

Hsin Chu EMC/RF Lab:
Tel: 886-3-5935343
Fax: 886-3-5935342

Hwa Ya EMC/RF/Safety Telecom Lab:
Tel: 886-3-3183232
Fax: 886-3-3185050

Web Site: www.adt.com.tw

The address and road map of all our labs can be found in our web site also.



7. APPENDIX A - MODIFICATIONS RECORDERS FOR ENGINEERING CHANGES TO THE EUT BY THE LAB

No any modifications are made to the EUT by the lab during the test.