



DFS TEST REPORT

REPORT NO.: RF950803L01A

MODEL NO.: MC7095

RECEIVED: Sep. 06, 2006

TESTED: Mar. 16, 2007

ISSUED: Mar. 19, 2007

APPLICANT: Symbol Technologies, Inc.

ADDRESS: One Symbol Plaza Holtsville, NY United States 11742-1300

ISSUED BY: Advance Data Technology Corporation

LAB ADDRESS: No. 47, 14th Ling, Chia Pau Tsuen, Lin Kou Hsiang 244, Taipei Hsien, Taiwan, R.O.C.

TEST LOCATION: No. 19, Hwa Ya 2nd Rd., Wen Hwa Tsuen, Kwei Shan Hsiang, Taoyuan Hsien 333, Taiwan, R.O.C.

This test report consists of 17 pages in total. It may be duplicated completely for legal use with the approval of the applicant. It should not be reproduced except in full, without the written approval of our laboratory. The client should not use it to claim product endorsement by CNLA, A2LA or any government agencies. The test results in the report only apply to the tested sample.





Table of Contents

1.	CERTIFICATION	3
2.	TEST RESULTS	4
2.1	DYNAMIC FREQUENCY SELECTION	4
2.1.1	OPERATING FREQUENCY OF U-NII DEVICE	5
2.1.2	TEST LIMITS AND RADAR SIGNAL PARAMETERS	5
2.1.3	TEST INSTRUMENTS	8
2.1.4	DESCRIPTION OF SUPPORT UNITS	8
2.1.5	SOFTWARE AND FIRMWARE.....	8
2.1.6	DESCRIPTION OF AVAILABLE ANTENNAS	8
2.1.7	MAXIMUM AND MINIMUM CONDUCTED POWER	9
2.1.8	MAXIMUM AND MINIMUM E.I.R.P. POWER	9
2.1.9	TEST PROCEDURE	10
2.1.10	DEVIATION FROM TEST STANDARD	12
2.1.11	CONDUCTED TEST SETUP CONFIGURATION.....	12
2.1.12	LIST OF MEASUREMENTS.....	13
2.1.13	TEST RESULTS	14
3.	INFORMATION ON THE TESTING LABORATORIES	17



1. CERTIFICATION

PRODUCT: Enterprise Digital Assistant
MODEL: MC7095
BRAND: Symbol
APPLICANT: Symbol Technologies, Inc.
TESTED: Mar. 16, 2007
TEST SAMPLE: ENGINEERING SAMPLE
STANDARDS: **FCC Part 15, Subpart E (Section 15.407)**
FCC 06-96

The above equipment (model: MC7095) has been tested by **Advance Data Technology Corporation**, and found compliance with the requirement of the above standards. The test record, data evaluation & Equipment Under Test (EUT) configurations represented herein are true and accurate accounts of the measurements of the sample's EMC characteristics under the conditions specified in this report.

PREPARED BY : Rennie Wang , **DATE:** Mar. 19, 2007
Rennie Wang

TECHNICAL ACCEPTANCE : Dylan Chiou , **DATE:** Mar. 19, 2007
Responsible for RF Dylan Chiou

APPROVED BY : Gary Chang , **DATE:** Mar. 19, 2007
Gary Chang / Supervisor

2. TEST RESULTS

2.1 DYNAMIC FREQUENCY SELECTION

The manufacturer shall state whether the UUT is capable of operating as a Master and/or a Client. If the UUT is capable of operating in more than one operating mode then each operating mode shall be tested separately. See tables 1 and 2 for the applicability of DFS requirements for each of the operational modes.

Table 1: Applicability of DFS requirements prior to use a channel

Requirement	Operational Mode		
	Master	Client without radar detection	Client with radar detection
Non-Occupancy Period	✓	Not required	✓
DFS Detection Threshold	✓	Not required	✓
Channel Availability Check Time	✓	Not required	Not required
Uniform Spreading	✓	Not required	Not required
U-NII Detection Bandwidth	✓	Not required	✓

Table 2: Applicability of DFS requirements during normal operation.

Requirement	Operational Mode		
	Master	Client without radar detection	Client with radar detection
DFS Detection Threshold	✓	Not required	✓
Channel Closing Transmission Time	✓	✓	✓
Channel Move Time	✓	✓	✓
U-NII Detection Bandwidth	✓	Not required	✓

2.1.1 OPERATING FREQUENCY OF U-NII DEVICE

Table 3: Operating frequency range of UUT.

Operational Mode	Operating Frequency Range	
	5250~5350MHz	5470~5725MHz
Master	Not Apply	Not Apply
Client without radar detection	✓	✓
Client with radar detection	Not Apply	Not Apply

2.1.2 TEST LIMITS AND RADAR SIGNAL PARAMETERS

DETECTION THRESHOLD VALUES

Table 4: DFS Detection Thresholds for Master Devices and Client Devices With Radar Detection.

Maximum Transmit Power	Value (See Notes 1 and 2)
≥ 200 milliwatt	-64 dBm
< 200 milliwatt	-62 dBm

Note 1: This is the level at the input of the receiver assuming a 0 dBi receive antenna.
 Note 2: Throughout these test procedures an additional 1 dB has been added to the amplitude of the test transmission waveforms to account for variations in measurement equipment. This will ensure that the test signal is at or above the detection threshold level to trigger a DFS response.



Table 5: DFS Response Requirement Values

Parameter	Value
Non-occupancy period	Minimum 30 minutes
Channel Availability Check Time	60 seconds
Channel Move Time	10 seconds See Note 1.
Channel Closing Transmission Time	200 milliseconds + an aggregate of 60 milliseconds over remaining 10 second period. See Notes 1 and 2.
U-NII Detection Bandwidth	Minimum 80% of the UNII 99% transmission power bandwidth. See Note 3.

Note 1: The instant that the Channel Move Time and the Channel Closing Transmission Time begins is as follows:

- For the Short Pulse Radar Test Signals this instant is the end of the Burst.
- For the Frequency Hopping radar Test Signal, this instant is the end of the last radar Burst generated.
- For the Long Pulse Radar Test Signal this instant is the end of the 12 second period defining the Radar Waveform.

Note 2: The Channel Closing Transmission Time is comprised of 200 milliseconds starting at the beginning of the Channel Move Time plus any additional intermittent control signals required to facilitate a Channel move (an aggregate of 60 milliseconds) during the remainder of the 10 second period. The aggregate duration of control signals will not count quiet periods in between transmissions.

Note 3: During the U-NII Detection Bandwidth detection test, radar type 1 is used and for each frequency step the minimum percentage of detection is 90 percent. Measurements are performed with no data traffic.

PARAMETERS OF DFS TEST SIGNALS

Step intervals of 0.1 microsecond for Pulse Width, 1 microsecond for PRI, 1 MHz for chirp width and 1 for the number of pulses will be utilized for the random determination of specific test waveforms.

NOTE: No CODEC used for EUT to play MPEG file. So play WAV file for DFS test.

Table 6: Short Pulse Radar Test Waveforms.

Radar Type	Pulse Width (µsec)	PRI (µsec)	Number of Pulses	Minimum Percentage of Successful Detection	Minimum Number of Trials
1	1	1428	18	60%	30
2	1-5	150-230	23-29	60%	30
3	6-10	200-500	16-18	60%	30
4	11-20	200-500	12-16	60%	30
Aggregate (Radar Types 1-4)				80%	120

Table 7: Long Pulse Radar Test Waveform

Radar Type	Pulse Width (µsec)	Chirp Width (MHz)	PRI (µsec)	Number of Pulses per Burst	Number of Bursts	Minimum Percentage of Successful Detection	Minimum Number of Trials
5	50-100	5-20	1000-2000	1-3	8-20	80%	30

Table 8: Frequency Hopping Radar Test Waveform

Radar Type	Pulse Width (µsec)	PRI (µsec)	Pulses per Hop	Hopping Rate (kHz)	Hopping Sequence Length (msec)	Minimum Percentage of Successful Detection	Minimum Number of Trials
6	1	333	9	0.333	300	70%	30

2.1.3 TEST INSTRUMENTS

Table 9: Test instruments list.

DESCRIPTION & MANUFACTURER	MODEL NO.	BRAND	CALIBRATED UNTIL
R&S Spectrum analyzer	FSP40	R&S	Apr. 09, 2007
Signal generator	8645A	Agilent	May. 24, 2007
Oscilloscope	TDS 5104	Tektronix	Aug. 28. 2007

2.1.4 DESCRIPTION OF SUPPORT UNITS

Table 10: Support Unit information.

No.	Product	Brand	Model No.	ID
1	802.11a/b/g Access Point	Cisco	AIR-AP1242AG-A-K9	LDK102056

2.1.5 SOFTWARE AND FIRMWARE

Table 11: The software/firmware version for U-NII device.

No.	Product	Model No.	Software/Firmware Version
1	802.11a/b/g Access Point	AIR-AP1242AG-A-K9	C1240-K9W7-TAR.123-11.JA
2	Enterprise Digital Assistant	MC 7095	02.25.0003

2.1.6 DESCRIPTION OF AVAILABLE ANTENNAS

Table 12: Antenna list.

Antenna	Type	Operation Frequency Range	Max. Gain(dBi)
SD1000128	PIFA	5.1 ~ 5.9 GHz	2.5

2.1.7 MAXIMUM AND MINIMUM CONDUCTED POWER

Table 13: The measured conducted output power.

Frequency Band(MHZ)	MAX. Power		MIN. Power	
	Output Power(dBm)	Output Power(mW)	Output Power(dBm)	Output Power(mW)
5250~5350MHz	16.00	39.810	12.00	15.849
5470~5725MHz	14.04	25.350	12.00	15.849

2.1.8 MAXIMUM AND MINIMUM E.I.R.P. POWER

Table 14: The E.I.R.P output power list.

Frequency Band(MHZ)	MAX. Power		MIN. Power	
	Output Power(dBm)	Output Power(mW)	Output Power(dBm)	Output Power(mW)
5250~5350MHz	18.50	70.790	14.50	28.184
5470~5725MHz	16.29	42.560	14.50	28.184

2.1.9 TEST PROCEDURE

ADT DFS Measurement System:

A complete ADT DFS Measurement System consists of two subsystems: (1) the Radar Signal Generating Subsystem and (2) the Traffic Monitoring Subsystem. The control PC is necessary for generating the Radar waveforms in Table 6, 7 and 8. The traffic monitoring subsystem is specified to the type of unit under test (UUT).

Conducted setup configuration of ADT DFS Measurement System

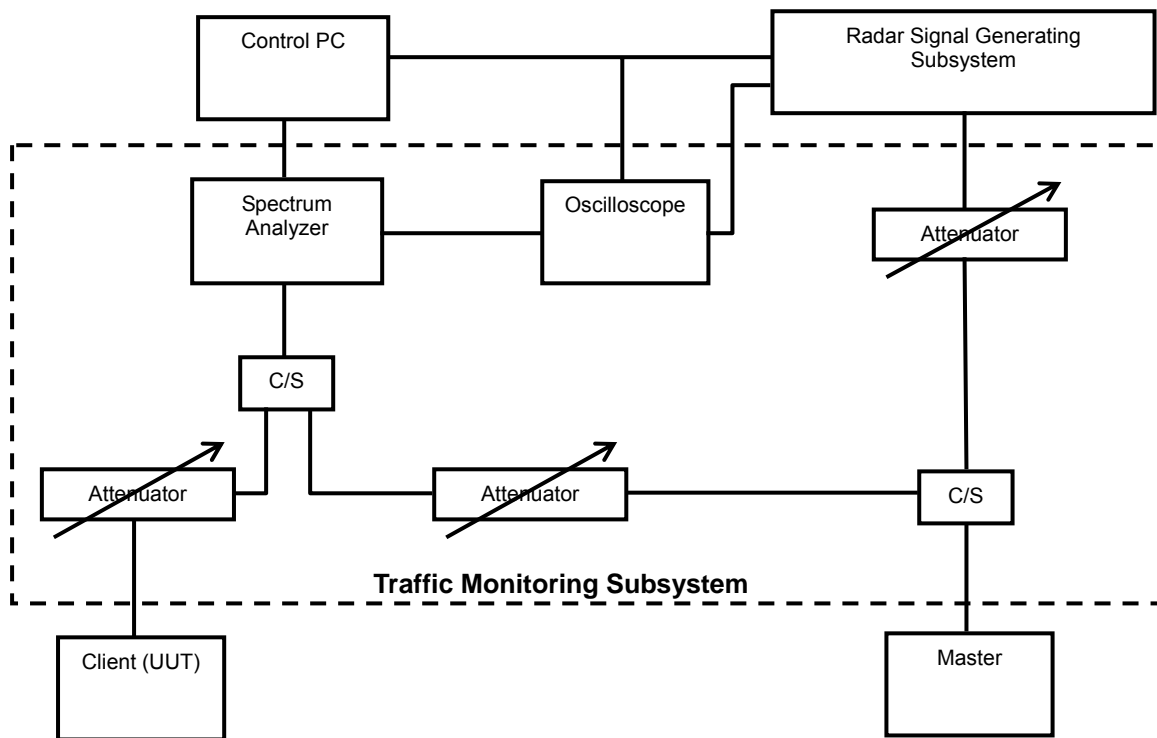

The test transmission will always be from the Master Device to the Client Device. While the Client device is set up to associate with the Master device and play the WAV file (5_GHz_Audio_Test_file) from Master device, the designated WAV test file and instructions are located at: <http://ntiacsd.ntia.doc.gov/dfs/>.

Calibration of DFS Detection Threshold Level:

The measured channel is 5320MHz. The radar signal was the same as transmitted channels, and injected into the antenna port of AP (master), measured the channel closing transmission time and channel move time. The Required detection threshold is $-58\text{dBm} (= -62 + 1 + 3)\text{dBm}$. The calibrated conducted detection threshold level is set to -59dBm . The tested level is lower than required level hence it provides margin to the limit.

NOTE: antenna gain for the AP is 3dBi.

Conducted setup configuration of Calibration of DFS Detection Threshold Level

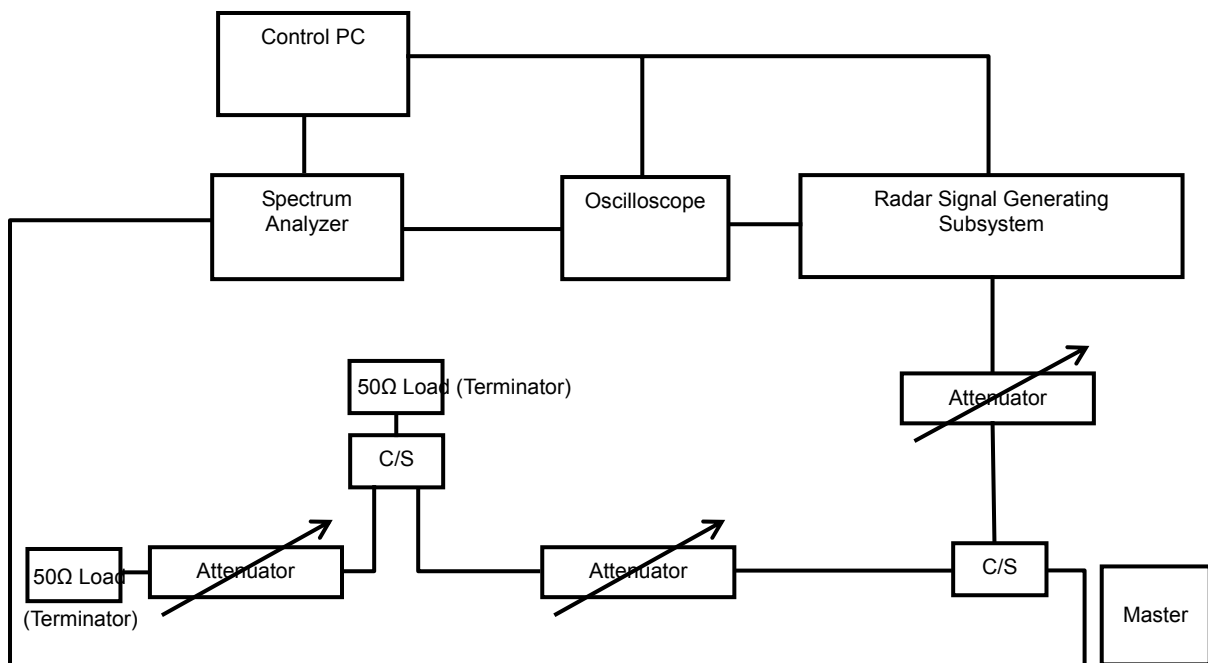

2.1.10 DEVIATION FROM TEST STANDARD

No deviation.

2.1.11 CONDUCTED TEST SETUP CONFIGURATION

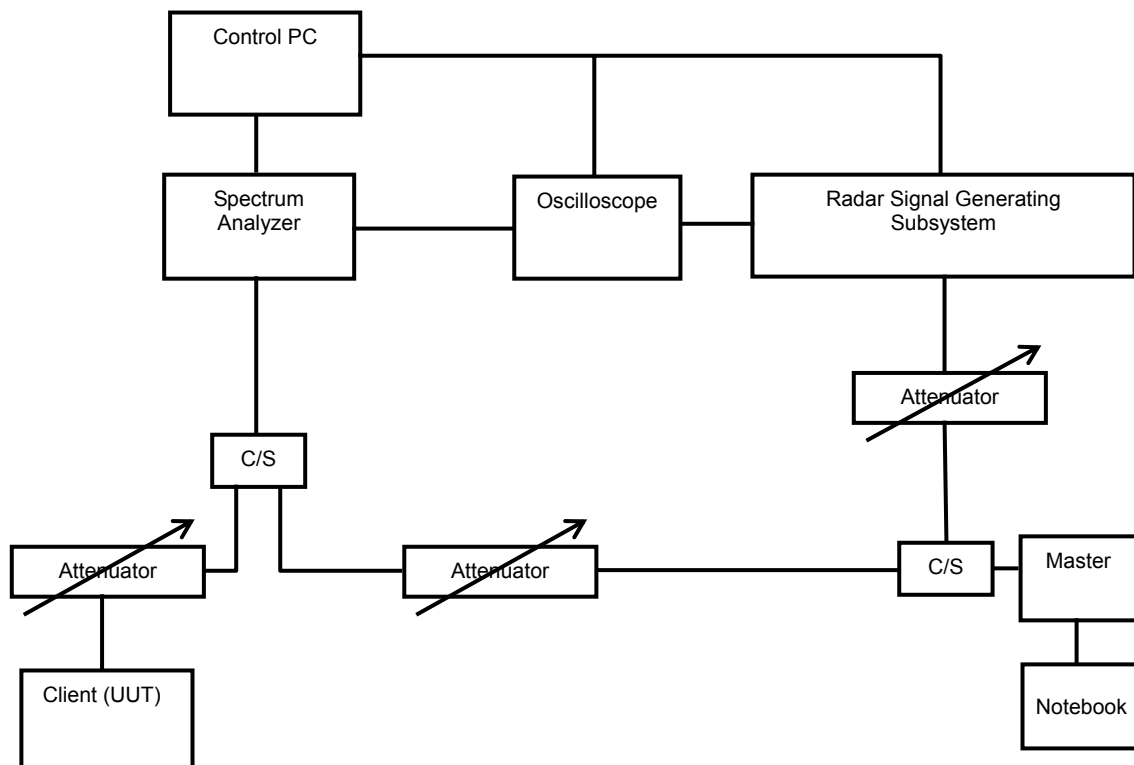

The UUT is a U-NII Device operating in Client mode without Radar Detection function. The radar test signals are injected into the Master Device.

2.1.12 LIST OF MEASUREMENTS

The UUT (MC7095) is capable of operating as a Client (without radar detection).

Clause	Test Parameter	Remarks	Pass/Fail
15.407	Channel Availability Check Time	Not Required	NA
15.407	In-Service Monitoring	Not Required	NA
15.407	Channel Move Time	Applicable	Pass
15.407	Channel Closing Transmission Time	Applicable	Pass
15.407	Non- Occupancy Period	Not Required	NA
15.407	Uniform Spreading	Not Required	NA

2.1.13 TEST RESULTS

DETECTION THRESHOLD VALUES INJECTED INTO AP

For a detection threshold level of -62dBm and the AP antenna gain is 3dBi . Then the radar Burst signal level to the AP connector is -59dBm .

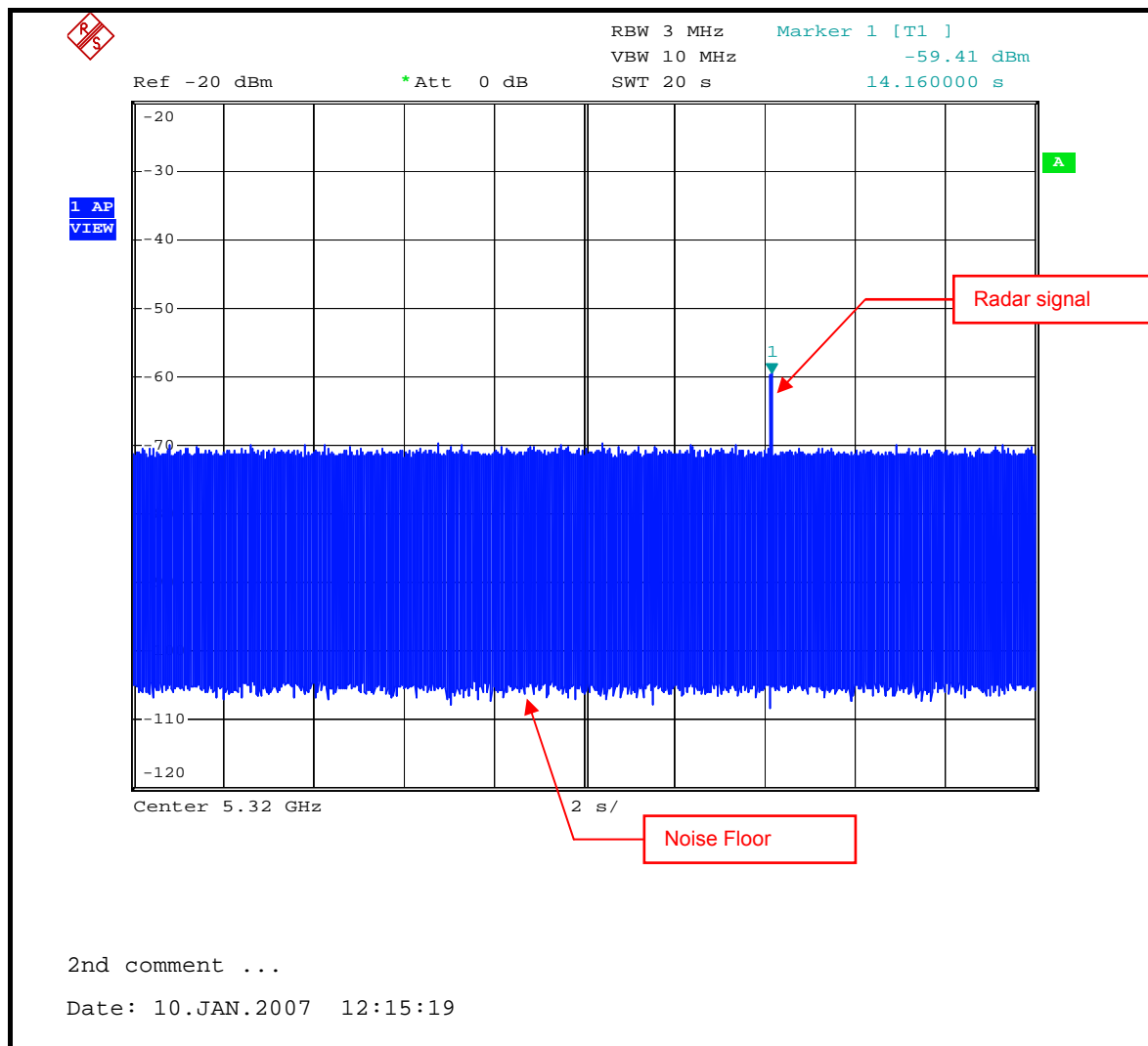

Radar Signal 1

Channel Closing Transmission and Channel Move Time

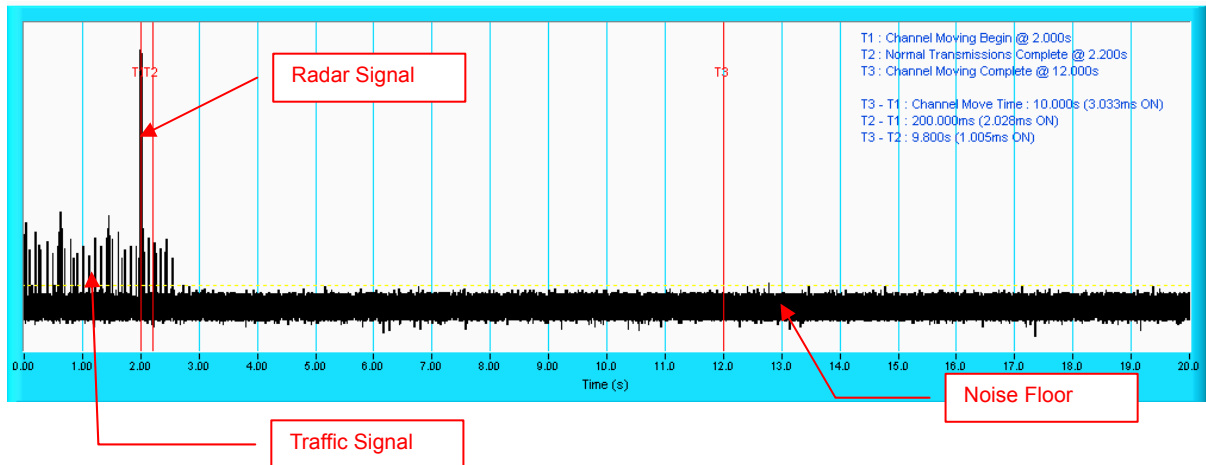

Radar signal 1

NOTE: T1 denotes the start of Channel Move Time upon the end of the last Radar burst. T2 denotes the data transmission time of 200ms from T1. T3 denotes the 10 second from T1 to observe the aggregate duration of transmissions.



Type 1 Radar Statistical Performances				
Trial #	Pulses per Burst	Pulse Width (s)	PRI (s)	Detection
1	18	1.0u	1.428m	Yes
2	18	1.0u	1.428m	No
3	18	1.0u	1.428m	Yes
4	18	1.0u	1.428m	No
5	18	1.0u	1.428m	Yes
6	18	1.0u	1.428m	Yes
7	18	1.0u	1.428m	Yes
8	18	1.0u	1.428m	Yes
9	18	1.0u	1.428m	Yes
10	18	1.0u	1.428m	Yes
11	18	1.0u	1.428m	Yes
12	18	1.0u	1.428m	No
13	18	1.0u	1.428m	Yes
14	18	1.0u	1.428m	Yes
15	18	1.0u	1.428m	Yes
16	18	1.0u	1.428m	Yes
17	18	1.0u	1.428m	Yes
18	18	1.0u	1.428m	Yes
19	18	1.0u	1.428m	Yes
20	18	1.0u	1.428m	Yes
21	18	1.0u	1.428m	Yes
22	18	1.0u	1.428m	Yes
23	18	1.0u	1.428m	Yes
24	18	1.0u	1.428m	Yes
25	18	1.0u	1.428m	Yes
26	18	1.0u	1.428m	Yes
27	18	1.0u	1.428m	Yes
28	18	1.0u	1.428m	Yes
29	18	1.0u	1.428m	Yes
30	18	1.0u	1.428m	No
Detection Rate: 86.7 %				



3. INFORMATION ON THE TESTING LABORATORIES

We, ADT Corp., were founded in 1988 to provide our best service in EMC, Radio, Telecom and Safety consultation. Our laboratories are accredited and approved by the following approval agencies according to ISO/IEC 17025.

USA	FCC, UL, A2LA
Germany	TUV Rheinland
Japan	VCCI
Norway	NEMKO
Canada	INDUSTRY CANADA , CSA
R.O.C.	CNLA, BSMI, NCC
Netherlands	Telefication
Singapore	PSB , GOST-ASIA(MOU)
Russia	CERTIS(MOU)

Copies of accreditation certificates of our laboratories obtained from approval agencies can be downloaded from our web site:

www.adt.com.tw/index.5/phtml. If you have any comments, please feel free to contact us at the following:

Linko EMC/RF Lab:

Tel: 886-2-26052180
Fax: 886-2-26051924

Hsin Chu EMC/RF Lab:

Tel: 886-3-5935343
Fax: 886-3-5935342

Hwa Ya EMC/RF/Safety Telecom Lab:

Tel: 886-3-3183232
Fax: 886-3-3185050

Web Site: www.adt.com.tw

The address and road map of all our labs can be found in our web site also.