



Specific Absorption Rate (SAR) Test Report
for
Symbol Technologies Inc
on the
EDA (Enterprise Digital Assistant)

Report Number : FA802811A
Trade Name : Symbol
Model Name : MC5574
FCC ID : H9PMC5574A
Date of Testing : Nov. 09, 2008 ~ Jan. 15, 2009
Date of Report : Jan. 15, 2009

- The test results refer exclusively to the tested model/sample only.
- Without written approval of SPORTON INTERNATIONAL INC., the test report shall not be reproduced except in full.
- Report Version: Rev. 02

SPORTON INTERNATIONAL INC.

No. 52, Hwa Ya 1st Rd., Hwa Ya Technology Park, Kwei-Shan Hsiang, Tao Yuan Hsien, Taiwan, R.O.C.



Table of Contents

- 1. **Statement of Compliance**3
- 2. **Administration Data**4
 - 2.1 Testing Laboratory4
 - 2.2 Applicant4
 - 2.3 Manufacturer4
 - 2.4 Application Details4
- 3. **General Information**5
 - 3.1 Description of Device Under Test (DUT)5
 - 3.2 Basic Description of Accessories6
 - 3.3 Product Photos6
 - 3.4 Applied Standards6
 - 3.5 Device Category and SAR Limits7
 - 3.6 Test Conditions7
 - 3.6.1 Ambient Condition7
 - 3.6.2 Test Configuration7
- 4. **Specific Absorption Rate (SAR)**8
 - 4.1 Introduction8
 - 4.2 SAR Definition8
- 5. **SAR Measurement Setup**9
 - 5.1 DASYS E-Field Probe System10
 - 5.1.1 ET3DV6 E-Field Probe Specification10
 - 5.1.2 ET3DV6 E-Field Probe Calibration10
 - 5.2 DATA Acquisition Electronics (DAE)11
 - 5.3 Robot11
 - 5.4 Measurement Server11
 - 5.5 SAM Twin Phantom12
 - 5.6 Device Holder for SAM Twin Phantom13
 - 5.7 Data Storage and Evaluation14
 - 5.7.1 Data Storage14
 - 5.7.2 Data Evaluation14
 - 5.8 Test Equipment List16
- 6. **Tissue Simulating Liquids**17
- 7. **Uncertainty Assessment**19
- 8. **SAR Measurement Evaluation**21
 - 8.1 Purpose of System Performance check21
 - 8.2 System Setup21
 - 8.3 Validation Results23
- 9. **Description for DUT Testing Position**24
- 10. **Measurement Procedures**26
 - 10.1 Spatial Peak SAR Evaluation26
 - 10.2 Scan Procedures27
 - 10.3 SAR Averaged Methods27
- 11. **SAR Test Results**28
 - 11.1 Conducted Power28
 - 11.2 Test Records for Head SAR Test29
 - 11.3 Test Records for Body SAR Test with 1.5cm Gap30
 - 11.4 Test Records for Body SAR Test with Holster31
 - 11.5 Volume Scan SAR32
- 12. **References**33
- Appendix A - System Performance Check Data**
- Appendix B - SAR Measurement Data**
- Appendix C - Calibration Data**
- Appendix D - Product Photos**
- Appendix E - Test Setup Photos**



1. Statement of Compliance

The Specific Absorption Rate (SAR) maximum results found during testing for the **Symbol Technologies Inc EDA (Enterprise Digital Assistant) Symbol MC5574** are as follows (with expanded uncertainty 21.9%):

<Standalone SAR>

SAR Position	GSM850 (W/kg)	GSM1900 (W/kg)
Head	1.33	0.567
Body (with 1.5cm Gap)	0.387	0.230
Body (with Holster 1, P/N: 11-57530-02)	0.116	0.484
Body (with Holster 2, P/N: 21-67292-01R)	0.197	0.349
Body (with Holster 3, P/N: SG-MC5521110-01R)	0.351	0.183

<Simultaneous Transmission SAR>

Position	Mode	Channel	Multi Band SAR _{1g} (W/kg)
Right Cheek	GSM850	251	1.45
	802.11g	6	

They are in compliance with Specific Absorption Rate (SAR) for general population/uncontrolled exposure limits specified in FCC 47 CFR part 2 (2.1093) and ANSI/IEEE C95.1-1999 and had been tested in accordance with the measurement methods and procedures specified in IEEE P1528-2003, and OET Bulletin 65 Supplement C (Edition 01-01).

Approved by

Roy Wu
Manager



2. Administration Data

2.1 Testing Laboratory

Company Name : Sporton International Inc.
Address : No.52, Hwa-Ya 1st RD., Hwa Ya Technology Park, Kwei-Shan Hsiang,
TaoYuan Hsien, Taiwan, R.O.C.
Test Site : SAR02-HY
Telephone Number : 886-3-327-3456
Fax Number : 886-3-328-4978

2.2 Applicant

Company Name : Symbol Technologies Inc
Address : One Symbol Plaza Holtsville, NY 11742-1300 USA

2.3 Manufacturer

Company Name : Symbol Technologies Inc
Address : One Symbol Plaza Holtsville, NY 11742-1300 USA

2.4 Application Details

Date of reception of application: Oct. 28, 2008
Start of test : Nov. 09, 2008
End of test : Jan. 15, 2009



3. General Information

3.1 Description of Device Under Test (DUT)

Product Feature & Specification	
DUT Type :	EDA (Enterprise Digital Assistant)
Trade Name :	Symbol
Model Name :	MC5574
Sample 1 :	1D Scanner + Numeric Keypad
Sample 2 :	2D Scanner + Qwerty Keypad
FCC ID :	H9PMC5574A
Tx Frequency :	GSM850 : 824 MHz ~ 849 MHz GSM1900 : 1850 MHz ~ 1910 MHz
Rx Frequency :	GSM850 : 869 MHz ~ 894 MHz GSM1900 : 1930 MHz ~ 1990 MHz
Maximum Output Power to Antenna :	GSM850 : 33.03 dBm GSM1900 : 29.57 dBm
Antenna Type :	Fixed Internal Antenna
HW Version :	DV
SW Version :	BSP25
Type of Modulation :	GSM / GPRS : GMSK EDGE : 8PSK
DUT Stage :	Identical Prototype

3.2 Basic Description of Accessories

AC Adapter	Brand Name	Motorola
	Model Name	EADP-16BB A
	Power Rating	I/P: 100-240Vac, 50-60Hz, 0.4A; O/P: 5.4Vdc, 3A
	DC Power Cord Type	1.94 meter with shielded cable without ferrite core
Power Cable	AC Power Cord Type	1.82 meter without shielded cable without ferrite core
Battery 1	Brand Name	Motorola
	Model Name	82-107172-01
	Power Rating	3.7Vdc, 2400mAh
	Type	Li-ion
Battery 2	Brand Name	Motorola
	Model Name	82-111094-01
	Power Rating	3.7Vdc, 3600mAh
	Type	Li-ion
USB Cable	Brand Name	Motorola
	Part Number	25-108022-01R
	Signal Line Type	1.62 meter shielded cable with ferrite core
Holster 1	Brand Name	Symbol
	Part Number	11-57530-02
Holster 2	Brand Name	Symbol
	Part Number	21-67292-01R
Holster 3	Brand Name	Symbol
	Part Number	SG-MC5521110-01R

Remark: Above DUT's information was declared by manufacturer. Please refer to the specifications of manufacturer or User's Manual for more detailed features description.

3.3 Product Photos

Refer to Appendix D.

3.4 Applied Standards

The Specific Absorption Rate (SAR) testing specification, method and procedure for this EDA (Enterprise Digital Assistant) is in accordance with the following standards:

- 47 CFR Part 2 (2.1093)
- IEEE C95.1-1999
- IEEE C95.3-2002
- IEEE P1528-2003
- OET Bulletin 65 Supplement C (Edition 01-01)
- KDB 648474 D01 v01r05



3.5 Device Category and SAR Limits

This device belongs to portable device category because its radiating structure is allowed to be used within 20 centimeters of the body of the user. Limit for General Population/Uncontrolled exposure should be applied for this device, it is 1.6 W/kg as averaged over any 1 gram of tissue.

3.6 Test Conditions

3.6.1 Ambient Condition

Ambient Temperature	20-24
Humidity	<60 %

3.6.2 Test Configuration

The device was controlled by using a base station emulator R&S CMU200. Communication between the device and the emulator was established by air link. The distance between the DUT and the antenna of the emulator is larger than 50 cm and the output power radiated from the emulator antenna is at least 30 dB smaller than the output power of DUT. The DUT was set from the emulator to radiate maximum output power during all tests.

For head SAR testing, EUT is in GSM link mode and its crest factor is 8.3. For body SAR testing, EUT is in GPRS/EDGE link mode and its crest factor is 2, because EUT is GPRS/EDGE multi-slot class 12 device with 4 uplink slots.

Measurements were performed on the lowest, middle, and highest channel for each testing position. However, measurements were performed only on the middle channel if the SAR is below 3 dB of limit.

The SAR to peak location separation ratio of WWAN and WLAN is as below:

Summation SAR = 1.33(GSM850) + 0.06(802.11g) = 1.39 W/kg

Peak Location Spacing = 3.95 cm

SAR to Peak Location Spacing Ratio = 1.39 / 3.95 = 0.352

According KDB 648474, the SAR to peak location separation ratio is larger than 0.3, so the simultaneous transmission SAR evaluation is required.

4. Specific Absorption Rate (SAR)

4.1 Introduction

SAR is related to the rate at which energy is absorbed per unit mass in an object exposed to a radio field. The SAR distribution in a biological body is complicated and is usually carried out by experimental techniques or numerical modeling. The standard recommends limits for two tiers of groups, occupational/controlled and general population/uncontrolled, based on a person's awareness and ability to exercise control over his or her exposure. In general, occupational/controlled exposure limits are higher than the limits for general population/uncontrolled.

4.2 SAR Definition

The SAR definition is the time derivative (rate) of the incremental energy (dW) absorbed by (dissipated in) an incremental mass (dm) contained in a volume element (dv) of a given density (ρ). The equation description is as below:

$$\mathbf{SAR} = \frac{d}{dt} \left(\frac{dW}{dm} \right) = \frac{d}{dt} \left(\frac{dW}{\rho dv} \right)$$

SAR is expressed in units of Watts per kilogram (W/kg)

SAR measurement can be either related to the temperature elevation in tissue by

$$\mathbf{SAR} = C \frac{\delta T}{\delta t}$$

, where C is the specific heat capacity, δT is the temperature rise and δt the exposure duration,

or related to the electrical field in the tissue by

$$\mathbf{SAR} = \frac{\sigma |E|^2}{\rho}$$

, where σ is the conductivity of the tissue, ρ is the mass density of the tissue and E is the rms electrical field strength.

However for evaluating SAR of low power transmitter, electrical field measurement is typically applied.

5. SAR Measurement Setup

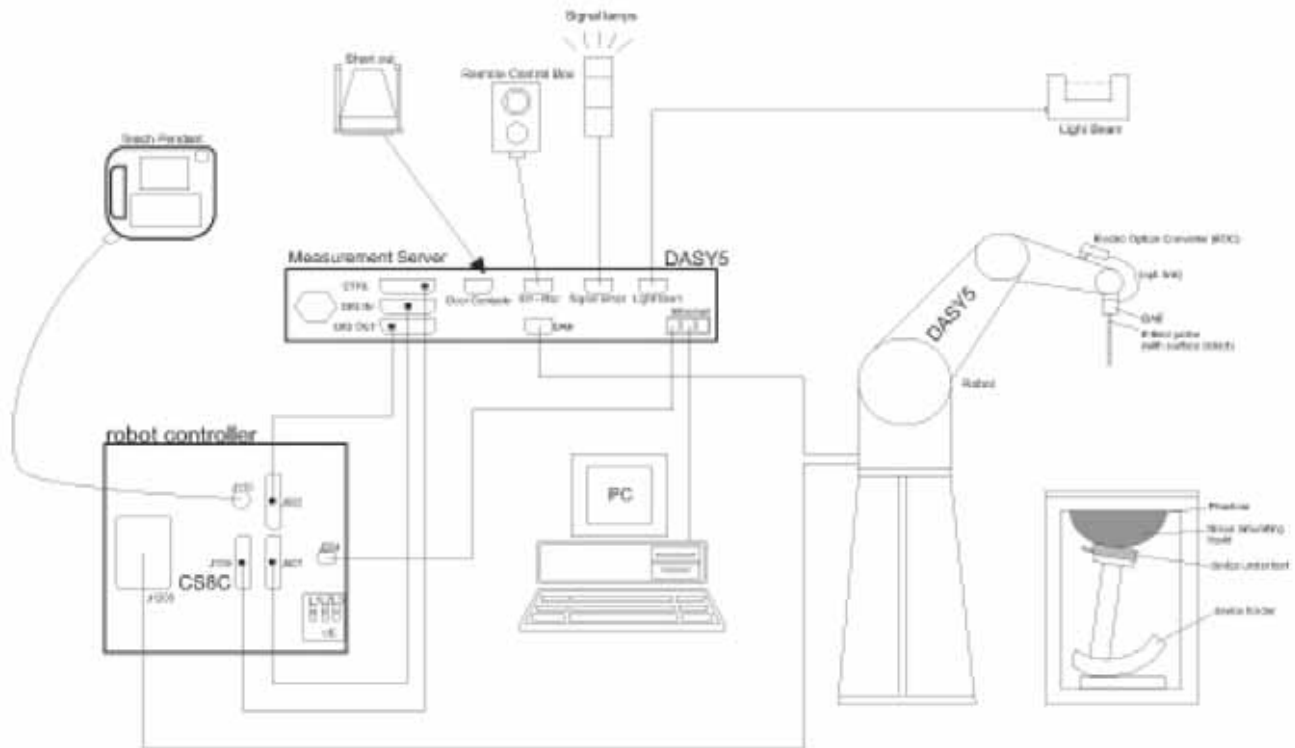

Fig. 5.1 DASY5 System

The DASY5 system for performance compliance tests is illustrated above graphically. This system consists of the following items:

- A standard high precision 6-axis robot with controller, a teach pendant and software
- A data acquisition electronic (DAE) attached to the robot arm extension
- A dosimetric probe equipped with an optical surface detector system
- The electro-optical converter (ECO) performs the conversion between optical and electrical signals
- A measurement server performs the time critical tasks such as signal filtering, control of the robot operation and fast movement interrupts.
- A probe alignment unit which improves the accuracy of the probe positioning
- A computer operating Windows XP
- DASY5 software
- Remove control with teach pendant and additional circuitry for robot safety such as warning lamps, etc.
- The SAM twin phantom
- A device holder
- Tissue simulating liquid
- Dipole for evaluating the proper functioning of the system

Some of the components are described in details in the following sub-sections.

5.1 DASY5 E-Field Probe System

The SAR measurement is conducted with the dosimetric probe ET3DV6 (manufactured by SPEAG). The probe is specially designed and calibrated for use in liquid with high permittivity. The dosimetric probe has special calibration in liquid at different frequency. This probe has a built in optical surface detection system to prevent from collision with phantom.

5.1.1 ET3DV6 E-Field Probe Specification

<ET3DV6>

Construction	Symmetrical design with triangular core Built-in optical fiber for surface detection system Built-in shielding against static charges PEEK enclosure material (resistant to organic solvents)
Frequency	10 MHz to 3 GHz
Directivity	± 0.2 dB in brain tissue (rotation around probe axis) ± 0.4 dB in brain tissue (rotation perpendicular to probe axis)
Dynamic Range	5 μ W/g to > 100mW/g; Linearity: ±0.2dB
Surface Detection	± 0.2 mm repeatability in air and clear liquids on reflecting surface
Dimensions	Overall length: 330mm Tip length: 16mm Body diameter: 12mm Tip diameter: 6.8mm Distance from probe tip to dipole centers: 2.7mm
Application	General dosimetry up to 3GHz Compliance tests for mobile phones and Wireless LAN Fast automatic scanning in arbitrary phantoms



Fig. 5.2 Probe Setup on Robot

5.1.2 ET3DV6 E-Field Probe Calibration

Each probe needs to be calibrated according to a dosimetric assessment procedure with accuracy better than ± 10%. The spherical isotropy shall be evaluated and within ± 0.25dB. The sensitivity parameters (NormX, NormY, and NormZ), the diode compression parameter (DCP) and the conversion factor (ConvF) of the probe are tested. The calibration data are as below:

➤ ET3DV6 sn1788

Sensitivity	X axis : 1.73 μV	Y axis : 1.59 μV	Z axis : 1.72 μV	
Diode compression point	X axis : 95 mV	Y axis : 98 mV	Z axis : 91 mV	
Conversion factor (Head / Body)	Frequency (MHz)	X axis	Y axis	Z axis
	800~1000	6.55 / 6.34	6.55 / 6.34	6.55 / 6.34
	1850~2050	5.13 / 4.73	5.13 / 4.73	5.13 / 4.73
Boundary effect (Head / Body)	Frequency (MHz)	Alpha	Depth	
	800~1000	0.44 / 0.50	2.65 / 2.48	
	1850~2050	0.75 / 0.74	1.75 / 1.99	

NOTE: The probe parameters have been calibrated by the SPEAG.

5.2 DATA Acquisition Electronics (DAE)

The data acquisition electronics (DAE4) consists of a highly sensitive electrometer-grade preamplifier with auto-zeroing, a channel and gain-switching multiplexer, a fast 16 bit AD-converter and a command decoder and control logic unit. Transmission to the measurement server is accomplished through an optical downlink for data and status information as well as an optical uplink for commands and the clock.

The mechanical probe mounting device includes two different sensor systems for frontal and sideways probe contacts. They are used for mechanical surface detection and probe collision detection.

The input impedance of the DAE4 is 200M Ohm; the inputs are symmetrical and floating. Common mode rejection is above 80dB.

5.3 Robot

The DASY5 system uses the high precision robots TX90 XL type out of the newer series from Stäubli SA (France). For the 6-axis controller DASY5 system, the CS8C robot controller version from Stäubli is used. The XL robot series have many features that are important for our application:

- High precision (repeatability 0.02 mm)
- High reliability (industrial design)
- Jerk-free straight movements
- Low ELF interference (the closed metallic construction shields against motor control fields)
- 6-axis controller

5.4 Measurement Server

The DASY5 measurement server is based on a PC/104 CPU board with
400 MHz CPU
128 MB chipdisk and
128 MB RAM.

Communication with
the DAE4 electronic box
the 16-bit AD-converter system for optical detection and digital I/O interface.

The measurement server performs all the real-time data evaluation for field measurements and surface detection, controls robot movements and handles safety operations.

5.5 SAM Twin Phantom

The SAM twin phantom is a fiberglass shell phantom with 2mm shell thickness (except the ear region where shell thickness increases to 6mm). It has three measurement areas:

- Left head
- Right head
- Flat phantom

The bottom plate contains three pair of bolts for locking the device holder. The device holder positions are adjusted to the standard measurement positions in the three sections. A white cover is provided to tap the phantom during off-periods to prevent water evaporation and changes in the liquid parameters. On the phantom top, three reference markers are provided to identify the phantom position with respect to the robot.

The phantom can be used with the following tissue simulating liquids:

- *Water-sugar based liquid
- *Glycol based liquids

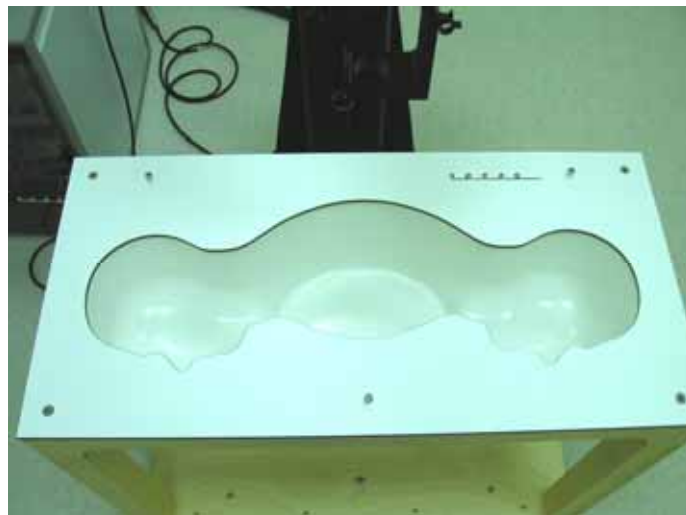

Fig. 5.3 Top View of Twin Phantom



Fig. 5.4 Bottom View of Twin Phantom

5.6 Device Holder for SAM Twin Phantom

The SAR in the Phantom is approximately inversely proportional to the square of the distance between the source and the liquid surface. For a source in 5 mm distance, a positioning uncertainty of $\pm 0.5\text{mm}$ would produce a SAR uncertainty of $\pm 20\%$. An accurate device position is therefore crucial for accurate and repeatable measurement. The position in which the devices must be measured, are defined by the standards.

The DASY5 device holder is designed to cope with different positions given in the standard. It has two scales for the device rotation (with respect to the body axis) and the device inclination (with respect to the line between the ear reference points). The rotation centers for both scales is the ear reference point (EPR).

Thus the device needs no repositioning when changing the angles.

The DASY5 device holder has been made out of low-loss POM material having the following dielectric parameters: relative permittivity $\epsilon_r = 3$ and loss tangent $\delta = 0.02$. The amount of dielectric material has been reduced in the closest vicinity of the device, since measurements have suggested that the influence of the clamp on the test results could thus be lowered.



Fig. 5.5 Device Holder



5.7 Data Storage and Evaluation

5.7.1 Data Storage

The DASY5 software stores the assessed data from the data acquisition electronics as raw data (in microvolt readings from the probe sensors), together with all the necessary software parameters for the data evaluation (probe calibration data, liquid parameters and device frequency and modulation data) in measurement files. The post-processing software evaluates the desired unit and format for output each time the data is visualized or exported. This allows verification of the complete software setup even after the measurement and allows correction of erroneous parameter settings. For example, if a measurement has been performed with an incorrect crest factor parameter in the device setup, the parameter can be corrected afterwards and the data can be reevaluated.

The measured data can be visualized or exported in different units or formats, depending on the selected probe type (e.g., [V/m], [A/m], [mW/g]). Some of these units are not available in certain situations or give meaningless results, e.g., a SAR-output in a non-loss media, will always be zero. Raw data can also be exported to perform the evaluation with other software packages.

5.7.2 Data Evaluation

The DASY5 post-processing software (SEMCAD) automatically executes the following procedures to calculate the field units from the microvolt readings at the probe connector. The parameters used in the evaluation are stored in the configuration modules of the software :

- Probe parameters :**
 - Sensitivity Norm_i, a_{i,0}, a_{i,1}, a_{i,2}
 - Conversion factor ConvF_i
 - Diode compression point dcp_i
- Device parameters :**
 - Frequency f
 - Crest factor cf
- Media parameters :**
 - Conductivity
 - Density

These parameters must be set correctly in the software. They can be found in the component documents or they can be imported into the software from the configuration files issued for the DASY5 components. In the direct measuring mode of the multi-meter option, the parameters of the actual system setup are used. In the scan visualization and export modes, the parameters stored in the corresponding document files are used.

The first step of the evaluation is a linearization of the filtered input signal to account for the compression characteristics of the detector diode. The compensation depends on the input signal, the diode type and the DC-transmission factor from the diode to the evaluation electronics. If the exciting field is pulsed, the crest factor of the signal must be known to correctly compensate for peak power.

The formula for each channel can be given as :

$$V_i = U_i + U_i^2 \cdot \frac{cf}{dcp_i}$$

with V_i = compensated signal of channel i ($i = x, y, z$)
 U_i = input signal of channel i ($i = x, y, z$)
 cf = crest factor of exciting field (DASY parameter)
 dcp_i = diode compression point (DASY parameter)

From the compensated input signals, the primary field data for each channel can be evaluated :

E-field probes : $E_i = \sqrt{\frac{V_i}{Norm_i ConvF}}$

H-field probes : $H_i = \sqrt{V_i} \frac{a_{i0} + a_{i1}f + a_{i2}f^2}{f}$

with V_i = compensated signal of channel i ($i = x, y, z$)
 $Norm_i$ = sensor sensitivity of channel i ($i = x, y, z$)
 $\mu V/(V/m)^2$ for E-field Probes
 $ConvF$ = sensitivity enhancement in solution
 a_{ij} = sensor sensitivity factors for H-field probes
 f = carrier frequency [GHz]
 E_i = electric field strength of channel i in V/m
 H_i = magnetic field strength of channel i in A/m

The RSS value of the field components gives the total field strength (Hermitian magnitude) :

$$E_{tot} = \sqrt{E_x^2 + E_y^2 + E_z^2}$$

The primary field data are used to calculate the derived field units.

$$SAR = E_{tot}^2 \cdot \frac{\sigma}{\rho \cdot 1000}$$

with SAR = local specific absorption rate in mW/g
 E_{tot} = total field strength in V/m
 σ = conductivity in [mho/m] or [Siemens/m]
 ρ = equivalent tissue density in g/cm³

* Note that the density is set to 1, to account for actual head tissue density rather than the density of the tissue simulating liquid.

The power flow density is calculated assuming the excitation field to be a free space field.

$$P_{pwe} = \frac{E_{tot}^2}{3770} \quad \text{or} \quad P_{pwe} = H_{tot}^2 \cdot 37.7$$

with P_{pwe} = equivalent power density of a plane wave in mW/cm²
 E_{tot} = total electric field strength in V/m
 H_{tot} = total magnetic field strength in A/m



5.8 Test Equipment List

Manufacturer	Name of Equipment	Type/Model	Serial Number	Calibration	
				Last Cal.	Due Date
SPEAG	Dosimetric E-Filed Probe	ET3DV6	1788	Sep. 23, 2008	Sep. 22, 2009
SPEAG	835MHz System Validation Kit	D835V2	499	Mar. 17, 2008	Mar. 16, 2010
SPEAG	1900MHz System Validation Kit	D1900V2	5d041	Mar. 28, 2008	Mar. 27, 2010
SPEAG	Data Acquisition Electronics	DAE4	778	Sep. 22, 2008	Sep. 21, 2009
SPEAG	Device Holder	N/A	N/A	NCR	NCR
SPEAG	SAM Phantom	QD 000 P40 C	TP-1446	NCR	NCR
SPEAG	SAM Phantom	QD 000 P40 C	TP-1383	NCR	NCR
Agilent	PNA Series Network Analyzer	E8358A	US40260131	Apr. 02, 2008	Apr. 01, 2009
Agilent	Wireless Communication Test Set	E5515C	GB46311322	Dec. 22, 2006	Dec. 21, 2008
R&S	Universal Radio Communication Tester	CMU200	114256	Dec.11, 2007	Dec. 10, 2008
Agilent	Dielectric Probe Kit	85070D	US01440205	NCR	NCR
Agilent	Dual Directional Coupler	778D	50422	NCR	NCR
AR	Power Amplifier	5S1G4M2	0328767	NCR	NCR
R&S	Power Meter	NRVD	101394	Oct. 20, 2008	Oct. 19, 2009
R&S	Power Sensor	NRV-Z1	100130	Oct. 20, 2008	Oct. 19, 2009

Table 5.1 Test Equipment List

6. Tissue Simulating Liquids

For the measurement of the field distribution inside the SAM phantom with DASY5, the phantom must be filled with around 25 liters of homogeneous tissue simulating liquid. The liquid height from the ear reference point (ERP) of the phantom to the liquid top surface is (head SAR) or from the flat phantom to the liquid top surface (body SAR) is 15.2cm.

The following ingredients for tissue simulating liquid are used:

- **Water:** deionized water (pure H₂O), resistivity $\geq 16\text{M}\Omega$ - as basis for the liquid
- **Sugar:** refined sugar in crystals, as available in food shops – to reduce relative permittivity
- **Salt:** pure NaCl – to increase conductivity
- **Cellulose:** Hydroxyethyl-cellulose, medium viscosity (75-125 mPa.s, 2% in water, 20°C), CAS#54290-to increase viscosity and to keep sugar in solution.
- **Preservative:** Preventol D-7 Bayer AG, D-51368 Leverkusen, CAS#55965-84-9- to prevent the spread of bacteria and molds.
- **DGMBE:** Deithlenglycol-monobuthyl ether (DGMBE), Fluka Chemie GmbH, CAS#112-34-5 – to reduce relative permittivity.

Table 6.1 gives the recipes for one liter of head and body tissue simulating liquid for frequency band 850 MHz, 1900 MHz and 2450 MHz.

Ingredient	HSL-850	MSL-850	HSL-1900	MSL-1900	HSL-2450
Water	532.98 g	631.68 g	552.42 g	716.56 g	550.0 ml
Cellulose	0 g	0 g	0 g	0 g	0 g
Salt	18.3 g	11.72 g	3.06 g	4.0 g	0 g
Preventol D-7	2.4 g	1.2 g	0 g	0 g	0 g
Sugar	766.0 g	600.0 g	0 g	0 g	0 g
DGMBE	0 g	0 g	444.52 g	300.67 g	450.0 ml
Total amount	1 liter (1.3 kg)	1 liter (1.3 kg)	1 liter (1.0 kg)	1 liter (1.0 kg)	1 liter (1.0 kg)
Dielectric Parameters at 22°	f = 835 MHz $\epsilon_r = 41.5 \pm 5\%$, $\sigma = 0.90 \pm 5\%$ S/m	f=835 MHz $\epsilon_r = 55.2 \pm 5\%$, $\sigma = 0.97 \pm 5\%$ S/m	f= 1900 MHz $\epsilon_r = 40.0 \pm 5\%$, $\sigma = 1.4 \pm 5\%$ S/m	f= 1900 MHz $\epsilon_r = 53.3 \pm 5\%$, $\sigma = 1.52 \pm 5\%$ S/m	f = 2450MHz $\epsilon_r = 39 \pm 5\%$, $\sigma = 1.84 \pm 5\%$ S/m

Table 6.1 Recipes for Tissue Simulating Liquid

The dielectric parameters of the liquids were verified prior to the SAR evaluation using an Agilent 85070D Dielectric Probe Kit and an Agilent Network Analyzer.

Table 6.2 shows the measuring results for head and muscle simulating liquid.

Band	Position	Temperature ()	Frequency (MHz)	Conductivity (σ)	Permittivity (ε _r)	Measurement Date
GSM850	Head	21.4	824.2	0.891	43.5	Nov. 09, 2008
			836.4	0.905	43.4	
			848.8	0.916	43.3	
		21.2	824.2	0.890	43.4	Nov. 12, 2008
			836.4	0.903	43.3	
			848.8	0.914	43.2	
	Body	21.3	824.2	0.942	52.7	Nov. 09, 2008
			836.4	0.954	52.6	
			848.8	0.967	52.5	
		21.2	824.2	0.946	53.1	Nov. 12, 2008
			836.4	0.958	52.9	
			848.8	0.971	52.8	
21.4	824.2	0.942	52.7	Jan. 15, 2009		
	836.4	0.955	52.6			
	848.8	0.967	52.5			
GSM1900	Head	21.5	1850.2	1.34	41.9	Nov. 09, 2008
			1880.0	1.37	41.8	
			1909.8	1.41	41.7	
		21.5	1850.2	1.41	38.3	Jan. 14, 2009
			1880.0	1.44	38.1	
			1909.8	1.47	38.0	
	Body	21.6	1850.2	1.48	51.1	Nov. 09, 2008
			1880.0	1.51	51.1	
			1909.8	1.54	51.0	
		21.4	1850.2	1.48	51.0	Nov. 12, 2008
			1880.0	1.51	51.0	
			1909.8	1.54	50.9	
		21.4	1850.2	1.51	51.7	Jan. 14, 2009
			1880.0	1.55	51.6	
			1909.8	1.58	51.6	
802.11b/g	Head	21.4	2412	1.82	37.8	Nov. 11, 2008
			2437	1.83	37.7	
			2462	1.86	37.6	

Table 6.2 Measuring Results for Simulating Liquid

The measuring data are consistent with $\epsilon_r = 41.5 \pm 5\%$ and $\sigma = 0.9 \pm 5\%$ for head GSM850, $\epsilon_r = 55.2 \pm 5\%$ and $\sigma = 0.97 \pm 5\%$ for body GSM850, $\epsilon_r = 40.0 \pm 5\%$ and $\sigma = 1.4 \pm 5\%$ for head GSM1900, $\epsilon_r = 53.3 \pm 5\%$ and $\sigma = 1.52 \pm 5\%$ for body GSM1900 and $\epsilon_r = 39.2 \pm 5\%$, $\sigma = 1.80 \pm 5\%$ for head 802.11b/g.

7. Uncertainty Assessment

The component of uncertainty may generally be categorized according to the methods used to evaluate them. The evaluation of uncertainty by the statistical analysis of a series of observations is termed a Type A evaluation of uncertainty. The evaluation of uncertainty by means other than the statistical analysis of a series of observation is termed a Type B evaluation of uncertainty. Each component of uncertainty, however evaluated, is represented by an estimated standard deviation, termed standard uncertainty, which is determined by the positive square root of the estimated variance.

A Type A evaluation of standard uncertainty may be based on any valid statistical method for treating data. This includes calculating the standard deviation of the mean of a series of independent observations; using the method of least squares to fit a curve to the data in order to estimate the parameter of the curve and their standard deviations; or carrying out an analysis of variance in order to identify and quantify random effects in certain kinds of measurement.

A type B evaluation of standard uncertainty is typically based on scientific judgment using all of the relevant information available. These may include previous measurement data, experience and knowledge of the behavior and properties of relevant materials and instruments, manufacture’s specification, data provided in calibration reports and uncertainties assigned to reference data taken from handbooks. Broadly speaking, the uncertainty is either obtained from an outdoor source or obtained from an assumed distribution, such as the normal distribution, rectangular or triangular distributions indicated in Table 7.1

Uncertainty Distributions	Normal	Rectangular	Triangular	U-shape
Multiplying factor^(a)	1/k ^(b)	1/ 3	1/ 6	1/ 2

(a) standard uncertainty is determined as the product of the multiplying factor and the estimated range of variations in the measured quantity

(b) is the coverage factor

Table 7.1 Multiplying Factions for Various Distributions

The combined standard uncertainty of the measurement result represents the estimated standard deviation of the result. It is obtained by combining the individual standard uncertainties of both Type A and Type B evaluation using the usual “root-sum-squares” (RSS) methods of combining standard deviations by taking the positive square root of the estimated variances.

Expanded uncertainty is a measure of uncertainty that defines an interval about the measurement result within which the measured value is confidently believed to lie. It is obtained by multiplying the combined standard uncertainty by a coverage factor. Typically, the coverage factor ranges from 2 to 3. Using a coverage factor allows the true value of a measured quantity to be specified with a defined probability within the specified uncertainty range. For purpose of this document, a coverage factor two is used, which corresponds to confidence interval of about 95 %. The DASYS5 uncertainty Budget is showed in Table 7.2.



Error Description	Uncertainty Value ± %	Probability Distribution	Divisor	Ci (1g)	Standard Unc. (1g)	vi or Veff
Measurement Equipment						
Probe Calibration	±5.9 %	Normal	1	1	±5.9 %	∞
Axial Isotropy	±4.7 %	Rectangular	√3	0.7	±1.9 %	∞
Hemispherical Isotropy	±9.6 %	Rectangular	√3	0.7	±3.9 %	∞
Boundary Effects	±1.0 %	Rectangular	√3	1	±0.6 %	∞
Linearity	±4.7 %	Rectangular	√3	1	±2.7 %	∞
System Detection Limits	±1.0 %	Rectangular	√3	1	±0.6 %	∞
Readout Electronics	±0.3 %	Normal	1	1	±0.3 %	∞
Response Time	±0.8 %	Rectangular	√3	1	±0.5 %	∞
Integration Time	±2.6 %	Rectangular	√3	1	±1.5 %	∞
RF Ambient Noise	±3.0 %	Rectangular	√3	1	±1.7 %	∞
RF Ambient Reflections	±3.0 %	Rectangular	√3	1	±1.7 %	∞
Probe Positioner	±0.4 %	Rectangular	√3	1	±0.2 %	∞
Probe Positioning	±2.9 %	Rectangular	√3	1	±1.7 %	∞
Max. SAR Eval.	±1.0 %	Rectangular	√3	1	±0.6 %	∞
Test Sample Related						
Device Positioning	±2.9 %	Normal	1	1	±2.9	145
Device Holder	±3.6 %	Normal	1	1	±3.6	5
Power Drift	±5.0 %	Rectangular	√3	1	±2.9	∞
Phantom and Setup						
Phantom Uncertainty	±4.0 %	Rectangular	√3	1	±2.3	∞
Liquid Conductivity (target)	±5.0 %	Rectangular	√3	0.64	±1.8	∞
Liquid Conductivity (meas.)	±2.5 %	Normal	1	0.64	±1.6	∞
Liquid Permittivity (target)	±5.0 %	Rectangular	√3	0.6	±1.7	∞
Liquid Permittivity (meas.)	±2.5 %	Normal	1	0.6	±1.5	∞
Combined Standard Uncertainty					±10.9	387
Coverage Factor for 95 %		K=2				
Expanded uncertainty (Coverage factor = 2)					±21.9	

Table 7.2 Uncertainty Budget of DASY5

8. SAR Measurement Evaluation

Each DASY5 system is equipped with one or more system validation kits. These units, together with the predefined measurement procedures within the DASY5 software, enable the user to conduct the system performance check and system validation. System validation kit includes a dipole, tripod holder to fix it underneath the flat phantom and a corresponding distance holder.

8.1 Purpose of System Performance check

The system performance check verifies that the system operates within its specifications. System and operator errors can be detected and corrected. It is recommended that the system performance check be performed prior to any usage of the system in order to guarantee reproducible results. The system performance check uses normal SAR measurements in a simplified setup with a well characterized source. This setup was selected to give a high sensitivity to all parameters that might fail or vary over time. The system check does not intend to replace the calibration of the components, but indicates situations where the system uncertainty is exceeded due to drift or failure.

8.2 System Setup

In the simplified setup for system evaluation, the DUT is replaced by a calibrated dipole and the power source is replaced by a continuous wave which comes from a signal generator at frequency 835 MHz and 1900 MHz. The calibrated dipole must be placed beneath the flat phantom section of the SAM twin phantom with the correct distance holder. The distance holder should touch the phantom surface with a light pressure at the reference marking and be oriented parallel to the long side of the phantom. The equipment setup is shown below:

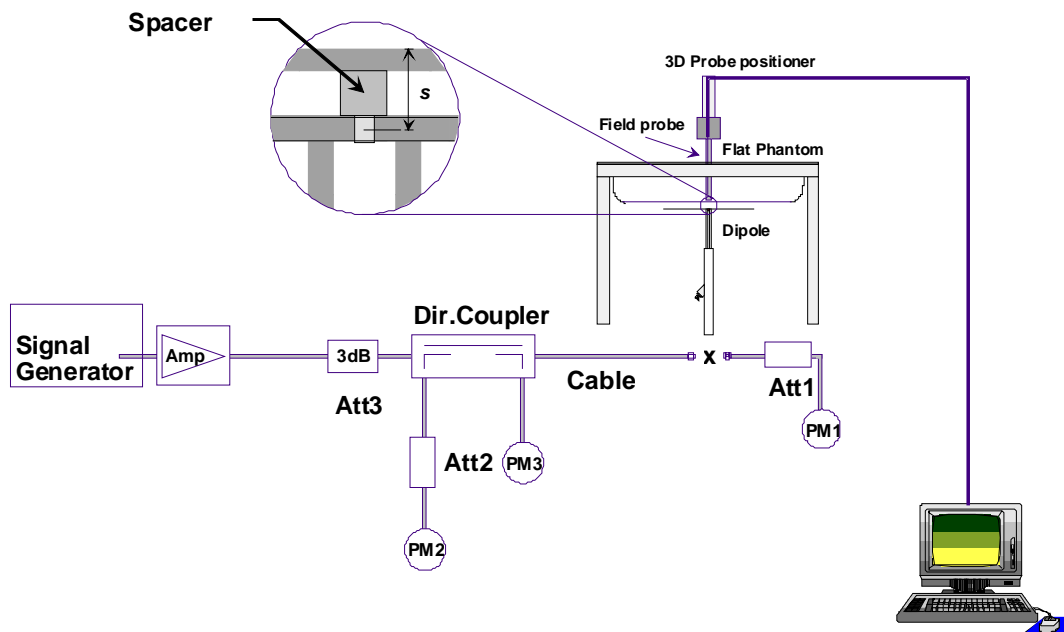

Fig. 8.1 System Setup for System Evaluation

1. Signal Generator
2. Amplifier
3. Directional Coupler
4. Power Meter
5. 835 MHz or 1900 MHz or 2450 MHz Dipole

The output power on dipole port must be calibrated to 20dBm (100mW) before dipole is connected.



Fig 8.2 Dipole Setup

8.3 Validation Results

Comparing to the original SAR value provided by SPEAG, the validation data should be within its specification of 10 %. Table 8.1 shows the target SAR and measured SAR after normalized to 1W input power.

Frequency	Position	SAR	Target (W/kg)	Measurement data (W/kg)	Variation	Measurement Date
835 MHz	Head	SAR (1g)	9.16	9.43	2.9 %	Nov. 09, 2008
		SAR (10g)	6.00	6.27	4.5 %	
		SAR (1g)	9.16	8.99	-1.9 %	Nov. 12, 2008
		SAR (10g)	6.00	5.97	-0.5 %	
	Body	SAR (1g)	9.52	9.62	1.1 %	Nov. 09, 2008
		SAR (10g)	6.37	6.42	0.8 %	Nov. 12, 2008
		SAR (1g)	9.52	8.83	-7.2 %	
		SAR (10g)	6.37	5.87	-7.8 %	
		SAR (1g)	9.52	9.71	2.0 %	Jan. 15, 2009
		SAR (10g)	6.37	6.47	1.6 %	
1900 MHz	Head	SAR (1g)	39.5	37.4	-5.3 %	Nov. 09, 2008
		SAR (10g)	20.6	19.5	-5.3 %	
		SAR (1g)	39.5	39.3	-0.5 %	Jan. 14, 2009
		SAR (10g)	20.6	20.4	-1.0 %	
	Body	SAR (1g)	40.1	42.1	5.0 %	Nov. 09, 2008
		SAR (10g)	21.3	22.3	4.7 %	Nov. 12, 2008
		SAR (1g)	40.1	38.5	-4.0 %	
		SAR (10g)	21.3	20.1	-5.6 %	
		SAR (1g)	40.1	43.2	7.7 %	Jan. 14, 2009
		SAR (10g)	21.3	22.9	7.5 %	
2450 MHz	Head	SAR (1g)	52.7	52.6	-0.2 %	Nov. 11, 2008
		SAR (10g)	24.5	24.6	0.4 %	

Table 8.1 Target and Measurement Data Comparison

The table above indicates the system performance check can meet the variation criterion.



9. Description for DUT Testing Position

This DUT was tested in six different positions. They are right cheek, right tilted, left cheek, left tilted, body worn with face and body worn with bottom as illustrated below:

- 1) “Cheek Position”
 - i) To position the device with the vertical center line of the body of the device and the horizontal line crossing the center piece in a plane parallel to the sagittal plane of the phantom. While maintaining the device in this plane, align the vertical center line with the reference plane containing the three ear and mouth reference point (M, RE and LE) and align the center of the ear piece with the line RE-LE.
 - ii) To move the device towards the phantom with the ear piece aligned with the line LE-RE until the phone touched the ear. While maintaining the device in the reference plane and maintaining the phone contact with the ear, move the bottom of the phone until any point on the front side is in contact with the cheek of the phantom or until contact with the ear is lost (see Fig. 9.1).
- 2) “Tilted Position”
 - i) To position the device in the “cheek” position described above.
 - ii) While maintaining the device the reference plane described above and pivoting against the ear, move it outward away from the mouth by an angle of 15 degrees or until contact with the ear is lost (see Fig. 9.2).
- 3) “Body Worn”
 - i) To position the device parallel to the phantom surface.
 - ii) To adjust the phone parallel to the flat phantom.
 - iii) To adjust the distance between the EUT surface and the flat phantom to 1.5 cm or holster surface and the flat phantom to 0 cm.

Remark: Please refer to Appendix E for the test setup photos.

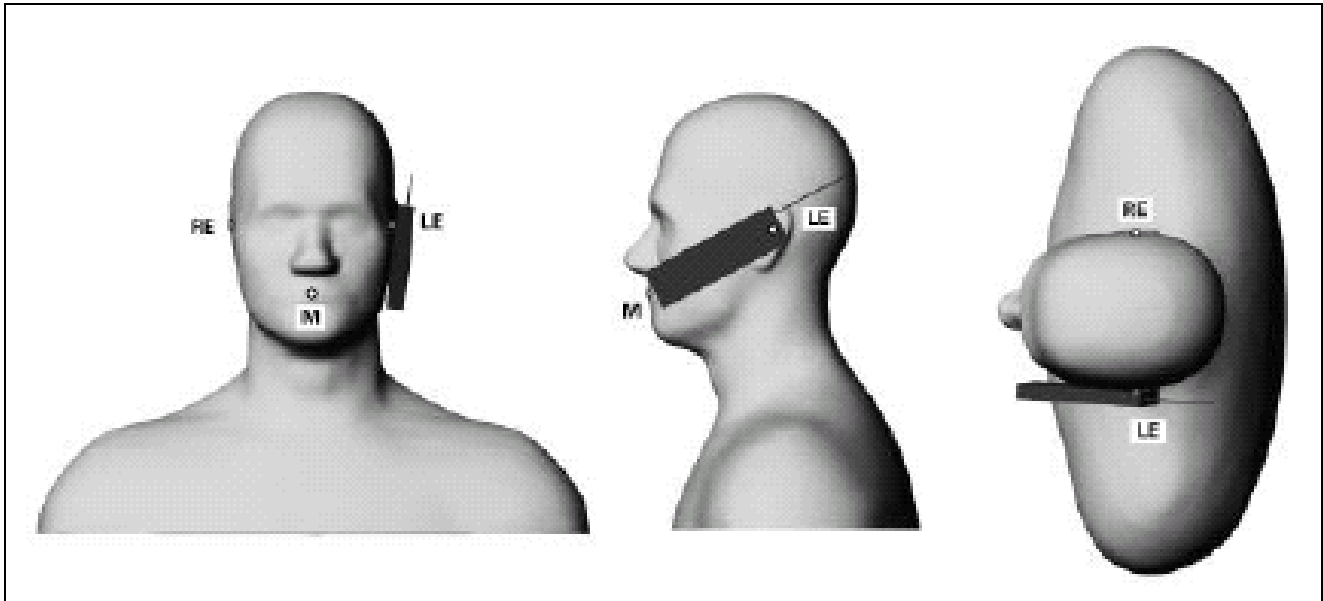

Fig. 9.1 Phone Position 1, “Cheek” or “Touch” Position. The reference points for the right ear (RE), left ear (LE) and mouth (M), which define the plane for phone positioning, are indicated.

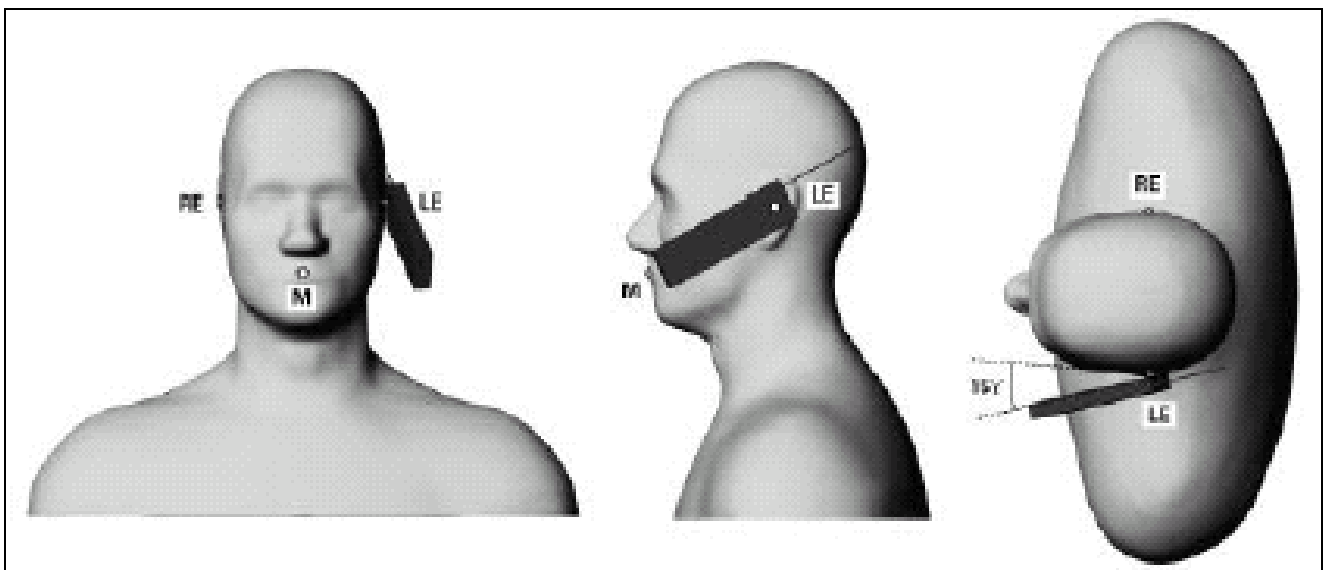

Fig. 9.2 Phone Position 2, “Tilted Position”. The reference point for the right ear (RE), left ear (LE) and mouth (M), which define the plane for phone positioning, are indicated.

10. Measurement Procedures

The measurement procedures are as follows:

- Linking DUT with base station emulator CMU200 in middle channel
- Setting CMU200 to allow DUT to radiate maximum output power
- Measuring output power through RF cable and power meter
- Placing the DUT in the positions described in the last section
- Setting scan area, grid size and other setting on the DASY5 software
- Taking data for the middle channel on each testing position
- Finding out the largest SAR result on these testing positions of each band
- Measuring output power and SAR results for the low and high channels in this worst case testing position

According to the IEEE P1528 standard, the recommended procedure for assessing the peak spatial-average SAR value consists of the following steps:

- Power reference measurement
- Area scan
- Zoom scan
- Power reference measurement

10.1 Spatial Peak SAR Evaluation

The procedure for spatial peak SAR evaluation has been implemented according to the IEEE P1528 standard. It can be conducted for 1g and 10g, as well as for user-specific masses. The DASY5 software includes all numerical procedures necessary to evaluate the spatial peak SAR value.

The base for the evaluation is a "cube" measurement. The measured volume must include the 1g and 10g cubes with the highest averaged SAR values. For that purpose, the center of the measured volume is aligned to the interpolated peak SAR value of a previously performed area scan.

The entire evaluation of the spatial peak values is performed within the post-processing engine (SEMCAD). The system always gives the maximum values for the 1g and 10g cubes. The algorithm to find the cube with highest averaged SAR is divided into the following stages:

- extraction of the measured data (grid and values) from the Zoom Scan
- calculation of the SAR value at every measurement point based on all stored data (A/D values and measurement parameters)
- generation of a high-resolution mesh within the measured volume
- interpolation of all measured values from the measurement grid to the high-resolution grid
- extrapolation of the entire 3-D field distribution to the phantom surface over the distance from sensor to surface
- calculation of the averaged SAR within masses of 1g and 10g



10.2 Scan Procedures

First Area Scan is used to locate the approximate location(s) of the local peak SAR value(s). The measurement grid within an Area Scan is defined by the grid extent, grid step size and grid offset. Next, in order to determine the EM field distribution in a three-dimensional spatial extension, Zoom Scan is required. The Zoom Scan measures 5x5x7 points with step size 8, 8 and 5 mm. The Zoom Scan is performed around the highest E-field value to determine the averaged SAR-distribution over 1 g.

10.3 SAR Averaged Methods

In DASYS, the interpolation and extrapolation are both based on the modified Quadratic Shepard's method. The interpolation scheme combines a least-square fitted function method and a weighted average method which are the two basic types of computational interpolation and approximation.

Extrapolation routines are used to obtain SAR values between the lowest measurement points and the inner phantom surface. The extrapolation distance is determined by the surface detection distance and the probe sensor offset. The uncertainty increases with the extrapolation distance. To keep the uncertainty within 1% for the 1 g and 10 g cubes, the extrapolation distance should not be larger than 5 mm.

11. SAR Test Results

11.1 Conducted Power

11.1.1 Description of the Conducted Output Power Measurement

A base station simulator was used to establish communication with the EUT. Its parameters were set to transmit the maximum power on the EUT. The measured power in the radio frequency on the transmitter output terminals shall be reported.

11.1.2 Test Procedures

1. The transmitter output port was connected to base station.
2. Set EUT at maximum power through base station.
3. Select lowest, middle, and highest channels for each band, different modulation (GMSK and 8PSK), and different uplink slot setting.
4. The test results of each mode are shown in section 11.1.4.

11.1.3 Test Setup

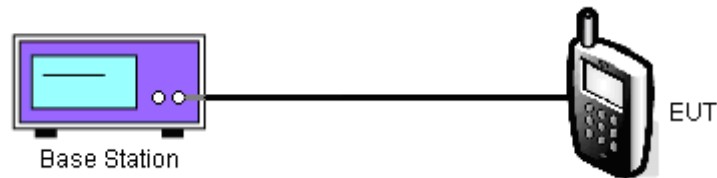

11.1.4 Test Result of Conducted Output Power

Mode \ Band Channel	GSM 850 (dBm)			GSM 1900 (dBm)		
	128	189	251	512	661	810
GSM	32.90	32.96	33.00	29.18	29.44	29.57
GPRS Multi-slot Class 8 (1 uplink slot)	32.94	32.99	33.03	29.15	29.42	29.55
GPRS Multi-slot Class 10 (2 uplink slots)	31.14	31.20	31.26	27.36	27.62	27.75
GPRS Multi-slot Class 12 (4 uplink slots)	27.40	27.46	27.50	23.64	23.87	24.00
EDGE Multi-slot Class 8 (1 uplink slot)	26.74	26.70	26.56	24.95	24.92	24.87
EDGE Multi-slot Class 10 (2 uplink slots)	24.59	24.49	24.46	23.35	23.37	23.30
EDGE Multi-slot Class 12 (4 uplink slots)	20.42	20.38	20.28	19.48	19.51	19.44

11.2 Test Records for Head SAR Test

Sample	Position	Mode	Channel	Frequency (MHz)	Modulation Type	Measured 1g SAR (W/kg)	Limit (W/kg)	Result
1	Right Cheek	GSM850	189	836.4	GMSK	1.09	1.6	Pass
1	Right Tilted	GSM850	189	836.4	GMSK	1.07	1.6	Pass
1	Left Cheek	GSM850	189	836.4	GMSK	0.796	1.6	Pass
1	Left Tilted	GSM850	189	836.4	GMSK	0.743	1.6	Pass
1	Right Cheek	GSM850	128	824.2	GMSK	0.907	1.6	Pass
1	Right Cheek	GSM850	251	848.8	GMSK	1.33	1.6	Pass
1	Right Tilted	GSM850	128	824.2	GMSK	0.892	1.6	Pass
1	Right Tilted	GSM850	251	848.8	GMSK	1.3	1.6	Pass
2	Right Cheek	GSM850	128	824.2	GMSK	0.74	1.6	Pass
2	Right Cheek	GSM850	189	836.4	GMSK	0.891	1.6	Pass
2	Right Cheek	GSM850	251	848.8	GMSK	1.13	1.6	Pass
1	Right Cheek	GSM1900	661	1850.2	GMSK	0.44	1.6	Pass
1	Right Tilted	GSM1900	661	1850.2	GMSK	0.399	1.6	Pass
1	Left Cheek	GSM1900	661	1850.2	GMSK	0.304	1.6	Pass
1	Left Tilted	GSM1900	661	1850.2	GMSK	0.306	1.6	Pass
1	Right Cheek	GSM1900	512	1880.0	GMSK	0.464	1.6	Pass
1	Right Cheek	GSM1900	810	1909.8	GMSK	0.457	1.6	Pass
2	Right Cheek	GSM1900	512	1880.0	GMSK	0.528	1.6	Pass
2	Right Cheek	GSM1900	661	1850.2	GMSK	0.51	1.6	Pass
2	Right Cheek	GSM1900	810	1909.8	GMSK	0.567	1.6	Pass



11.3 Test Records for Body SAR Test with 1.5cm Gap

Sample	Position	Band	Channel	Frequency (MHz)	Modulation Type	Measured 1g SAR (W/kg)	Limit (W/kg)	Result
1	Face with 1.5cm Gap	GSM850 (GPRS 12)	189	836.4	GMSK	0.238	1.6	Pass
1	Bottom with 1.5cm Gap	GSM850 (GPRS 12)	189	836.4	GMSK	0.187	1.6	Pass
1	Face with 1.5cm Gap	GSM850 (GPRS 10)	189	836.4	GMSK	0.285	1.6	Pass
1	Face with 1.5cm Gap	GSM850 (EDGE 12)	189	836.4	8PSK	0.06	1.6	Pass
1	Face with 1.5cm Gap	GSM850 (EDGE 10)	189	836.4	8PSK	0.079	1.6	Pass
1	Face with 1.5cm Gap	GSM850 (EDGE 8)	189	836.4	8PSK	0.065	1.6	Pass
1	Face with 1.5cm Gap	GSM850 Voice + BT Link	189	836.4	GMSK	0.215	1.6	Pass
1	Face with 1.5cm Gap	GSM850 (GPRS 10)	128	824.2	GMSK	0.257	1.6	Pass
1	Face with 1.5cm Gap	GSM850 (GPRS 10)	251	848.8	GMSK	0.387	1.6	Pass
2	Face with 1.5cm Gap	GSM850 (GPRS 10)	128	824.2	GMSK	0.2	1.6	Pass
2	Face with 1.5cm Gap	GSM850 (GPRS 10)	189	836.4	GMSK	0.251	1.6	Pass
2	Face with 1.5cm Gap	GSM850 (GPRS 10)	251	848.8	GMSK	0.29	1.6	Pass
1	Face with 1.5cm Gap	GSM1900 (GPRS 12)	661	1880.0	GMSK	0.147	1.6	Pass
1	Bottom with 1.5cm Gap	GSM1900 (GPRS 12)	661	1880.0	GMSK	0.188	1.6	Pass
1	Bottom with 1.5cm Gap	GSM1900 (GPRS 10)	661	1880.0	GMSK	0.212	1.6	Pass
1	Bottom with 1.5cm Gap	GSM1900 (EDGE 12)	661	1880.0	8PSK	0.073	1.6	Pass
1	Bottom with 1.5cm Gap	GSM1900 (EDGE 10)	661	1880.0	8PSK	0.092	1.6	Pass
1	Bottom with 1.5cm Gap	GSM1900 (EDGE 8)	661	1880.0	8PSK	0.063	1.6	Pass
1	Bottom with 1.5cm Gap	GSM1900 Voice + BT Link	661	1880.0	GMSK	0.156	1.6	Pass
1	Bottom with 1.5cm Gap	GSM1900 (GPRS 10)	512	1850.2	GMSK	0.230	1.6	Pass
1	Bottom with 1.5cm Gap	GSM1900 (GPRS 10)	810	1909.8	GMSK	0.175	1.6	Pass
2	Bottom with 1.5cm Gap	GSM1900 (GPRS 10)	512	1850.2	GMSK	0.114	1.6	Pass
2	Bottom with 1.5cm Gap	GSM1900 (GPRS 10)	661	1880.0	GMSK	0.075	1.6	Pass
2	Bottom with 1.5cm Gap	GSM1900 (GPRS 10)	810	1909.8	GMSK	0.064	1.6	Pass



11.4 Test Records for Body SAR Test with Holster

Sample	Holster	Position	Band	Channel	Frequency (MHz)	Modulation Type	Measured 1g SAR (W/kg)	Limit (W/kg)	Result
1	1	Face with 0cm Gap	GSM850 (GPRS 12)	189	836.4	GMSK	0.09	1.6	Pass
1	1	Bottom with 0cm Gap	GSM850 (GPRS 12)	189	836.4	GMSK	0.083	1.6	Pass
1	1	Face with 0cm Gap	GSM850 (GPRS 10)	189	836.4	GMSK	0.108	1.6	Pass
1	1	Face with 0cm Gap	GSM850 (EDGE 12)	189	836.4	8PSK	0.025	1.6	Pass
1	1	Face with 0cm Gap	GSM850 (EDGE 10)	189	836.4	8PSK	0.033	1.6	Pass
1	1	Face with 0cm Gap	GSM850 (EDGE 8)	189	836.4	8PSK	0.026	1.6	Pass
1	1	Face with 0cm Gap	GSM850 Voice + BT Link	189	836.4	GMSK	0.089	1.6	Pass
1	1	Face with 0cm Gap	GSM850 (GPRS 10)	128	824.2	GMSK	0.112	1.6	Pass
1	1	Face with 0cm Gap	GSM850 (GPRS 10)	251	848.8	GMSK	0.116	1.6	Pass
2	1	Face with 0cm Gap	GSM850 (GPRS 10)	128	824.2	GMSK	0.083	1.6	Pass
2	1	Face with 0cm Gap	GSM850 (GPRS 10)	189	836.4	GMSK	0.090	1.6	Pass
2	1	Face with 0cm Gap	GSM850 (GPRS 10)	251	848.8	GMSK	0.114	1.6	Pass
1	1	Face with 0cm Gap	GSM1900 (GPRS 12)	661	1880.0	GMSK	0.246	1.6	Pass
1	1	Face with 0cm Gap	GSM1900 (GPRS 10)	661	1880.0	GMSK	0.326	1.6	Pass
1	1	Face with 0cm Gap	GSM1900 (EDGE 12)	661	1880.0	8PSK	0.105	1.6	Pass
1	1	Face with 0cm Gap	GSM1900 (EDGE 10)	661	1880.0	8PSK	0.130	1.6	Pass
1	1	Face with 0cm Gap	GSM1900 (EDGE 8)	661	1880.0	8PSK	0.086	1.6	Pass
1	1	Face with 0cm Gap	GSM1900 Voice + BT Link	661	1880.0	GMSK	0.286	1.6	Pass
1	1	Face with 0cm Gap	GSM1900 (GPRS 10)	512	1850.2	GMSK	0.431	1.6	Pass
1	1	Face with 0cm Gap	GSM1900 (GPRS 10)	810	1909.8	GMSK	0.269	1.6	Pass
1	1	Bottom with 0cm Gap	GSM1900 (GPRS 10)	512	1850.2	GMSK	0.456	1.6	Pass
2	1	Bottom with 0cm Gap	GSM1900 (GPRS 10)	512	1850.2	GMSK	0.484	1.6	Pass
2	1	Bottom with 0cm Gap	GSM1900 (GPRS 10)	661	1880.0	GMSK	0.366	1.6	Pass
2	1	Bottom with 0cm Gap	GSM1900 (GPRS 10)	810	1909.8	GMSK	0.271	1.6	Pass
1	2	Face with 0cm Gap	GSM850 (GPRS 12)	189	836.4	GMSK	0.12	1.6	Pass
1	2	Face with 0cm Gap	GSM850 (GPRS 10)	189	836.4	GMSK	0.142	1.6	Pass
1	2	Face with 0cm Gap	GSM850 (EDGE 12)	189	836.4	8PSK	0.032	1.6	Pass
1	2	Face with 0cm Gap	GSM850 (EDGE 10)	189	836.4	8PSK	0.041	1.6	Pass
1	2	Face with 0cm Gap	GSM850 (EDGE 8)	189	836.4	8PSK	0.036	1.6	Pass
1	2	Face with 0cm Gap	GSM850 Voice + BT Link	189	836.4	GMSK	0.116	1.6	Pass
1	2	Face with 0cm Gap	GSM850 (GPRS 10)	128	824.2	GMSK	0.129	1.6	Pass
1	2	Face with 0cm Gap	GSM850 (GPRS10)	251	848.8	GMSK	0.197	1.6	Pass
2	2	Face with 0cm Gap	GSM850 (GPRS10)	128	824.2	GMSK	0.091	1.6	Pass
2	2	Face with 0cm Gap	GSM850 (GPRS10)	189	836.4	GMSK	0.094	1.6	Pass
2	2	Face with 0cm Gap	GSM850 (GPRS10)	251	848.8	GMSK	0.138	1.6	Pass
1	2	Face with 0cm Gap	GSM1900 (GPRS 12)	661	1880.0	GMSK	0.24	1.6	Pass
1	2	Face with 0cm Gap	GSM1900 (GPRS 10)	661	1880.0	GMSK	0.277	1.6	Pass
1	2	Face with 0cm Gap	GSM1900 (EDGE 12)	661	1880.0	8PSK	0.092	1.6	Pass
1	2	Face with 0cm Gap	GSM1900 (EDGE 10)	661	1880.0	8PSK	0.118	1.6	Pass
1	2	Face with 0cm Gap	GSM1900 (EDGE 8)	661	1880.0	8PSK	0.082	1.6	Pass
1	2	Face with 0cm Gap	GSM1900 Voice + BT Link	661	1880.0	GMSK	0.203	1.6	Pass
1	2	Face with 0cm Gap	GSM1900 (GPRS 10)	512	1850.2	GMSK	0.349	1.6	Pass
1	2	Face with 0cm Gap	GSM1900 (GPRS 10)	810	1909.8	GMSK	0.297	1.6	Pass
2	2	Face with 0cm Gap	GSM1900 (GPRS 10)	512	1850.2	GMSK	0.352	1.6	Pass
2	2	Face with 0cm Gap	GSM1900 (GPRS 10)	661	1880.0	GMSK	0.305	1.6	Pass
2	2	Face with 0cm Gap	GSM1900 (GPRS 10)	810	1909.8	GMSK	0.334	1.6	Pass

Sample	Holster	Position	Band	Channel	Frequency (MHz)	Modulation Type	Measured 1g SAR (W/kg)	Limit (W/kg)	Result
1	3	Face with 0cm Gap	GSM850 (GPRS 12)	189	836.4	GMSK	0.239	1.6	Pass
1	3	Bottom with 0cm Gap	GSM850 (GPRS 12)	189	836.4	GMSK	0.157	1.6	Pass
1	3	Face with 0cm Gap	GSM850 (GPRS 10)	189	836.4	GMSK	0.281	1.6	Pass
1	3	Face with 0cm Gap	GSM850 (EDGE 12)	189	836.4	8PSK	0.057	1.6	Pass
1	3	Face with 0cm Gap	GSM850 (EDGE 10)	189	836.4	8PSK	0.073	1.6	Pass
1	3	Face with 0cm Gap	GSM850 (EDGE 8)	189	836.4	8PSK	0.059	1.6	Pass
1	3	Face with 0cm Gap	GSM850 Voice + BT Link	189	836.4	GMSK	0.210	1.6	Pass
1	3	Face with 0cm Gap	GSM850 (GPRS 10)	128	824.2	GMSK	0.230	1.6	Pass
1	3	Face with 0cm Gap	GSM850 (GPRS 10)	251	848.8	GMSK	0.351	1.6	Pass
2	3	Face with 0cm Gap	GSM850 (GPRS 10)	128	824.2	GMSK	0.172	1.6	Pass
2	3	Face with 0cm Gap	GSM850 (GPRS 10)	189	836.4	GMSK	0.197	1.6	Pass
2	3	Face with 0cm Gap	GSM850 (GPRS 10)	251	848.8	GMSK	0.246	1.6	Pass
1	3	Face with 0cm Gap	GSM1900 (GPRS 12)	661	1880.0	GMSK	0.114	1.6	Pass
1	3	Bottom with 0cm Gap	GSM1900 (GPRS 12)	661	1880.0	GMSK	0.102	1.6	Pass
1	3	Face with 0cm Gap	GSM1900 (GPRS 10)	661	1880.0	GMSK	0.133	1.6	Pass
1	3	Face with 0cm Gap	GSM1900 (EDGE 12)	661	1880.0	8PSK	0.047	1.6	Pass
1	3	Face with 0cm Gap	GSM1900 (EDGE 10)	661	1880.0	8PSK	0.058	1.6	Pass
1	3	Face with 0cm Gap	GSM1900 (EDGE 8)	661	1880.0	8PSK	0.040	1.6	Pass
1	3	Face with 0cm Gap	GSM1900 Voice + BT Link	661	1880.0	GMSK	0.114	1.6	Pass
1	3	Face with 0cm Gap	GSM1900 (GPRS 10)	512	1850.2	GMSK	0.177	1.6	Pass
1	3	Face with 0cm Gap	GSM1900 (GPRS 10)	810	1909.8	GMSK	0.134	1.6	Pass
2	3	Face with 0cm Gap	GSM1900 (GPRS 10)	512	1850.2	GMSK	0.183	1.6	Pass
2	3	Face with 0cm Gap	GSM1900 (GPRS 10)	661	1880.0	GMSK	0.147	1.6	Pass
2	3	Face with 0cm Gap	GSM1900 (GPRS 10)	810	1909.8	GMSK	0.146	1.6	Pass

11.5 Volume Scan SAR

Sample	Position	Band	Channel	Frequency (MHz)	Measured 1g SAR (W/kg)	Multi Band 1g SAR (W/kg)	Limit (W/kg)	Result
1	Right Cheek	GSM850	251	848.8	1.41	1.45	1.6	Pass
		802.11g	6	2437	0.041			

Remark:

- The configuration of Sample 1 is 1D scanner, Battery 1 and Numeric Keypad.
- The configuration of Sample 2 is 2D scanner, Battery 2 and Qwerty Keypad.
- Holster 2 can only allow for face position.
- The worst configuration on worst position is used for the volume scan.
- The SAR to peak location separation ratio of WWAN and WLAN is as below:
 $\text{Summation SAR} = 1.33(\text{GSM850}) + 0.06(802.11\text{g}) = 1.39 \text{ W/kg}$
 $\text{Peak Location Spacing} = 3.95 \text{ cm}$
 $\text{SAR to Peak Location Spacing Ratio} = 1.39 / 3.95 = 0.352$
 According KDB 648474, the SAR to peak location separation ratio is larger than 0.3, so the simultaneous transmission SAR evaluation is required.
- Test Engineer : A-Rod Chen, Jason Wang, Robert Liu, and Gordon Lin



12. References

- [1] FCC 47 CFR Part 2 “Frequency Allocations and Radio Treaty Matters; General Rules and Regulations”
- [2] IEEE Std. P1528-2003, “Recommended Practice for Determining the Peak Spatial-Average Specific Absorption Rate (SAR) in the Human Head from Wireless Communications Devices: Measurement Techniques”, April 21, 2003
- [3] Supplement C (Edition 01-01) to OET Bulletin 65 (Edition 97-01), “Additional Information for Evaluating Compliance of Mobile and Portable Devices with FCC Limits for Human Exposure to RF Emissions”, June 2001
- [4] IEEE Std. C95.3-2002, “IEEE Recommended Practice for the Measurement of Potentially Hazardous Electromagnetic Fields-RF and Microwave”, 2002
- [5] IEEE Std. C95.1-1999, “IEEE Standard for Safety Levels with Respect to Human Exposure to Radio Frequency Electromagnetic Fields, 3 kHz to 300 GHz”, 1999
- [6] Robert J. Renka, “Multivariate Interpolation Of Large Sets Of Scattered Data”, University of North Texas ACM Transactions on Mathematical Software, vol. 14, no. 2, June 1988, pp. 139-148
- [7] DASY5 System Handbook

Appendix A - System Performance Check Data

Test Laboratory: Sporton International Inc. SAR/HAC Testing Lab

Date: 2008/11/9

System Check_Head_835MHz_20081109

DUT: Dipole 835 MHz

Communication System: CW; Frequency: 835 MHz; Duty Cycle: 1:1

Medium: HSL_850 Medium parameters used: $f = 835 \text{ MHz}$; $\sigma = 0.904 \text{ mho/m}$; $\epsilon_r = 43.4$; $\rho = 1000 \text{ kg/m}^3$

Ambient Temperature : 22.6 ; Liquid Temperature : 21.4

DASY5 Configuration:

- Probe: ET3DV6 - SN1788; ConvF(6.55, 6.55, 6.55); Calibrated: 2008/9/23
- Sensor-Surface: 4mm (Mechanical Surface Detection)
- Electronics: DAE4 Sn778; Calibrated: 2008/9/22
- Phantom: SAM - Front; Type: SAM; Serial: TP-1446
- Measurement SW: DASY5, V5.0 Build 120; SEMCAD X Version 13.2 Build 87

Pin=100mW/Area Scan (61x61x1): Measurement grid: dx=15mm, dy=15mm
Maximum value of SAR (interpolated) = 1.02 mW/g

Pin=100mW/Zoom Scan (7x7x7)/Cube 0: Measurement grid: dx=5mm, dy=5mm, dz=5mm
Reference Value = 35.3 V/m; Power Drift = -0.00522 dB

Peak SAR (extrapolated) = 1.3 W/kg

SAR(1 g) = 0.943 mW/g; SAR(10 g) = 0.627 mW/g

Maximum value of SAR (measured) = 1.02 mW/g

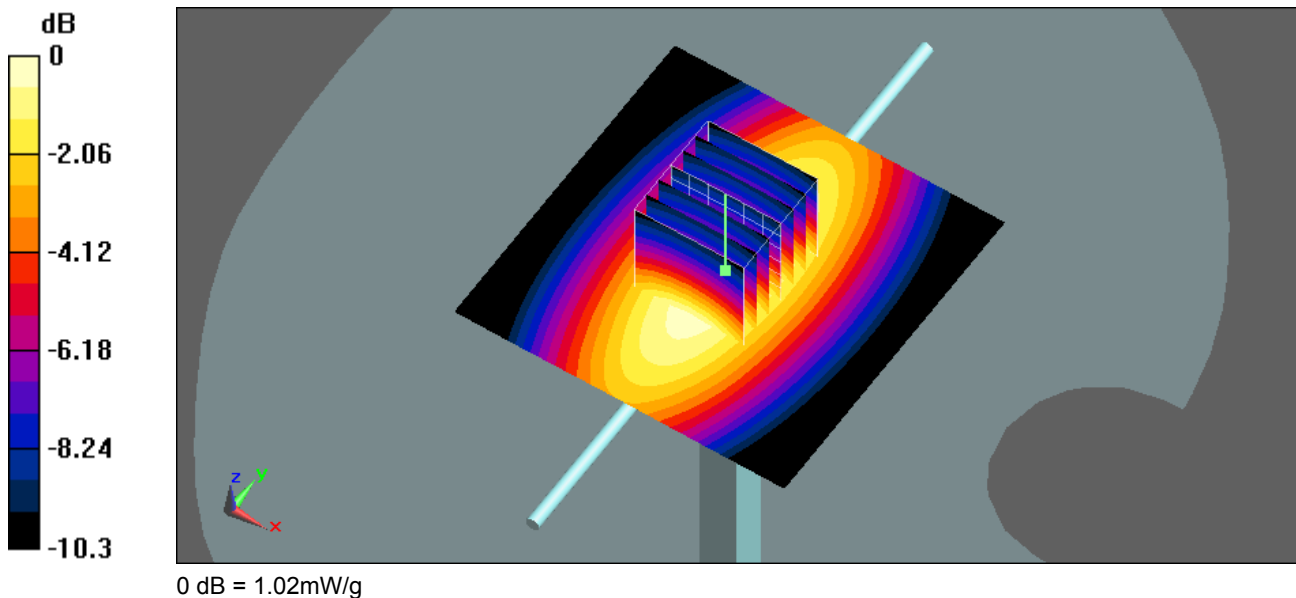

Test Laboratory: Sporton International Inc. SAR/HAC Testing Lab

Date: 2008/11/12

System Check_Head_835MHz_20081112

DUT: Dipole 835 MHz

Communication System: CW; Frequency: 835 MHz; Duty Cycle: 1:1
Medium: HSL_850 Medium parameters used: $f = 835 \text{ MHz}$; $\sigma = 0.902 \text{ mho/m}$; $\epsilon_r = 43.3$; $\rho = 1000 \text{ kg/m}^3$
Ambient Temperature : 22.1 ; Liquid Temperature : 21.2

DASY5 Configuration:

- Probe: ET3DV6 - SN1788; ConvF(6.55, 6.55, 6.55); Calibrated: 2008/9/23
- Sensor-Surface: 4mm (Mechanical Surface Detection)
- Electronics: DAE4 Sn778; Calibrated: 2008/9/22
- Phantom: SAM-Back; Type: QD 000 P40 C; Serial: TP-1383
- Measurement SW: DASY5, V5.0 Build 120; SEMCAD X Version 13.2 Build 87

Pin=100mW/Area Scan (61x61x1): Measurement grid: dx=15mm, dy=15mm
Maximum value of SAR (interpolated) = 0.966 mW/g

Pin=100mW/Zoom Scan (7x7x7)/Cube 0: Measurement grid: dx=5mm, dy=5mm, dz=5mm
Reference Value = 33.8 V/m; Power Drift = -0.00638 dB
Peak SAR (extrapolated) = 1.25 W/kg
SAR(1 g) = 0.899 mW/g; SAR(10 g) = 0.597 mW/g
Maximum value of SAR (measured) = 0.976 mW/g

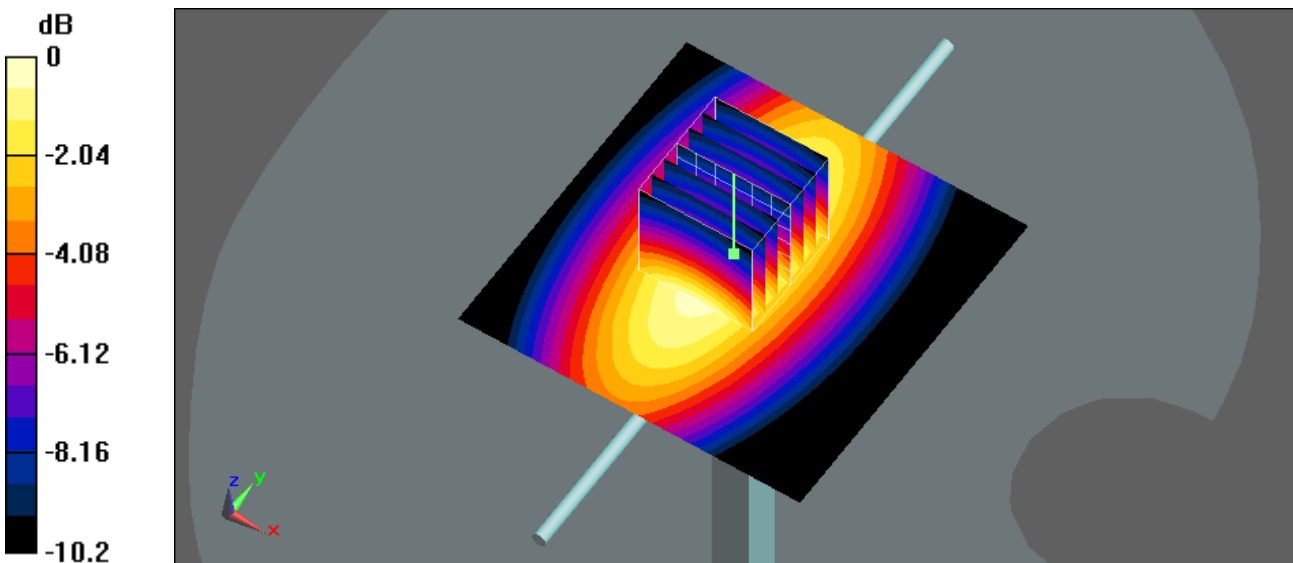

0 dB = 0.976mW/g

Test Laboratory: Sporton International Inc. SAR/HAC Testing Lab

Date: 2008/11/9

System Check_Body_835MHz_20081109

DUT: Dipole 835 MHz

Communication System: CW; Frequency: 835 MHz; Duty Cycle: 1:1
Medium: MSL_850 Medium parameters used: $f = 835 \text{ MHz}$; $\sigma = 0.953 \text{ mho/m}$; $\epsilon_r = 52.6$; $\rho = 1000 \text{ kg/m}^3$
Ambient Temperature : 22.5 ; Liquid Temperature : 21.3

DASY5 Configuration:

- Probe: ET3DV6 - SN1788; ConvF(6.34, 6.34, 6.34); Calibrated: 2008/9/23
- Sensor-Surface: 4mm (Mechanical Surface Detection)
- Electronics: DAE4 Sn778; Calibrated: 2008/9/22
- Phantom: SAM - Front; Type: SAM; Serial: TP-1446
- Measurement SW: DASY5, V5.0 Build 120; SEMCAD X Version 13.2 Build 87

Pin=100mW/Area Scan (61x61x1): Measurement grid: $dx=15\text{mm}$, $dy=15\text{mm}$
Maximum value of SAR (interpolated) = 1.04 mW/g

Pin=100mW/Zoom Scan (7x7x7)/Cube 0: Measurement grid: $dx=5\text{mm}$, $dy=5\text{mm}$, $dz=5\text{mm}$
Reference Value = 34.8 V/m; Power Drift = -0.00939 dB
Peak SAR (extrapolated) = 1.31 W/kg
SAR(1 g) = 0.962 mW/g; SAR(10 g) = 0.642 mW/g
Maximum value of SAR (measured) = 1.05 mW/g

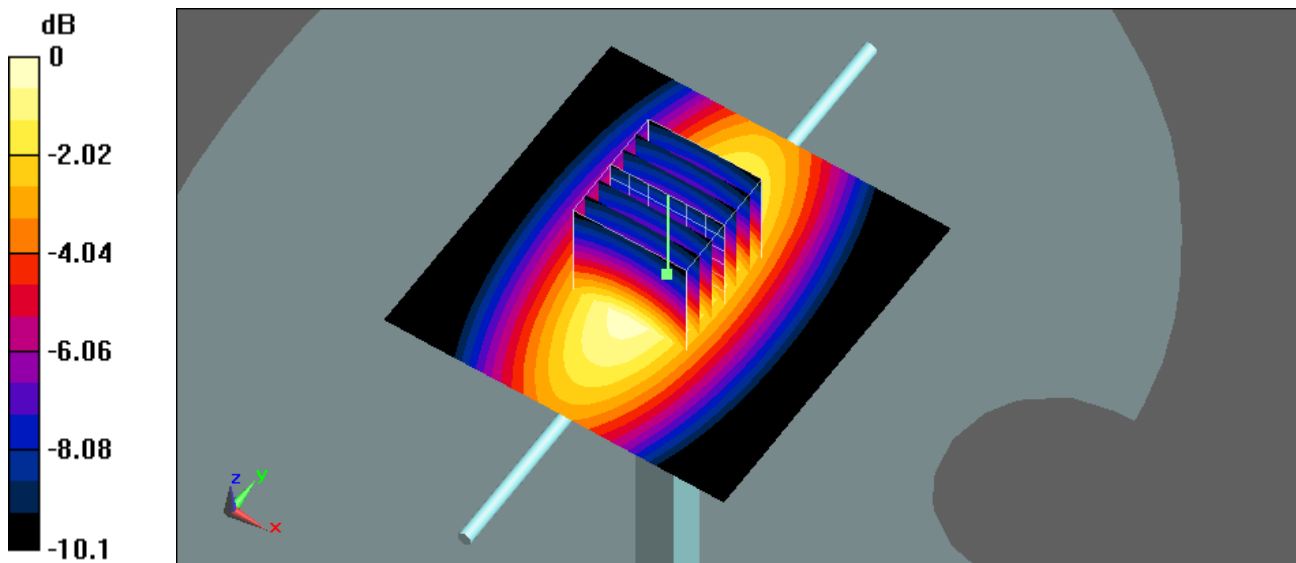

Test Laboratory: Sporton International Inc. SAR/HAC Testing Lab

Date: 2008/11/12

System Check_Body_835MHz_20081112

DUT: Dipole 835 MHz

Communication System: CW; Frequency: 835 MHz; Duty Cycle: 1:1
Medium: MSL_850 Medium parameters used: $f = 835 \text{ MHz}$; $\sigma = 0.957 \text{ mho/m}$; $\epsilon_r = 53$; $\rho = 1000 \text{ kg/m}^3$
Ambient Temperature : 22.4 ; Liquid Temperature : 21.2

DASY5 Configuration:

- Probe: ET3DV6 - SN1788; ConvF(6.34, 6.34, 6.34); Calibrated: 2008/9/23
- Sensor-Surface: 4mm (Mechanical Surface Detection)
- Electronics: DAE4 Sn778; Calibrated: 2008/9/22
- Phantom: SAM-Back; Type: QD 000 P40 C; Serial: TP-1383
- Measurement SW: DASY5, V5.0 Build 120; SEMCAD X Version 13.2 Build 87

Pin=100mW/Area Scan (61x61x1): Measurement grid: dx=15mm, dy=15mm
Maximum value of SAR (interpolated) = 0.965 mW/g

Pin=100mW/Zoom Scan (7x7x7)/Cube 0: Measurement grid: dx=5mm, dy=5mm, dz=5mm
Reference Value = 33.4 V/m; Power Drift = -0.038 dB
Peak SAR (extrapolated) = 1.2 W/kg
SAR(1 g) = 0.883 mW/g; SAR(10 g) = 0.587 mW/g
Maximum value of SAR (measured) = 0.962 mW/g

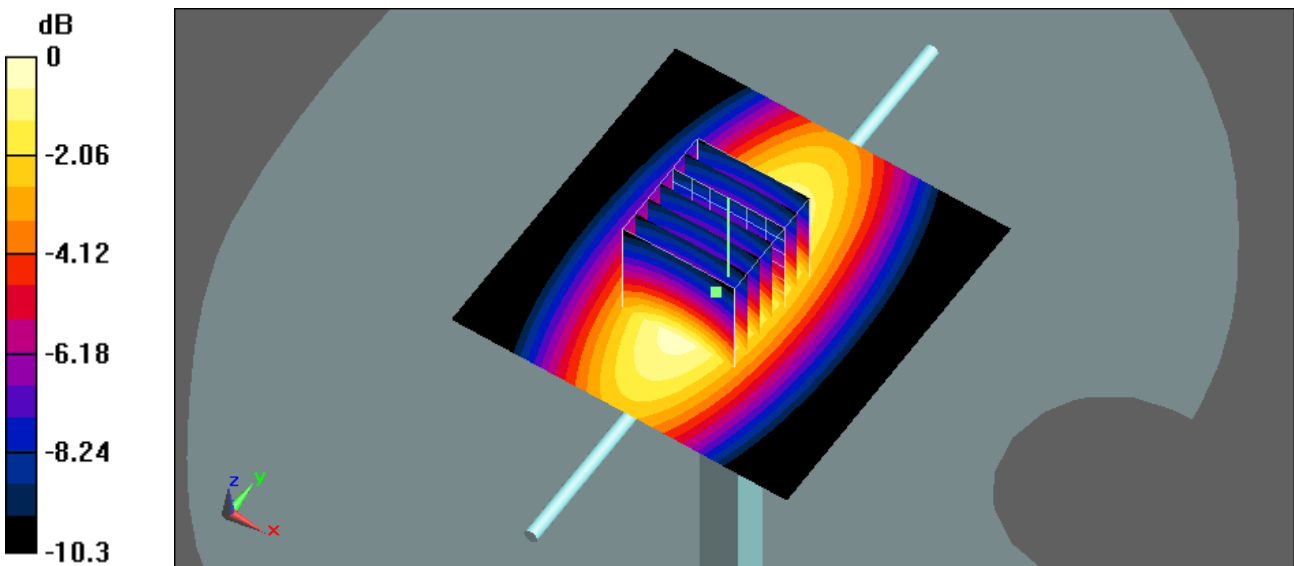

0 dB = 0.962mW/g



Test Laboratory: Sporton International Inc. SAR/HAC Testing Lab

Date: 2009/1/15

System Check_Body_835MHz_20090115

DUT: Dipole 835 MHz

Communication System: CW; Frequency: 835 MHz; Duty Cycle: 1:1
Medium: MSL_850 Medium parameters used: $f = 835 \text{ MHz}$; $\sigma = 0.953 \text{ mho/m}$; $\epsilon_r = 52.6$; $\rho = 1000 \text{ kg/m}^3$
Ambient Temperature : 22.7 ; Liquid Temperature : 21.4

DASY5 Configuration:

- Probe: ET3DV6 - SN1788; ConvF(6.34, 6.34, 6.34); Calibrated: 2008/9/23
- Sensor-Surface: 4mm (Mechanical Surface Detection)
- Electronics: DAE4 Sn778; Calibrated: 2008/9/22
- Phantom: SAM-Back; Type: QD 000 P40 C; Serial: TP-1383
- Measurement SW: DASY5, V5.0 Build 120; SEMCAD X Version 13.2 Build 87

Pin=100mW/Area Scan (61x61x1): Measurement grid: dx=15mm, dy=15mm
Maximum value of SAR (interpolated) = 1.05 mW/g

Pin=100mW/Zoom Scan (7x7x7)/Cube 0: Measurement grid: dx=5mm, dy=5mm, dz=5mm
Reference Value = 34.9 V/m; Power Drift = -0.000928 dB
Peak SAR (extrapolated) = 1.32 W/kg
SAR(1 g) = 0.971 mW/g; SAR(10 g) = 0.647 mW/g
Maximum value of SAR (measured) = 1.06 mW/g

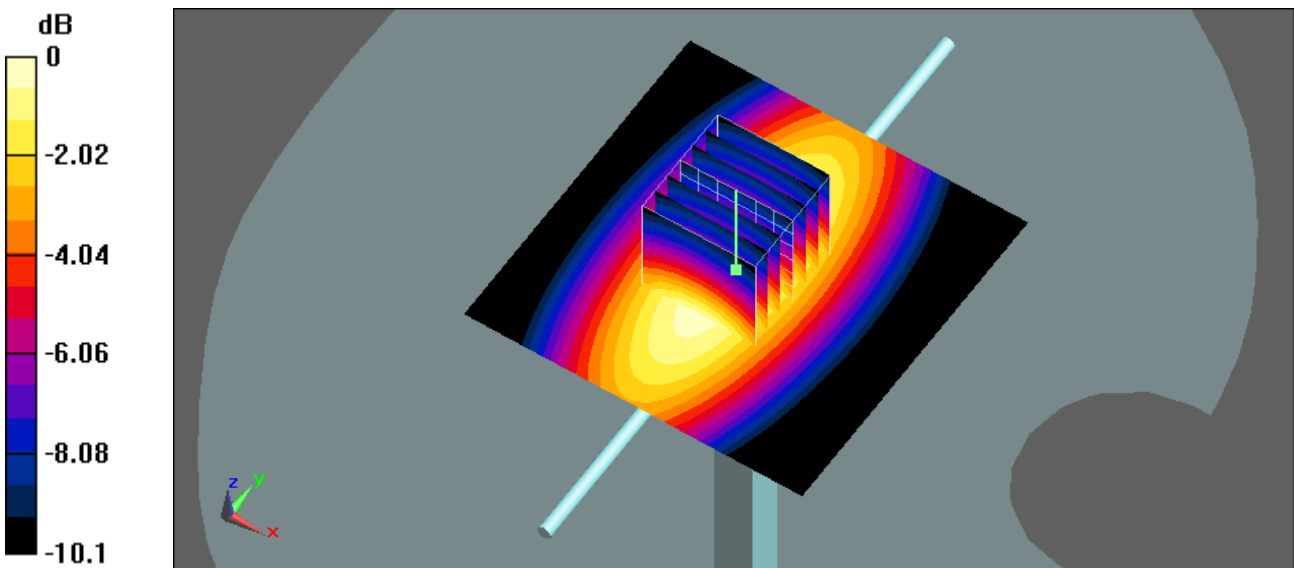

0 dB = 1.06mW/g



Test Laboratory: Sporton International Inc. SAR/HAC Testing Lab

Date: 2008/11/9

System Check_Head_1900MHz_20081109

DUT: Dipole 1900 MHz

Communication System: CW; Frequency: 1900 MHz; Duty Cycle: 1:1
Medium: HSL_1900 Medium parameters used: $f = 1900 \text{ MHz}$; $\sigma = 1.4 \text{ mho/m}$; $\epsilon_r = 41.8$; $\rho = 1000 \text{ kg/m}^3$
Ambient Temperature : 22.5 ; Liquid Temperature : 21.5

DASY5 Configuration:

- Probe: ET3DV6 - SN1788; ConvF(5.13, 5.13, 5.13); Calibrated: 2008/9/23
- Sensor-Surface: 4mm (Mechanical Surface Detection)
- Electronics: DAE4 Sn778; Calibrated: 2008/9/22
- Phantom: SAM-Back; Type: QD 000 P40 C; Serial: TP-1383
- Measurement SW: DASY5, V5.0 Build 120; SEMCAD X Version 13.2 Build 87

Pin=100mW/Area Scan (61x61x1): Measurement grid: $dx=15\text{mm}$, $dy=15\text{mm}$
Maximum value of SAR (interpolated) = 4.39 mW/g

Pin=100mW/Zoom Scan (7x7x7)/Cube 0: Measurement grid: $dx=5\text{mm}$, $dy=5\text{mm}$, $dz=5\text{mm}$
Reference Value = 57 V/m; Power Drift = -0.015 dB
Peak SAR (extrapolated) = 6.93 W/kg
SAR(1 g) = 3.74 mW/g; SAR(10 g) = 1.95 mW/g
Maximum value of SAR (measured) = 4.18 mW/g

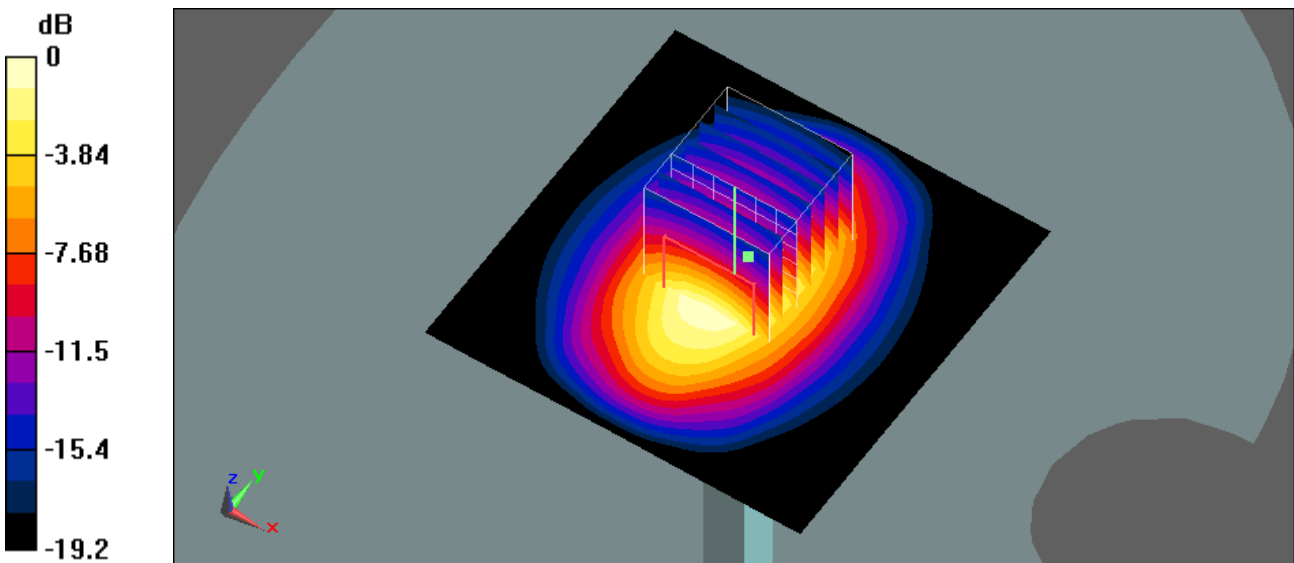

Test Laboratory: Sporton International Inc. SAR/HAC Testing Lab

Date: 2009/1/14

System Check_Head_1900MHz_20090114

DUT: Dipole 1900 MHz

Communication System: CW; Frequency: 1900 MHz; Duty Cycle: 1:1
Medium: HSL_1900 Medium parameters used: $f = 1900 \text{ MHz}$; $\sigma = 1.46 \text{ mho/m}$; $\epsilon_r = 38$; $\rho = 1000 \text{ kg/m}^3$
Ambient Temperature : 22.3 ; Liquid Temperature : 21.5

DASY5 Configuration:

- Probe: ET3DV6 - SN1788; ConvF(5.13, 5.13, 5.13); Calibrated: 2008/9/23
- Sensor-Surface: 4mm (Mechanical Surface Detection)
- Electronics: DAE4 Sn778; Calibrated: 2008/9/22
- Phantom: SAM - Front; Type: SAM; Serial: TP-1446
- Measurement SW: DASY5, V5.0 Build 120; SEMCAD X Version 13.2 Build 87

Pin=100mW/Area Scan (61x61x1): Measurement grid: $dx=15\text{mm}$, $dy=15\text{mm}$
Maximum value of SAR (interpolated) = 4.59 mW/g

Pin=100mW/Zoom Scan (7x7x7)/Cube 0: Measurement grid: $dx=5\text{mm}$, $dy=5\text{mm}$, $dz=5\text{mm}$
Reference Value = 57 V/m; Power Drift = -0.035 dB
Peak SAR (extrapolated) = 7.3 W/kg
SAR(1 g) = 3.93 mW/g; SAR(10 g) = 2.04 mW/g
Maximum value of SAR (measured) = 4.42 mW/g

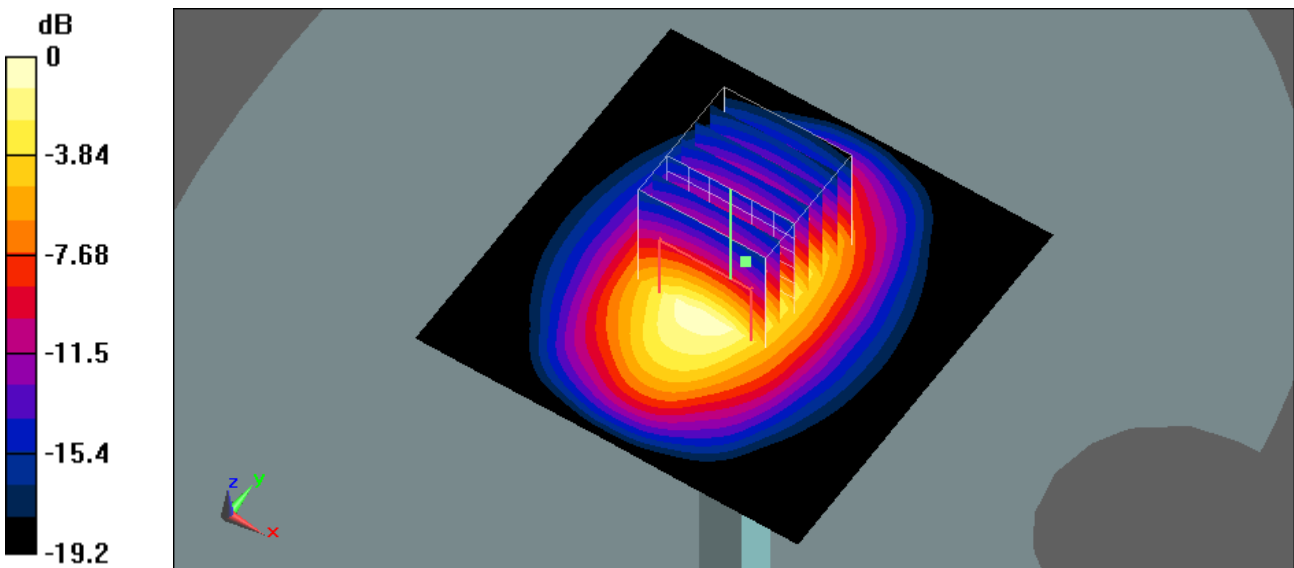

0 dB = 4.42mW/g

Test Laboratory: Sporton International Inc. SAR/HAC Testing Lab

Date: 2008/11/9

System Check_Body_1900MHz_20081109

DUT: Dipole 1900 MHz

Communication System: CW; Frequency: 1900 MHz; Duty Cycle: 1:1
 Medium: MSL_1900 Medium parameters used: $f = 1900 \text{ MHz}$; $\sigma = 1.53 \text{ mho/m}$; $\epsilon_r = 51$; $\rho = 1000 \text{ kg/m}^3$
 Ambient Temperature : 22.4 ; Liquid Temperature : 21.6

DASY5 Configuration:

- Probe: ET3DV6 - SN1788; ConvF(4.73, 4.73, 4.73); Calibrated: 2008/9/23
- Sensor-Surface: 4mm (Mechanical Surface Detection)
- Electronics: DAE4 Sn778; Calibrated: 2008/9/22
- Phantom: SAM-Back; Type: QD 000 P40 C; Serial: TP-1383
- Measurement SW: DASY5, V5.0 Build 120; SEMCAD X Version 13.2 Build 87

Pin=100mW/Area Scan (91x91x1): Measurement grid: $dx=10\text{mm}$, $dy=10\text{mm}$
 Maximum value of SAR (interpolated) = 4.83 mW/g

Pin=100mW/Zoom Scan (7x7x7)/Cube 0: Measurement grid: $dx=5\text{mm}$, $dy=5\text{mm}$, $dz=5\text{mm}$
 Reference Value = 58.5 V/m; Power Drift = 0.00499 dB
 Peak SAR (extrapolated) = 7.44 W/kg
SAR(1 g) = 4.21 mW/g; SAR(10 g) = 2.23 mW/g
 Maximum value of SAR (measured) = 4.74 mW/g

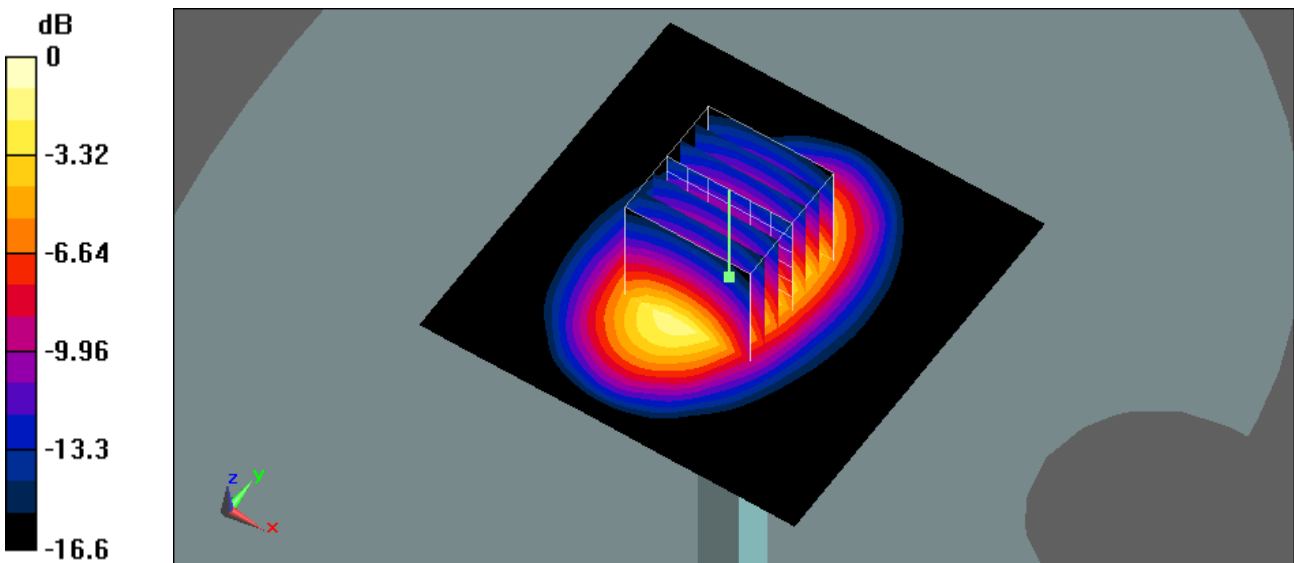

0 dB = 4.74mW/g

Test Laboratory: Sporton International Inc. SAR/HAC Testing Lab

Date: 2008/11/12

System Check_Body_1900MHz_20081112

DUT: Dipole 1900 MHz

Communication System: CW; Frequency: 1900 MHz; Duty Cycle: 1:1
 Medium: MSL_1900 Medium parameters used: $f = 1900 \text{ MHz}$; $\sigma = 1.53 \text{ mho/m}$; $\epsilon_r = 51$; $\rho = 1000 \text{ kg/m}^3$
 Ambient Temperature : 22.5 ; Liquid Temperature : 21.4

DASY5 Configuration:

- Probe: ET3DV6 - SN1788; ConvF(4.73, 4.73, 4.73); Calibrated: 2008/9/23
- Sensor-Surface: 4mm (Mechanical Surface Detection)
- Electronics: DAE4 Sn778; Calibrated: 2008/9/22
- Phantom: SAM-Back; Type: QD 000 P40 C; Serial: TP-1383
- Measurement SW: DASY5, V5.0 Build 120; SEMCAD X Version 13.2 Build 87

Pin=100mW/Area Scan (91x91x1): Measurement grid: dx=10mm, dy=10mm
 Maximum value of SAR (interpolated) = 4.48 mW/g

Pin=100mW/Zoom Scan (7x7x7)/Cube 0: Measurement grid: dx=5mm, dy=5mm, dz=5mm
 Reference Value = 56 V/m; Power Drift = 0.018 dB
 Peak SAR (extrapolated) = 6.84 W/kg
SAR(1 g) = 3.85 mW/g; SAR(10 g) = 2.01 mW/g
 Maximum value of SAR (measured) = 4.36 mW/g

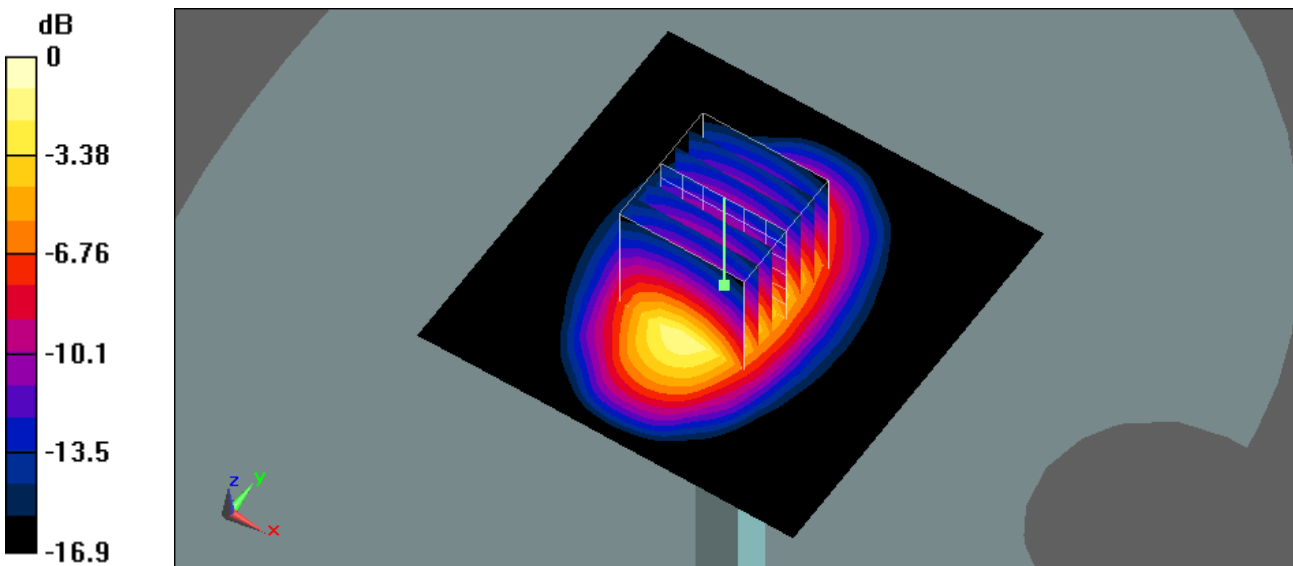

0 dB = 4.36mW/g

Test Laboratory: Sporton International Inc. SAR/HAC Testing Lab

Date: 2009/1/14

System Check_Body_1900MHz_20090114

DUT: Dipole 1900 MHz

Communication System: CW; Frequency: 1900 MHz; Duty Cycle: 1:1
Medium: MSL_1900 Medium parameters used: $f = 1900 \text{ MHz}$; $\sigma = 1.57 \text{ mho/m}$; $\epsilon_r = 51.6$; $\rho = 1000 \text{ kg/m}^3$
Ambient Temperature : 22.4 ; Liquid Temperature : 21.4

DASY5 Configuration:

- Probe: ET3DV6 - SN1788; ConvF(4.73, 4.73, 4.73); Calibrated: 2008/9/23
- Sensor-Surface: 4mm (Mechanical Surface Detection)
- Electronics: DAE4 Sn778; Calibrated: 2008/9/22
- Phantom: SAM - Front; Type: SAM; Serial: TP-1446
- Measurement SW: DASY5, V5.0 Build 120; SEMCAD X Version 13.2 Build 87

Pin=100mW/Area Scan (91x91x1): Measurement grid: $dx=10\text{mm}$, $dy=10\text{mm}$
Maximum value of SAR (interpolated) = 4.96 mW/g

Pin=100mW/Zoom Scan (7x7x7)/Cube 0: Measurement grid: $dx=5\text{mm}$, $dy=5\text{mm}$, $dz=5\text{mm}$
Reference Value = 58.5 V/m; Power Drift = 0.00499 dB
Peak SAR (extrapolated) = 7.64 W/kg
SAR(1 g) = 4.32 mW/g; SAR(10 g) = 2.29 mW/g
Maximum value of SAR (measured) = 4.87 mW/g

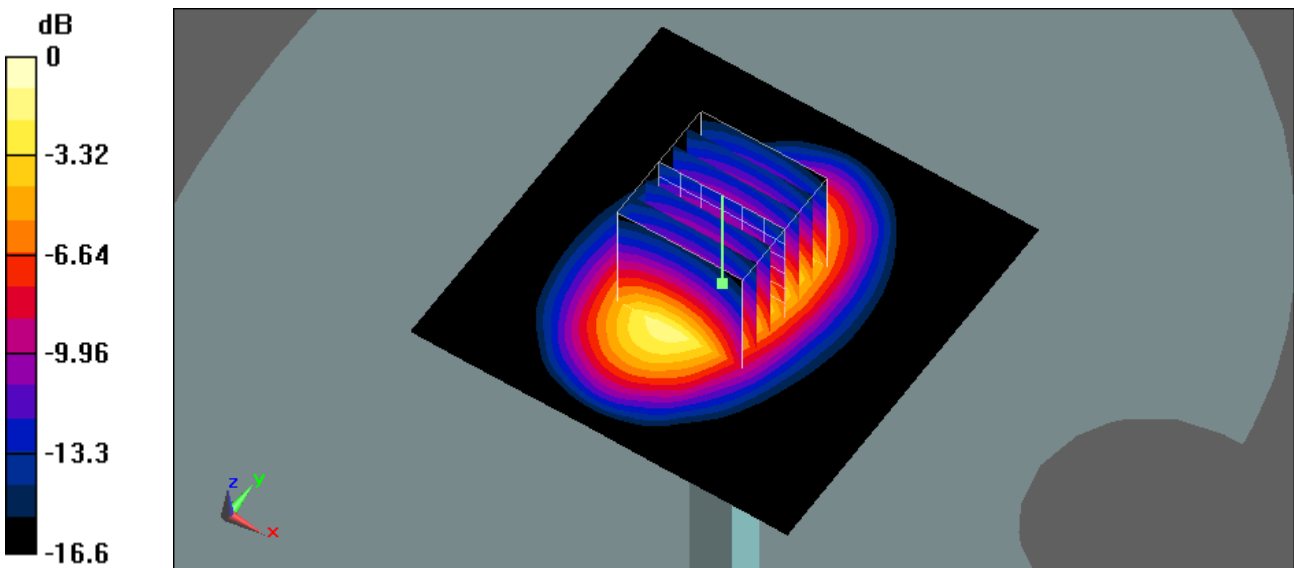

0 dB = 4.87mW/g

Test Laboratory: Sporton International Inc. SAR/HAC Testing Lab

Date: 2008/11/11

System Check_Head_2450Mz_20081111

DUT: Dipole 2450 MHz

Communication System: CW; Frequency: 2450 MHz; Duty Cycle: 1:1
Medium: HSL_2450 Medium parameters used: $f = 2450 \text{ MHz}$; $\sigma = 1.84 \text{ mho/m}$; $\epsilon_r = 37.7$; $\rho = 1000 \text{ kg/m}^3$
Ambient Temperature : 22.6 ; Liquid Temperature : 21.4

DASY5 Configuration:

- Probe: ET3DV6 - SN1788; ConvF(4.68, 4.68, 4.68); Calibrated: 2008/9/23
- Sensor-Surface: 4mm (Mechanical Surface Detection)
- Electronics: DAE4 Sn778; Calibrated: 2008/9/22
- Phantom: SAM-Back; Type: QD 000 P40 C; Serial: TP-1383
- Measurement SW: DASY5, V5.0 Build 120; SEMCAD X Version 13.2 Build 87

Pin=100mW/Area Scan (91x91x1): Measurement grid: $dx=10\text{mm}$, $dy=10\text{mm}$
Maximum value of SAR (interpolated) = 5.98 mW/g

Pin=100mW/Zoom Scan (7x7x7)/Cube 0: Measurement grid: $dx=5\text{mm}$, $dy=5\text{mm}$, $dz=5\text{mm}$
Reference Value = 57.6 V/m; Power Drift = 0.0024 dB
Peak SAR (extrapolated) = 11.7 W/kg

SAR(1 g) = 5.26 mW/g; SAR(10 g) = 2.46 mW/g
Maximum value of SAR (measured) = 5.83 mW/g

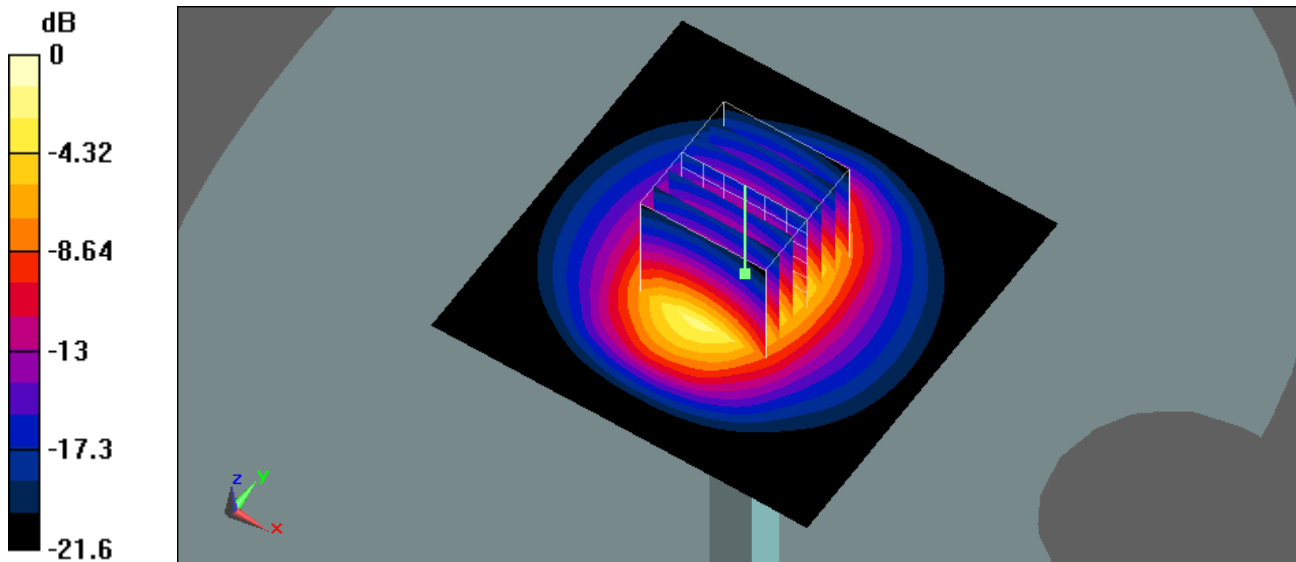

0 dB = 5.83mW/g



Appendix B - SAR Measurement Data

Test Laboratory: Sporton International Inc. SAR/HAC Testing Lab

Date: 2008/11/9

Right Cheek_GSM850 Ch251_2400mA_1D

DUT: 8o2811

Communication System: GSM850; Frequency: 848.8 MHz; Duty Cycle: 1:8.3
Medium: HSL_850 Medium parameters used: $f = 849$ MHz; $\sigma = 0.916$ mho/m; $\epsilon_r = 43.3$; $\rho = 1000$ kg/m³
Ambient Temperature : 22.5 ; Liquid Temperature : 21.4

DASY5 Configuration:

- Probe: ET3DV6 - SN1788; ConvF(6.55, 6.55, 6.55); Calibrated: 2008/9/23
- Sensor-Surface: 4mm (Mechanical Surface Detection)
- Electronics: DAE4 Sn778; Calibrated: 2008/9/22
- Phantom: SAM - Front; Type: SAM; Serial: TP-1446
- Measurement SW: DASY5, V5.0 Build 120; SEMCAD X Version 13.2 Build 87

Ch251/Area Scan (71x111x1): Measurement grid: dx=15mm, dy=15mm
Maximum value of SAR (interpolated) = 1.51 mW/g

Ch251/Zoom Scan (5x5x7)/Cube 0: Measurement grid: dx=8mm, dy=8mm, dz=5mm
Reference Value = 33.4 V/m; Power Drift = 0.039 dB
Peak SAR (extrapolated) = 2.3 W/kg
SAR(1 g) = 1.33 mW/g; SAR(10 g) = 0.852 mW/g
Maximum value of SAR (measured) = 1.45 mW/g

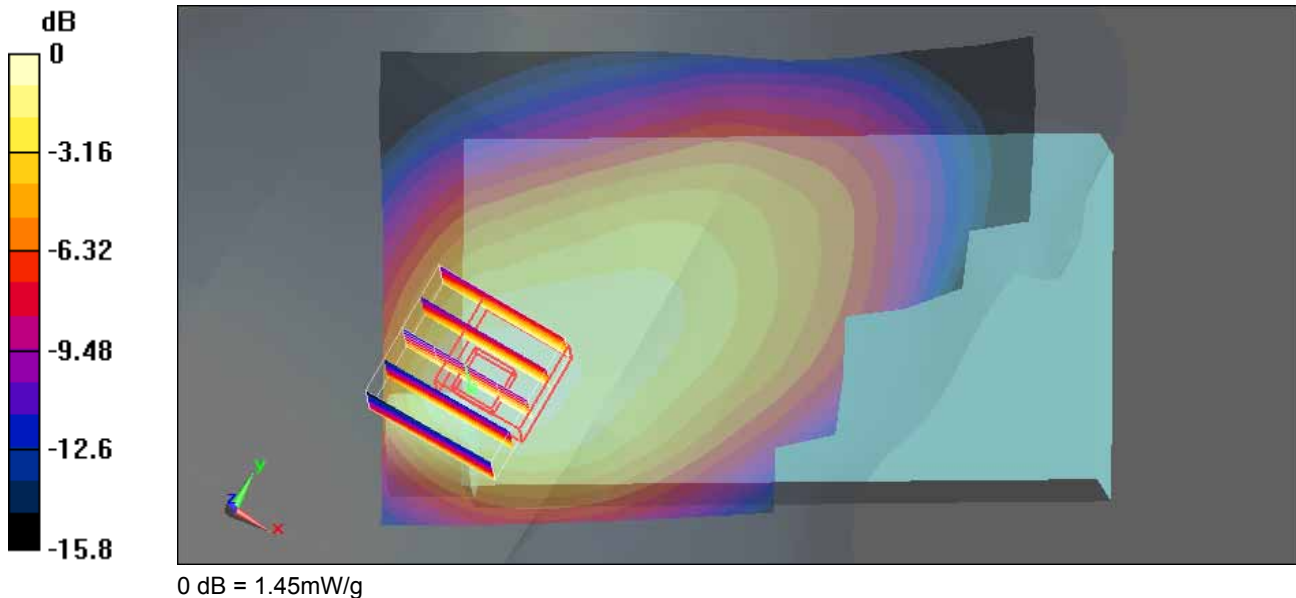

Test Laboratory: Sporton International Inc. SAR/HAC Testing Lab

Date: 2008/11/9

Right Tilted_GSM850 Ch251_2400mA_1D

DUT: 8o2811

Communication System: GSM850; Frequency: 848.8 MHz; Duty Cycle: 1:8.3
Medium: HSL_850 Medium parameters used: $f = 849$ MHz; $\sigma = 0.916$ mho/m; $\epsilon_r = 43.3$; $\rho = 1000$ kg/m³
Ambient Temperature : 22.6 ; Liquid Temperature : 21.4

DASY5 Configuration:

- Probe: ET3DV6 - SN1788; ConvF(6.55, 6.55, 6.55); Calibrated: 2008/9/23
- Sensor-Surface: 4mm (Mechanical Surface Detection)
- Electronics: DAE4 Sn778; Calibrated: 2008/9/22
- Phantom: SAM - Front; Type: SAM; Serial: TP-1446
- Measurement SW: DASY5, V5.0 Build 120; SEMCAD X Version 13.2 Build 87

Ch251/Area Scan (71x111x1): Measurement grid: dx=15mm, dy=15mm
Maximum value of SAR (interpolated) = 1.51 mW/g

Ch251/Zoom Scan (5x5x7)/Cube 0: Measurement grid: dx=8mm, dy=8mm, dz=5mm
Reference Value = 33.3 V/m; Power Drift = 0.00795 dB
Peak SAR (extrapolated) = 2.63 W/kg
SAR(1 g) = 1.3 mW/g; SAR(10 g) = 0.767 mW/g
Maximum value of SAR (measured) = 1.4 mW/g

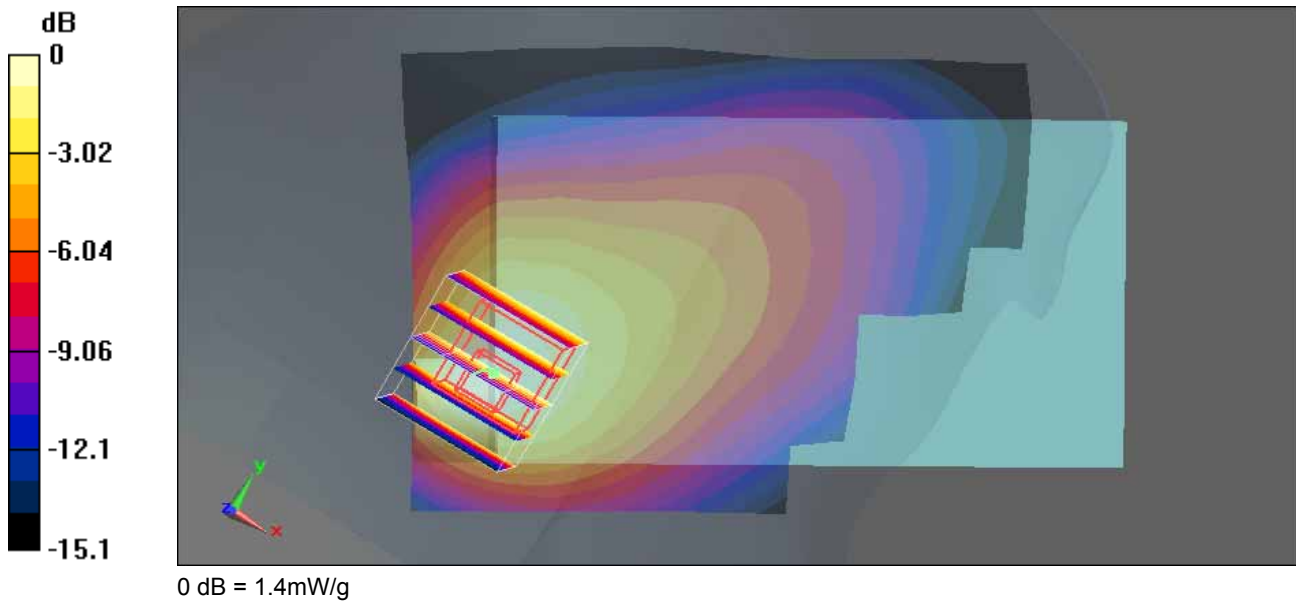

Test Laboratory: Sporton International Inc. SAR/HAC Testing Lab

Date: 2008/11/9

Left Cheek_GSM850 Ch189_2400mA_1D

DUT: 8o2811

Communication System: GSM850; Frequency: 836.4 MHz; Duty Cycle: 1:8.3
Medium: HSL_850 Medium parameters used : $f = 836.4$ MHz; $\sigma = 0.905$ mho/m; $\epsilon_r = 43.4$; $\rho = 1000$ kg/m³
Ambient Temperature : 22.5 ; Liquid Temperature : 21.6

DASY5 Configuration:

- Probe: ET3DV6 - SN1788; ConvF(6.55, 6.55, 6.55); Calibrated: 2008/9/23
- Sensor-Surface: 4mm (Mechanical Surface Detection)
- Electronics: DAE4 Sn778; Calibrated: 2008/9/22
- Phantom: SAM - Front; Type: SAM; Serial: TP-1446
- Measurement SW: DASY5, V5.0 Build 120; SEMCAD X Version 13.2 Build 87

Ch189/Area Scan (71x111x1): Measurement grid: dx=15mm, dy=15mm
Maximum value of SAR (interpolated) = 0.850 mW/g

Ch189/Zoom Scan (5x5x7)/Cube 0: Measurement grid: dx=8mm, dy=8mm, dz=5mm
Reference Value = 30 V/m; Power Drift = -0.052 dB
Peak SAR (extrapolated) = 1.02 W/kg
SAR(1 g) = 0.796 mW/g; SAR(10 g) = 0.587 mW/g
Maximum value of SAR (measured) = 0.840 mW/g

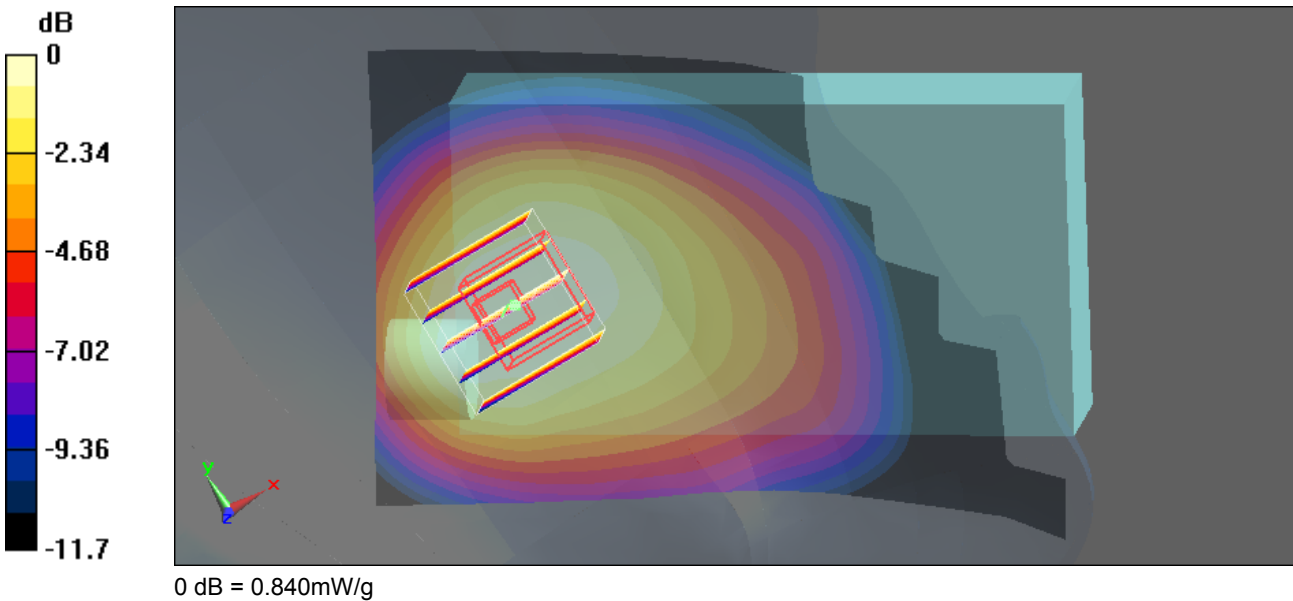

Test Laboratory: Sporton International Inc. SAR/HAC Testing Lab

Date: 2008/11/9

Left Tilted_GSM850 Ch189_2400mA_1D

DUT: 8o2811

Communication System: GSM850; Frequency: 836.4 MHz; Duty Cycle: 1:8.3
Medium: HSL_850 Medium parameters used : $f = 836.4 \text{ MHz}$; $\sigma = 0.905 \text{ mho/m}$; $\epsilon_r = 43.4$; $\rho = 1000 \text{ kg/m}^3$
Ambient Temperature : 22.4 ; Liquid Temperature : 21.6

DASY5 Configuration:

- Probe: ET3DV6 - SN1788; ConvF(6.55, 6.55, 6.55); Calibrated: 2008/9/23
- Sensor-Surface: 4mm (Mechanical Surface Detection)
- Electronics: DAE4 Sn778; Calibrated: 2008/9/22
- Phantom: SAM - Front; Type: SAM; Serial: TP-1446
- Measurement SW: DASY5, V5.0 Build 120; SEMCAD X Version 13.2 Build 87

Ch189/Area Scan (71x111x1): Measurement grid: $dx=15\text{mm}$, $dy=15\text{mm}$
Maximum value of SAR (interpolated) = 0.850 mW/g

Ch189/Zoom Scan (5x5x7)/Cube 0: Measurement grid: $dx=8\text{mm}$, $dy=8\text{mm}$, $dz=5\text{mm}$
Reference Value = 30.5 V/m; Power Drift = 0.00992 dB
Peak SAR (extrapolated) = 1.12 W/kg
SAR(1 g) = 0.743 mW/g; SAR(10 g) = 0.500 mW/g
Maximum value of SAR (measured) = 0.785 mW/g

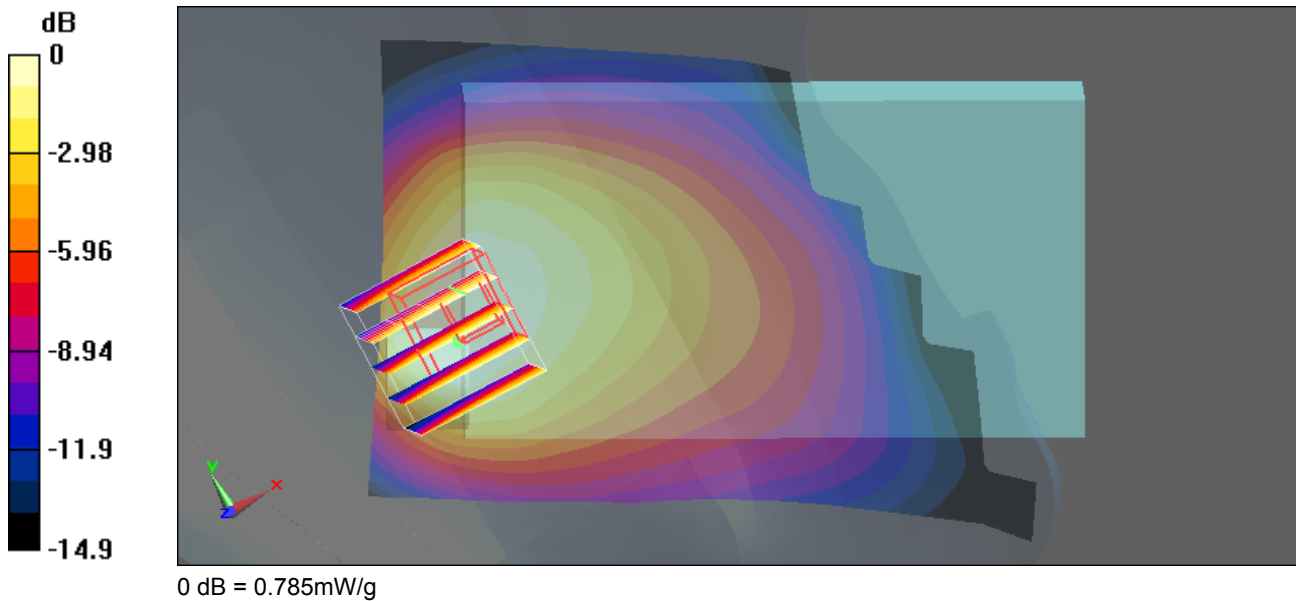



Test Laboratory: Sporton International Inc. SAR/HAC Testing Lab

Date: 2008/11/12

Body_GSM850 Ch251_Face with 1.5cm Gap_GPRS10_2400mA_1D

DUT: 8o2811

Communication System: GSM850; Frequency: 848.8 MHz; Duty Cycle: 1:4
Medium: MSL_850 Medium parameters used: $f = 849$ MHz; $\sigma = 0.971$ mho/m; $\epsilon_r = 52.8$; $\rho = 1000$ kg/m³
Ambient Temperature : 22.4 ; Liquid Temperature : 21.2

DASY5 Configuration:

- Probe: ET3DV6 - SN1788; ConvF(6.34, 6.34, 6.34); Calibrated: 2008/9/23
- Sensor-Surface: 4mm (Mechanical Surface Detection)
- Electronics: DAE4 Sn778; Calibrated: 2008/9/22
- Phantom: SAM-Back; Type: QD 000 P40 C; Serial: TP-1383
- Measurement SW: DASY5, V5.0 Build 120; SEMCAD X Version 13.2 Build 87

Ch251/Area Scan (71x111x1): Measurement grid: dx=15mm, dy=15mm
Maximum value of SAR (interpolated) = 0.409 mW/g

Ch251/Zoom Scan (5x5x7)/Cube 0: Measurement grid: dx=8mm, dy=8mm, dz=5mm
Reference Value = 21.2 V/m; Power Drift = -0.036 dB
Peak SAR (extrapolated) = 0.458 W/kg
SAR(1 g) = 0.387 mW/g; SAR(10 g) = 0.297 mW/g
Maximum value of SAR (measured) = 0.406 mW/g

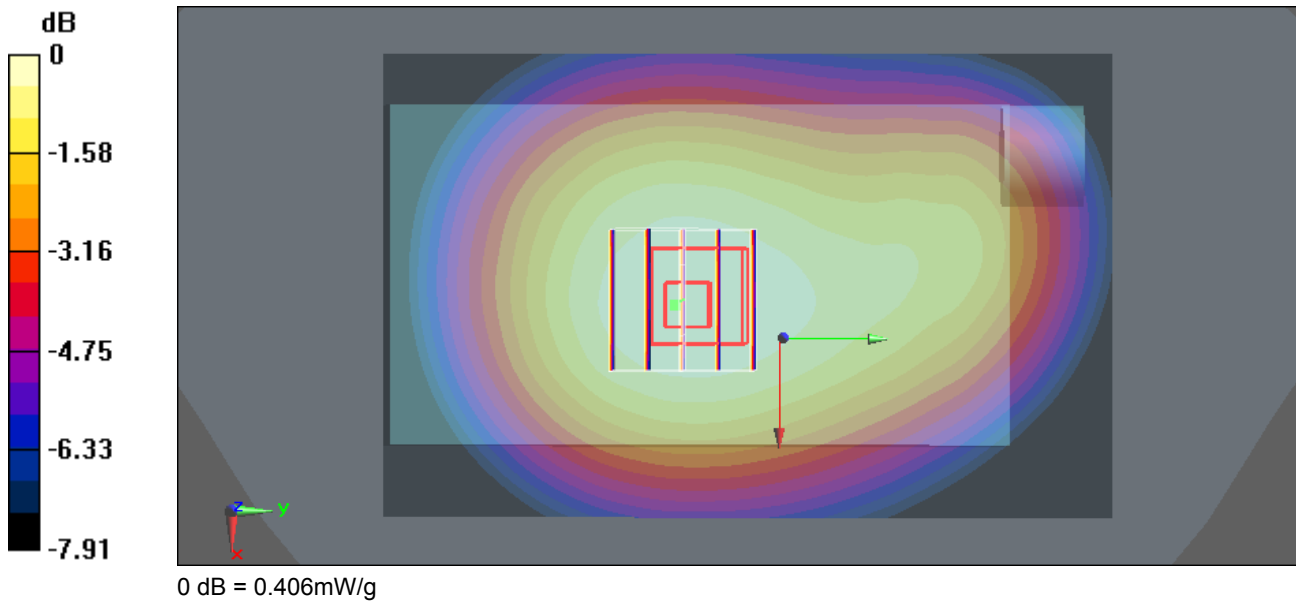



Test Laboratory: Sporton International Inc. SAR/HAC Testing Lab

Date: 2008/11/12

Body_GSM850 Ch189_Bottom with 1.5cm Gap_GPRS12_2400mA_1D

DUT: 8o2811

Communication System: GSM850; Frequency: 836.4 MHz; Duty Cycle: 1:2
Medium: MSL_850 Medium parameters used: $f = 836.4 \text{ MHz}$; $\sigma = 0.958 \text{ mho/m}$; $\epsilon_r = 52.9$; $\rho = 1000 \text{ kg/m}^3$
Ambient Temperature : 22.4 ; Liquid Temperature : 21.2

DASY5 Configuration:

- Probe: ET3DV6 - SN1788; ConvF(6.34, 6.34, 6.34); Calibrated: 2008/9/23
- Sensor-Surface: 4mm (Mechanical Surface Detection)
- Electronics: DAE4 Sn778; Calibrated: 2008/9/22
- Phantom: SAM-Back; Type: QD 000 P40 C; Serial: TP-1383
- Measurement SW: DASY5, V5.0 Build 120; SEMCAD X Version 13.2 Build 87

Ch189/Area Scan (71x111x1): Measurement grid: $dx=15\text{mm}$, $dy=15\text{mm}$
Maximum value of SAR (interpolated) = 0.199 mW/g

Ch189/Zoom Scan (5x5x7)/Cube 0: Measurement grid: $dx=8\text{mm}$, $dy=8\text{mm}$, $dz=5\text{mm}$
Reference Value = 15.2 V/m; Power Drift = -0.190 dB
Peak SAR (extrapolated) = 0.220 W/kg
SAR(1 g) = 0.187 mW/g; SAR(10 g) = 0.144 mW/g
Maximum value of SAR (measured) = 0.196 mW/g

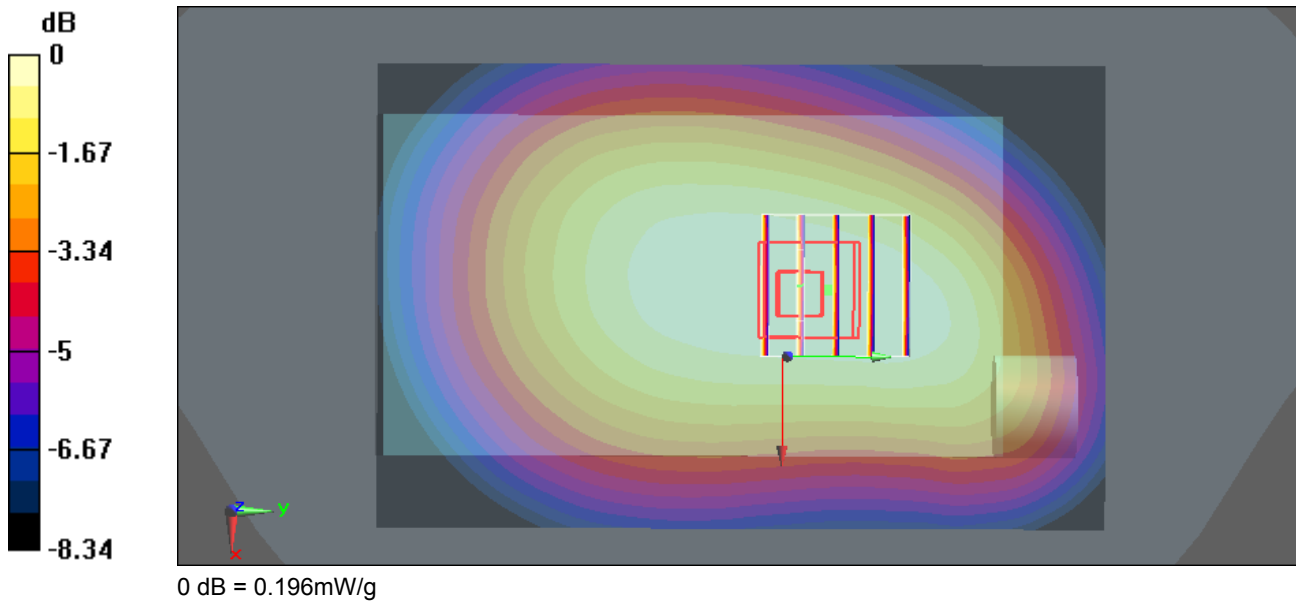



Test Laboratory: Sporton International Inc. SAR/HAC Testing Lab

Date: 2008/11/10

Body_GSM850 Ch251_Face with Holster(1) 0cm Gap_GPRS10_2400mA_1D

DUT: 8o2811

Communication System: GSM850; Frequency: 848.8 MHz; Duty Cycle: 1:4
Medium: MSL_850 Medium parameters used: $f = 849$ MHz; $\sigma = 0.967$ mho/m; $\epsilon_r = 52.5$; $\rho = 1000$ kg/m³
Ambient Temperature : 22.5 ; Liquid Temperature : 21.3

DASY5 Configuration:

- Probe: ET3DV6 - SN1788; ConvF(6.34, 6.34, 6.34); Calibrated: 2008/9/23
- Sensor-Surface: 4mm (Mechanical Surface Detection)
- Electronics: DAE4 Sn778; Calibrated: 2008/9/22
- Phantom: SAM - Front; Type: SAM; Serial: TP-1446
- Measurement SW: DASY5, V5.0 Build 120; SEMCAD X Version 13.2 Build 87

Ch251/Area Scan (71x111x1): Measurement grid: dx=15mm, dy=15mm
Maximum value of SAR (interpolated) = 0.122 mW/g

Ch251/Zoom Scan (5x5x7)/Cube 0: Measurement grid: dx=8mm, dy=8mm, dz=5mm
Reference Value = 11.6 V/m; Power Drift = -0.017 dB
Peak SAR (extrapolated) = 0.137 W/kg
SAR(1 g) = 0.116 mW/g; SAR(10 g) = 0.089 mW/g
Maximum value of SAR (measured) = 0.121 mW/g

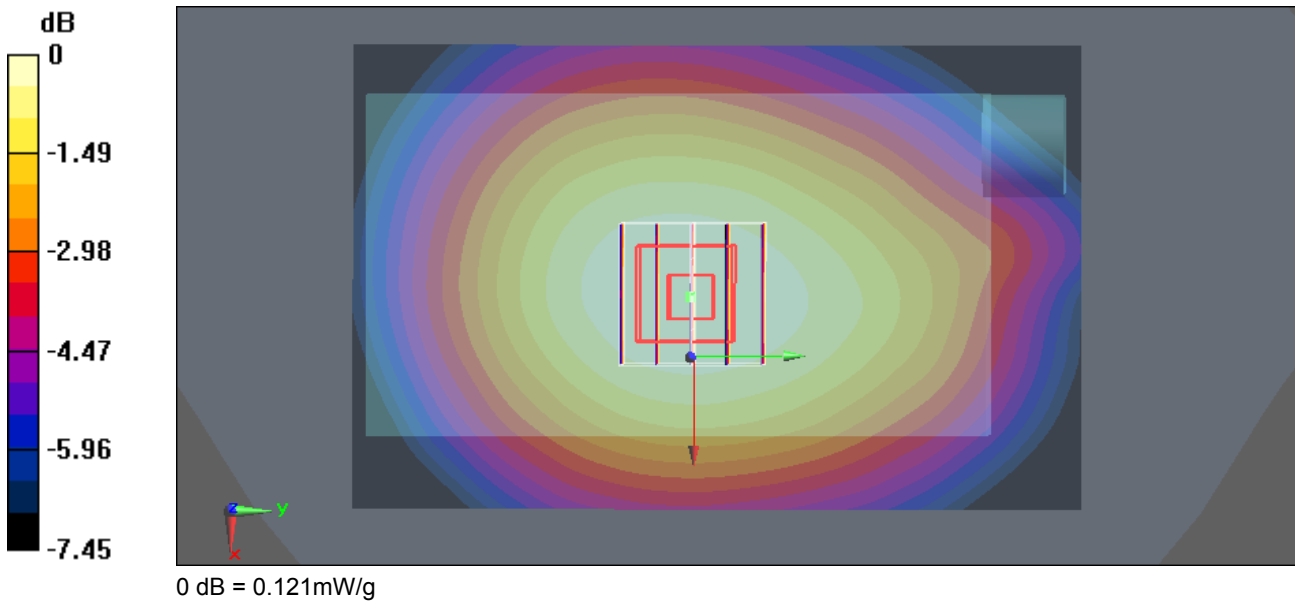



Test Laboratory: Sporton International Inc. SAR/HAC Testing Lab

Date: 2008/11/9

Body_GSM850 Ch189_Bottom with Holster(1) 0cm Gap_GPRS12_2400mA_1D

DUT: 8o2811

Communication System: GSM850; Frequency: 836.4 MHz; Duty Cycle: 1:2
Medium: MSL_850 Medium parameters used: $f = 836.4 \text{ MHz}$; $\sigma = 0.954 \text{ mho/m}$; $\epsilon_r = 52.6$; $\rho = 1000 \text{ kg/m}^3$
Ambient Temperature : 22.4 ; Liquid Temperature : 21.3

DASY5 Configuration:

- Probe: ET3DV6 - SN1788; ConvF(6.34, 6.34, 6.34); Calibrated: 2008/9/23
- Sensor-Surface: 4mm (Mechanical Surface Detection)
- Electronics: DAE4 Sn778; Calibrated: 2008/9/22
- Phantom: SAM - Front; Type: SAM; Serial: TP-1446
- Measurement SW: DASY5, V5.0 Build 120; SEMCAD X Version 13.2 Build 87

Ch189/Area Scan (71x111x1): Measurement grid: $dx=15\text{mm}$, $dy=15\text{mm}$
Maximum value of SAR (interpolated) = 0.089 mW/g

Ch189/Zoom Scan (5x5x7)/Cube 0: Measurement grid: $dx=8\text{mm}$, $dy=8\text{mm}$, $dz=5\text{mm}$
Reference Value = 10.1 V/m; Power Drift = -0.088 dB
Peak SAR (extrapolated) = 0.099 W/kg
SAR(1 g) = 0.083 mW/g; SAR(10 g) = 0.064 mW/g
Maximum value of SAR (measured) = 0.088 mW/g

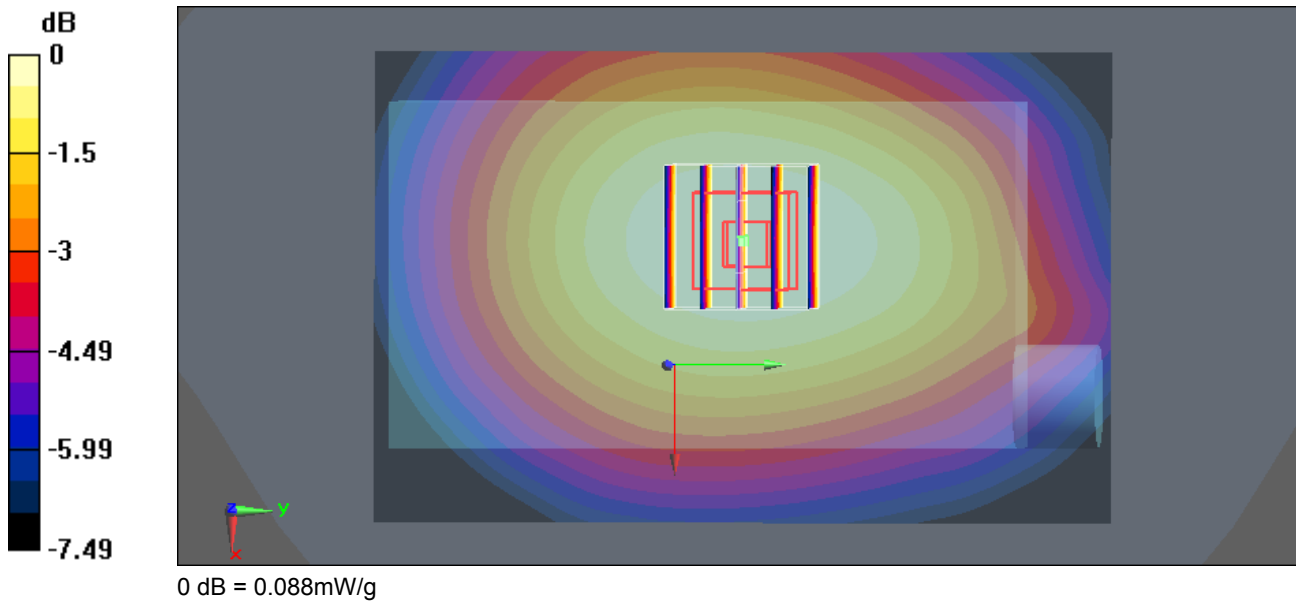



Test Laboratory: Sporton International Inc. SAR/HAC Testing Lab

Date: 2008/11/9

Body_GSM850 Ch251_Face with Holster(2) 0cm Gap_GPRS10_2400mA_1D

DUT: 8o2811

Communication System: GSM850; Frequency: 848.8 MHz; Duty Cycle: 1:4
Medium: MSL_850 Medium parameters used: $f = 849$ MHz; $\sigma = 0.967$ mho/m; $\epsilon_r = 52.5$; $\rho = 1000$ kg/m³
Ambient Temperature : 22.5 ; Liquid Temperature : 21.3

DASY5 Configuration:

- Probe: ET3DV6 - SN1788; ConvF(6.34, 6.34, 6.34); Calibrated: 2008/9/23
- Sensor-Surface: 4mm (Mechanical Surface Detection)
- Electronics: DAE4 Sn778; Calibrated: 2008/9/22
- Phantom: SAM - Front; Type: SAM; Serial: TP-1446
- Measurement SW: DASY5, V5.0 Build 120; SEMCAD X Version 13.2 Build 87

Ch251/Area Scan (71x111x1): Measurement grid: dx=15mm, dy=15mm
Maximum value of SAR (interpolated) = 0.209 mW/g

Ch251/Zoom Scan (5x5x7)/Cube 0: Measurement grid: dx=8mm, dy=8mm, dz=5mm
Reference Value = 15.2 V/m; Power Drift = -0.012 dB
Peak SAR (extrapolated) = 0.235 W/kg
SAR(1 g) = 0.197 mW/g; SAR(10 g) = 0.151 mW/g
Maximum value of SAR (measured) = 0.208 mW/g

Ch251/Zoom Scan (5x5x7)/Cube 1: Measurement grid: dx=8mm, dy=8mm, dz=5mm
Reference Value = 15.2 V/m; Power Drift = -0.012 dB
Peak SAR (extrapolated) = 0.205 W/kg
SAR(1 g) = 0.161 mW/g; SAR(10 g) = 0.117 mW/g
Maximum value of SAR (measured) = 0.175 mW/g

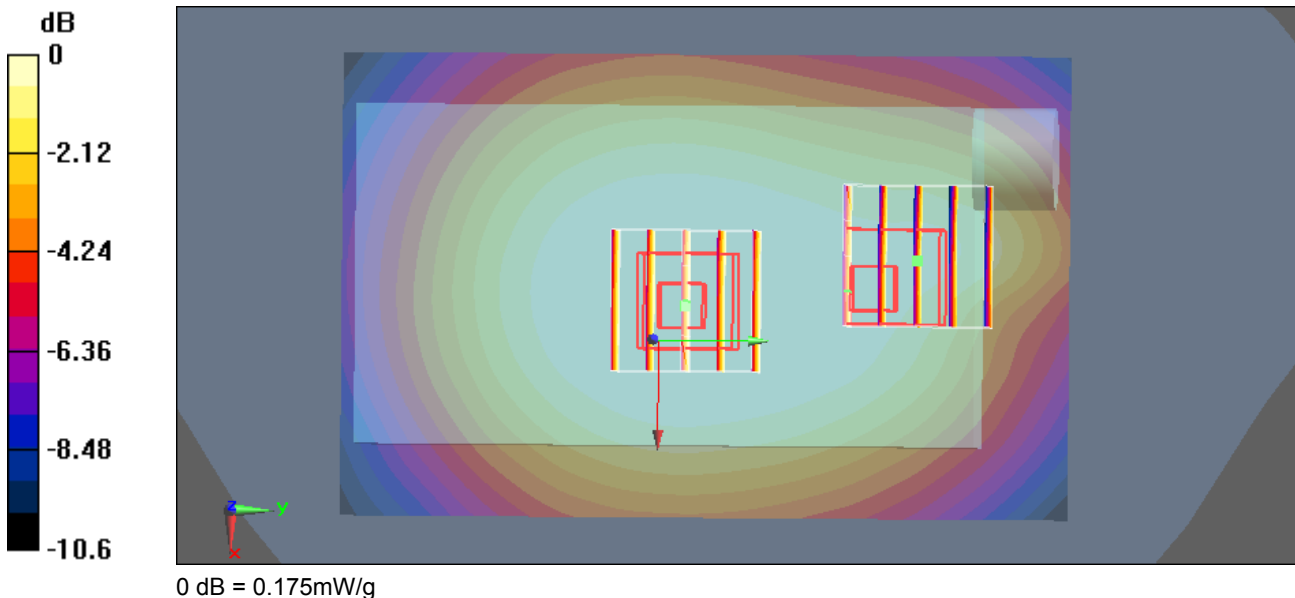

Test Laboratory: Sporton International Inc. SAR/HAC Testing Lab

Date: 2008/11/10

Body_GSM850 Ch251_Face with Holster(3) 0cm Gap_GPRS10_2400mA_1D

DUT: 8o2811

Communication System: GSM850; Frequency: 848.8 MHz; Duty Cycle: 1:4
Medium: MSL_850 Medium parameters used: $f = 849$ MHz; $\sigma = 0.967$ mho/m; $\epsilon_r = 52.5$; $\rho = 1000$ kg/m³
Ambient Temperature : 22.3 ; Liquid Temperature : 21.3

DASY5 Configuration:

- Probe: ET3DV6 - SN1788; ConvF(6.34, 6.34, 6.34); Calibrated: 2008/9/23
- Sensor-Surface: 4mm (Mechanical Surface Detection)
- Electronics: DAE4 Sn778; Calibrated: 2008/9/22
- Phantom: SAM - Front; Type: SAM; Serial: TP-1446
- Measurement SW: DASY5, V5.0 Build 120; SEMCAD X Version 13.2 Build 87

Ch251/Area Scan (71x111x1): Measurement grid: dx=15mm, dy=15mm
Maximum value of SAR (interpolated) = 0.372 mW/g

Ch251/Zoom Scan (5x5x7)/Cube 0: Measurement grid: dx=8mm, dy=8mm, dz=5mm
Reference Value = 19.9 V/m; Power Drift = -0.059 dB
Peak SAR (extrapolated) = 0.419 W/kg
SAR(1 g) = 0.351 mW/g; SAR(10 g) = 0.267 mW/g
Maximum value of SAR (measured) = 0.370 mW/g

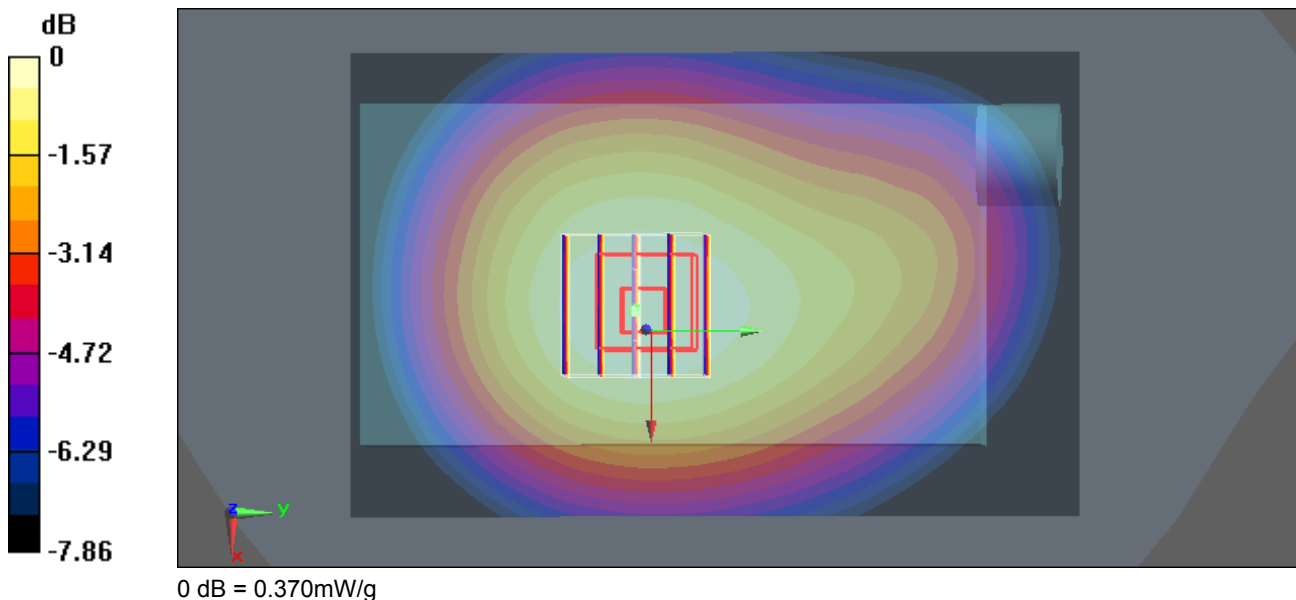



Test Laboratory: Sporton International Inc. SAR/HAC Testing Lab

Date: 2008/11/10

Body_GSM850 Ch189_Bottom with Holster(3) 0cm Gap_GPRS12_2400mA_1D

DUT: 8o2811

Communication System: GSM850; Frequency: 836.4 MHz; Duty Cycle: 1:2
Medium: MSL_850 Medium parameters used: $f = 836.4 \text{ MHz}$; $\sigma = 0.954 \text{ mho/m}$; $\epsilon_r = 52.6$; $\rho = 1000 \text{ kg/m}^3$
Ambient Temperature : 22.5 ; Liquid Temperature : 21.3

DASY5 Configuration:

- Probe: ET3DV6 - SN1788; ConvF(6.34, 6.34, 6.34); Calibrated: 2008/9/23
- Sensor-Surface: 4mm (Mechanical Surface Detection)
- Electronics: DAE4 Sn778; Calibrated: 2008/9/22
- Phantom: SAM - Front; Type: SAM; Serial: TP-1446
- Measurement SW: DASY5, V5.0 Build 120; SEMCAD X Version 13.2 Build 87

Ch189/Area Scan (71x111x1): Measurement grid: $dx=15\text{mm}$, $dy=15\text{mm}$
Maximum value of SAR (interpolated) = 0.166 mW/g

Ch189/Zoom Scan (5x5x7)/Cube 0: Measurement grid: $dx=8\text{mm}$, $dy=8\text{mm}$, $dz=5\text{mm}$
Reference Value = 13.8 V/m; Power Drift = -0.050 dB
Peak SAR (extrapolated) = 0.184 W/kg
SAR(1 g) = 0.157 mW/g; SAR(10 g) = 0.121 mW/g
Maximum value of SAR (measured) = 0.166 mW/g

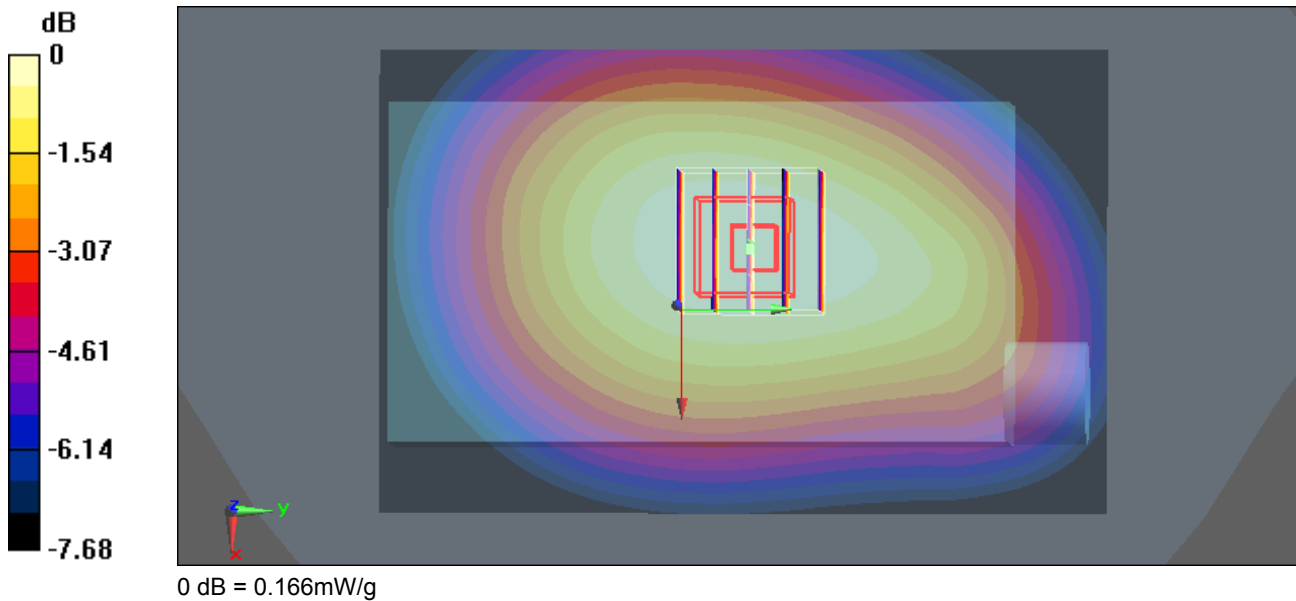

Test Laboratory: Sporton International Inc. SAR/HAC Testing Lab

Date: 2009/1/14

Right Cheek_GSM1900 Ch810_3600mA_2D

DUT: 8o2811

Communication System: PCS; Frequency: 1909.8 MHz; Duty Cycle: 1:8.3
Medium: HSL_1900 Medium parameters used: $f = 1910 \text{ MHz}$; $\sigma = 1.47 \text{ mho/m}$; $\epsilon_r = 38$; $\rho = 1000 \text{ kg/m}^3$
Ambient Temperature : 22.5 ; Liquid Temperature : 21.5

DASY5 Configuration:

- Probe: ET3DV6 - SN1788; ConvF(5.13, 5.13, 5.13); Calibrated: 2008/9/23
- Sensor-Surface: 4mm (Mechanical Surface Detection)
- Electronics: DAE4 Sn778; Calibrated: 2008/9/22
- Phantom: SAM - Front; Type: SAM; Serial: TP-1446
- Measurement SW: DASY5, V5.0 Build 120; SEMCAD X Version 13.2 Build 87

Ch810/Area Scan (71x121x1): Measurement grid: $dx=15\text{mm}$, $dy=15\text{mm}$
Maximum value of SAR (interpolated) = 0.632 mW/g

Ch810/Zoom Scan (5x5x7)/Cube 0: Measurement grid: $dx=8\text{mm}$, $dy=8\text{mm}$, $dz=5\text{mm}$
Reference Value = 14.7 V/m; Power Drift = -0.028 dB
Peak SAR (extrapolated) = 1.000 W/kg
SAR(1 g) = 0.567 mW/g; SAR(10 g) = 0.329 mW/g
Maximum value of SAR (measured) = 0.592 mW/g

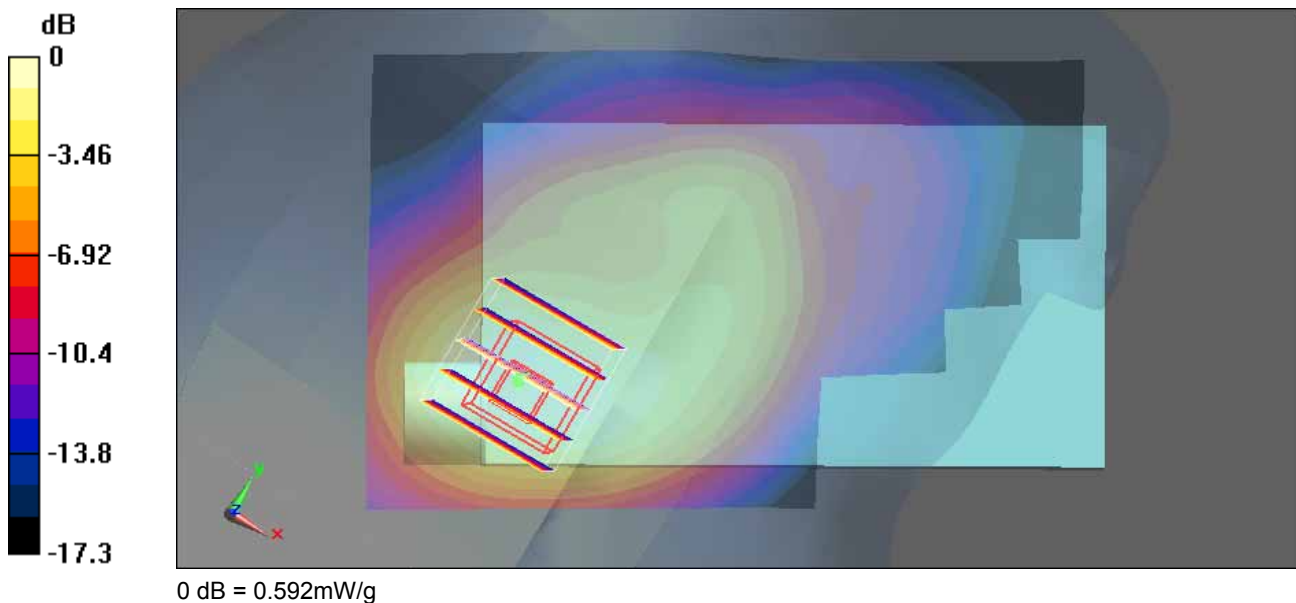



Test Laboratory: Sporton International Inc. SAR/HAC Testing Lab

Date: 2008/11/9

Right Tilted_GSM1900 Ch661_2400mA_1D

DUT: 8o2811

Communication System: PCS; Frequency: 1880 MHz;Duty Cycle: 1:8.3
Medium: HSL_1900 Medium parameters used: f = 1880 MHz; $\sigma = 1.37$ mho/m; $\epsilon_r = 41.8$; $\rho = 1000$ kg/m³
Ambient Temperature : 22.4 ; Liquid Temperature : 21.5

DASY5 Configuration:

- Probe: ET3DV6 - SN1788; ConvF(5.13, 5.13, 5.13); Calibrated: 2008/9/23
- Sensor-Surface: 4mm (Mechanical Surface Detection)
- Electronics: DAE4 Sn778; Calibrated: 2008/9/22
- Phantom: SAM-Back; Type: QD 000 P40 C; Serial: TP-1383
- Measurement SW: DASY5, V5.0 Build 120; SEMCAD X Version 13.2 Build 87

Ch661/Area Scan (71x111x1): Measurement grid: dx=15mm, dy=15mm
Maximum value of SAR (interpolated) = 0.458 mW/g

Ch661/Zoom Scan (5x5x7)/Cube 0: Measurement grid: dx=8mm, dy=8mm, dz=5mm
Reference Value = 15.1 V/m; Power Drift = 0.00721 dB
Peak SAR (extrapolated) = 0.717 W/kg
SAR(1 g) = 0.399 mW/g; SAR(10 g) = 0.227 mW/g
Maximum value of SAR (measured) = 0.434 mW/g

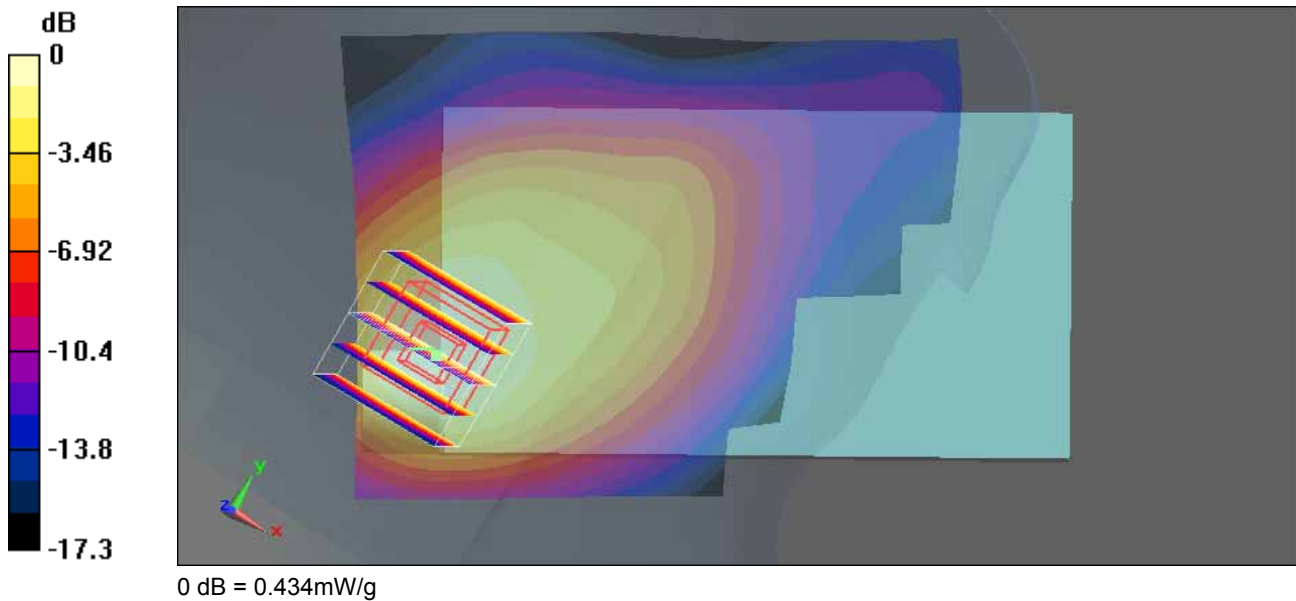



Test Laboratory: Sporton International Inc. SAR/HAC Testing Lab

Date: 2008/11/9

Left Cheek_GSM1900 Ch661_2400mA_1D

DUT: 8o2811

Communication System: PCS; Frequency: 1880 MHz;Duty Cycle: 1:8.3
Medium: HSL_1900 Medium parameters used: $f = 1880 \text{ MHz}$; $\sigma = 1.37 \text{ mho/m}$; $\epsilon_r = 41.8$; $\rho = 1000 \text{ kg/m}^3$
Ambient Temperature : 22.4 ; Liquid Temperature : 21.5

DASY5 Configuration:

- Probe: ET3DV6 - SN1788; ConvF(5.13, 5.13, 5.13); Calibrated: 2008/9/23
- Sensor-Surface: 4mm (Mechanical Surface Detection)
- Electronics: DAE4 Sn778; Calibrated: 2008/9/22
- Phantom: SAM-Back; Type: QD 000 P40 C; Serial: TP-1383
- Measurement SW: DASY5, V5.0 Build 120; SEMCAD X Version 13.2 Build 87

Ch661/Area Scan (71x111x1): Measurement grid: $dx=15\text{mm}$, $dy=15\text{mm}$
Maximum value of SAR (interpolated) = 0.358 mW/g

Ch661/Zoom Scan (5x5x7)/Cube 0: Measurement grid: $dx=8\text{mm}$, $dy=8\text{mm}$, $dz=5\text{mm}$
Reference Value = 15 V/m; Power Drift = -0.063 dB
Peak SAR (extrapolated) = 0.471 W/kg
SAR(1 g) = 0.304 mW/g; SAR(10 g) = 0.200 mW/g
Maximum value of SAR (measured) = 0.320 mW/g

Ch661/Zoom Scan (5x5x7)/Cube 1: Measurement grid: $dx=8\text{mm}$, $dy=8\text{mm}$, $dz=5\text{mm}$
Reference Value = 15 V/m; Power Drift = -0.063 dB
Peak SAR (extrapolated) = 0.469 W/kg
SAR(1 g) = 0.289 mW/g; SAR(10 g) = 0.181 mW/g
Maximum value of SAR (measured) = 0.317 mW/g

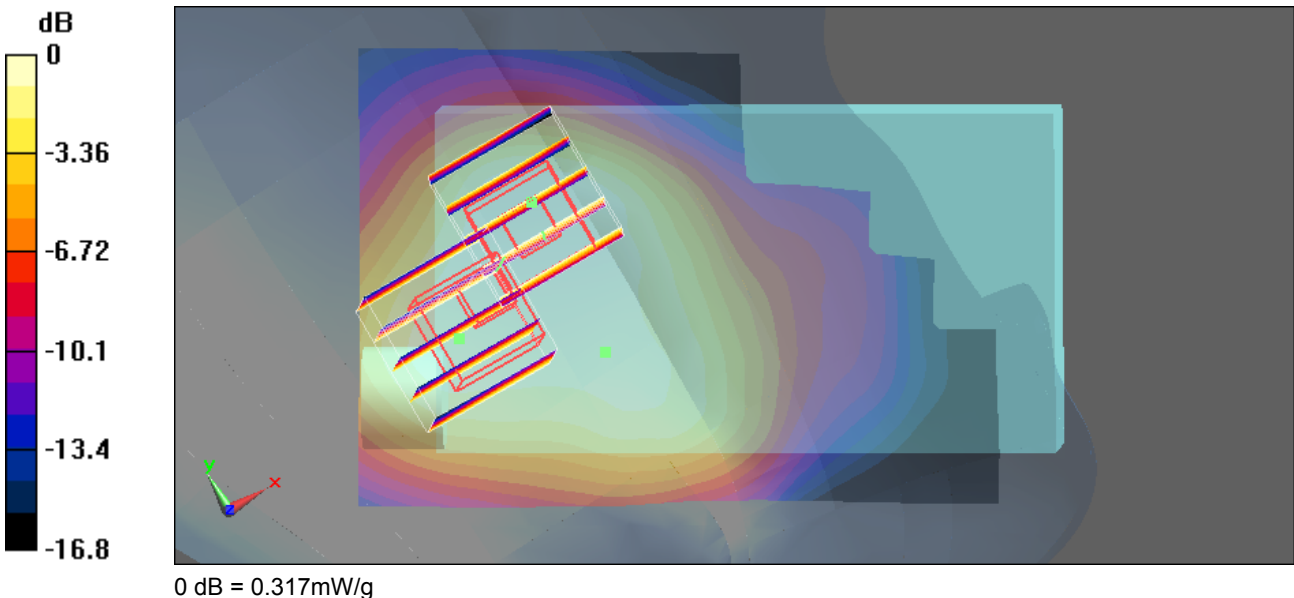

Test Laboratory: Sporton International Inc. SAR/HAC Testing Lab

Date: 2008/11/9

Left Tilted_GSM1900 Ch661_2400mA_1D

DUT: 8o2811

Communication System: PCS; Frequency: 1880 MHz; Duty Cycle: 1:8.3
Medium: HSL_1900 Medium parameters used: $f = 1880 \text{ MHz}$; $\sigma = 1.37 \text{ mho/m}$; $\epsilon_r = 41.8$; $\rho = 1000 \text{ kg/m}^3$
Ambient Temperature : 22.4 ; Liquid Temperature : 21.5

DASY5 Configuration:

- Probe: ET3DV6 - SN1788; ConvF(5.13, 5.13, 5.13); Calibrated: 2008/9/23
- Sensor-Surface: 4mm (Mechanical Surface Detection)
- Electronics: DAE4 Sn778; Calibrated: 2008/9/22
- Phantom: SAM-Back; Type: QD 000 P40 C; Serial: TP-1383
- Measurement SW: DASY5, V5.0 Build 120; SEMCAD X Version 13.2 Build 87

Ch661/Area Scan (71x111x1): Measurement grid: $dx=15\text{mm}$, $dy=15\text{mm}$
Maximum value of SAR (interpolated) = 0.330 mW/g

Ch661/Zoom Scan (5x5x7)/Cube 0: Measurement grid: $dx=8\text{mm}$, $dy=8\text{mm}$, $dz=5\text{mm}$
Reference Value = 16.1 V/m; Power Drift = -0.039 dB
Peak SAR (extrapolated) = 0.496 W/kg
SAR(1 g) = 0.306 mW/g; SAR(10 g) = 0.190 mW/g
Maximum value of SAR (measured) = 0.328 mW/g

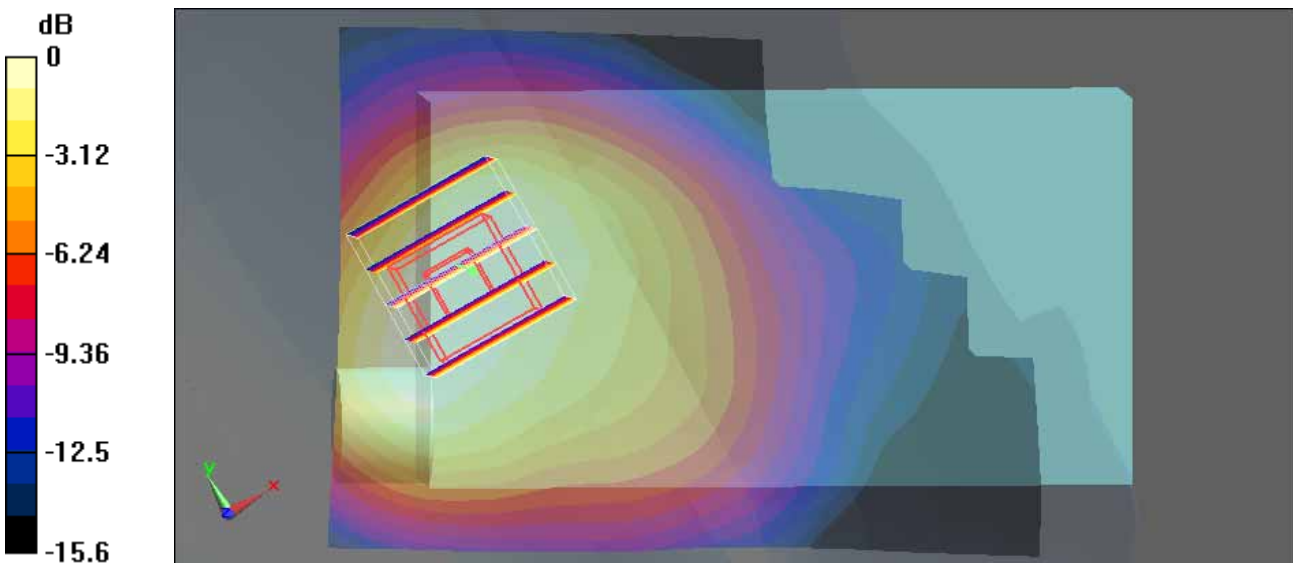

0 dB = 0.328mW/g

Test Laboratory: Sporton International Inc. SAR/HAC Testing Lab

Date: 2008/11/12

Body_GSM1900 Ch661_Face with 1.5cm Gap_GPRS12_2400mA_1D_#0303

DUT: 8o2811

Communication System: PCS; Frequency: 1880 MHz;Duty Cycle: 1:2
Medium: MSL_1900 Medium parameters used: $f = 1880 \text{ MHz}$; $\sigma = 1.51 \text{ mho/m}$; $\epsilon_r = 51$; $\rho = 1000 \text{ kg/m}^3$
Ambient Temperature : 22.5 ; Liquid Temperature : 21.4

DASY5 Configuration:

- Probe: ET3DV6 - SN1788; ConvF(4.73, 4.73, 4.73); Calibrated: 2008/9/23
- Sensor-Surface: 4mm (Mechanical Surface Detection)
- Electronics: DAE4 Sn778; Calibrated: 2008/9/22
- Phantom: SAM-Back; Type: QD 000 P40 C; Serial: TP-1383
- Measurement SW: DASY5, V5.0 Build 120; SEMCAD X Version 13.2 Build 87

Ch661/Area Scan (71x111x1): Measurement grid: $dx=15\text{mm}$, $dy=15\text{mm}$
Maximum value of SAR (interpolated) = 0.158 mW/g

Ch661/Zoom Scan (5x5x7)/Cube 0: Measurement grid: $dx=8\text{mm}$, $dy=8\text{mm}$, $dz=5\text{mm}$
Reference Value = 8.29 V/m; Power Drift = -0.161 dB
Peak SAR (extrapolated) = 0.221 W/kg
SAR(1 g) = 0.147 mW/g; SAR(10 g) = 0.098 mW/g
Maximum value of SAR (measured) = 0.157 mW/g

Ch661/Zoom Scan (5x5x7)/Cube 1: Measurement grid: $dx=8\text{mm}$, $dy=8\text{mm}$, $dz=5\text{mm}$
Reference Value = 8.29 V/m; Power Drift = -0.161 dB
Peak SAR (extrapolated) = 0.177 W/kg
SAR(1 g) = 0.111 mW/g; SAR(10 g) = 0.071 mW/g
Maximum value of SAR (measured) = 0.119 mW/g

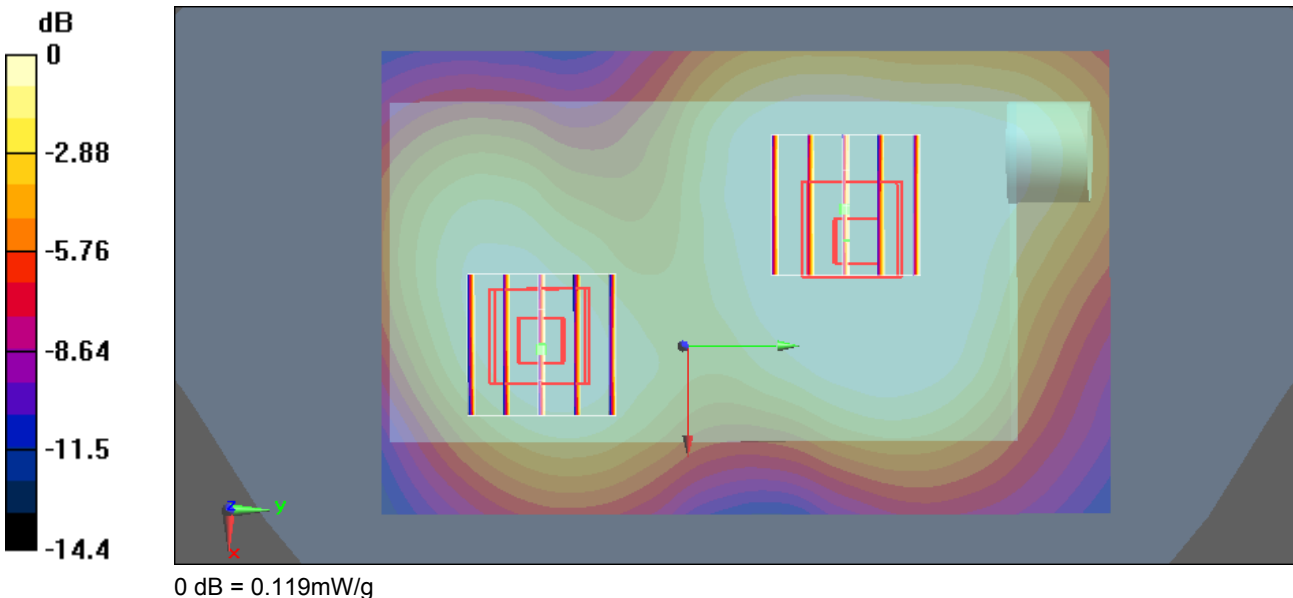

Test Laboratory: Sporton International Inc. SAR/HAC Testing Lab

Date: 2008/11/12

Body_GSM1900 Ch512_Bottom with 1.5cm Gap_GPRS10_2400mA_1D

DUT: 8o2811

Communication System: PCS; Frequency: 1850.2 MHz; Duty Cycle: 1:4
Medium: MSL_1900 Medium parameters used : $f = 1850.2$ MHz; $\sigma = 1.48$ mho/m; $\epsilon_r = 51.1$; $\rho = 1000$ kg/m³
Ambient Temperature : 22.5 ; Liquid Temperature : 21.4

DASY5 Configuration:

- Probe: ET3DV6 - SN1788; ConvF(4.73, 4.73, 4.73); Calibrated: 2008/9/23
- Sensor-Surface: 4mm (Mechanical Surface Detection)
- Electronics: DAE4 Sn778; Calibrated: 2008/9/22
- Phantom: SAM-Back; Type: QD 000 P40 C; Serial: TP-1383
- Measurement SW: DASY5, V5.0 Build 120; SEMCAD X Version 13.2 Build 87

Ch512/Area Scan (71x111x1): Measurement grid: dx=15mm, dy=15mm
Maximum value of SAR (interpolated) = 0.258 mW/g

Ch512/Zoom Scan (5x5x7)/Cube 0: Measurement grid: dx=8mm, dy=8mm, dz=5mm
Reference Value = 8.56 V/m; Power Drift = -0.109 dB
Peak SAR (extrapolated) = 0.411 W/kg
SAR(1 g) = 0.230 mW/g; SAR(10 g) = 0.131 mW/g
Maximum value of SAR (measured) = 0.250 mW/g

Ch512/Zoom Scan (5x5x7)/Cube 1: Measurement grid: dx=8mm, dy=8mm, dz=5mm
Reference Value = 8.56 V/m; Power Drift = -0.109 dB
Peak SAR (extrapolated) = 0.283 W/kg
SAR(1 g) = 0.188 mW/g; SAR(10 g) = 0.122 mW/g
Maximum value of SAR (measured) = 0.202 mW/g

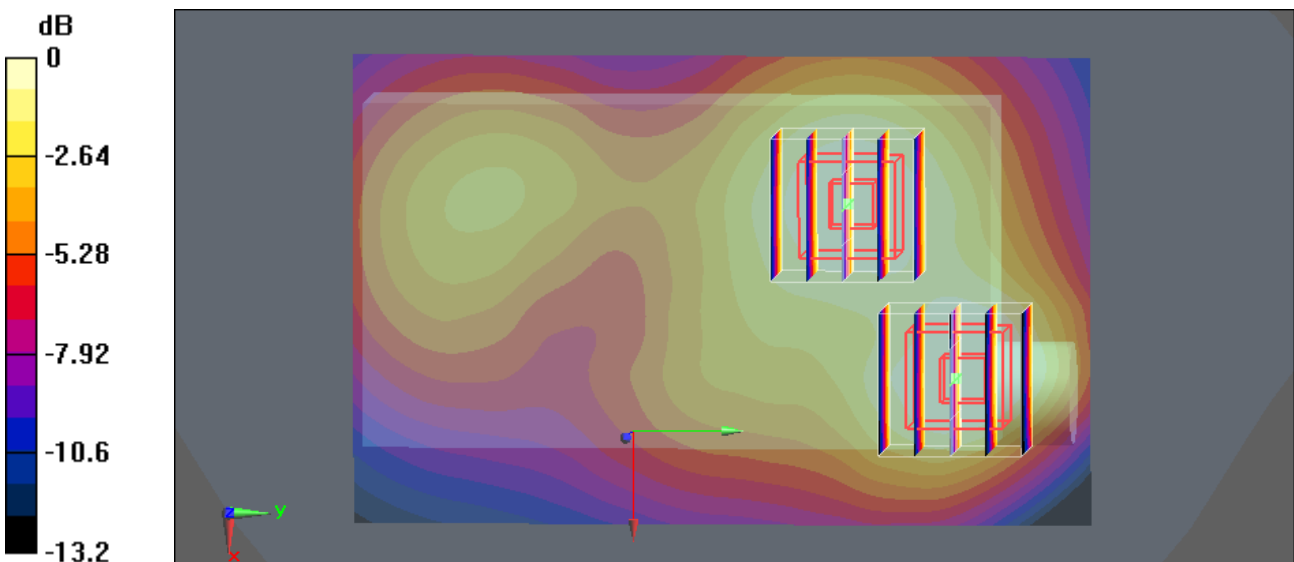

0 dB = 0.202mW/g

Test Laboratory: Sporton International Inc. SAR/HAC Testing Lab

Date: 2008/11/10

Body_GSM1900 Ch512_Face with Holster(1) 0cm Gap_GPRS10_2400mA_1D

DUT: 8o2811

Communication System: PCS; Frequency: 1850.2 MHz; Duty Cycle: 1:4
Medium: MSL_1900 Medium parameters used: $f = 1850.2$ MHz; $\sigma = 1.48$ mho/m; $\epsilon_r = 51.1$; $\rho = 1000$ kg/m³
Ambient Temperature : 22.4 ; Liquid Temperature : 21.6

DASY5 Configuration:

- Probe: ET3DV6 - SN1788; ConvF(4.73, 4.73, 4.73); Calibrated: 2008/9/23
- Sensor-Surface: 4mm (Mechanical Surface Detection)
- Electronics: DAE4 Sn778; Calibrated: 2008/9/22
- Phantom: SAM-Back; Type: QD 000 P40 C; Serial: TP-1383
- Measurement SW: DASY5, V5.0 Build 120; SEMCAD X Version 13.2 Build 87

Ch512/Area Scan (71x111x1): Measurement grid: dx=15mm, dy=15mm
Maximum value of SAR (interpolated) = 0.554 mW/g

Ch512/Zoom Scan (5x5x7)/Cube 0: Measurement grid: dx=8mm, dy=8mm, dz=5mm
Reference Value = 6.68 V/m; Power Drift = -0.076 dB
Peak SAR (extrapolated) = 0.614 W/kg
SAR(1 g) = 0.431 mW/g; SAR(10 g) = 0.250 mW/g
Maximum value of SAR (measured) = 0.479 mW/g

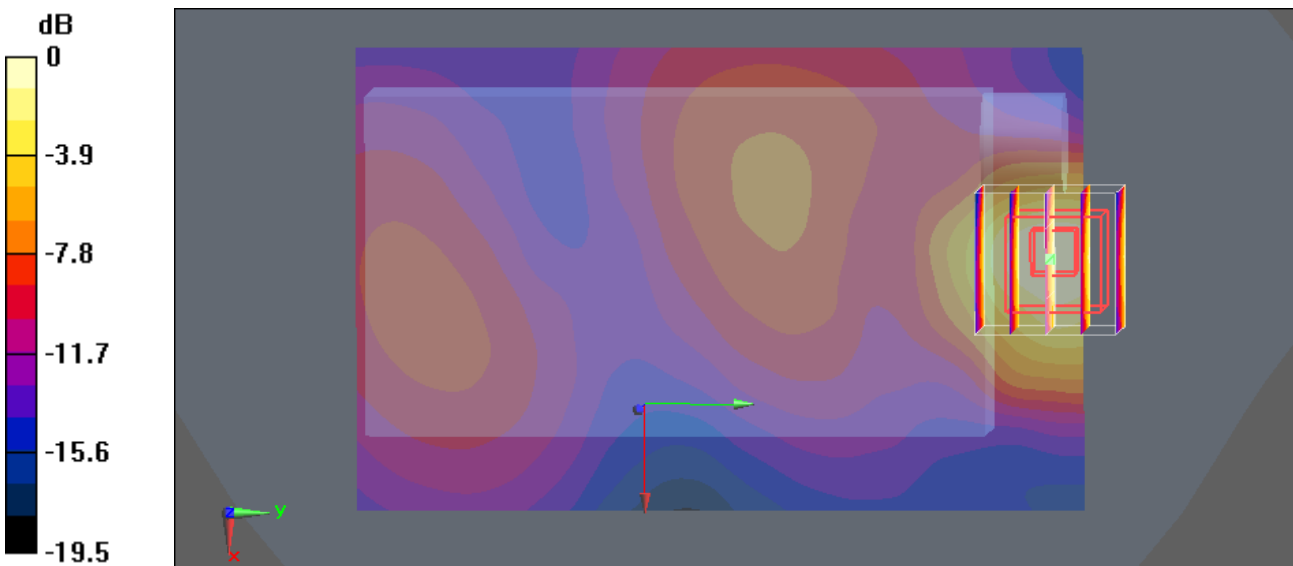

0 dB = 0.479mW/g

Test Laboratory: Sporton International Inc. SAR/HAC Testing Lab

Date: 2009/1/14

Body_GSM1900 Ch512_Bottom with Holster(1) 0cm Gap_GPRS10_3600mA_2D

DUT: 8o2811

Communication System: PCS; Frequency: 1850.2 MHz; Duty Cycle: 1:4
Medium: MSL_1900 Medium parameters used: $f = 1850.2$ MHz; $\sigma = 1.51$ mho/m; $\epsilon_r = 51.7$; $\rho = 1000$ kg/m³
Ambient Temperature : 22.4 ; Liquid Temperature : 21.4

DASY5 Configuration:

- Probe: ET3DV6 - SN1788; ConvF(4.73, 4.73, 4.73); Calibrated: 2008/9/23
- Sensor-Surface: 4mm (Mechanical Surface Detection)
- Electronics: DAE4 Sn778; Calibrated: 2008/9/22
- Phantom: SAM - Front; Type: SAM; Serial: TP-1446
- Measurement SW: DASY5, V5.0 Build 120; SEMCAD X Version 13.2 Build 87

CH512/Area Scan (71x121x1): Measurement grid: dx=15mm, dy=15mm
Maximum value of SAR (interpolated) = 0.586 mW/g

CH512/Zoom Scan (5x5x7)/Cube 0: Measurement grid: dx=8mm, dy=8mm, dz=5mm
Reference Value = 3.65 V/m; Power Drift = -0.192 dB
Peak SAR (extrapolated) = 0.694 W/kg
SAR(1 g) = 0.484 mW/g; SAR(10 g) = 0.295 mW/g
Maximum value of SAR (measured) = 0.524 mW/g

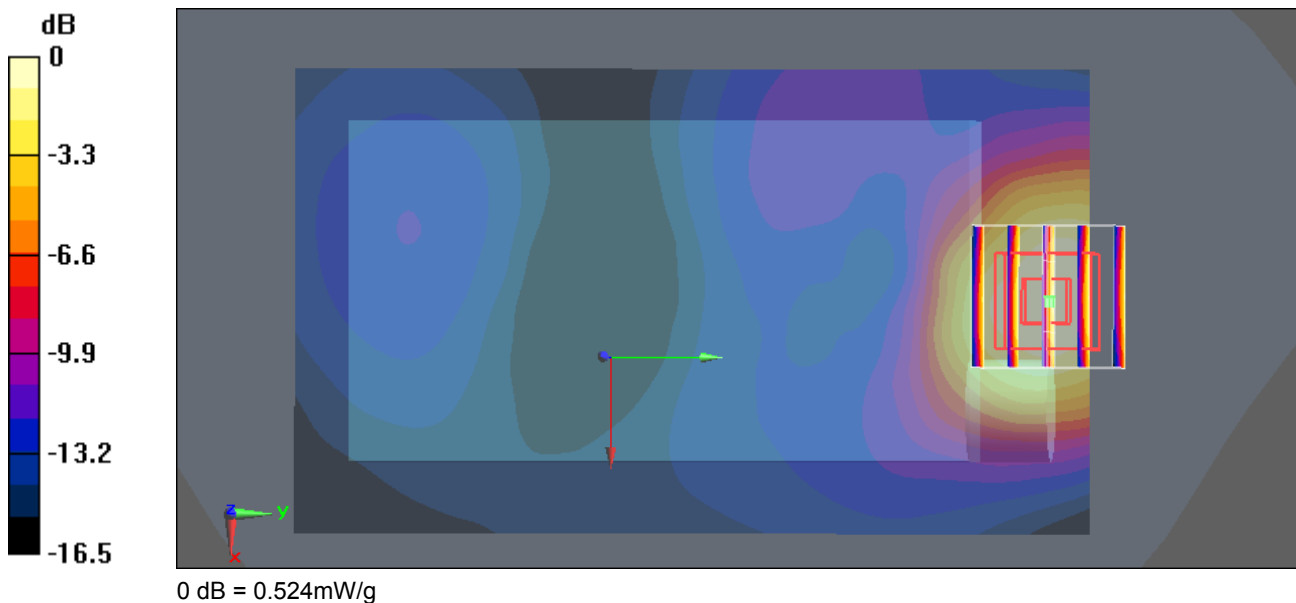

Test Laboratory: Sporton International Inc. SAR/HAC Testing Lab

Date: 2008/11/9

Body_GSM1900 Ch512_Face with Holster(2) 0cm Gap_GPRS10_2400mA_1D

DUT: 8o2811

Communication System: PCS; Frequency: 1850.2 MHz; Duty Cycle: 1:4
Medium: MSL_1900 Medium parameters used: $f = 1850.2$ MHz; $\sigma = 1.48$ mho/m; $\epsilon_r = 51.1$; $\rho = 1000$ kg/m³
Ambient Temperature : 22.5 ; Liquid Temperature : 21.6

DASY5 Configuration:

- Probe: ET3DV6 - SN1788; ConvF(4.73, 4.73, 4.73); Calibrated: 2008/9/23
- Sensor-Surface: 4mm (Mechanical Surface Detection)
- Electronics: DAE4 Sn778; Calibrated: 2008/9/22
- Phantom: SAM-Back; Type: QD 000 P40 C; Serial: TP-1383
- Measurement SW: DASY5, V5.0 Build 120; SEMCAD X Version 13.2 Build 87

Ch512/Area Scan (71x111x1): Measurement grid: dx=15mm, dy=15mm
Maximum value of SAR (interpolated) = 0.402 mW/g

Ch512/Zoom Scan (5x5x7)/Cube 0: Measurement grid: dx=8mm, dy=8mm, dz=5mm
Reference Value = 5.58 V/m; Power Drift = -0.053 dB
Peak SAR (extrapolated) = 0.572 W/kg

SAR(1 g) = 0.349 mW/g; SAR(10 g) = 0.189 mW/g
Maximum value of SAR (measured) = 0.389 mW/g

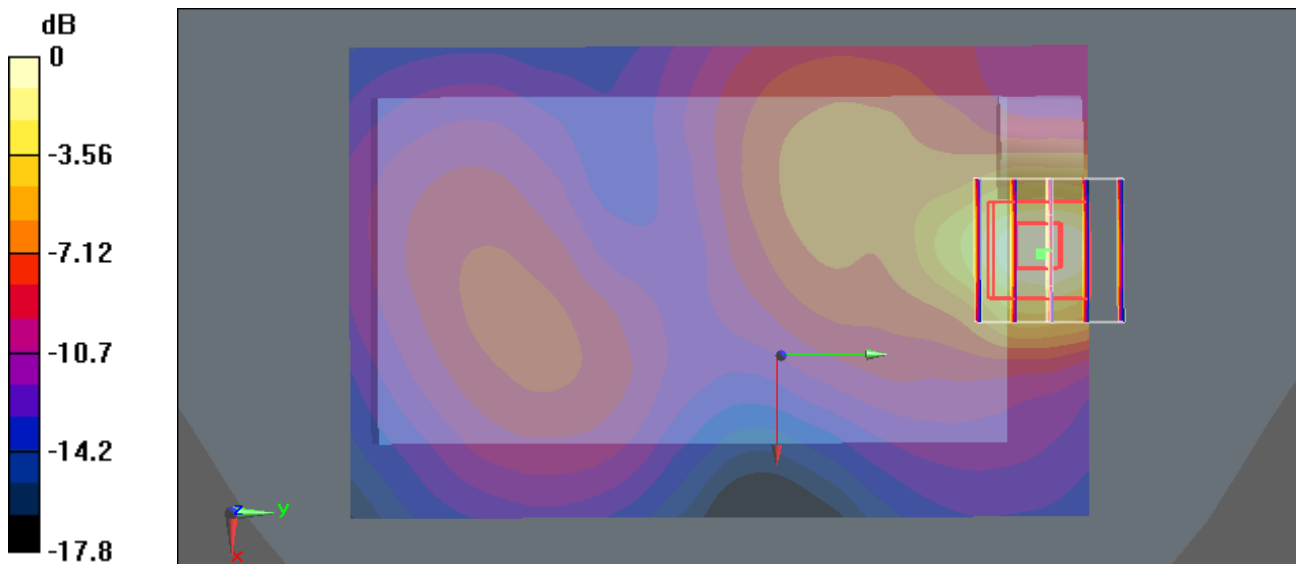

0 dB = 0.389mW/g

Test Laboratory: Sporton International Inc. SAR/HAC Testing Lab

Date: 2009/1/14

Body_GSM1900 Ch512_Face with Holster(3) 0cm Gap_GPRS10_3600mA_2D

DUT: 8o2811

Communication System: PCS; Frequency: 1850.2 MHz; Duty Cycle: 1:4
Medium: MSL_1900 Medium parameters used: $f = 1850.2$ MHz; $\sigma = 1.51$ mho/m; $\epsilon_r = 51.7$; $\rho = 1000$ kg/m³
Ambient Temperature : 22.4 ; Liquid Temperature : 21.4

DASY5 Configuration:

- Probe: ET3DV6 - SN1788; ConvF(4.73, 4.73, 4.73); Calibrated: 2008/9/23
- Sensor-Surface: 4mm (Mechanical Surface Detection)
- Electronics: DAE4 Sn778; Calibrated: 2008/9/22
- Phantom: SAM - Front; Type: SAM; Serial: TP-1446
- Measurement SW: DASY5, V5.0 Build 120; SEMCAD X Version 13.2 Build 87

Ch512/Area Scan (71x121x1): Measurement grid: dx=15mm, dy=15mm
Maximum value of SAR (interpolated) = 0.197 mW/g

Ch512/Zoom Scan (5x5x7)/Cube 0: Measurement grid: dx=8mm, dy=8mm, dz=5mm
Reference Value = 8.67 V/m; Power Drift = -0.099 dB
Peak SAR (extrapolated) = 0.279 W/kg
SAR(1 g) = 0.183 mW/g; SAR(10 g) = 0.119 mW/g
Maximum value of SAR (measured) = 0.193 mW/g

Ch512/Zoom Scan (5x5x7)/Cube 1: Measurement grid: dx=8mm, dy=8mm, dz=5mm
Reference Value = 8.67 V/m; Power Drift = -0.099 dB
Peak SAR (extrapolated) = 0.269 W/kg
SAR(1 g) = 0.170 mW/g; SAR(10 g) = 0.108 mW/g
Maximum value of SAR (measured) = 0.181 mW/g

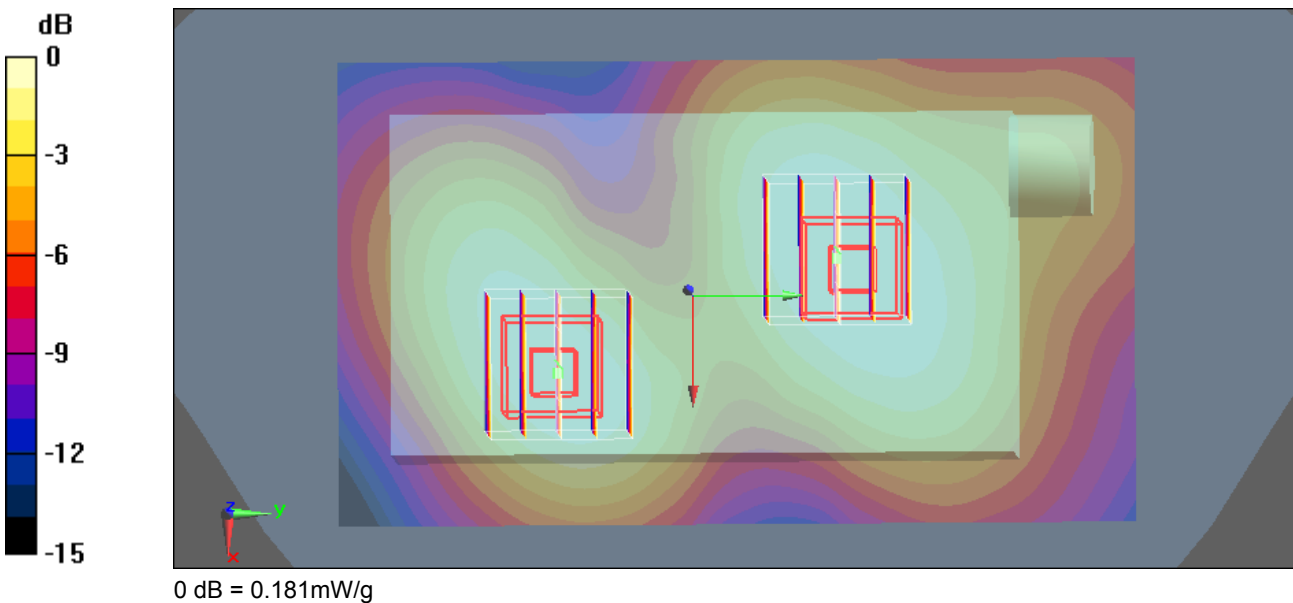

Test Laboratory: Sporton International Inc. SAR/HAC Testing Lab

Date: 2008/11/10

Body_GSM1900 Ch661_Bottom with Holster(3) 0cm Gap_GPRS12_2400mA_1D

DUT: 8o2811

Communication System: PCS; Frequency: 1880 MHz; Duty Cycle: 1:2
Medium: MSL_1900 Medium parameters used: $f = 1880 \text{ MHz}$; $\sigma = 1.51 \text{ mho/m}$; $\epsilon_r = 51.1$; $\rho = 1000 \text{ kg/m}^3$
Ambient Temperature : 22.4 ; Liquid Temperature : 21.6

DASY5 Configuration:

- Probe: ET3DV6 - SN1788; ConvF(4.73, 4.73, 4.73); Calibrated: 2008/9/23
- Sensor-Surface: 4mm (Mechanical Surface Detection)
- Electronics: DAE4 Sn778; Calibrated: 2008/9/22
- Phantom: SAM-Back; Type: QD 000 P40 C; Serial: TP-1383
- Measurement SW: DASY5, V5.0 Build 120; SEMCAD X Version 13.2 Build 87

Ch661/Area Scan (71x111x1): Measurement grid: dx=15mm, dy=15mm
Maximum value of SAR (interpolated) = 0.113 mW/g

Ch661/Zoom Scan (5x5x7)/Cube 0: Measurement grid: dx=8mm, dy=8mm, dz=5mm
Reference Value = 5.92 V/m; Power Drift = -0.164 dB
Peak SAR (extrapolated) = 0.158 W/kg
SAR(1 g) = 0.102 mW/g; SAR(10 g) = 0.065 mW/g
Maximum value of SAR (measured) = 0.110 mW/g

Ch661/Zoom Scan (5x5x7)/Cube 1: Measurement grid: dx=8mm, dy=8mm, dz=5mm
Reference Value = 5.92 V/m; Power Drift = -0.164 dB
Peak SAR (extrapolated) = 0.131 W/kg
SAR(1 g) = 0.085 mW/g; SAR(10 g) = 0.054 mW/g
Maximum value of SAR (measured) = 0.090 mW/g

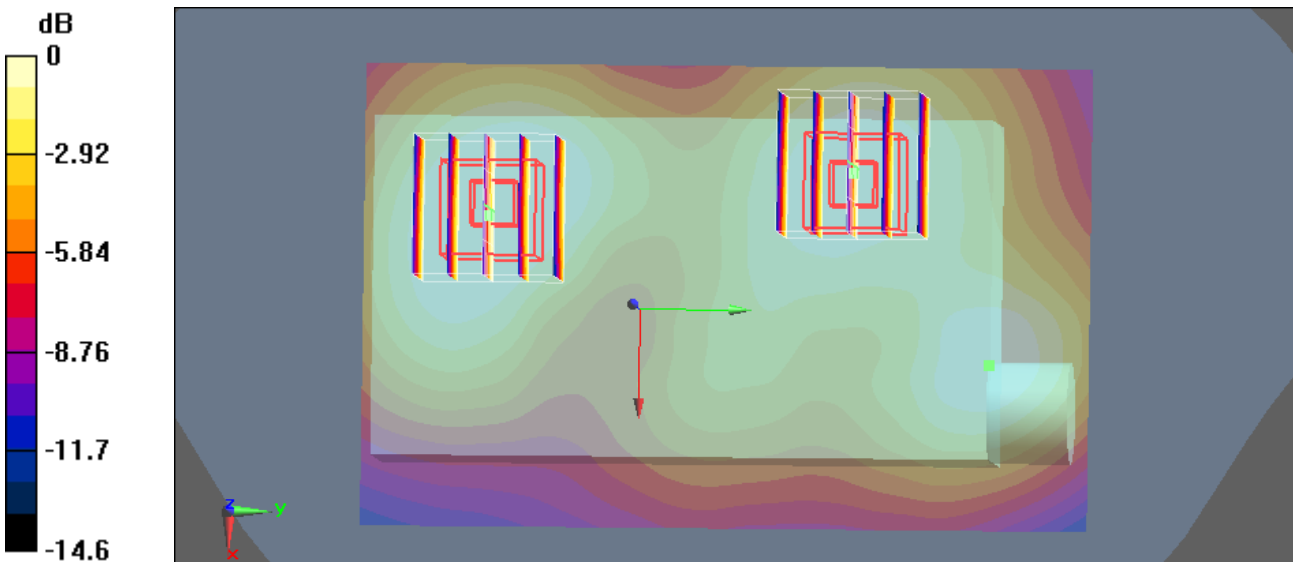

0 dB = 0.090mW/g



Test Laboratory: Sporton International Inc. SAR/HAC Testing Lab

Date: 2008/11/12

Right Cheek_GSM850 Ch251_2400mA_1D_Volume Scan

DUT: 8o2811

Communication System: GSM850; Frequency: 848.8 MHz; Duty Cycle: 1:8.3
Medium: HSL_850 Medium parameters used: $f = 849$ MHz; $\sigma = 0.914$ mho/m; $\epsilon_r = 43.2$; $\rho = 1000$ kg/m³
Ambient Temperature : 22.1 ; Liquid Temperature : 21.2

DASY5 Configuration:

- Probe: ET3DV6 - SN1788; ConvF(6.55, 6.55, 6.55); Calibrated: 2008/9/23
- Sensor-Surface: 4mm (Mechanical Surface Detection)
- Electronics: DAE4 Sn778; Calibrated: 2008/9/22
- Phantom: SAM - Front; Type: SAM; Serial: TP-1446
- Measurement SW: DASY5, V5.0 Build 120; SEMCAD X Version 13.2 Build 87

Ch251/Volume Scan (14x25x10): Measurement grid: dx=8mm, dy=8mm, dz=5mm

Reference Value = 33.3 V/m; Power Drift = -0.156 dB

Peak SAR (extrapolated) = 2.44 W/kg

SAR(1 g) = 1.41 mW/g; SAR(10 g) = 0.904 mW/g

Total Absorbed Power = 0.128846 W

Maximum value of SAR (measured) = 1.53 mW/g

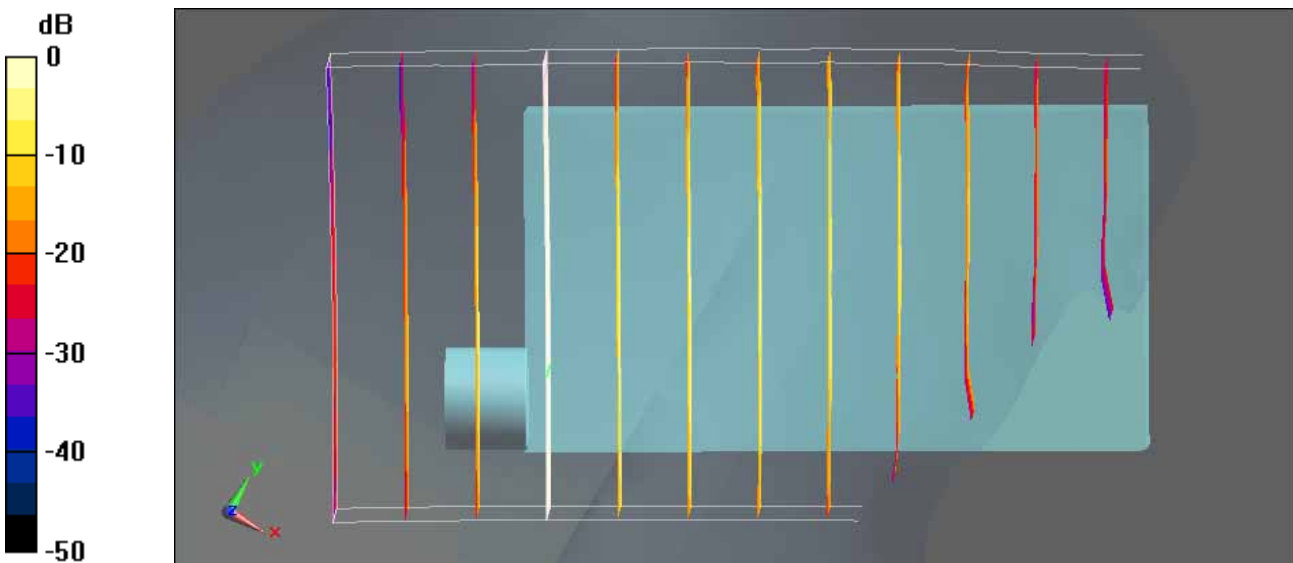

0 dB = 1.53mW/g

Test Laboratory: Sporton International Inc. SAR/HAC Testing Lab

Date: 2008/11/11

Right Cheek_802.11g Ch6_2400mA_1D_Volume Scan

DUT: 8o2811

Communication System: 802.11g; Frequency: 2437 MHz; Duty Cycle: 1:1
Medium: HSL_2450 Medium parameters used: $f = 2437$ MHz; $\sigma = 1.83$ mho/m; $\epsilon_r = 37.7$; $\rho = 1000$ kg/m³
Ambient Temperature : 22.5 ; Liquid Temperature : 21.6

DASY5 Configuration:

- Probe: ET3DV6 - SN1788; ConvF(4.68, 4.68, 4.68); Calibrated: 2008/9/23
- Sensor-Surface: 4mm (Mechanical Surface Detection)
- Electronics: DAE4 Sn778; Calibrated: 2008/9/22
- Phantom: SAM-Back; Type: QD 000 P40 C; Serial: TP-1383
- Measurement SW: DASY5, V5.0 Build 120; SEMCAD X Version 13.2 Build 87

Ch6/Volume Scan (14x25x10): Measurement grid: dx=8mm, dy=8mm, dz=5mm
Reference Value = 4.73 V/m; Power Drift = -0.154 dB
Peak SAR (extrapolated) = 0.079 W/kg
SAR(1 g) = 0.041 mW/g; SAR(10 g) = 0.021 mW/g
Total Absorbed Power = 0.00106975 W
Maximum value of SAR (measured) = 0.043 mW/g

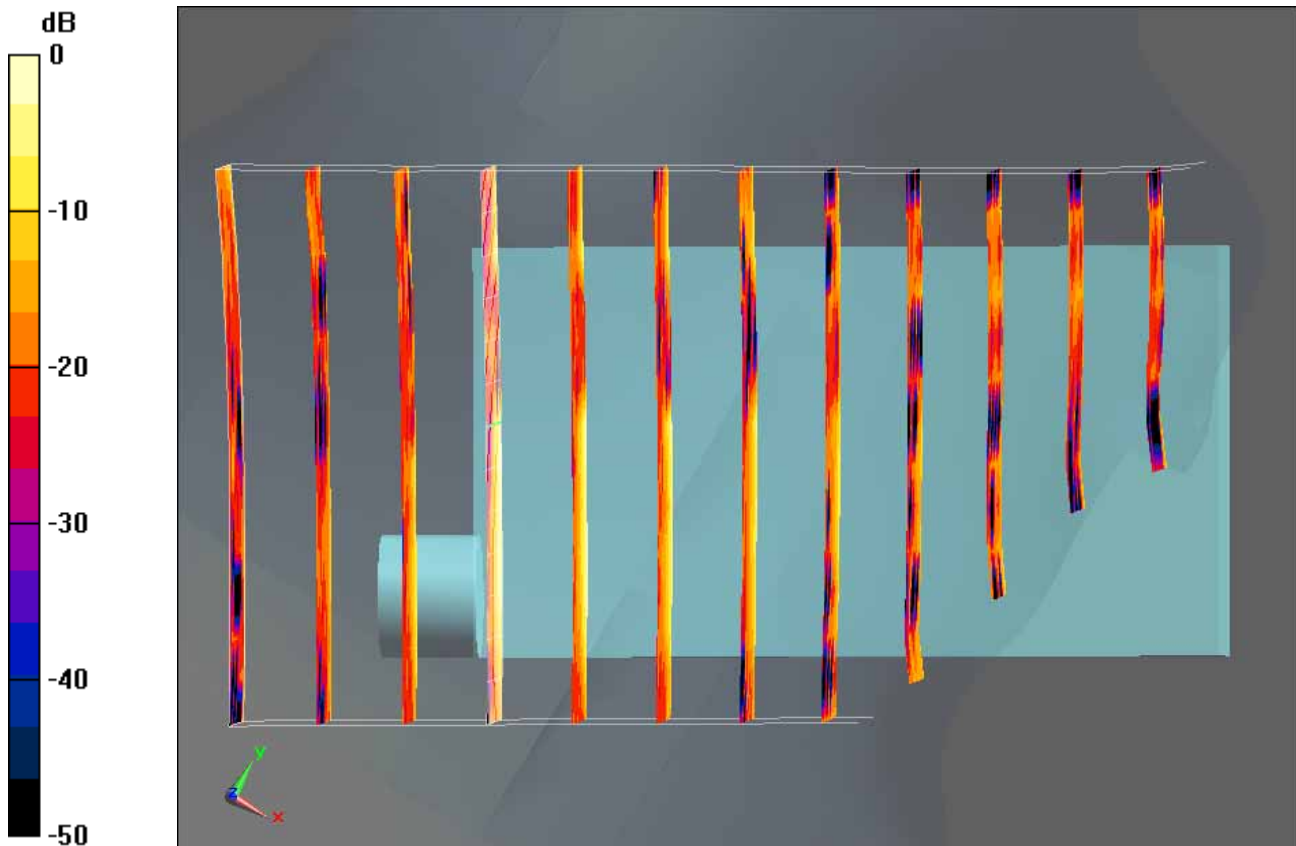

0 dB = 0.043mW/g



Test Laboratory: Sporton International Inc. SAR/HAC Testing Lab

Date: 2008/11/12

Right Cheek_GSM850 Ch251_2400mA_1D_#0303_Volume Scan

DUT: 8o2811

Communication System: GSM850; Frequency: 848.8 MHz; Duty Cycle: 1:8.3

Medium: HSL_850 Medium parameters used: $f = 849$ MHz; $\sigma = 0.914$ mho/m; $\epsilon_r = 43.2$; $\rho = 1000$ kg/m³

Phantom section: Right Section

Measurement Standard: DASy5 (IEEE/IEC)

Test Laboratory: Sporton International Inc. SAR/HAC Testing Lab

Date: 2008/11/11

Right Cheek_802.11g Ch6_2400mA_1D_#0303_Volume Scan

DUT: 8o2811

Communication System: 802.11g; Frequency: 2437 MHz; Duty Cycle: 1:1

Medium: HSL_2450 Medium parameters used: $f = 2437$ MHz; $\sigma = 1.83$ mho/m; $\epsilon_r = 37.7$; $\rho = 1000$ kg/m³

Phantom section: Right Section

Measurement Standard: DASy5 (IEEE/IEC)

Multi Band Result:

SAR(1 g) = 1.45 mW/g; SAR(10 g) = 0.924 mW/g

Maximum value of SAR (measured) = 1.57 mW/g

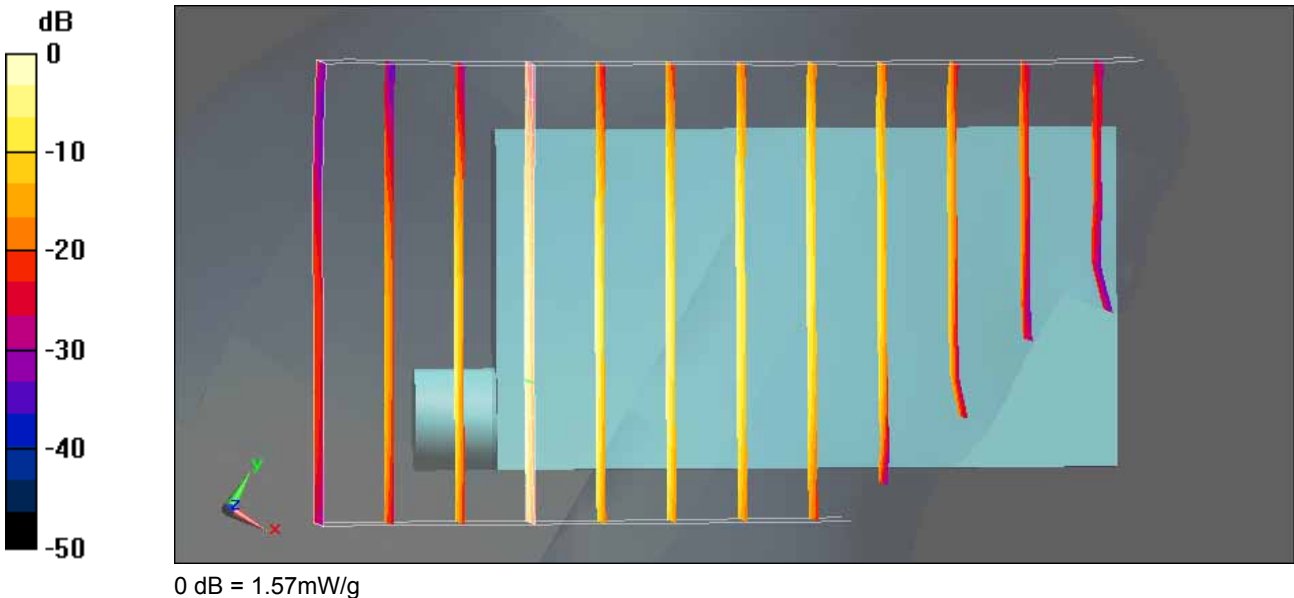



Test Laboratory: Sporton International Inc. SAR/HAC Testing Lab

Date: 2008/11/9

Right Cheek_GSM850 Ch251_2400mA_1D (2D Plot)

DUT: 8o2811

Communication System: GSM850; Frequency: 848.8 MHz;Duty Cycle: 1:8.3
Medium: HSL_850 Medium parameters used: f = 849 MHz; $\sigma = 0.916$ mho/m; $\epsilon_r = 43.3$; $\rho = 1000$ kg/m³
Ambient Temperature : 22.5 ; Liquid Temperature : 21.4

DASY5 Configuration:

- Probe: ET3DV6 - SN1788; ConvF(6.55, 6.55, 6.55); Calibrated: 2008/9/23
- Sensor-Surface: 4mm (Mechanical Surface Detection)
- Electronics: DAE4 Sn778; Calibrated: 2008/9/22
- Phantom: SAM - Front; Type: SAM; Serial: TP-1446
- Measurement SW: DASY5, V5.0 Build 120; SEMCAD X Version 13.2 Build 87

Ch251/Area Scan (71x111x1): Measurement grid: dx=15mm, dy=15mm
Maximum value of SAR (interpolated) = 1.51 mW/g

Ch251/Zoom Scan (5x5x7)/Cube 0: Measurement grid: dx=8mm, dy=8mm, dz=5mm
Reference Value = 33.4 V/m; Power Drift = 0.039 dB
Peak SAR (extrapolated) = 2.3 W/kg
SAR(1 g) = 1.33 mW/g; SAR(10 g) = 0.852 mW/g
Maximum value of SAR (measured) = 1.45 mW/g

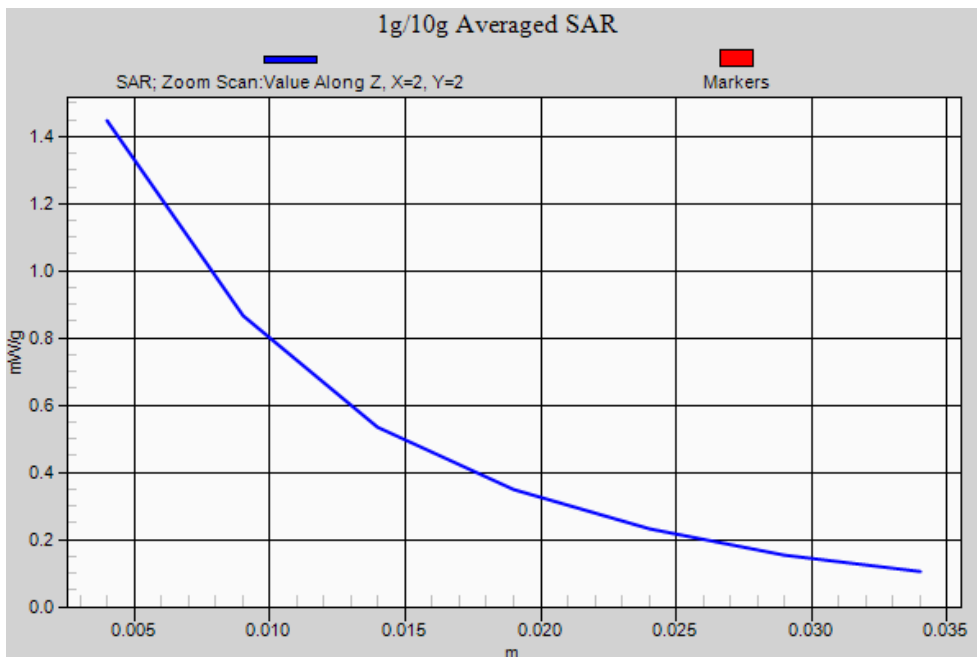



Test Laboratory: Sporton International Inc. SAR/HAC Testing Lab

Date: 2008/11/12

Body_GSM850 Ch251_Face with 1.5cm Gap_GPRS10_2400mA_1D (2D Plot)

DUT: 8o2811

Communication System: GSM850; Frequency: 848.8 MHz; Duty Cycle: 1:4
Medium: MSL_850 Medium parameters used: $f = 849$ MHz; $\sigma = 0.971$ mho/m; $\epsilon_r = 52.8$; $\rho = 1000$ kg/m³
Ambient Temperature : 22.4 ; Liquid Temperature : 21.2

DASY5 Configuration:

- Probe: ET3DV6 - SN1788; ConvF(6.34, 6.34, 6.34); Calibrated: 2008/9/23
- Sensor-Surface: 4mm (Mechanical Surface Detection)
- Electronics: DAE4 Sn778; Calibrated: 2008/9/22
- Phantom: SAM-Back; Type: QD 000 P40 C; Serial: TP-1383
- Measurement SW: DASY5, V5.0 Build 120; SEMCAD X Version 13.2 Build 87

Ch251/Area Scan (71x111x1): Measurement grid: dx=15mm, dy=15mm
Maximum value of SAR (interpolated) = 0.409 mW/g

Ch251/Zoom Scan (5x5x7)/Cube 0: Measurement grid: dx=8mm, dy=8mm, dz=5mm
Reference Value = 21.2 V/m; Power Drift = -0.036 dB
Peak SAR (extrapolated) = 0.458 W/kg
SAR(1 g) = 0.387 mW/g; SAR(10 g) = 0.297 mW/g
Maximum value of SAR (measured) = 0.406 mW/g

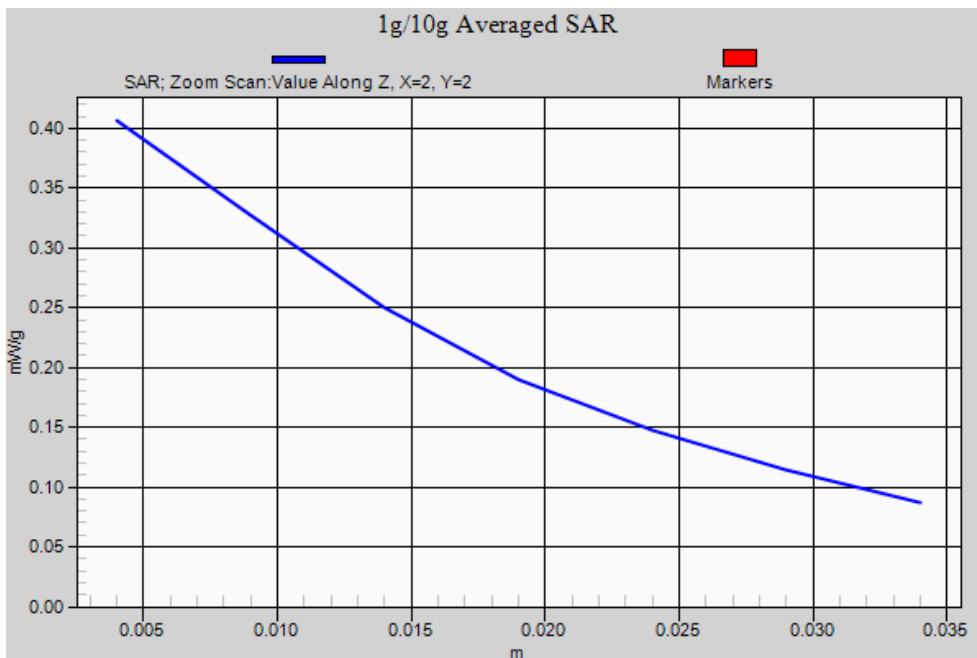



Test Laboratory: Sporton International Inc. SAR/HAC Testing Lab

Date: 2008/11/10

Body_GSM850 Ch251_Face with Holster(1) 0cm Gap_GPRS10_2400mA_1D (2D Plot)

DUT: 8o2811

Communication System: GSM850; Frequency: 848.8 MHz; Duty Cycle: 1:4
Medium: MSL_850 Medium parameters used: $f = 849$ MHz; $\sigma = 0.967$ mho/m; $\epsilon_r = 52.5$; $\rho = 1000$ kg/m³
Ambient Temperature : 22.5 ; Liquid Temperature : 21.3

DASY5 Configuration:

- Probe: ET3DV6 - SN1788; ConvF(6.34, 6.34, 6.34); Calibrated: 2008/9/23
- Sensor-Surface: 4mm (Mechanical Surface Detection)
- Electronics: DAE4 Sn778; Calibrated: 2008/9/22
- Phantom: SAM - Front; Type: SAM; Serial: TP-1446
- Measurement SW: DASY5, V5.0 Build 120; SEMCAD X Version 13.2 Build 87

Ch251/Area Scan (71x111x1): Measurement grid: dx=15mm, dy=15mm
Maximum value of SAR (interpolated) = 0.122 mW/g

Ch251/Zoom Scan (5x5x7)/Cube 0: Measurement grid: dx=8mm, dy=8mm, dz=5mm
Reference Value = 11.6 V/m; Power Drift = -0.017 dB
Peak SAR (extrapolated) = 0.137 W/kg

SAR(1 g) = 0.116 mW/g; SAR(10 g) = 0.089 mW/g
Maximum value of SAR (measured) = 0.121 mW/g

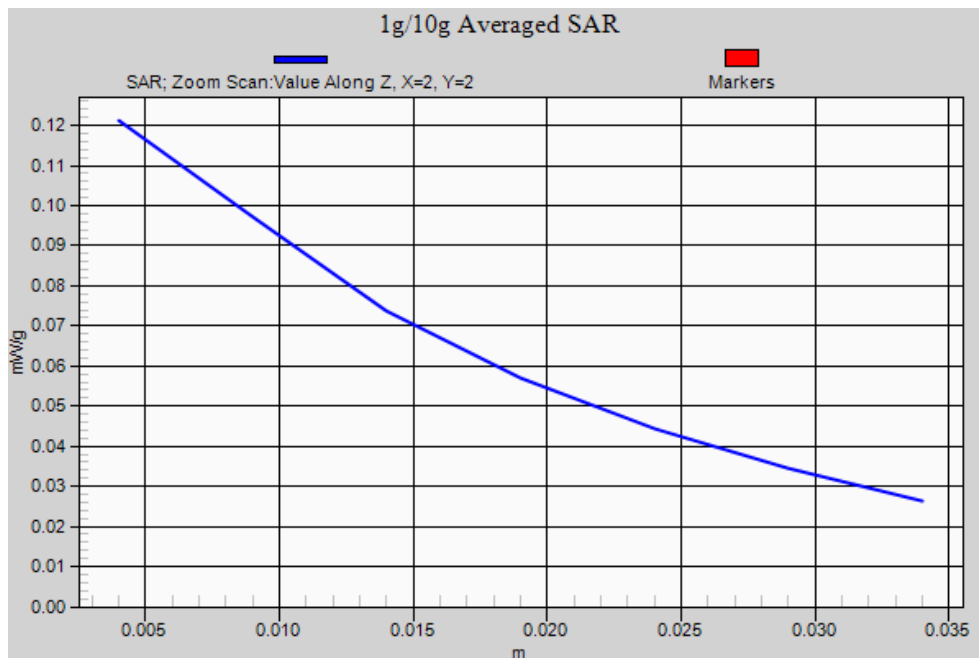



Test Laboratory: Sporton International Inc. SAR/HAC Testing Lab

Date: 2008/11/9

Body_GSM850 Ch251_Face with Holster(2) 0cm Gap_GPRS10_2400mA_1D (2D Plot)

DUT: 8o2811

Communication System: GSM850; Frequency: 848.8 MHz; Duty Cycle: 1:4
Medium: MSL_850 Medium parameters used: f = 849 MHz; sigma = 0.967 mho/m; epsilon_r = 52.5; rho = 1000 kg/m^3
Ambient Temperature : 22.4 ; Liquid Temperature : 21.3

DASY5 Configuration:

- Probe: ET3DV6 - SN1788; ConvF(6.34, 6.34, 6.34); Calibrated: 2008/9/23
- Sensor-Surface: 4mm (Mechanical Surface Detection)
- Electronics: DAE4 Sn778; Calibrated: 2008/9/22
- Phantom: SAM - Front; Type: SAM; Serial: TP-1446
- Measurement SW: DASY5, V5.0 Build 120; SEMCAD X Version 13.2 Build 87

Ch251/Area Scan (71x111x1): Measurement grid: dx=15mm, dy=15mm
Maximum value of SAR (interpolated) = 0.209 mW/g

Ch251/Zoom Scan (5x5x7)/Cube 0: Measurement grid: dx=8mm, dy=8mm, dz=5mm
Reference Value = 15.2 V/m; Power Drift = -0.012 dB
Peak SAR (extrapolated) = 0.235 W/kg
SAR(1 g) = 0.197 mW/g; SAR(10 g) = 0.151 mW/g
Maximum value of SAR (measured) = 0.208 mW/g

Ch251/Zoom Scan (5x5x7)/Cube 1: Measurement grid: dx=8mm, dy=8mm, dz=5mm
Reference Value = 15.2 V/m; Power Drift = -0.012 dB
Peak SAR (extrapolated) = 0.205 W/kg
SAR(1 g) = 0.161 mW/g; SAR(10 g) = 0.117 mW/g
Maximum value of SAR (measured) = 0.175 mW/g

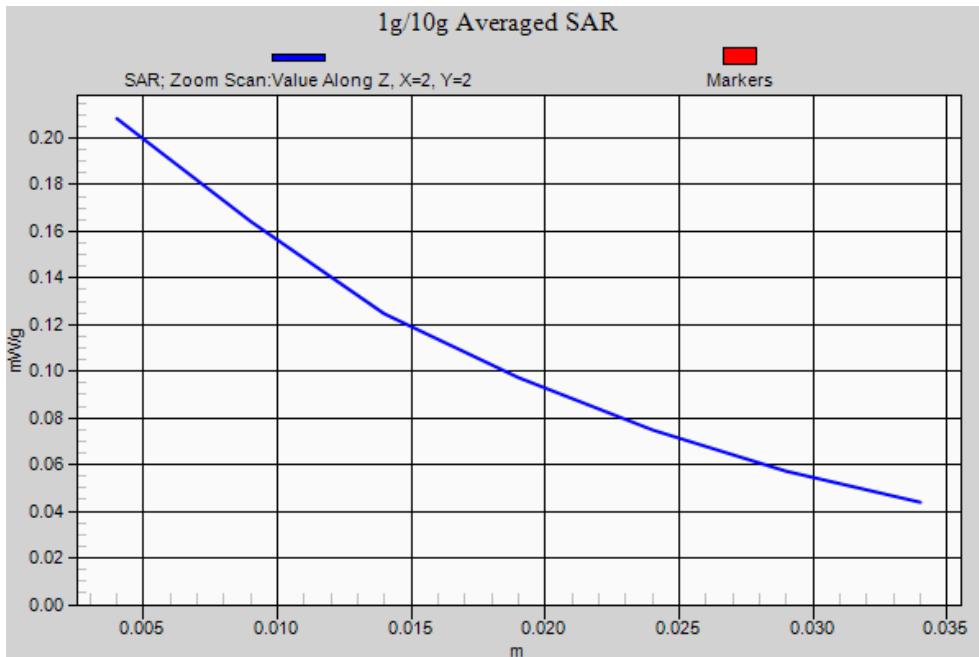



Test Laboratory: Sporton International Inc. SAR/HAC Testing Lab

Date: 2008/11/10

Body_GSM850 Ch251_Face with Holster(3) 0cm Gap_GPRS10_2400mA_1D (2D Plot)

DUT: 8o2811

Communication System: GSM850; Frequency: 848.8 MHz; Duty Cycle: 1:4
Medium: MSL_850 Medium parameters used: $f = 849$ MHz; $\sigma = 0.967$ mho/m; $\epsilon_r = 52.5$; $\rho = 1000$ kg/m³
Ambient Temperature : 22.5 ; Liquid Temperature : 21.3

DASY5 Configuration:

- Probe: ET3DV6 - SN1788; ConvF(6.34, 6.34, 6.34); Calibrated: 2008/9/23
- Sensor-Surface: 4mm (Mechanical Surface Detection)
- Electronics: DAE4 Sn778; Calibrated: 2008/9/22
- Phantom: SAM - Front; Type: SAM; Serial: TP-1446
- Measurement SW: DASY5, V5.0 Build 120; SEMCAD X Version 13.2 Build 87

Ch251/Area Scan (71x111x1): Measurement grid: dx=15mm, dy=15mm
Maximum value of SAR (interpolated) = 0.372 mW/g

Ch251/Zoom Scan (5x5x7)/Cube 0: Measurement grid: dx=8mm, dy=8mm, dz=5mm
Reference Value = 19.9 V/m; Power Drift = -0.059 dB
Peak SAR (extrapolated) = 0.419 W/kg
SAR(1 g) = 0.351 mW/g; SAR(10 g) = 0.267 mW/g
Maximum value of SAR (measured) = 0.370 mW/g

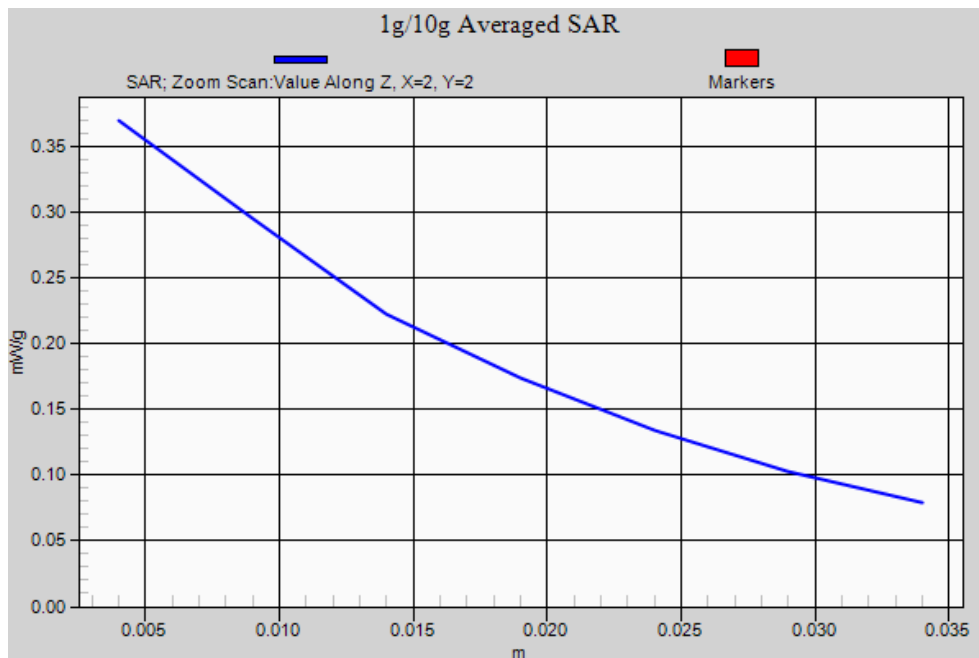



Test Laboratory: Sporton International Inc. SAR/HAC Testing Lab

Date: 2009/1/14

Right Cheek_GSM1900 Ch810_3600mA_2D_#0110_2D

DUT: 8o2811

Communication System: PCS; Frequency: 1909.8 MHz; Duty Cycle: 1:8.3
Medium: HSL_1900 Medium parameters used: $f = 1910$ MHz; $\sigma = 1.47$ mho/m; $\epsilon_r = 38$; $\rho = 1000$ kg/m³
Ambient Temperature : 22.5 ; Liquid Temperature : 21.5

DASY5 Configuration:

- Probe: ET3DV6 - SN1788; ConvF(5.13, 5.13, 5.13); Calibrated: 2008/9/23
- Sensor-Surface: 4mm (Mechanical Surface Detection)
- Electronics: DAE4 Sn778; Calibrated: 2008/9/22
- Phantom: SAM - Front; Type: SAM; Serial: TP-1446
- Measurement SW: DASY5, V5.0 Build 120; SEMCAD X Version 13.2 Build 87

Ch810/Area Scan (71x121x1): Measurement grid: dx=15mm, dy=15mm
Maximum value of SAR (interpolated) = 0.632 mW/g

Ch810/Zoom Scan (5x5x7)/Cube 0: Measurement grid: dx=8mm, dy=8mm, dz=5mm
Reference Value = 14.7 V/m; Power Drift = -0.028 dB
Peak SAR (extrapolated) = 1.000 W/kg
SAR(1 g) = 0.567 mW/g; SAR(10 g) = 0.329 mW/g
Maximum value of SAR (measured) = 0.592 mW/g

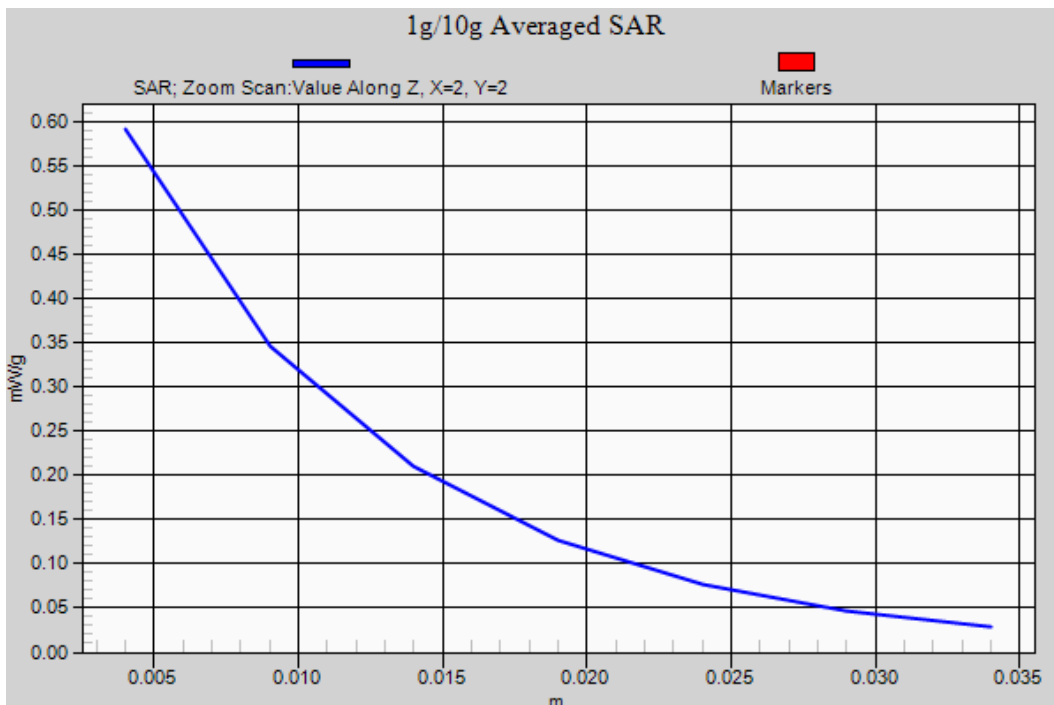



Test Laboratory: Sporton International Inc. SAR/HAC Testing Lab

Date: 2008/11/12

Body_GSM1900 Ch512_Bottom with 1.5cm Gap_GPRS10_2400mA_1D (2D Plot)

DUT: 8o2811

Communication System: PCS; Frequency: 1850.2 MHz; Duty Cycle: 1:4
Medium: MSL_1900 Medium parameters used : f = 1850.2 MHz; sigma = 1.48 mho/m; epsilon_r = 51.1; rho = 1000 kg/m^3
Ambient Temperature : 22.5 ; Liquid Temperature : 21.4

DASY5 Configuration:

- Probe: ET3DV6 - SN1788; ConvF(4.73, 4.73, 4.73); Calibrated: 2008/9/23
- Sensor-Surface: 4mm (Mechanical Surface Detection)
- Electronics: DAE4 Sn778; Calibrated: 2008/9/22
- Phantom: SAM-Back; Type: QD 000 P40 C; Serial: TP-1383
- Measurement SW: DASY5, V5.0 Build 120; SEMCAD X Version 13.2 Build 87

Ch512/Area Scan (71x111x1): Measurement grid: dx=15mm, dy=15mm
Maximum value of SAR (interpolated) = 0.258 mW/g

Ch512/Zoom Scan (5x5x7)/Cube 0: Measurement grid: dx=8mm, dy=8mm, dz=5mm
Reference Value = 8.56 V/m; Power Drift = -0.109 dB
Peak SAR (extrapolated) = 0.411 W/kg
SAR(1 g) = 0.230 mW/g; SAR(10 g) = 0.131 mW/g
Maximum value of SAR (measured) = 0.250 mW/g

Ch512/Zoom Scan (5x5x7)/Cube 1: Measurement grid: dx=8mm, dy=8mm, dz=5mm
Reference Value = 8.56 V/m; Power Drift = -0.109 dB
Peak SAR (extrapolated) = 0.283 W/kg
SAR(1 g) = 0.188 mW/g; SAR(10 g) = 0.122 mW/g
Maximum value of SAR (measured) = 0.202 mW/g

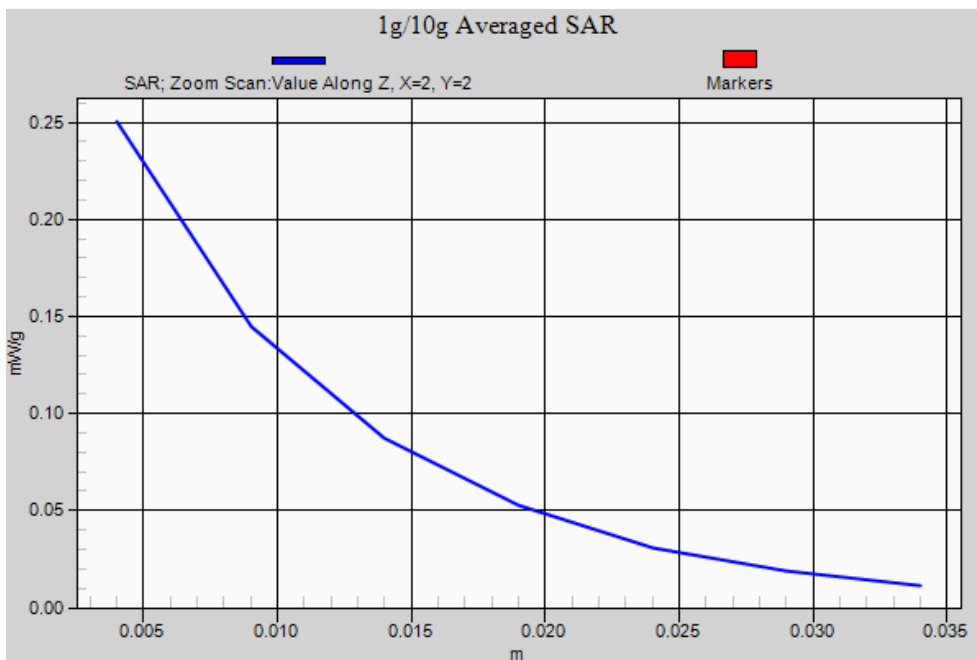



Test Laboratory: Sporton International Inc. SAR/HAC Testing Lab

Date: 2009/1/15

Body_GSM1900 Ch512_Bottom with Holster(1) 0cm Gap_GPRS10_3600mA_2D (2D Plot)

DUT: 8o2811

Communication System: PCS; Frequency: 1850.2 MHz; Duty Cycle: 1:4
Medium: MSL_1900 Medium parameters used: $f = 1850.2$ MHz; $\sigma = 1.51$ mho/m; $\epsilon_r = 51.7$; $\rho = 1000$ kg/m³
Ambient Temperature : 22.4 ; Liquid Temperature : 21.4

DASY5 Configuration:

- Probe: ET3DV6 - SN1788; ConvF(4.73, 4.73, 4.73); Calibrated: 2008/9/23
- Sensor-Surface: 4mm (Mechanical Surface Detection)
- Electronics: DAE4 Sn778; Calibrated: 2008/9/22
- Phantom: SAM - Front; Type: SAM; Serial: TP-1446
- Measurement SW: DASY5, V5.0 Build 120; SEMCAD X Version 13.2 Build 87

CH512/Area Scan (71x121x1): Measurement grid: dx=15mm, dy=15mm
Maximum value of SAR (interpolated) = 0.586 mW/g

CH512/Zoom Scan (5x5x7)/Cube 0: Measurement grid: dx=8mm, dy=8mm, dz=5mm
Reference Value = 3.65 V/m; Power Drift = -0.192 dB
Peak SAR (extrapolated) = 0.694 W/kg
SAR(1 g) = 0.484 mW/g; SAR(10 g) = 0.295 mW/g
Maximum value of SAR (measured) = 0.524 mW/g

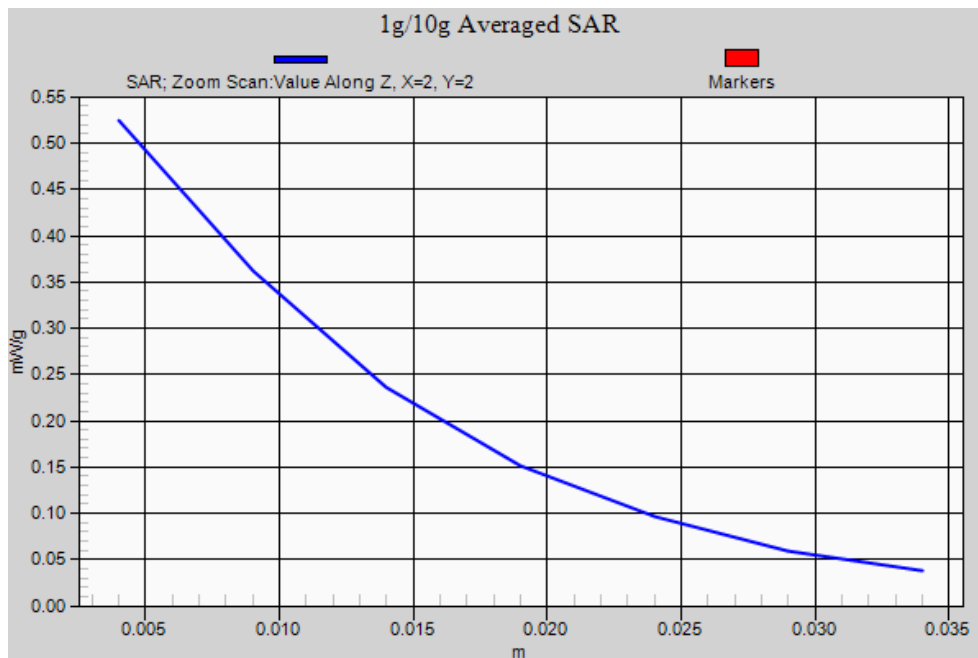



Test Laboratory: Sporton International Inc. SAR/HAC Testing Lab

Date: 2008/11/9

Body_GSM1900 Ch512_Face with Holster(2) 0cm Gap_GPRS10_2400mA_1D (2D Plot)

DUT: 8o2811

Communication System: PCS; Frequency: 1850.2 MHz; Duty Cycle: 1:4
Medium: MSL_1900 Medium parameters used: $f = 1850.2$ MHz; $\sigma = 1.48$ mho/m; $\epsilon_r = 51.1$; $\rho = 1000$ kg/m³
Ambient Temperature : 22.4 ; Liquid Temperature : 21.6

DASY5 Configuration:

- Probe: ET3DV6 - SN1788; ConvF(4.73, 4.73, 4.73); Calibrated: 2008/9/23
- Sensor-Surface: 4mm (Mechanical Surface Detection)
- Electronics: DAE4 Sn778; Calibrated: 2008/9/22
- Phantom: SAM-Back; Type: QD 000 P40 C; Serial: TP-1383
- Measurement SW: DASY5, V5.0 Build 120; SEMCAD X Version 13.2 Build 87

Ch512/Area Scan (71x111x1): Measurement grid: dx=15mm, dy=15mm
Maximum value of SAR (interpolated) = 0.402 mW/g

Ch512/Zoom Scan (5x5x7)/Cube 0: Measurement grid: dx=8mm, dy=8mm, dz=5mm
Reference Value = 5.58 V/m; Power Drift = -0.053 dB
Peak SAR (extrapolated) = 0.572 W/kg
SAR(1 g) = 0.349 mW/g; SAR(10 g) = 0.189 mW/g
Maximum value of SAR (measured) = 0.389 mW/g

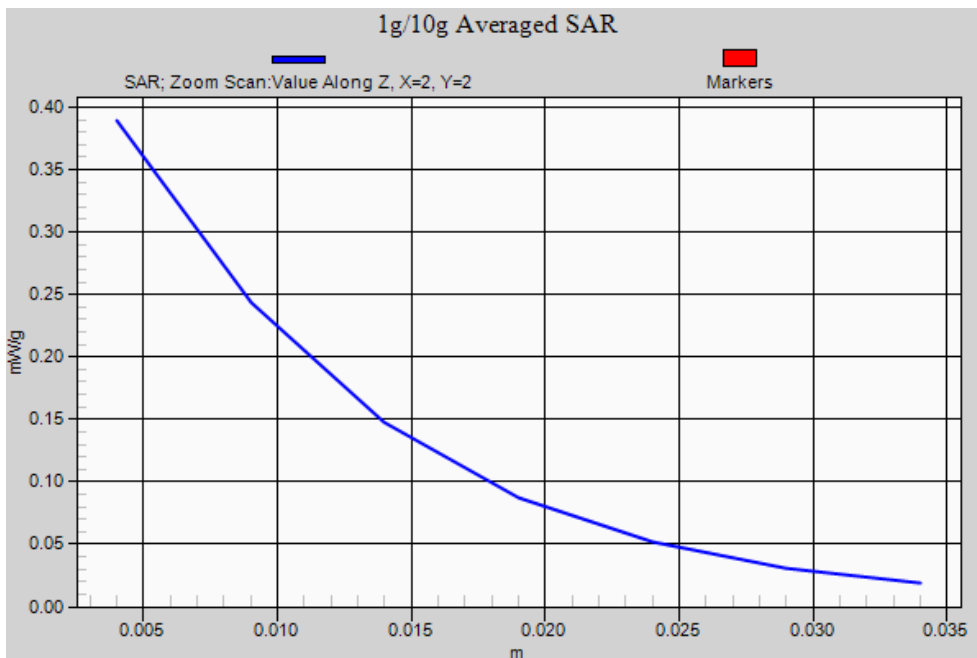



Test Laboratory: Sporton International Inc. SAR/HAC Testing Lab

Date: 2009/1/14

Body_GSM1900 Ch512_Face with Holster(3) 0cm Gap_GPRS10_3600mA_2D (2D Plot)

DUT: 8o2811

Communication System: PCS; Frequency: 1850.2 MHz; Duty Cycle: 1:4
Medium: MSL_1900 Medium parameters used: f = 1850.2 MHz; sigma = 1.51 mho/m; epsilon_r = 51.7; rho = 1000 kg/m^3
Ambient Temperature : 22.4 ; Liquid Temperature : 21.4

DASY5 Configuration:

- Probe: ET3DV6 - SN1788; ConvF(4.73, 4.73, 4.73); Calibrated: 2008/9/23
- Sensor-Surface: 4mm (Mechanical Surface Detection)
- Electronics: DAE4 Sn778; Calibrated: 2008/9/22
- Phantom: SAM - Front; Type: SAM; Serial: TP-1446
- Measurement SW: DASY5, V5.0 Build 120; SEMCAD X Version 13.2 Build 87

Ch512/Area Scan (71x121x1): Measurement grid: dx=15mm, dy=15mm
Maximum value of SAR (interpolated) = 0.197 mW/g

Ch512/Zoom Scan (5x5x7)/Cube 0: Measurement grid: dx=8mm, dy=8mm, dz=5mm
Reference Value = 8.67 V/m; Power Drift = -0.099 dB
Peak SAR (extrapolated) = 0.279 W/kg
SAR(1 g) = 0.183 mW/g; SAR(10 g) = 0.119 mW/g
Maximum value of SAR (measured) = 0.193 mW/g

Ch512/Zoom Scan (5x5x7)/Cube 1: Measurement grid: dx=8mm, dy=8mm, dz=5mm
Reference Value = 8.67 V/m; Power Drift = -0.099 dB
Peak SAR (extrapolated) = 0.269 W/kg
SAR(1 g) = 0.170 mW/g; SAR(10 g) = 0.108 mW/g
Maximum value of SAR (measured) = 0.181 mW/g

