



# FCC Test Report

According to

## 47 CFR Part 15 Subpart B

**Equipment** : EDA (Enterprise Digital Assistant)

**Trade Name** : Symbol

**Model No.** : MC5574

**FCC ID** : H9PMC5574

**Applicant** : Symbol Technologies Inc

One Symbol Plaza Holtsville, NY 11742 -1300 United States

- The test result refers exclusively to the test presented test model / sample.
- Without written approval of SPORTON International Inc., the test report shall not be reproduced except in full.
- Certificate or Test Report must not be used by the applicant to claim the product in this test report endorsement by NVLAP or any agency of U.S. government.
- Report Version: Rev. 01

***SPORTON International Inc.***

***No. 52, Hwa Ya 1<sup>st</sup> Rd., Hwa Ya Technology Park, Kwei-Shan Hsiang, Tao Yuan Hsien, Taiwan, R.O.C.***

## Table of Contents

<b>History of This Test Report .....</b>	<b>ii</b>
<b>CERTIFICATE OF COMPLIANCE .....</b>	<b>1</b>
<b>1. General Description of Equipment under Test.....</b>	<b>2</b>
1.1 Applicant .....	2
1.2 Manufacturer .....	2
1.3 Basic Description of Equipment under Test.....	2
1.4 Feature of Equipment under Test .....	3
<b>2. Test Configuration of Equipment under Test.....</b>	<b>4</b>
2.1 Test Manner .....	4
2.2 Description of Test System .....	5
2.3 Connection Diagram of Test System .....	5
<b>3. Test Software .....</b>	<b>6</b>
<b>4. General Information of Test .....</b>	<b>7</b>
4.1 Test Facility .....	7
4.2 Test Voltage.....	7
4.3 Standard for Methods of Measurement .....	7
4.4 Test Compliance .....	7
4.5 Frequency Range .....	7
4.6 Test Distance .....	7
<b>5. Test of Conducted Powerline .....</b>	<b>8</b>
5.1 Major Measuring Instruments .....	8
5.2 Test Procedures.....	8
5.3 Typical Test Setup Layout of Conducted Powerline .....	9
5.4 Test Result of AC Powerline Conducted Emission .....	10
5.5 Photographs of Conducted Powerline Test Configuration .....	20
<b>6. Test of Radiated Emission .....</b>	<b>21</b>
6.1 Major Measuring Instruments .....	21
6.2 Test Procedures.....	21
6.3 Typical Test Setup Layout of Radiated Emission .....	22
6.4 Test Result of Radiated Emission.....	23
6.5 Photographs of Radiated Emission Test Configuration .....	34
<b>7. List of Measuring Equipment .....</b>	<b>35</b>
<b>8. Uncertainty of Evaluation .....</b>	<b>36</b>
<b>9. Certification of NVLAP Accreditation .....</b>	<b>38</b>
<b>Appendix A. Photographs of EUT</b>	
<b>Appendix B. Setup Photographs</b>	

### History of This Test Report

Report Issue Date: Apr. 14, 2008

Report No.	Description

## CERTIFICATE OF COMPLIANCE

According to

### 47 CFR Part 15 Subpart B

Equipment : EDA (Enterprise Digital Assistant)

Trade Name : Symbol

Model No. : MC5574

FCC ID : H9PMC5574

Applicant : Symbol Technologies Inc

One Symbol Plaza Holtsville, NY 11742 -1300 United States

I **HEREBY** CERTIFY THAT:

The measurements shown in this test report were made in accordance with the procedures given in ANSI C63.4 - 2003 and the energy emitted by this equipment was *passed* FCC Part 15 B, radiated and conducted emission class B limits. Testing was carried out on Apr. 08, 2008 at SPORTON International Inc. LAB.

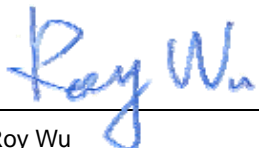

Roy Wu  
Manager

**SPORTON International Inc.**

**No. 52, Hwa Ya 1<sup>st</sup> Rd., Hwa Ya Technology Park, Kwei-Shan Hsiang, Tao Yuan Hsien, Taiwan, R.O.C.**

# 1. General Description of Equipment under Test

## 1.1 Applicant

Symbol Technologies Inc  
 One Symbol Plaza Holtsville, NY 11742 -1300 United States

## 1.2 Manufacturer

ASKEY COMPUYER CORP  
 10F, No. 119, CHIENKANG RD., CHUNG-HO, TAIPEI, TAIWAN, 235, R.O.C

## 1.3 Basic Description of Equipment under Test

<b>Equipment</b>		EDA (Enterprise Digital Assistant)
<b>Trade Name</b>		Symbol
<b>Model Name</b>		MC5574
<b>FCC ID</b>		H9PMC5574
<b>Sample A</b>		1D scanner without camera
<b>Sample B</b>		2D scanner without camera
<b>Sample C</b>		1D scanner with camera
<b>Sample D</b>		2D scanner with camera
<b>AC Adapter</b>	<b>Brand Name</b>	DELTA
	<b>Model Name</b>	ADP-16GB
	<b>Power Rating</b>	I/P: 100-240Vac, 50-60Hz, 0.4A; O/P: 5.4Vdc, 3A
	<b>AC Power Cord Type</b>	AC: 1.8 meter non-shielded cable with ferrite core DC: 1.8 meter non-shielded cable without ferrite core
<b>Battery</b>	<b>Brand Name</b>	SYMBOL
	<b>Part Number</b>	82-107172-01 Rev A
	<b>Power Rating</b>	3.7Vdc, 2400mAh
	<b>Type</b>	Li-ion
<b>Communication USB charge cable</b>	<b>Brand Name</b>	SYMBOL
	<b>Part Number</b>	25-108022-01R Rev. 1
	<b>Signal Line Type</b>	1.5 meter shielded cable without ferrite core

Remark: Above EUT's information was declared by manufacturer. Please refer to specifications of manufacturer or User's Manual for more detailed features description.

**1.4 Feature of Equipment under Test**

Product Feature & Specification	
<b>DUT Type :</b>	EDA (Enterprise Digital Assistant)
<b>Trade Name :</b>	Symbol
<b>Model Name :</b>	MC5574
<b>FCC ID :</b>	H9PMC5574
<b>Tx Frequency :</b>	GSM850 : 824 MHz ~ 849 MHz GSM1900 : 1850 MHz ~1910 MHz Bluetooth : 2400 MHz ~ 2483.5 MHz WLAN : 2400 MHz ~ 2483.5 MHz
<b>Rx Frequency :</b>	GSM850 : 869 MHz ~ 894 MHz GSM1900 : 1930 MHz ~ 1990 MHz Bluetooth : 2400 MHz ~ 2483.5 MHz WLAN : 2400 MHz ~ 2483.5 MHz
<b>Maximum Output Power to Antenna :</b>	GSM850 : 32.43 dBm (GSM) / 32.41 dBm (GPRS8) / 30.62 dBm (GPRS10) / 26.87 dBm (GPRS12) / 25.94 dBm (EGPRS8) / 23.83 dBm (EGPRS10) / 19.67 dBm (EGPRS12) / GSM1900 : 29.50 dBm (GSM) / 29.39 dBm (GPRS8) / 27.55 dBm (GPRS10) / 23.79 dBm (GPRS12) / 25.06 dBm (EGPRS8) / 23.26 dBm (EGPRS10) / 19.22 dBm (EGPRS12) / Bluetooth : 4.76 dBm WLAN : 14.57 dBm (802.11b) / 15.52 dBm (802.11g)
<b>Antenna Type :</b>	GSM : PIFA Antenna Bluetooth : Chip antenna WLAN : PIFA Antenna
<b>Antenna Gain :</b>	Bluetooth : -0.94 dBi WLAN : 1.22 dBi
<b>Power Rating (DC/AC , Voltage and Current of RF element or PA) :</b>	GSM : DC 3.8V / 2A
<b>GPRS / EGPRS Multislot class :</b>	12
<b>Type of Modulation :</b>	GSM / GPRS : GMSK EDGE : 8PSK Bluetooth : GFSK WLAN : DSSS / OFDM
<b>DUT Stage :</b>	Identical Prototype

## 2. Test Configuration of Equipment under Test

### 2.1 Test Manner

- a. The EUT has been setup pursuant to ANSI C63.4-2003 and configuration operated in a manner which tended to maximize its emission characteristics in a typical application.
- b. The complete test system refers to 2.2 for EMI test.
- c. The following test modes were tested for conduction test:
  - Mode 1 : GSM850 Idle + BT Idle + WLAN Idle + Adapter + USB Link + GPS Rx + MPEG 4 + Scanner for Sample A
  - Mode 2 : GSM850 Idle + BT Idle + WLAN Idle + Adapter + USB Link + GPS Rx + MPEG 4 + Scanner for Sample B
  - Mode 3 : EDGE Idle + BT Idle + WLAN Idle + Adapter + USB Link + GPS Rx + MPEG 4 for Sample C
  - Mode 4 : GSM850 Idle + BT Idle + WLAN Idle + Adapter + USB Link + GPS Rx + MPEG 4 + Camera for Sample D
  - Mode 5 : GSM1900 Idle + BT Idle + WLAN Idle + Adapter + USB Link + GPS Rx + MPEG 4 + Scanner for Sample D
- d. The following test modes were tested for radiation test:
  - Mode 1 : GSM850 Idle + BT Idle + WLAN Idle + Adapter + USB Link + GPS Rx + MPEG 4 + Scanner for Sample A
  - Mode 2 : GSM850 Idle + BT Idle + WLAN Idle + Adapter + USB Link + GPS Rx + MPEG 4 + Scanner for Sample B
  - Mode 3 : EDGE Idle + BT Idle + WLAN Idle + Adapter + USB Link + GPS Rx + MPEG 4 for Sample C
  - Mode 4 : GSM850 Idle + BT Idle + WLAN Idle + Adapter + USB Link + GPS Rx + MPEG 4 + Camera for Sample D
  - Mode 5 : GSM1900 Idle + BT Idle + WLAN Idle + Adapter + USB Link + GPS Rx + MPEG 4 + Scanner for Sample D
- e. Frequency range investigated: conduction 150 kHz to 30 MHz, radiation 30 MHz to 13 GHz.

## 2.2 Description of Test System

Item	Equipment	Trade Name	Model Name	FCC ID	Data Cable	Power Cord
1.	Base Station	R&S	CMU 200	N/A	N/A	Unshielded, 1.8 m
2.	GPS Station	T&E	GS-50	N/A	N/A	Unshielded, 1.8 m
3.	WLAN AP	SMC	SMC-100	HEDWG4005ACC	N/A	Unshielded, 1.8 m
4.	Notebook	DELL	D400	E2K24GBRL	N/A	AC I/P: Unshielded, 1.2 m DC O/P: Shielded, 1.8 m
5.	Bluetooth Earphone	Engotech	ET-BH111	PQY471087	N/A	N/A
6.	RS-232 Mouse	State	MS-303	DoC	Unshielded, 1.2 m	N/A
7.	i-pod	Apple	A1199	DoC	Unshielded, 1.2 m	N/A

## 2.3 Connection Diagram of Test System

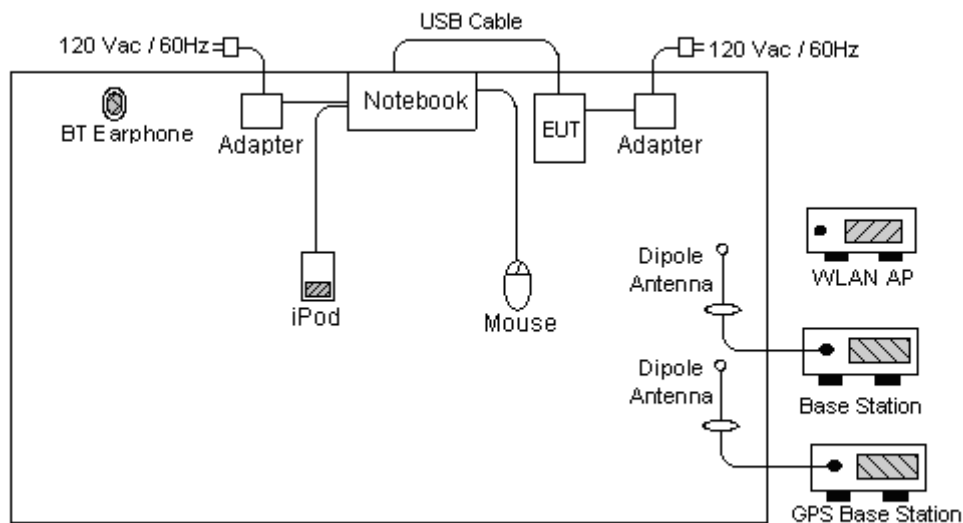



### 3. Test Software

In GSM or EDGE idle mode, the EUT is synchronized to the BCCH, and is in continuous receiving mode by setting system simulator's paging reorganization.

At the same time, the EUT was linked with Bluetooth earphone. For GPS function, the executive program, "VisualGPSce" make EUT receive signal from GPS station.

For associated equipment, the executive program, "EMCTest.exe" and "Activesync.exe" under WINXP installed in notebook generates a complete line of continuously repeating "H" pattern were used as the test software.

The programs were executed as follows:

- a. Turn on the power of all equipment.
- b. The notebook reads the test program from the hard disk drive and runs it.
- c. The notebook sends "H" messages to the panel, and the panel displays "H" patterns on the screen.
- d. The notebook sends "H" messages to the internal hard disk, and the hard disk reads and writes the message.
- e. Repeat the steps from b to d.

## 4. General Information of Test

### 4.1 Test Facility

Test Site Location : No. 52, Hwa Ya 1<sup>st</sup> Rd., Hwa Ya Technology Park,  
Kwei-Shan Hsiang, Tao Yuan Hsien, Taiwan, R.O.C.  
TEL : 886-3-327-3456  
FAX : 886-3-328-4978  
Test Site No. : CO01-HY, 03CH06-HY

### 4.2 Test Voltage

AC 120V / 60Hz

### 4.3 Standard for Methods of Measurement

ANSI C63.4-2003

### 4.4 Test Compliance

FCC Part 15 Subpart B

### 4.5 Frequency Range

- a. Conduction: from 150 kHz to 30 MHz
- b. Radiation: from 30 MHz to 13000MHz

### 4.6 Test Distance

The test distance of radiated emission from antenna to EUT is 3m.

## 5. Test of Conducted Powerline

Conducted Emissions were measured from 150 kHz to 30 MHz with a bandwidth of 9 kHz and return leads of the EUT according to the methods defined in ANSI C63.4-2003 Section 3.1. The EUT was placed on a nonmetallic stand in a shielded room 0.8 meters above the ground plane as shown in section 5.3. The interface cables and equipment positioning were varied within limits of reasonable applications to determine the position produced maximum conducted emissions.

### 5.1 Major Measuring Instruments

As described in Chapter 7.

### 5.2 Test Procedures

- a. The EUT was placed 0.4 meter from the conducting wall of the shielding room was kept at least 80 centimeters from any other grounded conducting surface.
- b. Connect EUT to the power mains through a line impedance stabilization network (LISN).
- c. All the support units are connecting to the other LISN.
- d. The LISN provides 50 ohm coupling impedance for the measuring instrument.
- e. The FCC states that a 50 ohm, 50 microhenry LISN should be used.
- f. Both sides of AC line were checked for maximum conducted interference.
- g. The frequency range from 150 kHz to 30 MHz was searched.
- h. Set the test-receiver system to Peak Detect Function and specified bandwidth with Maximum Hold Mode.

### 5.3 Typical Test Setup Layout of Conducted Powerline

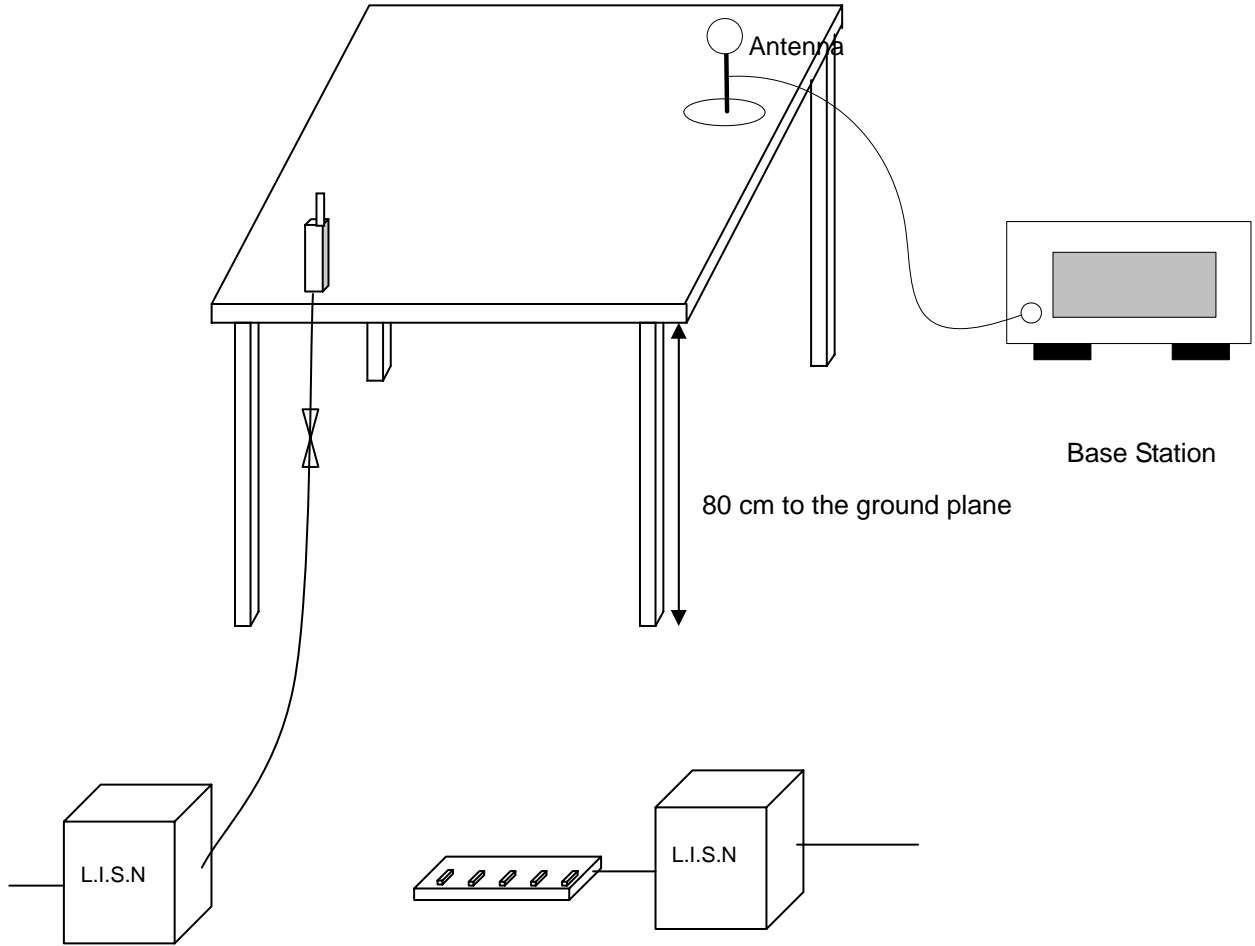

## 5.4 Test Result of AC Powerline Conducted Emission

### 5.4.1 Test Mode: Mode 1 – Sample A

- Frequency Range of Test: from 0.15 MHz to 30 MHz
- Temperature: 26~27
- Relative Humidity: 58~59%
- Test Engineer: Darren
- All emissions not reported here are more than 10 dB below the prescribed limit.

The test that passed at the minimum margin was marked by a frame in the following data

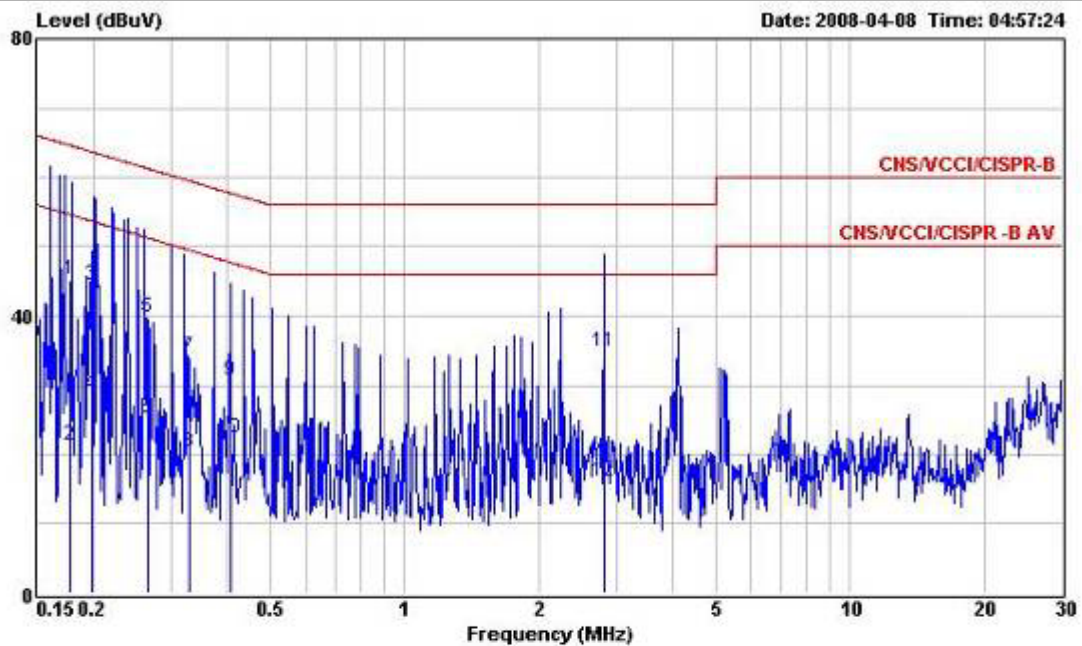

Site : C001-HY  
 Condition : CNS/VCCI/CISPR-B 2001/004 200604 LINE  
 EUT : MC5574 EV1 FCC submit with 1D 2D Scanner  
 : and w/ camera w/o camera  
 Power : 120V/60Hz  
 Model : FD840317  
 Memo : GSM850 Idle+BT Idle +WLAN Idle+Adaptor  
 Memo : + USB Link + MPEG4 + Scanner

	Freq	Level	Over	Limit	Read	Probe	Cable	
	MHz	dBuV	Limit	Line	Level	Factor	Loss	Remark
			dB	dBuV	dBuV	dB	dB	
1	0.178	45.27	-19.33	64.60	45.08	0.10	0.09	QP
2	0.178	21.31	-33.29	54.60	21.12	0.10	0.09	Average
3	0.199	44.54	-19.13	63.67	44.36	0.10	0.08	QP
4	0.199	28.49	-25.18	53.67	28.31	0.10	0.08	Average
5	0.265	39.70	-21.59	61.29	39.50	0.10	0.10	QP
6	0.265	25.15	-26.14	51.29	24.95	0.10	0.10	Average
7	0.329	34.09	-25.39	59.48	33.88	0.10	0.11	QP
8	0.329	20.27	-29.21	49.48	20.06	0.10	0.11	Average
9	0.407	30.58	-27.14	57.72	30.36	0.10	0.12	QP
10	0.407	22.32	-25.39	47.71	22.10	0.10	0.12	Average
11	2.801	34.70	-21.30	56.00	34.32	0.15	0.23	QP
12	2.801	16.08	-29.92	46.00	15.70	0.15	0.23	Average

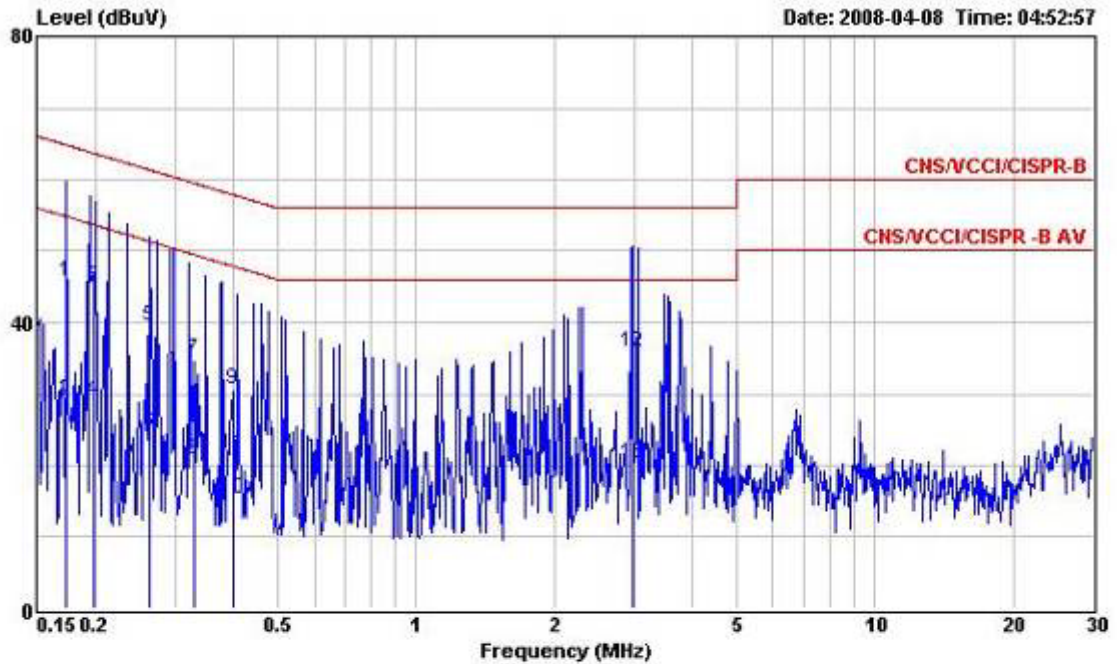

Site : CO01-HY  
 Condition : CNS/VCCI/CISPR-B 2001/004 200604 NEUTRAL  
 EUT : MC5574 EV1 FCC submit with 1D 2D Scanner  
 : and w/ camera w/o camera  
 Power : 120V/60Hz  
 Model : FD840317  
 Memo : GSM850 Idle+BT Idle +WLAN Idle+Adaptor  
 Memo : + USB Link + MPEG4 + Scanner

	Freq	Level	Over	Limit	Read	Probe	Cable	Remark
	MHz	dBuV	Limit	Line	Level	Factor	Loss	
			dB	dBuV	dBuV	dB	dB	
1	0.173	45.75	-19.07	64.82	45.56	0.10	0.09	QP
2	0.173	29.16	-25.66	54.82	28.97	0.10	0.09	Average
3	0.198	44.94	-18.75	63.69	44.76	0.10	0.08	QP
4	0.198	29.02	-24.67	53.69	28.84	0.10	0.08	Average
5	0.263	39.36	-21.98	61.34	39.16	0.10	0.10	QP
6	0.263	24.74	-26.60	51.34	24.54	0.10	0.10	Average
7	0.330	34.81	-24.65	59.46	34.60	0.10	0.11	QP
8	0.330	20.75	-28.71	49.46	20.54	0.10	0.11	Average
9	0.398	30.56	-27.34	57.90	30.34	0.10	0.12	QP
10	0.398	15.38	-32.52	47.90	15.16	0.10	0.12	Average
11	0.398	21.57	-36.33	57.90	21.35	0.10	0.12	QP
12	2.979	35.95	-20.05	56.00	35.60	0.10	0.25	QP
13	2.980	20.33	-25.67	46.00	19.98	0.10	0.25	Average

**5.4.2 Test Mode: Mode 2 – Sample B**

- Frequency Range of Test: from 0.15 MHz to 30 MHz
- Temperature: 26~27
- Relative Humidity: 58~59%
- Test Engineer: Darren
- All emissions not reported here are more than 10 dB below the prescribed limit.

**The test that passed at the minimum margin was marked by a frame in the following data**

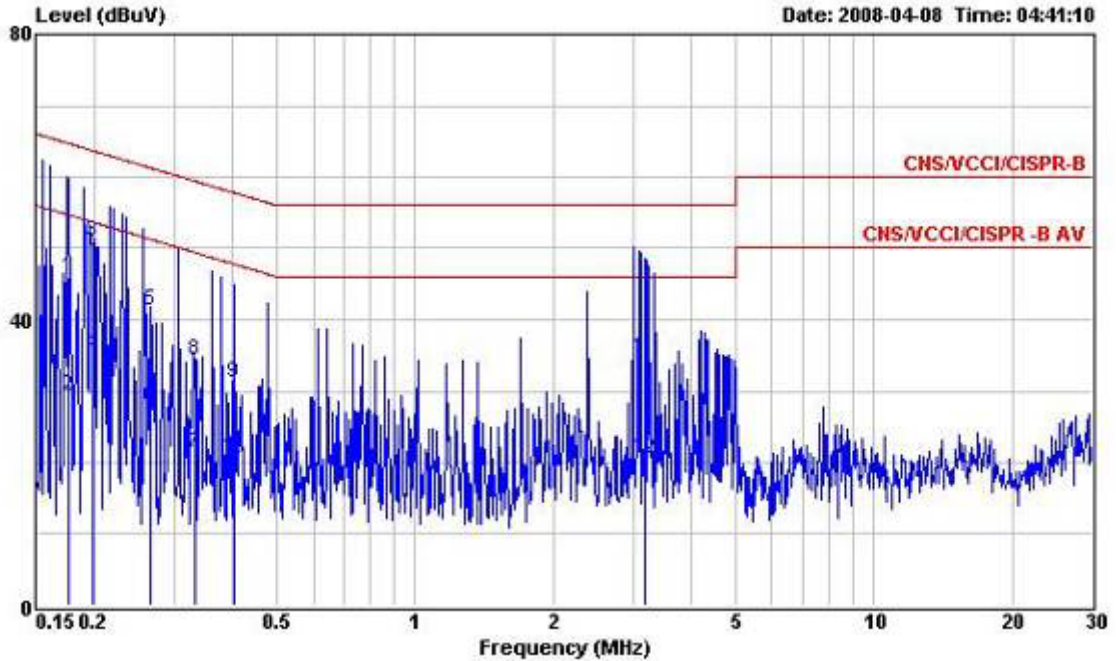

Site : CO01-HY  
 Condition : CNS/VCCI/CISPR-B 2001/004 200604 LINE  
 EUT : MC5574 EV1 FCC submit with 1D 2D Scanner  
 : and w/ camera w/o camera  
 Power : 120V/60Hz  
 Model : FD840317  
 Memo : GSM850 Idle+BT Idle + WLAN Idle+Adaptor  
 : + USB Link + MPEG4 + Scanner

	Freq	Level	Over	Limit	Read	Probe	Cable	
	MHz	dBuV	Limit	Line	Level	Factor	Loss	Remark
			dB	dBuV	dBuV	dB	dB	
1	0.175	45.91	-18.81	64.72	45.72	0.10	0.09	QP
2	0.175	29.31	-25.41	54.72	29.12	0.10	0.09	Average
3	0.198	50.84	-12.84	63.68	50.66	0.10	0.08	QP
4	0.198	35.14	-18.54	53.68	34.96	0.10	0.08	Average
5	0.266	41.22	-20.02	61.24	41.02	0.10	0.10	QP
6	0.266	27.77	-23.47	51.24	27.57	0.10	0.10	Average
7	0.333	21.33	-28.05	49.38	21.12	0.10	0.11	Average
8	0.333	34.25	-25.13	59.38	34.04	0.10	0.11	QP
9	0.403	31.28	-26.51	57.79	31.06	0.10	0.12	QP
10	0.403	20.42	-27.37	47.79	20.20	0.10	0.12	Average
11	3.170	34.50	-21.50	56.00	34.06	0.17	0.27	QP
12	3.170	20.44	-25.56	46.00	20.00	0.17	0.27	Average

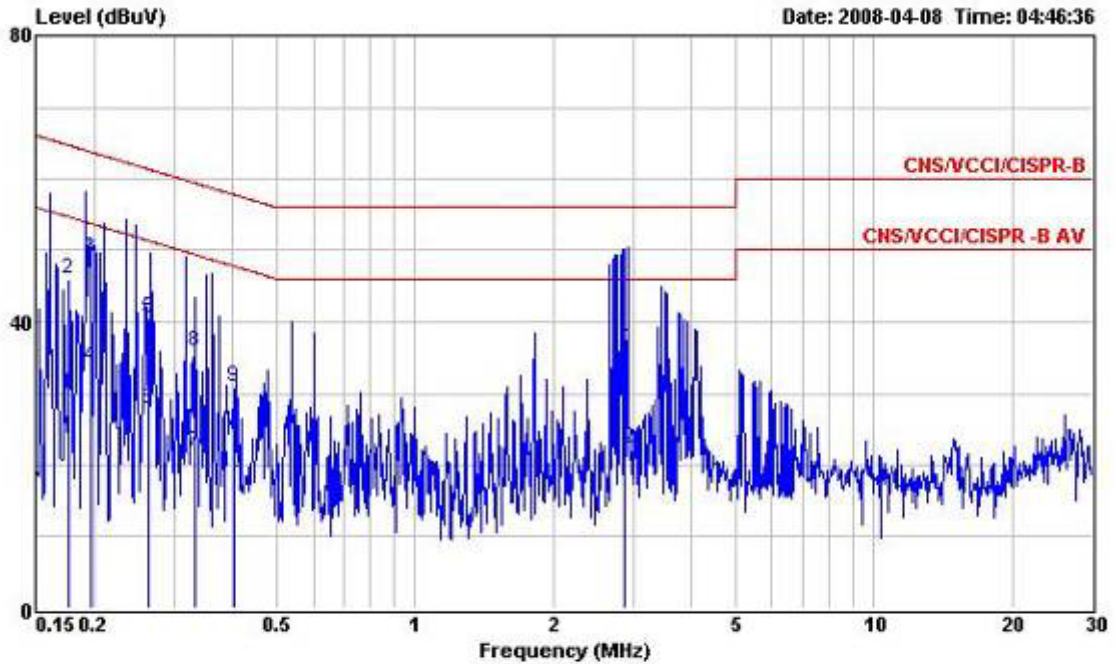

Site : CO01-HY  
 Condition : CNS/VCCI/CISPR-B 2001/004 200604 NEUTRAL  
 EUT : MC5574 EV1 FCC submit with 1D 2D Scanner  
 : and w/ camera w/o camera  
 Power : 120V/60Hz  
 Model : FD840317  
 Memo : GSM850 Idle+BT Idle + WLAN Idle+Adaptor  
 : + USB Link + MPEG4 + Scanner

	Freq	Level	ver	Limit	Read	Probe	Cable	
	MHz	dBuV	Limit	Line	Level	Factor	Loss	Remark
			dB	dBuV	dBuV	dB	dB	
1	0.175	29.88	-24.84	54.72	29.69	0.10	0.09	Average
2	0.175	45.93	-18.79	64.72	45.74	0.10	0.09	QP
3	0.196	48.74	-15.03	63.77	48.56	0.10	0.08	QP
4	0.196	33.71	-20.06	53.77	33.53	0.10	0.08	Average
5	0.263	40.56	-20.79	61.35	40.36	0.10	0.10	QP
6	0.263	27.89	-23.46	51.35	27.69	0.10	0.10	Average
7	0.332	21.88	-27.53	49.41	21.67	0.10	0.11	Average
8	0.332	35.75	-23.66	59.41	35.54	0.10	0.11	QP
9	0.403	31.02	-26.78	57.80	30.80	0.10	0.12	QP
10	0.403	18.90	-28.90	47.80	18.68	0.10	0.12	Average
11	2.850	36.32	-19.68	56.00	35.98	0.10	0.24	QP
12	2.850	22.47	-23.53	46.00	22.13	0.10	0.24	Average



**5.4.3 Test Mode: Mode 3 – Sample C**

- Frequency Range of Test: from 0.15 MHz to 30 MHz
- Temperature: 26~27
- Relative Humidity: 58~59%
- Test Engineer: Darren
- All emissions not reported here are more than 10 dB below the prescribed limit.

The test that passed at the minimum margin was marked by a frame in the following data

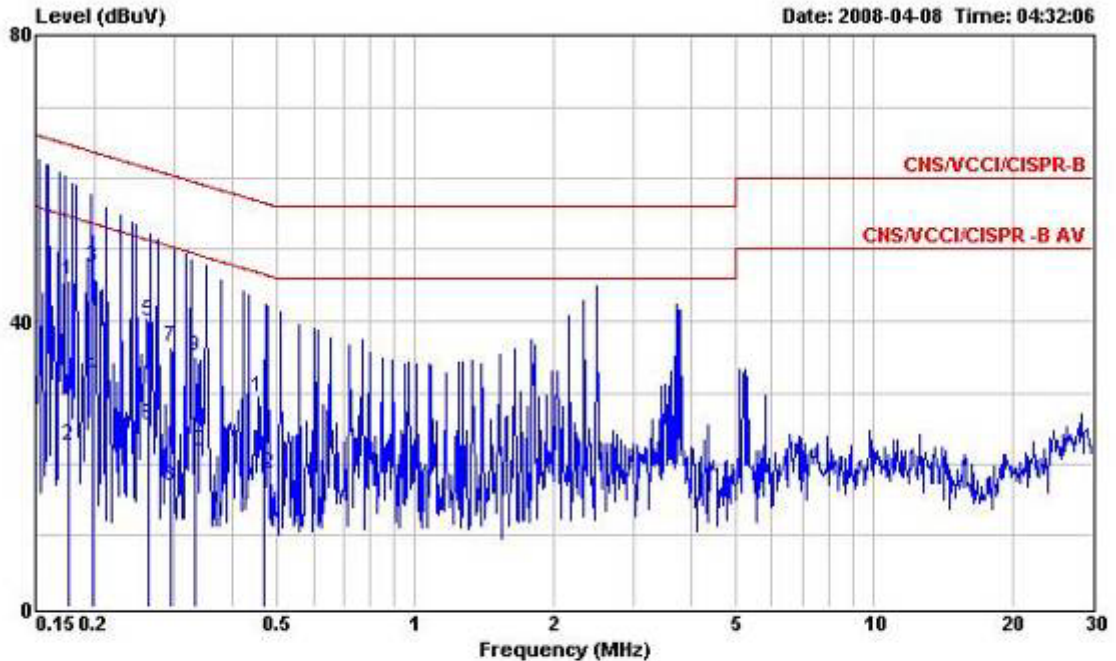

Site : CO01-HY  
 Condition : CNS/VCCI/CISPR-B 2001/004 200604 LINE  
 EUT : MC5574 EV1 FCC submit with 1D 2D Scanner  
 : and w/ camera w/o camera  
 Power : 120V/60Hz  
 Model : FD840317  
 Memo : EDGE Idle+BT Idle+WLAN Idle+Adaptor  
 Memo : + USB Link + MPEG4 + Scanner

	Freq	Level	Over	Limit	Read	Probe	Cable	
	MHz	dBuV	Limit	Line	Level	Factor	Loss	Remark
			dB	dBuV	dBuV	dB	dB	
1	0.176	45.75	-18.90	64.65	45.56	0.10	0.09	QP
2	0.176	22.64	-32.01	54.65	22.45	0.10	0.09	Average
3	0.199	47.44	-16.23	63.67	47.26	0.10	0.08	QP
4	0.199	32.21	-21.46	53.67	32.03	0.10	0.08	Average
5	0.264	39.90	-21.42	61.32	39.70	0.10	0.10	QP
6	0.264	25.46	-25.86	51.32	25.26	0.10	0.10	Average
7	0.294	36.42	-24.00	60.42	36.22	0.10	0.10	QP
8	0.294	17.00	-33.42	50.42	16.80	0.10	0.10	Average
9	0.332	34.99	-24.40	59.39	34.78	0.10	0.11	QP
10	0.332	21.70	-27.69	49.39	21.49	0.10	0.11	Average
11	0.467	29.27	-27.30	56.57	29.04	0.10	0.13	QP
12	0.467	18.66	-27.91	46.57	18.43	0.10	0.13	Average

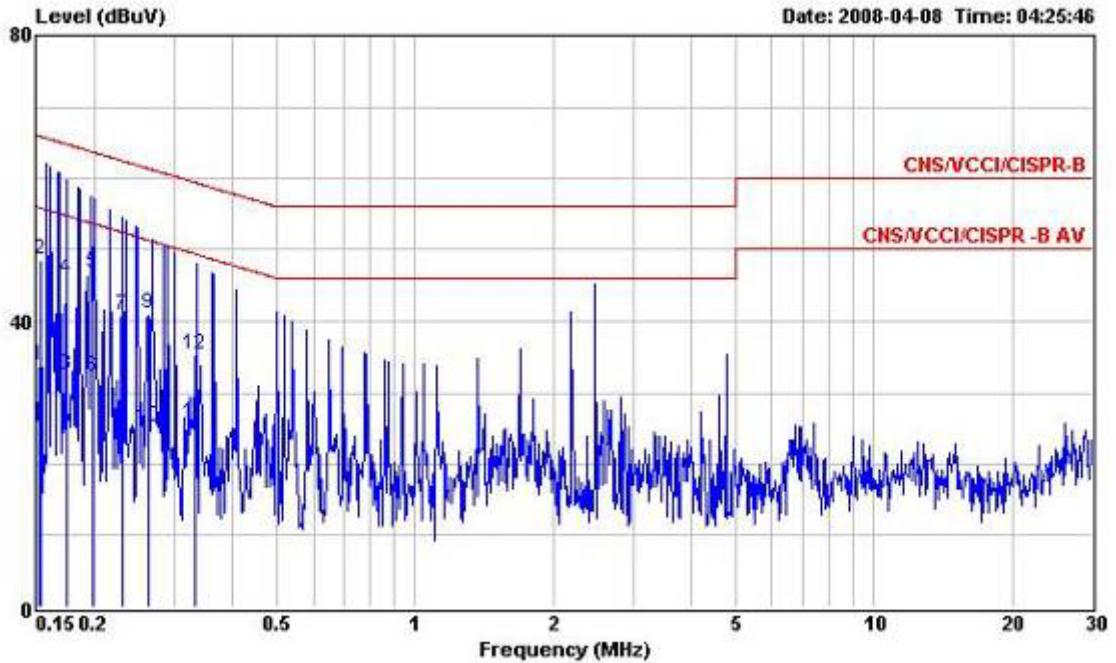

Site : CO01-HY  
 Condition : CNS/VCCI/CISPR-B 2001/004 200604 NEUTRAL  
 EUT : MC5574 EV1 FCC submit with 1D 2D Scanner  
 : and w/ camera w/o camera  
 Power : 120V/60Hz  
 Model : FD840317  
 Memo : EDGE Idle+BT Idle +WLAN Idle+Adaptor  
 : + USB Link + MPEG4 + Scanner

	Freq	Level	Over Limit	Limit Line	Read Level	Probe Factor	Cable Loss	Remark
	MHz	dBuV	dB	dBuV	dBuV	dB	dB	
1	0.152	33.85	-22.04	55.89	33.65	0.10	0.10	Average
2	0.152	48.48	-17.39	65.87	48.28	0.10	0.10	QP
3	0.174	32.48	-22.29	54.77	32.29	0.10	0.09	Average
4	0.174	46.03	-18.73	64.76	45.84	0.10	0.09	QP
5	0.199	46.80	-16.84	63.64	46.62	0.10	0.08	QP
6	0.199	32.21	-21.43	53.64	32.03	0.10	0.08	Average
7	0.231	40.67	-21.76	62.43	40.48	0.10	0.09	QP
8	0.231	24.84	-27.57	52.41	24.65	0.10	0.09	Average
9	0.264	41.04	-20.28	61.32	40.84	0.10	0.10	QP
10	0.264	25.31	-26.01	51.32	25.11	0.10	0.10	Average
11	0.332	25.84	-23.56	49.40	25.63	0.10	0.11	Average
12	0.332	35.43	-23.97	59.40	35.22	0.10	0.11	QP

**5.4.4 Test Mode: Mode 4 – Sample D**

- Frequency Range of Test: from 0.15 MHz to 30 MHz
- Temperature: 26~27
- Relative Humidity: 58~59%
- Test Engineer: Darren
- All emissions not reported here are more than 10 dB below the prescribed limit.

**The test that passed at the minimum margin was marked by a frame in the following data**

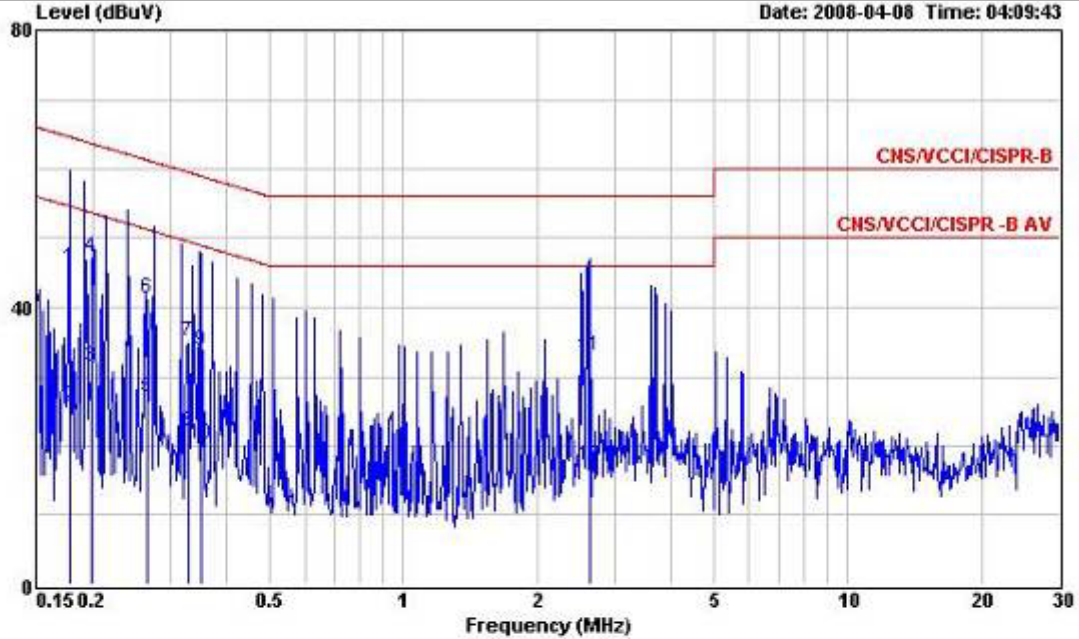

Site : C001-HY  
 Condition : CNS/VCCI/CISPR-B 2001.004 200604 LINE  
 EUT : MC5574 EV1 FCC submit with 1D 2D Scanner  
 : and w/ camera w/o camera  
 Power : 120V/60Hz  
 Model : FD840317  
 Memo : GSM850 Idle+BT Idle + WLAN Idle+Adaptor  
 : + USB Link + MPEG4 + Camera

	Freq	Level	Over Limit	Limit Line	Read Level	Probe Factor	Cable Loss	Remark
	MHz	dBuV	dB	dBuV	dBuV	dB	dB	
1	0.178	45.61	-18.97	64.58	45.42	0.10	0.09	QP
2	0.178	25.79	-28.79	54.58	25.60	0.10	0.09	Average
3	0.199	31.46	-22.20	53.66	31.28	0.10	0.08	Average
4	0.199	47.28	-16.38	63.66	47.10	0.10	0.08	QP
5	0.264	26.89	-24.41	51.30	26.69	0.10	0.10	Average
6	0.264	41.32	-19.98	61.30	41.12	0.10	0.10	QP
7	0.330	35.13	-24.33	59.46	34.92	0.10	0.11	QP
8	0.330	22.16	-27.30	49.46	21.95	0.10	0.11	Average
9	0.352	33.67	-25.25	58.92	33.46	0.10	0.11	QP
10	0.352	20.20	-28.72	48.92	19.99	0.10	0.11	Average
11	2.628	33.01	-22.99	56.00	32.66	0.14	0.21	QP
12	2.628	17.15	-28.85	46.00	16.80	0.14	0.21	Average

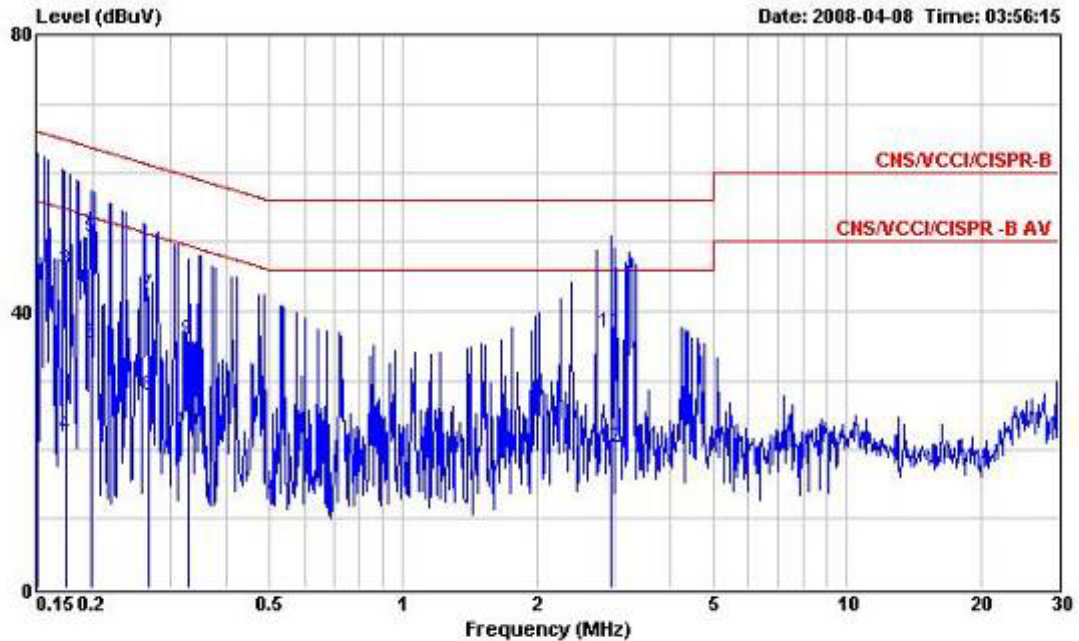

Site : CO01-HY  
 Condition : CNS/VCCI/CISPR-B 2001/004 200604 NEUTRAL  
 EUT : MC5574 EV1 FCC submit with 1D 2D Scanner  
 : and w/ camera w/o camera  
 Power : 120V/60Hz  
 Model : FD840317  
 Memo : GSM850 Idle+BT Idle+WLAN Idle+Adaptor  
 Memo : + USB Link + MPEG4 + Camera

	Freq	Level	Over	Limit	Read	Probe	Cable	
	MHz	dBuV	Limit	Line	Level	Factor	Loss	Remark
			dB	dBuV	dBuV	dB	dB	
1	0.150	48.74	-17.24	65.98	48.54	0.10	0.10	QP
2	0.150	20.26	-45.72	65.98	20.06	0.10	0.10	Average
3	0.175	46.07	-18.67	64.74	45.88	0.10	0.09	QP
4	0.175	22.20	-42.54	64.74	22.01	0.10	0.09	Average
5	0.198	50.74	-12.94	63.68	50.56	0.10	0.08	QP
6	0.198	35.24	-28.44	63.68	35.06	0.10	0.08	Average
7	0.267	42.26	-18.97	61.23	42.06	0.10	0.10	QP
8	0.267	27.77	-33.46	61.23	27.57	0.10	0.10	Average
9	0.329	35.75	-23.73	59.48	35.54	0.10	0.11	QP
10	0.329	22.55	-36.93	59.48	22.34	0.10	0.11	Average
11	2.950	36.87	-19.13	56.00	36.52	0.10	0.25	QP
12	2.950	20.35	-35.65	56.00	20.00	0.10	0.25	Average

**5.4.5 Test Mode: Mode 5 – Sample D**

- Frequency Range of Test: from 0.15 MHz to 30 MHz
- Temperature: 26~27
- Relative Humidity: 58~59%
- Test Engineer: Darren
- All emissions not reported here are more than 10 dB below the prescribed limit.

**The test that passed at the minimum margin was marked by a frame in the following data**

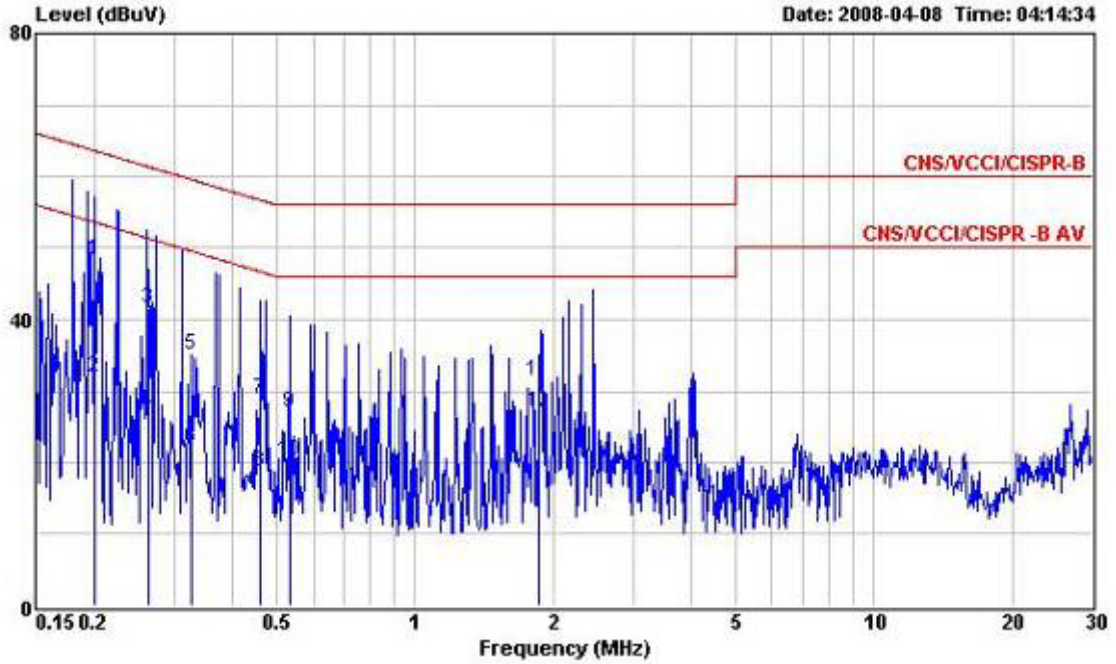

Site : CO01-HY  
 Condition : CNS/VCCI/CISPR-B 2001/004 200604 LINE  
 EUT : MC5574 EV1 FCC submit with 1D 2D Scanner  
 : and w/ camera w/o camera  
 Power : 120V/60Hz  
 Model : FD840317  
 Memo : PCS1900 Idle+BT Idle +WLAN Idle+Adaptor  
 Memo : + USB Link + MPEG4 + Scanner

	Freq	Level	Over	Limit	Read	Probe	Cable	
	MHz	dBuV	Limit	Line	Level	Factor	Loss	Remark
			dB	dBuV	dBuV	dB	dB	
1	0.200	48.40	-15.23	63.63	48.22	0.10	0.08	QP
2	0.200	32.06	-21.57	53.63	31.88	0.10	0.08	Average
3	0.262	41.44	-19.93	61.37	41.24	0.10	0.10	QP
4	0.262	27.02	-24.35	51.37	26.82	0.10	0.10	Average
5	0.327	34.95	-24.59	59.54	34.74	0.10	0.11	QP
6	0.327	22.05	-27.49	49.54	21.84	0.10	0.11	Average
7	0.459	28.85	-27.85	56.70	28.62	0.10	0.13	QP
8	0.459	18.75	-27.95	46.70	18.52	0.10	0.13	Average
9	0.532	26.90	-29.10	56.00	26.66	0.10	0.14	QP
10	0.532	20.14	-25.86	46.00	19.90	0.10	0.14	Average
11	1.868	31.45	-24.55	56.00	31.22	0.10	0.13	QP
12	1.868	27.05	-18.95	46.00	26.82	0.10	0.13	Average

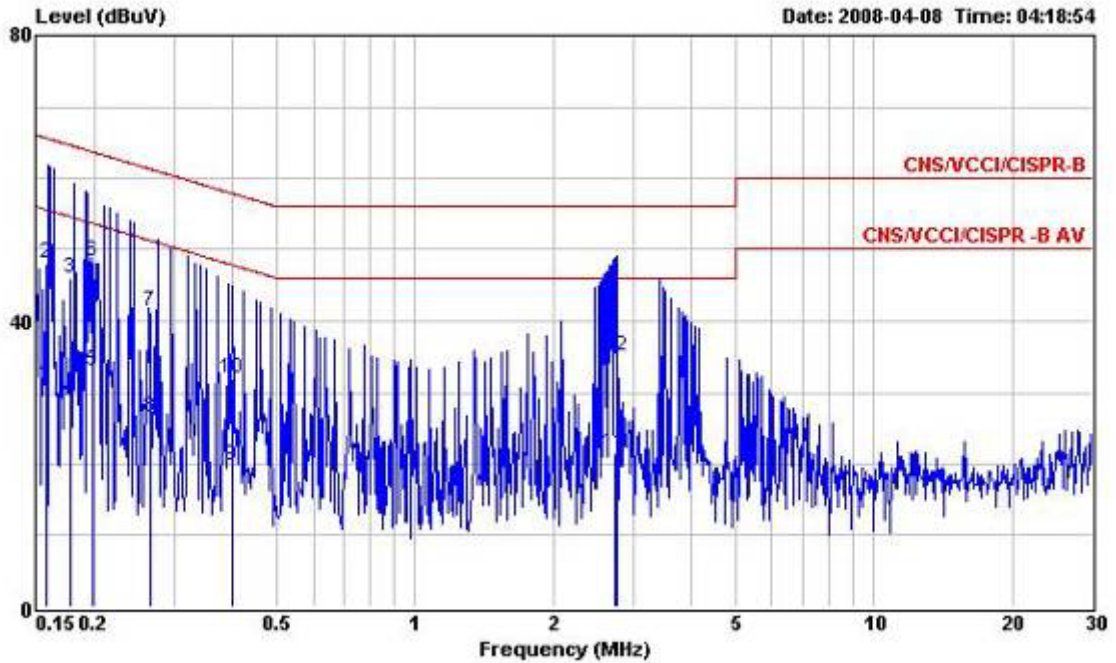

Site : CO01-HY  
 Condition : CNS/VCCI/CISPR-B 2001/004 200604 NEUTRAL  
 EUT : MC5574 EV1 FCC submit with 1D 2D Scanner  
 : and w/ camera w/o camera  
 Power : 120V/60Hz  
 Model : FD840317  
 Memo : PCS1900 Idle+BT Idle +WLAN Idle+Adaptor  
 : + USB Link + MPEG4 + Scanner

	Freq	Level	Over Limit	Limit Line	Read Level	Probe Factor	Cable Loss	Remark
	MHz	dBuV	dB	dBuV	dBuV	dB	dB	
1	0.157	31.19	-24.43	55.62	31.00	0.10	0.09	Average
2	0.157	47.93	-17.67	65.60	47.74	0.10	0.09	QP
3	0.177	45.85	-18.79	64.64	45.66	0.10	0.09	QP
4	0.177	29.09	-25.54	54.63	28.90	0.10	0.09	Average
5	0.199	33.02	-20.65	53.67	32.84	0.10	0.08	Average
6	0.199	48.26	-15.41	63.67	48.08	0.10	0.08	QP
7	0.265	41.40	-19.88	61.28	41.20	0.10	0.10	QP
8	0.265	26.49	-24.79	51.28	26.29	0.10	0.10	Average
9	0.400	19.84	-28.01	47.85	19.62	0.10	0.12	Average
10	0.400	32.00	-25.85	57.85	31.78	0.10	0.12	QP
11	2.740	21.56	-24.44	46.00	21.23	0.10	0.23	Average
12	2.743	35.03	-20.97	56.00	34.70	0.10	0.23	QP



## 5.5 Photographs of Conducted Powerline Test Configuration

Please refer to Appendix B

## 6. Test of Radiated Emission

Radiated emissions from 30 MHz to 13 GHz were measured with a bandwidth of 120 kHz and 1MHz according to the methods defines in ANSI C63.4-2003. The EUT was placed on a nonmetallic stand, 0.8 meter above the ground plane, as shown in section 6.3. The interface cables and equipment positions were varied within limits of reasonable applications to determine the positions producing maximum radiated emissions.

### 6.1 Major Measuring Instruments

As described in Chapter 7.

### 6.2 Test Procedures

- a. The EUT was placed on a turntable with 0.8 meter above ground.
- b. The EUT was set 3 meters from the interference receiving antenna which was mounted on the top of a variable height antenna tower.
- c. The table was rotated 360 degrees to determine the position of the highest radiation.
- d. The antenna is a Bi-Log antenna and its height is varied between one meter and four meters above ground to find the maximum value of the field strength both for horizontal polarization and vertical polarization of the antenna.
- e. For each suspected emission the EUT was arranged to its worst case and then tune the antenna tower (from 1 m to 4 m) and turntable (from 0 degree to 360 degrees) to find the maximum reading.
- f. Set the test-receiver system to Peak Detect Function and specified bandwidth with Maximum Hold Mode.
- g. If the emission level of the EUT in peak mode was 3 dB lower than the limit specified, then testing will be stopped and peak values of EUT will be reported, otherwise, the emissions will be repeated one by one using the quasi-peak method and reported.



### 6.3 Typical Test Setup Layout of Radiated Emission

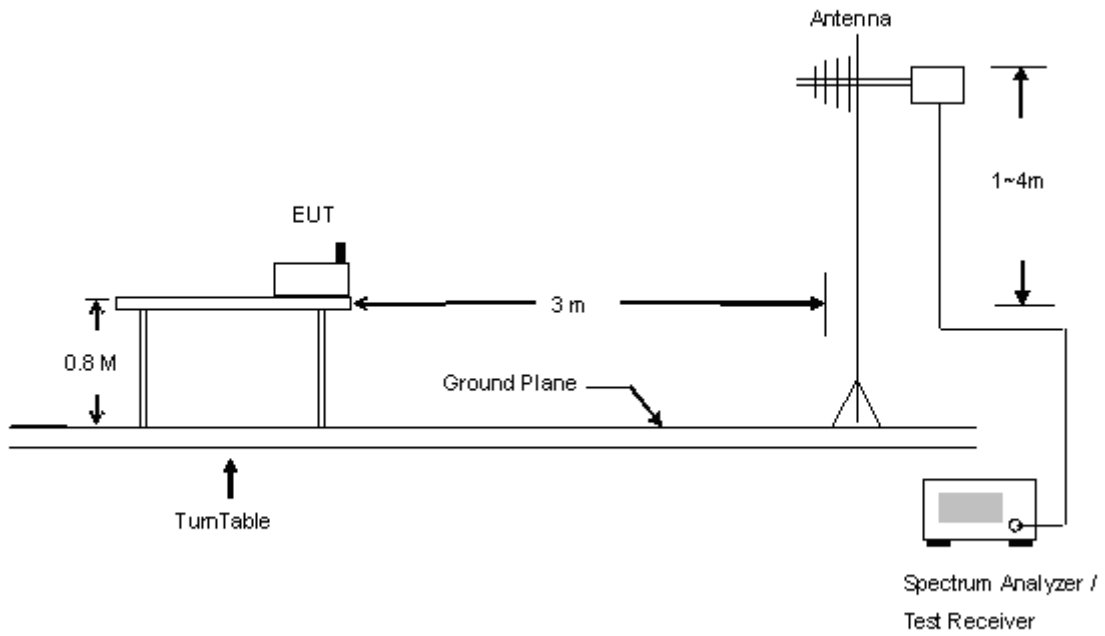

## 6.4 Test Result of Radiated Emission

### 6.4.1 Test Mode: Mode 1 – Sample A

- Test Distance: 3m
- Temperature: 21~26°C
- Relative Humidity: 51~58%
- Emission level (dBuV/m) = 20 log Emission level (uV/m)
- Test Engineer: Sun
- Corrected Reading: Probe Factor + Cable Loss + Read Level - Preamp Factor = Level

The test that passed at the minimum margin was marked by a frame in the following data

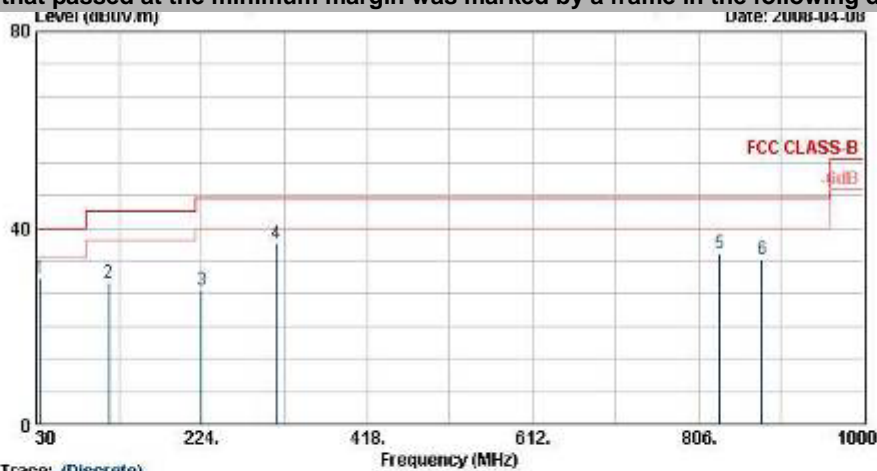

Site: 03CH06-RY  
 Condition: FCC CLASS-B 3m LP-ANT(951121) HORIZONTAL  
 EUT: MC5574 BYI FCC submit with 10 2D Scanner  
 Scanner and w/ camera w/o camera  
 Power: 120Vac/60Hz  
 Model: FD 840317  
 Mode: CSW850 Idle + BT Idle + WLAN Idle  
 + Adaptor + USB Link + GPS Rx + MP3Cd  
 + Scanner

	Freq	Level	Over	Limit	Read	Antenna	Cable	Preamp	Ant	Table	Remark
	MHz	dBuV/m	dB	dBuV/m	dBuV	dB/m	dB	dB	cm	deg	
1	34.59	29.72	-10.28	40.00	46.59	16.13	0.30	33.30	---	---	Peak
2	114.78	28.81	-14.69	43.50	49.73	12.13	0.50	33.55	---	---	Peak
3	223.58	27.25	-18.75	46.00	49.31	10.73	0.70	33.48	---	---	Peak
4	311.90	36.79	-9.21	46.00	55.76	13.53	0.80	33.30	100	182	Peak
5	831.30	34.81	-11.19	46.00	46.20	20.04	1.20	32.63	---	---	Peak
6	880.30	33.48	-12.52	46.00	44.54	20.38	1.30	32.75	---	---	Peak

Remark: The spurious emission above 1 GHz is too low to be taken.

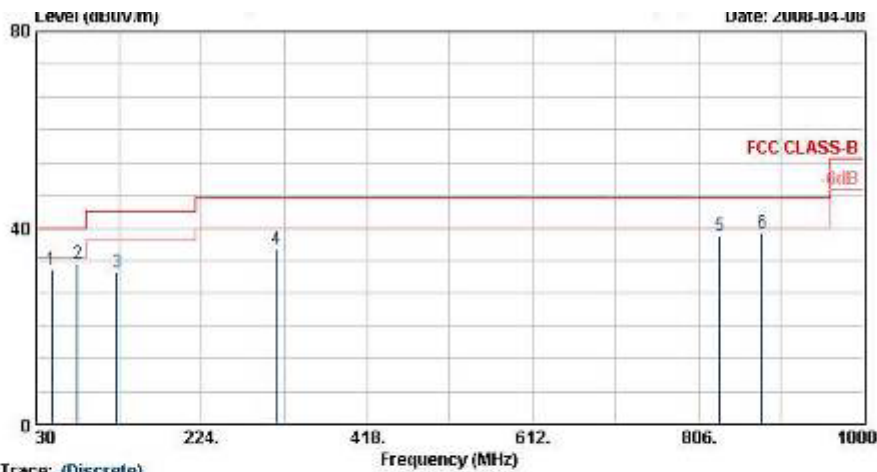

Site: 03CH06-WY  
 Condition: FCC CLASS-B 3m LF-ANT(851121) VERTICAL  
 EDT: #C5574 EYI FCC submit with 10 2D Scanner  
 Scanner and w/ camera w/o camera  
 Power: 120Vac/50Hz  
 Model: FD 840317  
 Mode: GSM850 Idle + BT Idle + WLAN Idle  
 + Adaptor + USB Link + GPS Rx + #PBG4  
 + Scanner

	Freq	Level	Over	Limit	ReadAntenna	Cable	Preamp	Ant	Table	Remark
	MHz	dBuV/m	Limit	Line	Level	Loss	Loss	Pos	Pos	
			dB	dBuV/m	dBuV	dB	dB	cm	deg	
1	48.09	31.51	-8.49	40.00	55.29	9.06	0.30	33.14	---	Peak
2	78.33	32.77	-7.23	40.00	58.34	7.41	0.47	33.44	100	Peak
3	124.77	30.84	-12.66	43.50	51.00	12.66	0.50	33.33	---	Peak
4	311.90	35.58	-10.42	46.00	54.56	13.53	0.80	33.30	---	Peak
5	831.30	38.33	-7.67	46.00	49.73	20.04	1.20	32.63	---	Peak
6	880.30	39.10	-6.90	46.00	50.16	20.39	1.30	32.75	---	Peak

Remark: The spurious emission above 1 GHz is too low to be taken.

**6.4.2 Test Mode: Mode 2 – Sample B**

- Test Distance: 3m
- Temperature: 21~26°C
- Relative Humidity: 51~58%
- Emission level (dBuV/m) = 20 log Emission level (uV/m)
- Test Engineer: Sun
- Corrected Reading: Probe Factor + Cable Loss + Read Level - Preamp Factor = Level

The test that passed at the minimum margin was marked by a frame in the following data

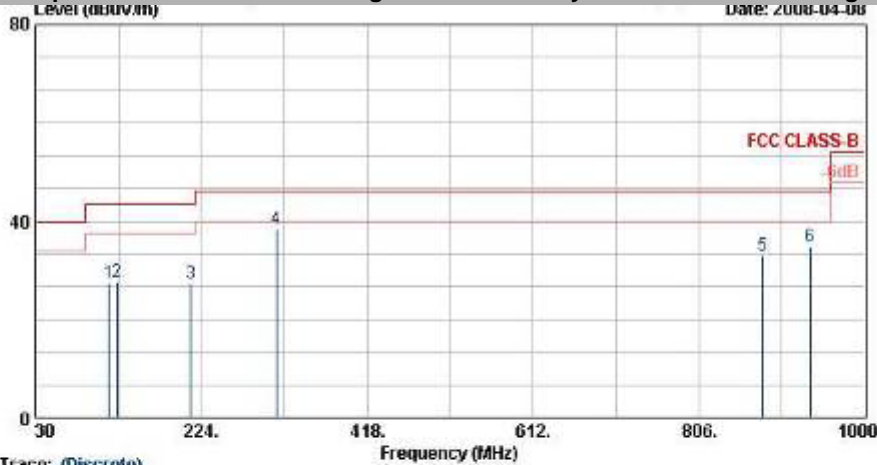

Site Condition EDT  
 Power Model Mode  
 Trace: (Discrete)  
 BSCR06-RV  
 FCC CLASS-B 3a LP-ANT(851121) HORIZONTAL  
 #C5574 EMI FCC submit with ID 2D Scanner  
 Scanner and w/ camera n/a camera  
 120Vac/60Hz  
 FD 840317  
 GSMR50 Idle + BT Idle + WLAN Idle  
 + Adaptor + USB Link + GPS Rx + MPEG4  
 + Scanner

	Freq	Level	Over	Limit	Read	Antenna	Cable	Preamp	Ant	Table	Remark
	MHz	dBuV/m	dB	dBuV/m	dBuV	dB/m	dB	dB	cm	deg	
1	115.59	27.24	-16.26	43.50	48.06	12.20	0.50	33.52	---	---	Peak
2	125.58	27.67	-15.83	43.50	47.98	12.50	0.50	33.31	---	---	Peak
3	211.44	27.41	-16.09	43.50	50.32	9.99	0.61	33.51	---	---	Peak
4	311.90	38.30	-7.70	46.00	57.27	13.53	0.80	33.30	100	196	Peak
5	880.30	33.05	-12.95	46.00	44.11	20.39	1.30	32.75	---	---	Peak
6	936.30	34.84	-11.16	46.00	45.39	20.79	1.20	32.54	---	---	Peak

Remark: The spurious emission above 1 GHz is too low to be taken.

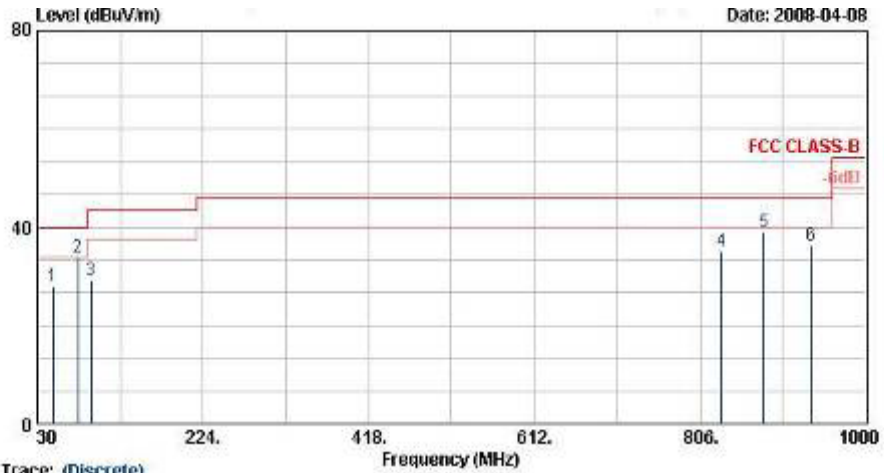

Trace: (Discrete)  
 Site: 09CH06-RY  
 Condition: FCC CLASS-B 3m LP-ANT(951121) VERTICAL  
 EUT: MC5574 RY1 FCC submit with ID 2D Scanner  
 Scanner and w/ camera w/o camera  
 Power: 120Vac/50Hz  
 Model: FD 840317  
 Mode: CSM850 Idle + BT Idle + WLAN Idle  
 + Adaptor + USB Link + GPS Rx + MPBCd  
 + Scanner

	Freq	Level	Over	Limit	ReadAntenna	Cable	Preamp	Ant	Table	Remark	
	MHz	dBuV/m	dB	dBuV/m	dBuV	dB/m	dB	dB	cm	deg	
1	48.09	27.87	-12.13	40.00	51.65	9.06	0.30	33.14	---	---	Peak
2	77.79	33.87	-6.13	40.00	59.54	7.35	0.45	33.47	100	211	Peak
3	92.64	29.15	-14.35	40.00	52.37	9.62	0.50	33.33	---	---	Peak
4	831.30	35.03	-10.97	46.00	46.43	20.04	1.20	32.63	---	---	Peak
5	880.30	38.91	-7.09	46.00	49.97	20.39	1.30	32.75	---	---	Peak
6	936.30	36.40	-9.60	46.00	46.95	20.79	1.20	32.54	---	---	Peak

Remark: The spurious emission above 1 GHz is too low to be taken.

**6.4.3 Test Mode: Mode 3 – Sample C**

- Test Distance: 3m
- Temperature: 21~26°C
- Relative Humidity: 51~58%
- Emission level (dBuV/m) = 20 log Emission level (uV/m)
- Test Engineer: Sun
- Corrected Reading: Probe Factor + Cable Loss + Read Level - Preamp Factor = Level

The test that passed at the minimum margin was marked by a frame in the following data

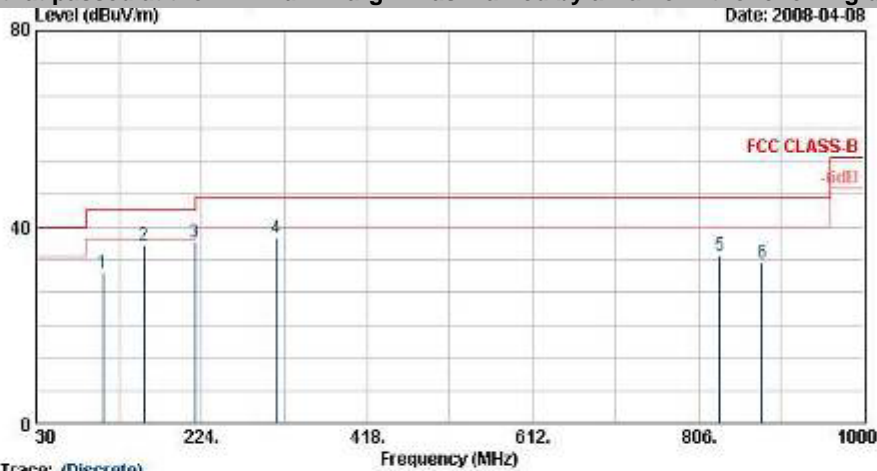

Site Condition: 00C06-RY  
 PCC CLASS-B 3m LF-ANT(951121) HORIZONTAL  
 MC5574 FYI PCC submit with ID 2D Scanner  
 Scanner and w/ camera w/o camera  
 Power: 120Vac/60Hz  
 Model: PD 840317  
 Mode: EDGE Idle + BT Idle + WLAN Idle  
 + Adaptor + USB Link + GPS Rx + MP3Cd  
 + Camera

	Freq	Level	Over	Limit	ReadAntenna	Cable	Preamp	Ant	Table	Remark
	MHz	dBuV/m	Limit	Line	Level	Loss	Factor	Pos	Pos	
			dB	dBuV/m	dBuV	dB	dB	cm	deg	
1	108.03	30.72	-12.78	43.50	52.21	11.80	0.50	33.59	---	Peak
2	156.09	36.27	-7.23	43.50	58.95	10.24	0.60	33.52	100	145 Peak
3	216.03	36.75	-9.25	46.00	59.32	10.27	0.66	33.50	---	Peak
4	311.90	37.87	-8.13	46.00	56.84	13.53	0.80	33.30	---	Peak
5	831.30	34.26	-11.74	46.00	45.65	20.04	1.20	32.63	---	Peak
6	880.30	32.69	-13.31	46.00	43.75	20.39	1.30	32.75	---	Peak

Remark: The spurious emission above 1 GHz is too low to be taken.

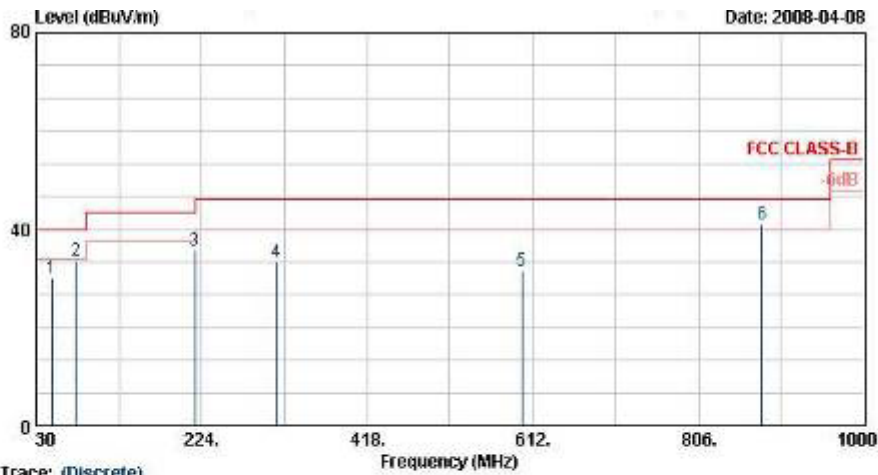

Trace: (Discrete)  
 Site: 00CR06-RY  
 Condition: FCC CLASS-B 3m LF-ANT(951121) VERTICAL  
 EUT: MC5574 EYI FCC submit with ID 2D Scanner  
 Scanner and w/ camera w/o camera  
 Power: 120Vac/60Hz  
 Model: PD 840317  
 Mode: EDGE Idle + BT Idle + WLAN Idle  
 + Adaptor + USB Link + GPS Rx + MPRGd  
 + Camera

	Freq	Level	Over	Limit	ReadAntenna	Cable	Preamp	Ant	Table	Remark
	MHz	dBuV/m	Limit	Line	Level	Loss	Loss	Pos	Pos	
			dB	dBuV/m	dBuV	dB	dB	cm	deg	
1	48.08	30.02	-9.98	40.00	53.79	9.06	0.30	33.14	---	Peak
2	78.98	33.50	-6.50	40.00	59.27	7.29	0.43	33.49	100	183 Peak
3	216.03	35.67	-10.33	46.00	58.24	10.27	0.66	33.50	---	Peak
4	311.90	33.21	-12.79	46.00	52.18	13.53	0.80	33.30	---	Peak
5	598.90	31.41	-14.59	46.00	44.83	18.45	1.00	32.87	---	Peak
6 @	880.30	41.02	-4.98	46.00	52.08	20.39	1.30	32.75	---	Peak

Remark: The spurious emission above 1 GHz is too low to be taken.

6.4.4 Test Mode: Mode 4 – Sample D

- Test Distance: 3m
- Temperature: 21~26°C
- Relative Humidity: 51~58%
- Emission level (dBuV/m) = 20 log Emission level (uV/m)
- Test Engineer: Sun
- Corrected Reading: Probe Factor + Cable Loss + Read Level - Preamp Factor = Level

The test that passed at the minimum margin was marked by a frame in the following data

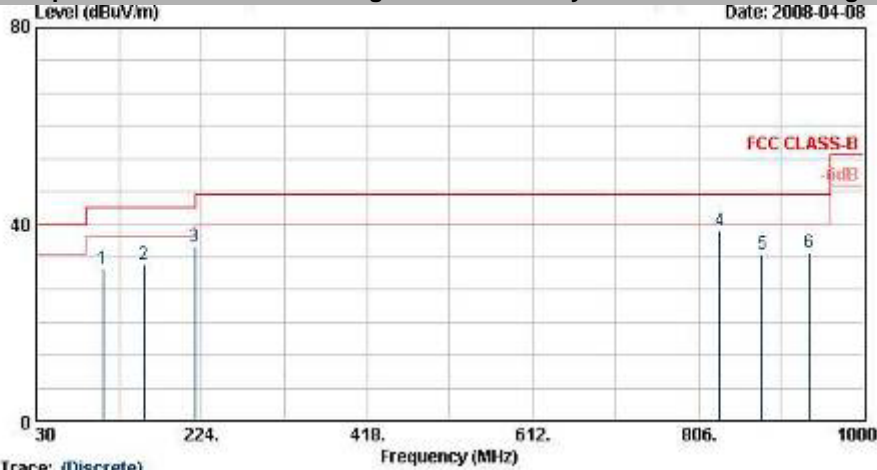

Site  
Condition  
EUT  
Power  
Model  
Mode

Trace: (Discrete)  
03CH06-RY  
FCC CLASS-B 3m LF-ANT(051121) HORIZONTAL  
MC5574 EYI FCC submit with ID 2D Scanner  
Scanner and w/ camera w/o camera  
120Vac/60Hz  
FD 840317  
CS2050 Idle + BT Idle + WLAN Idle  
+ Adaptor + USB Link + GPS Rx + MP3Cd  
+ Camera

	Freq MHz	Level dBuV/m	Over Limit dB	Limit Line dBuV/m	ReadAntenna Level dBuV	Antenna Factor dB/m	Cable Loss dB	Preamp Factor dB	Ant Pos cm	Table Pos deg	Remark
1	108.03	31.03	-12.47	43.50	52.53	11.80	0.50	33.59	---	---	Peak
2	156.09	31.82	-11.68	43.50	54.50	10.24	0.60	33.52	100	210	QP
3	216.03	35.34	-10.66	46.00	57.91	10.27	0.66	33.50	---	---	Peak
4	831.30	38.68	-7.32	46.00	50.07	20.04	1.20	32.63	100	179	Peak
5	880.30	33.85		46.00	44.91	20.39	1.30	32.75	---	---	Peak
6	936.30	34.10	-11.90	46.00	44.66	20.79	1.20	32.54	---	---	Peak

Remark: #5 is BS BCCH Signal.



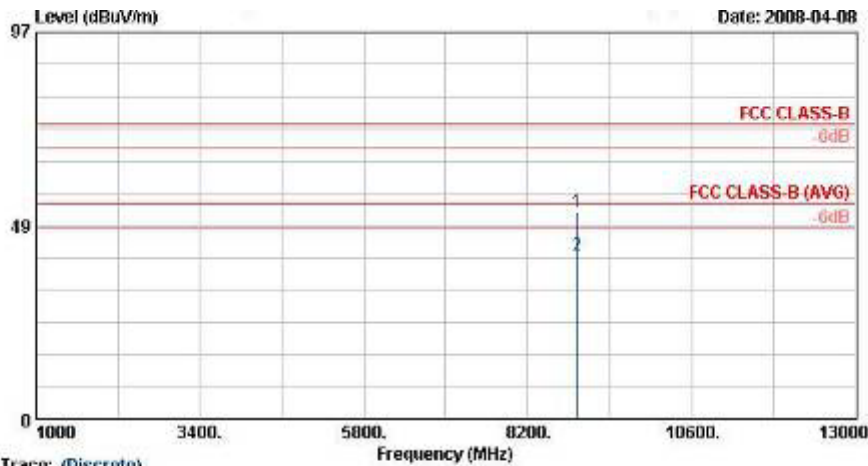

Trace: (Discrete)  
 Site : 03CH06-WY  
 Condition : FCC CLASS-B 9a HP-ANT(0-16)-080918 HORIZONTAL  
 EUT : MCS574 EMI FCC subunit with 1D 2D Scanner  
 Scanner and w/ camera w/o camera  
 Power : 120Vac/60Hz  
 Model : FD 840317  
 Mode : GSM850 Idle + BT Idle + WLAN Idle  
 + Adaptor + USB Link + GPS Rx + MPRCA  
 + Camera

	Freq	Level	Over Limit	Limit Line	ReadAntenna Level	Antenna Factor	Cable Loss	Preamp Factor	Ant Pos	Table Pos	Remark
	MHz	dBUV/m	dB	dBUV/m	dBuV	dB/m	dB	dB	cm	deg	
1	8918.00	51.93	-22.07	74.00	44.39	36.38	7.71	36.56	100	0	Peak
2	8918.00	41.10	-12.90	54.00	33.56	36.38	7.71	36.56	100	216	Average

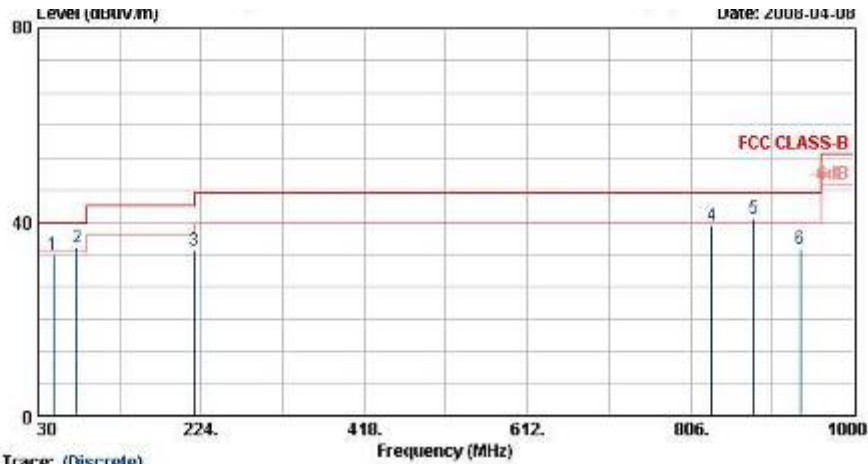

Trace: (Discrete)  
 Site : 03CH06-WY  
 Condition : FCC CLASS-B 9a LP-ANT(051121) VERTICAL  
 EUT : MCS574 EMI FCC subunit with 1D 2D Scanner  
 Scanner and w/ camera w/o camera  
 Power : 120Vac/60Hz  
 Model : FD 840317  
 Mode : GSM850 Idle + BT Idle + WLAN Idle  
 + Adaptor + USB Link + GPS Rx + MPRCA  
 + Camera

	Freq	Level	Over Limit	Limit Line	ReadAntenna Level	Antenna Factor	Cable Loss	Preamp Factor	Ant Pos	Table Pos	Remark
	MHz	dBUV/m	dB	dBUV/m	dBuV	dB/m	dB	dB	cm	deg	
1	48.09	33.32	-6.68	40.00	57.09	9.06	0.30	33.14	---	---	Peak
2 @	76.44	34.69	-5.31	40.00	60.46	7.29	0.43	33.49	100	208	Peak
3	216.03	34.06	-11.94	46.00	56.63	10.27	0.66	33.50	---	---	Peak
4	831.30	39.13	-6.87	46.00	50.52	20.04	1.20	32.63	---	---	Peak
5 !	880.30	40.67			51.73	20.39	1.30	32.75	---	---	Peak
6	936.30	34.69	-11.41	46.00	45.14	20.79	1.20	32.64	---	---	Peak

Remark: #5 is BS BCCH Signal.

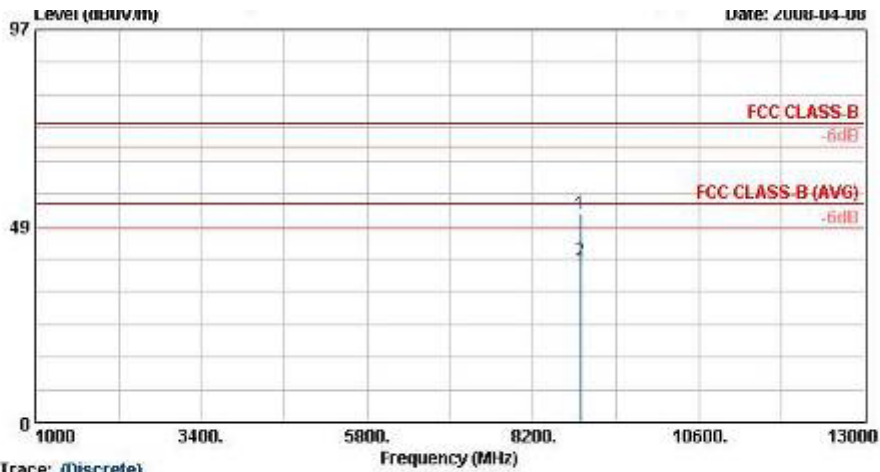

Trace: (Discrete)  
 Site: 03CH06-RV  
 Condition: FCC CLASS-B 3a RF-ANT(8-18)-060018 VERTICAL  
 EUT: MC5574 EUI PCC submit with 1D 2D Scanner  
 Scanner and w/ camera w/o camera  
 Power: 120Vac/60Hz  
 Model: FD 840317  
 Mode: GSM850 Tdls + BT Tdls + WLAN Tdls  
 + Adaptor + USB Link + GPS Rx + MPECH  
 + Camera

	Freq	Level	Over	Limit	ReadAntenna	Cable	Preamp	Ant	Table	Remark
	MHz	dBuV/m	dB	dBuV/m	dBuV	dB/m	dB	dB	cm	deg
1	8894.00	51.44	-22.56	74.00	43.96	36.34	7.68	36.54	100	0 Peak
2	8894.00	40.04	-13.96	54.00	32.56	36.34	7.68	36.54	100	163 Average

**6.4.5 Test Mode: Mode 5 – Sample D**

- Test Distance: 3m
- Temperature: 21~26°C
- Relative Humidity: 51~58%
- Emission level (dBuV/m) = 20 log Emission level (uV/m)
- Test Engineer: Sun
- Corrected Reading: Probe Factor + Cable Loss + Read Level - Preamp Factor = Level

The test that passed at the minimum margin was marked by a frame in the following data

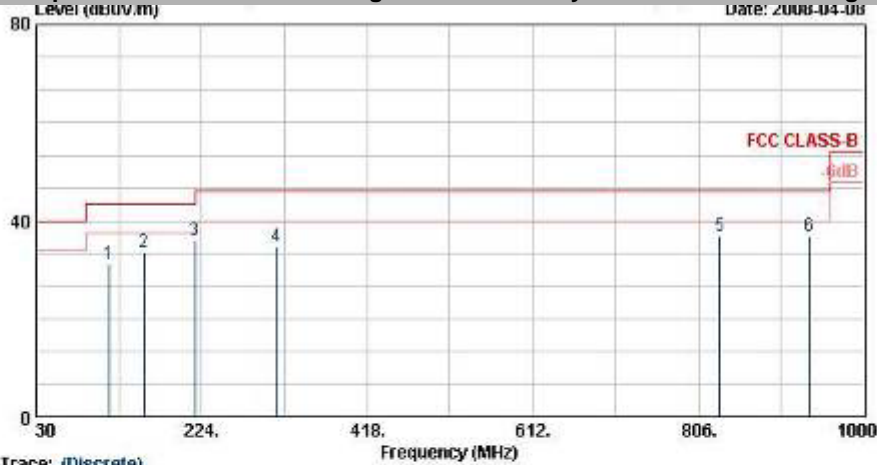

Site  
Condition  
EUT  
Power  
Model  
Mode

Trace: (Discrete)  
00CR06-RY  
FCC CLASS-B 3m LP-ANT(951121) HORIZONTAL  
MC5574 EYI FCC submit with 10 20 Scanner  
Scanner and w/ camera w/o camera  
120Vac/60Hz  
FD 640317  
PCSI900 Table + BT Table + WLAN Table  
+ Adaptor + USB Link + GPS Rx + MP3Cd  
+ Scanner

	Freq	Level	Over	Limit	Read	Antenna	Cable	Preamp	Ant	Table	Remark
	MHz	dBuV/m	dB	dBuV/m	dBuV	dB/m	dB	dB	cm	deg	
1	114.78	31.16	-12.34	43.50	52.08	12.13	0.50	33.55	---	---	Peak
2	156.08	33.68	-9.81	43.50	55.37	10.24	0.60	33.52	---	---	Peak
3	218.03	35.94	-10.08	46.00	58.50	10.27	0.66	33.50	---	---	Peak
4	311.90	34.65	-11.35	46.00	53.63	13.53	0.80	33.30	---	---	Peak
5	831.30	36.93	-9.07	46.00	48.33	20.04	1.20	32.63	---	---	Peak
6	938.30	38.98	-9.02	46.00	47.53	20.79	1.20	32.54	100	288	Peak

Remark: The spurious emission above 1 GHz is too low to be taken.

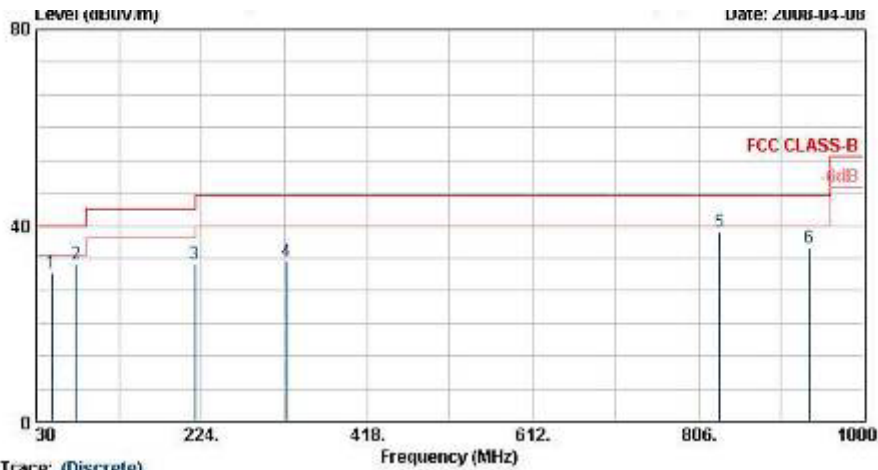

Site  
Condition  
EUT  
Power  
Model  
Mode

Trace: (Discrete)  
03CH06-WY  
FCC CLASS-B 3m LF-ANT(851121) VERTICAL  
#C5574 EYI FCC submit with 10 2D Scanner  
Scanner and w/ camera w/o camera  
120Vac/60Hz  
FD 840317  
PC51800 Idle + BT Idle + WLAN Idle  
+ Adaptor + USB Link + GPS Rx + #P8Gd  
+ Scanner

	Freq	Level	Over	Limit	ReadAntenna	Cable	Preamp	Ant	Table	Remark
	MHz	dBuV/m	Limit	Line	Level	Loss	Loss	Pos	Pos	
			dB	dBuV/m	dBuV	dB	dB	cm	deg	
1	48.09	30.38	-9.62	40.00	54.15	9.08	0.30	33.14	---	Peak
2	76.44	32.00	-8.00	40.00	57.77	7.28	0.43	33.49	---	Peak
3	216.03	32.16	-13.84	46.00	54.73	10.27	0.66	33.50	---	Peak
4	323.80	32.78	-13.22	46.00	51.42	13.83	0.80	33.27	---	Peak
5	831.30	38.78	-7.21	46.00	50.19	20.04	1.20	32.63	100	153 Peak
6	936.30	35.33	-10.67	46.00	45.88	20.79	1.20	32.54	---	Peak

Remark: The spurious emission above 1 GHz is too low to be taken.



## **6.5 Photographs of Radiated Emission Test Configuration**

Please refer to Appendix B

## 7. List of Measuring Equipment

Instrument	Manufacturer	Model No.	Serial No.	Characteristics	Calibration Date	Due Date	Remark
EMC Receiver	R&S	ESCS 30	100132	9kHz – 2.75GHz	Jul. 14, 2007	Jul. 13, 2008	Conduction (CO01-HY)
LISN	MessTec	NNB-2/16Z	2001/004	9kHz – 30MHz	Mar. 24, 2008	Mar. 23, 2009	Conduction (CO01-HY)
LISN (Support Unit)	MessTec	NNB-2/16Z	2001/009	9kHz – 30MHz	Mar. 13, 2008	Mar. 12, 2009	Conduction (CO01-HY)
EMI Filter	LINDGREN	LRE-2060	1004	< 450Hz	N/A	N/A	Conduction (CO01-HY)
EMI Filter	LINDGREN	N6006	201052	0 – 60Hz	N/A	N/A	Conduction (CO01-HY)
RF Cable-CON	Suhner Switzerland	RG223/U	CB029	9kHz – 30MHz	Dec. 03, 2007	Dec. 02, 2008	Conduction (CO01-HY)
Isolation Transformer	Erika Fiedler OHG	D-65396 Walluf	58	45MHz-2.15GHz	N/A	N/A	Conduction (CO01-HY)
Impedance Stabilization	SCHAFFNER	ST08	22589	150kHz – 230MHz	Mar. 03, 2008	Feb. 14, 2009	Conduction (CO01-HY)
Impedance Stabilization	SCHAFFNER	T400	21653	150kHz – 230MHz	May. 09, 2007	May 08, 2008	Conduction (CO01-HY)
Impedance Stabilization	SCHAFFNER	T800	23342	150kHz – 230MHz	Mar. 03, 2008	Mar. 04, 2009	Conduction (CO01-HY)
Spectrum Analyzer	Agilent	E4408B	MY44211028	9KHz-26.5GHz	Oct. 17, 2007	Oct. 16, 2008	Radiation (03CH06-HY)
EMI Test Receiver	R&S	ESCS30	100356	9KHz-2.75GHz	Jul. 26, 2007	Jul. 25, 2008	Radiation (03CH06-HY)
Bilog Antenna	SCHAFFNER	CBL6112B	2885	30MHz -2GHz	Dec. 01, 2007	Nov. 30, 2008	Radiation (03CH06-HY)
Double Ridge Horn Antenna	Com-Power	AH118	071025	1G~18G	Jun. 04, 2007	Jun. 03, 2008	Radiation (03CH06-HY)
SHF-EHF Horn	SCHWARZBECK	BBHA 9170	9170-251	14G - 40G	Oct. 17, 2007	Oct. 16, 2008	Radiation (03CH06-HY)
Pre Amplifier	Agilent	8449B	3008A01917	1G - 26.5G	Nov. 22, 2007	Nov. 21, 2008	Radiation (03CH06-HY)
Pre Amplifier	EMEC	PA303	PA303-SMA-059	100K~3GHz	Nov. 26, 2007	Nov. 25, 2008	Radiation (03CH06-HY)
Base Station Simulator	R & S	CMU200	103937	Third-Band	Oct. 19, 2007	Oct. 18, 2008	Radiation (03CH06-HY)

## 8. Uncertainty of Evaluation

### Uncertainty of Conducted Emission Measurement (150 KHz ~ 30MHz)

Contribution	Uncertainty of $x_i$		$u(x_i)$
	dB	Probability Distribution	
Receiver reading	0.10	Normal(k=2)	0.05
Cable loss	0.10	Normal(k=2)	0.05
AMN insertion loss	2.50	Rectangular	0.63
Receiver Spec	1.50	Rectangular	0.43
Site imperfection	1.39	Rectangular	0.80
Mismatch	+0.34/-0.35	U-shape	0.24
<b>Combined standard uncertainty Uc(y)</b>	<b>1.13</b>		
<b>Measuring uncertainty for a level of confidence of 95% U=2Uc(y)</b>	<b>2.26</b>		

### Uncertainty of Radiated Emission Measurement (30 MHz ~ 1000 MHz)

Contribution	Uncertainty of $x_i$		$u(x_i)$
	dB	Probability Distribution	
Receiver reading	0.41	Normal(k=2)	0.21
Antenna factor calibration	0.83	Normal(k=2)	0.42
Cable loss calibration	0.25	Normal(k=2)	0.13
Pre Amplifier Gain calibration	0.27	Normal(k=2)	0.14
RCV/SPA specification	2.50	Rectangular	0.72
Antenna Factor Interpolation for Frequency	1.00	Rectangular	0.29
Site imperfection	1.43	Rectangular	0.83
Mismatch	+0.39/-0.41	U-shaped	0.28
<b>Combined standard uncertainty Uc(y)</b>	<b>1.27</b>		
<b>Measuring uncertainty for a level of confidence of 95% U=2Uc(y)</b>	<b>2.54</b>		

**Uncertainty of Radiated Emission Measurement (1GHz ~ 40GHz)**

Contribution	Uncertainty of $x_i$		$u(x_i)$	$C_i$	$C_i * u(x_i)$
	dB	Probability Distribution			
Receiver reading	±0.10	Normal(k=1)	0.10	1	0.10
Antenna factor calibration	±1.70	Normal(k=2)	0.85	1	0.85
Cable loss calibration	±0.50	Normal(k=2)	0.25	1	0.25
Receiver Correction	±2.00	Rectangular	1.15	1	1.15
Antenna Factor Directional	±1.50	Rectangular	0.87	1	0.87
Site imperfection	±2.80	Triangular	1.14	1	1.14
Mismatch Receiver VSWR $\Gamma_1 = 0.197$ Antenna VSWR $\Gamma_2 = 0.194$ Uncertainty = $20 \log(1 - \Gamma_1 * \Gamma_2 * \Gamma_3)$	+0.34/-0.35	U-shaped	0.244	1	0.244
<b>Combined standard uncertainty <math>U_c(y)</math></b>	<b>2.36</b>				
<b>Measuring uncertainty for a level of confidence of 95% <math>U = 2U_c(y)</math></b>	<b>4.72</b>				



## 9. Certification of NVLAP Accreditation

United States Department of Commerce  
National Institute of Standards and Technology

**NVLAP<sup>®</sup>**

---

**Certificate of Accreditation to ISO/IEC 17025:2005**

---

NVLAP LAB CODE: 200079-0

**Sporton International, Inc. Hwa Ya EMC Laboratory**  
Tao Yuan Hsien 333  
TAIWAN

*is accredited by the National Voluntary Laboratory Accreditation Program for specific services,  
listed on the Scope of Accreditation, for:*

**ELECTROMAGNETIC COMPATIBILITY AND TELECOMMUNICATIONS**

*This laboratory is accredited in accordance with the recognized International Standard ISO/IEC 17025:2005.  
This accreditation demonstrates technical competence for a defined scope and the operation of a laboratory quality  
management system (refer to joint ISO-ILAC-IAF Communique dated 18 June 2005).*

2008-01-01 through 2008-12-31  
*Effective dates*



*Dolly S. Bruce*  
For the National Institute of Standards and Technology

NVLAP 01C (REV. 2006-08-13)