



FCC Test Report

According to

47 CFR Part 15 Subpart C

Equipment : EDA (Enterprise Digital Assistant)

Trade Name : Symbol

Model No. : MC5574

FCC ID : H9PMC5574

Filing Type : Certification

Applicant : Symbol Technologies Inc

One Symbol Plaza Holtsville, NY 11733-1300 United States

- The test result refers exclusively to the test presented test model / sample.
- Without written approval of SPORTON International Inc., the test report shall not be reproduced except in full.
- **Certificate or Test Report must not be used by the applicant to claim the product in this test report endorsement by NVLAP or any agency of U.S. government.**
- The data shown in this test report were carried out on Apr. 11, 2008 at **Sporton International Inc. LAB.**
- Report No.: FR840317B, Report Version: Rev.01

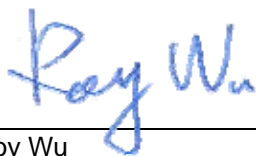

Roy Wu
Manager

SPORTON International Inc.

No. 52, Hwa Ya 1st Rd., Hwa Ya Technology Park, Kwei-Shan Hsiang, Tao Yuan Hsien, Taiwan, R.O.C.

Table of Contents

History of this test report	ii
1. General Description of Equipment under Test	1
1.1 Applicant.....	1
1.2 Manufacturer	1
1.3 Basic Description of Equipment under Test.....	1
1.4 Feature of Equipment under Test.....	2
2. Test Configuration of Equipment under Test	3
2.1 Test Manner	3
2.2 Test Mode	4
2.3 Ancillary Equipment List	4
2.4 Connection Diagram of Test System	5
3. RF Utility	6
4. General Information of Test	7
4.1 Test Voltage	7
4.2 Standard for Methods of Measurement	7
4.3 Test Compliance.....	7
4.4 Frequency Range.....	7
4.5 Test Distance.....	7
5. Test Data and Test Result	8
5.1 List of Measurements and Examinations.....	8
5.2 6dB Bandwidth Measurement	9
5.3 Power Spectral Density Measurement	17
5.4 Band Edges Measurement	25
5.5 Peak Output Power Measurement.....	36
5.6 Conducted Emission.....	44
5.7 Radiated Emission Measurement.....	55
5.8 Antenna Requirements.....	85
6. List of Measuring Equipments	86
7. Uncertainty Evaluation	87
 Appendix A. External Photographs of EUT	
Appendix B. Internal Photographs of EUT	
Appendix C. Setup Photographs	

1. General Description of Equipment under Test

1.1 Applicant

Symbol Technologies Inc
 One Symbol Plaza Holtsville, NY 11733-1300 United States

1.2 Manufacturer

ASKEY COMPUYER CORP
 10F, No. 119, CHIENKANG RD., CHUNG-HO, TAIPEI, TAIWAN, 235, R.O.C

1.3 Basic Description of Equipment under Test

Equipment	EDA (Enterprise Digital Assistant)	
Trade Name	Symbol	
Model Name	MC5574	
FCC ID	H9PMC5574	
Sample A	1D scanner without camera	
Sample B	2D scanner without camera	
Sample C	1D scanner with camera	
Sample D	2D scanner with camera	
AC Adapter	Brand Name	DELTA
	Model Name	ADP-16GB
	Power Rating	I/P: 100-240Vac, 50-60Hz, 0.4A; O/P: 5.4Vdc, 3A
	AC Power Cord Type	AC: 1.8 meter non-shielded cable with ferrite core DC: 1.8 meter non-shielded cable without ferrite core
Battery	Brand Name	SYMBOL
	Part Number	82-107172-01 Rev A
	Power Rating	3.7Vdc, 2400mAh
	Type	Li-ion
Communication USB charge cable	Brand Name	SYMBOL
	Part Number	25-108022-01R Rev. 1
	Signal Line Type	1.5 meter shielded cable without ferrite core

Remark: Above EUT's information was declared by manufacturer. Please refer to specifications of manufacturer or User's Manual for more detailed features description.

1.4 Feature of Equipment under Test

Product Feature & Specification	
DUT Type :	EDA (Enterprise Digital Assistant)
Trade Name :	Symbol
Model Name :	MC5574
FCC ID :	H9PMC5574
Tx Frequency :	GSM850 : 824 MHz ~ 849 MHz GSM1900 : 1850 MHz ~1910 MHz Bluetooth : 2400 MHz ~ 2483.5 MHz WLAN : 2400 MHz ~ 2483.5 MHz
Rx Frequency :	GSM850 : 869 MHz ~ 894 MHz GSM1900 : 1930 MHz ~ 1990 MHz Bluetooth : 2400 MHz ~ 2483.5 MHz WLAN : 2400 MHz ~ 2483.5 MHz
Maximum Output Power to Antenna :	GSM850 : 32.43 dBm (GSM) / 32.41 dBm (GPRS8) / 30.62 dBm (GPRS10) / 26.87 dBm (GPRS12) / 25.94 dBm (EGPRS8) / 23.83 dBm (EGPRS10) / 19.67 dBm (EGPRS12) / GSM1900 : 29.50 dBm (GSM) / 29.39 dBm (GPRS8) / 27.55 dBm (GPRS10) / 23.79 dBm (GPRS12) / 25.06 dBm (EGPRS8) / 23.26 dBm (EGPRS10) / 19.22 dBm (EGPRS12) / Bluetooth : 4.76 dBm WLAN : 14.57 dBm (802.11b) / 15.52 dBm (802.11g)
Type of Antenna Connector :	N/A
Antenna Type :	GSM : PIFA Antenna Bluetooth : Chip antenna WLAN : PIFA Antenna
Antenna Gain :	Bluetooth : -0.94 dBi WLAN : 1.22 dBi
GPRS / EGPRS Multislot class :	12
Type of Modulation :	GSM / GPRS : GMSK EDGE : 8PSK Bluetooth : GFSK WLAN : DSSS / OFDM
DUT Stage :	Identical Prototype

2. Test Configuration of Equipment under Test

2.1 Test Manner

- a. The EUT has been associated with peripherals pursuant to ANSI C63.4-2003 and configuration operated in a manner tended to maximize its emission characteristics in a typical application.
- b. Power Table as below:

802.11b

Channel	Frequency (MHz)	Data Rate (dBm)			
		1 Mbps	2 Mbps	5.5 Mbps	11 Mbps
CH 01	2412 MHz	14.22	14.57	14.54	14.49
CH 06	2437 MHz	14.21	14.33	14.44	14.38
CH 11	2462 MHz	13.52	13.56	14.16	14.13

802.11g

Channel	Frequency (MHz)	Data Rate (dBm)							
		6 Mbps	9 Mbps	12 Mbps	18 Mbps	24 Mbps	36 Mbps	48 Mbps	54 Mbps
CH 01	2412 MHz	11.96	11.67	11.61	11.71	11.82	11.93	11.97	11.98
CH 06	2437 MHz	15.52	15.18	14.95	15.16	14.37	14.46	13.57	13.60
CH 11	2462 MHz	11.81	11.66	11.78	11.78	11.77	11.86	11.81	11.70

The 802.11b/g data rate were set in 2Mbps and 6Mbps, due to the highest RF output power.

- c. The EUT is programmed to transmit signal continuously for all testings.
- d. Frequency range investigated: conduction 150 kHz to 30 MHz, radiation 30 MHz to 25000MHz.

2.2 Test Mode

Pre-scanned tests were conducted to determine the final configuration from all possible combinations. The test modes shown in the following tables were tested as the worst cases and recorded in this report.

Application	Test Modes	
Radiated Emission	802.11b	802.11g
	Mode 1: CH01_2412 MHz	Mode 4: CH01_2412 MHz
	Mode 2: CH06_2437 MHz	Mode 5: CH06_2437 MHz
	Mode 3: CH11_2462 MHz	Mode 6: CH11_2462 MHz
Conducted Emission	Mode 7: CH01_2412 MHz + BT CH39_2480 MHz	
	Mode 1 : GSM850 Idle + BT Idle + WLAN Idle + Adapter + USB Link + GPS Rx + MPEG 4 + Camera for Sample D	
	Mode 2 : GSM1900 Idle + BT Idle + WLAN Idle + Adapter + USB Link + GPS Rx + MPEG 4 + Scanner for Sample D	
	Mode 3 : EDGE Idle + BT Idle + WLAN Idle + Adapter + USB Link + GPS Rx + MPEG 4 + Scanner for Sample C	
	Mode 4 : GSM850 Idle + BT Idle + WLAN Idle + Adapter + USB Link + GPS Rx + MPEG 4 + Scanner for Sample B	
Mode 5 : GSM850 Idle + BT Idle + WLAN Idle + Adapter + USB Link + GPS Rx + MPEG 4 + Scanner for Sample A		

2.3 Ancillary Equipment List

Item	Equipment	Trade Name	Model Name	FCC ID	Data Cable	Power Cord
1.	Base Station	R&S	CMU 200	N/A	N/A	Unshielded, 1.8 m
2.	GPS Station	T&E	GS-50	N/A	N/A	Unshielded, 1.8 m
3.	WLAN AP	SMC	SMC-100	HEDWG4005ACC	N/A	Unshielded, 1.8 m
4.	Notebook	DELL	D400	E2K24GBRL	N/A	AC I/P: Unshielded, 1.2 m DC O/P: Shielded, 1.8 m
5.	Bluetooth Earphone	Engotech	ET-BH111	PQY471087	N/A	N/A
6.	RS-232 Mouse	State	MS-303	DoC	Unshielded, 1.2 m	N/A
7.	i-pod	Apple	A1199	DoC	Unshielded, 1.2 m	N/A

2.4 Connection Diagram of Test System

<Conducted Emission>

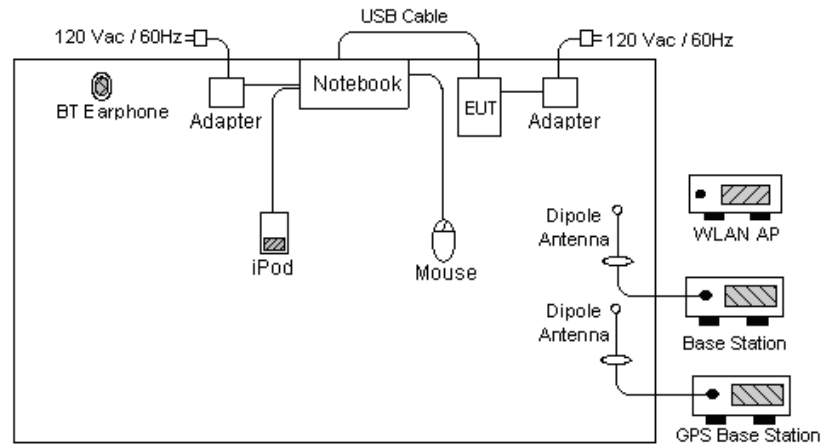

<Radiated Emission>

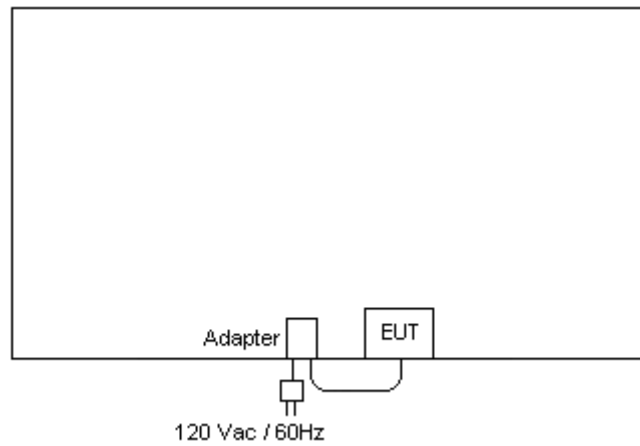

3. RF Utility

The programmed RF Utility "CEcTxRx" is installed in EUT to provide channel selection, power level, data rate and the application type. RF Utility can send transmitting signal for all testings.

4. General Information of Test

Test Site Location : No. 52, Hwa Ya 1st Rd., Hwa Ya Technology Park,
Kwei-Shan Hsiang, Tao Yuan Hsien, Taiwan, R.O.C.
TEL : 886-3-327-3456
FAX : 886-3-328-4978

Test Site No : CO01-HY, 03CH06-HY

4.1 Test Voltage

AC 120V / 60Hz

4.2 Standard for Methods of Measurement

FCC 47 CFR Part 15, Subpart C 15.247
ANSI C63.4-2003
Measurement of Digital Transmission Systems Operating under Section 15.247 March 23, 2005

4.3 Test Compliance

47 CFR Part 15 Subpart C

4.4 Frequency Range

- a. Conduction: from 150 kHz to 30 MHz
- b. Radiation: from 30 MHz to 25000 MHz

4.5 Test Distance

The test distance of radiated emission from antenna to EUT is 3 m.

5. Test Data and Test Result

5.1 List of Measurements and Examinations

The Emission Mode: Wireless LAN

FCC Rule	Description of Test	Result
15.207	Conducted Emission	Pass
15.247(a)(2)	6dB Bandwidth	Pass
15.247(b)	Maximum Peak Output Power	Pass
15.209(a) 15.247(d)	Radiated Emission	Pass
15.247(d)	100 KHz Bandwidth of Frequency Band Edges	Pass
15.247(e)	Power Spectral Density	Pass
15.203 15.247(b)(4)	Antenna Requirement	Pass

5.2 6dB Bandwidth Measurement

5.2.1 Measuring Instruments

As described in chapter 6 of this test report.

5.2.2 Test Procedure

1. The transmitter output was connected to the spectrum analyzer directly.
2. Set RBW of spectrum analyzer to 100kHz and VBW to 100kHz.
3. The 6 dB bandwidth is defined as the frequency range where the power is higher than the peak power minus 6dB.

5.2.3 Test Setup Layout

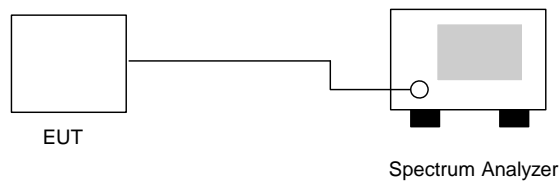

5.2.4 Test Result

- Application Type : WLAN 802.11b/g
- Temperature : 21~26
- Relative Humidity : 50~58%
- Test Enginner : Sun

▪ **802.11b**

Channel	Frequency (MHz)	6dB Emission bandwidth (MHz)	Limits (MHz)	Plot Ref. No.
01	2412	12.32	> 0.5MHz	Plot 1
06	2437	12.32	> 0.5MHz	Plot 2
11	2462	12.32	> 0.5MHz	Plot 3

▪ **802.11g**

Channel	Frequency (MHz)	6dB Emission bandwidth (MHz)	Limits (MHz)	Plot Ref. No.
01	2412	16.32	> 0.5MHz	Plot 4
06	2437	16.32	> 0.5MHz	Plot 5
11	2462	16.36	> 0.5MHz	Plot 6

5.2.5 6dB Bandwidth

Plot 1

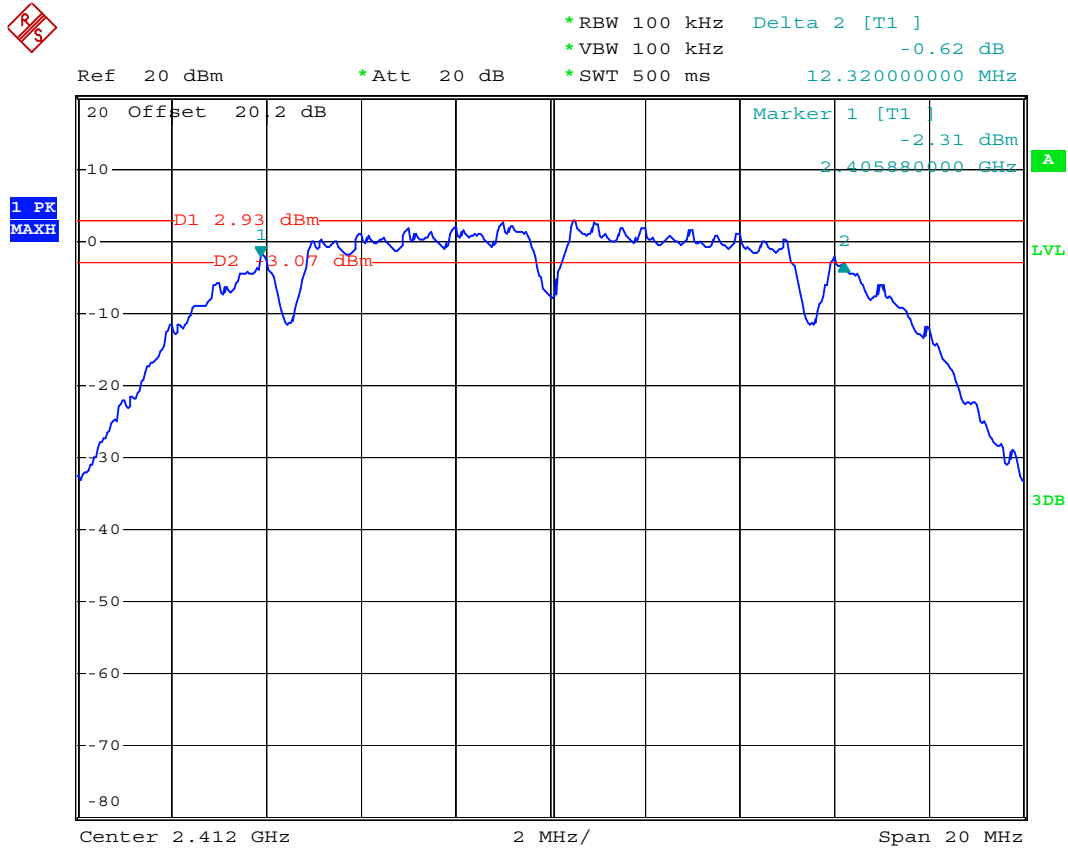

Date: 9.APR.2008 04:18:01

Plot 2

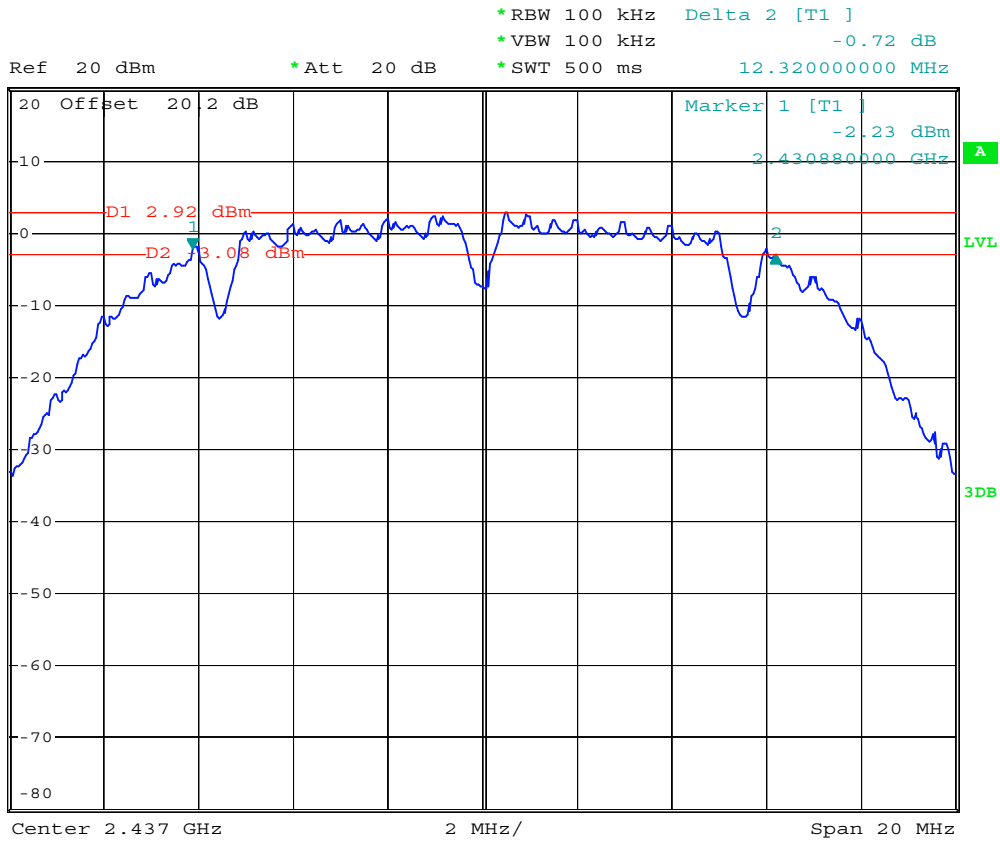

Date: 9.APR.2008 04:20:42

Plot 3

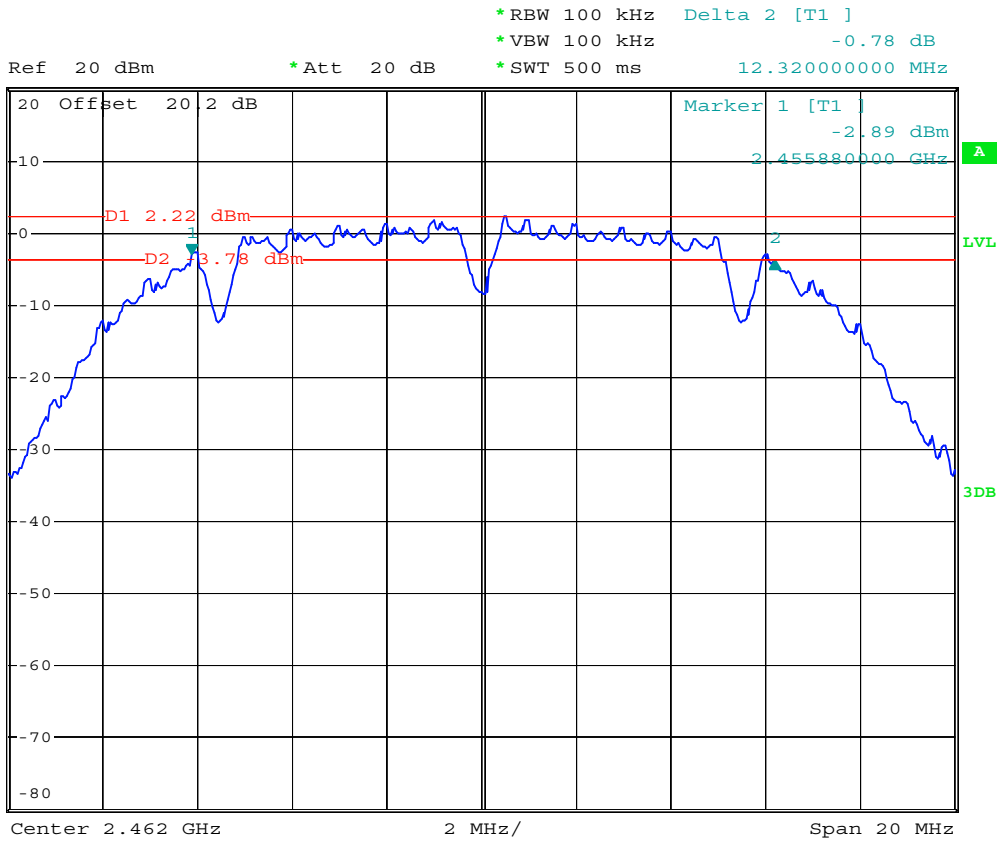

Date: 9.APR.2008 04:22:27

Plot 4

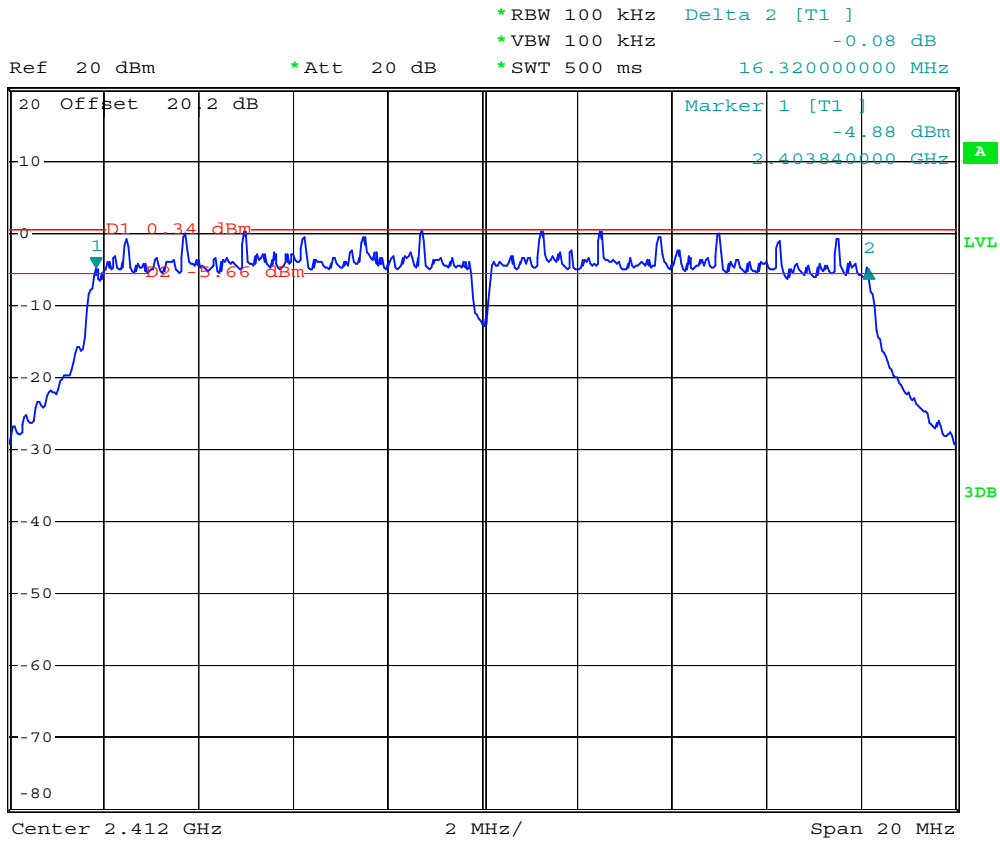

Date: 9.APR.2008 05:30:11

Plot 5

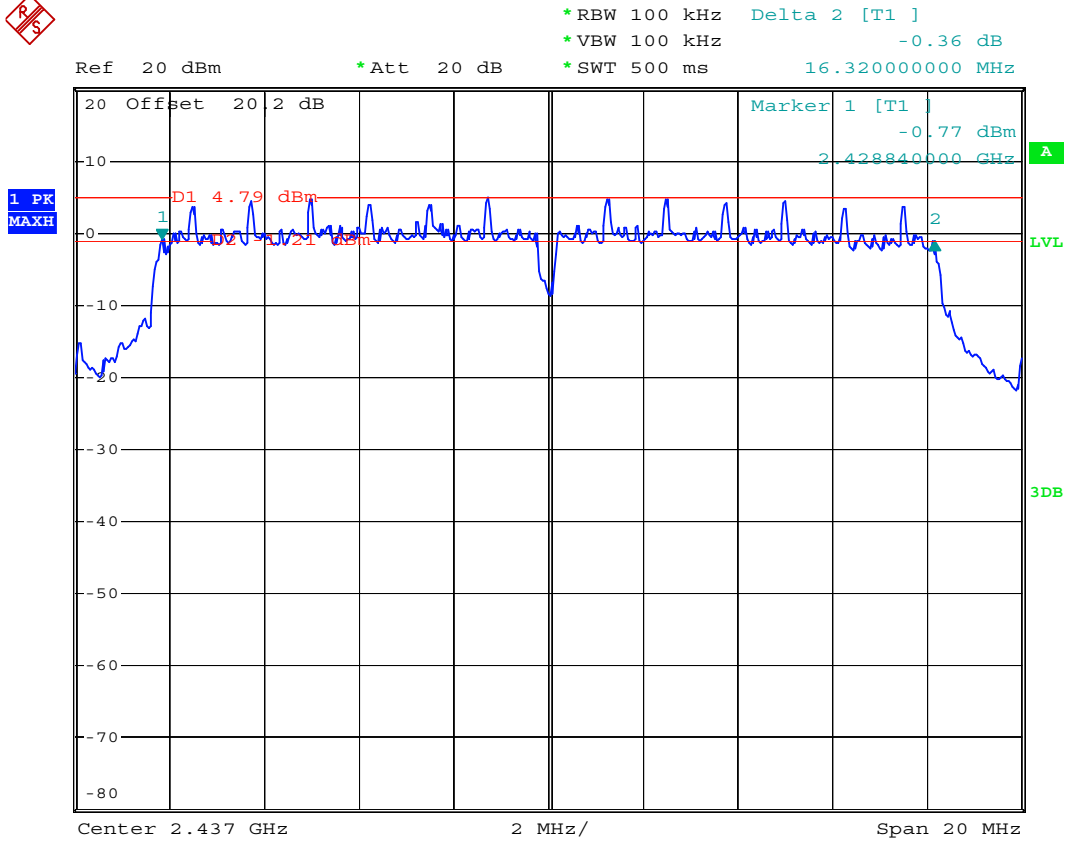

Date: 9.APR.2008 05:31:22

Plot 6

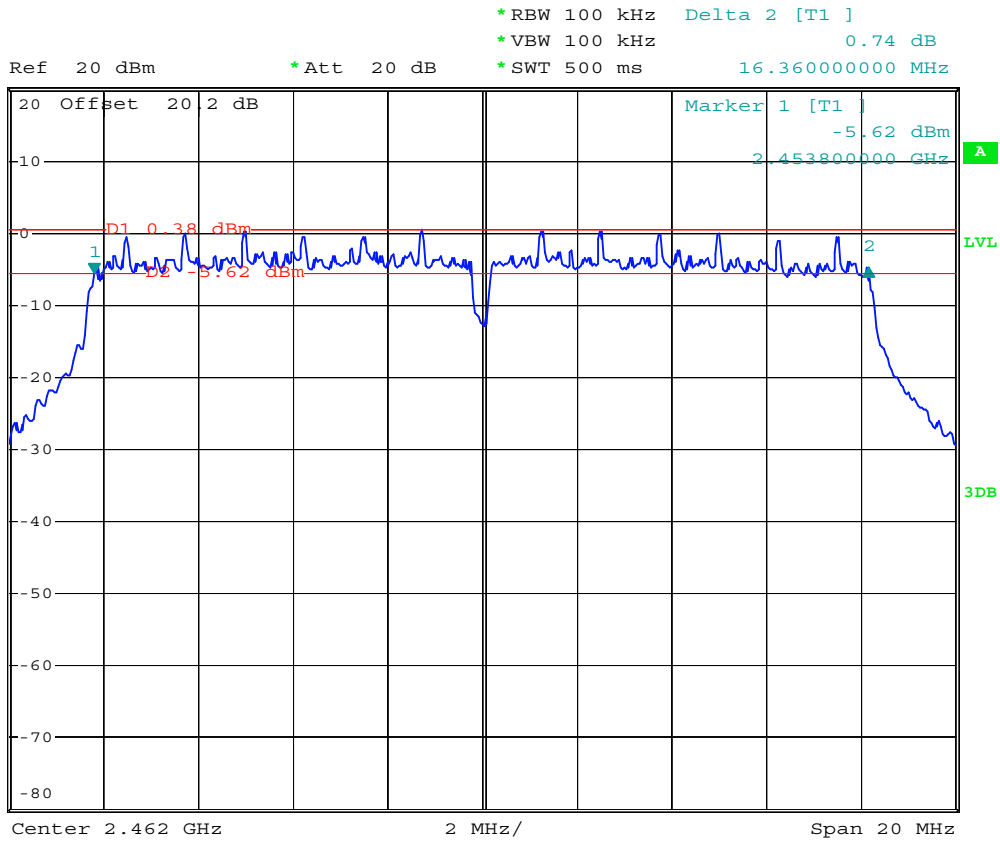

Date: 9.APR.2008 05:32:38

5.3 Power Spectral Density Measurement

5.3.1 Measuring Instruments

As described in chapter 6 of this test report.

5.3.2 Test Procedure

1. The transmitter output was connected to spectrum analyzer directly.
2. The spectrum analyzer's resolution bandwidth was set at 3kHz RBW and 30kHz VBW as that of the fundamental frequency. Set the sweep time=span/3kHz.
3. The power spectral density was measured and recorded.
4. The sweep time is allowed to be longer than span/3kHz for a full response of the mixer in the spectrum analyzer.

5.3.3 Test Setup Layout

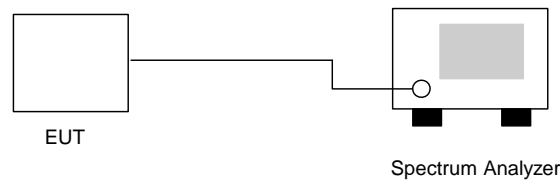

5.3.4 Test Result

- Application Type : 802.11b/g
- Temperature : 21~26
- Relative Humidity : 50~58%
- Test Enginner : Sun

802.11b

Channel	Frequency (MHz)	Power Spectral Density (dBm)	Limits (dBm)	Plot Ref. No.
01	2412	-10.53	8	Plot 1
06	2437	-10.53	8	Plot 2
11	2462	-11.27	8	Plot 3

802.11g

Channel	Frequency (MHz)	Power Spectral Density (dBm)	Limits (dBm)	Plot Ref. No.
01	2412	-16.86	8	Plot 4
06	2437	-12.89	8	Plot 5
11	2462	-16.88	8	Plot 6

5.3.5 Power Spectral Density

Plot 1

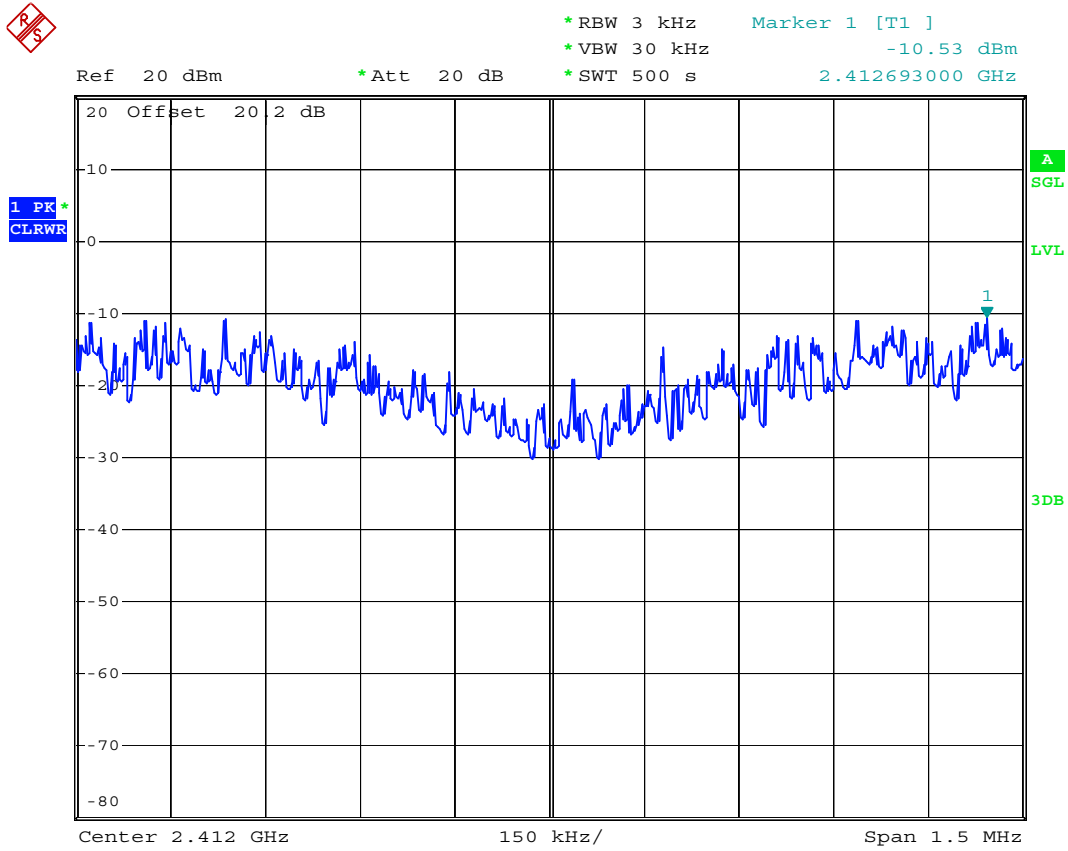

Date: 9.APR.2008 04:40:14

Plot 2

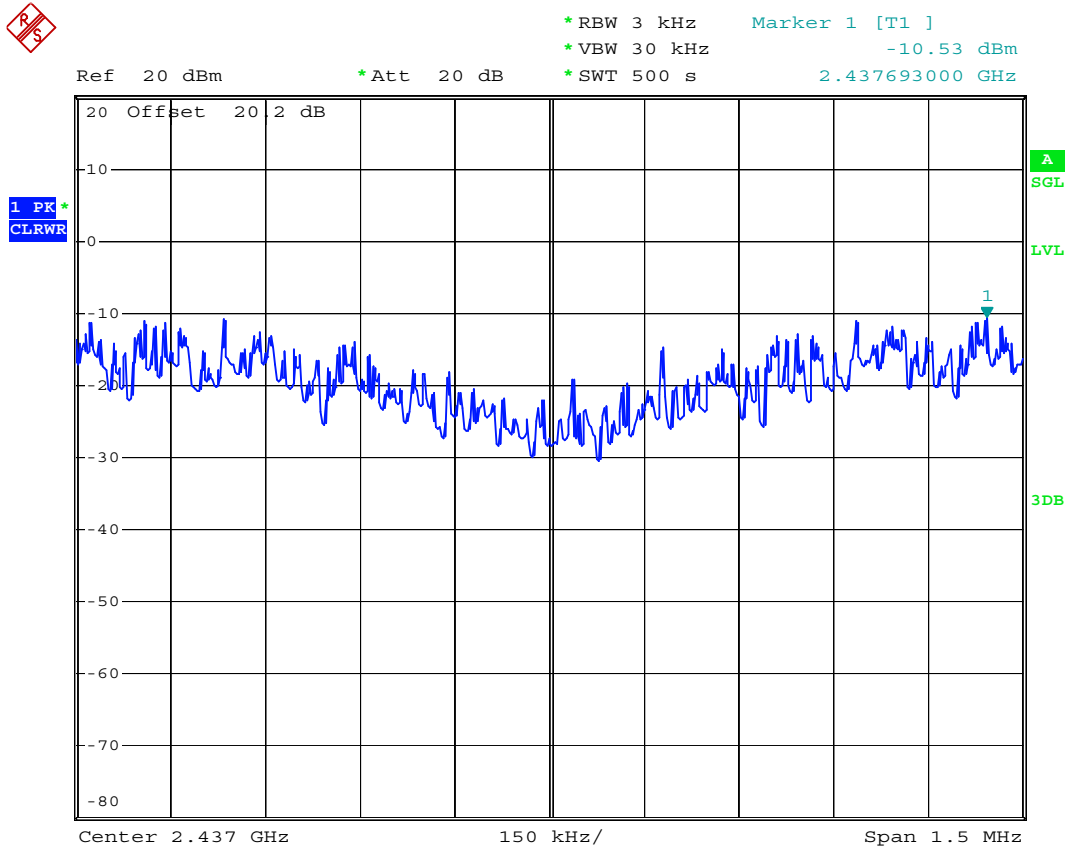

Date: 9.APR.2008 04:49:16

Plot 3

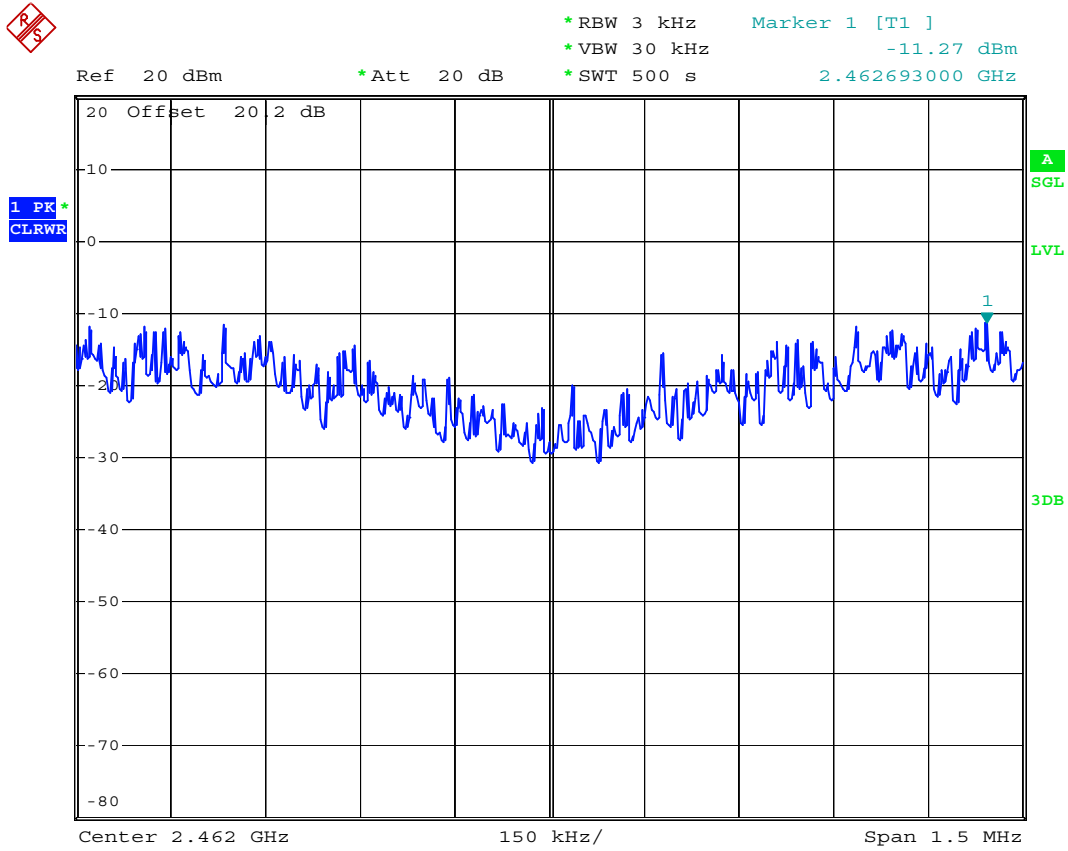

Date: 9.APR.2008 05:00:04

Plot 4

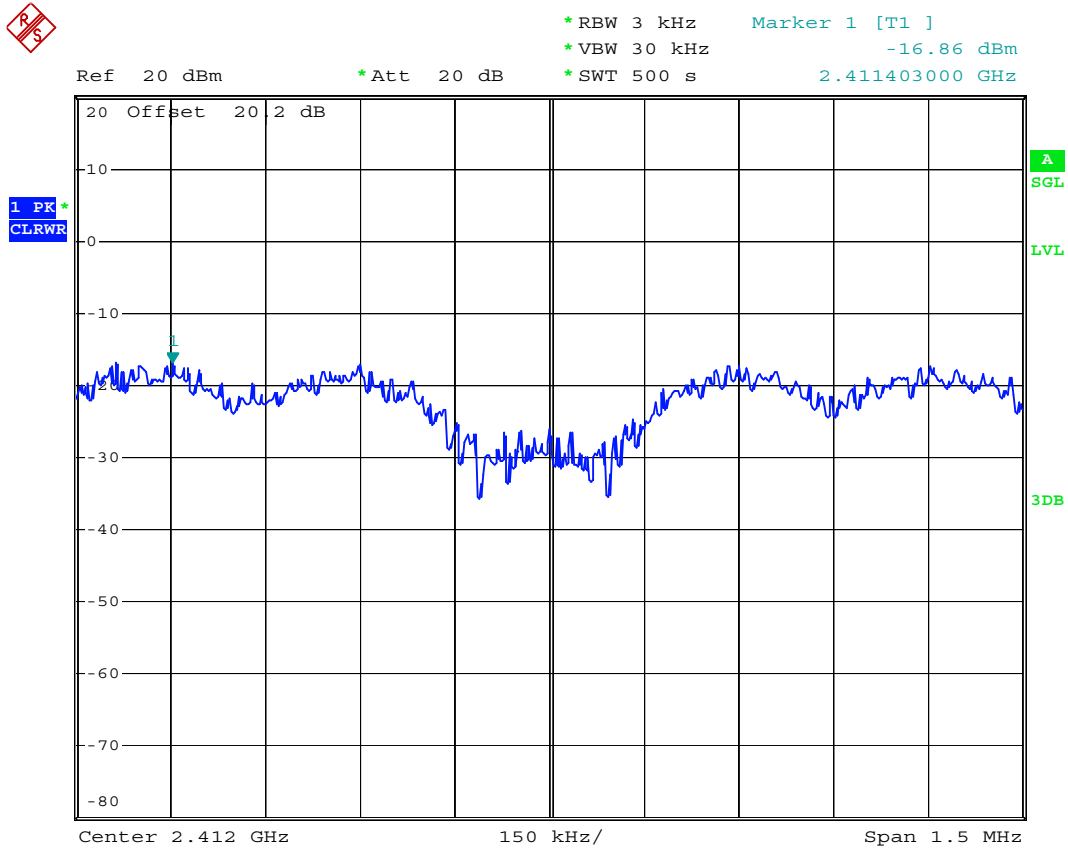

Date: 9.APR.2008 05:28:37

Plot 5

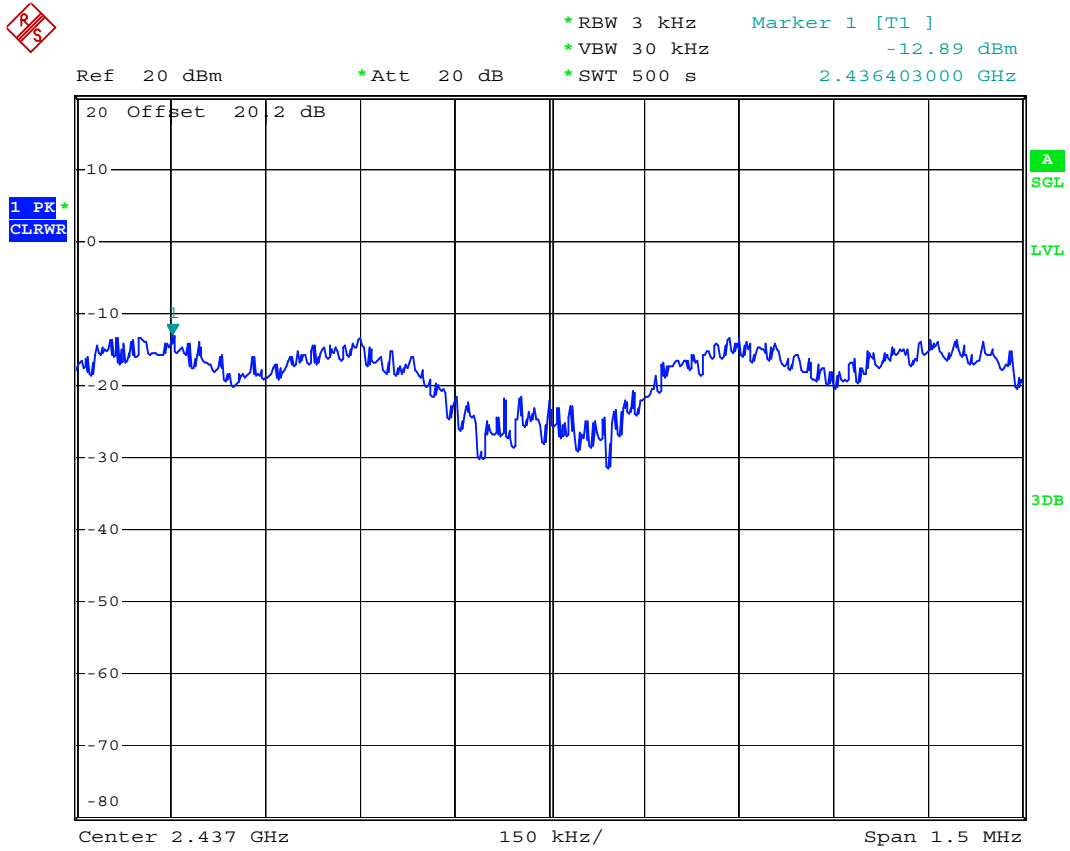

Date: 9.APR.2008 05:18:49

Plot 6

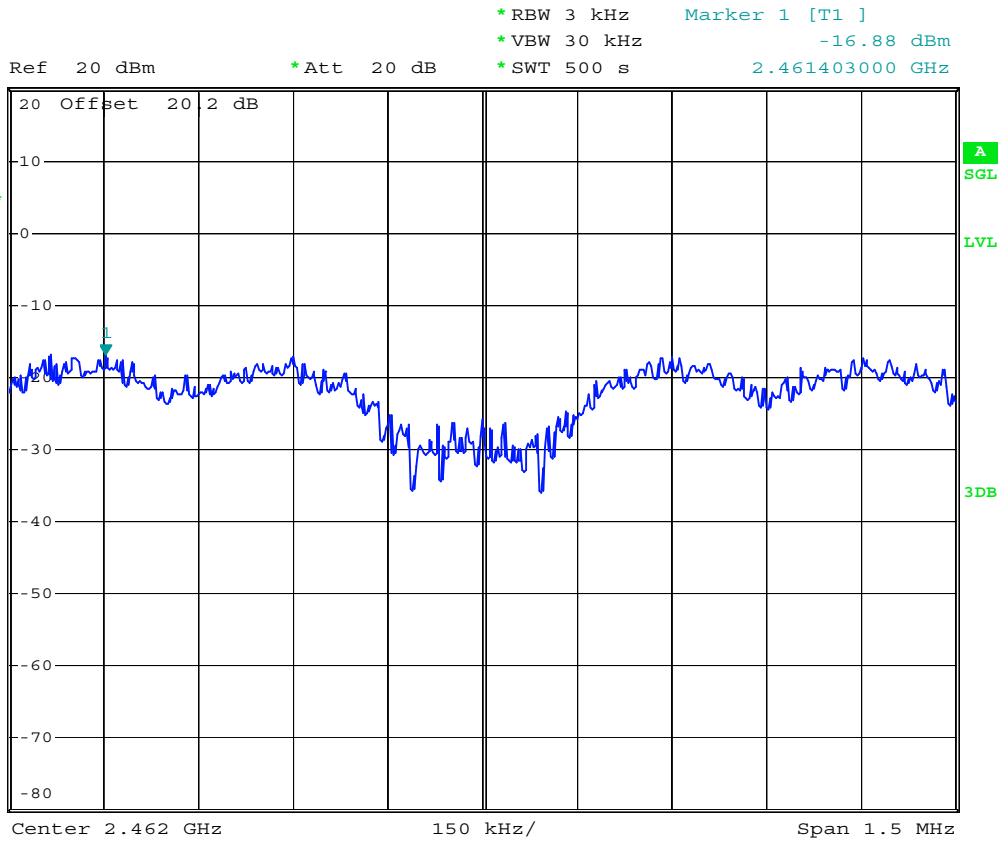

Date: 9.APR.2008 05:09:29

5.4 Band Edges Measurement

5.4.1 Measuring Instruments

As described in chapter 6 of this test report.

5.4.2 Test Procedure

1. The transmitter output was connected to the spectrum analyzer via a low lose cable.
2. Set both RBW and VBW of spectrum analyzer to 100 KHz with suitable frequency span including 100 KHz bandwidth from band edge.
3. The band edges was measured and recorded.

5.4.3 Test Result

- Application Type : WLAN 802.11b/g
- Temperature : 21~26
- Relative Humidity : 50~58%
- Test Enginner : Sun

Test Result in WLAN lower band (802.11b/g)	: PASS
Test Result in WLAN higher band (802.11b/g)	: PASS

5.4.4 Note on Band Edge Emission

<Sample A>

>WLAN 802.11b

CH01 (Horizontal)

Frequency (MHz)	Level (dBuV/m)	Over Limit (dB)	Limit Line (dBuV/m)	Read Level (dBuV)	Antenna Factor (dB)	Cable Loss (dB)	Preamp Factor (dB)	Ant Pos (cm)	Table Pos (deg)	Remark
2390.00	46.87	-7.13	54.00	46.77	31.86	3.92	35.68	100	21	Average
2390.00	67.68	-6.32	74.00	67.58	31.86	3.92	35.68	100	0	Peak

CH01 (Vertical)

Frequency (MHz)	Level (dBuV/m)	Over Limit (dB)	Limit Line (dBuV/m)	Read Level (dBuV)	Antenna Factor (dB)	Cable Loss (dB)	Preamp Factor (dB)	Ant Pos (cm)	Table Pos (deg)	Remark
2390.00	42.34	-11.66	54.00	42.24	31.86	3.92	35.68	100	237	Average
2390.00	61.77	-12.23	74.00	61.67	31.86	3.92	35.68	100	0	Peak

CH11 (Horizontal)

Frequency (MHz)	Level (dBuV/m)	Over Limit (dB)	Limit Line (dBuV/m)	Read Level (dBuV)	Antenna Factor (dB)	Cable Loss (dB)	Preamp Factor (dB)	Ant Pos (cm)	Table Pos (deg)	Remark
2483.50	41.90	-12.10	54.00	41.57	31.98	4.05	35.70	118	23	Average
2483.50	67.54	-6.46	74.00	67.21	31.98	4.05	35.70	100	0	Peak

CH11 (Vertical)

Frequency (MHz)	Level (dBuV/m)	Over Limit (dB)	Limit Line (dBuV/m)	Read Level (dBuV)	Antenna Factor (dB)	Cable Loss (dB)	Preamp Factor (dB)	Ant Pos (cm)	Table Pos (deg)	Remark
2483.50	39.43	-14.57	54.00	39.10	31.98	4.05	35.70	106	325	Average
2483.50	64.90	-9.10	74.00	64.57	31.98	4.05	35.70	100	0	Peak

>WLAN 802.11g

CH01 (Horizontal)

Frequency (MHz)	Level (dBuV/m)	Over Limit (dB)	Limit Line (dBuV/m)	Read Level (dBuV)	Antenna Factor (dB)	Cable Loss (dB)	Preamp Factor (dB)	Ant Pos (cm)	Table Pos (deg)	Remark
2390.00	49.85	-4.15	54.00	49.75	31.86	3.92	35.68	100	20	Average
2390.00	68.32	-5.68	74.00	68.22	31.86	3.92	35.68	100	0	Peak

CH01 (Vertical)

Frequency (MHz)	Level (dBuV/m)	Over Limit (dB)	Limit Line (dBuV/m)	Read Level (dBuV)	Antenna Factor (dB)	Cable Loss (dB)	Preamp Factor (dB)	Ant Pos (cm)	Table Pos (deg)	Remark
2390.00	45.55	-8.45	54.00	45.45	31.86	3.92	35.68	128	234	Average
2390.00	64.05	-9.95	74.00	63.95	31.86	3.92	35.68	100	0	Peak

CH11 (Horizontal)

Frequency (MHz)	Level (dBuV/m)	Over Limit (dB)	Limit Line (dBuV/m)	Read Level (dBuV)	Antenna Factor (dB)	Cable Loss (dB)	Preamp Factor (dB)	Ant Pos (cm)	Table Pos (deg)	Remark
2483.50	46.52	-7.48	54.00	46.19	31.98	4.05	35.70	118	23	Average
2483.50	66.75	-7.25	74.00	66.42	31.98	4.05	35.70	100	0	Peak

CH11 (Vertical)

Frequency (MHz)	Level (dBuV/m)	Over Limit (dB)	Limit Line (dBuV/m)	Read Level (dBuV)	Antenna Factor (dB)	Cable Loss (dB)	Preamp Factor (dB)	Ant Pos (cm)	Table Pos (deg)	Remark
2483.50	44.67	-9.33	54.00	44.34	31.98	4.05	35.70	105	327	Average
2783.50	64.68	-9.32	74.00	64.35	31.98	4.05	35.70	100	0	Peak

<Sample B>

>WLAN 802.11b

CH01 (Horizontal)

Frequency (MHz)	Level (dBuV/m)	Over Limit (dB)	Limit Line (dBuV/m)	Read Level (dBuV)	Antenna Factor (dB)	Cable Loss (dB)	Preamp Factor (dB)	Ant Pos (cm)	Table Pos (deg)	Remark
2390.00	69.55	4.45	74.00	69.45	31.86	3.92	35.68	100	0	Peak
2390.00	46.56	-7.44	54.00	46.46	31.86	3.92	35.68	100	356	Average

CH01 (Vertical)

Frequency (MHz)	Level (dBuV/m)	Over Limit (dB)	Limit Line (dBuV/m)	Read Level (dBuV)	Antenna Factor (dB)	Cable Loss (dB)	Preamp Factor (dB)	Ant Pos (cm)	Table Pos (deg)	Remark
2390.00	43.08	-10.92	54.00	42.98	31.86	3.92	35.68	130	29	Average
2390.00	66.54	-7.46	74.00	66.44	31.86	3.92	35.68	100	0	Peak

CH11 (Horizontal)

Frequency (MHz)	Level (dBuV/m)	Over Limit (dB)	Limit Line (dBuV/m)	Read Level (dBuV)	Antenna Factor (dB)	Cable Loss (dB)	Preamp Factor (dB)	Ant Pos (cm)	Table Pos (deg)	Remark
2483.50	44.19	-9.81	54.00	43.86	31.98	4.05	35.70	117	13	Average
2483.50	68.96	-5.04	74.00	68.63	31.98	4.05	35.70	100	0	Peak

CH11 (Vertical)

Frequency (MHz)	Level (dBuV/m)	Over Limit (dB)	Limit Line (dBuV/m)	Read Level (dBuV)	Antenna Factor (dB)	Cable Loss (dB)	Preamp Factor (dB)	Ant Pos (cm)	Table Pos (deg)	Remark
2483.50	67.70	-6.30	74.00	67.37	31.98	4.05	35.70	100	0	Peak
2483.50	43.25	-10.75	54.00	42.92	31.98	4.05	35.70	130	77	Average

>WLAN 802.11g

CH01 (Horizontal)

Frequency (MHz)	Level (dBuV/m)	Over Limit (dB)	Limit Line (dBuV/m)	Read Level (dBuV)	Antenna Factor (dB)	Cable Loss (dB)	Preamp Factor (dB)	Ant Pos (cm)	Table Pos (deg)	Remark
2390.00	47.54	-6.46	54.00	47.44	31.86	3.92	35.68	100	20	Average
2390.00	67.57	-6.43	74.00	67.47	31.86	3.92	35.68	100	0	Peak

CH01 (Vertical)

Frequency (MHz)	Level (dBuV/m)	Over Limit (dB)	Limit Line (dBuV/m)	Read Level (dBuV)	Antenna Factor (dB)	Cable Loss (dB)	Preamp Factor (dB)	Ant Pos (cm)	Table Pos (deg)	Remark
2390.00	60.60	-13.40	74.00	60.50	31.86	3.92	35.68	100	0	Peak
2390.00	40.46	-13.54	54.00	40.36	31.86	3.92	35.68	100	124	Average

CH11 (Horizontal)

Frequency (MHz)	Level (dBuV/m)	Over Limit (dB)	Limit Line (dBuV/m)	Read Level (dBuV)	Antenna Factor (dB)	Cable Loss (dB)	Preamp Factor (dB)	Ant Pos (cm)	Table Pos (deg)	Remark
2483.50	40.79	-13.21	54.00	40.45	31.98	4.05	35.69	100	124	Average
2483.50	60.93	-13.07	74.00	60.59	31.98	4.05	35.69	100	0	Peak

CH11 (Vertical)

Frequency (MHz)	Level (dBuV/m)	Over Limit (dB)	Limit Line (dBuV/m)	Read Level (dBuV)	Antenna Factor (dB)	Cable Loss (dB)	Preamp Factor (dB)	Ant Pos (cm)	Table Pos (deg)	Remark
2483.50	67.91	-6.09	74.00	67.57	31.98	4.05	35.69	100	0	Peak
2483.50	47.56	-6.44	54.00	47.22	31.98	4.05	35.69	131	78	Average

<Sample C>

>WLAN 802.11b

CH01 (Horizontal)

Frequency (MHz)	Level (dBuV/m)	Over Limit (dB)	Limit Line (dBuV/m)	Read Level (dBuV)	Antenna Factor (dB)	Cable Loss (dB)	Preamp Factor (dB)	Ant Pos (cm)	Table Pos (deg)	Remark
2390.00	50.98	-3.02	54.00	50.88	31.86	3.92	35.68	100	356	Average
2390.00	69.23	-4.77	74.00	69.13	31.86	3.92	35.68	100	0	Peak

CH01 (Vertical)

Frequency (MHz)	Level (dBuV/m)	Over Limit (dB)	Limit Line (dBuV/m)	Read Level (dBuV)	Antenna Factor (dB)	Cable Loss (dB)	Preamp Factor (dB)	Ant Pos (cm)	Table Pos (deg)	Remark
2390.00	48.62	-5.38	54.00	48.52	31.86	3.92	35.68	100	238	Average
2390.00	64.86	-9.14	74.00	64.76	31.86	3.92	35.68	100	0	Peak

CH11 (Horizontal)

Frequency (MHz)	Level (dBuV/m)	Over Limit (dB)	Limit Line (dBuV/m)	Read Level (dBuV)	Antenna Factor (dB)	Cable Loss (dB)	Preamp Factor (dB)	Ant Pos (cm)	Table Pos (deg)	Remark
2483.50	50.98	-3.02	54.00	50.64	31.98	4.05	35.69	119	24	Average
2483.5	67.61	-6.39	74.00	67.27	31.98	4.05	35.69	100	0	Peak

CH11 (Vertical)

Frequency (MHz)	Level (dBuV/m)	Over Limit (dB)	Limit Line (dBuV/m)	Read Level (dBuV)	Antenna Factor (dB)	Cable Loss (dB)	Preamp Factor (dB)	Ant Pos (cm)	Table Pos (deg)	Remark
2483.50	43.88	-10.12	54.00	43.54	31.98	4.05	35.69	120	233	Average
2483.50	65.66	-8.34	74.00	65.32	31.98	4.05	35.69	100	0	Peak

➤WLAN 802.11g

CH01 (Horizontal)

Frequency (MHz)	Level (dBuV/m)	Over Limit (dB)	Limit Line (dBuV/m)	Read Level (dBuV)	Antenna Factor (dB)	Cable Loss (dB)	Preamp Factor (dB)	Ant Pos (cm)	Table Pos (deg)	Remark
2390.00	50.43	-3.57	54.00	50.33	31.86	3.92	35.68	100	19	Average
2390.00	70.00	-4.00	74.00	69.9	31.86	3.92	35.68	100	0	Peak

CH01 (Vertical)

Frequency (MHz)	Level (dBuV/m)	Over Limit (dB)	Limit Line (dBuV/m)	Read Level (dBuV)	Antenna Factor (dB)	Cable Loss (dB)	Preamp Factor (dB)	Ant Pos (cm)	Table Pos (deg)	Remark
2389.61	46.03	-7.97	54.00	45.92	31.86	3.92	35.67	126	237	Average
2389.61	65.67	-8.33	74.00	65.56	31.86	3.92	35.67	100	0	Peak

CH11 (Horizontal)

Frequency (MHz)	Level (dBuV/m)	Over Limit (dB)	Limit Line (dBuV/m)	Read Level (dBuV)	Antenna Factor (dB)	Cable Loss (dB)	Preamp Factor (dB)	Ant Pos (cm)	Table Pos (deg)	Remark
2483.50	45.77	-8.23	54.00	45.43	31.98	4.05	35.69	100	23	Average
2483.50	65.53	-8.47	74.00	65.19	31.98	4.05	35.69	100	0	Peak

CH11 (Vertical)

Frequency (MHz)	Level (dBuV/m)	Over Limit (dB)	Limit Line (dBuV/m)	Read Level (dBuV)	Antenna Factor (dB)	Cable Loss (dB)	Preamp Factor (dB)	Ant Pos (cm)	Table Pos (deg)	Remark
2483.50	48.63	-5.37	54.00	48.29	31.98	4.05	35.69	131	78	Average
2483.50	68.17	-5.83	74.00	67.83	31.98	4.05	35.69	100	0	Peak

<Sample D>

>WLAN 802.11b

CH01 (Horizontal)

Frequency (MHz)	Level (dBuV/m)	Over Limit (dB)	Limit Line (dBuV/m)	Read Level (dBuV)	Antenna Factor (dB)	Cable Loss (dB)	Preamp Factor (dB)	Ant Pos (cm)	Table Pos (deg)	Remark
2389.99	67.02	-6.98	74.00	66.92	31.86	3.92	35.68	100	0	Peak
2389.99	52.28	-1.72	54.00	52.18	31.86	3.92	35.68	100	356	Average

CH01 (Vertical)

Frequency (MHz)	Level (dBuV/m)	Over Limit (dB)	Limit Line (dBuV/m)	Read Level (dBuV)	Antenna Factor (dB)	Cable Loss (dB)	Preamp Factor (dB)	Ant Pos (cm)	Table Pos (deg)	Remark
2389.99	62.64	-11.36	74.00	62.54	31.86	3.92	35.68	100	0	Peak
2389.99	49.36	-4.64	54.00	49.26	31.86	3.92	35.68	100	230	Average

CH11 (Horizontal)

Frequency (MHz)	Level (dBuV/m)	Over Limit (dB)	Limit Line (dBuV/m)	Read Level (dBuV)	Antenna Factor (dB)	Cable Loss (dB)	Preamp Factor (dB)	Ant Pos (cm)	Table Pos (deg)	Remark
2483.47	67.17	-6.83	74.00	66.83	31.98	4.05	35.69	100	0	Peak
2483.47	41.92	-12.08	54.00	41.58	31.98	4.05	35.69	118	6	Average

CH11 (Vertical)

Frequency (MHz)	Level (dBuV/m)	Over Limit (dB)	Limit Line (dBuV/m)	Read Level (dBuV)	Antenna Factor (dB)	Cable Loss (dB)	Preamp Factor (dB)	Ant Pos (cm)	Table Pos (deg)	Remark
2483.47	65.19	-8.81	74.00	64.85	31.98	4.05	35.69	100	0	Peak
2483.47	40.1	-13.9	54.00	39.76	31.98	4.05	35.69	130	77	Average

>WLAN 802.11g

CH01 (Horizontal)

Frequency (MHz)	Level (dBuV/m)	Over Limit (dB)	Limit Line (dBuV/m)	Read Level (dBuV)	Antenna Factor (dB)	Cable Loss (dB)	Preamp Factor (dB)	Ant Pos (cm)	Table Pos (deg)	Remark
2389.99	67.73	-6.27	74.00	67.63	31.86	3.92	35.68	100	0	Peak
2389.99	49.28	-4.72	54.00	49.18	31.86	3.92	35.68	100	356	Average

CH01 (Vertical)

Frequency (MHz)	Level (dBuV/m)	Over Limit (dB)	Limit Line (dBuV/m)	Read Level (dBuV)	Antenna Factor (dB)	Cable Loss (dB)	Preamp Factor (dB)	Ant Pos (cm)	Table Pos (deg)	Remark
2389.99	65.07	-8.93	74.00	64.97	31.86	3.92	35.68	100	0	Peak
2389.99	46.82	-7.18	54.00	46.72	31.86	3.92	35.68	186	30	Average

CH11 (Horizontal)

Frequency (MHz)	Level (dBuV/m)	Over Limit (dB)	Limit Line (dBuV/m)	Read Level (dBuV)	Antenna Factor (dB)	Cable Loss (dB)	Preamp Factor (dB)	Ant Pos (cm)	Table Pos (deg)	Remark
2483.47	66.71	-7.29	74.00	66.37	31.98	4.05	35.69	100	0	Peak
2483.47	47.78	-6.22	54.00	47.44	31.98	4.05	35.69	118	10	Average

CH11 (Vertical)

Frequency (MHz)	Level (dBuV/m)	Over Limit (dB)	Limit Line (dBuV/m)	Read Level (dBuV)	Antenna Factor (dB)	Cable Loss (dB)	Preamp Factor (dB)	Ant Pos (cm)	Table Pos (deg)	Remark
2483.47	64.54	-9.46	74.00	64.2	31.98	4.05	35.69	100	0	Peak
2483.47	45.65	-8.35	54.00	45.31	31.98	4.05	35.69	105	358	Average

5.4.5 20dB Band Edge

WLAN 802.11b

CH01

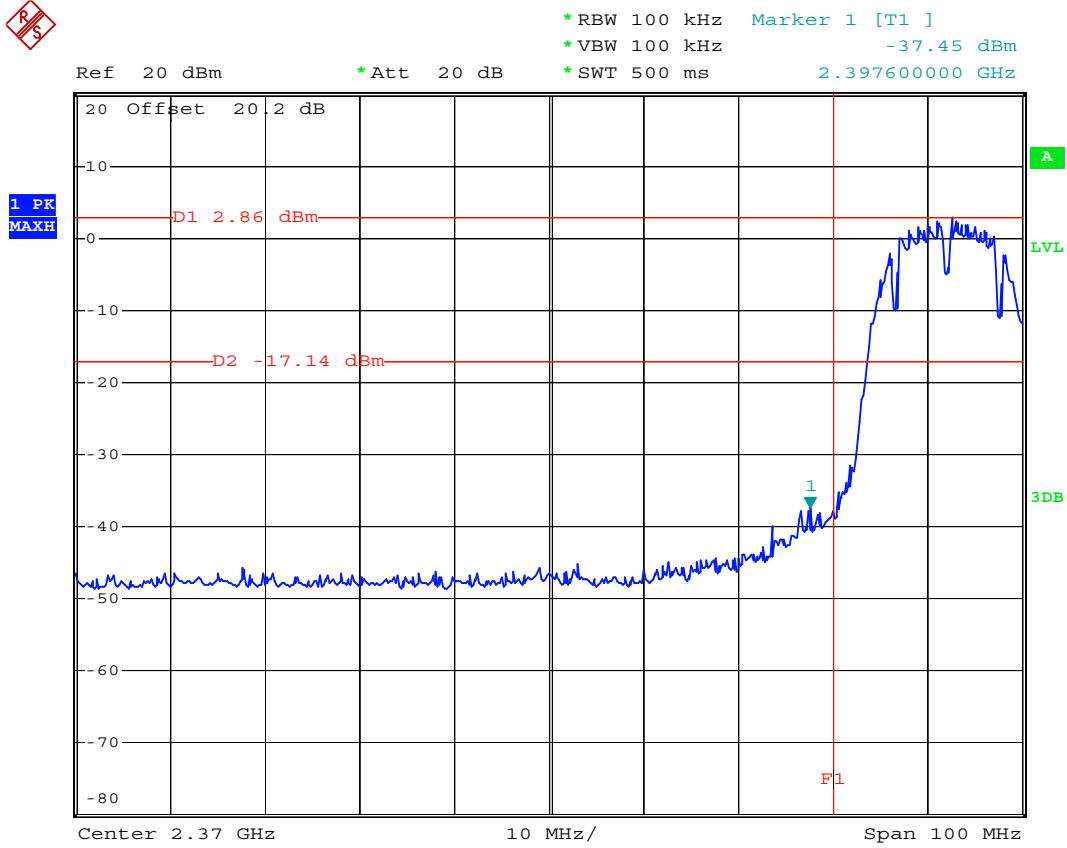

Date: 9.APR.2008 04:27:51

WLAN 802.11b

CH11

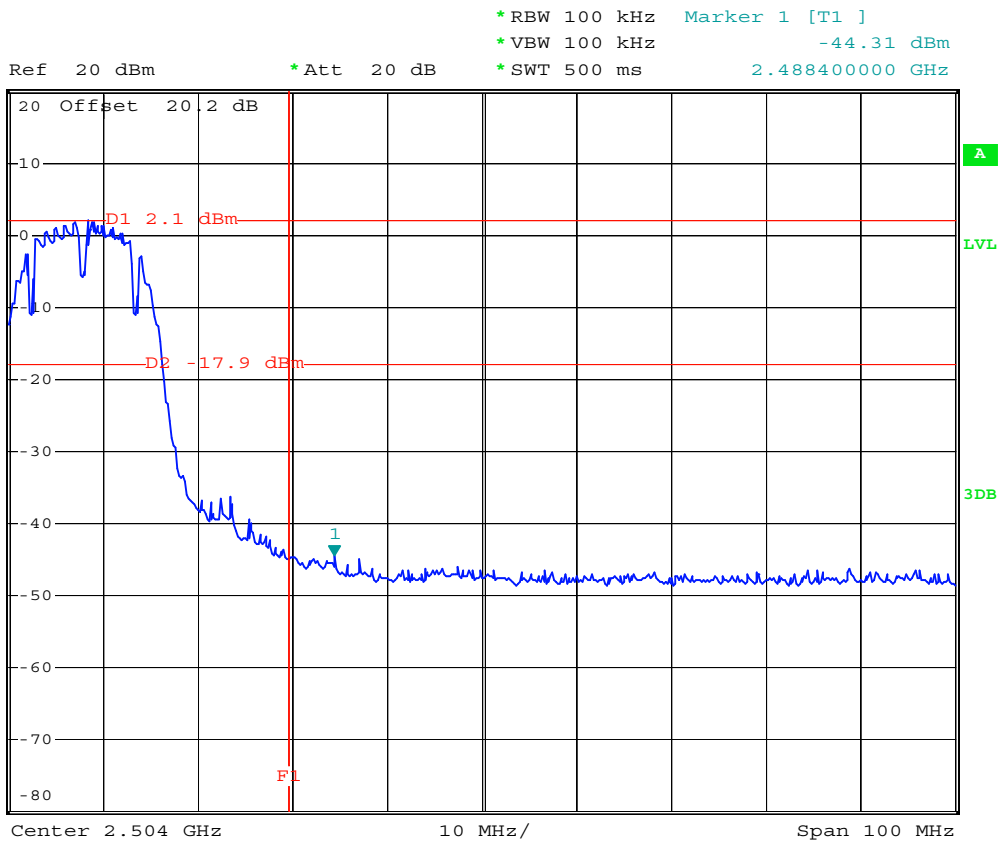

Date: 9.APR.2008 04:25:30

WLAN 802.11g

CH01



*RBW 100 kHz Marker 1 [T1]
 *VBW 100 kHz -32.09 dBm
 *SWT 500 ms 2.399800000 GHz

Ref 20 dBm

*Att 20 dB

1 PK
MAXH

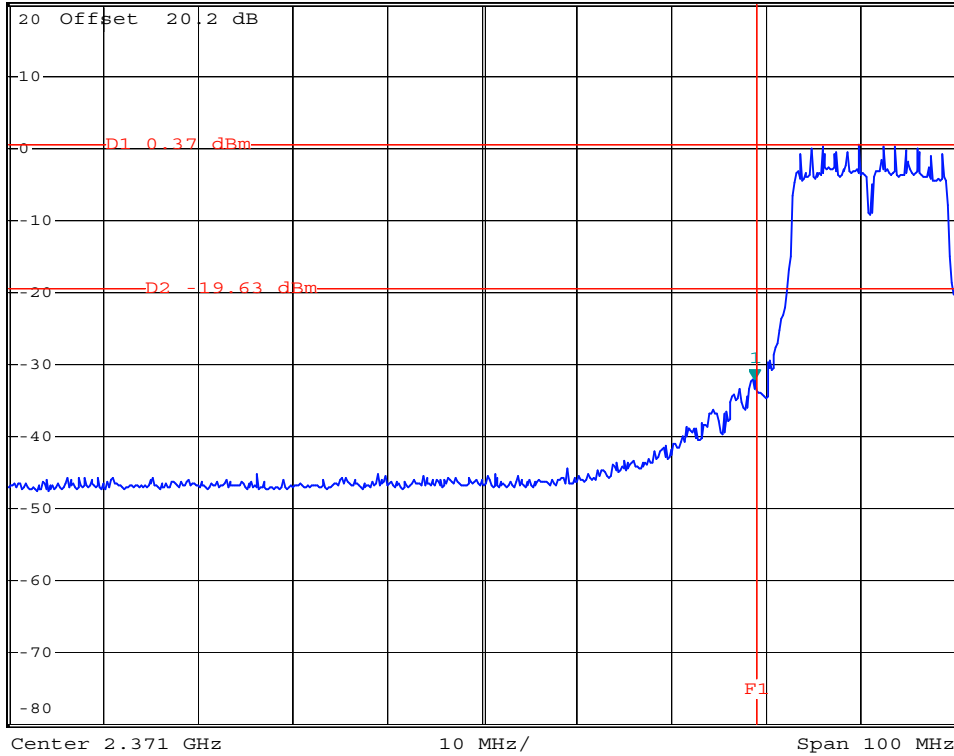

Date: 9.APR.2008 05:37:31

WLAN 802.11g

CH11

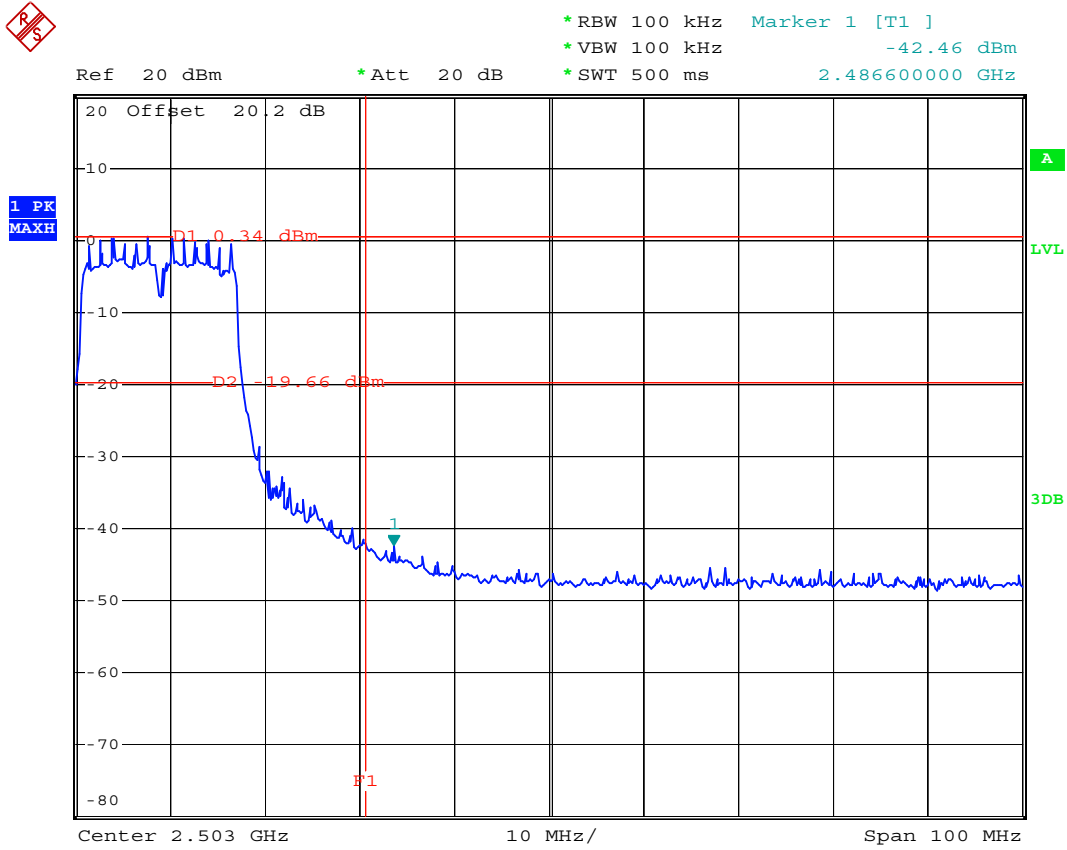

Date: 9.APR.2008 05:33:46

5.5 Peak Output Power Measurement

5.5.1 Measuring Instruments

As described in chapter 6 of this test report.

5.5.2 Test Procedure

The antenna port of the EUT was connected to a spectrum analyzer for power output measurement, according to the third method of Power Output Option 2 of Measurement of Digital Transmission Systems Operating under Section 15.247 March 23, 2005.

5.5.3 Test Setup Layout

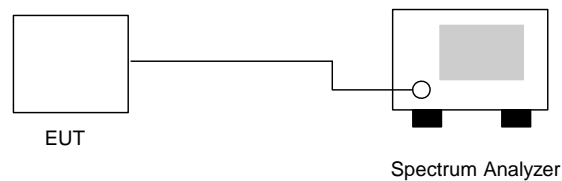

5.5.4 Test Result

- Application Type : WLAN 802.11b/g
- Temperature : 21~26
- Relative Humidity : 50~58%
- Test Enginner : Sun

WLAN 802.11b

Channel	Frequency (MHz)	Output Power (mW)	Output Power (dBm)	Limits (Watt/dBm)	Plot Ref. No.
01	2412	28.677	14.57	1W/30dBm	Plot 1
06	2437	27.128	14.33	1W/30dBm	Plot 2
11	2462	22.703	13.56	1W/30dBm	Plot 3

WLAN 802.11g

Channel	Frequency (MHz)	Output Power (mW)	Output Power (dBm)	Limits (Watt/dBm)	Plot Ref. No.
01	2412	15.712	11.96	1W/30dBm	Plot 1
06	2437	35.689	15.52	1W/30dBm	Plot 2
11	2462	15.187	11.81	1W/30dBm	Plot 3

5.5.5 Peak Output Power

Plot 1

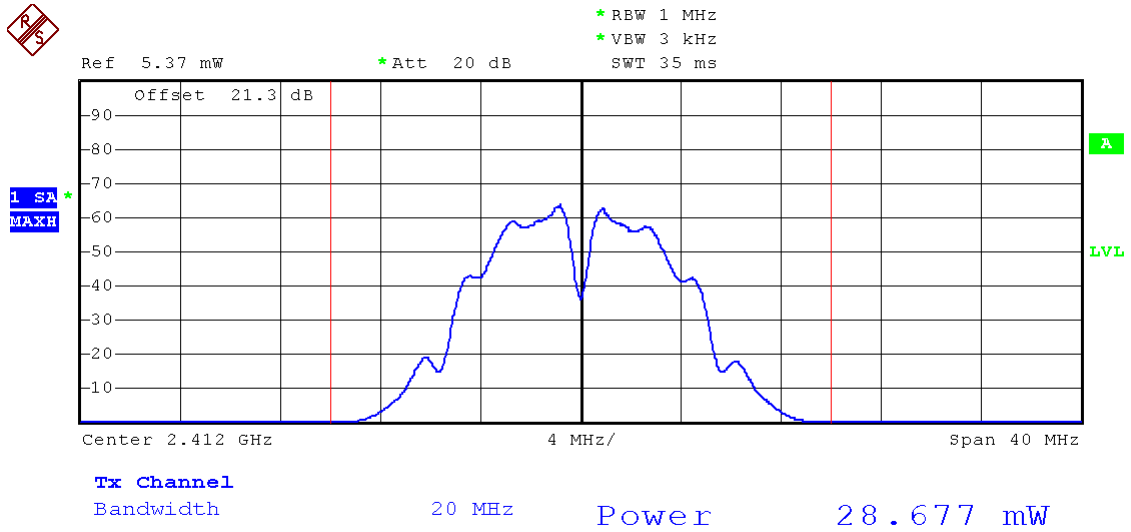

Plot 4

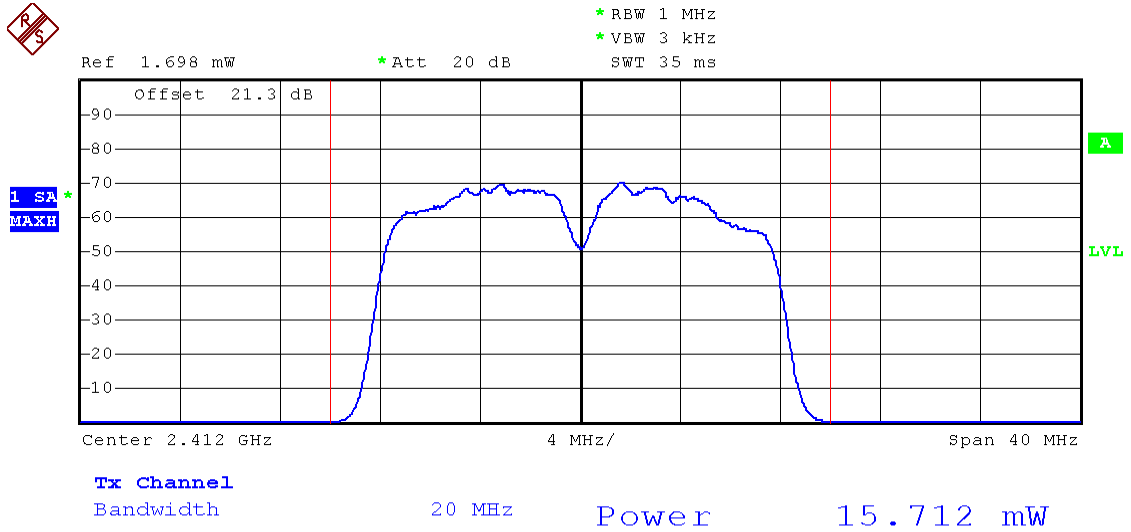

Plot 5

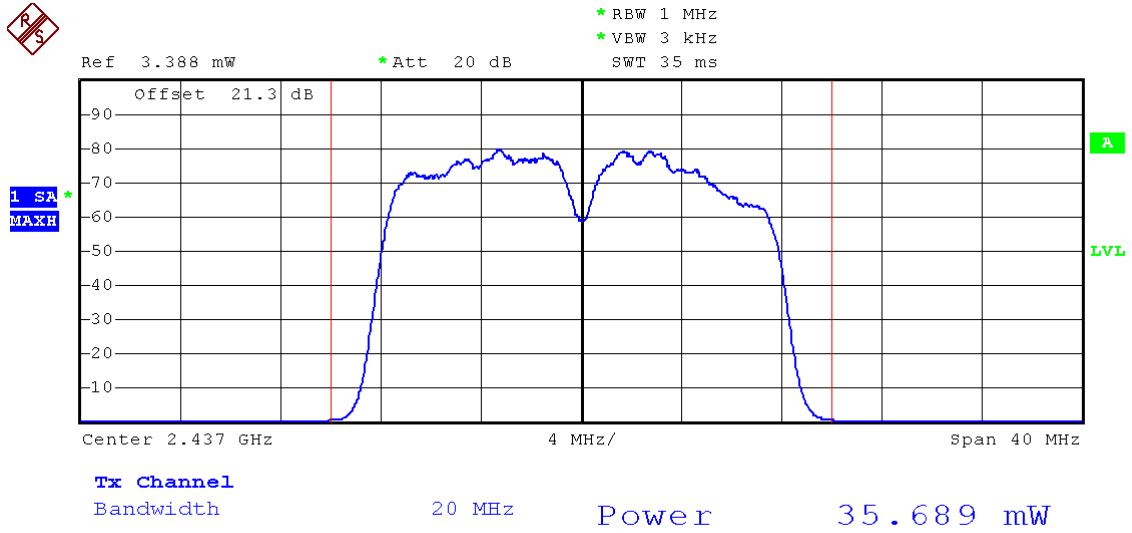

5.6 Conducted Emission

5.6.1 Measuring Instruments

As described in chapter 6 of this test Report.

The receiver setting :

150 KHz ~ 30 MHz	Detector : Quasi – Peak and Average Bandwidth : 9 KHz
------------------	--

5.6.2 Test Procedures

1. The EUT was placed 0.4 meter from the conducting wall of the shielding room was kept at least 80 centimeters from any other grounded conducting surface.
2. Connect EUT to the power port of a line impedance stabilization network (LISN).
3. All the support units are connected to the other LISN.
4. The LISN provides 50 ohm coupling impedance for the measuring instrument.
5. The FCC states that a 50 ohm, 50 microhenry LISN should be used.
6. Both sides of AC line were checked for maximum conducted interference.
7. The frequency range from 150 kHz to 30 MHz was searched.
8. Set the test-receiver system to Peak Detect Function and specified bandwidth with Maximum Hold Mode.

5.6.3 Test Data

- Test Mode: Mode 1
- Frequency Range of Test: from 0.15 MHz to 30 MHz
- Temperature: 26~27
- Relative Humidity: 58~59%
- Test Engineer: Darren
- All emissions not reported here are more than 10 dB below the prescribed limit.

The test that passed at the minimum margin was marked by a frame in the following data

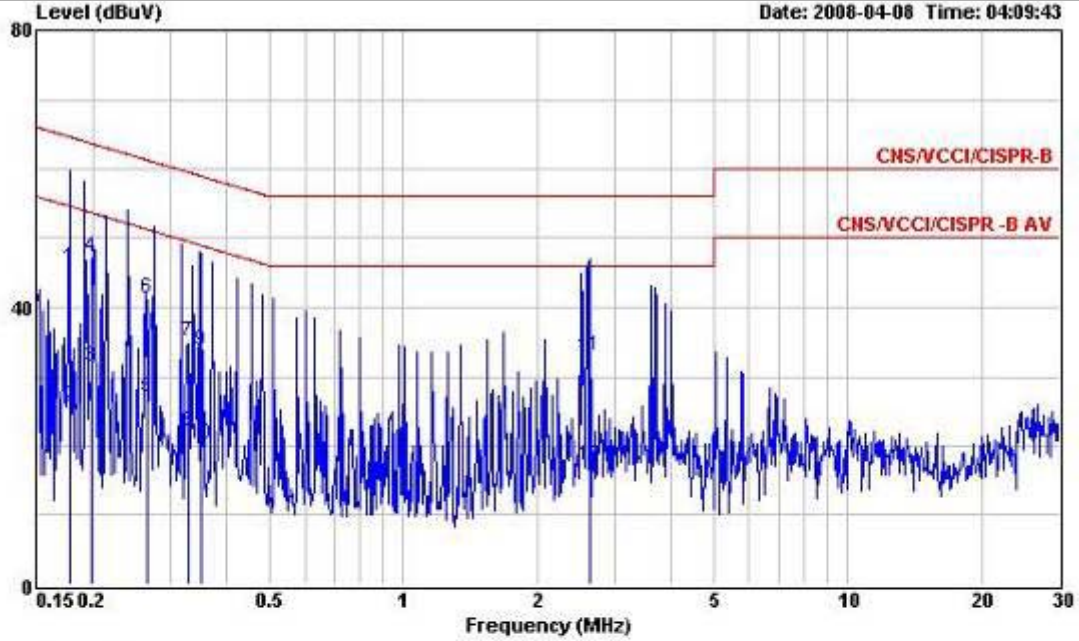

Site : C001-HY
 Condition : CNS/VCCI/CISPR-B 2001.004 200604 LINE
 EUT : MC5574 EV1 FCC submit with 1D 2D Scanner
 : and w/ camera w/o camera
 Power : 120V/60Hz
 Model : FD840317
 Memo : GSM850 Idle+BT Idle + WLAN Idle+Adaptor
 Memo : + USB Link + MPEG4 + Camera

	Freq	Level	Over	Limit	Read	Probe	Cable	
	MHz	dBuV	Limit	Line	Level	Factor	Loss	Remark
			dB	dBuV	dBuV	dB	dB	
1	0.178	45.61	-18.97	64.58	45.42	0.10	0.09	QP
2	0.178	25.79	-28.79	54.58	25.60	0.10	0.09	Average
3	0.199	31.46	-22.20	53.66	31.28	0.10	0.08	Average
4	0.199	47.28	-16.38	63.66	47.10	0.10	0.08	QP
5	0.264	26.89	-24.41	51.30	26.69	0.10	0.10	Average
6	0.264	41.32	-19.98	61.30	41.12	0.10	0.10	QP
7	0.330	35.13	-24.33	59.46	34.92	0.10	0.11	QP
8	0.330	22.16	-27.30	49.46	21.95	0.10	0.11	Average
9	0.352	33.67	-25.25	58.92	33.46	0.10	0.11	QP
10	0.352	20.20	-28.72	48.92	19.99	0.10	0.11	Average
11	2.628	33.01	-22.99	56.00	32.66	0.14	0.21	QP
12	2.628	17.15	-28.85	46.00	16.80	0.14	0.21	Average

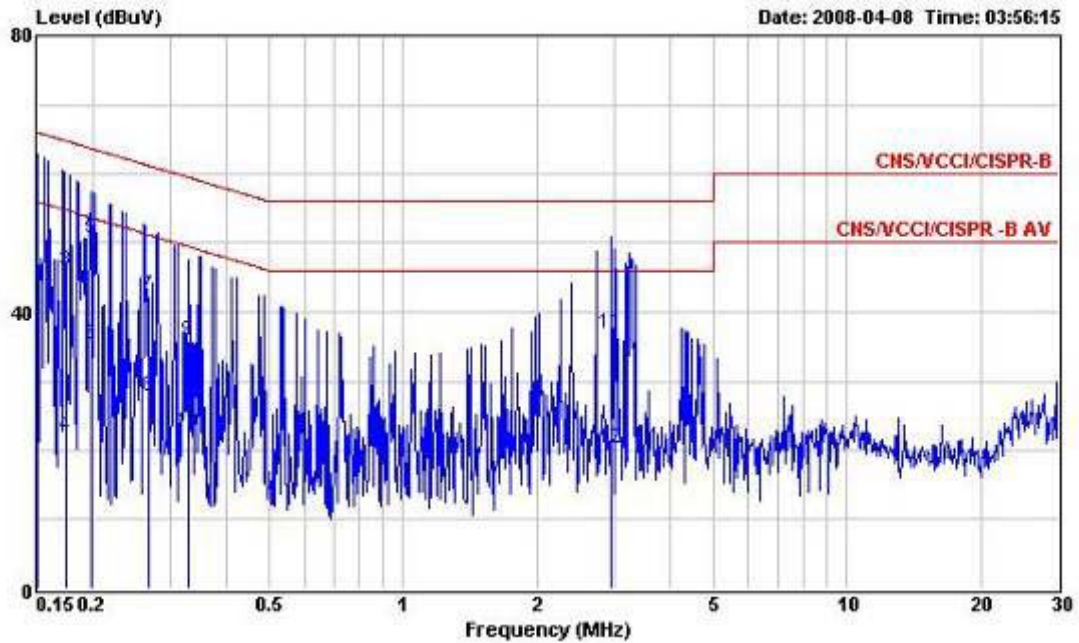

Site : CO01-HY
 Condition : CNS/VCCI/CISPR-B 2001/004 200604 NEUTRAL
 EUT : MC5574 EV1 FCC submit with 1D 2D Scanner
 : and w/ camera w/o camera
 Power : 120V/60Hz
 Model : FD840317
 Memo : GSM850 Idle+BT Idle +WLAN Idle+Adaptor
 Memo : + USB Link + MPEG4 + Camera

	Freq	Level	Over	Limit	Read	Probe	Cable	
	MHz	dBuV	Limit	Line	Level	Factor	Loss	Remark
			dB	dBuV	dBuV	dB	dB	
1	0.150	48.74	-17.24	65.98	48.54	0.10	0.10	QP
2	0.150	20.26	-45.72	65.98	20.06	0.10	0.10	Average
3	0.175	46.07	-18.67	64.74	45.88	0.10	0.09	QP
4	0.175	22.20	-42.54	64.74	22.01	0.10	0.09	Average
5	0.198	50.74	-12.94	63.68	50.56	0.10	0.08	QP
6	0.198	35.24	-28.44	63.68	35.06	0.10	0.08	Average
7	0.267	42.26	-18.97	61.23	42.06	0.10	0.10	QP
8	0.267	27.77	-33.46	61.23	27.57	0.10	0.10	Average
9	0.329	35.75	-23.73	59.48	35.54	0.10	0.11	QP
10	0.329	22.55	-36.93	59.48	22.34	0.10	0.11	Average
11	2.950	36.87	-19.13	56.00	36.52	0.10	0.25	QP
12	2.950	20.35	-35.65	56.00	20.00	0.10	0.25	Average

- Test Mode: Mode 2
- Frequency Range of Test: from 0.15 MHz to 30 MHz
- Temperature: 26~27
- Relative Humidity: 58~59%
- Test Engineer: Darren
- All emissions not reported here are more than 10 dB below the prescribed limit.

The test that passed at the minimum margin was marked by a frame in the following data

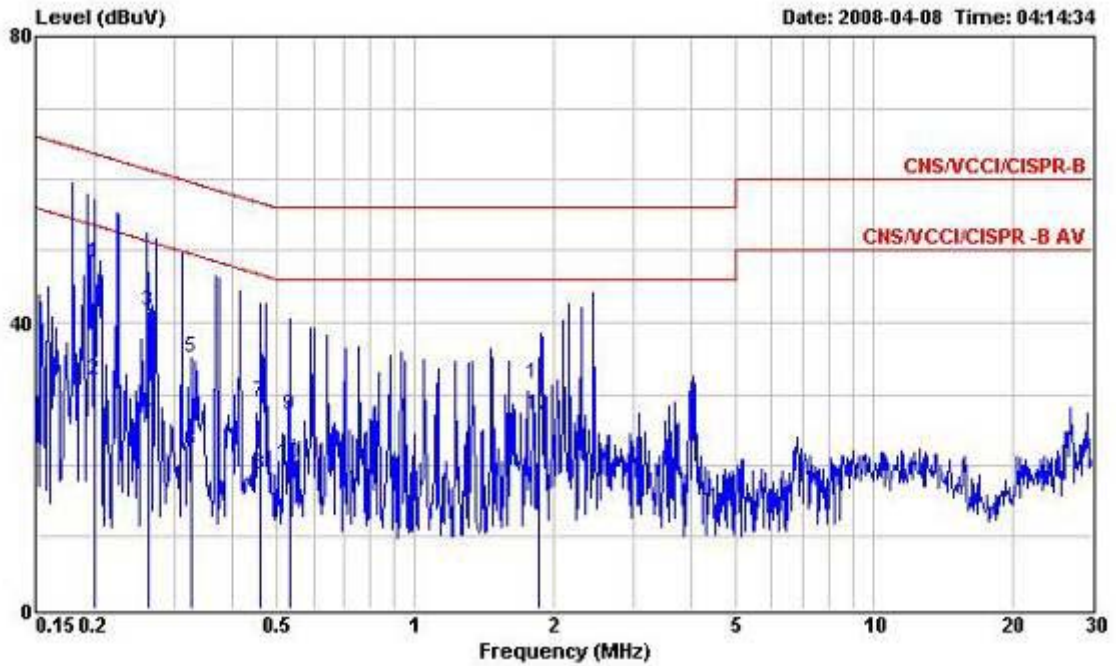

Site : C001-HY
 Condition : CNS/VCCI/CISPR-B 2001/004 200604 LINE
 EUT : MC5574 EV1 FCC submit with 1D 2D Scanner
 : and w/ camera w/o camera
 Power : 120V/60Hz
 Model : FD840317
 Memo : PCS1900 Idle+BT Idle+WLAN Idle+Adaptor
 Memo : + USB Link + MPEG4 + Scanner

	Freq	Level	Over	Limit	Read	Probe	Cable	
	MHz	dBuV	Limit	Line	Level	Factor	Loss	Remark
			dB	dBuV	dBuV	dB	dB	
1	0.200	48.40	-15.23	63.63	48.22	0.10	0.08	QP
2	0.200	32.06	-21.57	53.63	31.88	0.10	0.08	Average
3	0.262	41.44	-19.93	61.37	41.24	0.10	0.10	QP
4	0.262	27.02	-24.35	51.37	26.82	0.10	0.10	Average
5	0.327	34.95	-24.59	59.54	34.74	0.10	0.11	QP
6	0.327	22.05	-27.49	49.54	21.84	0.10	0.11	Average
7	0.459	28.85	-27.85	56.70	28.62	0.10	0.13	QP
8	0.459	18.75	-27.95	46.70	18.52	0.10	0.13	Average
9	0.532	26.90	-29.10	56.00	26.66	0.10	0.14	QP
10	0.532	20.14	-25.86	46.00	19.90	0.10	0.14	Average
11	1.868	31.45	-24.55	56.00	31.22	0.10	0.13	QP
12	1.868	27.05	-18.95	46.00	26.82	0.10	0.13	Average

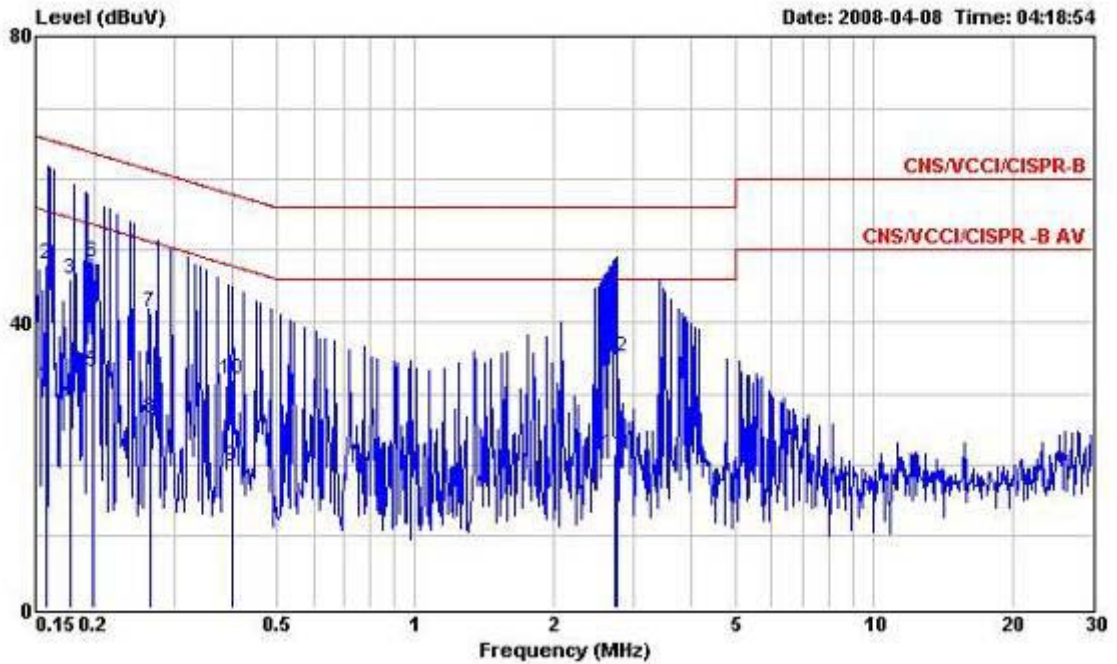

Site : CO01-HY
 Condition : CNS/VCCI/CISPR-B 2001/004 200604 NEUTRAL
 EUT : MC5574 EV1 FCC submit with 1D 2D Scanner
 : and w/ camera w/o camera
 Power : 120V/60Hz
 Model : FD840317
 Memo : PCS1900 Idle+BT Idle + WLAN Idle+Adaptor
 : + USB Link + MPEG4 + Scanner

	Freq	Level	Over	Limit	Read	Probe	Cable	
	MHz	dBuV	dB	dBuV	dBuV	dB	dB	Remark
1	0.157	31.19	-24.43	55.62	31.00	0.10	0.09	Average
2	0.157	47.93	-17.67	65.60	47.74	0.10	0.09	QP
3	0.177	45.85	-18.79	64.64	45.66	0.10	0.09	QP
4	0.177	29.09	-25.54	54.63	28.90	0.10	0.09	Average
5	0.199	33.02	-20.65	53.67	32.84	0.10	0.08	Average
6	0.199	48.26	-15.41	63.67	48.08	0.10	0.08	QP
7	0.265	41.40	-19.88	61.28	41.20	0.10	0.10	QP
8	0.265	26.49	-24.79	51.28	26.29	0.10	0.10	Average
9	0.400	19.84	-28.01	47.85	19.62	0.10	0.12	Average
10	0.400	32.00	-25.85	57.85	31.78	0.10	0.12	QP
11	2.740	21.56	-24.44	46.00	21.23	0.10	0.23	Average
12	2.743	35.03	-20.97	56.00	34.70	0.10	0.23	QP

- Test Mode: Mode 3
- Frequency Range of Test: from 0.15 MHz to 30 MHz
- Temperature: 26~27
- Relative Humidity: 58~59%
- Test Engineer: Darren
- All emissions not reported here are more than 10 dB below the prescribed limit.

The test that passed at the minimum margin was marked by a frame in the following data

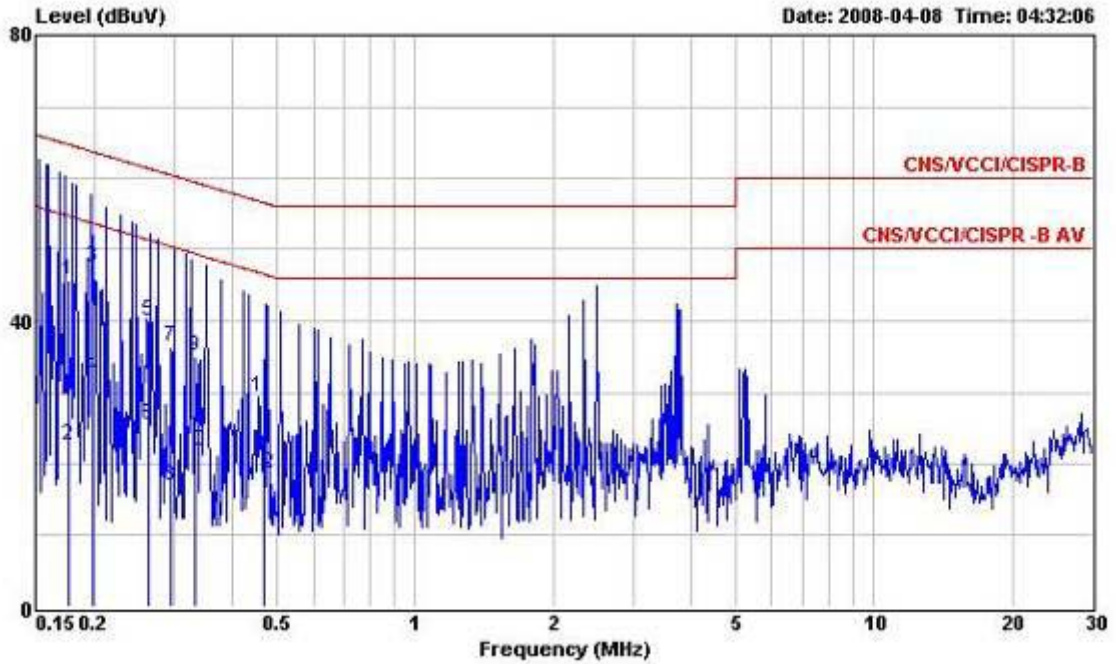

Site : CO01-HY
 Condition : CNS/VCCI/CISPR-B 2001/004 200604 LINE
 EUT : MC5574 EV1 FCC submit with 1D 2D Scanner
 : and w/ camera w/o camera
 Power : 120V/60Hz
 Model : FD840317
 Memo : EDGE Idle+BT Idle+WLAN Idle+Adaptor
 : + USB Link + MPEG4 + Scanner

	Freq	Level	Over	Limit	Read	Probe	Cable	
	MHz	dBuV	Limit	Line	Level	Factor	Loss	Remark
			dB	dBuV	dBuV	dB	dB	
1	0.176	45.75	-18.90	64.65	45.56	0.10	0.09	QP
2	0.176	22.64	-32.01	54.65	22.45	0.10	0.09	Average
3	0.199	47.44	-16.23	63.67	47.26	0.10	0.08	QP
4	0.199	32.21	-21.46	53.67	32.03	0.10	0.08	Average
5	0.264	39.90	-21.42	61.32	39.70	0.10	0.10	QP
6	0.264	25.46	-25.86	51.32	25.26	0.10	0.10	Average
7	0.294	36.42	-24.00	60.42	36.22	0.10	0.10	QP
8	0.294	17.00	-33.42	50.42	16.80	0.10	0.10	Average
9	0.332	34.99	-24.40	59.39	34.78	0.10	0.11	QP
10	0.332	21.70	-27.69	49.39	21.49	0.10	0.11	Average
11	0.467	29.27	-27.30	56.57	29.04	0.10	0.13	QP
12	0.467	18.66	-27.91	46.57	18.43	0.10	0.13	Average

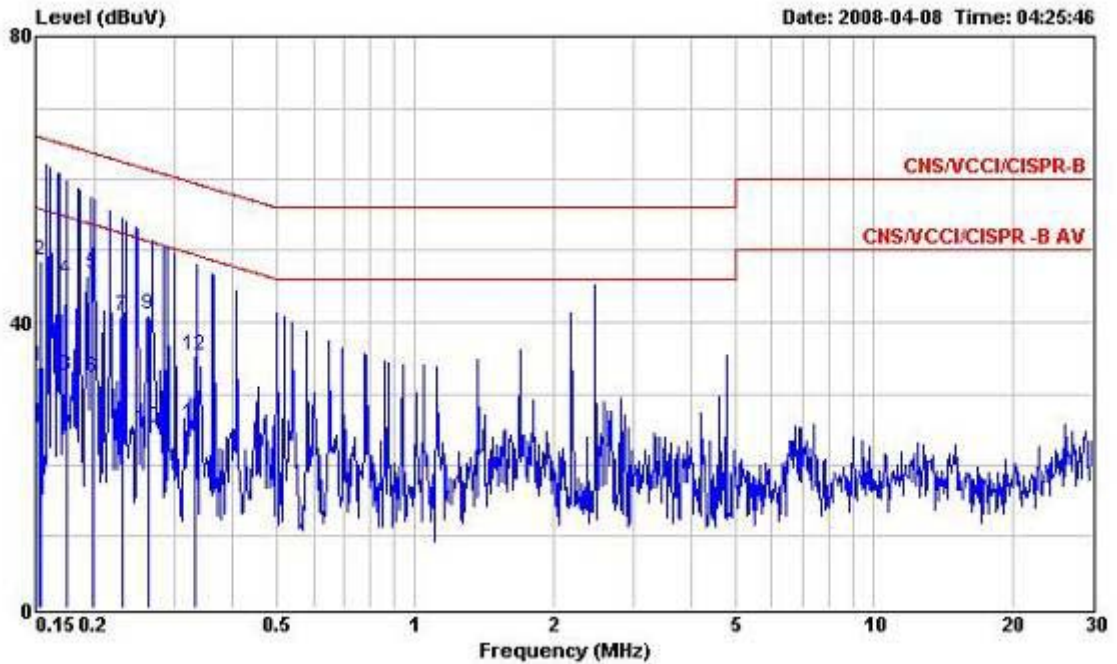

Site : CO01-HV
 Condition : CNS/VCCI/CISPR-B 2001/004 200604 NEUTRAL
 EUT : MC5574 EV1 FCC submit with 1D 2D Scanner
 : and w/ camera w/o camera
 Power : 120V/60Hz
 Model : FD840317
 Memo : EDGE Idle+BT Idle +WLAN Idle+Adaptor
 : + USB Link + MPEG4 + Scanner

	Freq	Level	Over	Limit	Read	Probe	Cable	
	MHz	dBuV	Limit	Line	Level	Factor	Loss	Remark
			dB	dBuV	dBuV	dB	dB	
1	0.152	33.85	-22.04	55.89	33.65	0.10	0.10	Average
2	0.152	48.48	-17.39	65.87	48.28	0.10	0.10	QP
3	0.174	32.48	-22.29	54.77	32.29	0.10	0.09	Average
4	0.174	46.03	-18.73	64.76	45.84	0.10	0.09	QP
5	0.199	46.80	-16.84	63.64	46.62	0.10	0.08	QP
6	0.199	32.21	-21.43	53.64	32.03	0.10	0.08	Average
7	0.231	40.67	-21.76	62.43	40.48	0.10	0.09	QP
8	0.231	24.84	-27.57	52.41	24.65	0.10	0.09	Average
9	0.264	41.04	-20.28	61.32	40.84	0.10	0.10	QP
10	0.264	25.31	-26.01	51.32	25.11	0.10	0.10	Average
11	0.332	25.84	-23.56	49.40	25.63	0.10	0.11	Average
12	0.332	35.43	-23.97	59.40	35.22	0.10	0.11	QP

- Test Mode: Mode 4
- Frequency Range of Test: from 0.15 MHz to 30 MHz
- Temperature: 26~27
- Relative Humidity: 58~59%
- Test Engineer: Darren
- All emissions not reported here are more than 10 dB below the prescribed limit.

The test that passed at the minimum margin was marked by a frame in the following data

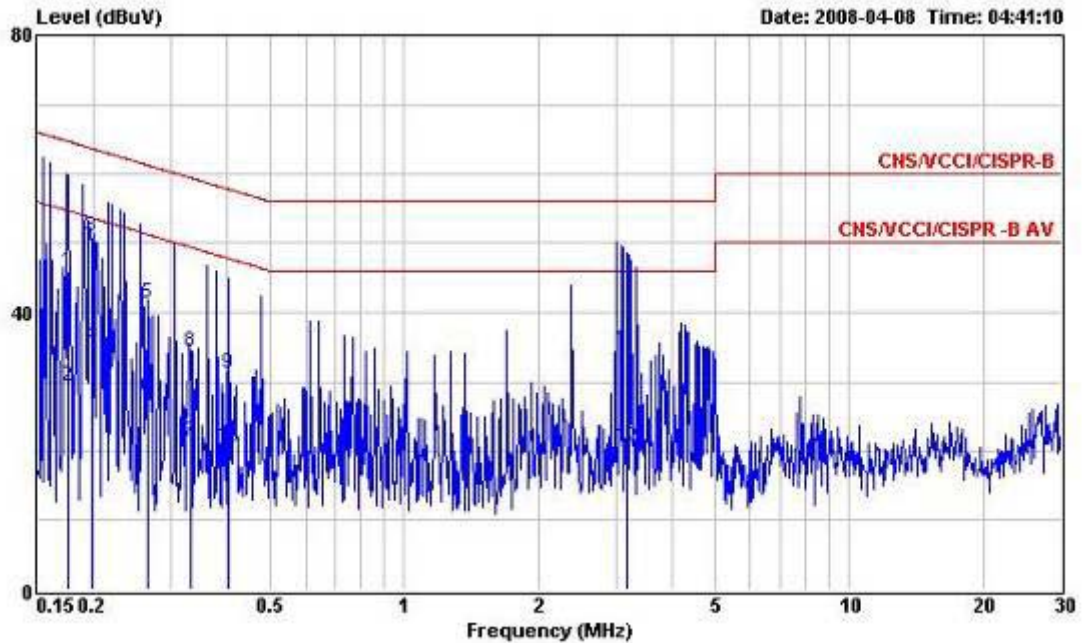

Site : CO01-HY
 Condition : CNS/VCCI/CISPR-B 2001/004 200604 LINE
 EUT : MC5574 EV1 FCC submit with 1D 2D Scanner
 : and w/ camera w/o camera
 Power : 120V/60Hz
 Model : FD840317
 Memo : GSM850 Idle+BT Link + WLAN Link+Adaptor
 Memo : + USB Link + MPEG4 + Scanner

	Freq	Level	Over	Limit	Read	Probe	Cable	
	MHz	dBuV	dB	dBuV	dBuV	dB	dB	Remark
1	0.175	45.91	-18.81	64.72	45.72	0.10	0.09	QP
2	0.175	29.31	-25.41	54.72	29.12	0.10	0.09	Average
3	0.198	50.84	-12.84	63.68	50.66	0.10	0.08	QP
4	0.198	35.14	-18.54	53.68	34.96	0.10	0.08	Average
5	0.266	41.22	-20.02	61.24	41.02	0.10	0.10	QP
6	0.266	27.77	-23.47	51.24	27.57	0.10	0.10	Average
7	0.333	21.33	-28.05	49.38	21.12	0.10	0.11	Average
8	0.333	34.25	-25.13	59.38	34.04	0.10	0.11	QP
9	0.403	31.28	-26.51	57.79	31.06	0.10	0.12	QP
10	0.403	20.42	-27.37	47.79	20.20	0.10	0.12	Average
11	3.170	34.50	-21.50	56.00	34.06	0.17	0.27	QP
12	3.170	20.44	-25.56	46.00	20.00	0.17	0.27	Average

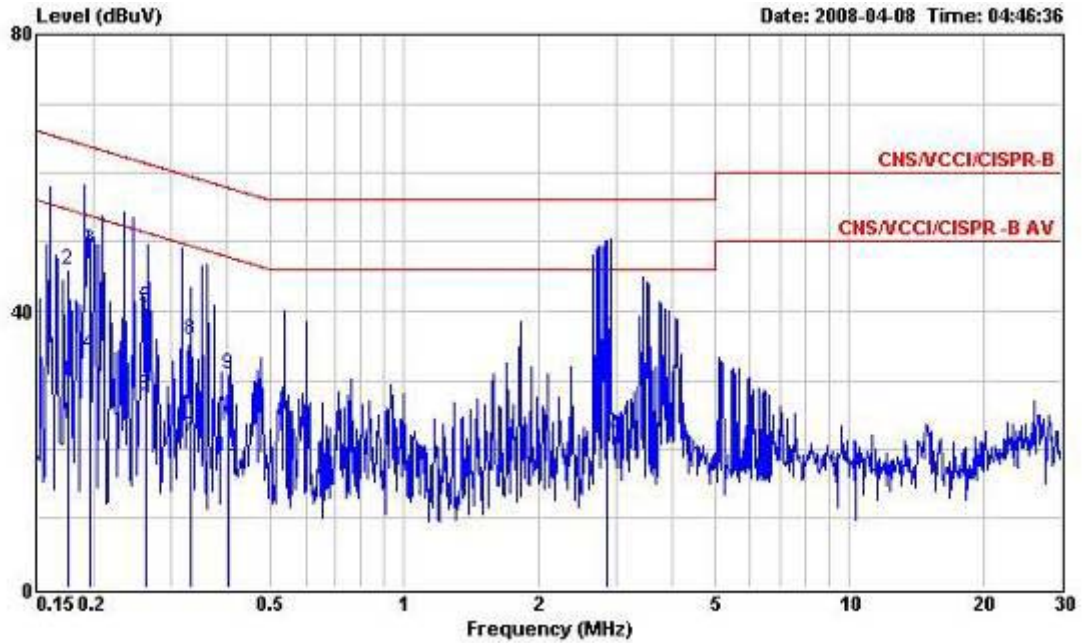

Site : CO01-HY
 Condition : CNS/VCCI/CISPR-B 2001/004 200604 NEUTRAL
 EUT : MC5574 EV1 FCC submit with 1D 2D Scanner
 : and w/ camera w/o camera
 Power : 120V/60Hz
 Model : FD840317
 Memo : GSM850 Idle+BT Link + WLAN Link+Adaptor
 Memo : + USB Link + MPEG4 + Scanner

	Freq	Level	Over	Limit	Read	Probe	Cable	
	MHz	dBuV	Limit	Line	Level	Factor	Loss	Remark
			dB	dBuV	dBuV	dB	dB	
1	0.175	29.88	-24.84	54.72	29.69	0.10	0.09	Average
2	0.175	45.93	-18.79	64.72	45.74	0.10	0.09	QP
3	0.196	48.74	-15.03	63.77	48.56	0.10	0.08	QP
4	0.196	33.71	-20.06	53.77	33.53	0.10	0.08	Average
5	0.263	40.56	-20.79	61.35	40.36	0.10	0.10	QP
6	0.263	27.89	-23.46	51.35	27.69	0.10	0.10	Average
7	0.332	21.88	-27.53	49.41	21.67	0.10	0.11	Average
8	0.332	35.75	-23.66	59.41	35.54	0.10	0.11	QP
9	0.403	31.02	-26.78	57.80	30.80	0.10	0.12	QP
10	0.403	18.90	-28.90	47.80	18.68	0.10	0.12	Average
11	2.850	36.32	-19.68	56.00	35.98	0.10	0.24	QP
12	2.850	22.47	-23.53	46.00	22.13	0.10	0.24	Average

- Test Mode: Mode 5
- Frequency Range of Test: from 0.15 MHz to 30 MHz
- Temperature: 26~27
- Relative Humidity: 58~59%
- Test Engineer: Darren
- All emissions not reported here are more than 10 dB below the prescribed limit.

The test that passed at the minimum margin was marked by a frame in the following data

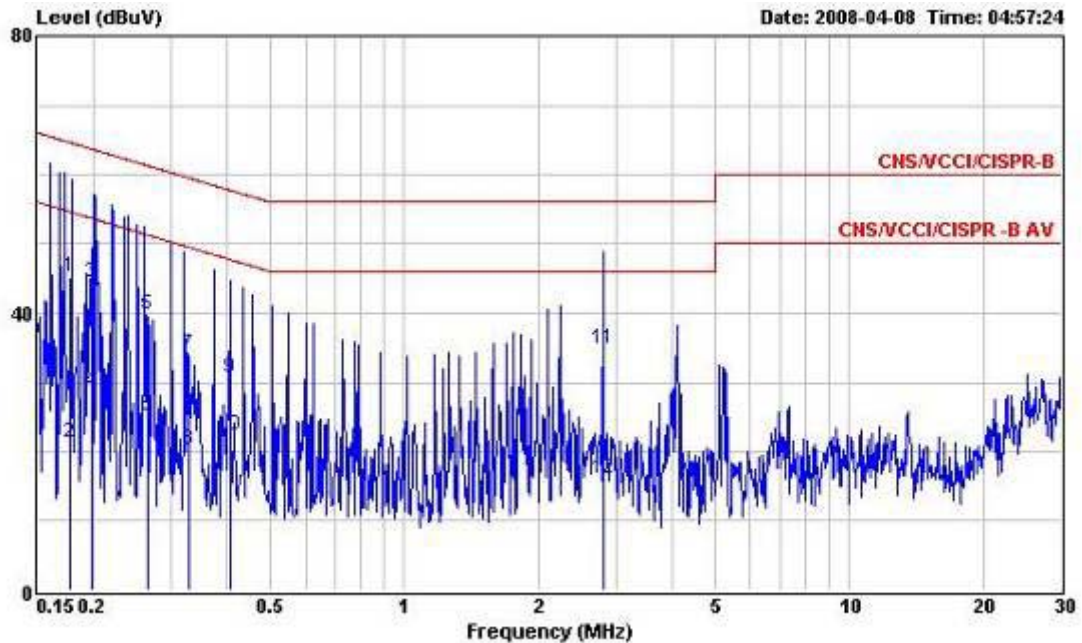

Site : CO01-HY
 Condition : CNS/VCCI/CISPR-B 2001/004 200604 LINE
 EUT : MC5574 EV1 FCC submit with 1D 2D Scanner
 : and w/ camera w/o camera
 Power : 120V/60Hz
 Model : FD840317
 Memo : GSM850 Idle+BT Link + WLAN Link+Adaptor
 Memo : + USB Link + MPEG4 + Scanner

	Freq	Level	Over	Limit	Read	Probe	Cable	
	MHz	dBuV	Limit	Line	Level	Factor	Loss	Remark
			dB	dBuV	dBuV	dB	dB	
1	0.178	45.27	-19.33	64.60	45.08	0.10	0.09	QP
2	0.178	21.31	-33.29	54.60	21.12	0.10	0.09	Average
3	0.199	44.54	-19.13	63.67	44.36	0.10	0.08	QP
4	0.199	28.49	-25.18	53.67	28.31	0.10	0.08	Average
5	0.265	39.70	-21.59	61.29	39.50	0.10	0.10	QP
6	0.265	25.15	-26.14	51.29	24.95	0.10	0.10	Average
7	0.329	34.09	-25.39	59.48	33.88	0.10	0.11	QP
8	0.329	20.27	-29.21	49.48	20.06	0.10	0.11	Average
9	0.407	30.58	-27.14	57.72	30.36	0.10	0.12	QP
10	0.407	22.32	-25.39	47.71	22.10	0.10	0.12	Average
11	2.801	34.70	-21.30	56.00	34.32	0.15	0.23	QP
12	2.801	16.08	-29.92	46.00	15.70	0.15	0.23	Average

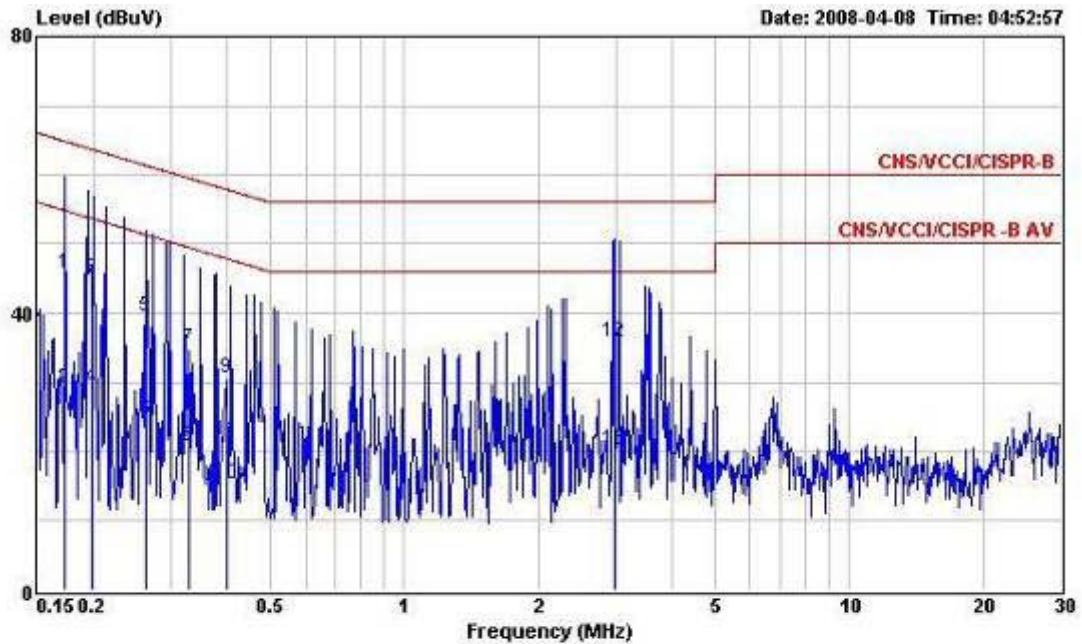

Site : CO01-HY
 Condition : CNS/VCCI/CISPR-B 2001/004 200604 NEUTRAL
 EUT : MC5574 EV1 FCC submit with 1D 2D Scanner
 and w/ camera w/o camera
 Power : 120V/60Hz
 Model : FD840317
 Memo : GSM850 Idle+BT Link +WLAN Link+Adaptor
 Memo : + USB Link + MPRG4 + Scanner

	Freq	Level	Over	Limit	Read	Probe	Cable	
	MHz	dBuV	dB	dBuV	dBuV	dB	dB	Remark
1	0.173	45.75	-19.07	64.82	45.56	0.10	0.09	QP
2	0.173	29.16	-25.66	54.82	28.97	0.10	0.09	Average
3	0.198	44.94	-18.75	63.69	44.76	0.10	0.08	QP
4	0.198	29.02	-24.67	53.69	28.84	0.10	0.08	Average
5	0.263	39.36	-21.98	61.34	39.16	0.10	0.10	QP
6	0.263	24.74	-26.60	51.34	24.54	0.10	0.10	Average
7	0.330	34.81	-24.65	59.46	34.60	0.10	0.11	QP
8	0.330	20.75	-28.71	49.46	20.54	0.10	0.11	Average
9	0.398	30.56	-27.34	57.90	30.34	0.10	0.12	QP
10	0.398	15.38	-32.52	47.90	15.16	0.10	0.12	Average
11	2.979	35.95	-20.05	56.00	35.60	0.10	0.25	QP
12	2.980	20.33	-25.67	46.00	19.98	0.10	0.25	Average

5.7 Radiated Emission Measurement

5.7.1 Measuring Instruments

As described in chapter 6 of this Report.

The spectrum analyzer setting :

30 ~ 1000 MHz	Detector : Quasi – Peak Bandwidth : 120 KHz
1 ~ 25 GHz	Detector : Peak and Average Bandwidth : 1 MHz

5.7.2 Test Procedures

1. The EUT was placed on a rotatable table top 0.8 meter above ground.
2. The EUT was set 3 meters from the interference receiving antenna which was mounted on the top of a variable height antenna tower.
3. The table was rotated 360 degrees to determine the position of the highest radiation.
4. The antenna is a broadband antenna and its height is varied between one meter and four meters above ground to find the maximum value of the field strength for both horizontal polarization and vertical polarization of the antenna.
5. For each suspected emission, the EUT was arranged to its worst case and then tune the antenna tower (from 1 m to 4 m) and turntable (from 0 degree to 360 degrees) to find the maximum reading.
6. Set the test-receiver system to Peak or CISPR quasi-peak Detect Function and specified bandwidth with Maximum Hold Mode.
7. For testing below 1GHz, If the emission level of the EUT in peak mode was 3 dB lower than the limit specified, then testing will be stopped and peak values of EUT will be reported, otherwise, the emissions will be repeated one by one using the quasi-peak method and reported.
8. For testing above 1GHz, the emission level of the EUT in peak mode was 20dB lower than average limit (that means the emission level in average mode also complies with the limit in average mode), then testing will be stopped and peak values of EUT will be reported, otherwise, the emissions will be measured in average mode again and reported.

5.7.3 Typical Test Setup Layout of Radiated Emission

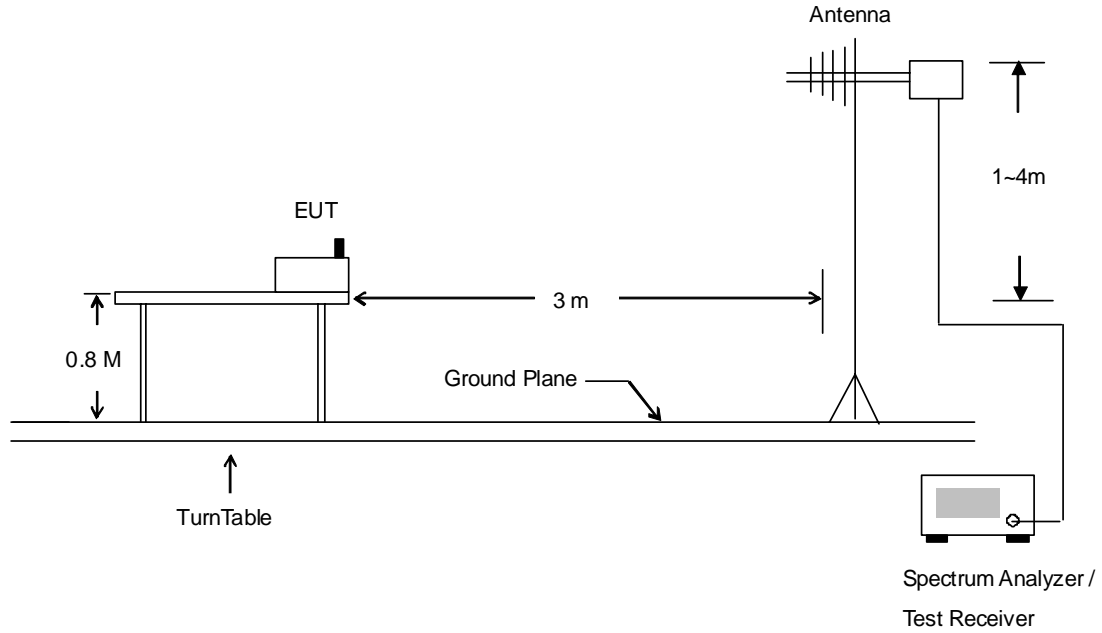

5.7.4 Test result

- Teat Model : Sample C
- Test Mode : Mode 1
- Polarization : Horizontal (30MHz-1GHz)

The test that passed at minimum margin was marked by the boldface in the following table.

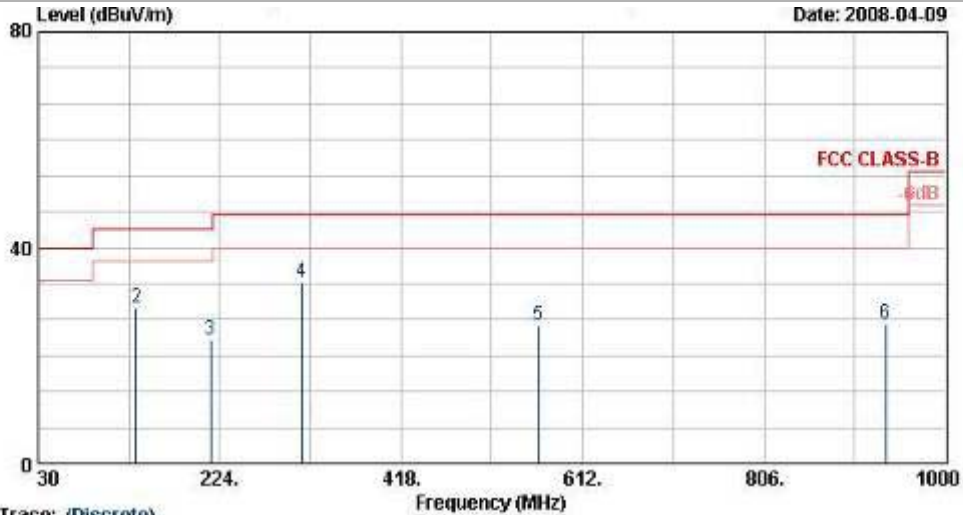

Site Condition EUT
Power Model Mode Plane

Trace: (Discrete)
03CH06-NY
FCC CLASS-B 3m LP-ANT(951121) HORIZONTAL
MC5574 EMI FCC submit with 1D 2D Scanner
and w/ camera w/o camera
120Vac/60Hz
FR 840317
11b Tx_Ch01 : 2412MHz + Adaptor
H

	Freq	Level	Over	Limit	Read	Antenna	Cable	Preamp	Ant	Table	Remark
	MHz	dBUV/m	Limit	Line	Level	Factor	Loss	Factor	Pos	Pos	
			dB	dBUV/m	dBUV	dB/n	dB	dB	cm	deg	
1	30.00	21.24	-18.76	40.00	34.78	19.66	0.30	33.50	---	---	Peak
2	134.49	28.87	-14.63	43.50	50.75	11.05	0.50	33.43	---	---	Peak
3	214.14	22.78	-20.72	43.50	45.48	10.16	0.64	33.50	---	---	Peak
4	311.90	33.51	-12.49	46.00	52.48	13.53	0.80	33.30	100	152	Peak
5	565.30	25.59	-20.41	46.00	39.52	18.11	1.00	33.03	---	---	Peak
6	936.30	25.81	-20.19	46.00	36.36	20.79	1.20	32.54	---	---	Peak

- Polarization : Horizontal (1GHz-25GHz)

The test that passed at minimum margin was marked by the boldface in the following table.

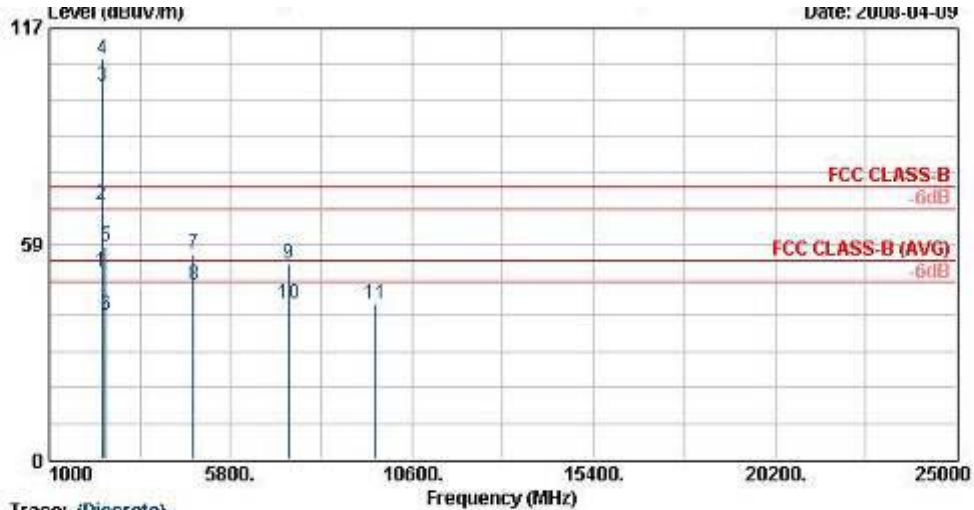

Site
Condition
EUT
Power
Model
Mode
Plane

Trace: (Discrete)
03CH06-HY
FCC CLASS-B 3m SHF-EHF HORN HORIZONTAL
MC5574 EMI FCC submit with ID 2D Scanner
and w/ camera w/o camera
120Vac/60Hz
FR 840317
11b Tx_Ch01 , 2412MHz + Adaptor
R

	Freq	Level	Over	Limit	Read	Antenna	Cable	Preamp	Ant	Table	Remark
	MHz	dBuV/m	Limit	Line	Level	Factor	Loss	Factor	Pos	Pos	
			dB	dBuV/m	dBuV	dB/m	dB	dB	cn	deg	
1 !	2390.00	50.98	-3.02	54.00	50.88	31.86	3.92	35.68	100	356	Average
2 !	2390.00	69.23	-4.77	74.00	69.13	31.86	3.92	35.68	100	0	Peak
3 @	2412.00	101.26			101.11	31.88	3.95	35.68	100	356	Average
4 X	2412.00	108.60			108.45	31.88	3.95	35.68	100	0	Peak
5	2494.00	57.76	-16.24	74.00	57.41	32.00	4.05	35.70	100	0	Peak
6	2494.00	39.16	-14.84	54.00	38.81	32.00	4.05	35.70	100	356	Average
7	4821.00	55.73	-18.27	74.00	51.50	34.13	5.77	35.67	100	0	Peak
8	4821.00	47.44	-6.56	54.00	43.21	34.13	5.77	35.67	100	325	Average
9	7332.00	53.27	-20.73	74.00	46.52	35.67	7.21	36.13	100	0	Peak
10	7332.00	42.01	-11.99	54.00	35.26	35.67	7.21	36.13	100	211	Average
11	9642.00	42.07	-31.93	74.00	80.95	-10.09	7.94	36.73	100	0	Peak

Remark: #3 and #4 are Fundamental Signals.

- Polarization : Vertical (30MHz-1GHz)

The test that passed at minimum margin was marked by the boldface in the following table.

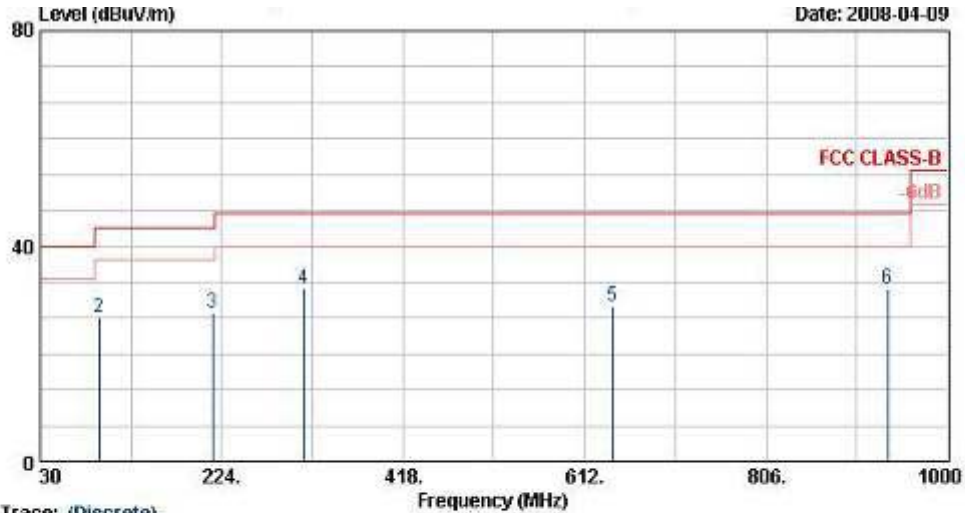

Site
Condition
EUT
Power
Model
Mode
Plane

Trace: (Discrete)
03CH06-RY
FCC CLASS-B 3m LF-ANT(951121) VERTICAL
MC5574 EMI FCC submit with ID 2D Scanner
and w/ camera w/o camera
120Vac/60Hz
FR 840317
11b Tx_Ch01 . 2412MHz + Adaptor
N

	Freq	Level	Over	Limit	ReadAntenna	Cable	Preamp	Ant	Table	Remark
	MHz	dBuV/m	Limit	Line	Level	Loss	Factor	Pos	Pos	
			dB	dBuV/m	dBuV	dB	dB	cn	deg	
1	30.00	22.51	-17.49	40.00	36.05	19.66	0.30	33.50	---	Peak
2	92.64	26.75	-16.75	43.50	49.97	9.62	0.50	33.33	---	Peak
3	214.14	27.73	-15.77	43.50	50.44	10.16	0.64	33.50	---	Peak
4	311.90	31.99	-14.01	46.00	50.96	13.53	0.80	33.30	---	Peak
5	642.30	28.92	-17.08	46.00	42.16	18.65	1.10	32.99	---	Peak
6	936.30	32.26	-13.74	46.00	42.81	20.79	1.20	32.54	100	213 Peak

- Polarization : Vertical (1GHz-25GHz)

The test that passed at minimum margin was marked by the boldface in the following table.

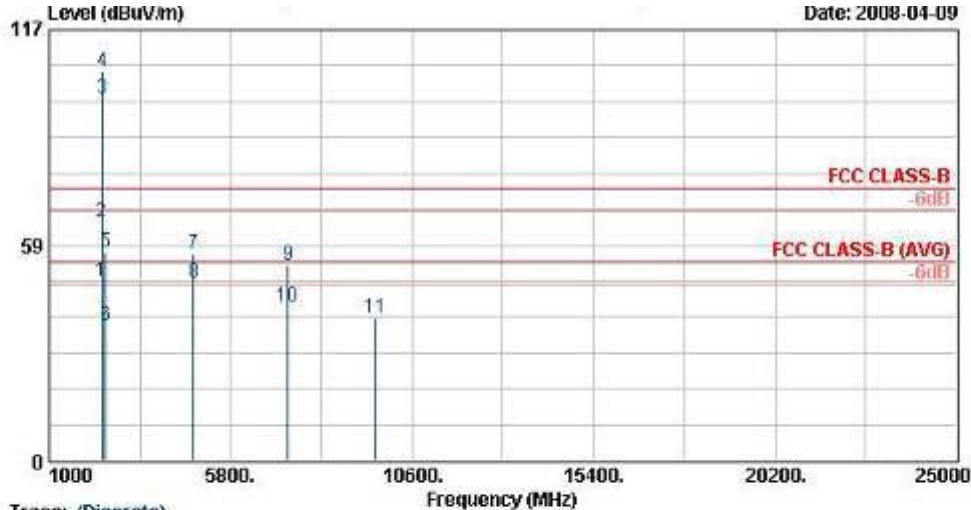

Site
Condition
EUT
Power
Model
Mode
Plane

Trace: (Discrete)
03CND6-WY
FCC CLASS-B 3m SHF-EHF HORN VERTICAL
MC5574 EYI FCC submit with 1D 2D Scanner
and w/ camera w/o camera
120Vac/50Hz
FR 840317
11b Tx_Ch01 - 2412MHz + Adaptor
H

	Freq	Level	Over	Limit	Read	Antenna	Cable	Preamp	Ant	Table	Remark
	MHz	dBuV/m	Limit	Line	Level	Factor	Loss	Factor	Pos	Pos	
			dB	dBuV/m	dBuV	dB/n	dB	dB	cn	deg	
1 !	2390.00	48.62	-5.38	54.00	48.52	31.86	3.92	35.68	100	238	Average
2	2390.00	64.86	-9.14	74.00	64.76	31.86	3.92	35.68	100	0	Peak
3 @	2412.00	98.18			98.03	31.88	3.95	35.68	100	238	Average
4 X	2412.00	105.53			105.38	31.88	3.95	35.68	100	0	Peak
5	2492.00	56.38	-17.62	74.00	56.03	32.00	4.05	35.70	100	0	Peak
6	2492.00	36.42	-17.58	54.00	36.07	32.00	4.05	35.70	100	238	Average
7	4821.00	56.16	-17.84	74.00	51.93	34.13	5.77	35.67	100	0	Peak
8 !	4821.00	48.39	-5.61	54.00	44.16	34.13	5.77	35.67	100	69	Average
9	7326.00	53.20	-20.80	74.00	46.46	35.67	7.21	36.13	100	0	Peak
10	7326.00	41.92	-12.08	54.00	35.17	35.67	7.21	36.13	100	119	Average
11	9642.00	38.89	-35.11	74.00	77.76	-10.09	7.94	36.73	100	0	Peak

Remark: #3 and #4 are Fundamental Signals.

- Teat Model : Sample C
- Test Mode : Mode 2
- Polarization : Horizontal (30MHz-1GHz)

The test that passed at minimum margin was marked by the boldface in the following table.

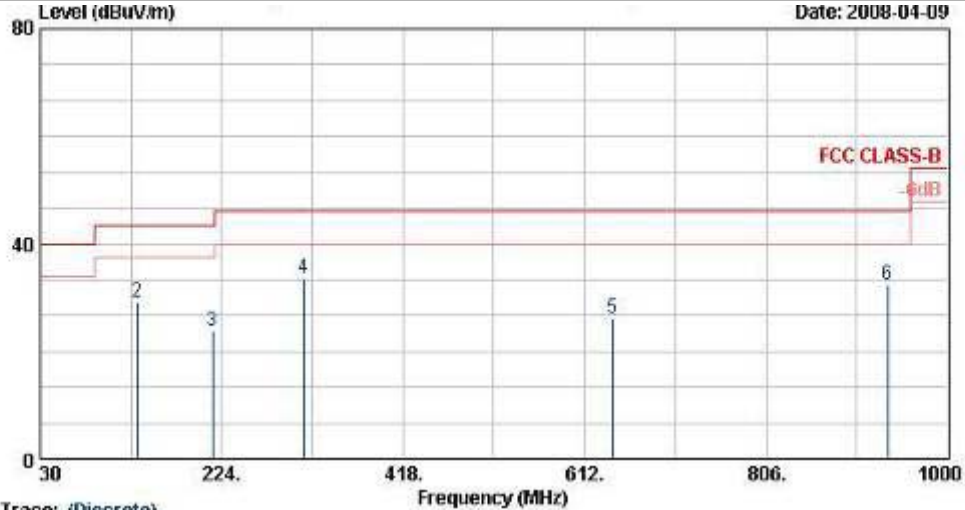

Trace: (Discrete)

Site: 03CR06-RY
 Condition: FCC CLASS-B 3m LF-ANT(951121) HORIZONTAL
 EUT: MCS574 EV1 FCC submit with ID 2D Scanner and w/ camera w/o camera
 Power: 120Vac/60Hz
 Model: FR 840317
 Mode: 11b Tx_Ch06 . 2437MHz + Adaptor
 Plane: R

	Freq	Level	Over	Limit	Read	Antenna	Cable	Preamp	Ant	Table	Remark
	MHz	dBuV/m	Limit	Line	Level	Factor	Loss	Factor	Pos	Pos	
			dB	dBuV/m	dBuV	dB/m	dB	dB	cn	deg	
1	30.00	21.93	-18.07	40.00	35.47	19.66	0.30	33.50	---	---	Peak
2	133.68	29.08	-14.42	43.50	50.76	11.21	0.50	33.40	---	---	Peak
3	214.14	23.78	-19.72	43.50	46.48	10.16	0.64	33.50	---	---	Peak
4	311.90	33.59	-12.41	46.00	52.56	13.53	0.80	33.30	100	125	Peak
5	642.30	26.06	-19.94	46.00	39.30	18.65	1.10	32.99	---	---	Peak
6	936.30	32.40	-13.60	46.00	42.95	20.79	1.20	32.54	---	---	Peak

- Polarization : Horizontal (1GHz-25GHz)

The test that passed at minimum margin was marked by the boldface in the following table.

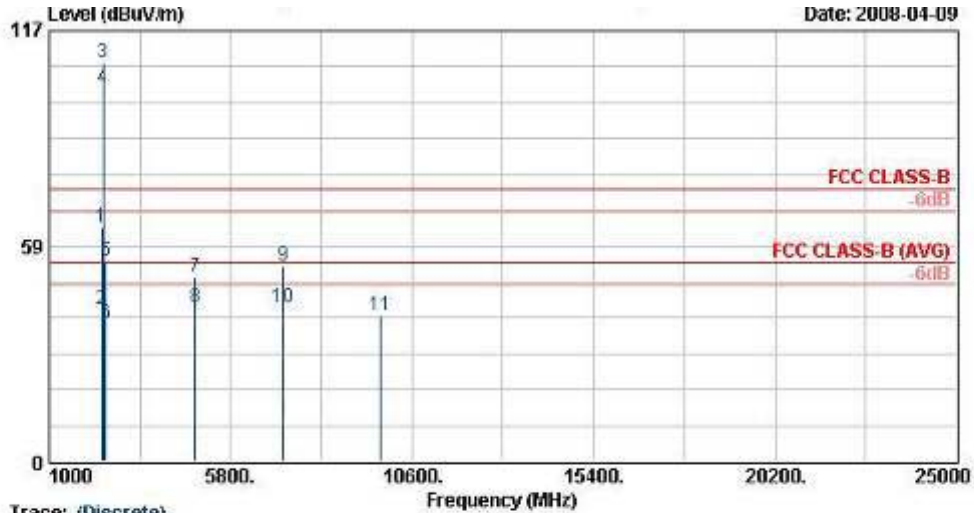

Site
Condition
EUT

Power
Model
Mode
Plane

Trace: (Discrete)
03CR06-RY
FCC CLASS-B 3m SHF-EHF HORN HORIZONTAL
MC5574 EMI FCC submit with ID 2D Scanner
and w/ camera w/o camera
120Vac/60Hz
FR 840317
11b Tx_Ch06 . 2437MHz + Adaptor
H

	Freq	Level	Over	Limit	Read	Antenna	Cable	Preamp	Ant	Table	Remark
	MHz	dBuV/m	Limit	Line	Level	Factor	Loss	Factor	Pos	Pos	
			dB	dBuV/m	dBuV	dB/m	dB	dB	cn	deg	
1	2380.00	63.53	-10.47	74.00	63.45	31.83	3.92	35.68	100	0	Peak
2	2380.00	41.50	-12.50	54.00	41.42	31.83	3.92	35.68	100	352	Average
3 X	2437.00	108.39			108.16	31.93	3.99	35.69	100	0	Peak
4 @	2437.00	101.14			100.91	31.93	3.99	35.69	100	352	Average
5	2500.00	54.43	-19.57	74.00	54.08	32.00	4.05	35.70	100	0	Peak
6	2500.00	37.54	-16.46	54.00	37.19	32.00	4.05	35.70	100	352	Average
7	4872.00	50.14	-23.86	74.00	45.84	34.15	5.80	35.65	100	0	Peak
8	4872.00	41.77	-12.23	54.00	37.47	34.15	5.80	35.65	100	321	Average
9	7191.00	52.92	-21.08	74.00	46.11	35.72	7.16	36.08	100	0	Peak
10	7191.00	41.84	-12.16	54.00	35.04	35.72	7.16	36.08	100	213	Average
11	9747.00	39.54	-34.46	74.00	78.15	-9.85	7.98	36.75	100	0	Peak

Remark: #3 and #4 are Fundamental Signals.

- Polarization : Vertical (30MHz-1GHz)

The test that passed at minimum margin was marked by the boldface in the following table.

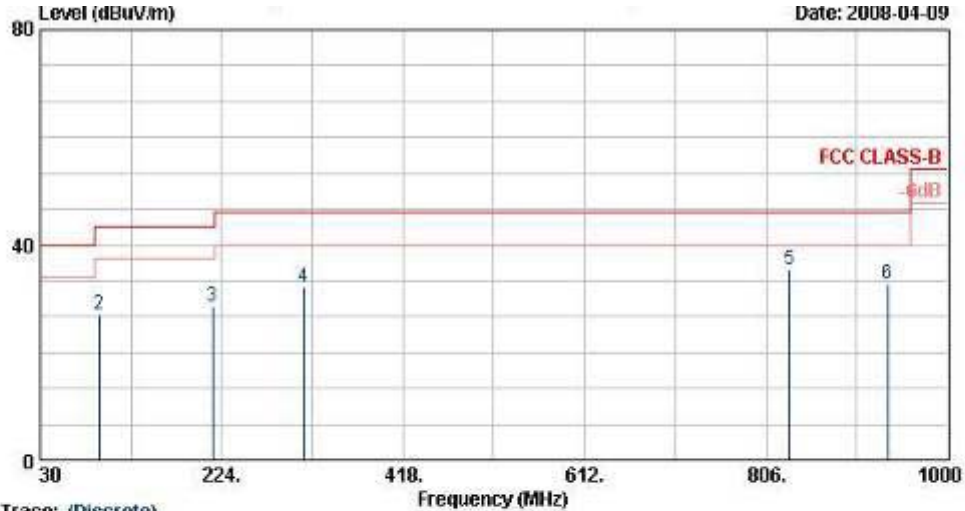

Site
Condition
EUT
Power
Model
Mode
Plane

Trace: (Discrete)
03CH06-RY
FCC CLASS-B 3m I/F-ANT(951121) VERTICAL
MC5574 EMI FCC submit with ID 2D Scanner
and w/ camera w/o camera
120Vac/60Hz
FR 840317
11b Tx_Ch06 , 2437MHz + Adaptor
H

	Freq	Level	Over	Limit	ReadAntenna	Cable	Preamp	Ant	Table	Remark
	MHz	dBuV/m	Limit	Line	Level	Loss	Factor	Pos	Pos	
			dB	dBuV/m	dBuV	dB	dB	cn	deg	
1	30.00	22.05	-17.95	40.00	35.59	19.66	0.30	33.50	---	Peak
2	92.64	27.17	-16.33	43.50	50.38	9.62	0.50	33.33	---	Peak
3	214.14	28.48	-15.02	43.50	51.18	10.16	0.64	33.50	---	Peak
4	311.90	31.98	-14.02	46.00	50.95	13.53	0.80	33.30	---	Peak
5	831.30	35.36	-10.64	46.00	46.76	20.04	1.20	32.63	100	246 Peak
6	936.30	32.80	-13.20	46.00	43.35	20.79	1.20	32.54	---	Peak

- Polarization : Vertical (1GHz-25GHz)

The test that passed at minimum margin was marked by the boldface in the following table.

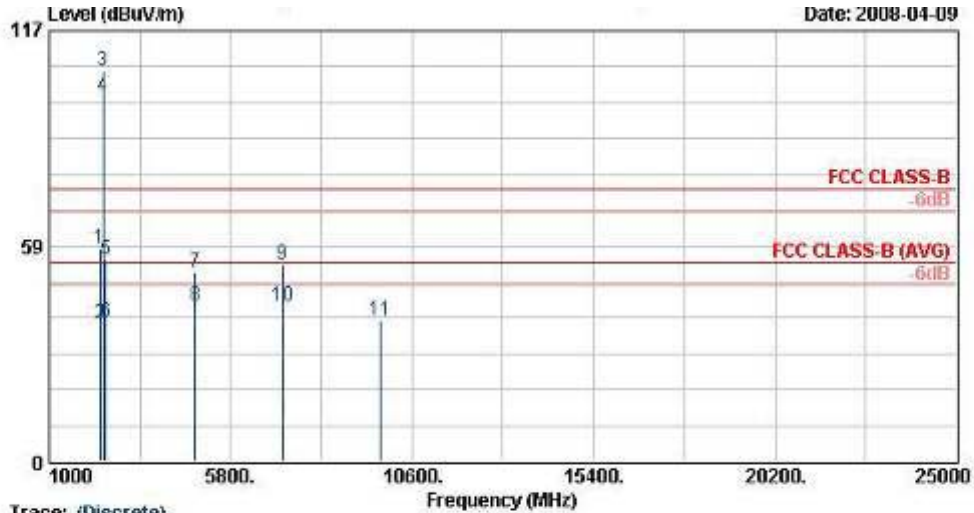

Site
Condition
EUT

Power
Model
Mode
Plane

Trace: (Discrete)
03CR06-RY
FCC CLASS-B 3m SHF-EHF HORN VERTICAL
MC5574 EMI FCC submit with ID 2D Scanner
and w/ camera w/o camera
120Vac/60Hz
FR 840317
11b Tx_Ch06 . 2437MHz + Adaptor
H

	Freq	Level	Over	Limit	Read	Antenna	Cable	Preamp	Ant	Table	Remark
	MHz	dBuV/m	Limit	Line	Level	Factor	Loss	Factor	Pos	Pos	
			dB	dBuV/m	dBuV	dB/m	dB	dB	cm	deg	
1	2342.00	57.92	-16.08	74.00	57.95	31.78	3.86	35.67	100	0	Peak
2	2342.00	37.22	-16.78	54.00	37.25	31.78	3.86	35.67	124	240	Average
3 X	2437.00	106.31			106.08	31.93	3.99	35.69	100	0	Peak
4 @	2437.00	99.15			98.92	31.93	3.99	35.69	124	240	Average
5	2500.00	54.73	-19.27	74.00	54.38	32.00	4.05	35.70	100	0	Peak
6	2500.00	37.80	-16.20	54.00	37.45	32.00	4.05	35.70	124	240	Average
7	4872.00	51.46	-22.54	74.00	47.16	34.15	5.80	35.65	100	0	Peak
8	4872.00	41.98	-12.02	54.00	37.68	34.15	5.80	35.65	100	261	Average
9	7161.00	53.30	-20.70	74.00	46.48	35.74	7.15	36.07	100	0	Peak
10	7161.00	42.08	-11.92	54.00	35.26	35.74	7.15	36.07	100	156	Average
11	9747.00	38.14	-35.86	74.00	78.75	-9.85	7.98	36.75	100	0	Peak

Remark: #3 and #4 are Fundamental Signals.

- Teat Model : Sample C
- Test Mode : Mode 3
- Polarization : Horizontal (30MHz-1GHz)

The test that passed at minimum margin was marked by the boldface in the following table.

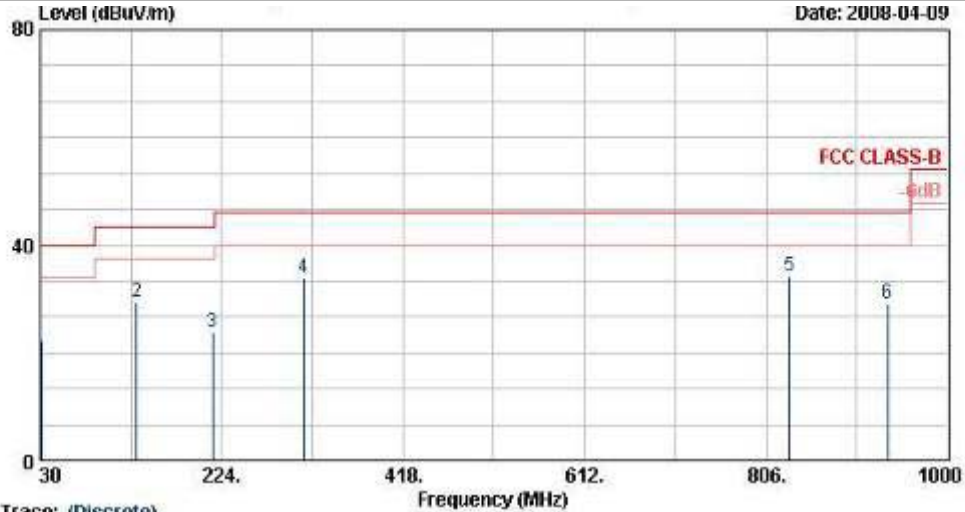

Site Condition EUT
Power Model Mode Plane

Trace: (Discrete)
03CH06-HY
FCC CLASS-B 3m LF-ANT(951121) HORIZONTAL
MC5574 EMI FCC submit with ID 2D Scanner
and w/ camera w/o camera
120Vac/60Hz
FR 840317
11b Tx_Ch11 . 2462MHz + Adaptor
H

	Freq	Level	Over	Limit	Read	Antenna	Cable	Preamp	Ant	Table	Remark
	MHz	dBuV/m	Limit	Line	Level	Factor	Loss	Factor	Pos	Pos	
			dB	dBuV/m	dBuV	dB/n	dB	dB	cn	deg	
1	31.08	22.44	-17.56	40.00	36.65	18.95	0.30	33.46	---	---	Peak
2	133.14	29.53	-13.97	43.50	51.01	11.37	0.50	33.36	---	---	Peak
3	214.14	23.80	-19.70	43.50	46.51	10.16	0.64	33.50	---	---	Peak
4	311.90	33.95	-12.05	46.00	52.92	13.53	0.80	33.30	---	---	Peak
5	831.30	34.24	-11.76	46.00	45.64	20.04	1.20	32.63	100	192	Peak
6	936.30	29.12	-16.88	46.00	39.67	20.79	1.20	32.54	---	---	Peak

- Polarization : Horizontal (1GHz-25GHz)

The test that passed at minimum margin was marked by the boldface in the following table.

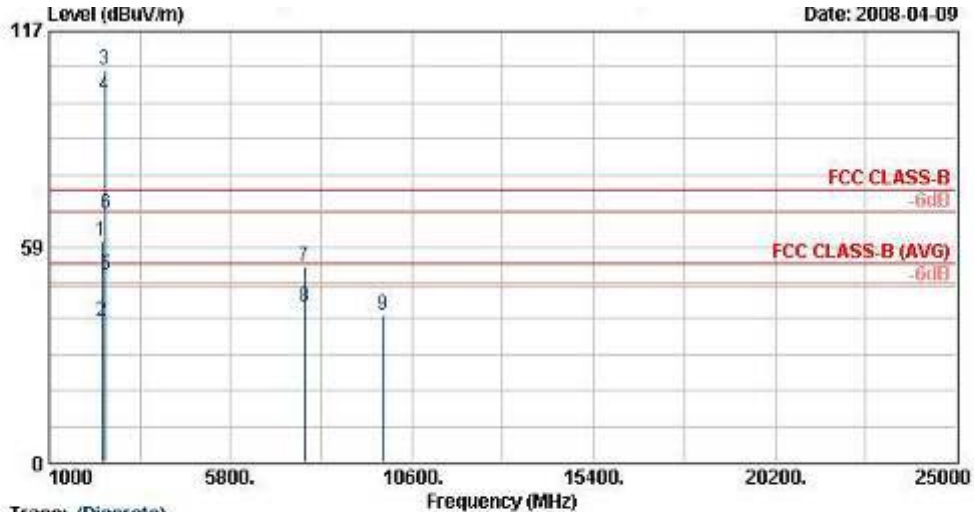

Site
Condition
EUT
Power
Model
Mode
Plane

Trace: (Discrete)
03CND6-RY
FCC CLASS-B 3m SHF-EHF HORN HORIZONTAL
MC5574 EMI FCC submit with ID 2D Scanner
and w/ camera w/o camera
120Vac/60Hz
FR 840317
11b Tx_Ch11 , 2462MHz + Adaptor
R

	Freq	Level	Over	Limit	Read	Antenna	Cable	Preamp	Ant	Table	Remark
	MHz	dBuV/m	Limit	Line	Level	Factor	Loss	Factor	Pos	Pos	
			dB	dBuV/m	dBuV	dB/m	dB	dB	cm	deg	
1	2390.00	59.82	-14.18	74.00	59.72	31.88	3.92	35.68	100	0	Peak
2	2390.00	38.39	-15.61	54.00	38.29	31.88	3.92	35.68	119	24	Average
3 X	2462.00	106.68			106.40	31.95	4.02	35.69	100	0	Peak
4 @	2462.00	99.75			99.47	31.95	4.02	35.69	119	24	Average
5 †	2483.50	50.98	-3.02	54.00	50.65	31.98	4.05	35.70	119	24	Average
6	2483.50	67.61	-6.39	74.00	67.28	31.98	4.05	35.70	100	0	Peak
7	7761.00	53.12	-20.88	74.00	46.32	35.65	7.40	36.25	100	0	Peak
8	7761.00	42.01	-11.99	54.00	35.21	35.65	7.40	36.25	100	182	Average
9	9846.00	39.89	-34.11	74.00	78.25	-9.63	8.04	36.77	100	0	Peak

Remark: #3 and #4 are Fundamental Signals.

- Polarization : Vertical (30MHz-1GHz)

The test that passed at minimum margin was marked by the boldface in the following table.

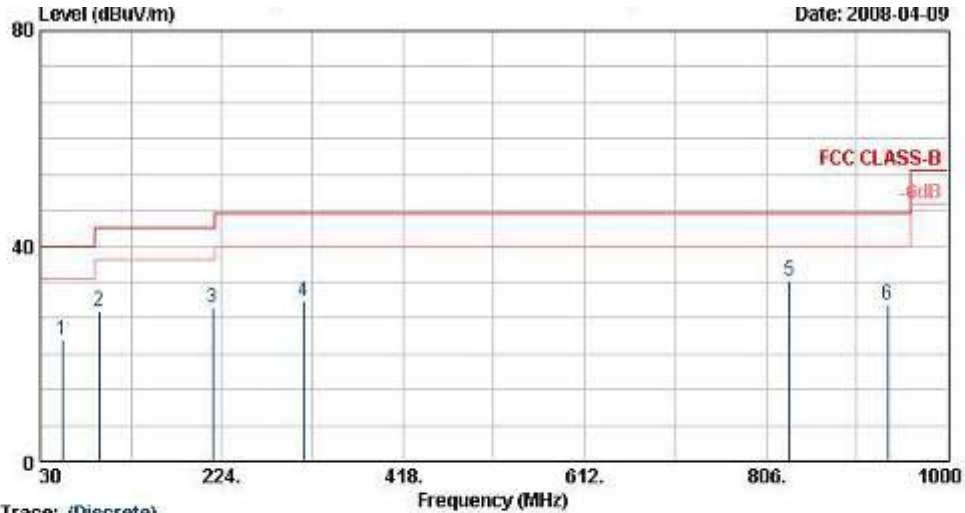

Site
Condition
EUT

Power
Model
Mode
Plane

Trace: (Discrete)
03CR06-RV
FCC CLASS-B 3m LF-ANT(951121) VERTICAL
MC5574 EVI FCC submit with ID 2D Scanner
and w/ camera w/o camera
120Vac/60Hz
FP 840317
11b Tx_Ch11 . 2462MHz + Adaptor
W

	Freq	Level	Over	Limit	ReadAntenna	Cable	Preamp	Ant	Table	Remark
	MHz	dBUV/m	Limit	Line	Level	Loss	Factor	Pos	Pos	
			dB	dBUV/m	dBUV	dB	dB	cn	deg	
1	53.49	22.57	-17.43	40.00	47.85	7.64	0.36	33.28	---	Peak
2	92.64	27.85	-15.65	43.50	51.06	9.62	0.50	33.33	---	Peak
3	214.14	28.54	-14.96	43.50	51.25	10.16	0.64	33.50	---	Peak
4	311.90	29.77	-16.23	46.00	48.74	13.53	0.80	33.30	---	Peak
5	831.30	33.50	-12.50	46.00	44.89	20.04	1.20	32.63	100	172 Peak
6	936.30	29.23	-16.77	46.00	39.79	20.79	1.20	32.54	---	Peak

- Polarization : Vertical (1GHz-25GHz)

The test that passed at minimum margin was marked by the boldface in the following table.

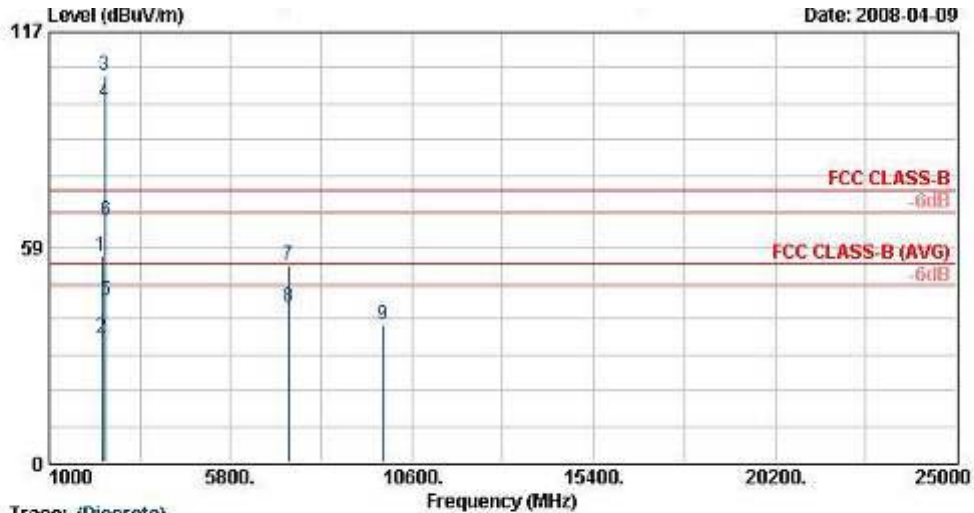

Site
Condition
EUT

Power
Model
Mode
Plane

Trace: (Discrete)
03CR06-RV
FCC CLASS-B 3m SHF-EHF HORN VERTICAL
MC5574 EVI FCC submit with ID 2D Scanner
and w/ camera w/o camera
120Vac/60Hz
FR 840317
11b Tx_Ch11 , 2462MHz + Adaptor
H

	Freq	Level	Over	Limit	ReadAntenna	Cable	Preamp	Ant	Table	Remark
	MHz	dBUV/m	Limit	Line	Level	Loss	Factor	Pos	Pos	
			dB	dBUV/m	dBUV	dB	dB	cn	deg	
1	2390.00	56.16	-17.84	74.00	56.07	31.86	3.92	35.68	100	0 Peak
2	2390.00	34.08	-19.92	54.00	33.98	31.86	3.92	35.68	120	233 Average
3 X	2462.00	105.15			104.87	31.95	4.02	35.69	100	0 Peak
4 @	2462.00	98.02			97.74	31.95	4.02	35.69	120	233 Average
5	2483.50	43.88	-10.12	54.00	43.55	31.98	4.05	35.70	120	233 Average
6	2483.50	65.66	-8.34	74.00	65.33	31.98	4.05	35.70	100	0 Peak
7	7347.00	53.41	-20.59	74.00	46.67	35.66	7.21	36.14	100	0 Peak
8	7347.00	42.22	-11.78	54.00	35.49	35.66	7.21	36.14	100	216 Average
9	9846.00	37.60	-36.40	74.00	75.97	-9.63	8.04	36.77	100	0 Peak

Remark: #3 and #4 are Fundamental Signals.

- Teat Model : Sample C
- Test Mode : Mode 4
- Polarization : Horizontal (30MHz-1GHz)

The test that passed at minimum margin was marked by the boldface in the following table.

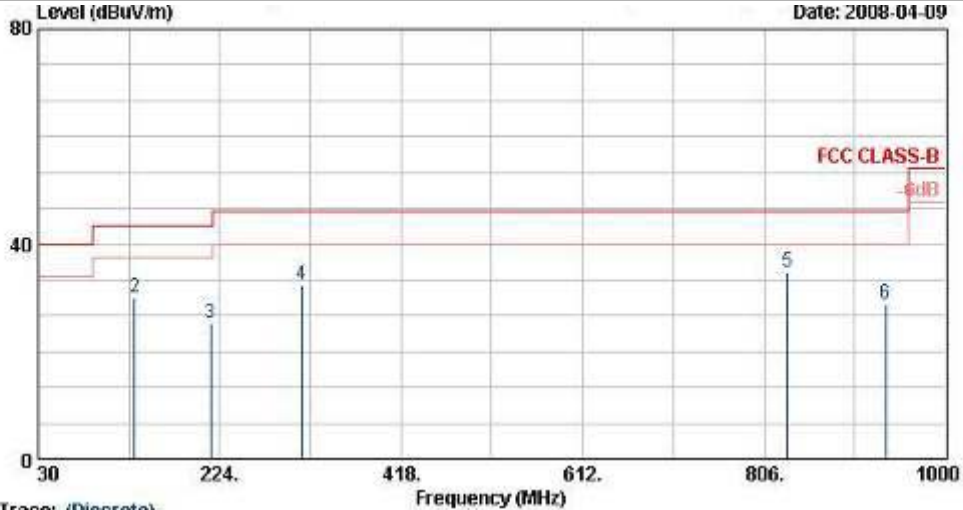

Site : 03C806-RY
 Condition : FCC CLASS-B 3m LF-ANT(951121) HORIZONTAL
 EUT : MCS574 EVI FCC submit with ID 2D Scanner and w/ camera w/o camera
 Power : 120Vac/60Hz
 Model : FR 840317
 Mode : I1g Tx_Ch01 . 2412MHz + Adaptor
 Plane : N

Trace: (Discrete)

	Freq	Level	Over	Limit	Read	Antenna	Cable	Preamp	Ant	Table	Remark
	MHz	dBuV/m	dB	dBuV/m	dBuV	dB/m	dB	dB	cn	deg	
1	30.00	21.87	-18.13	40.00	35.41	19.66	0.30	33.50	---	---	Peak
2	133.14	29.99	-13.51	43.50	51.47	11.37	0.50	33.36	---	---	Peak
3	214.14	25.17	-18.33	43.50	47.87	10.16	0.64	33.50	---	---	Peak
4	311.90	32.55	-13.45	46.00	51.52	13.53	0.80	33.30	---	---	Peak
5 @	831.30	34.94	-11.06	46.00	46.33	20.04	1.20	32.63	100	143	Peak
6	936.30	28.95	-17.05	46.00	39.50	20.79	1.20	32.54	---	---	Peak

- Polarization : Horizontal (1GHz-25GHz)

The test that passed at minimum margin was marked by the boldface in the following table.

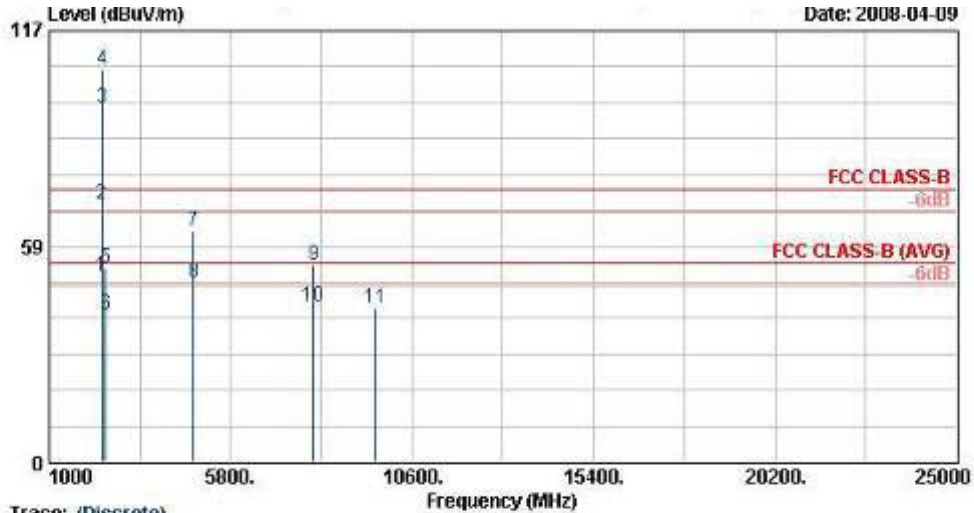

Site Condition EUT
Power Model Mode Plane

Trace: (Discrete)
03CH06-HY
FCC CLASS-B 3m SHF-EHF HORN HORIZONTAL
MC5574 EMI FCC submit with ID 2D Scanner and w/ camera w/o camera
120Vac/60Hz
FR 840317
11g Tx_Ch01, 2412MHz + Adaptor
H

	Freq	Level	Over Limit	Limit Line	Read Level	Antenna Factor	Cable Loss	Preamp Factor	Ant Pos	Table Pos	Remark
	MHz	dBuV/m	dB	dBuV/m	dBuV	dB/m	dB	dB	cn	deg	
1 @	2390.00	50.43	-3.57	54.00	50.33	31.86	3.92	35.68	100	19	Average
2 @	2390.00	70.00	-4.00	74.00	69.90	31.86	3.92	35.68	100	0	Peak
3 @	2412.00	96.26			96.11	31.88	3.95	35.68	100	19	Average
4 @	2412.00	106.55			106.40	31.88	3.95	35.68	100	0	Peak
5	2500.00	52.64	-21.36	74.00	52.29	32.00	4.05	35.70	100	0	Peak
6	2500.00	39.83	-14.17	54.00	39.48	32.00	4.05	35.70	100	19	Average
7	4821.00	62.60	-11.40	74.00	58.37	34.13	5.77	35.67	100	0	Peak
8 @	4821.00	48.87	-5.13	54.00	44.64	34.13	5.77	35.67	100	326	Average
9	8001.00	53.56	-20.44	74.00	46.64	35.70	7.52	36.30	100	0	Peak
10	8001.00	42.28	-11.72	54.00	35.36	35.70	7.52	36.30	100	104	Average
11	9651.00	41.60	-32.40	74.00	80.46	-10.07	7.94	36.73	100	0	Peak

Remark: #3 and #4 are Fundamental Signals.

- Polarization : Vertical (30MHz-1GHz)

The test that passed at minimum margin was marked by the boldface in the following table.

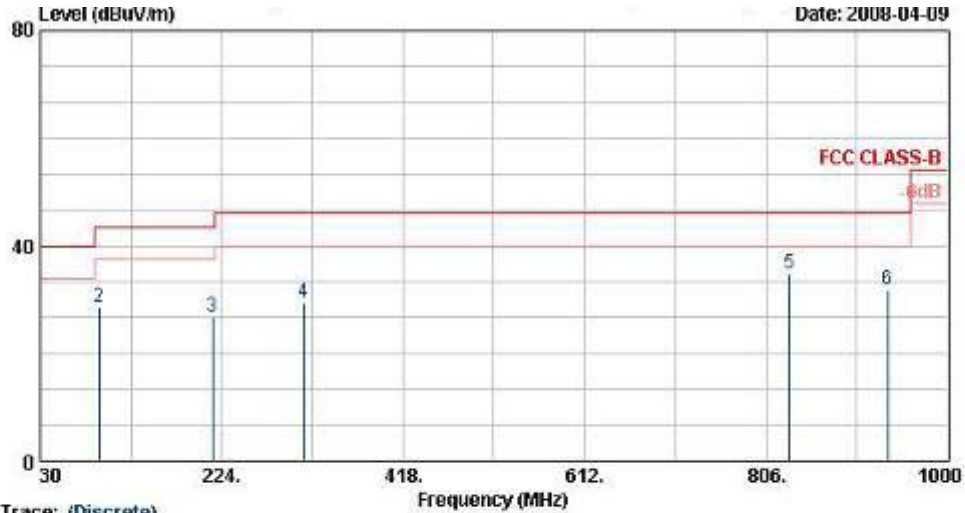

Site:
Condition:
EUT:
Power:
Model:
Mode:
Plane:

Trace: (Discrete)
03CH06-WV
FCC CLASS-B 3m LP-ANT(851121) VERTICAL
MC5574 EMI FCC submit with ID 2D Scanner
and w/ camera w/o camera
120Vac/60Hz
FR 840317
11g Tx_Ch01 , 2412MHz + Adaptor
H

	Freq	Level	Over	Limit	ReadAntenna	Cable	Preamp	Ant	Table	Remark
	MHz	dBuV/m	Limit	Line	Level	Loss	Factor	Pos	Pos	
			dB	dBuV/m	dBuV	dB	dB	cn	deg	
1	30.00	21.46	-18.54	40.00	35.00	19.66	0.30	33.50	---	Peak
2	92.64	28.42	-15.08	43.50	51.64	9.62	0.50	33.33	---	Peak
3	214.14	26.88	-16.62	43.50	49.58	10.16	0.64	33.50	---	Peak
4	311.90	29.48	-16.52	46.00	48.45	13.53	0.80	33.30	---	Peak
5	831.30	34.73	-11.27	46.00	46.13	20.04	1.20	32.63	100	251 Peak
6	936.30	31.88	-14.12	46.00	42.43	20.79	1.20	32.54	---	Peak

- Polarization : Vertical (1GHz-25GHz)

The test that passed at minimum margin was marked by the boldface in the following table.

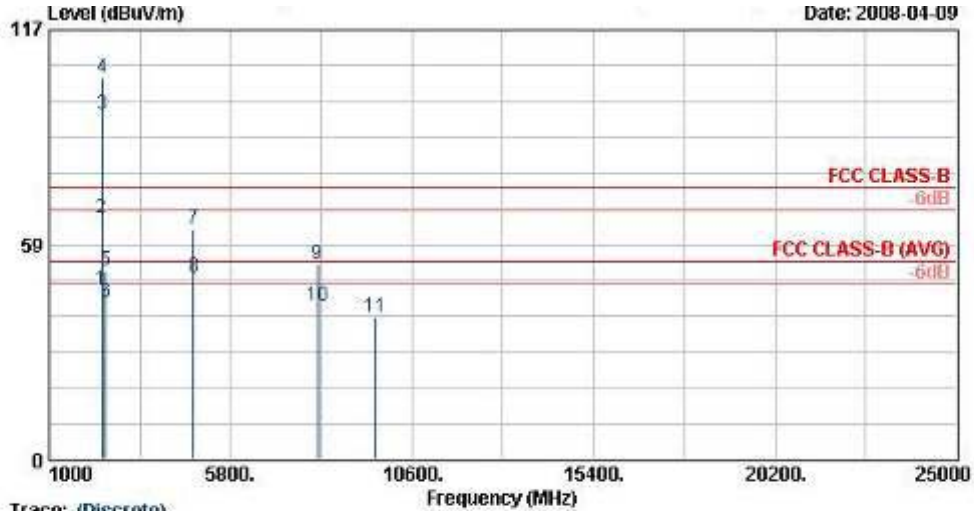

Site
Condition
EUT

Power
Model
Mode
Plane

Trace: (Discrete)
03CH06-RY
FCC CLASS-B 3m SHF-EHF HORN VERTICAL
MC5574 EMI FCC submit with ID 2D Scanner
and w/ camera w/o camera
120Vac/60Hz
FR 840317
11g Tx_Ch01 . 2412MHz + Adaptor

	Freq	Level	Over	Limit	Read	Antenna	Cable	Preamp	Ant	Table	Remark
	MHz	dBuV/m	Limit	Line	Level	Factor	Loss	Factor	Pos	Pos	
			dB	dBuV/m	dBuV	dB/m	dB	dB	cn	deg	
1 @	2389.61	46.03	-7.97	54.00	45.93	31.86	3.92	35.68	126	237	Average
2 @	2389.61	65.67	-8.33	74.00	65.57	31.86	3.92	35.68	100	0	Peak
3 @	2412.00	93.73			93.58	31.88	3.95	35.68	126	237	Average
4 @	2412.00	104.09			103.94	31.88	3.95	35.68	100	0	Peak
5	2486.00	51.35	-22.65	74.00	51.02	31.98	4.05	35.70	---	---	Peak
6	2486.00	42.81	-11.19	54.00	42.48	31.98	4.05	35.70	126	237	Average
7	4821.00	62.70	-11.30	74.00	58.47	34.13	5.77	35.67	100	0	Peak
8 @	4821.00	49.62	-4.38	54.00	45.39	34.13	5.77	35.67	100	68	Average
9	8097.00	52.96	-21.04	74.00	46.09	35.72	7.45	36.30	100	0	Peak
10	8097.00	41.93	-12.07	54.00	35.06	35.72	7.45	36.30	100	248	Average
11	9642.00	38.54	-35.46	74.00	77.42	-10.09	7.94	36.73	100	0	Peak

Remark: #3 and #4 are Fundamental Signals.

- Teat Model : Sample C
- Test Mode : Mode 5
- Polarization : Horizontal (30MHz-1GHz)

The test that passed at minimum margin was marked by the boldface in the following table.

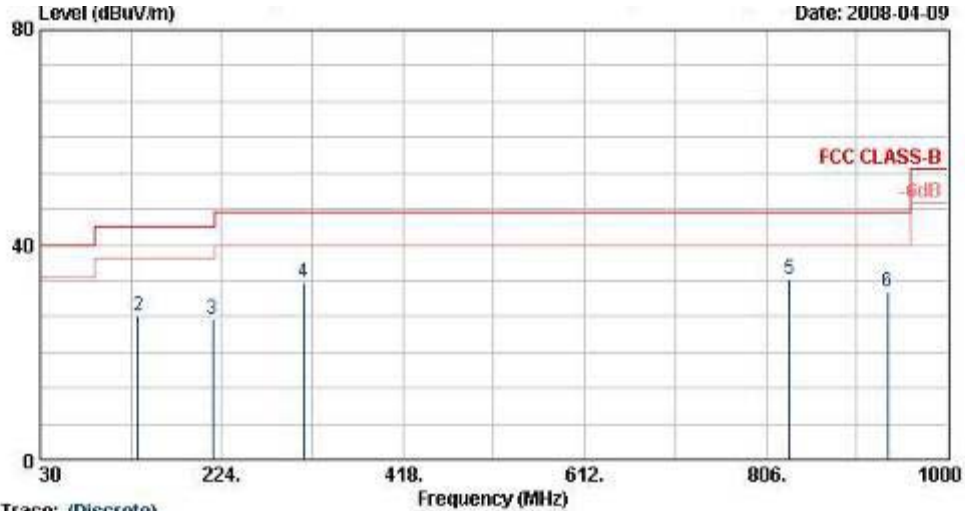

Site
Condition
EUT

Power
Model
Mode
Plane

Trace: (Discrete)
03CH06-RV
FCC CLASS-B 3m LF-ANT(951121) HORIZONTAL
MC5574 EMI FCC submit with ID 2D Scanner
and w/ camera w/o camera
120Vac/60Hz
FR 840317
11g Tx_Ch06 . 2437MHz + Adaptor
H

	Freq	Level	Over	Limit	ReadAntenna	Cable	Preamp	Ant	Table	Remark
	MHz	dBuV/m	Limit	Line	Level	Loss	Factor	Pos	Pos	
			dB	dBuV/m	dBuV	dB	dB	cn	deg	
1	30.00	23.26	-16.74	40.00	36.80	19.66	0.30	33.50	---	Peak
2	134.49	26.65	-16.85	43.50	48.52	11.05	0.50	33.43	---	Peak
3	214.14	26.30	-17.20	43.50	49.00	10.16	0.64	33.50	---	Peak
4	311.90	33.09	-12.91	46.00	52.06	13.53	0.80	33.30	---	Peak
5 @	831.30	33.52	-12.48	46.00	44.92	20.04	1.20	32.63	100	193 Peak
6	936.30	31.20	-14.80	46.00	41.76	20.79	1.20	32.54	---	Peak

- Polarization : Horizontal (1GHz-25GHz)

The test that passed at minimum margin was marked by the boldface in the following table.

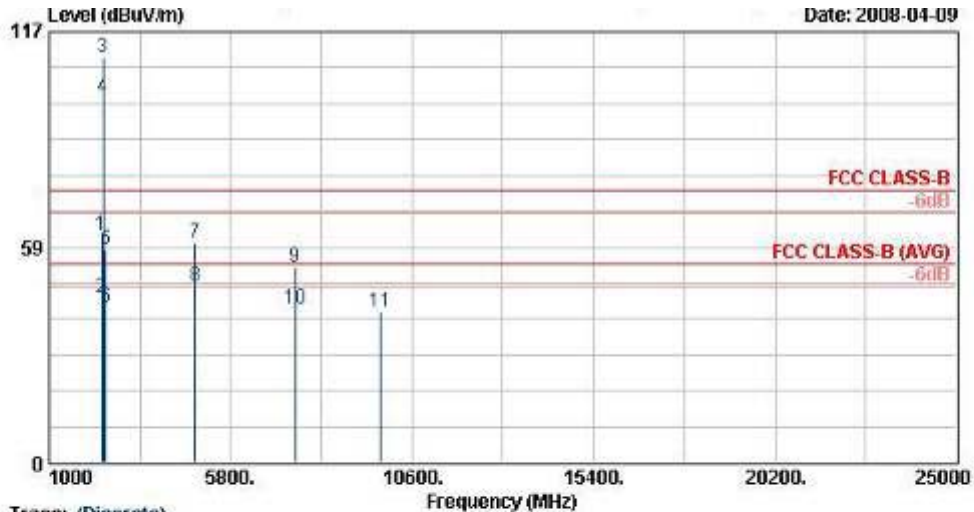

Site
Condition
EUT
Power
Model
Mode
Plane

Trace: (Discrete)
03CN06-WY
FCC CLASS-B 3m SHF-EHF HORN HORIZONTAL
MC5574 EYI FCC submit with ID 2D Scanner
and w/ camera w/o camera
120Vac/60Hz
FR 840317
11g Tx_Ch06 . 2437MHz + Adaptor
H

	Freq	Level	Over	Limit	Read	Antenna	Cable	Preamp	Ant	Table	Remark
	MHz	dBuV/m	Limit	Line	Level	Factor	Loss	Factor	Pos	Pos	
			dB	dBuV/m	dBuV	dB/n	dB	dB	cn	deg	
1 @	2390.00	61.65	-12.35	74.00	61.55	31.86	3.92	35.68	100	0	Peak
2 @	2390.00	44.64	-9.36	54.00	44.54	31.86	3.92	35.68	100	20	Average
3 @	2437.00	109.83			109.60	31.93	3.99	35.69	100	0	Peak
4 @	2437.00	99.25			99.02	31.93	3.99	35.69	100	20	Average
5	2483.50	57.82	-16.18	74.00	57.49	31.98	4.05	35.70	100	0	Peak
6 @	2483.50	41.98	-12.02	54.00	41.65	31.98	4.05	35.70	100	20	Average
7	4872.00	59.37	-14.63	74.00	55.07	34.15	5.80	35.65	100	0	Peak
8 @	4872.00	47.85	-6.15	54.00	43.55	34.15	5.80	35.65	100	324	Average
9	7506.00	52.99	-21.01	74.00	46.32	35.60	7.27	36.20	100	0	Peak
10 @	7506.00	41.81	-12.19	54.00	35.14	35.60	7.27	36.20	100	130	Average
11	9747.00	41.01	-32.99	74.00	79.63	-9.85	7.98	36.75	100	0	Peak

Remark: #3 and #4 are Fundamental Signals.

- Polarization : Vertical (30MHz-1GHz)

The test that passed at minimum margin was marked by the boldface in the following table.

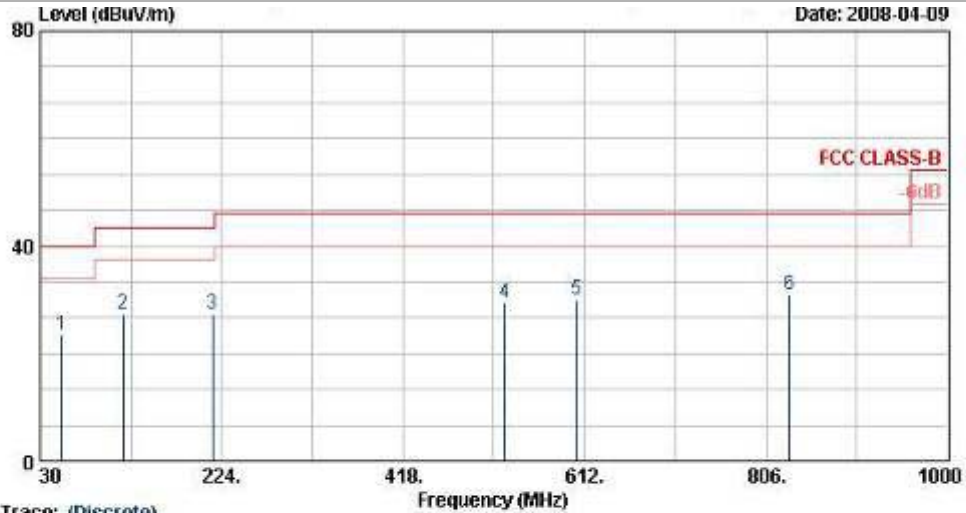

Trace: (Discrete)

Site
Condition
EUT
Power
Model
Mode
Plane

03CR06-RY
FCC CLASS-B 3m I/F-ANT(951121) VERTICAL
MC5574 EVI FCC submit with ID 2D Scanner
and w/ camera w/o camera
120Vac/60Hz
FR 840317
11g Tx_Ch06 , 2437MHz + Adaptor
H

	Freq	Level	Over	Limit	ReadAntenna	Cable	Preamp	Ant	Table	Remark
	MHz	dBUV/m	Limit	Line	Level	Loss	Factor	Pos	Pos	
			dB	dBUV/m	dBuV	dB	dB	cn	deg	
1	52.68	23.47	-16.53	40.00	48.58	7.79	0.34	33.24	---	Peak
2	118.29	27.49	-16.01	43.50	48.00	12.43	0.50	33.44	---	Peak
3	214.14	27.22	-16.28	43.50	49.92	10.16	0.64	33.50	---	Peak
4	526.80	29.57	-16.43	46.00	44.16	17.70	0.93	33.22	---	Peak
5	603.80	30.03	-15.97	46.00	43.42	18.49	1.00	32.87	---	Peak
6	831.30	31.07	-14.93	46.00	42.47	20.04	1.20	32.63	100	301 Peak

- Polarization : Vertical (1GHz-25GHz)

The test that passed at minimum margin was marked by the boldface in the following table.

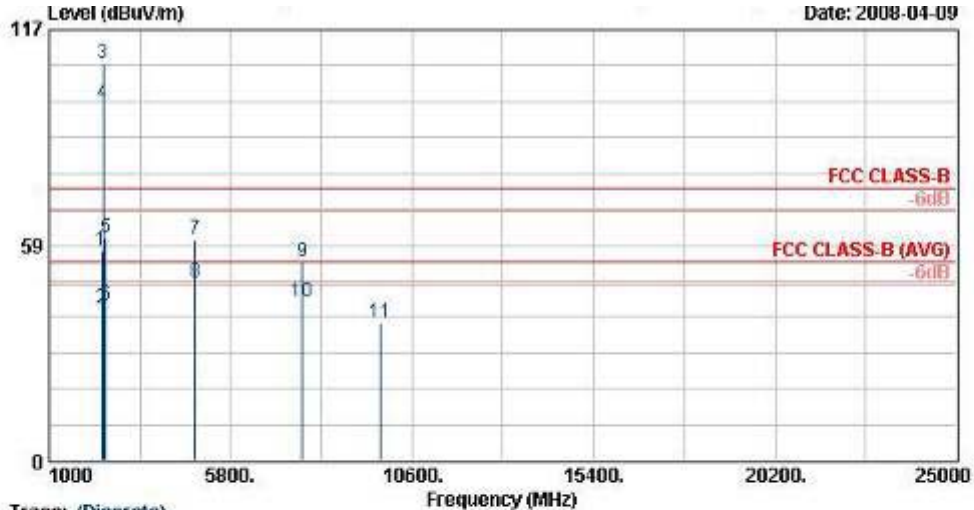

Site
Condition
EUT

Power
Model
Mode
Plane

Trace: (Discrete)
03CND6-WY
FCC CLASS-B 3m SHF-EHF HORN VERTICAL
MC5574 EMI FCC submit with ID 2D Scanner
and w/ camera w/o camera
120Vac/60Hz
FR 840317
11g Tx_Ch06 - 2437MHz + Adaptor
H

	Freq	Level	Over	Limit	Read	Antenna	Cable	Preamp	Ant	Table	Remark
	MHz	dBuV/m	Limit	Line	Level	Factor	Loss	Factor	Pos	Pos	
			dB	dBuV/m	dBuV	dB/n	dB	dB	cn	deg	
1	2390.00	57.07	-16.93	74.00	56.97	31.86	3.92	35.68	100	0	Peak
2	2390.00	41.52	-12.48	54.00	41.42	31.86	3.92	35.68	125	240	Average
3 @	2437.00	107.67			107.44	31.93	3.99	35.69	100	0	Peak
4 @	2437.00	96.96			96.73	31.93	3.99	35.69	125	240	Average
5	2484.00	60.39	-13.61	74.00	60.06	31.98	4.05	35.70	100	0	Peak
6 @	2484.00	42.37	-11.63	54.00	42.04	31.98	4.05	35.70	125	240	Average
7	4872.00	59.89	-14.11	74.00	55.59	34.15	5.80	35.65	100	0	Peak
8 @	4872.00	48.15	-5.85	54.00	43.85	34.15	5.80	35.65	100	71	Average
9	7692.00	53.77	-20.23	74.00	47.00	35.64	7.37	36.24	100	0	Peak
10 @	7692.00	43.20	-10.80	54.00	36.43	35.64	7.37	36.24	100	302	Average
11	9747.00	37.45	-36.55	74.00	76.06	-9.85	7.98	36.75	100	0	Peak

Remark: #3 and #4 are Fundamental Signals.

- Teat Model : Sample C
- Test Mode : Mode 6
- Polarization : Horizontal (30MHz-1GHz)

The test that passed at minimum margin was marked by the boldface in the following table.

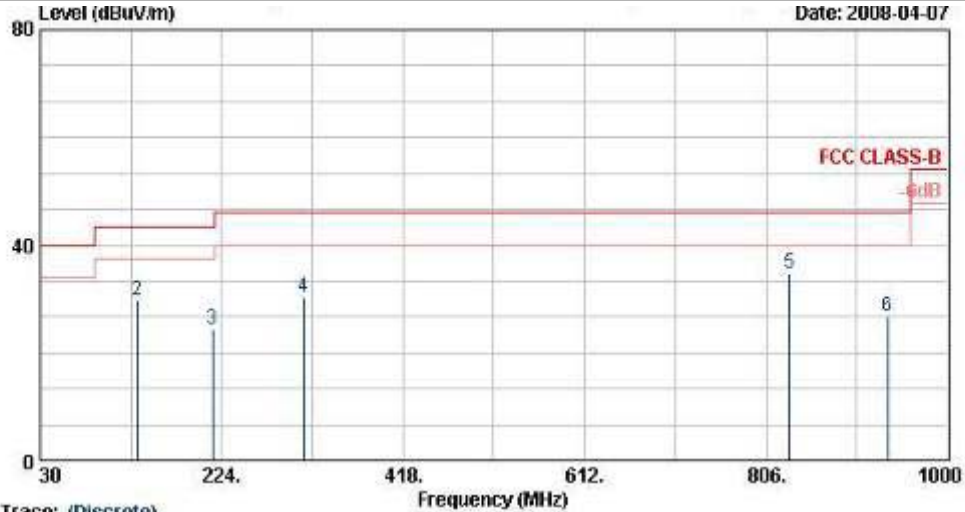

Site Condition EUT
Power Model Mode Plane

Trace: (Discrete)
03CH06-HY
FCC CLASS-B 3m LF-ANT(951121) HORIZONTAL
MC5574 EMI FCC submit with ID 2D Scanner
and w/ camera w/o camera
120Vac/60Hz
FR 840317
11g Tx_Ch11 . 2462MHz + Adaptor
H

	Freq	Level	Over	Limit	Read	Antenna	Cable	Preamp	Ant	Table	Remark
	MHz	dBuV/m	Limit	Line	Level	Factor	Loss	Factor	Pos	Pos	
			dB	dBuV/m	dBuV	dB/n	dB	dB	cn	deg	
1	30.54	21.88	-18.12	40.00	36.09	18.95	0.30	33.46	---	---	Peak
2	133.68	29.82	-13.68	43.50	51.50	11.21	0.50	33.40	---	---	Peak
3	214.14	24.24	-19.26	43.50	46.95	10.16	0.64	33.50	---	---	Peak
4	311.90	30.36	-15.64	46.00	49.33	13.53	0.80	33.30	---	---	Peak
5	831.30	34.65	-11.35	46.00	46.05	20.04	1.20	32.63	100	114	Peak
6	936.30	26.62	-19.38	46.00	37.17	20.79	1.20	32.54	---	---	Peak

- Polarization : Horizontal (1GHz-25GHz)

The test that passed at minimum margin was marked by the boldface in the following table.

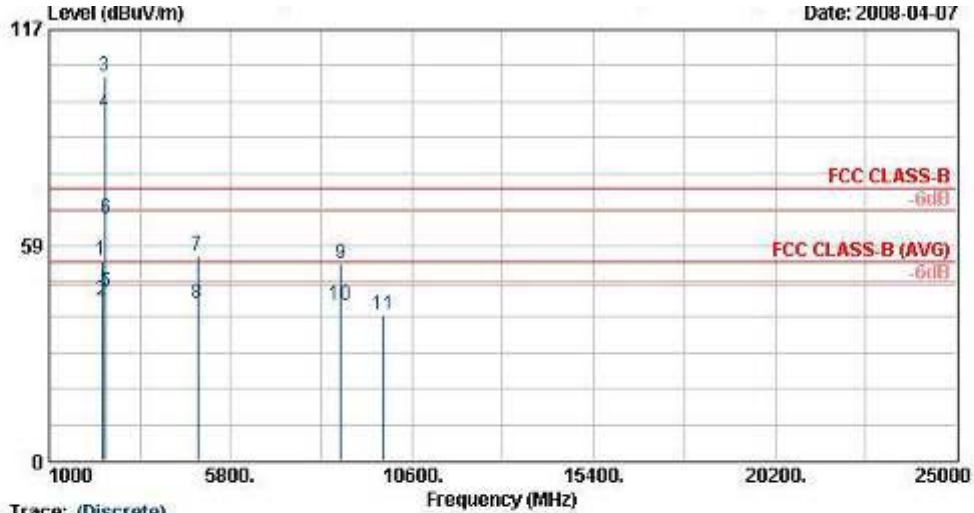

Site
Condition
EUT
Power
Model
Mode
Plane

Trace: (Discrete)
03CND6-WY
FCC CLASS-B 3m SHF-EHF HORN HORIZONTAL
MC5574 EYI FCC submit with ID 2D Scanner
and w/ camera w/o camera
120Vac/50Hz
FR 840317
11g Tx_Ch11 - 2462MHz - Adaptor
H

	Freq	Level	Over	Limit	Read	Antenna	Cable	Preamp	Ant	Table	Remark
	MHz	dBuV/m	Limit	Line	Level	Factor	Loss	Factor	Pos	Pos	
			dB	dBuV/m	dBuV	dB/n	dB	dB	cn	deg	
1	2382.00	54.31	-19.69	74.00	54.23	31.83	3.92	35.68	100	0	Peak
2	2382.00	43.46	-10.54	54.00	43.38	31.83	3.92	35.68	100	23	Average
3 X	2462.00	104.58			104.30	31.95	4.02	35.69	100	0	Peak
4 X	2462.00	94.42			94.14	31.95	4.02	35.69	100	23	Average
5	2483.50	45.77	-8.23	54.00	45.44	31.98	4.05	35.70	100	23	Average
6	2483.50	65.53	-8.47	74.00	65.20	31.98	4.05	35.70	100	0	Peak
7	4917.00	55.59	-18.41	74.00	51.22	34.17	5.83	35.63	100	0	Peak
8	4917.00	42.59	-11.41	54.00	38.22	34.17	5.83	35.63	100	326	Average
9	8712.00	53.39	-20.61	74.00	46.27	36.10	7.45	36.42	100	0	Peak
10	8712.00	42.25	-11.75	54.00	35.12	36.10	7.45	36.42	100	127	Average
11	9846.00	39.67	-34.33	74.00	78.03	-9.63	8.04	36.77	100	0	Peak

Remark: #3 and #4 are Fundamental Signals.

- Polarization : Vertical (30MHz-1GHz)

The test that passed at minimum margin was marked by the boldface in the following table.

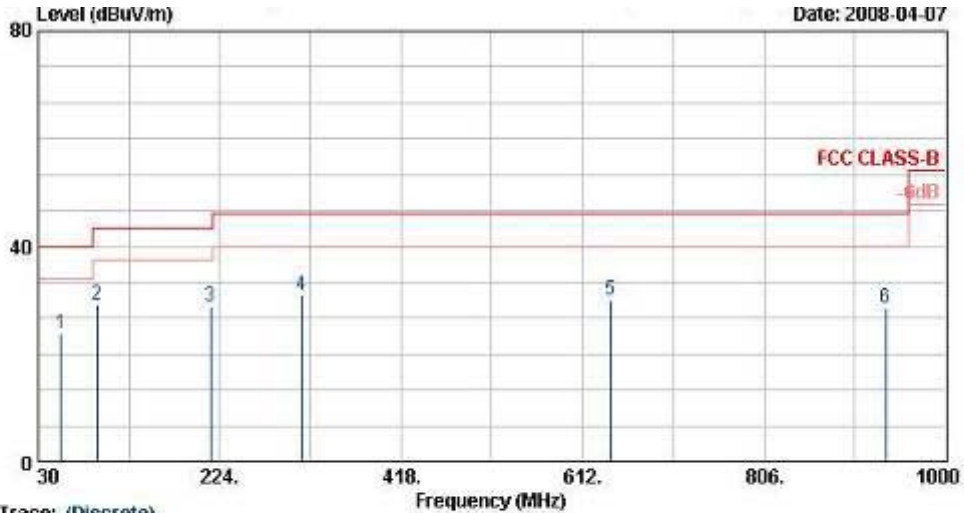

Site
Condition
EUT
Power
Model
Mode
Plane

Trace: (Discrete)
03CH06-RY
FCC CLASS-B 3m LF-ANT(951121) VERTICAL
MC5574 EMI FCC submit with ID 2D Scanner
and w/ camera w/o camera
120Vac/60Hz
FR 840317
11g Tx_Ch11 , 2462MHz + Adaptor
N

	Freq	Level	Over	Limit	Read	Antenna	Cable	Preamp	Ant	Table	Remark
	MHz	dBuV/m	Limit	Line	Level	Factor	Loss	Factor	Pos	Pos	
			dB	dBuV/m	dBuV	dB/n	dB	dB	cn	deg	
1	54.03	23.91	-16.09	40.00	49.36	7.50	0.38	33.33	---	---	Peak
2	92.64	29.05	-14.45	43.50	52.26	9.62	0.50	33.33	100	243	Peak
3	214.14	28.96	-14.54	43.50	51.66	10.16	0.64	33.50	---	---	Peak
4	311.90	30.87	-15.13	46.00	49.84	13.53	0.80	33.30	---	---	Peak
5	642.30	29.91	-16.09	46.00	43.15	18.65	1.10	32.99	---	---	Peak
6	936.30	28.64	-17.36	46.00	39.20	20.79	1.20	32.54	---	---	Peak

- Polarization : Vertical (1GHz-25GHz)

The test that passed at minimum margin was marked by the boldface in the following table.

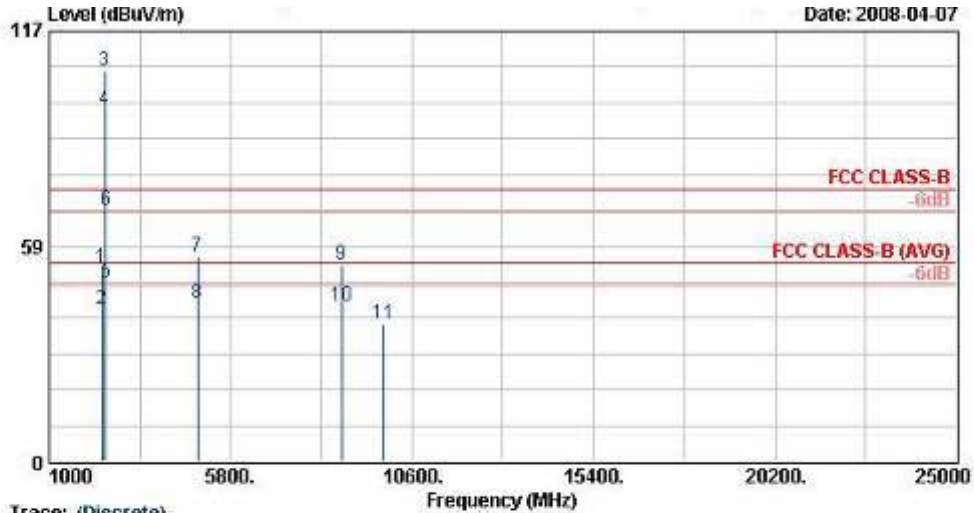

Site
Condition
EUT
Power
Model
Mode
Plane

Trace: (Discrete)
03C806-RY
FCC CLASS-B 3m SHF-EHF HORN VERTICAL
MC5574 EMI FCC submit with ID 2D Scanner
and w/ camera w/o camera
120Vac/60Hz
FR 840317
11g Tx_Ch11 . 2462MHz + Adaptor
H

	Freq	Level	Over	Limit	Read	Antenna	Cable	Preamp	Ant	Table	Remark
	MHz	dBuV/m	Limit	Line	Level	Factor	Loss	Factor	Pos	Pos	
			dB	dBuV/m	dBuV	dB/m	dB	dB	cn	deg	
1	2382.00	52.66	-21.34	74.00	52.59	31.83	3.92	35.68	100	0	Peak
2	2382.00	41.17	-12.83	54.00	41.09	31.83	3.92	35.68	131	78	Average
3 X	2462.00	106.11			105.83	31.95	4.02	35.69	100	0	Peak
4 @	2462.00	95.77			95.49	31.95	4.02	35.69	131	78	Average
5 !	2483.50	48.63	-5.37	54.00	48.30	31.98	4.05	35.70	131	78	Average
6 !	2483.50	68.17	-5.83	74.00	67.84	31.98	4.05	35.70	100	0	Peak
7	4917.00	55.67	-18.33	74.00	51.30	34.17	5.83	35.63	100	0	Peak
8	4917.00	42.86	-11.14	54.00	38.49	34.17	5.83	35.63	100	98	Average
9	8727.00	53.28	-20.72	74.00	46.12	36.13	7.48	36.44	100	0	Peak
10	8727.00	42.25	-11.75	54.00	35.08	36.13	7.48	36.44	100	113	Average
11	9846.00	37.29	-36.71	74.00	75.65	-9.63	8.04	36.77	100	0	Peak

Remark: #3 and #4 are Fundamental Signals.

- Test Model : Sample C
- Test Mode : Mode 7
- Polarization : Horizontal (30MHz-1GHz)

The test that passed at minimum margin was marked by the boldface in the following table.

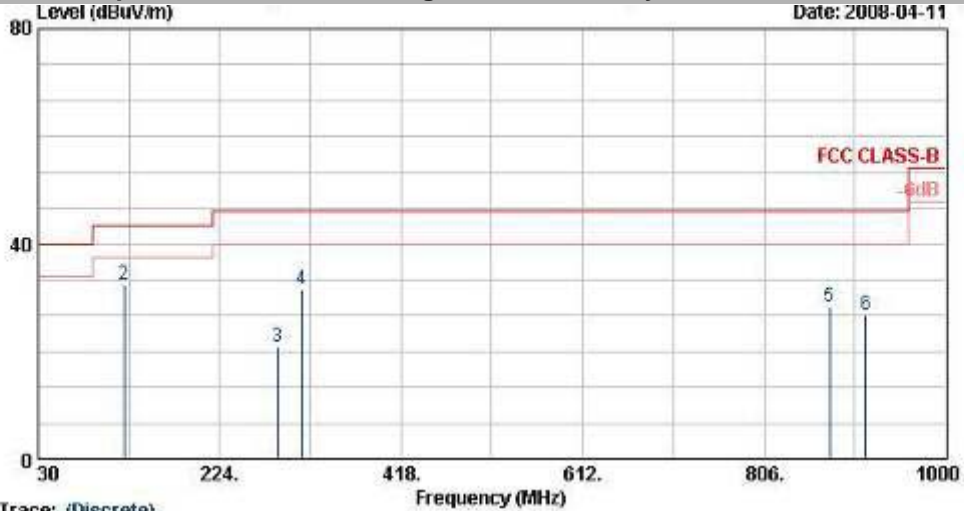

Site : 03C806-RY
 Condition : FCC CLASS-B 3m LF-ANT(951121) HORIZONTAL
 EUT : MC5574 EMI FCC submit with ID 2D Scanner and w/ camera w/o camera
 Power : 120Vac/50Hz
 Model : FR 840317
 Mode : 1lg Tx Ch01 : 2412MHz
 Plane : +BT_Tx Ch38_2441MHz + Adaptor
 H

Trace: (Discrete)

	Freq	Level	Over	Limit	Read	Antenna	Cable	Preamp	Ant	Table	Remark
	MHz	dBuV/m	Limit	Line	Level	Factor	Loss	Factor	Pos	Pos	
			dB	dBuV/m	dBuV	dB/m	dB	dB	cm	deg	
1	30.00	20.81	-19.19	40.00	34.35	19.66	0.30	33.50	---	---	Peak
2	121.53	32.27	-11.23	43.50	52.55	12.60	0.50	33.38	100	130	Peak
3	286.23	20.76	-25.24	46.00	40.48	12.95	0.70	33.37	---	---	Peak
4	311.90	31.60	-14.40	46.00	50.57	13.53	0.80	33.30	---	---	Peak
5	876.80	28.37	-17.63	46.00	39.45	20.36	1.30	32.74	---	---	Peak
6	915.30	26.67	-19.33	46.00	37.47	20.64	1.25	32.69	---	---	Peak

- Polarization : Horizontal (1GHz-25GHz)

The test that passed at minimum margin was marked by the boldface in the following table.

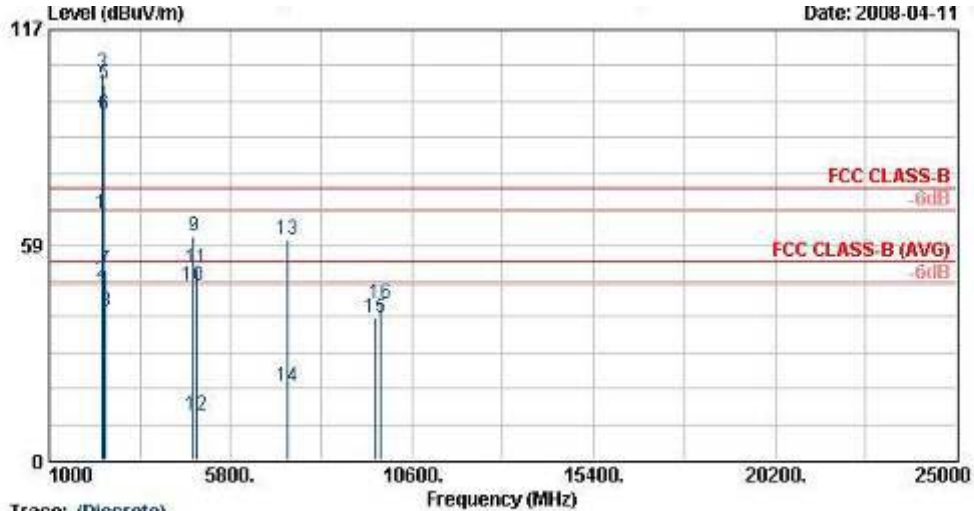

Site Condition EUT
Power Model Mode Plane

Trace: (Discrete)
03CH06-HY
FCC CLASS-B 3m SHF-EHF HORN HORIZONTAL
MC5574 EVI FCC submit with ID 2D Scanner and w/ camera w/o camera
120Vac/60Hz
FP 840317
11g Tx_Ch01 : 2412MHz
+BT_Tx_Ch30_2441MHz + Adaptor
H

	Freq	Level	Over Limit	Limit Line	ReadAntenna	Cable	Preamp	Ant	Table	Remark
	MHz	dBuV/m	dB	dBuV/m	dBuV	dB/n	dB	dB	cn	deg
1	2389.99	67.08	-6.92	74.00	66.98	31.86	3.92	35.68	100	0 Peak
2	2389.99	48.65	-5.35	54.00	48.55	31.86	3.92	35.68	140	20 Average
3	2412.00	105.07			104.92	31.88	3.95	35.68	100	0 Peak
4	2412.00	94.83			94.68	31.88	3.95	35.68	140	20 Average
5	2441.00	102.30			102.08	31.93	3.99	35.69	100	0 Peak
6	2441.00	94.15			93.93	31.93	3.99	35.69	122	332 Average
7	2483.85	51.85	-22.15	74.00	51.50	32.00	4.05	35.70	100	0 Peak
8	2483.85	40.37	-13.63	54.00	40.04	31.98	4.05	35.70	122	332 Average
9	4812.00	60.72	-13.28	74.00	58.51	34.12	5.77	35.68	100	0 Peak
10	4812.00	47.57	-6.43	54.00	43.36	34.12	5.77	35.68	100	117 Average
11	4881.00	52.37	-21.63	74.00	48.05	34.15	5.82	35.65	100	0 Peak
12	4881.00	12.37	-41.63	54.00	8.05	34.15	5.82	35.65	100	21 Average
13	7317.00	60.18	-13.82	74.00	53.44	35.67	7.20	36.13	100	0 Peak
14	7317.00	20.18	-33.82	54.00	13.44	35.67	7.20	36.13	100	160 Average
15	9651.00	38.74	-35.26	74.00	77.60	-10.07	7.94	36.73	100	0 Peak
16	9782.00	42.72	-31.28	74.00	81.30	-9.83	8.00	36.76	100	0 Peak

Remark: #3, #4, #5, and #6 are Fundamental Signals.

- Polarization : Vertical (30MHz-1GHz)

The test that passed at minimum margin was marked by the boldface in the following table.

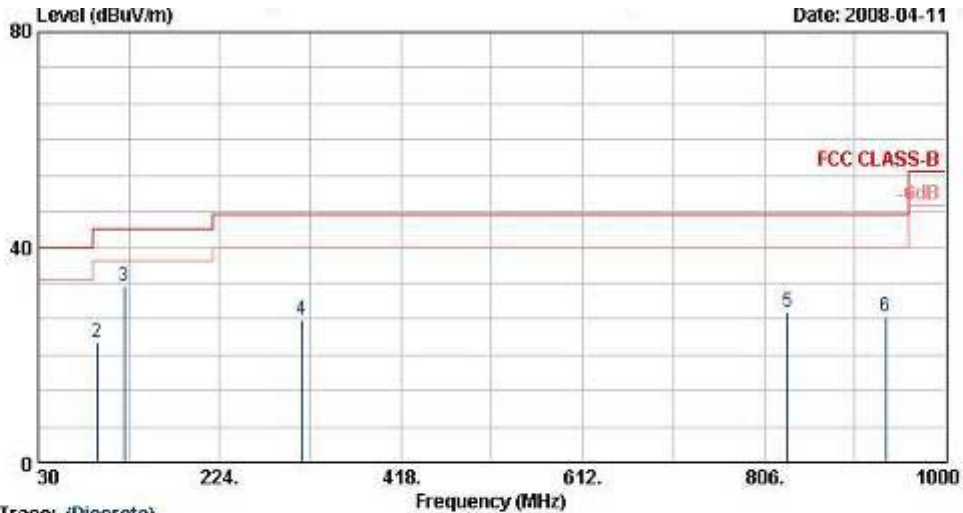

Site: 03CR06-RV
 Condition: FCC CLASS-B 3m LF-ANT(951121) VERTICAL
 EUT: MC5574 EVI FCC submit with ID 2D Scanner and w/ camera w/o camera
 Power: 120Vac/60Hz
 Model: FR 840317
 Mode: 11g Tx_Ch01 : 2412MHz
 Plane: +BT_Tx_Ch09_2441MHz + Adaptor

Trace: (Discrete)

	Freq	Level	Over	Limit	ReadAntenna	Cable	Preamp	Ant	Table	Remark
	MHz	dBuV/m	Limit	Line	Level	Loss	Factor	Pos	Pos	
			dB	dBuV/m	dBuV	dB	dB	cm	deg	
1	30.00	21.31	-18.69	40.00	34.85	19.66	0.30	33.50	---	Peak
2	92.84	22.45	-21.05	43.50	45.66	9.62	0.50	33.33	---	Peak
3	121.53	32.60	-10.90	43.50	52.88	12.60	0.50	33.38	100	244 Peak
4	311.90	26.46	-19.54	46.00	45.43	13.53	0.80	33.30	---	Peak
5	831.30	27.94	-18.06	46.00	39.33	20.04	1.20	32.63	---	Peak
6	936.30	27.17	-18.83	46.00	37.73	20.79	1.20	32.54	---	Peak

- Polarization : Vertical (1GHz-25GHz)

The test that passed at minimum margin was marked by the boldface in the following table.

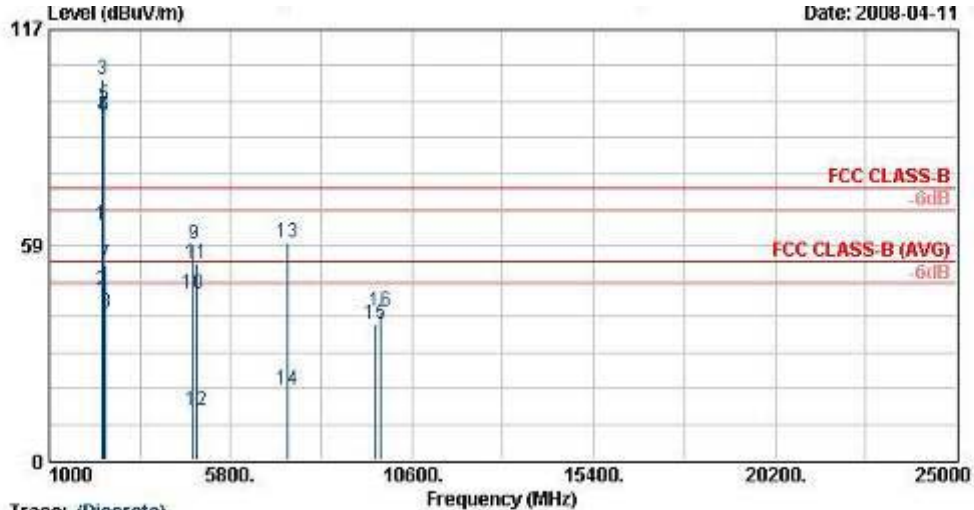

Site: 03CH06-HY
 Condition: FCC CLASS-B 3m SHF-EHF HORN VERTICAL
 EUT: MCS574 EMI FCC submit with ID 2D Scanner and w/ camera w/o camera
 Power: 120Vac/60Hz
 Model: FR 840317
 Mode: 11g Tx_Ch01 ; 2412MHz
 Plane: +BT_Tx_Ch08_2441MHz + Adaptor

	Freq	Level	Over	Limit	Read	Antenna	Cable	Preamp	Ant	Table	Remark
	MHz	dBuV/m	Limit	Line	Level	Factor	Loss	Factor	Pos	Pos	
			dB	dBuV/m	dBuV	dB/m	dB	dB	cm	deg	
1	2389.99	63.81	-10.19	74.00	63.71	31.86	3.92	35.68	100	0	Peak
2	2389.99	46.02	-7.98	54.00	45.92	31.86	3.92	35.68	123	33	Average
3 X	2412.00	103.71			103.56	31.88	3.95	35.68	100	0	Peak
4 X	2412.00	93.47			93.32	31.88	3.95	35.68	123	33	Average
5 X	2441.00	96.41			96.18	31.93	3.99	35.69	100	0	Peak
6 @	2441.00	93.49			93.27	31.93	3.99	35.69	100	233	Average
7	2499.81	52.97	-21.03	74.00	52.64	31.98	4.05	35.70	100	0	Peak
8	2499.81	40.01	-13.99	54.00	39.66	32.00	4.05	35.70	123	33	Average
9	4821.00	58.77	-15.23	74.00	54.54	34.13	5.77	35.67	100	0	Peak
10	4821.00	45.12	-8.88	54.00	40.89	34.13	5.77	35.67	100	179	Average
11	4881.00	53.30	-20.70	74.00	48.98	34.15	5.82	35.65	100	0	Peak
12	4881.00	13.30	-40.70	54.00	8.98	34.15	5.82	35.65	100	5	Average
13	7326.00	59.17	-14.83	74.00	52.42	35.67	7.21	36.13	100	0	Peak
14	7326.00	19.17	-34.83	54.00	12.42	35.67	7.21	36.13	100	321	Average
15	9651.00	36.97	-37.03	74.00	75.83	-10.07	7.94	36.73	100	0	Peak
16	9762.00	40.64	-33.36	74.00	79.23	-9.83	8.00	36.76	100	0	Peak

Remark: #3, #4, #5, and #6 are Fundamental Signals.

5.8 Antenna Requirements

5.8.1 Standard Applicable

For intentional device, according to FCC 47 CFR Section 15.203, an intentional radiator shall be designed to ensure that no other antenna except assembled by the responsible party shall be used with the device.

And according to FCC 47 CFR Section 15.247 (b), if directional gain of transmitting antennas is greater than 6dBi, the power shall be reduced by the same level in dB comparing to gain minus 6dBi.

5.8.2 Antenna Connected Construction

The antenna used in this product is PIFA Antenna for WLAN without connector and it is considered to meet antenna requirement of FCC.

5.8.3 Antenna Gain

The antenna gain of EUT is less than 6 dBi. Therefore, it is not necessary to reduce maximum peak output power limit.

6. List of Measuring Equipments

Instrument	Manufacturer	Model No.	Serial No.	Characteristics	Calibration Date	Due Date	Remark
EMC Receiver	R&S	ESCS 30	100132	9kHz – 2.75GHz	Jul. 14, 2007	Jul. 13, 2008	Conduction (CO01-HY)
LISN	MessTec	NNB-2/16Z	2001/004	9kHz – 30MHz	Mar. 24, 2008	Mar. 23, 2009	Conduction (CO01-HY)
LISN (Support Unit)	MessTec	NNB-2/16Z	2001/009	9kHz – 30MHz	Mar. 13, 2008	Mar. 12, 2009	Conduction (CO01-HY)
EMI Filter	LINDGREN	LRE-2060	1004	< 450Hz	N/A	N/A	Conduction (CO01-HY)
EMI Filter	LINDGREN	N6006	201052	0 – 60Hz	N/A	N/A	Conduction (CO01-HY)
RF Cable-CON	Suhner Switzerland	RG223/U	CB029	9kHz – 30MHz	Dec. 03, 2007	Dec. 02, 2008	Conduction (CO01-HY)
Isolation Transformer	Erika Fiedler OHG	D-65396 Walluf	58	45MHz-2.15GHz	N/A	N/A	Conduction (CO01-HY)
Impedance Stabilization	SCHAFFNER	ST08	22589	150kHz – 230MHz	Mar. 03, 2008	Feb. 14, 2009	Conduction (CO01-HY)
Impedance Stabilization	SCHAFFNER	T400	21653	150kHz – 230MHz	May. 09, 2007	May 08, 2008	Conduction (CO01-HY)
Impedance Stabilization	SCHAFFNER	T800	23342	150kHz – 230MHz	Mar. 03, 2008	Mar. 04, 2009	Conduction (CO01-HY)
Spectrum Analyzer	Agilent	E4408B	MY44211028	9KHz-26.5GHz	Oct. 17, 2007	Oct. 16, 2008	Radiation (03CH06-HY)
EMI Test Receiver	R&S	ESCS30	100356	9KHz-2.75GHz	Jul. 26, 2007	Jul. 25, 2008	Radiation (03CH06-HY)
Bilog Antenna	SCHAFFNER	CBL6112B	2885	30MHz -2GHz	Dec. 01, 2007	Nov. 30, 2008	Radiation (03CH06-HY)
Double Ridge Horn Antenna	Com-Power	AH118	071025	1G~18G	Jun. 04, 2007	Jun. 03, 2008	Radiation (03CH06-HY)
SHF-EHF Horn	SCHWARZBECK	BBHA 9170	9170-251	14G - 40G	Oct. 17, 2007	Oct. 16, 2008	Radiation (03CH06-HY)
Pre Amplifier	Agilent	8449B	3008A01917	1G - 26.5G	Nov. 22, 2007	Nov. 21, 2008	Radiation (03CH06-HY)
Pre Amplifier	EMEC	PA303	PA303-SMA-059	100K~3GHz	Nov. 26, 2007	Nov. 25, 2008	Radiation (03CH06-HY)
Base Station Simulator	R & S	CMU200	103937	WWAN	Oct. 19, 2007	Oct. 18, 2008	Radiation (03CH06-HY)

7. Uncertainty Evaluation

Uncertainty of Conducted Emission Measurement (150 KHz ~ 30 MHz)

Contribution	Uncertainty of x_i		$u(x_i)$
	dB	Probability Distribution	
Receiver reading	0.10	Normal(k=2)	0.05
Cable loss	0.10	Normal(k=2)	0.05
AMN insertion loss	2.50	Rectangular	0.63
Receiver Spec	1.50	Rectangular	0.43
Site imperfection	1.39	Rectangular	0.80
Mismatch	+0.34/-0.35	U-shape	0.24
Combined standard uncertainty Uc(y)	1.13		
Measuring uncertainty for a level of confidence of 95% U=2Uc(y)	2.26		

Uncertainty of Radiated Emission Measurement (30 MHz ~ 1000 MHz)

Contribution	Uncertainty of x_i		$u(x_i)$
	dB	Probability Distribution	
Receiver reading	0.11	Normal(k=2)	0.06
Antenna factor calibration	0.91	Normal(k=2)	0.46
Cable loss calibration	0.12	Normal(k=2)	0.06
Pre Amplifier Gain calibration	0.15	Normal(k=2)	0.08
RCV/SPA specification	2.50	Rectangular	0.72
Antenna Factor Interpolation for Frequency	1.00	Rectangular	0.29
Site imperfection	1.52	Rectangular	0.88
Mismatch	+0.45/-0.48	U-shaped	0.33
Combined standard uncertainty Uc(y)	1.30		
Measuring uncertainty for a level of confidence of 95% U=2Uc(y)	2.60		

Uncertainty of Radiated Emission Measurement (1 GHz ~ 40 GHz)

Contribution	Uncertainty of x_i		$u(x_i)$	C_i	$C_i * u(x_i)$
	dB	Probability Distribution			
Receiver reading	±0.10	Normal(k=1)	0.10	1	0.10
Antenna factor calibration	±1.70	Normal(k=2)	0.85	1	0.85
Cable loss calibration	±0.50	Normal(k=2)	0.25	1	0.25
Receiver Correction	±2.00	Rectangular	1.15	1	1.15
Antenna Factor Directional	±1.50	Rectangular	0.87	1	0.87
Site imperfection	±2.80	Triangular	1.14	1	1.14
Mismatch Receiver VSWR $\Gamma_1 = 0.197$ Antenna VSWR $\Gamma_2 = 0.194$ Uncertainty = $20 \log(1 - \Gamma_1 * \Gamma_2 * \Gamma_3)$	+0.34/-0.35	U-shaped	0.244	1	0.244
Combined standard uncertainty $U_c(y)$	2.36				
Measuring uncertainty for a level of confidence of 95% $U = 2U_c(y)$	4.72				

The measured result is : y dBuV \pm U dB
for a level of confidence of approximately 95% , ($k = 2$)