

FCC Test Report

EQUIPMENT : EDA (Enterprise Digital Assistant)
BRAND NAME : Symbol
MODEL NAME : MC5504
FCC ID : H9PMC5504
STANDARD : FCC Part 15 Subpart C §15.247
CLASSIFICATION : Digital Spread Spectrum (DSS)
APPLICANT : Symbol Technologies Inc

One Symbol Plaza Holtsville, NY 11742-1300 USA

The product sample received on Oct. 29, 2008 and completely tested on Nov. 19, 2008. We, SPORTON INTERNATIONAL INC., would like to declare that the tested sample has been evaluated in accordance with the procedures given in ANSI C63.4-2003 and shown compliance with the applicable technical standards.

The test results in this report apply exclusively to the tested model / sample. Without written approval of SPORTON INTERNATIONAL INC., the test report shall not be reproduced except in full.

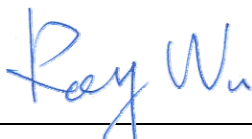

Reviewed by: Roy Wu / Manager



SPORTON INTERNATIONAL INC.

No. 52, Hwa Ya 1st Rd., Hwa Ya Technology Park, Kwei-Shan Hsiang, Tao Yuan Hsien, Taiwan, R.O.C.



TABLE OF CONTENTS

SUMMARY OF TEST RESULT 3

REVISION HISTORY..... 4

1 GENERAL DESCRIPTION..... 5

 1.1 Applicant 5

 1.2 Manufacturer..... 5

 1.3 Feature of Equipment Under Test 5

 1.4 Testing Site 7

 1.5 Applied Standards 7

 1.6 Ancillary Equipment List 7

2 TEST CONFIGURATION OF EQUIPMENT UNDER TEST..... 8

 2.1 Pre-Scanned RF Power 8

 2.2 Test Mode 9

 2.3 Connection Diagram of Test System..... 10

 2.4 RF Utility 10

3 NUMBER OF CHANNEL MEASUREMENT 11

 3.2 20dB Bandwidth Measurement 15

 3.3 Hopping Channel Separation Measurement 22

 3.4 Dwell Time Measurement 29

 3.5 Peak Output Power Measurement 42

 3.6 Band Edges Measurement 51

 3.7 AC Conducted Emission Measurement..... 59

 3.8 Radiated Emission Measurement..... 65

 3.9 Antenna Requirements 83

4 LIST OF MEASURING EQUIPMENTS 84

5 UNCERTAINTY OF EVALUATION..... 85

6 CERTIFICATION OF TAF ACCREDITATION 87

APPENDIX A. PHOTOGRAPHS OF EUT

APPENDIX B. SETUP PHOTOGRAPHS



SUMMARY OF TEST RESULT

Report Section	FCC Rule	IC Rule	Description	Limit	Result	Remark
3.1	15.247(b)(1)	A8.4(2)	Number of Channels	≥ 15Chs	Pass	
3.2	15.247(a)(1)	A8.1(a)	20dB Bandwidth	NA	Pass	-
3.3	15.247(a)(1)	A8.1(b)	Channel Separation	≥ 2/3 of 20dB BW	Pass	-
3.4	15.247(a)(1)	A8.1(d)	Dwell Time of Each Channel	≤ 0.4sec in 31.6sec period	Pass	-
3.5	15.247(a)(1)	A8.1(b)	Peak Output Power	≤ 0.125W	Pass	-
3.6	15.247(d)	A8.5	Frequency Band Edges	≤ 20dBc	Pass	-
3.7	15.207	Gen 7.2.2	AC Conducted Emission	15.207(a)	Pass	Under limit 11.8 dB at 0.446 MHz
3.8	15.247(d)	A8.5	Transmitter Radiated Emission	15.209(a) & 15.247(d)	Pass	Under limit 6.53 dB at 32.16 MHz
3.9	15.203 & 15.247(b)	A8.4	Antenna Requirement	N/A	Pass	-



REVISION HISTORY

REPORT NO.	VERSION	DESCRIPTION	ISSUED DATE
FR8O2928	Rev. 01	Initial issue of report	Dec. 01, 2008



1 General Description

1.1 Applicant

Symbol Technologies Inc
One Symbol Plaza Holtsville, NY 11742-1300 USA

1.2 Manufacturer

Symbol Technologies Inc
One Symbol Plaza Holtsville, NY 11742-1300 USA

1.3 Feature of Equipment Under Test

Product Feature & Specification	
Equipment	EDA (Enterprise Digital Assistant)
Brand Name	Symbol
Model Name	MC5504
Sample 1	1D Scanner + Numeric Keypad
Sample 2	2D Scanner + Qwerty Keypad
Tx/Rx Frequency Range	2400 MHz ~ 2483.5 MHz
Number of Channels	79
Carrier Frequency of Each Channel	2402+n*1 MHz; n=0~78
Channel Spacing	1 MHz
Maximum Output Power to Antenna	Bluetooth : 2.49 dBm (1Mbps) Bluetooth EDR : 4.20dBm (2Mbps) / 4.67dBm (3Mbps)
Antenna Type	PIFA Antenna with gain 0.43 dBi
Antenna Connector Type	N/A
HW Version	DV
SW Version	BSP25
Type of Modulation	Bluetooth (1Mbps) : GFSK Bluetooth EDR (2Mbps) : $\pi/4$ -DQPSK Bluetooth EDR (3Mbps) : 8-DPSK
EUT Stage	Identical Prototype

Accessories List:

Component Model		
AC Adapter	Brand Name	Motorola
	Model Name	EADP-16BBA
	Power Rating	I/P: 100-240Vac, 50-60Hz, 0.4A O/P: 5.4Vdc, 3A
	DC Power Cord Type	1.94 meter shielded cable without ferrite core
Power Cable	AC Power Cord Type	1.82 meter without shielded cable without ferrite core
Battery 1	Brand Name	Motorola
	Model Name	82-107172-01
	Power Rating	3.7Vdc, 2400mAh
	Type	Li-ion
Battery 2	Brand Name	Motorola
	Model Name	82-111094-01
	Power Rating	3.7Vdc, 3600mAh
	Type	Li-ion
USB Cable	Brand Name	Motorola
	Part Number	25-108022-01R
	Signal Line Type	1.62 meter shielded cable with ferrite core
Holster 1	Brand Name	Symbol
	Part Number	11-57530-02
Holster 2	Brand Name	Symbol
	Part Number	21-67292-01R
Holster 3	Brand Name	Symbol
	Part Number	SG-MC5521110-01R

Remark:

1. The above EUT's information was declared by manufacturer. Please refer to the specifications or user's manual for more detailed description.
2. For accessories equipped with this EUT, please refer to the appendix of the external photo.

1.4 Testing Site

Test Site	SPORTON INTERNATIONAL INC.		
Test Site Location	No. 52, Hwa Ya 1 st Rd., Hwa Ya Technology Park, Kwei-Shan Hsiang, Tao Yuan Hsien, Taiwan, R.O.C TEL: +886-3-3273456 / FAX: +886-3-3284978		
Test Site No.	Sporton Site No.		FCC/IC Registration No.
	CO05-HY	03CH06-HY	TW1022/4086B-1

1.5 Applied Standards

According to the specifications of the manufacturer, the EUT must comply with the requirements of the following standards:

- ♦ FCC Part 15 Subpart C §15.247
- ♦ FCC Public Notice DA 00-705
- ♦ ANSI C63.4-2003
- ♦ IC RSS-210 Issue 7

Remark:

1. All test items were verified and recorded according to the standards and without any deviation during the test.
2. This EUT has also been tested and complied with the requirements of FCC Part 15, Subpart B (DoC), recorded in a separate test report.

1.6 Ancillary Equipment List

Item	Equipment	Trade Name	Model Name	FCC ID	Data Cable	Power Cord
1.	Base Station	R&S	CMU 200	N/A	N/A	Unshielded, 1.8 m
2.	GPS Station	T&E	GS-50	N/A	N/A	Unshielded, 1.8 m
3.	BT Base Station	Anritsu	8852B	N/A	N/A	Unshielded, 1.8 m
4.	Notebook	DELL	D400	E2K24GBRL	N/A	AC I/P: Unshielded, 1.2 m DC O/P: Shielded, 1.8 m
5.	Bluetooth Earphone	Engotech	ET-BH111	PQY471087	N/A	N/A
6.	RS-232 Mouse	State	MS-303	FCC DoC	Unshielded, 1.2 m	N/A
7.	i-pod	Apple	A1199	N/A	Unshielded, 1.2 m	N/A

2 Test Configuration of Equipment Under Test

2.1 Pre-Scanned RF Power

Preliminary tests were performed in different data rate and recorded the RF output power in the following table:

RF Output Power				
Channel	Frequency	Data Rate / Modulation		
		GFSK	$\pi/4$ -DQPSK	8-DPSK
		1Mbps	2Mbps	3Mbps
Ch00	2402MHz	2.49 dBm	4.20 dBm	4.67 dBm
Ch39	2441MHz	2.31 dBm	3.57 dBm	3.81 dBm
Ch78	2480MHz	1.35 dBm	2.26 dBm	2.45 dBm

Remark:

1. The EUT is programmed to transmit signal continuously for all testing.

2.2 Test Mode

The EUT has been associated with peripherals pursuant to ANSI C63.4-2003 and configuration operated in a manner tended to maximize its emission characteristics in a typical application. Frequency range investigated: conduction (150 kHz to 30 MHz), radiation (9 kHz to the 10th harmonic of the highest fundamental frequency or to 40 GHz, whichever is lower). Pre-scanned tests were conducted to determine the final configuration from all possible combinations. The following tables are showing the test modes as the worst cases and recorded in this report.

Test Cases			
Test Item	Modulation		
	GFSK/1Mbps	$\pi/4$ -DQPSK/2Mbps	8-DPSK/3Mbps
Conducted TCs	<ul style="list-style-type: none"> ■ Mode 1: CH00_2402 MHz ■ Mode 2: CH39_2441 MHz ■ Mode 3: CH78_2480 MHz 	<ul style="list-style-type: none"> ■ Mode 4: CH00_2402 MHz ■ Mode 5: CH39_2441 MHz ■ Mode 6: CH78_2480 MHz 	<ul style="list-style-type: none"> ■ Mode 7: CH00_2402 MHz ■ Mode 8: CH39_2441 MHz ■ Mode 9: CH78_2480 MHz
Radiated TCs	N/A	N/A	<ul style="list-style-type: none"> ■ Mode 1: CH00_2402 MHz (1D Scanner + Numeric Keypad + Battery 2 <3600mAh>) ■ Mode 2: CH39_2441 MHz (1D Scanner + Numeric Keypad + Battery 2 <3600mAh>) ■ Mode 3: CH78_2480 MHz (1D Scanner + Numeric Keypad + Battery 2 <3600mAh>) ■ Mode 4: CH00_2402 MHz (2D Scanner + Qwerty Keypad + Battery 2 <3600mAh>) ■ Mode 5: CH78_2480 MHz (2D Scanner + Qwerty Keypad + Battery 2 <3600mAh>)
AC Conducted Emission	Mode 1 : GSM850 Idle + GPS Rx + BT Link + USB Charging Cable with AC power + USB Link + MPEG4 + 1D Scanner + Numeric Keypad + Battery 2 (3600mAh) Mode 2 : GSM850 Idle + GPS Rx + BT Link + USB Charging Cable with AC power + USB Link + Camera + 2D Scanner + Qwerty Keypad + Battery 1 (2400mAh)		
Remark: 1. The worst cases of radiated emission were Bluetooth EDR 3Mbps link modes; only the test data of these modes was reported. 2. For radiation emission mode 4 and 5, only band edge was verified.			

2.3 Connection Diagram of Test System

<Conducted Emission>

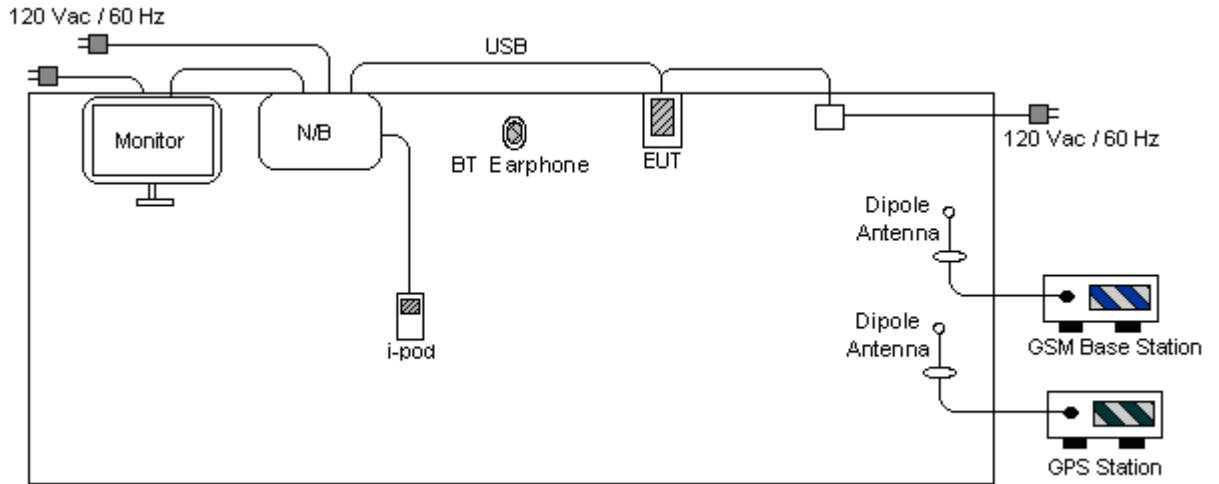

<Radiated Emission>

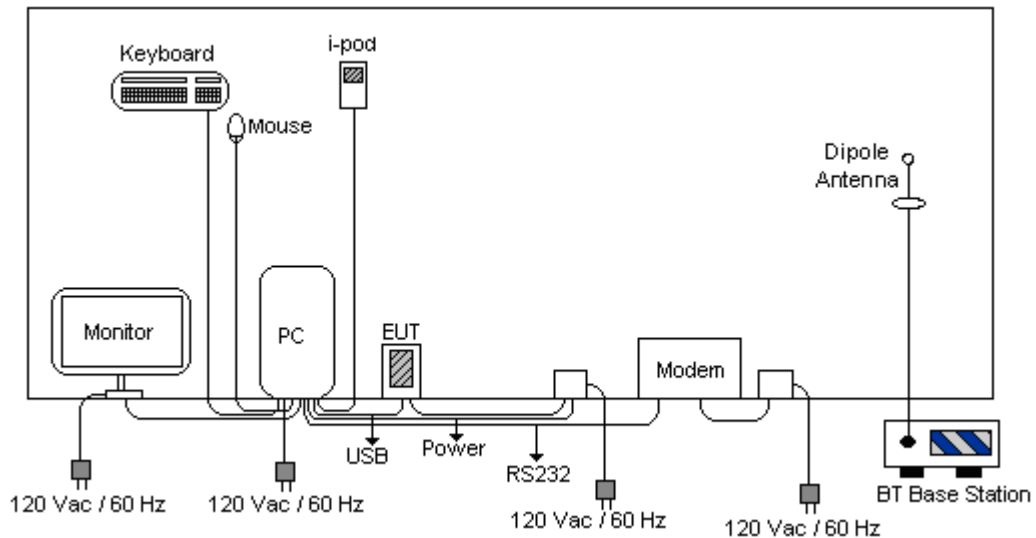

2.4 RF Utility

For Bluetooth function, the RF Utility, "BTRegTest_ver3.5" was installed in EUT, which was programmed to link with BT base station in engineering mode.

3 Number of Channel Measurement

3.1.1 Limits of Number of Hopping Frequency

Frequency hopping systems in the 2400-2483.5 MHz band shall use at least 15 channels.

3.1.2 Measuring Instruments

See list of measuring instruments of this test report.

3.1.3 Test Procedure

1. The testing follows FCC Public Notice DA 00-705 Measurement Guidelines.
2. The RF output of EUT was connected to the spectrum analyzer by a low loss cable.
3. The modulation types of EUT are irrelevant to number of hopping channels deviation.
4. The EUT must have its hopping function enabled. Use the following spectrum analyzer settings:
Span = the frequency band of operation; RBW \geq 1% of the span; VBW \geq RBW; Sweep = auto;
Detector function = peak; Trace = max hold.
5. The number of hopping frequency used is defined as the device has the numbers of total channel.

3.1.4 Test Setup

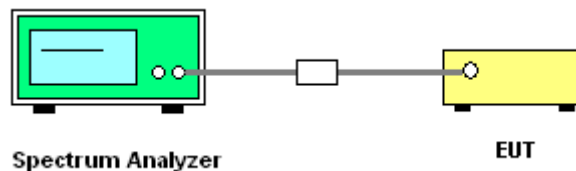

3.1.5 Test Result of Number of Hopping Frequency

Test Mode :	Mode 1, 2, 3	Temperature :	26~27°C
Test Engineer :	Ken Hsu	Relative Humidity :	52~53%
Number of Hopping Channels (Channel)		Limits (Channel)	
79		> 15	
		Pass/Fail	
		Pass	

Number of Hopping Channel Plot on Channel 00 - 78

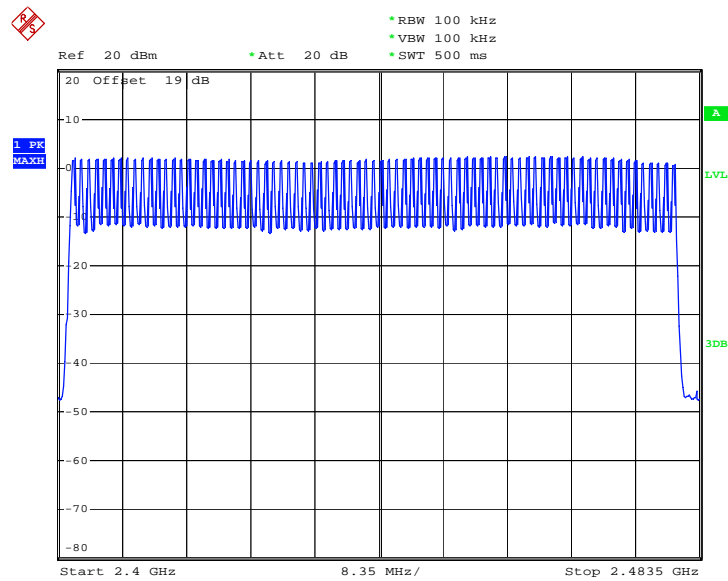

Date: 13.NOV.2008 21:15:50



Test Mode :	Mode 4, 5, 6	Temperature :	26~27°C
Test Engineer :	Ken Hsu	Relative Humidity :	52~53%

Number of Hopping Channels (Channel)	Limits (Channel)	Pass/Fail
79	> 15	Pass

Number of Hopping Channel Plot on Channel 00 - 78

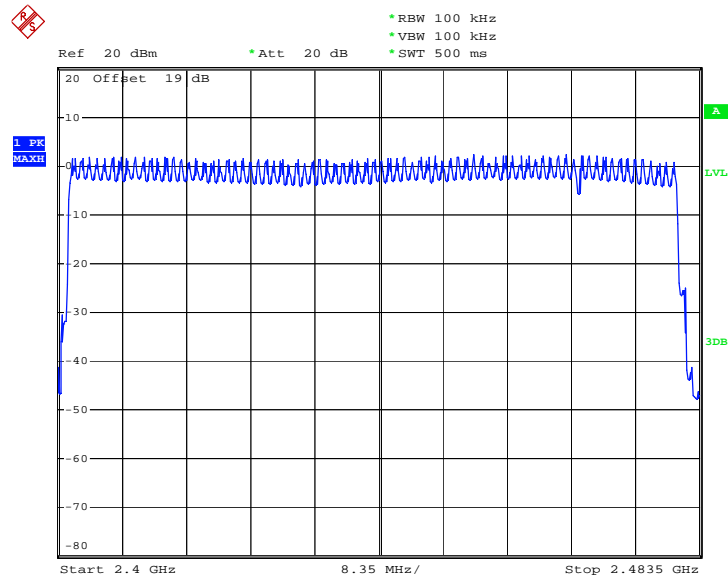

Date: 13.NOV.2008 21:21:51



Test Mode :	Mode 7, 8, 9	Temperature :	26~27°C
Test Engineer :	Ken Hsu	Relative Humidity :	52~53%

Number of Hopping Channels (Channel)	Limits (Channel)	Pass/Fail
79	> 15	Pass

Number of Hopping Channel Plot on Channel 00 - 78

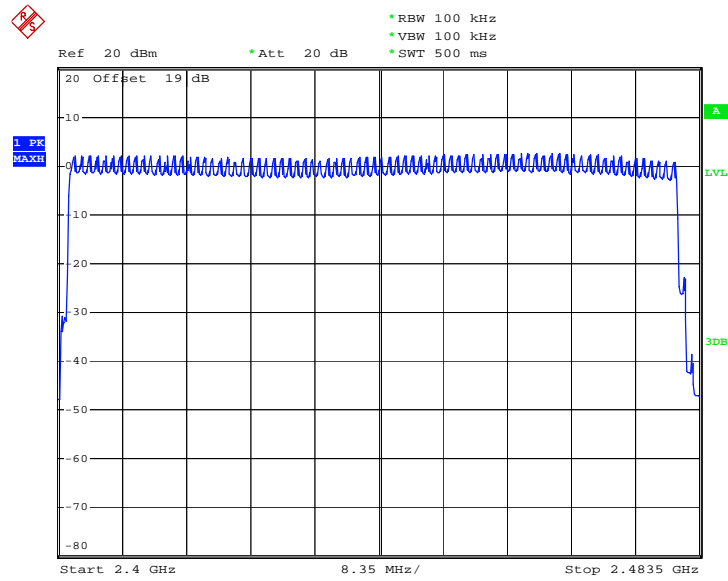

Date: 13.NOV.2008 21:37:21

3.2 20dB Bandwidth Measurement

3.2.1 Limit of 20dB Bandwidth

N/A

3.2.2 Measuring Instruments

See list of measuring instruments of this test report.

3.2.3 Test Procedures

1. The testing follows FCC Public Notice DA 00-705 Measurement Guidelines.
2. The RF output of EUT was connected to the spectrum analyzer by a low loss cable.
3. The EUT should be transmitting at its maximum data rate as the worst cases.
4. Use the following spectrum analyzer settings:
Span = approximately 2 to 3 times the 20 dB bandwidth, centered on a hopping channel;
RBW \geq 1% of the 20 dB bandwidth; VBW \geq RBW; Sweep = auto; Detector function = peak;
Trace = max hold.
5. The marker-delta reading at this point is the 20 dB bandwidth of the emission.

3.2.4 Test Setup

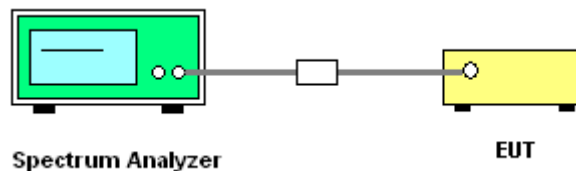

3.2.5 Test Result of 20dB Bandwidth

Test Mode :	Mode 1, 2, 3	Temperature :	26~27°C
Test Engineer :	Ken Hsu	Relative Humidity :	52~53%

Channel	Frequency (MHz)	20dB Bandwidth (MHz)
00	2402	0.903
39	2441	0.900
78	2480	0.903

20 dB Bandwidth Plot on Channel 00

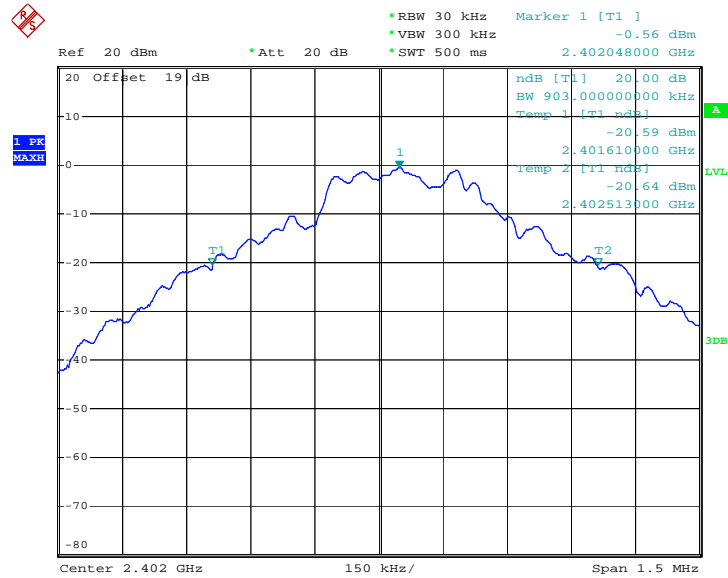

Date: 13.NOV.2008 20:07:11



20 dB Bandwidth Plot on Channel 39

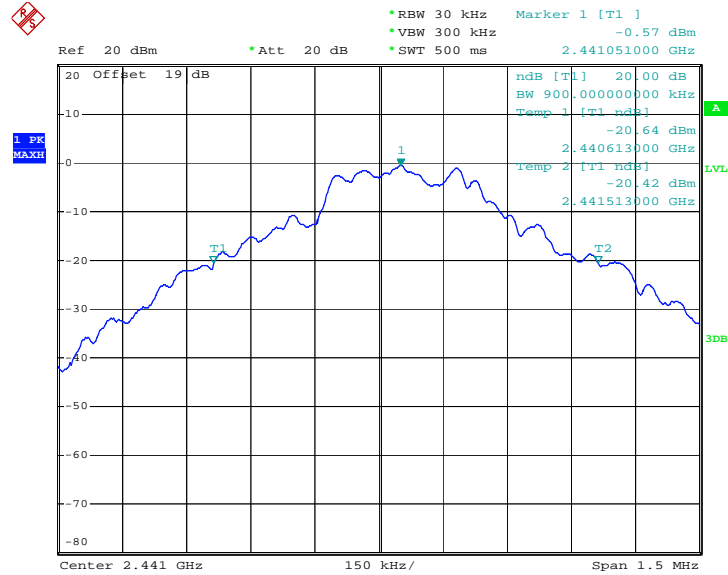

Date: 13.NOV.2008 20:07:30

20 dB Bandwidth Plot on Channel 78

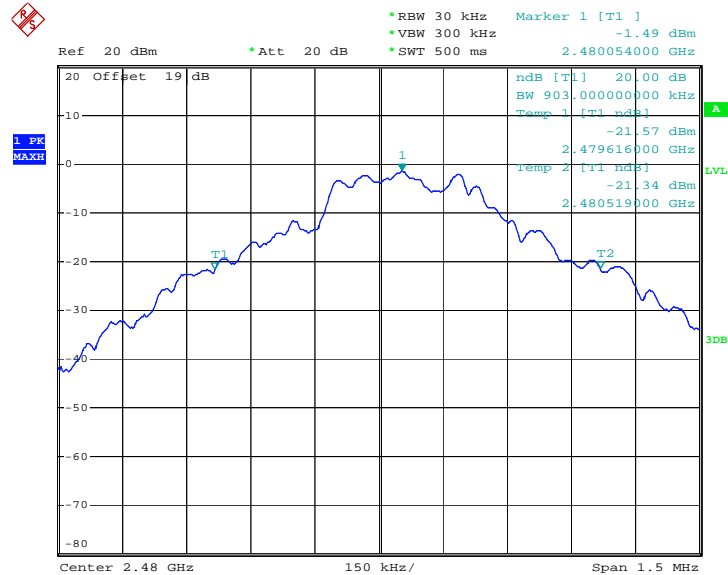

Date: 13.NOV.2008 20:07:47



Test Mode :	Mode 4, 5, 6	Temperature :	26~27°C
Test Engineer :	Ken Hsu	Relative Humidity :	52~53%

Channel	Frequency (MHz)	20dB Bandwidth (MHz)
00	2402	1.308
39	2441	1.300
78	2480	1.252

20 dB Bandwidth Plot on Channel 00

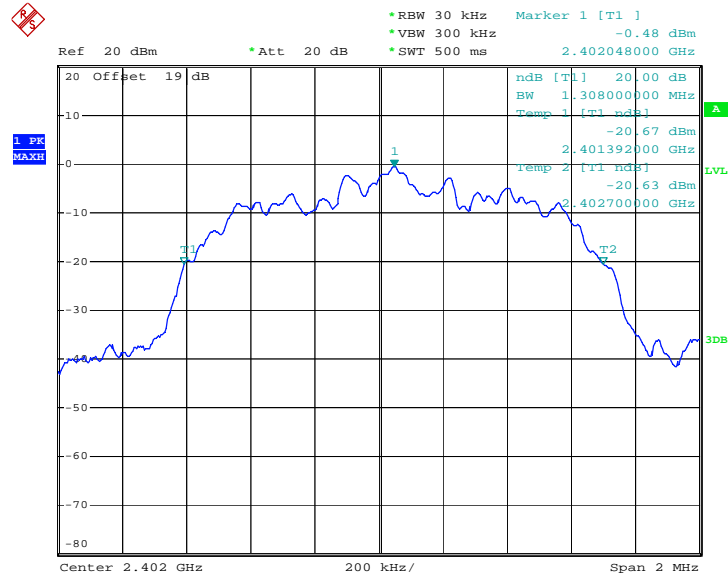

Date: 13.NOV.2008 20:09:42



20 dB Bandwidth Plot on Channel 39

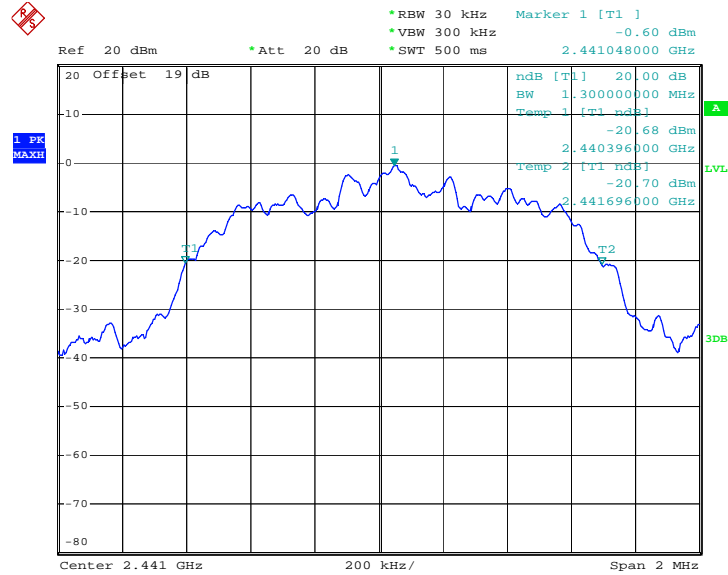

Date: 13.NOV.2008 20:09:01

20 dB Bandwidth Plot on Channel 78

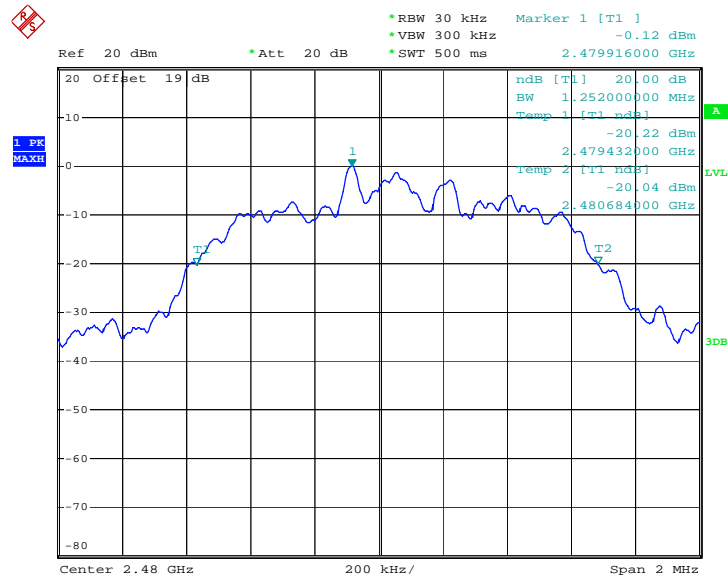

Date: 13.NOV.2008 20:08:41



Test Mode :	Mode 7, 8, 9	Temperature :	26~27°C
Test Engineer :	Ken Hsu	Relative Humidity :	52~53%

Channel	Frequency (MHz)	20dB Bandwidth (MHz)
00	2402	1.268
39	2441	1.264
78	2480	1.264

20 dB Bandwidth Plot on Channel 00

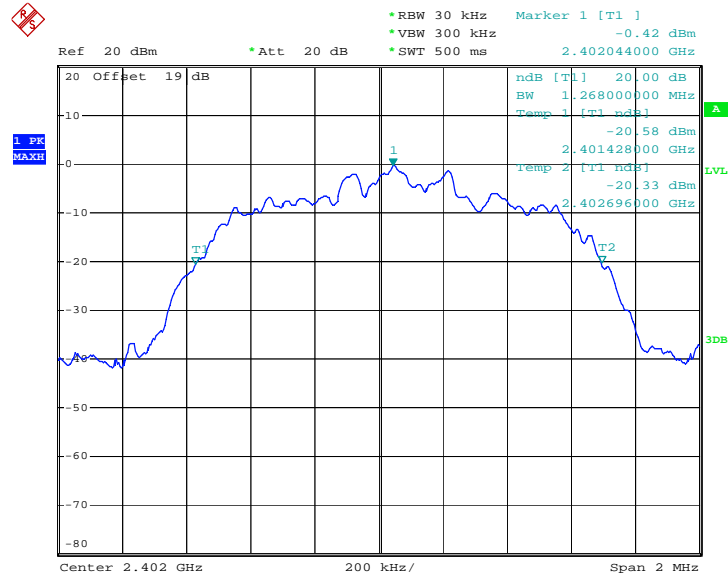

Date: 13.NOV.2008 20:10:53



20 dB Bandwidth Plot on Channel 39

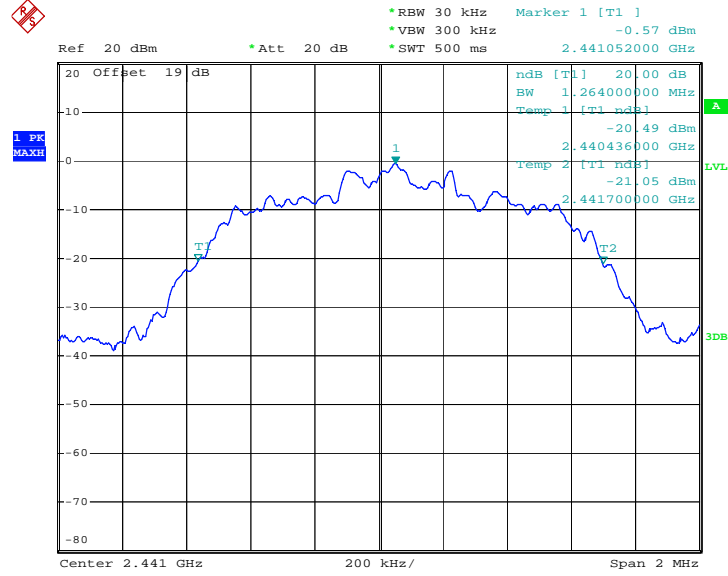

Date: 13.NOV.2008 20:11:08

20 dB Bandwidth Plot on Channel 78

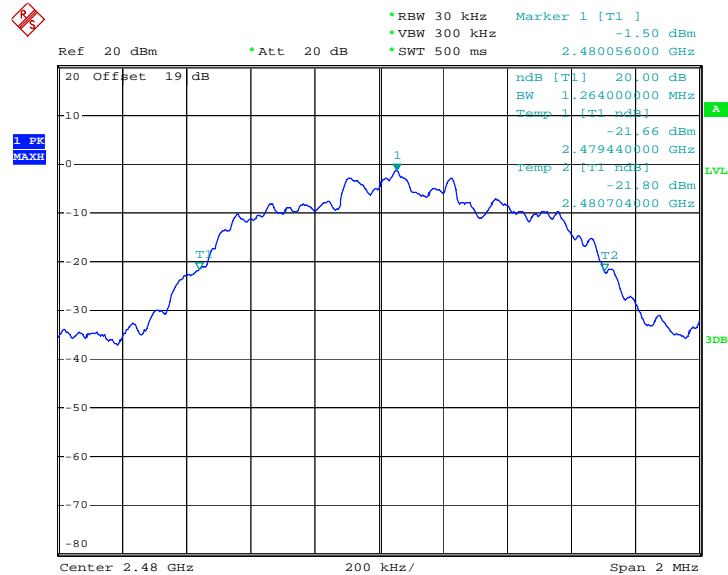

Date: 13.NOV.2008 20:11:35

3.3 Hopping Channel Separation Measurement

3.3.1 Limit of Hopping Channel Separation

Frequency hopping systems operating in the 2400-2483.5 MHz band may have hopping channel carrier frequencies that are separated by 25 kHz or two-thirds of the 20 dB bandwidth of the hopping channel, whichever is greater, provided the systems operate with an output power no greater than 125 mW.

3.3.2 Measuring Instruments

See list of measuring instruments of this test report.

3.3.3 Test Procedures

1. Please refer FCC Public Notice DA 00-705 Measurement Guidelines.
2. The RF output of EUT was connected to the spectrum analyzer by a low loss cable.
3. The EUT should be transmitting at its maximum data rate as the worst cases.
4. Use the following spectrum analyzer settings:
Span = wide enough to capture the peaks of two adjacent channels; $RBW \geq 1\%$ of the span;
 $VBW \geq RBW$; Sweep = auto; Detector function = peak; Trace = max hold.
5. Use the marker-delta function to determine the separation between the peaks of the adjacent channels.

3.3.4 Test Setup

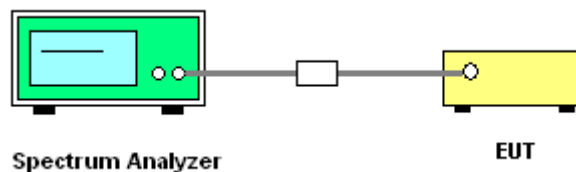



3.3.5 Test Result of Hopping Channel Separation

Test Mode :	Mode 1, 2, 3	Temperature :	26~27°C
Test Engineer :	Ken Hsu	Relative Humidity :	52~53%

Channel	Frequency (MHz)	Frequency Separation (MHz)	(2/3 of 20dB BW) Limits (MHz)	Pass/Fail
00	2402	1.004	0.602	Pass
39	2441	1.004	0.600	Pass
78	2480	1.000	0.602	Pass

Channel Separation Plot on Channel 00 - 01

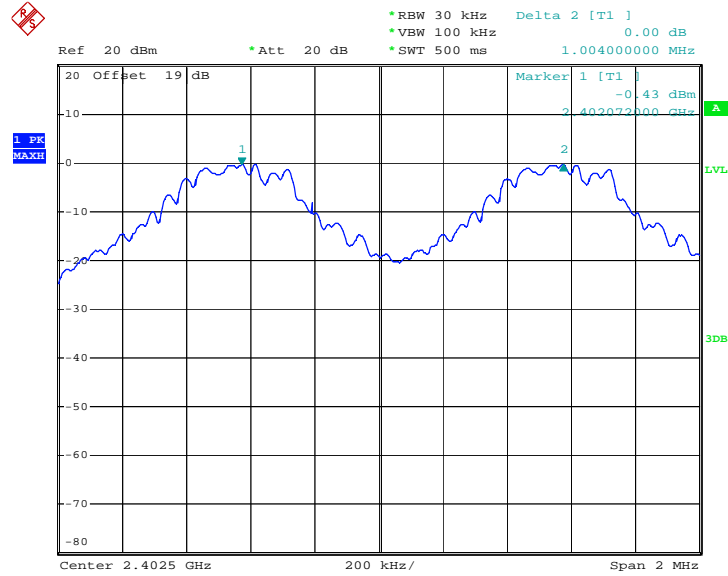

Date: 13.NOV.2008 20:32:12



Channel Separation Plot on Channel 39 - 40

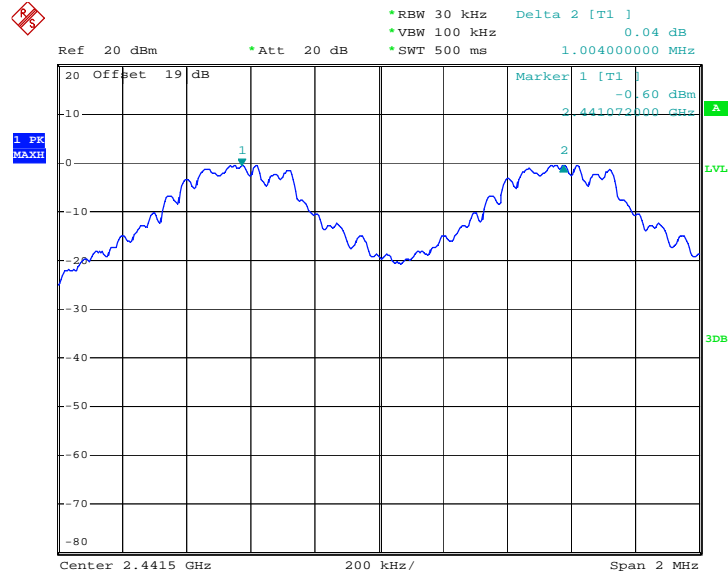

Date: 13.NOV.2008 20:32:45

Channel Separation Plot on Channel 77 - 78

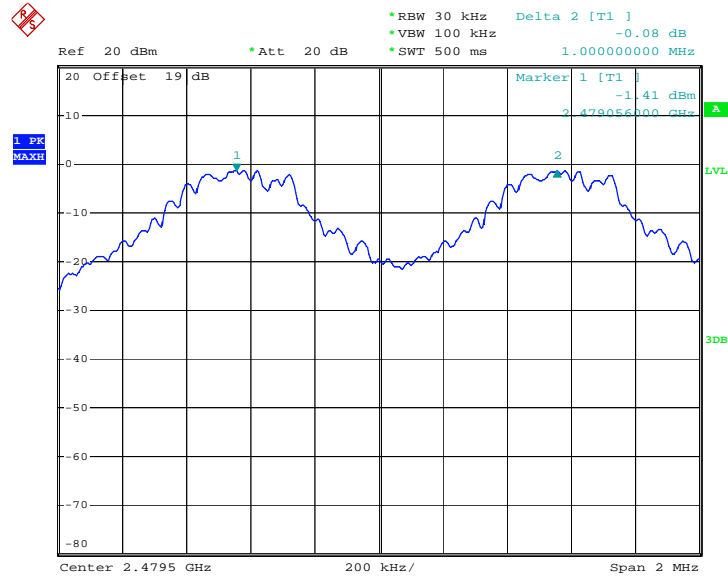

Date: 13.NOV.2008 20:33:40



Test Mode :	Mode 4, 5, 6	Temperature :	26~27°C
Test Engineer :	Ken Hsu	Relative Humidity :	52~53%

Channel	Frequency (MHz)	Frequency Separation (MHz)	(2/3 of 20dB BW) Limits (MHz)	Pass/Fail
00	2402	1.008	0.872	Pass
39	2441	1.000	0.867	Pass
78	2480	1.000	0.835	Pass

Channel Separation Plot on Channel 00 - 01

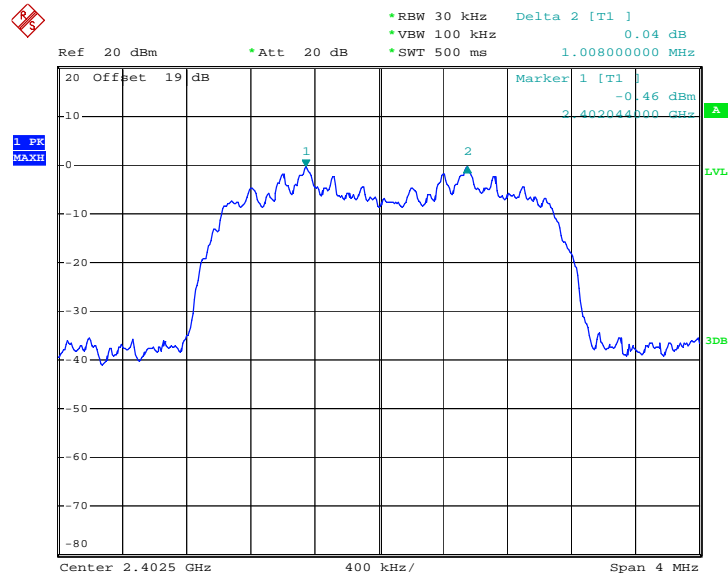

Date: 13.NOV.2008 20:34:59



Channel Separation Plot on Channel 39 - 40

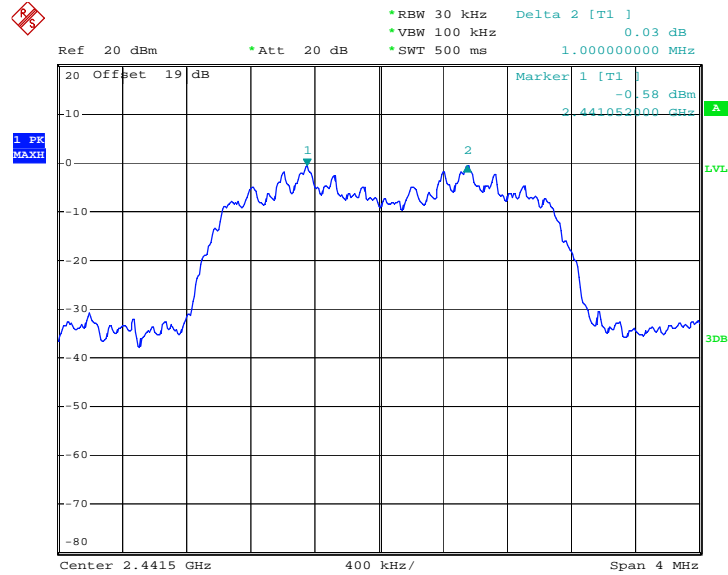

Date: 13.NOV.2008 20:35:40

Channel Separation Plot on Channel 77 - 78

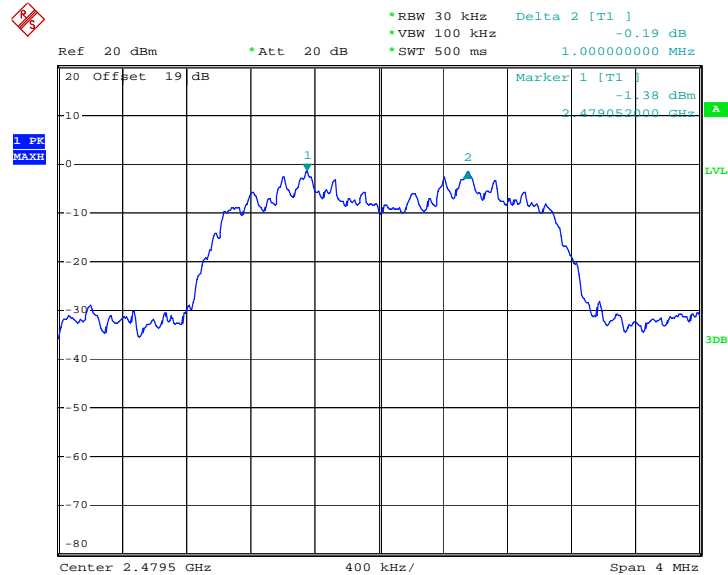

Date: 13.NOV.2008 20:36:17



Test Mode :	Mode 7, 8, 9	Temperature :	26~27°C
Test Engineer :	Ken Hsu	Relative Humidity :	52~53%

Channel	Frequency (MHz)	Frequency Separation (MHz)	(2/3 of 20dB BW) Limits (MHz)	Pass/Fail
00	2402	1.000	0.845	Pass
39	2441	1.000	0.843	Pass
78	2480	1.000	0.843	Pass

Channel Separation Plot on Channel 00 - 01

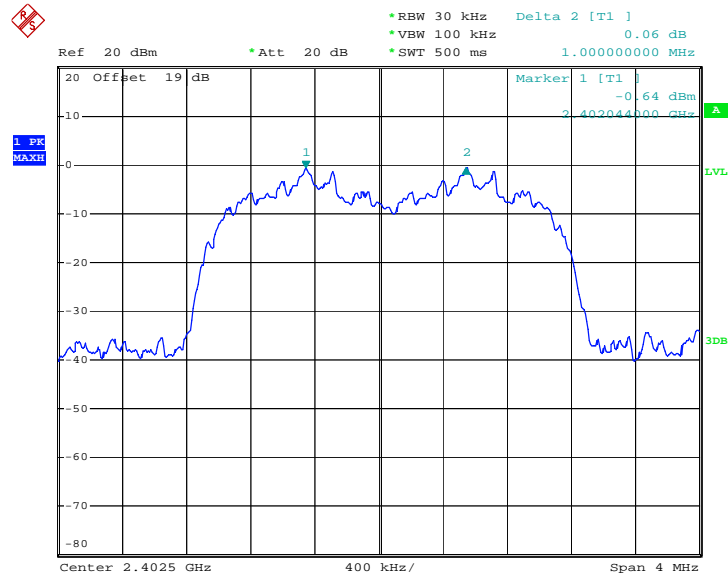

Date: 13.NOV.2008 20:36:56



Channel Separation Plot on Channel 39 - 40

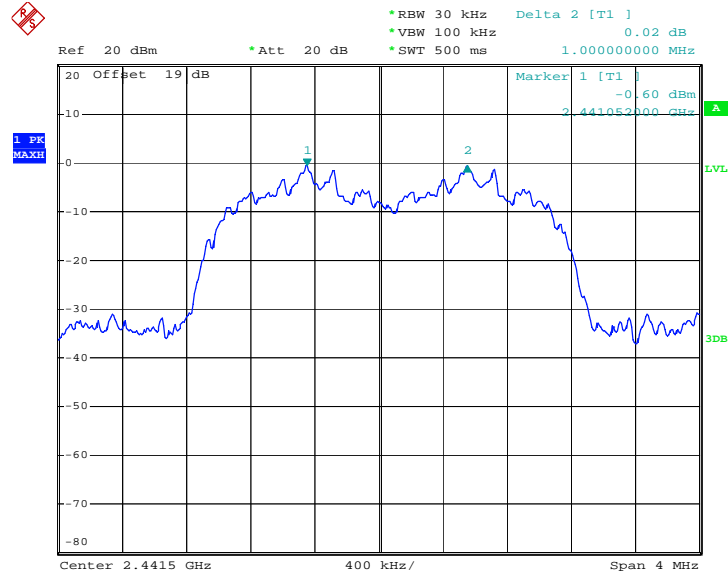

Date: 13.NOV.2008 20:38:08

Channel Separation Plot on Channel 77 - 78

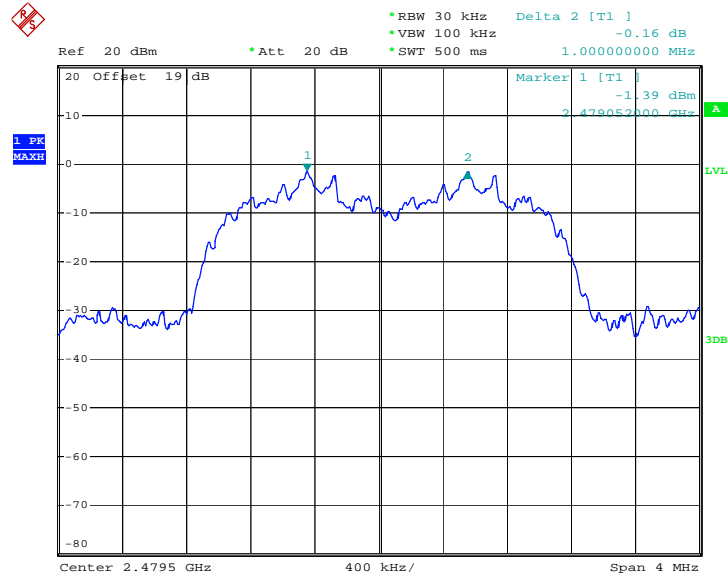

Date: 13.NOV.2008 20:38:38

3.4 Dwell Time Measurement

3.4.1 Limit of Dwell Time

The average time of occupancy on any channel shall not be greater than 0.4 seconds within a period of 0.4 seconds multiplied by the number of hopping channels employed.

3.4.2 Measuring Instruments

See list of measuring instruments of this test report.

3.4.3 Test Procedures

1. The testing follows FCC Public Notice DA 00-705 Measurement Guidelines.
2. The RF output of EUT was connected to the spectrum analyzer by a low loss cable.
3. The EUT should be transmitting at its maximum data rate as the worst cases.
4. The EUT must have its hopping function enabled. Use the following spectrum analyzer settings:
Span = zero span, centered on a hopping channel; RBW = 1 MHz; VBW \geq RBW; Sweep = as necessary to capture the entire dwell time per hopping channel; Detector function = peak; Trace = max hold.
5. Use the marker-delta function to calculate the dwell time.

3.4.4 Test Setup

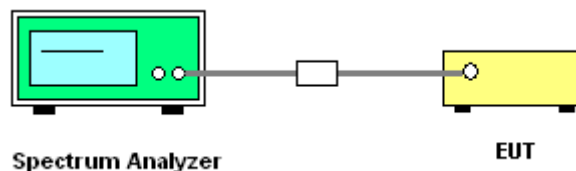

3.4.5 Test Result of Dwell Time

Test Mode :	Mode 2	Temperature :	26~27°C
Test Engineer :	Ken Hsu	Relative Humidity :	52~53%

Package Mode	Average Hopping Channel	Package Transfer Time (usec)	Dwell Time (sec)	Limits (sec)	Pass/Fail
DH1	8.10	408.00	0.104	0.4	Pass
DH3	4.50	1690.00	0.240	0.4	Pass
DH5	3.00	2940.00	0.279	0.4	Pass

Remark:

1. Dwell Time=79(channels) x 0.4(s) x average hopping channel x package transfer time
2. 79 channels come from the Hopping Channel number.
3. Average Hopping Channel = hops/sweep time
4. t: Package Transfer Time(us)



DH1 Dwell Time (One Pulse) Plot on Channel 39_1Mbps

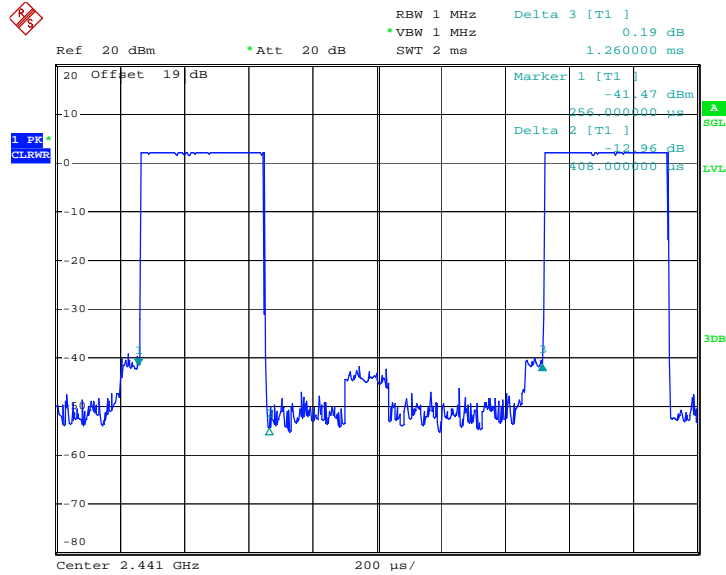

Date: 13.NOV.2008 20:42:24

DH1 Dwell Time (Count Pulses) Plot on Channel 39_1Mbps

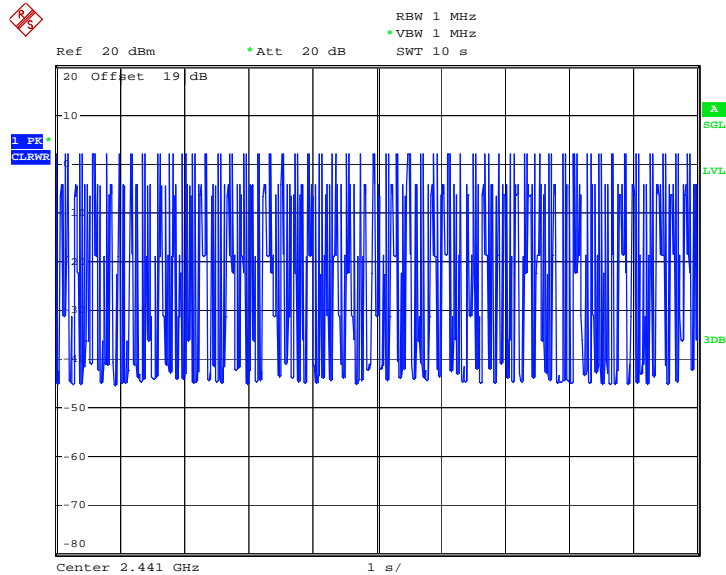

Date: 13.NOV.2008 20:51:46



DH3 Dwell Time (One Pulse) Plot on Channel 39_1Mbps

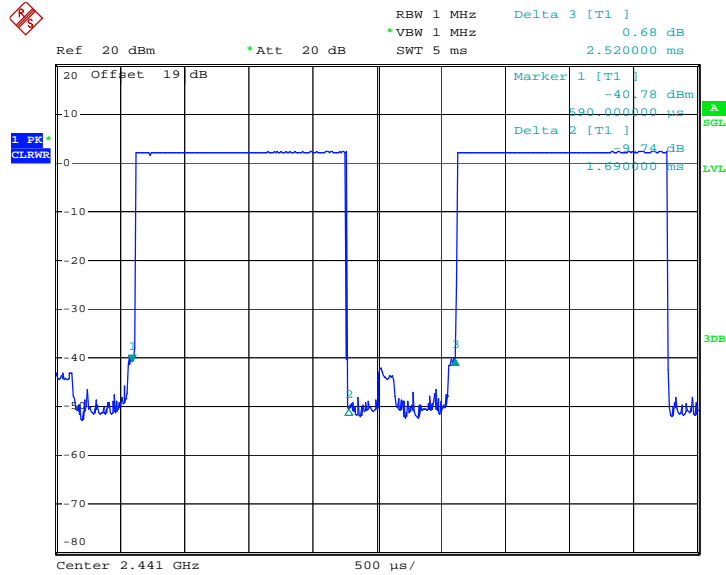

Date: 13.NOV.2008 20:43:03

DH3 Dwell Time (Count Pulses) Plot on Channel 39_1Mbps

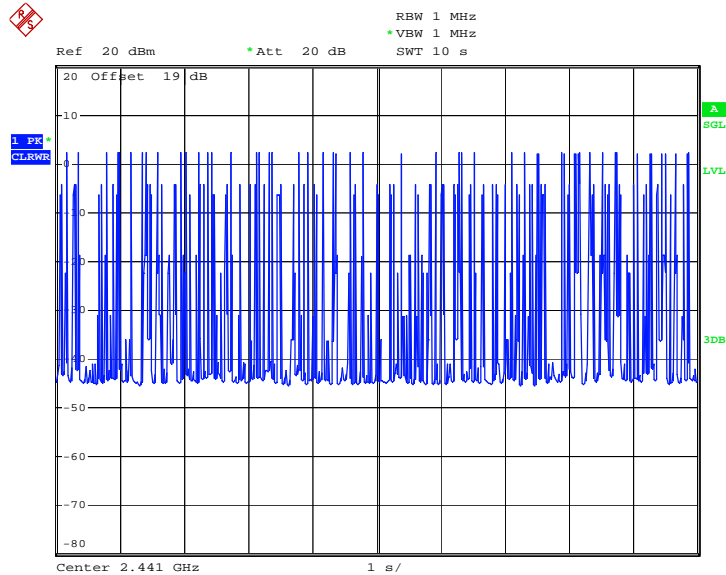

Date: 13.NOV.2008 20:52:26



DH5 Dwell Time (One Pulse) Plot on Channel 39_1Mbps

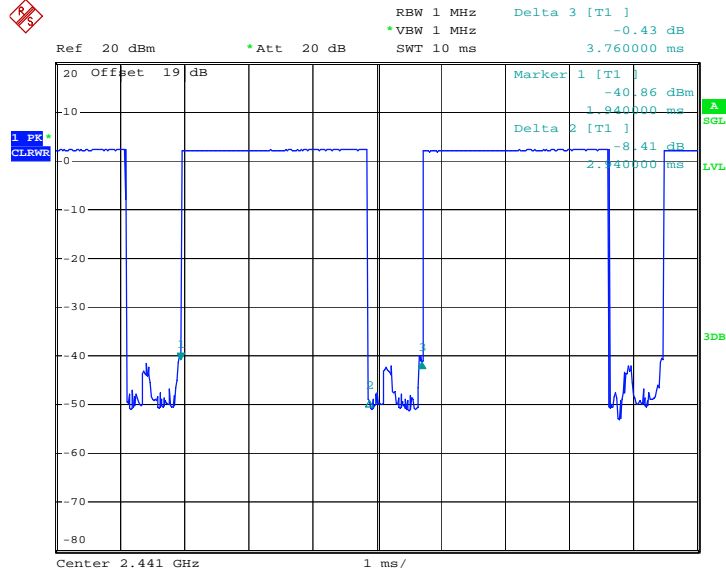

Date: 13.NOV.2008 20:43:50

DH5 Dwell Time (Count Pulses) Plot on Channel 39_1Mbps

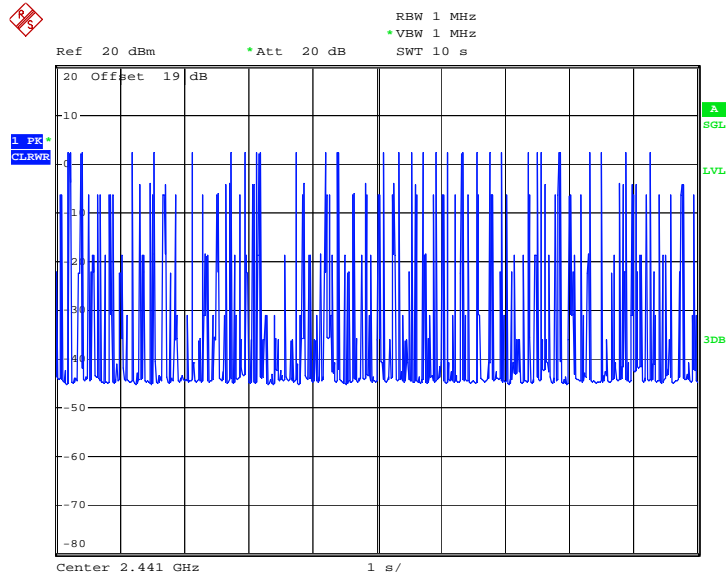

Date: 13.NOV.2008 20:53:36



Test Mode :	Mode 5	Temperature :	26~27°C
Test Engineer :	Ken Hsu	Relative Humidity :	52~53%

Package Mode	Average Hopping Channel	Package Transfer Time (usec)	Dwell Time (sec)	Limits (sec)	Pass/Fail
DH1	8.10	412.00	0.105	0.4	Pass
DH3	4.40	1672.00	0.232	0.4	Pass
DH5	2.80	2960.00	0.262	0.4	Pass

Remark:

- 5. Dwell Time=79(channels) x 0.4(s) x average hopping channel x package transfer time
- 6. 79 channels come from the Hopping Channel number.
- 7. Average Hopping Channel = hops/sweep time
- 8. t: Package Transfer Time(us)



DH1 Dwell Time (One Pulse) Plot on Channel 39_2Mbps

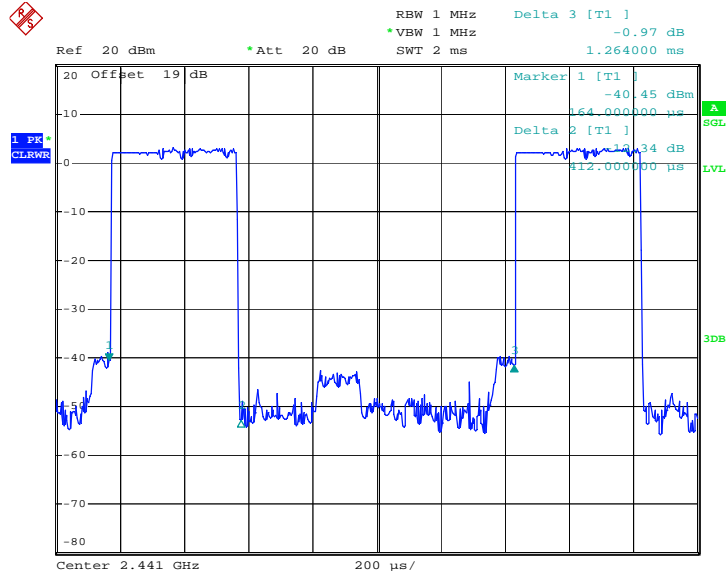

Date: 13.NOV.2008 20:44:40

DH1 Dwell Time (Count Pulses) Plot on Channel 39_1Mbps

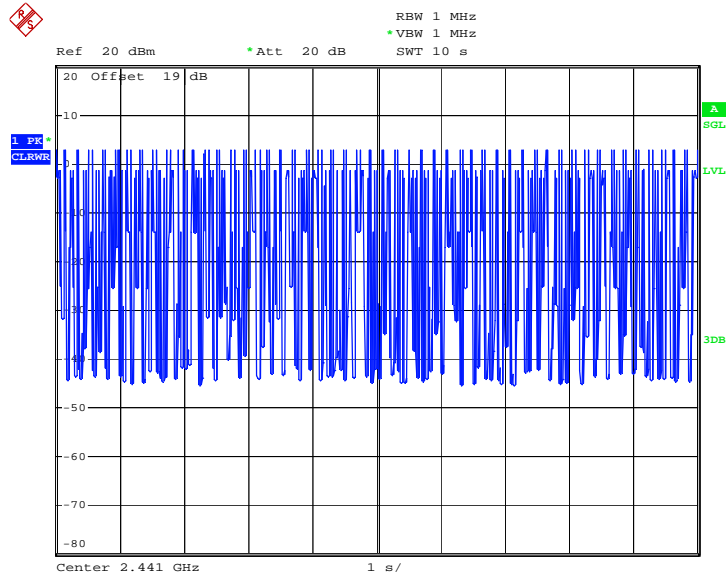

Date: 13.NOV.2008 20:54:11



DH3 Dwell Time (One Pulse) Plot on Channel 39_1Mbps

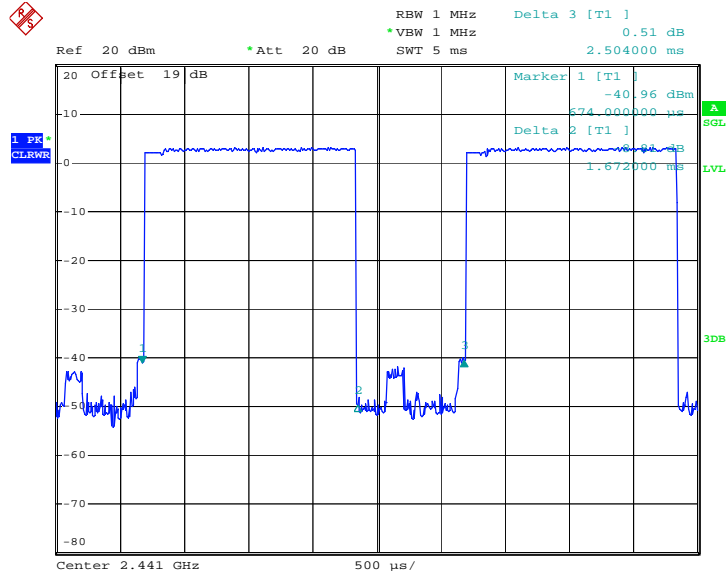

Date: 13.NOV.2008 20:45:20

DH3 Dwell Time (Count Pulses) Plot on Channel 39_1Mbps

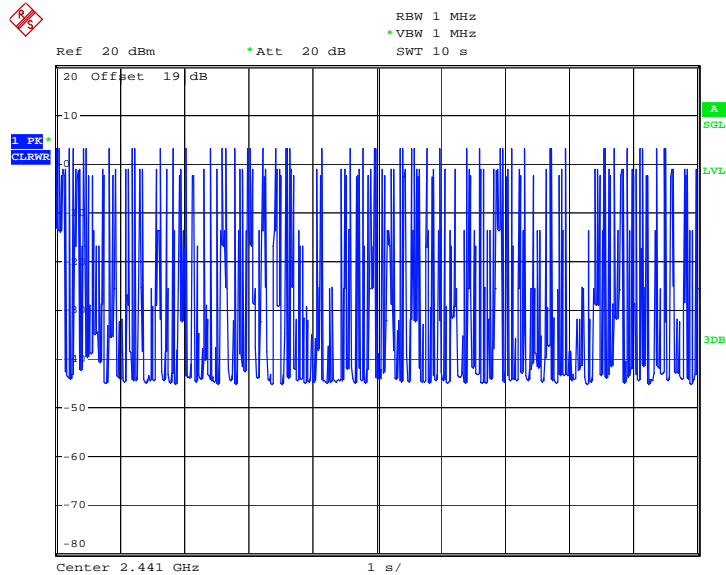

Date: 13.NOV.2008 20:54:48



DH5 Dwell Time (One Pulse) Plot on Channel 39_1Mbps

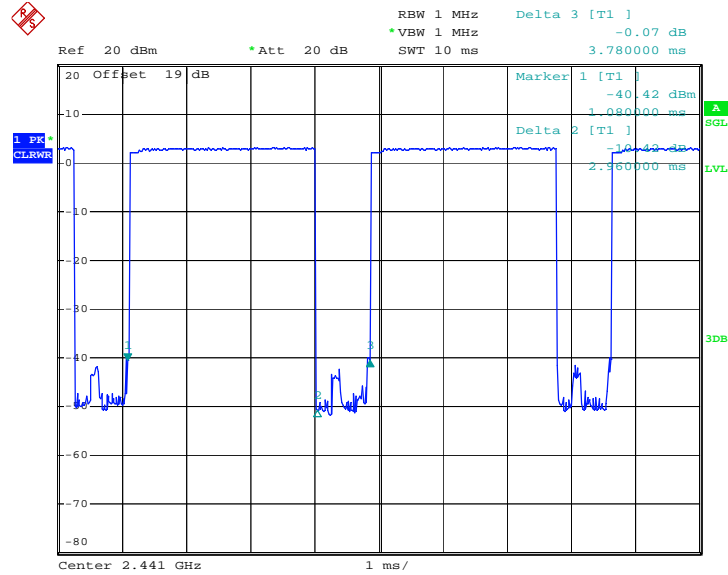

Date: 13.NOV.2008 20:47:25

DH5 Dwell Time (Count Pulses) Plot on Channel 39_1Mbps

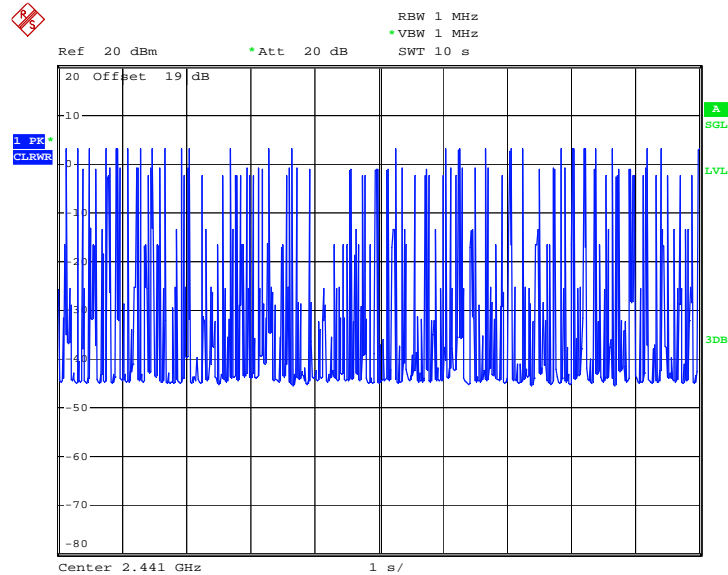

Date: 13.NOV.2008 20:55:14



Test Mode :	Mode 8	Temperature :	26~27°C
Test Engineer :	Ken Hsu	Relative Humidity :	52~53%

Package Mode	Average Hopping Channel	Package Transfer Time (usec)	Dwell Time (sec)	Limits (sec)	Pass/Fail
DH1	8.70	424.00	0.117	0.4	Pass
DH3	4.80	1700.00	0.258	0.4	Pass
DH5	3.30	3000.00	0.313	0.4	Pass

Remark:

- 9. Dwell Time=79(channels) x 0.4(s) x average hopping channel x package transfer time
- 10. 79 channels come from the Hopping Channel number.
- 11. Average Hopping Channel = hops/sweep time
- 12. t: Package Transfer Time(us)



DH1 Dwell Time (One Pulse) Plot on Channel 39_3Mbps

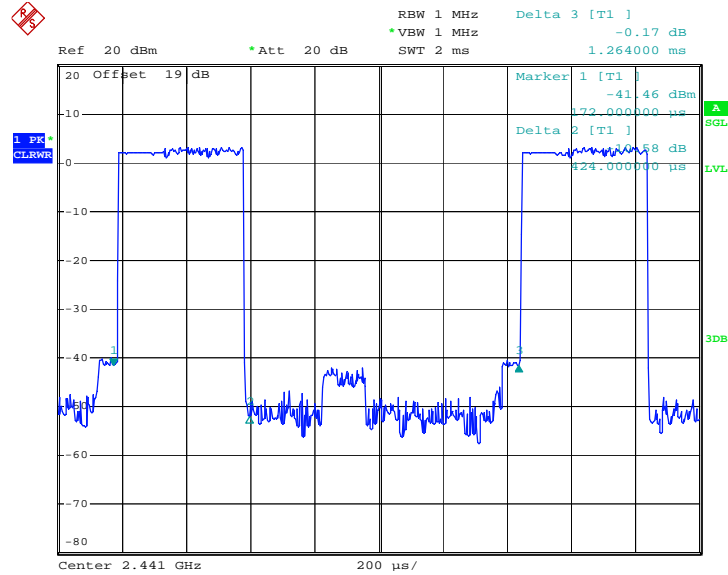

Date: 13.NOV.2008 20:49:25

DH1 Dwell Time (Count Pulses) Plot on Channel 39_3Mbps

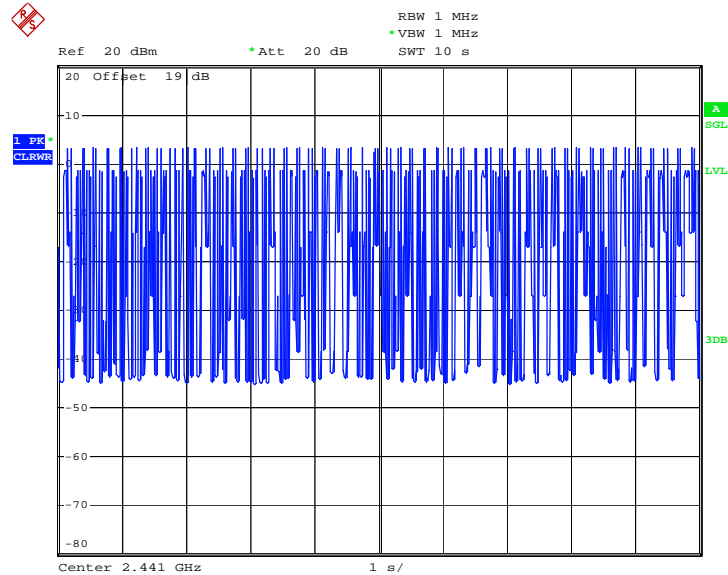

Date: 13.NOV.2008 20:56:04



DH3 Dwell Time (One Pulse) Plot on Channel 39_3Mbps

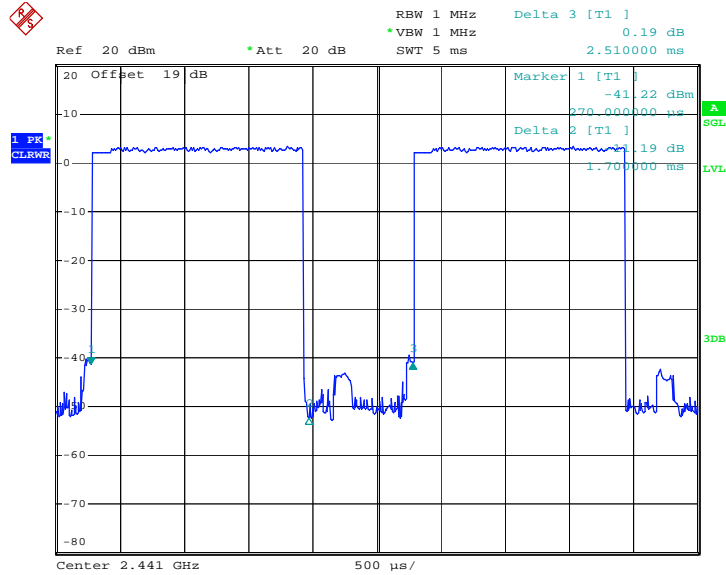

Date: 13.NOV.2008 20:49:52

DH3 Dwell Time (Count Pulses) Plot on Channel 39_3Mbps

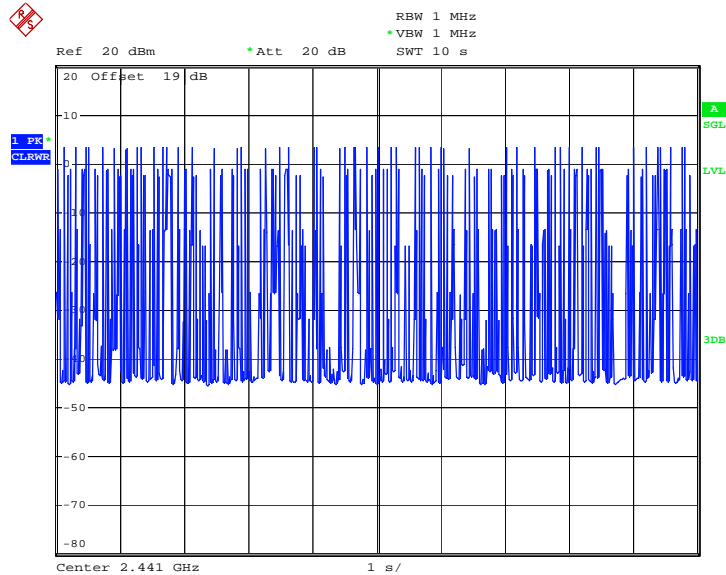

Date: 13.NOV.2008 20:56:24



DH5 Dwell Time (One Pulse) Plot on Channel 39_3Mbps

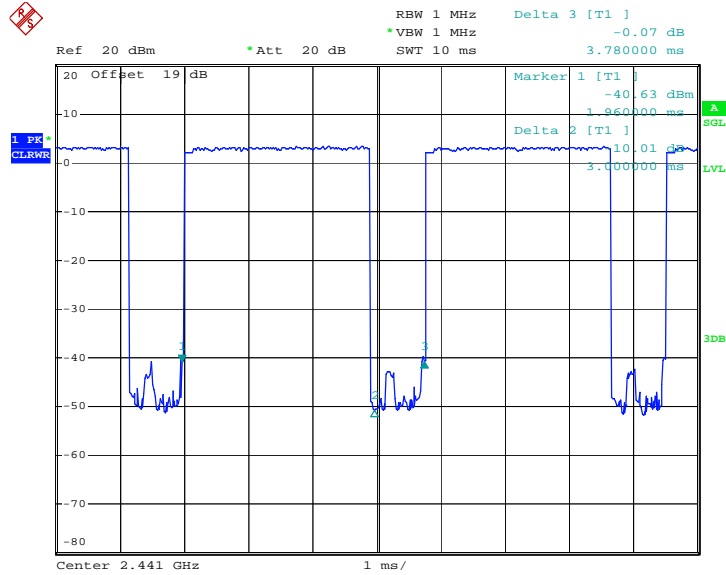

Date: 13.NOV.2008 20:50:19

DH5 Dwell Time (Count Pulses) Plot on Channel 39_3Mbps

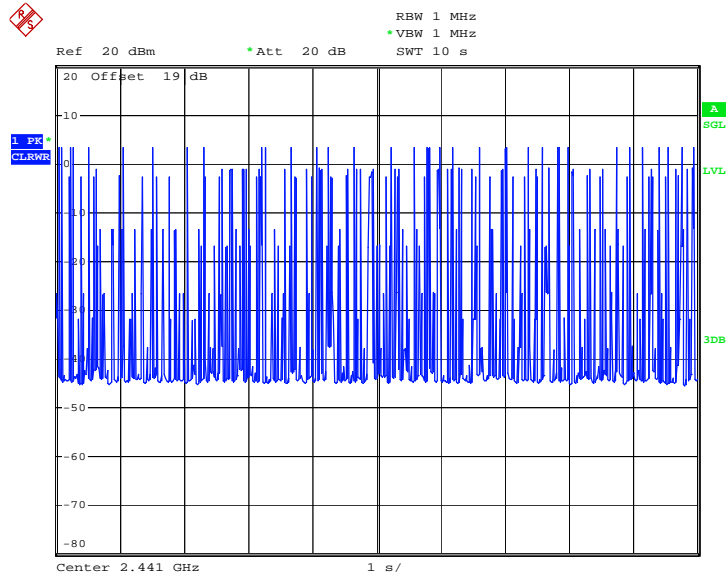

Date: 13.NOV.2008 20:57:14

3.5 Peak Output Power Measurement

3.5.1 Limit of Peak Output Power

Frequency hopping systems operating in the 2400-2483.5 MHz band may have hopping channel carrier frequencies that are separated by 25 kHz or two-thirds of the 20 dB bandwidth of the hopping channel, whichever is greater, provided the systems operate with an output power no greater than 125 mW (20.97dBm).

3.5.2 Measuring Instruments

See list of measuring instruments of this test report.

3.5.3 Test Procedures

1. The testing follows FCC Public Notice DA 00-705 Measurement Guidelines.
2. The RF output of EUT was connected to the peak power meter by a low loss cable.

3.5.4 Test Setup

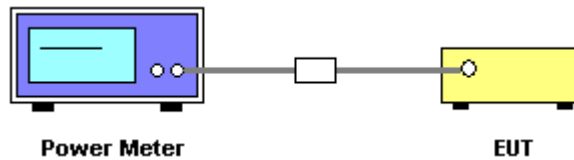

3.5.5 Test Result of Peak Output Power

Test Mode :	Mode 1, 2, 3	Temperature :	26~27°C
Test Engineer :	Ken Hsu	Relative Humidity :	52~53%

Channel	Frequency (MHz)	RF Power (dBm)		
		GFSK	Max. Limits (dBm)	Pass/Fail
		1 Mbps		
00	2402	2.49	20.97	Pass
39	2441	2.31	20.97	Pass
78	2480	1.35	20.97	Pass



Peak Output Power Plot on Channel 00

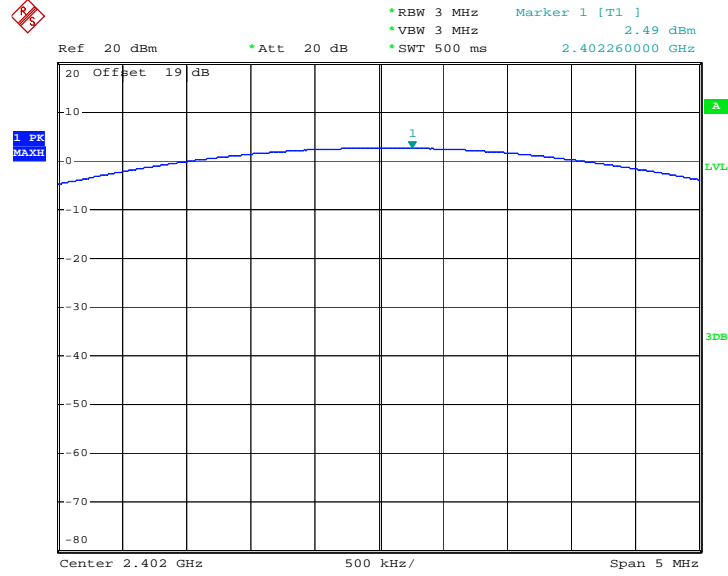

Date: 13.NOV.2008 19:16:52

Peak Output Power Plot on Channel 39

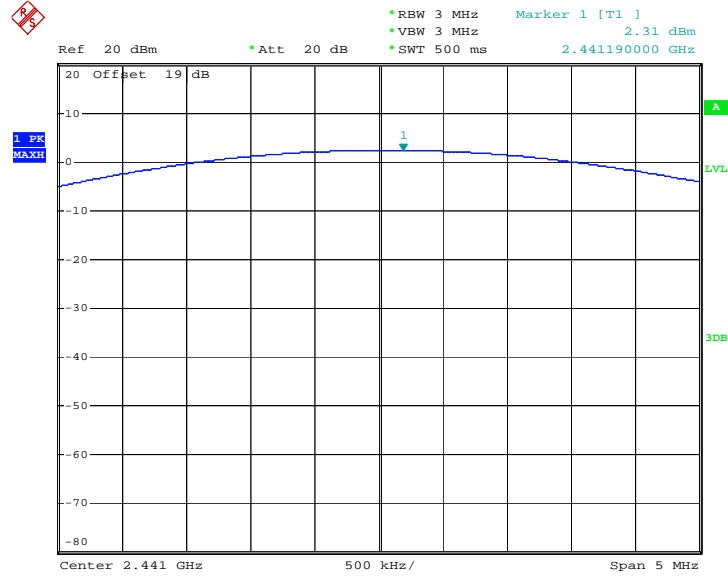

Date: 13.NOV.2008 19:18:33



Peak Output Power Plot on Channel 78

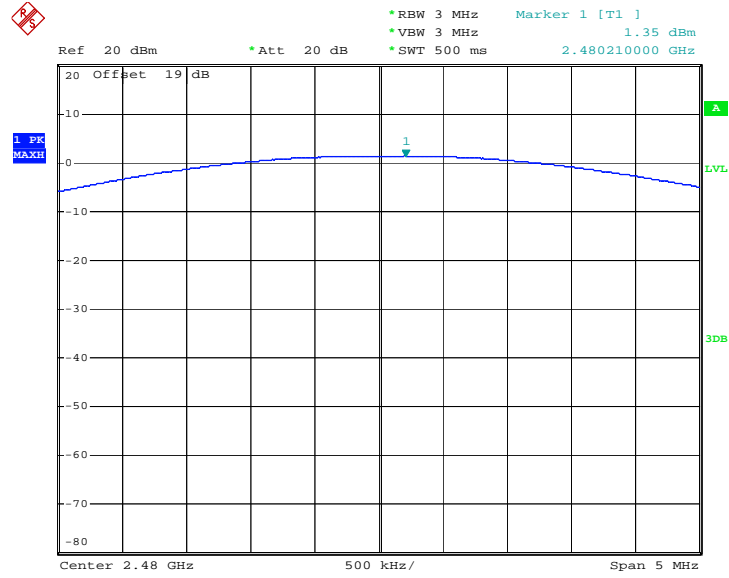

Date: 13.NOV.2008 19:22:25



Test Mode :	Mode 4, 5, 6	Temperature :	26~27°C
Test Engineer :	Ken Hsu	Relative Humidity :	52~53%

Channel	Frequency (MHz)	RF Power (dBm)		
		$\pi/4$ -DQPSK	Max. Limits (dBm)	Pass/Fail
		2 Mbps		
00	2402	4.20	20.97	Pass
39	2441	3.57	20.97	Pass
78	2480	2.26	20.97	Pass



Peak Output Power Plot on Channel 00

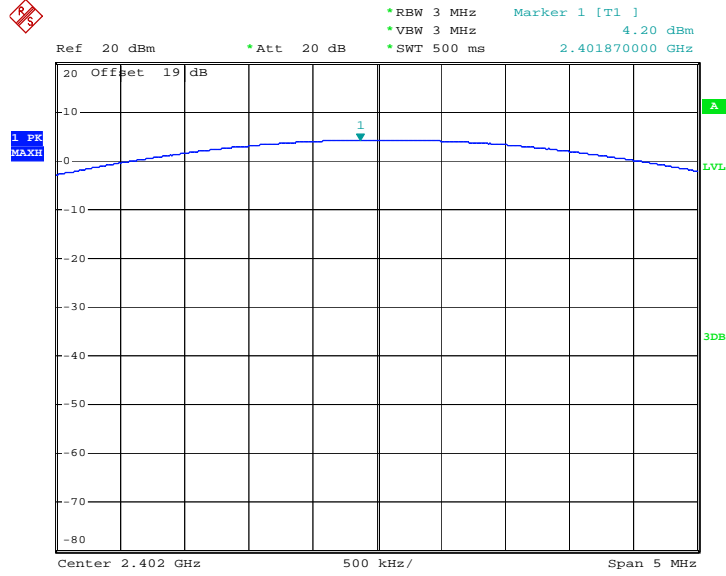

Date: 13.NOV.2008 19:29:52

Peak Output Power Plot on Channel 39

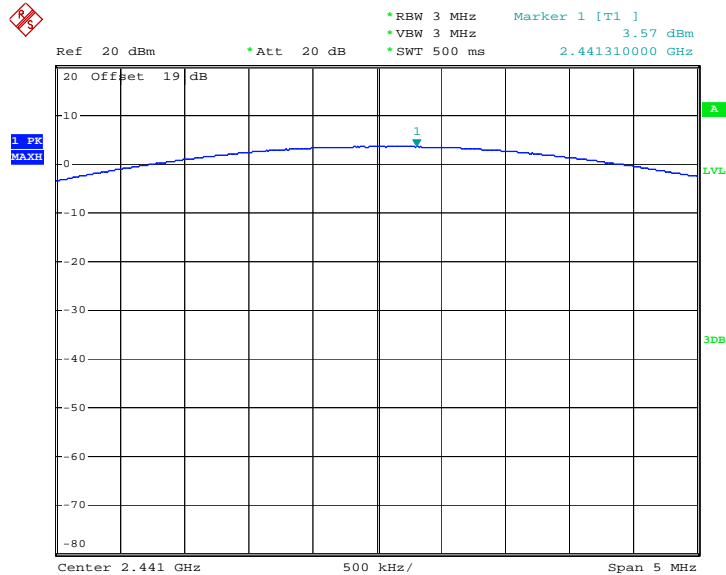

Date: 13.NOV.2008 19:26:02



Peak Output Power Plot on Channel 78

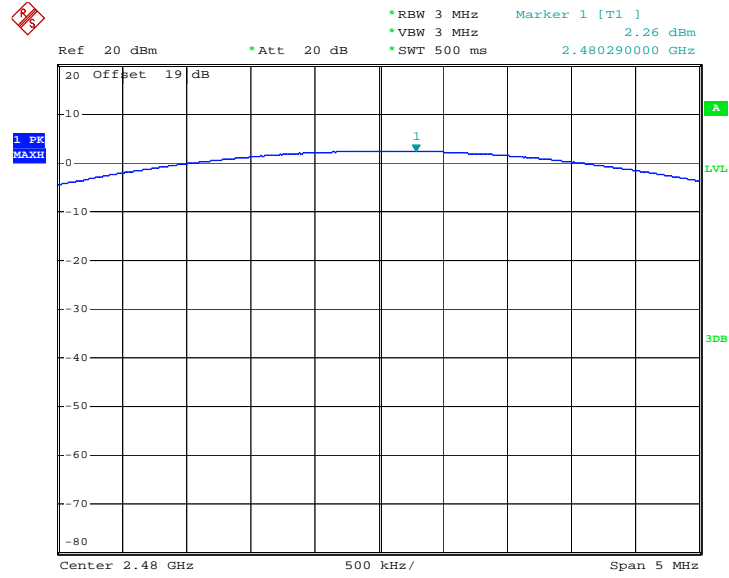

Date: 13.NOV.2008 19:24:52



Test Mode :	Mode 7, 8, 9	Temperature :	26~27°C
Test Engineer :	Ken Hsu	Relative Humidity :	52~53%

Channel	Frequency (MHz)	RF Power (dBm)		
		8-DPSK	Max. Limits (dBm)	Pass/Fail
		3 Mbps		
00	2402	4.67	20.97	Pass
39	2441	3.81	20.97	Pass
78	2480	2.45	20.97	Pass



Peak Output Power Plot on Channel 00

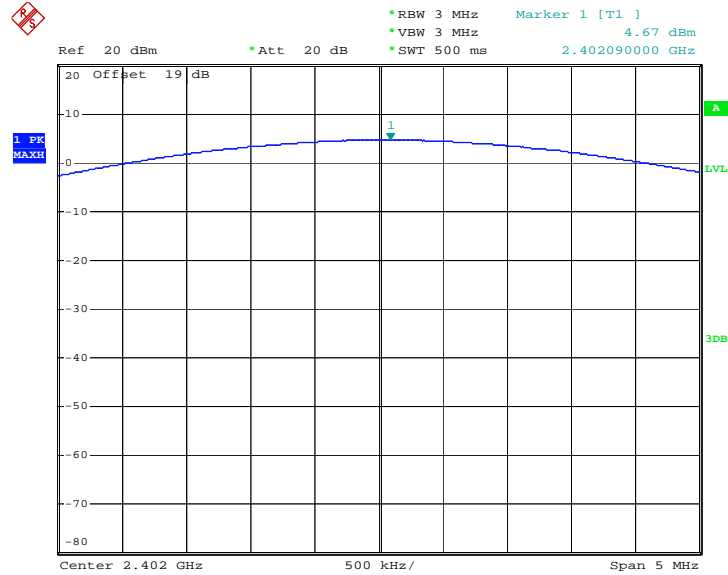

Date: 13.NOV.2008 19:32:31

Peak Output Power Plot on Channel 39

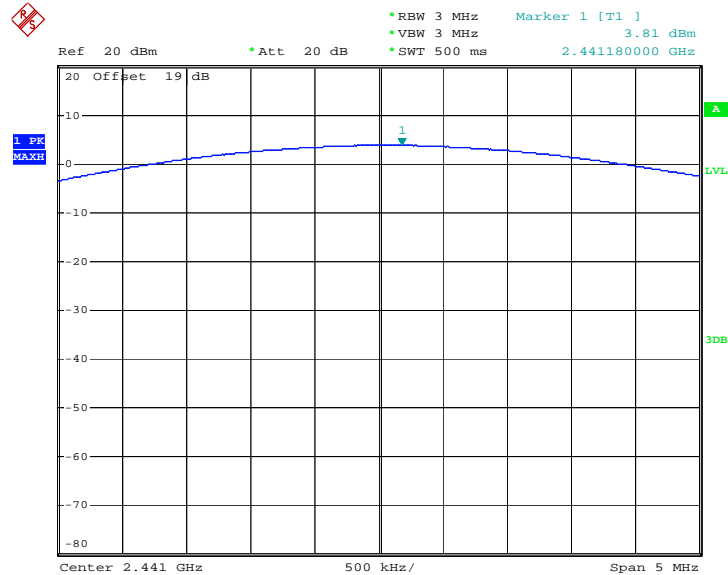

Date: 13.NOV.2008 19:33:22



Peak Output Power Plot on Channel 78

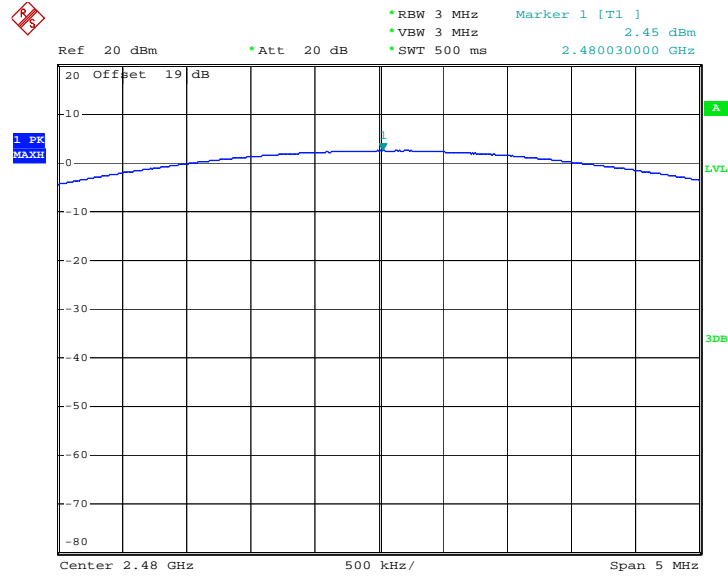

Date: 13.NOV.2008 19:36:43

3.6 Band Edges Measurement

3.6.1 Limit of Band Edges

In any 100 kHz bandwidth outside the intentional radiation frequency band, the radio frequency power shall be at least 20 dB below the highest level of the radiated power. In addition, radiated emissions which fall in the restricted bands must also comply with the radiated emission limits.

3.6.2 Measuring Instruments

See list of measuring instruments of this test report.

3.6.3 Test Procedures

1. The testing follows the guidelines in ANSI C63.4-2003 and FCC Public Notice DA 00-705 Measurement Guidelines.
2. RF antenna conducted test: Set RBW = 100 kHz, Video bandwidth (VBW) > RBW, scan up through 10th harmonic. Bandedge emissions must be at least 20 dB down from the highest emission level within the authorized band as measured with a 100 kHz RBW. Note: If the device complies with the use of power option 2 the attenuation under this paragraph shall be 30 dB instead of 20 dB.
3. Radiated emission test: Applies to bandedge emissions that fall in the restricted bands listed in FCC Section 15.205. The maximum permitted average field strength is listed in FCC Section 15.209. A pre-amp is necessary for this measurement. For measurements above 1 GHz, set RBW = 1MHz, VBW = 10 Hz, Sweep: Auto. If the emission is pulsed, modify the unit for continuous operation; use the settings shown above, then correct the reading by subtracting the peak-average correction factor, derived from the appropriate duty cycle calculation. See FCC Section 15.35(b) and (c).

3.6.4 Test Setup

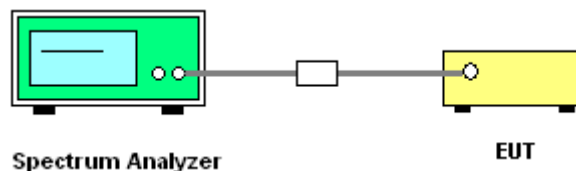



3.6.5 Test Result of Radiated Band Edges

Test Mode :	Mode 1	Temperature :	26~28°C
Test Channel :	CH00_2402 MHz (1D Scanner with Battery 3600mAh)	Relative Humidity :	41~43%
Test Engineer :	Kay Wu		

ANTENNA POLARITY : HORIZONTAL										
Frequency (MHz)	Level (dBuV/m)	Over Limit (dB)	Limit Line (dBuV/m)	Read Level (dBuV)	Antenna Factor (dB)	Cable Loss (dB)	Preamp Factor (dB)	Ant Pos (cm)	Table Pos (deg)	Remark
2341.54	46.48	-27.52	74.00	44.32	32.33	5.50	35.67	100	0	Peak
2341.54	6.39	-47.61	54.00	4.23	32.33	5.50	35.67	100	171	Average

Remark:

<Delta Marker>

Delta marker at 1% RBW of span = 48.89 dB

Peak band edge at 2341.54 MHz with RBW = VBW = 1MHz = 95.37 dBuV/m – 48.89 dB = 46.48 dBuV/m

Duty factor = 20 log (Package Transfer Times x Avg Hopping Channel) = 20 log (0.003 x 3.3) = -40.09

Average band edge = Peak band edge + Duty factor = 46.48 dBuV/m + (-40.09) = 6.39 dBuV/m

ANTENNA POLARITY : VERTICAL										
Frequency (MHz)	Level (dBuV/m)	Over Limit (dB)	Limit Line (dBuV/m)	Read Level (dBuV)	Antenna Factor (dB)	Cable Loss (dB)	Preamp Factor (dB)	Ant Pos (cm)	Table Pos (deg)	Remark
2330.14	49.08	-24.92	74.00	46.93	32.30	5.51	35.67	100	0	Peak
2330.14	8.99	-45.01	54.00	6.84	32.30	5.51	35.67	177	312	Average

Remark:

<Delta Marker>

Delta marker at 1% RBW of span = 48.89 dB

Peak band edge at 2330.14 MHz with RBW = VBW = 1MHz = 97.97 dBuV/m – 48.89 dB = 49.08 dBuV/m

Duty factor = 20 log (Package Transfer Times x Avg Hopping Channel) = 20 log (0.003 x 3.3) = -40.09

Average band edge = Peak band edge + Duty factor = 49.08 dBuV/m + (-40.09) = 8.99 dBuV/m



Test Mode :	Mode 3	Temperature :	26~28°C
Test Channel :	CH78_2480 MHz (1D Scanner with Battery 3600mAh)	Relative Humidity :	41~43%
Test Engineer :	Kay Wu		

ANTENNA POLARITY : HORIZONTAL										
Frequency (MHz)	Level (dBuV/m)	Over Limit (dB)	Limit Line (dBuV/m)	Read Level (dBuV)	Antenna Factor (dB)	Cable Loss (dB)	Preamp Factor (dB)	Ant Pos (cm)	Table Pos (deg)	Remark
2483.50	47.62	-26.38	74.00	45.63	32.30	5.38	35.70	100	0	Peak
2483.50	7.53	-46.47	54.00	5.54	32.30	5.38	35.70	100	1	Average

Remark:

<Delta Marker>

Delta marker at 1% RBW of span = 47.09 dB

Peak band edge at 2483.5 MHz with RBW = VBW = 1MHz = 94.71 dBuV/m – 47.09 dB = 47.62 dBuV/m

Duty factor = 20 log (Package Transfer Times x Avg Hopping Channel) = 20 log (0.003 x 3.3) = -40.09

Average band edge = Peak band edge + Duty factor = 47.62 dBuV/m + (-40.09) = 7.53 dBuV/m

ANTENNA POLARITY : VERTICAL										
Frequency (MHz)	Level (dBuV/m)	Over Limit (dB)	Limit Line (dBuV/m)	Read Level (dBuV)	Antenna Factor (dB)	Cable Loss (dB)	Preamp Factor (dB)	Ant Pos (cm)	Table Pos (deg)	Remark
2483.50	49.16	-24.84	74.00	47.17	32.30	5.38	35.70	100	0	Peak
2483.50	9.07	-44.93	54.00	7.08	32.30	5.38	35.70	140	332	Average

Remark:

<Delta Marker>

Delta marker at 1% RBW of span = 47.09 dB

Peak band edge at 2483.50 MHz with RBW = VBW = 1MHz = 96.25 dBuV/m – 47.09 dB = 49.16 dBuV/m

Duty factor = 20 log (Package Transfer Times x Avg Hopping Channel) = 20 log (0.003 x 3.3) = -40.09

Average band edge = Peak band edge + Duty factor = 49.16 dBuV/m + (-40.09) = 9.07 dBuV/m



Test Mode :	Mode 4	Temperature :	26~28°C
Test Channel :	CH00_2402 MHz (2D Scanner with Battery 3600mAh)	Relative Humidity :	41~43%
Test Engineer :	Kay Wu		

ANTENNA POLARITY : HORIZONTAL										
Frequency (MHz)	Level (dBuV/m)	Over Limit (dB)	Limit Line (dBuV/m)	Read Level (dBuV)	Antenna Factor (dB)	Cable Loss (dB)	Preamp Factor (dB)	Ant Pos (cm)	Table Pos (deg)	Remark
2324.82	46.31	-27.69	74.00	44.13	32.33	5.51	35.67	100	0	Peak
2324.82	6.22	-47.78	54.00	4.04	32.33	5.51	35.67	100	172	Average

Remark:

<Delta Marker>

Delta marker at 1% RBW of span = 48.89 dB

Peak band edge at 2324.82 MHz with RBW = VBW = 1MHz = 95.2 dBuV/m – 48.89 dB = 46.31 dBuV/m

Duty factor = 20 log (Package Transfer Times x Avg Hopping Channel) = 20 log (0.003 x 3.3) = -40.09

Average band edge = Peak band edge + Duty factor = 46.31 dBuV/m + (-40.09) = 6.22 dBuV/m

ANTENNA POLARITY : VERTICAL										
Frequency (MHz)	Level (dBuV/m)	Over Limit (dB)	Limit Line (dBuV/m)	Read Level (dBuV)	Antenna Factor (dB)	Cable Loss (dB)	Preamp Factor (dB)	Ant Pos (cm)	Table Pos (deg)	Remark
2389.61	48.51	-25.49	74.00	46.43	32.30	5.46	35.68	100	0	Peak
2389.61	8.42	-45.58	54.00	6.34	32.30	5.46	35.68	100	306	Average

Remark:

<Delta Marker>

Delta marker at 1% RBW of span = 48.89 dB

Peak band edge at 2389.61 MHz with RBW = VBW = 1MHz = 97.4 dBuV/m – 48.89 dB = 48.51 dBuV/m

Duty factor = 20 log (Package Transfer Times x Avg Hopping Channel) = 20 log (0.003 x 3.3) = -40.09

Average band edge = Peak band edge + Duty factor = 48.51 dBuV/m + (-40.09) = 8.42 dBuV/m



Test Mode :	Mode 5	Temperature :	26~28°C
Test Channel :	CH78_2480 MHz (2D Scanner with Battery 3600mAh)	Relative Humidity :	41~43%
Test Engineer :	Kay Wu		

ANTENNA POLARITY : HORIZONTAL										
Frequency (MHz)	Level (dBuV/m)	Over Limit (dB)	Limit Line (dBuV/m)	Read Level (dBuV)	Antenna Factor (dB)	Cable Loss (dB)	Preamp Factor (dB)	Ant Pos (cm)	Table Pos (deg)	Remark
2483.50	44.94	-29.06	74.00	42.95	32.30	5.38	35.70	100	0	Peak
2483.50	4.85	-49.15	54.00	2.86	32.30	5.38	35.70	100	359	Average

Remark:

<Delta Marker>

Delta marker at 1% RBW of span = 47.09 dB

Peak band edge at 2483.50 MHz with RBW = VBW = 1MHz = 92.03 dBuV/m – 47.09 dB = 44.94 dBuV/m

Duty factor = 20 log (Package Transfer Times x Avg Hopping Channel) = 20 log (0.003 x 3.3) = -40.09

Average band edge = Peak band edge + Duty factor = 44.94 dBuV/m + (-40.09) = 4.85 dBuV/m

ANTENNA POLARITY : VERTICAL										
Frequency (MHz)	Level (dBuV/m)	Over Limit (dB)	Limit Line (dBuV/m)	Read Level (dBuV)	Antenna Factor (dB)	Cable Loss (dB)	Preamp Factor (dB)	Ant Pos (cm)	Table Pos (deg)	Remark
2483.50	48.63	-25.37	74.00	46.64	32.30	5.38	35.70	100	0	Peak
2483.50	8.54	-45.46	54.00	6.55	32.30	5.38	35.70	141	303	Average

Remark:

<Delta Marker>

Delta marker at 1% RBW of span = 47.09 dB

Peak band edge at 2483.50 MHz with RBW = VBW = 1MHz = 95.72 dBuV/m – 47.09 dB = 48.63 dBuV/m

Duty factor = 20 log (Package Transfer Times x Avg Hopping Channel) = 20 log (0.003 x 3.3) = -40.09

Average band edge = Peak band edge + Duty factor = 48.63 dBuV/m + (-40.09) = 8.54 dBuV/m



3.6.6 Test Result of Conducted Band Edges

Test Mode :	Mode 1, 3	Temperature :	26~27°C
Test Channel :	00, 78	Relative Humidity :	52~53%
Test Engineer :	Ken Hsu		

Low Band Edge Plot on Channel 00

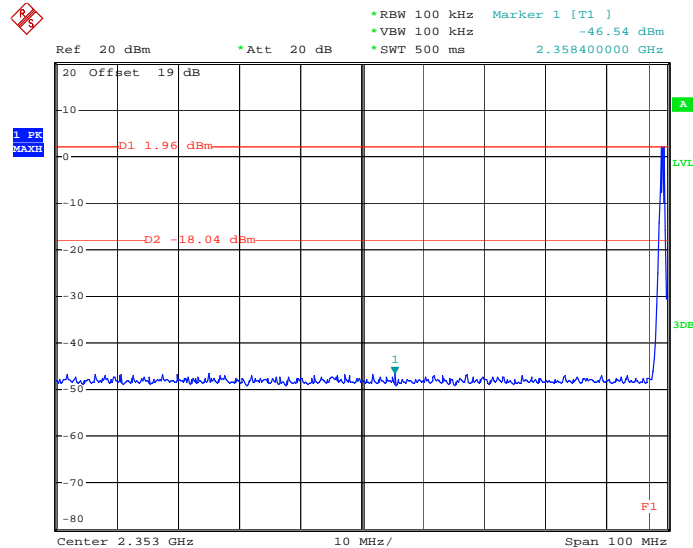

Date: 13.NOV.2008 20:22:57

High Band Edge Plot on Channel 78

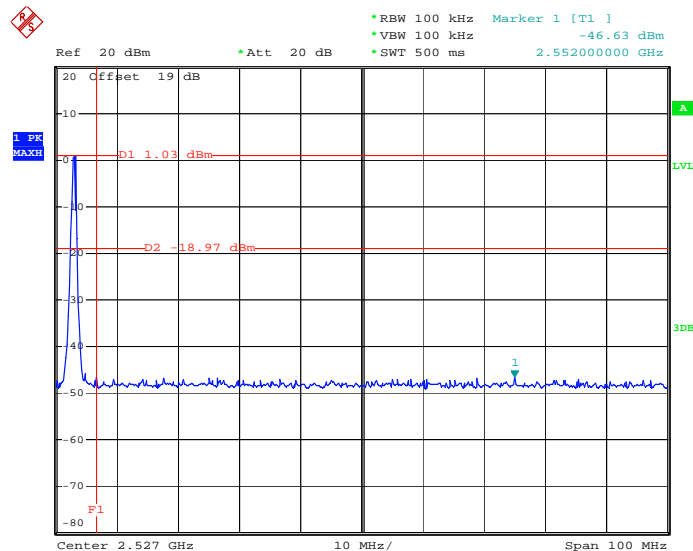

Date: 13.NOV.2008 20:28:01



Test Mode :	Mode 4, 6	Temperature :	26~27°C
Test Channel :	00, 78	Relative Humidity :	52~53%
Test Engineer :	Ken Hsu		

Low Band Edge Plot on Channel 00

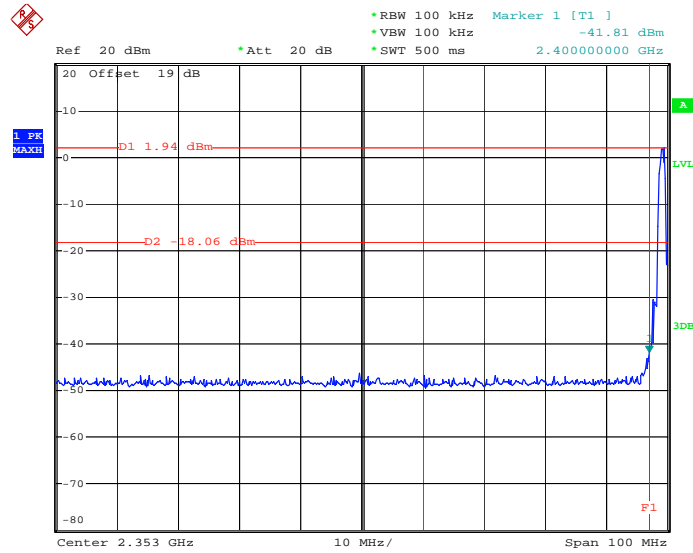

Date: 13.NOV.2008 20:24:15

High Band Edge Plot on Channel 78

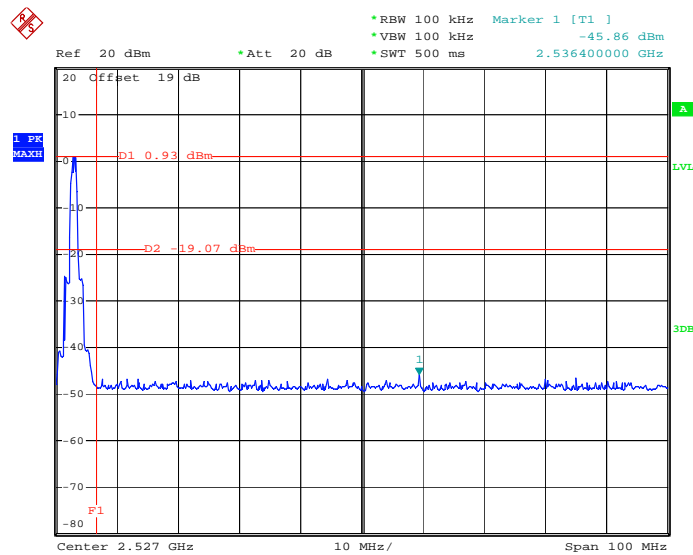

Date: 13.NOV.2008 20:29:22



Test Mode :	Mode 7, 9	Temperature :	26~27°C
Test Channel :	00, 78	Relative Humidity :	52~53%
Test Engineer :	Ken Hsu		

Low Band Edge Plot on Channel 00

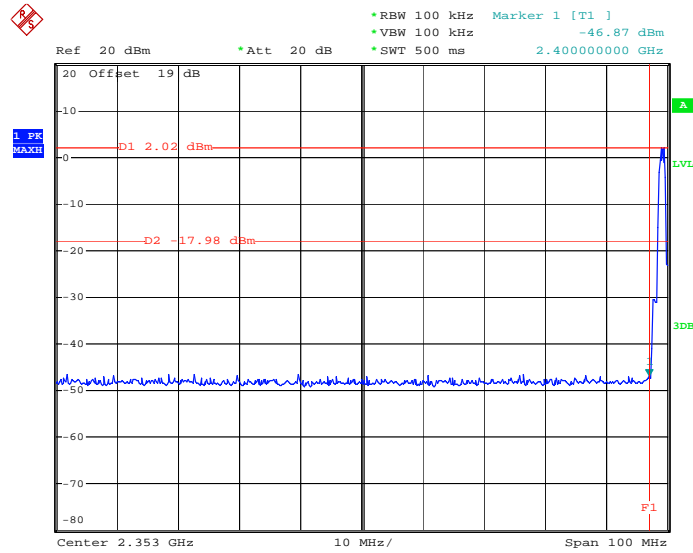

Date: 13.NOV.2008 20:25:51

High Band Edge Plot on Channel 78

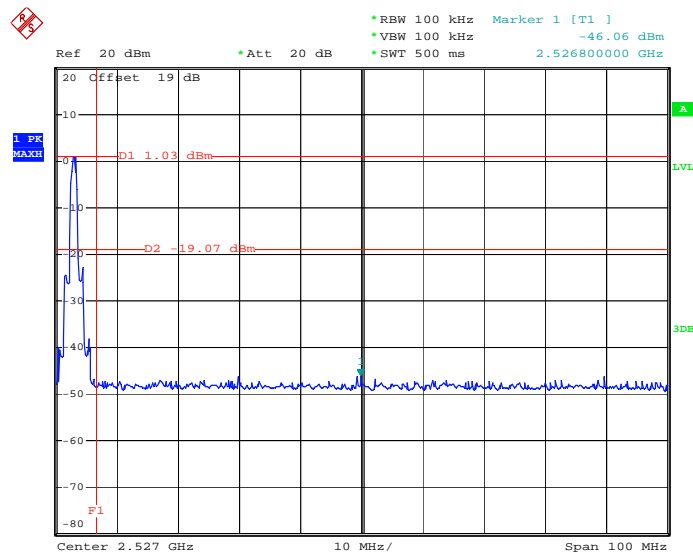

Date: 13.NOV.2008 20:30:44

3.7 AC Conducted Emission Measurement

3.7.1 Limit of AC Conducted Emission

For equipment that is designed to be connected to the public utility (AC) power line, the radio frequency voltage that is conducted back onto the AC power line on any frequency or frequencies within the band 150 kHz to 30 MHz shall not exceed the limits in the following table.

Frequency of emission (MHz)	Conducted limit (dBuV)	
	Quasi-peak	Average
0.15-0.5	66 to 56*	56 to 46*
0.5-5	56	46
5-30	60	50

*Decreases with the logarithm of the frequency.

3.7.2 Measuring Instruments

See list of measuring instruments of this test report.

3.7.3 Test Procedures

1. Please follow the guidelines in ANSI C63.4-2003.
2. The EUT was placed 0.4 meter from the conducting wall of the shielding room was kept at least 80 centimeters from any other grounded conducting surface.
3. Connect EUT to the power mains through a line impedance stabilization network (LISN).
4. All the support units are connecting to the other LISN.
5. The LISN provides 50 ohm coupling impedance for the measuring instrument.
6. The FCC states that a 50 ohm, 50 microhenry LISN should be used.
7. Both sides of AC line were checked for maximum conducted interference.
8. The frequency range from 150 kHz to 30 MHz was searched.
9. Set the test-receiver system to Peak Detect Function and specified bandwidth with Maximum Hold Mode.

3.7.4 Test Setup

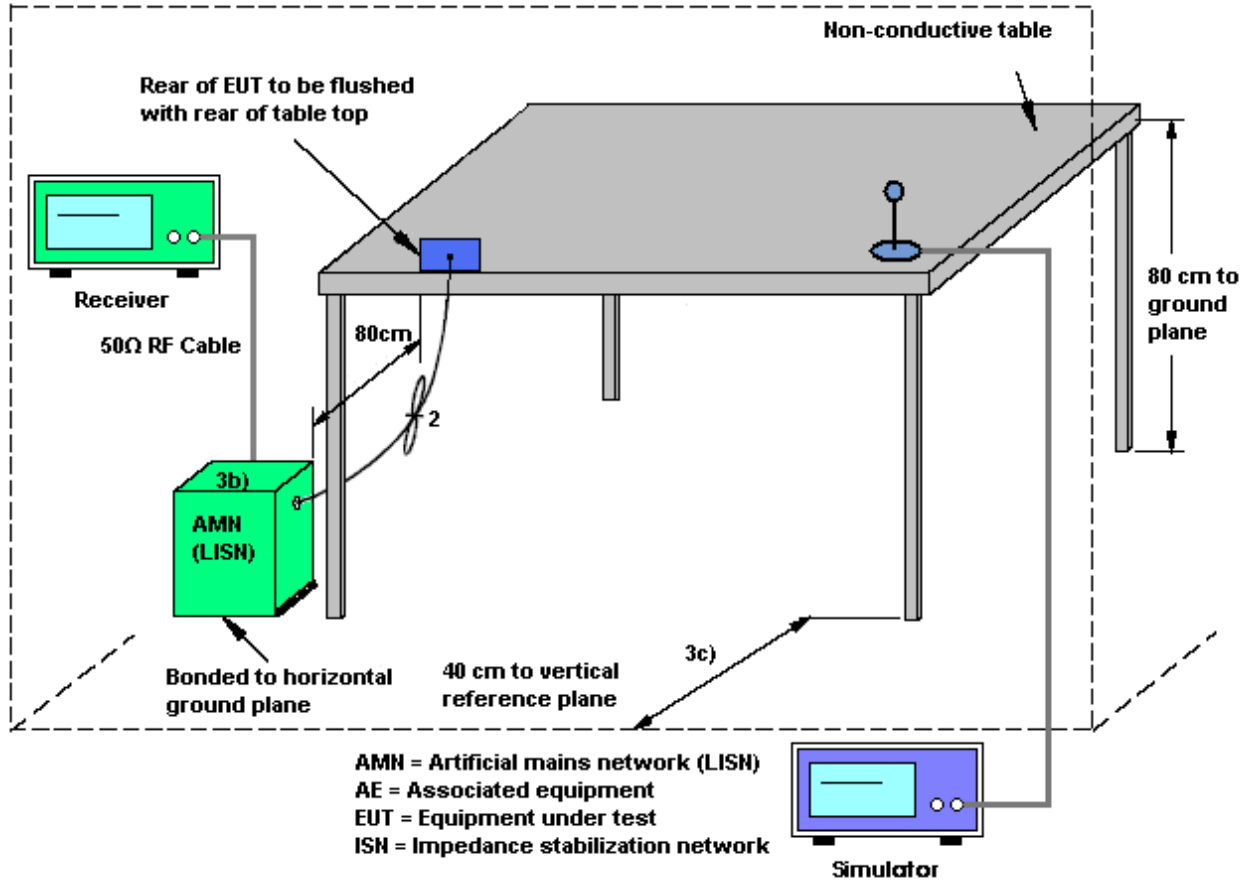

3.7.5 Test Result of AC Conducted Emission

Test Mode :	Mode 1	Temperature :	26~27°C
Test Engineer :	Cona Huang	Relative Humidity :	52~53%
		Phase :	Line
Function Type :	GSM850 Idle + GPS Rx + BT Link + USB Charging Cable with AC power + USB Link + MPEG4 + 1D Scanner + Numeric Keypad + Battery 2 (3600mAh)		
Remark :	All emissions not reported here are more than 10 dB below the prescribed limit.		

ENV216 Auto Test

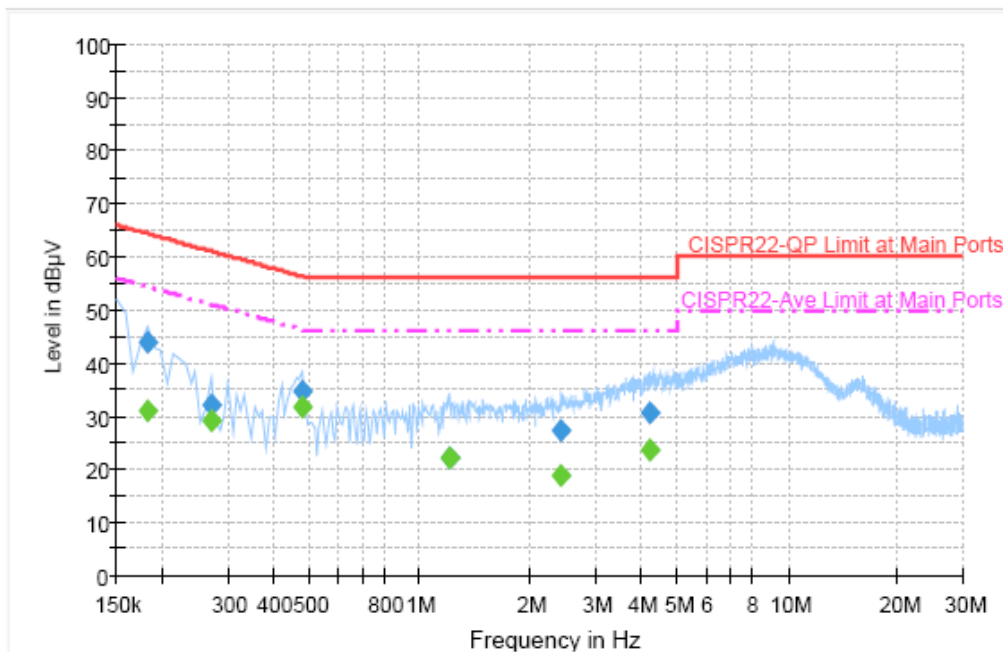

Final Result 1

Frequency (MHz)	QuasiPeak (dBµV)	Filter	Line	Corr. (dB)	Margin (dB)	Limit (dBµV)
0.182000	43.9	Off	L1	19.4	20.5	64.4
0.270000	32.1	Off	L1	19.3	29.0	61.1
0.478000	34.7	Off	L1	19.4	21.7	56.4
1.206000	22.2	Off	L1	19.4	33.8	56.0
2.430000	27.5	Off	L1	19.5	28.5	56.0
4.206000	30.6	Off	L1	19.5	25.4	56.0

Final Result 2

Frequency (MHz)	Average (dBµV)	Filter	Line	Corr. (dB)	Margin (dB)	Limit (dBµV)
0.182000	30.8	Off	L1	19.4	23.6	54.4
0.270000	29.0	Off	L1	19.3	22.1	51.1
0.478000	31.9	Off	L1	19.4	14.5	46.4
1.206000	22.1	Off	L1	19.4	23.9	46.0
2.430000	19.0	Off	L1	19.5	27.0	46.0
4.206000	23.5	Off	L1	19.5	22.5	46.0

Test Mode :	Mode 1	Temperature :	26~27°C
Test Engineer :	Cona Huang	Relative Humidity :	52~53%
		Phase :	Neutral
Function Type :	GSM850 Idle + GPS Rx + BT Link + USB Charging Cable with AC power + USB Link + MPEG4 + 1D Scanner + Numeric Keypad + Battery 2 (3600mAh)		
Remark :	All emissions not reported here are more than 10 dB below the prescribed limit.		

ENV216 Auto Test

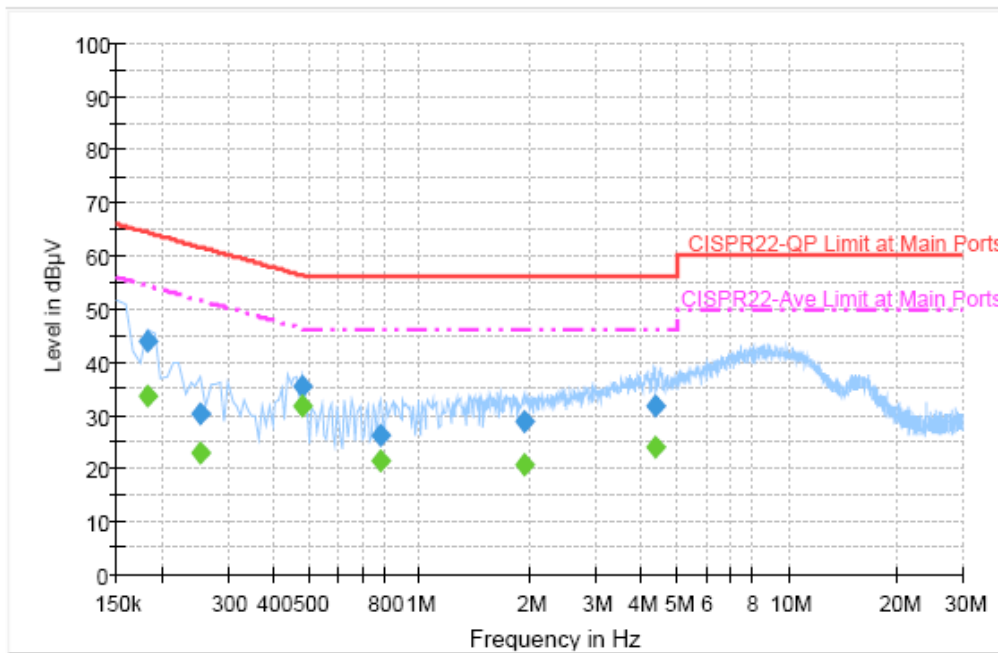

Final Result 1

Frequency (MHz)	QuasiPeak (dBµV)	Filter	Line	Corr. (dB)	Margin (dB)	Limit (dBµV)
0.182000	44.0	Off	N	19.4	20.4	64.4
0.254000	30.3	Off	N	19.4	31.3	61.6
0.478000	35.6	Off	N	19.4	20.8	56.4
0.782000	26.0	Off	N	19.4	30.0	56.0
1.918000	28.7	Off	N	19.5	27.3	56.0
4.382000	31.7	Off	N	19.5	24.3	56.0

Final Result 2

Frequency (MHz)	Average (dBµV)	Filter	Line	Corr. (dB)	Margin (dB)	Limit (dBµV)
0.182000	33.5	Off	N	19.4	21.0	54.4
0.254000	22.7	Off	N	19.4	28.9	51.6
0.478000	31.7	Off	N	19.4	14.7	46.4
0.782000	21.3	Off	N	19.4	24.7	46.0
1.918000	20.5	Off	N	19.5	25.5	46.0
4.382000	24.1	Off	N	19.5	21.9	46.0

Test Mode :	Mode 2	Temperature :	26~27°C
Test Engineer :	Cona Huang	Relative Humidity :	52~53%
		Phase :	Line
Function Type :	GSM850 Idle + GPS Rx + BT Link + USB Charging Cable with AC power + USB Link + Camera + 2D Scanner + Qwerty Keypad + Battery 1 (2400mAh)		
Remark :	All emissions not reported here are more than 10 dB below the prescribed limit.		

ENV216 Auto Test

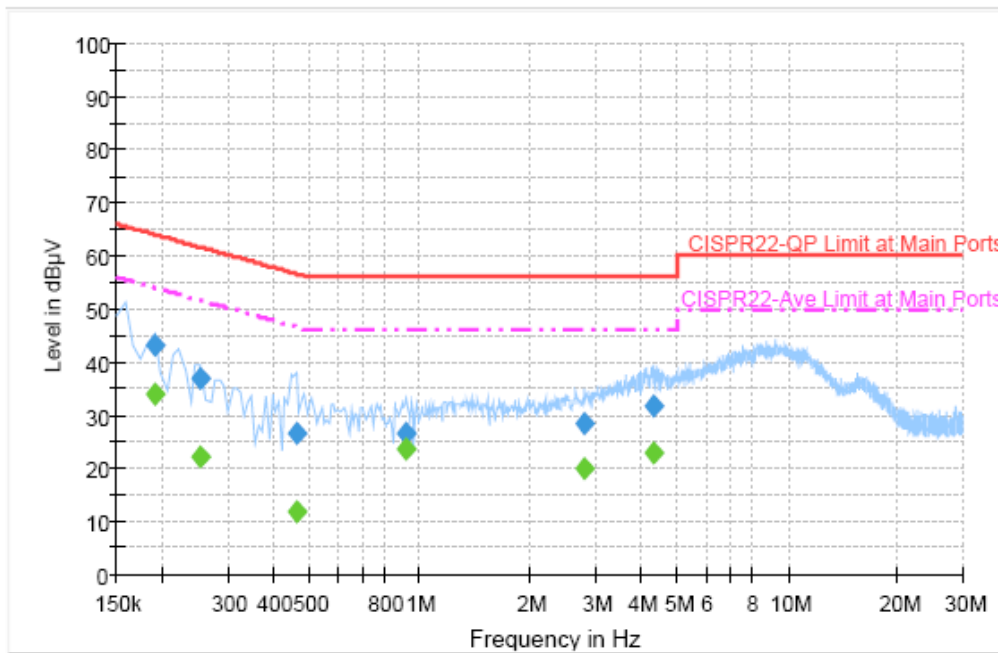

Final Result 1

Frequency (MHz)	QuasiPeak (dBµV)	Filter	Line	Corr. (dB)	Margin (dB)	Limit (dBµV)
0.190000	43.1	Off	L1	19.4	20.9	64.0
0.254000	37.0	Off	L1	19.3	24.6	61.6
0.462000	26.7	Off	L1	19.3	30.0	56.7
0.918000	26.6	Off	L1	19.4	29.4	56.0
2.806000	28.5	Off	L1	19.5	27.5	56.0
4.326000	31.9	Off	L1	19.5	24.1	56.0

Final Result 2

Frequency (MHz)	Average (dBµV)	Filter	Line	Corr. (dB)	Margin (dB)	Limit (dBµV)
0.190000	33.9	Off	L1	19.4	20.1	54.0
0.254000	22.3	Off	L1	19.3	29.3	51.6
0.462000	11.9	Off	L1	19.3	34.8	46.7
0.918000	23.6	Off	L1	19.4	22.4	46.0
2.806000	20.1	Off	L1	19.5	25.9	46.0
4.326000	23.0	Off	L1	19.5	23.0	46.0

Test Mode :	Mode 2	Temperature :	26~27°C
Test Engineer :	Cona Huang	Relative Humidity :	52~53%
		Phase :	Neutral
Function Type :	GSM850 Idle + GPS Rx + BT Link + USB Charging Cable with AC power + USB Link + Camera + 2D Scanner + Qwerty Keypad + Battery 1 (2400mAh)		
Remark :	All emissions not reported here are more than 10 dB below the prescribed limit.		

ENV216 Auto Test

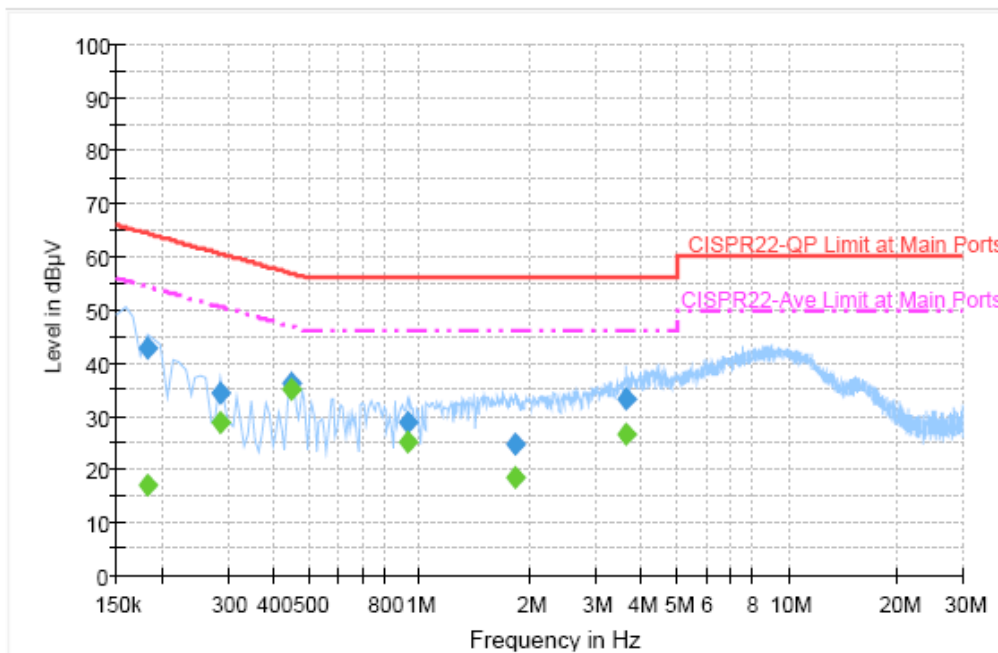

Final Result 1

Frequency (MHz)	QuasiPeak (dBµV)	Filter	Line	Corr. (dB)	Margin (dB)	Limit (dBµV)
0.182000	42.8	Off	N	19.4	21.6	64.4
0.286000	34.5	Off	N	19.3	26.1	60.6
0.446000	36.0	Off	N	19.3	20.9	56.9
0.926000	28.9	Off	N	19.4	27.1	56.0
1.822000	24.6	Off	N	19.5	31.4	56.0
3.638000	33.0	Off	N	19.5	23.0	56.0

Final Result 2

Frequency (MHz)	Average (dBµV)	Filter	Line	Corr. (dB)	Margin (dB)	Limit (dBµV)
0.182000	16.8	Off	N	19.4	37.6	54.4
0.286000	28.6	Off	N	19.3	22.0	50.6
0.446000	35.1	Off	N	19.3	11.8	46.9
0.926000	25.1	Off	N	19.4	20.9	46.0
1.822000	18.4	Off	N	19.5	27.6	46.0
3.638000	26.4	Off	N	19.5	19.6	46.0

3.8 Radiated Emission Measurement

3.8.1 Limit of Radiated Emission

In any 100 kHz bandwidth outside the intentional radiator frequency band, all harmonics/spurious must be at least 20 dB below the highest emission level within the authorized band. In addition, radiated emissions which fall in the restricted bands must also comply with the FCC section 15.209 limits as below.

Frequency (MHz)	Field Strength (microvolts/meter)	Measurement Distance (meters)
0.009 – 0.490	2400/F(kHz)	300
0.490 – 1.705	24000/F(kHz)	30
1.705 – 30.0	30	30
30 – 88	100	3
88 – 216	150	3
216 - 960	200	3
Above 960	500	3

3.8.2 Measuring Instruments

See list of measuring instruments of this test report.

3.8.3 Test Procedures

1. The testing follows the guidelines in FCC Public Notice DA 00-705 Measurement Guidelines.
2. Use the following spectrum analyzer settings:
Span = wide enough to fully capture the emission being measured; RBW = 1 MHz for $f \geq 1$ GHz, 100 kHz for $f < 1$ GHz; VBW \geq RBW; Sweep = auto; Detector function = peak; Trace = max hold.
3. Follow the guidelines in ANSI C63.4-2003 with respect to maximizing the emission by rotating the EUT, measuring the emission for three EUT orthogonal planes, and adjusting the measurement antenna height and polarization. A pre-amp and a high pass filter are used for this test in order to get the good signal level.

3.8.4 Test Setup

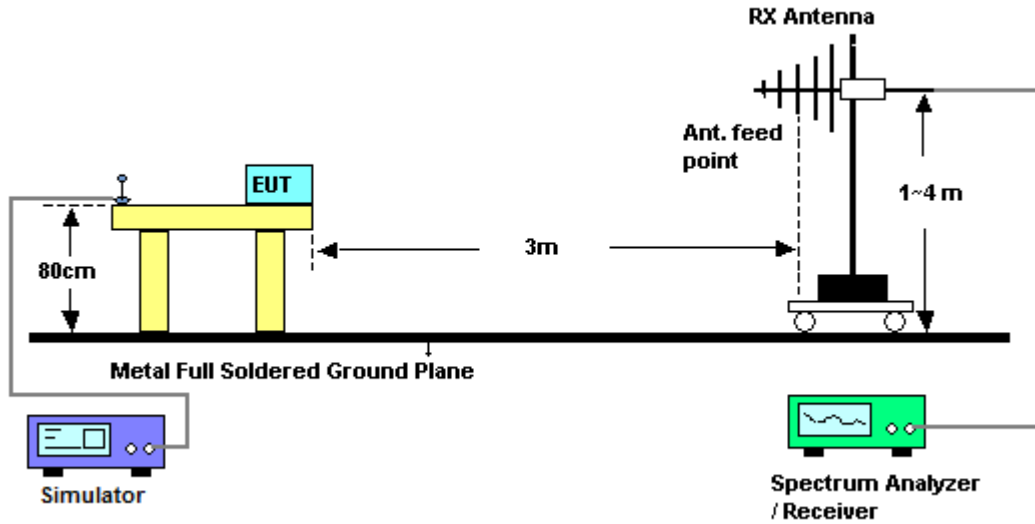



3.8.5 Test Result of Radiated Emission < 1GHz

Test Mode :	Mode 1	Temperature :	26~28°C
Test Channel :	CH00_2402 MHz (1D Scanner with Battery 3600mAh)	Relative Humidity :	41~43%
Test Engineer :	Kay Wu	Polarization :	Horizontal
Remark :			

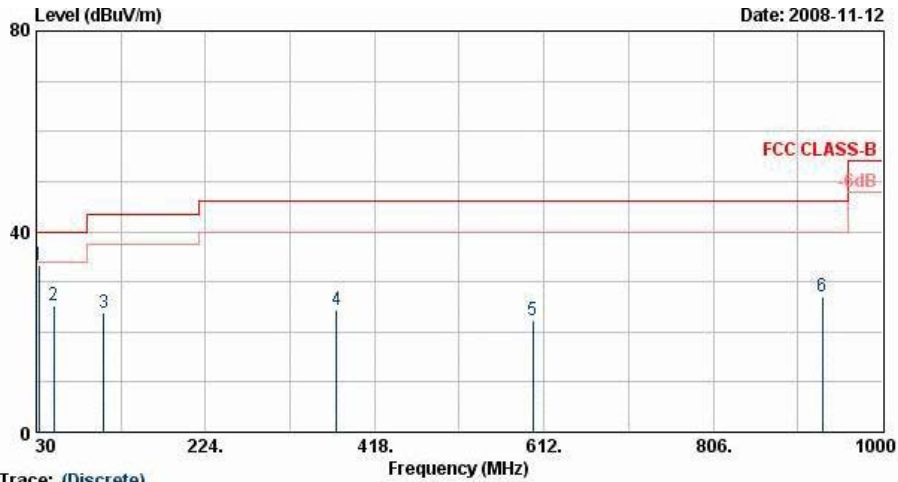

Trace: (Discrete)
 Site : 03CH07-HY
 Condition : 3m LF-ANT(080228) HORIZONTAL
 Model : FR 802928
 Mode : Mode 1
 Plane : H

	Freq	Level	Over Limit	Limit Line	ReadAntenna	Cable	Preamp	Ant	Table	Remark
	MHz	dBuV/m	dB	dBuV/m	dBuV	dB/m	dB	dB	cm	deg
1	32.97	33.27	-6.73	40.00	47.07	16.76	0.66	31.23	100	0 QP
2	50.25	25.41	-14.59	40.00	47.62	8.18	0.83	31.22	---	---
3	107.22	23.88	-19.62	43.50	43.59	10.49	1.21	31.40	---	---
4	374.20	24.49	-21.51	46.00	38.31	15.05	2.47	31.34	---	---
5	598.90	22.31	-23.69	46.00	30.31	19.73	3.24	30.98	---	---
6	931.40	27.03	-18.97	46.00	29.74	23.73	4.22	30.66	---	---



Test Mode :	Mode 1	Temperature :	26~28°C
Test Channel :	CH00_2402 MHz (1D Scanner with Battery 3600mAh)	Relative Humidity :	41~43%
Test Engineer :	Kay Wu	Polarization :	Vertical
Remark :			

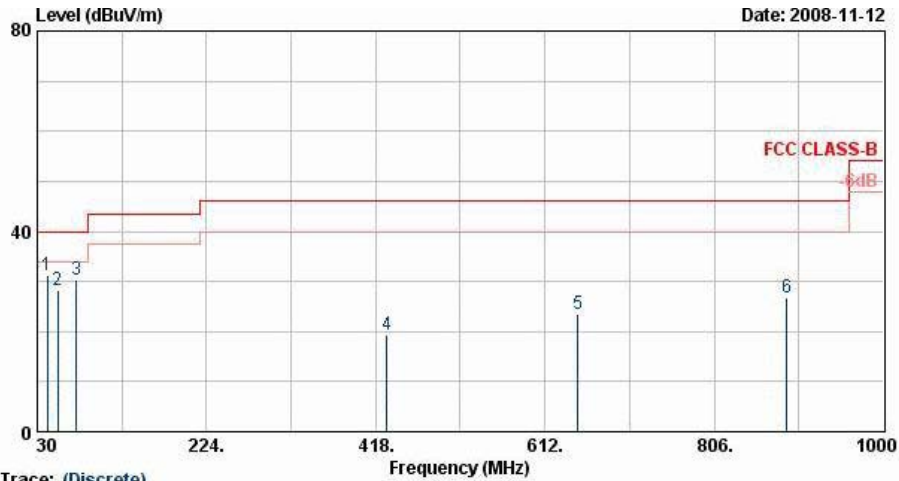

Trace: (Discrete)

Site : 03CH07-HY
 Condition : 3m LF-ANT(080228) VERTICAL
 Model : FR 8O2928
 Mode : Mode 1
 Plane : H

	Freq	Level	Over Limit	Limit Line	ReadAntenna Level	Antenna Factor	Cable Loss	Preamp Factor	Ant Pos	Table Pos	Remark
	MHz	dBuV/m	dB	dBuV/m	dBuV	dB/m	dB	dB	cm	deg	
1	41.34	31.12	-8.88	40.00	49.10	12.46	0.73	31.17	100	307	QP
2	53.22	28.26	-11.74	40.00	51.20	7.49	0.85	31.28	100	307	QP
3	74.82	30.35	-9.65	40.00	53.98	6.75	0.98	31.36	---	---	QP
4	430.90	19.40	-26.60	46.00	31.55	16.43	2.73	31.30	---	---	QP
5	649.30	23.64	-22.36	46.00	31.07	20.05	3.41	30.89	---	---	QP
6	889.40	26.70	-19.30	46.00	29.97	23.16	4.12	30.54	---	---	QP



Test Mode :	Mode 2	Temperature :	26~28°C
Test Channel :	CH39_2441 MHz (1D Scanner with Battery 3600mAh)	Relative Humidity :	41~43%
Test Engineer :	Kay Wu	Polarization :	Horizontal
Remark :			

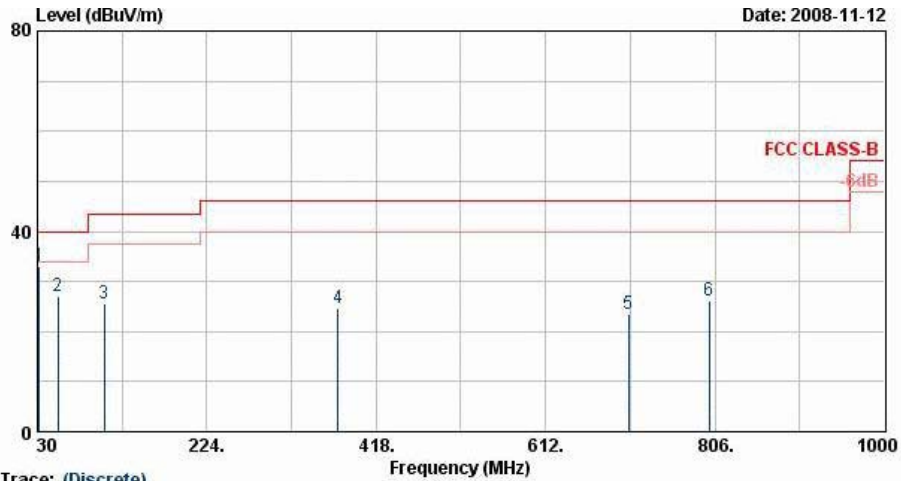

Trace: (Discrete)
 Site : 03CH07-HY
 Condition : 3m LF-ANT(080228) HORIZONTAL
 Model : FR 8O2928
 Mode : Mode 2
 Plane : H

	Freq	Level	Over	Limit	ReadAntenna	Cable	Preamp	Ant	Table	Remark
	MHz	dBuV/m	dB	dBuV/m	dBuV	dB	dB	cm	deg	
1	31.89	32.88	-7.12	40.00	46.11	17.38	0.66	31.26	100	0 QP
2	53.22	26.98	-13.02	40.00	49.91	7.49	0.85	31.28	---	---
3	106.41	25.68	-17.82	43.50	45.46	10.42	1.20	31.40	---	---
4	374.20	24.65	-21.35	46.00	38.46	15.05	2.47	31.34	---	---
5	707.40	23.35	-22.65	46.00	30.25	20.46	3.57	30.93	---	---
6	799.80	26.20	-19.80	46.00	30.99	22.12	3.85	30.76	---	---



Test Mode :	Mode 2	Temperature :	26~28°C
Test Channel :	CH39_2441 MHz (1D Scanner with Battery 3600mAh)	Relative Humidity :	41~43%
Test Engineer :	Kay Wu	Polarization :	Vertical
Remark :			

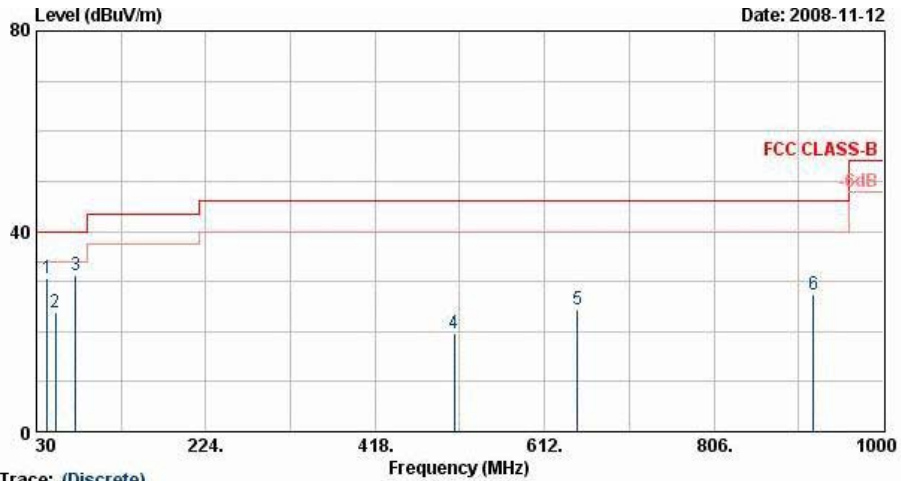

Trace: (Discrete)

Site : 03CH07-HY
 Condition : 3m LF-ANT(080228) VERTICAL
 Model : FR 802928
 Mode : Mode 2
 Plane : H

	Freq	Level	Over	Limit	ReadAntenna	Cable	Preamp	Ant	Table	Remark
	MHz	dBuV/m	dB	dBuV/m	dBuV	dB/m	dB	dB	cm	deg
1	42.69	30.72	-9.28	40.00	49.26	11.92	0.72	31.18	100	300 QP
2	52.14	23.92	-16.08	40.00	46.61	7.72	0.85	31.26	100	300 QP
3	75.09	31.11	-8.89	40.00	54.73	6.75	0.98	31.36	---	---
4	508.60	19.56	-26.44	46.00	29.61	18.07	2.96	31.09	---	---
5	649.30	24.43	-21.57	46.00	31.87	20.05	3.41	30.89	---	---
6	920.20	27.47	-18.53	46.00	30.31	23.58	4.20	30.61	---	---



Test Mode :	Mode 3	Temperature :	26~28°C
Test Channel :	CH78_2480 MHz (1D Scanner with Battery 3600mAh)	Relative Humidity :	41~43%
Test Engineer :	Kay Wu	Polarization :	Horizontal
Remark :			

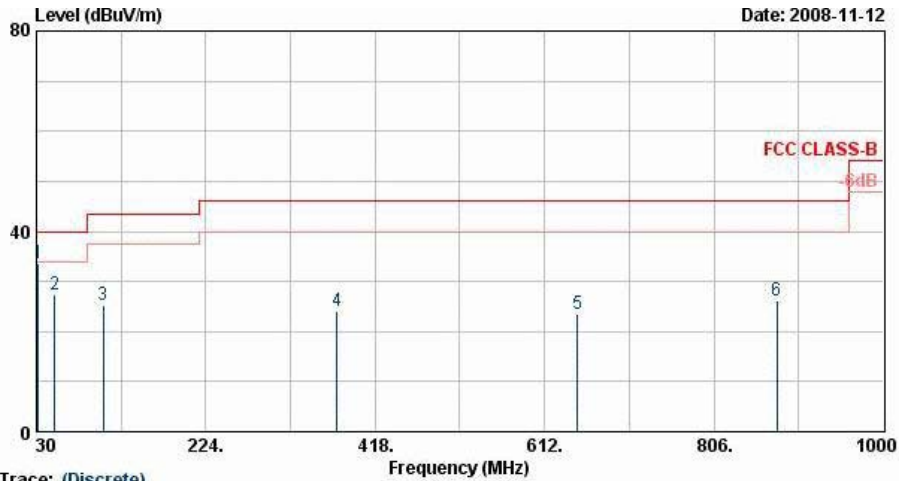

Trace: (Discrete)
 Site : 03CH07-HY
 Condition : 3m LF-ANT(080228) HORIZONTAL
 Model : FR 8O2928
 Mode : Mode 3
 Plane : H

	Freq	Level	Over	Limit	Read	Antenna	Cable	Preamp	Ant	Table	Remark
	MHz	dBuV/m	dB	dBuV/m	dBuV	dB/m	dB	dB	cm	deg	
1	32.16	33.47	-6.53	40.00	46.69	17.38	0.66	31.26	100	0	QP
2	51.33	27.34	-12.66	40.00	49.80	7.95	0.84	31.24	---	---	QP
3	106.41	25.27	-18.23	43.50	45.05	10.42	1.20	31.40	---	---	QP
4	374.20	24.01	-21.99	46.00	37.83	15.05	2.47	31.34	---	---	QP
5	649.30	23.40	-22.60	46.00	30.84	20.05	3.41	30.89	---	---	QP
6	878.20	26.22	-19.78	46.00	29.70	23.02	4.07	30.57	---	---	QP



Test Mode :	Mode 3	Temperature :	26~28°C
Test Channel :	CH78_2480 MHz (1D Scanner with Battery 3600mAh)	Relative Humidity :	41~43%
Test Engineer :	Kay Wu	Polarization :	Vertical
Remark :			

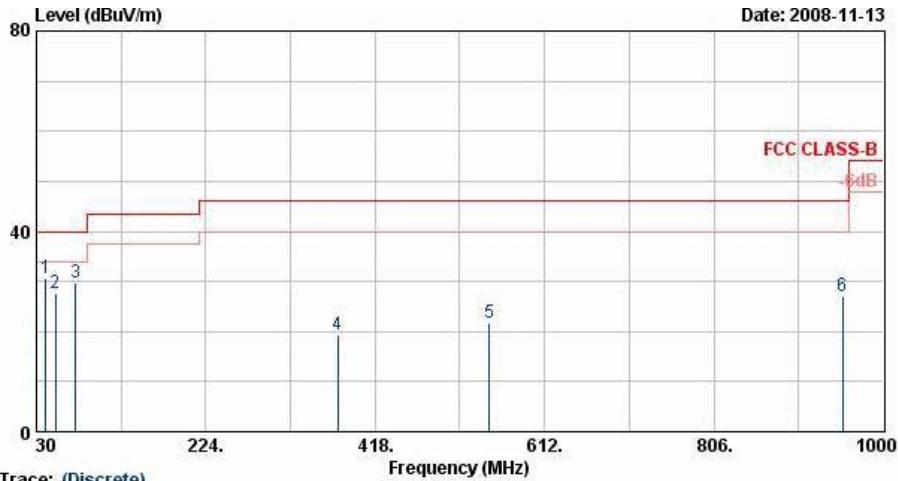

Trace: (Discrete)
 Site : 03CH07-HY
 Condition : 3m LF-ANT(080228) VERTICAL
 Model : FR 802928
 Mode : Mode 3
 Plane : H

	Freq	Level	Over	Limit	Read	Antenna	Cable	Preamp	Ant	Table	Remark
	MHz	dBuV/m	Limit	Line	Level	Factor	Loss	Factor	Pos	Pos	
			dB	dBuV/m	dBuV	dB/m	dB	dB	cm	deg	
1	40.53	30.71	-9.29	40.00	48.12	13.01	0.73	31.15	100	311	QP
2	52.14	27.63	-12.37	40.00	50.32	7.72	0.85	31.26	100	311	QP
3	75.09	29.70	-10.30	40.00	53.33	6.75	0.98	31.36	---	---	QP
4	374.90	19.32	-26.68	46.00	33.10	15.08	2.47	31.33	---	---	QP
5	548.50	21.57	-24.43	46.00	30.69	18.82	3.09	31.03	---	---	QP
6	953.80	27.16	-18.84	46.00	29.56	24.06	4.27	30.73	---	---	QP



3.8.6 Test Result of Radiated Emission ≥ 1 GHz

Test Mode :	Mode 1	Temperature :	26~28°C
Test Channel :	CH00_2402 MHz (1D Scanner with Battery 3600mAh)	Relative Humidity :	41~43%
Test Engineer :	Kay Wu	Polarization :	Horizontal
Remark :	#3 and #4 are Fundamental Signals		

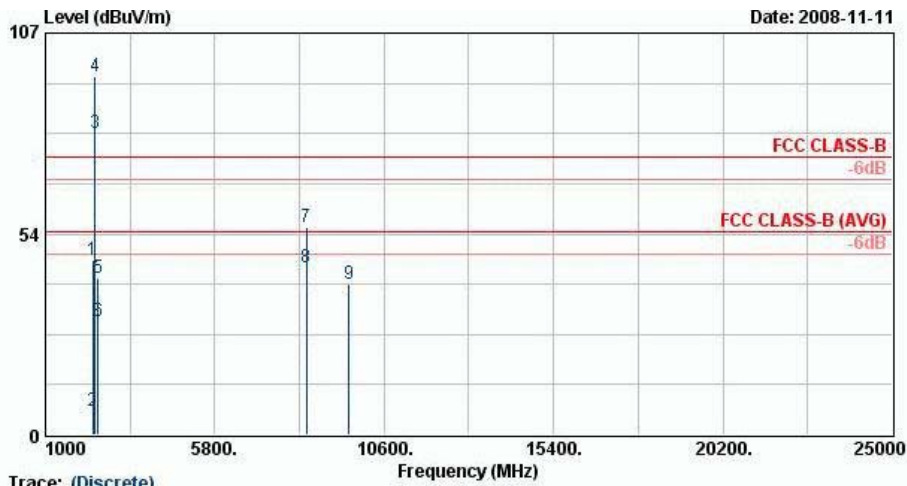

Trace: (Discrete)
 Site : 03CH07-HY
 Condition : 3m SHF-EHF HORN HORIZONTAL
 Model : FR 802928
 Mode : Mode 1
 Plane : H

	Freq	Level	Over	Limit	Read	Antenna	Cable	Preamp	Ant	Table	Remark
	MHz	dBuV/m	Limit	Line	Level	Factor	Loss	Factor	Pos	Pos	
			dB	dBuV/m	dBuV	dB/m	dB	dB	cm	deg	
1	2341.54	46.48	-27.52	74.00	44.32	32.33	5.50	35.67	100	0	Peak
2	2341.54	6.39	-47.61	54.00	4.23	32.33	5.50	35.67	100	171	Average
3 X	2402.00	80.26			78.16	32.32	5.46	35.68	100	171	Average
4 X	2402.00	95.37			93.29	32.32	5.44	35.68	100	0	Peak
5	2483.50	41.61	-32.39	74.00	39.62	32.30	5.38	35.70	100	0	Peak
6	2483.50	30.31	-23.69	54.00	28.32	32.30	5.38	35.70	100	171	Average
7	8406.00	55.27	-18.73	74.00	43.06	38.38	10.12	36.30	100	0	Peak
8	8406.00	44.54	-9.46	54.00	32.34	38.38	10.12	36.30	100	74	Average
9	9606.00	40.17	-33.83	74.00	76.34	-10.16	10.71	36.72	100	0	Peak



Test Mode :	Mode 1	Temperature :	26~28°C
Test Channel :	CH00_2402 MHz (1D Scanner with Battery 3600mAh)	Relative Humidity :	41~43%
Test Engineer :	Kay Wu	Polarization :	Vertical
Remark :	#3 and #4 are Fundamental Signals		

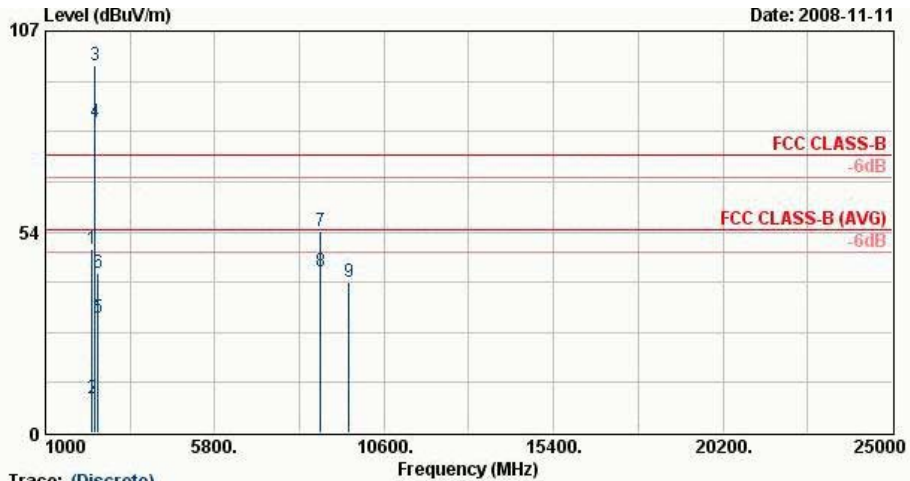

Trace: (Discrete)
 Site : 03CH07-HY
 Condition : 3m SHF-EHF HORN VERTICAL
 Model : FR 802928
 Mode : Mode 1
 Plane : H

	Freq	Level	Over	Limit	Read	Antenna	Cable	Preamp	Ant	Table	
	MHz	dBuV/m	dB	dBuV/m	Level	Factor	Loss	Factor	Pos	Pos	Remark
					dBuV	dB/m	dB	dB	cm	deg	
1	2330.14	49.08	-24.92	74.00	46.93	32.30	5.51	35.67	100	0	Peak
2	2330.14	8.99	-45.01	54.00	6.84	32.30	5.51	35.67	177	312	Average
3 X	2402.00	97.97			95.91	32.30	5.44	35.68	100	0	Peak
4 @	2402.00	82.56			80.48	32.30	5.46	35.68	177	312	Average
5	2483.50	30.47	-23.53	54.00	28.48	32.30	5.38	35.70	177	312	Average
6	2483.50	42.49	-31.51	74.00	40.50	32.30	5.38	35.70	100	0	Peak
7	8802.00	53.69	-20.31	74.00	42.42	37.48	10.28	36.48	100	0	Peak
8	8802.00	42.86	-11.14	54.00	31.58	37.48	10.28	36.48	100	65	Average
9	9606.00	39.99	-34.01	74.00	76.17	-10.16	10.71	36.72	100	0	Peak



Test Mode :	Mode 2	Temperature :	26~28°C
Test Channel :	CH39_2441 MHz (1D Scanner with Battery 3600mAh)	Relative Humidity :	41~43%
Test Engineer :	Kay Wu	Polarization :	Horizontal
Remark :	#3 and #4 are Fundamental Signals		

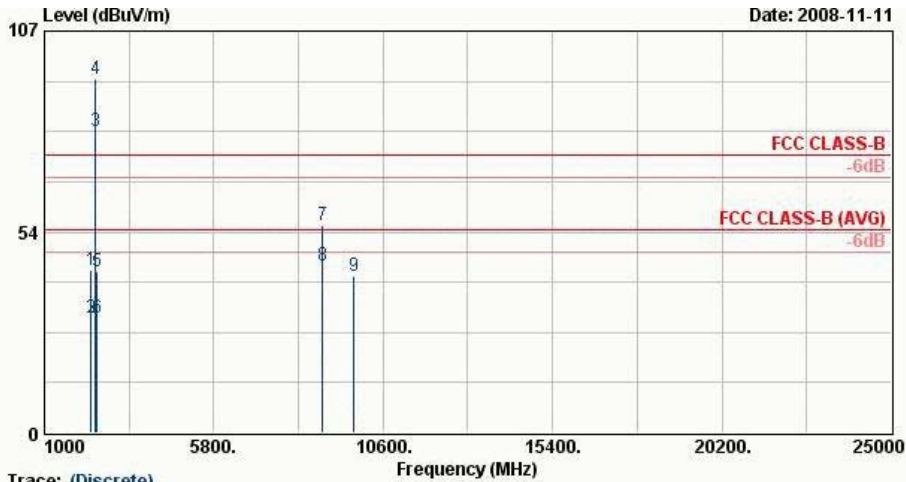

Trace: (Discrete)
 Site : 03CHO7-HY
 Condition : 3m SHF-EHF HORN HORIZONTAL
 Model : FR 8O2928
 Mode : Mode 2
 Plane : H

	Freq	Level	Over	Limit	Read	Antenna	Cable	Preamp	Ant	Table	Remark
	MHz	dBuV/m	Limit	Line	Level	Factor	Loss	Factor	Pos	Pos	
			dB	dBuV/m	dBuV	dB/m	dB	dB	cm	deg	
1	2316.00	43.27	-30.73	74.00	41.07	32.34	5.53	35.67	100	0	Peak
2	2316.00	30.57	-23.43	54.00	28.37	32.34	5.53	35.67	119	55	Average
3 X	2441.00	80.31			78.28	32.31	5.41	35.69	119	55	Average
4 X	2441.00	94.38			92.34	32.31	5.41	35.69	100	0	Peak
5	2483.50	42.77	-31.23	74.00	40.78	32.30	5.38	35.70	100	0	Peak
6	2483.50	30.49	-23.51	54.00	28.50	32.30	5.38	35.70	119	55	Average
7	8886.00	55.35	-18.65	74.00	42.95	38.63	10.30	36.53	100	0	Peak
8	8886.00	44.39	-9.61	54.00	31.98	38.63	10.30	36.53	100	17	Average
9	9762.00	41.85	-32.15	74.00	77.61	-9.83	10.82	36.76	100	0	Peak



Test Mode :	Mode 2	Temperature :	26~28°C
Test Channel :	CH39_2441 MHz (1D Scanner with Battery 3600mAh)	Relative Humidity :	41~43%
Test Engineer :	Kay Wu	Polarization :	Vertical
Remark :	#3 and #4 are Fundamental Signals		

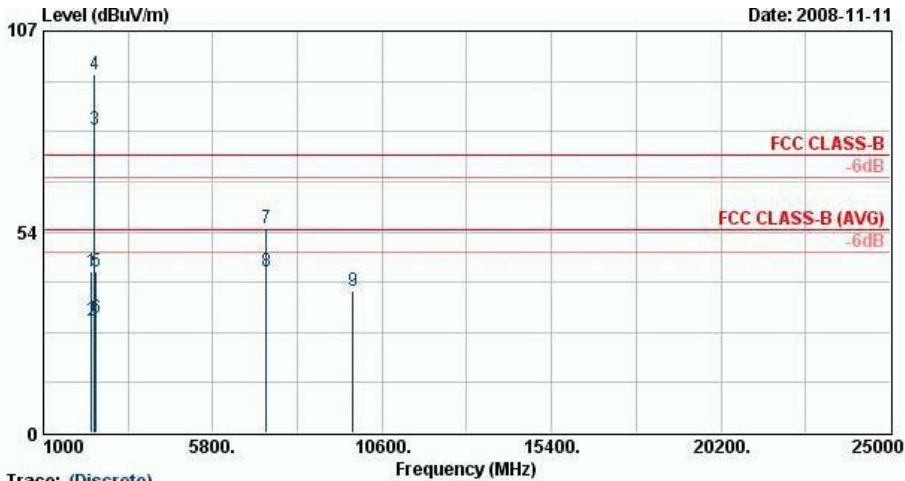

Site : 03CHO7-HY
 Condition : 3m SHF-EHF HORN VERTICAL
 Model : FR 8O2928
 Mode : Mode 2
 Plane : H

	Freq	Level	Over	Limit	ReadAntenna	Cable	Preamp	Ant	Table	
	MHz	dBuV/m	dB	dBuV/m	Level	Loss	Factor	Pos	Pos	Remark
					Factor			cm	deg	
1	2364.00	42.86	-31.14	74.00	40.75	32.30	5.49	35.67	100	0 Peak
2	2364.00	29.93	-24.07	54.00	27.81	32.30	5.49	35.67	100	304 Average
3 @	2441.00	80.79			78.77	32.30	5.41	35.69	100	304 Average
4 X	2441.00	95.35			93.33	32.30	5.41	35.69	100	0 Peak
5	2483.50	42.95	-31.05	74.00	40.96	32.30	5.38	35.70	100	0 Peak
6	2483.50	30.60	-23.40	54.00	28.61	32.30	5.38	35.70	100	304 Average
7	7326.00	54.31	-19.69	74.00	43.91	36.73	9.80	36.13	100	0 Peak
8	7326.00	42.87	-11.13	54.00	32.47	36.73	9.80	36.13	100	275 Average
9	9762.00	37.98	-36.02	74.00	73.74	-9.83	10.82	36.76	100	0 Peak



Test Mode :	Mode 3	Temperature :	26~28°C
Test Channel :	CH78_2480 MHz (1D Scanner with Battery 3600mAh)	Relative Humidity :	41~43%
Test Engineer :	Kay Wu	Polarization :	Horizontal
Remark :	#3 and #4 are Fundamental Signals		

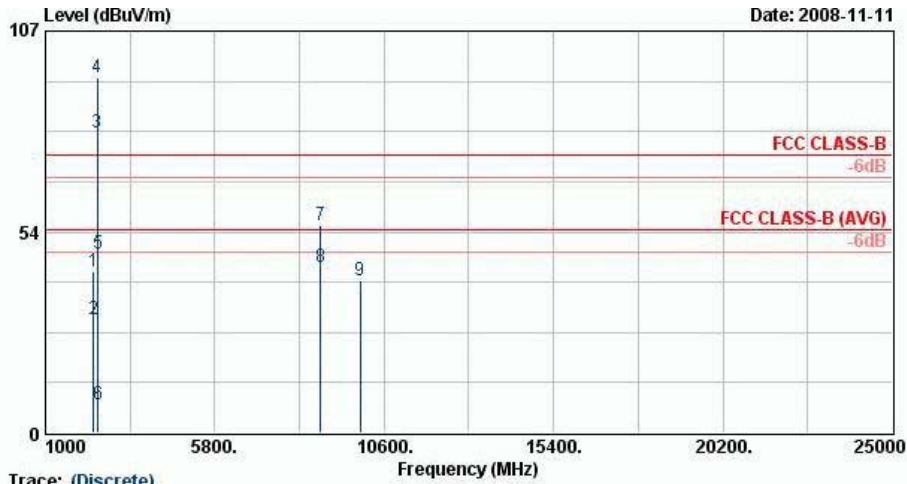

Trace: (Discrete)

Site : 03CH07-HY
 Condition : 3m SHF-EHF HORN HORIZONTAL
 Model : FR 8O2928
 Mode : Mode 3
 Plane : H

	Freq	Level	Over	Limit	Read	Antenna	Cable	Preamp	Ant	Table	Remark
	MHz	dBuV/m	dB	dBuV/m	dBuV	dB/m	dB	dB	cm	deg	
1	2358.00	42.95	-31.05	74.00	40.81	32.33	5.49	35.67	100	0	Peak
2	2358.00	30.37	-23.63	54.00	28.23	32.33	5.49	35.67	100	1	Average
3 X	2480.00	80.01			78.02	32.30	5.38	35.70	100	1	Average
4 X	2480.00	94.71			92.71	32.30	5.38	35.70	100	0	Peak
5	2483.50	47.62	-26.38	74.00	45.63	32.30	5.38	35.70	100	0	Peak
6	2483.50	7.53	-46.47	54.00	5.54	32.30	5.38	35.70	100	1	Average
7	8790.00	55.34	-18.66	74.00	42.97	38.57	10.27	36.47	100	0	Peak
8	8790.00	44.16	-9.84	54.00	31.78	38.57	10.27	36.47	100	27	Average
9	9918.00	40.48	-33.52	74.00	75.79	-9.48	10.95	36.79	100	0	Peak



Test Mode :	Mode 3	Temperature :	26~28°C
Test Channel :	CH78_2480 MHz (1D Scanner with Battery 3600mAh)	Relative Humidity :	41~43%
Test Engineer :	Kay Wu	Polarization :	Vertical
Remark :	#3 and #4 are Fundamental Signals		

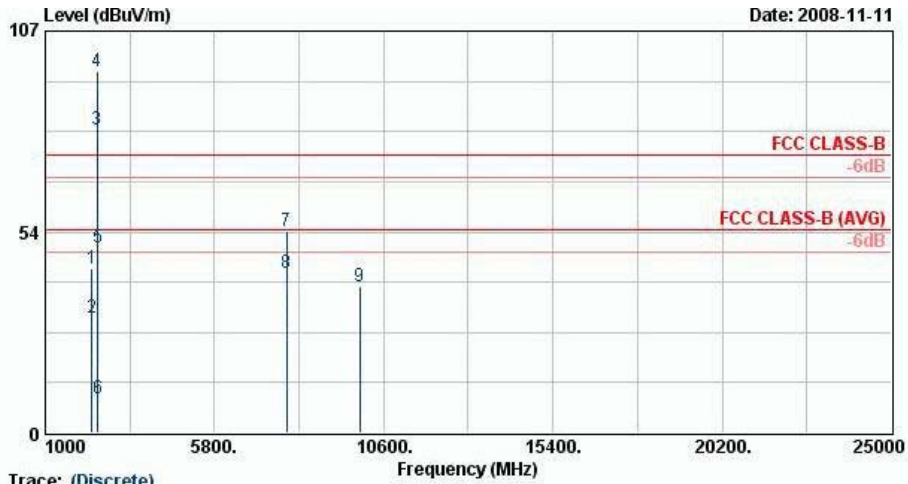

Trace: (Discrete)
 Site : 03CH07-HY
 Condition : 3m SHF-EHF HORN VERTICAL
 Model : FR 8O2928
 Mode : Mode 3
 Plane : H

	Freq	Level	Over	Limit	ReadAntenna	Cable	Preamp	Ant	Table	Remark
	MHz	dBuV/m	dB	dBuV/m	dBuV	dB/m	dB	dB	cm	deg
1	2316.00	43.78	-30.22	74.00	41.61	32.30	5.53	35.67	100	0 Peak
2	2316.00	30.55	-23.45	54.00	28.39	32.30	5.53	35.67	140	332 Average
3 @	2480.00	80.79			78.80	32.30	5.38	35.70	140	332 Average
4 X	2480.00	96.25			94.26	32.30	5.38	35.70	100	0 Peak
5	2483.50	49.16	-24.84	74.00	47.17	32.30	5.38	35.70	100	--- Peak
6	2483.50	9.07	-44.93	54.00	7.08	32.30	5.38	35.70	140	332 Average
7	7842.00	53.89	-20.11	74.00	43.45	36.93	9.77	36.27	100	0 Peak
8	7842.00	42.59	-11.41	54.00	32.15	36.93	9.77	36.27	100	146 Average
9	9918.00	38.97	-35.03	74.00	74.28	-9.48	10.95	36.79	100	0 Peak



Test Mode :	Mode 4	Temperature :	26~28°C
Test Channel :	CH00_2402 MHz (2D Scanner with Battery 3600mAh)	Relative Humidity :	41~43%
Test Engineer :	Kay Wu	Polarization :	Horizontal
Remark :	#3 and #4 are Fundamental Signals		

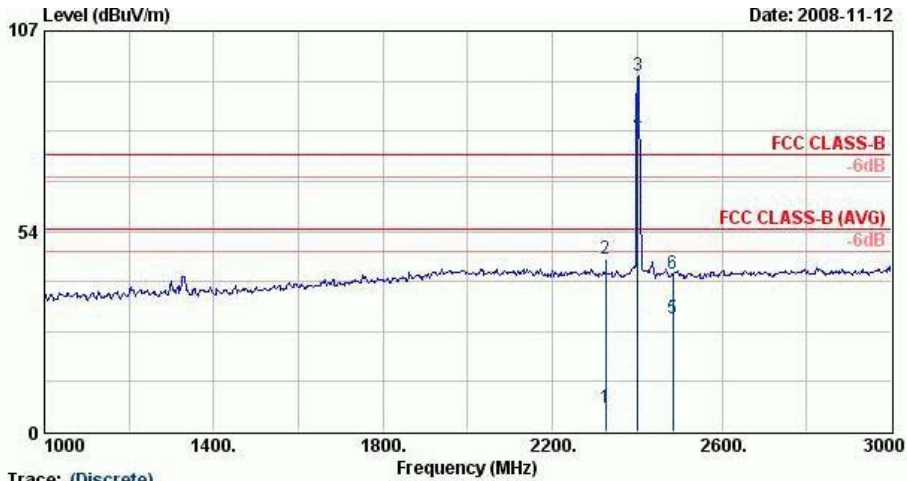

Trace: (Discrete)

Site : 03CH07-HY
 Condition : 3m HF-ANT(080305) HORIZONTAL
 Model : FR 8O2928
 Mode : Mode 4
 Plane : H

	Freq	Level	Over	Limit	Read	Antenna	Cable	Preamp	Ant	Table	Remark
	MHz	dBuV/m	dB	dBuV/m	dBuV	dB/m	dB	dB	cm	deg	
1	2324.82	6.22	-47.78	54.00	4.04	32.33	5.51	35.67	100	172	Average
2	2324.82	46.31	-27.69	74.00	44.13	32.33	5.51	35.67	100	0	Peak
3 @	2402.00	95.20			93.12	32.32	5.44	35.68	100	0	Peak
4 @	2402.00	80.50			78.40	32.32	5.46	35.68	100	172	Average
5 @	2483.50	30.22	-23.78	54.00	28.23	32.30	5.38	35.70	100	172	Average
6	2483.50	42.19	-31.81	74.00	40.20	32.30	5.38	35.70	100	0	Peak



Test Mode :	Mode 4	Temperature :	26~28°C
Test Channel :	CH00_2402 MHz (2D Scanner with Battery 3600mAh)	Relative Humidity :	41~43%
Test Engineer :	Kay Wu	Polarization :	Vertical
Remark :	#3 and #4 are Fundamental Signals		

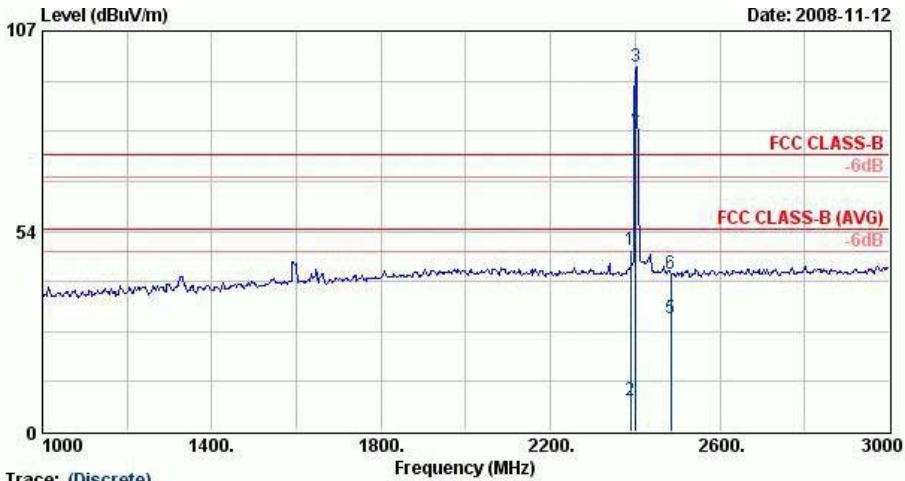

Trace: (Discrete)

Site : 03CH07-HY
 Condition : 3m HF-ANT(080305) VERTICAL
 Model : FR 802928
 Mode : Mode 4
 Plane : H

	Freq	Level	Over	Limit	Read	Antenna	Cable	Preamp	Ant	Table	Remark
	MHz	dBuV/m	dB	dBuV/m	dBuV	dB/m	dB	dB	cm	deg	
1 @	2389.61	48.51	-25.49	74.00	46.43	32.30	5.46	35.68	100	0	Peak
2	2389.61	8.42	-45.58	54.00	6.34	32.30	5.46	35.68	100	306	Average
3 @	2402.00	97.40			95.34	32.30	5.44	35.68	100	0	Peak
4 @	2402.00	81.77			79.69	32.30	5.46	35.68	100	306	Average
5 @	2483.50	30.35	-23.65	54.00	28.36	32.30	5.38	35.70	100	306	Average
6	2483.50	42.32	-31.68	74.00	40.33	32.30	5.38	35.70	100	0	Peak



Test Mode :	Mode 5	Temperature :	26~28°C
Test Channel :	CH78_2480 MHz (2D Scanner with Battery 3600mAh)	Relative Humidity :	41~43%
Test Engineer :	Kay Wu	Polarization :	Horizontal
Remark :	#3 and #4 are Fundamental Signals		

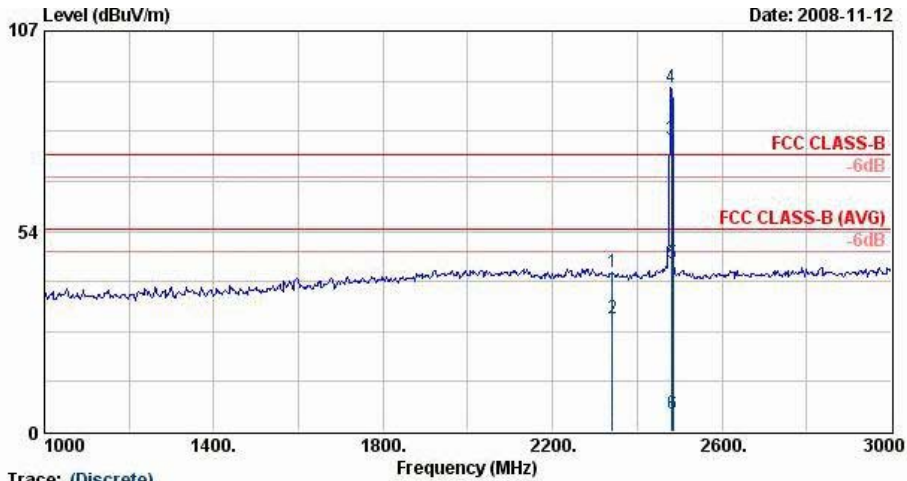

Site : 03CH07-HY
 Condition : 3m HF-ANT(080305) HORIZONTAL
 Model : FR 8O2928
 Mode : Mode 5
 Plane : H

	Freq	Level	Over	Limit	Read	Antenna	Cable	Preamp	Ant	Table	Remark
	MHz	dBuV/m	dB	dBuV/m	dBuV	dB/m	dB	dB	cm	deg	
1	2342.00	42.70	-31.30	74.00	40.54	32.33	5.50	35.67	100	0	Peak
2 @	2342.00	30.20	-23.80	54.00	28.04	32.33	5.50	35.67	100	359	Average
3 @	2480.00	78.10			76.11	32.30	5.38	35.70	100	359	Average
4 @	2480.00	92.03			90.03	32.30	5.38	35.70	100	0	Peak
5	2483.50	44.94	-29.06	74.00	42.95	32.30	5.38	35.70	100	0	Peak
6	2483.50	4.85	-49.15	54.00	2.86	32.30	5.38	35.70	100	359	Average



Test Mode :	Mode 5	Temperature :	26~28°C
Test Channel :	CH78_2480 MHz (2D Scanner with Battery 3600mAh)	Relative Humidity :	41~43%
Test Engineer :	Kay Wu	Polarization :	Vertical
Remark :	#3 and #4 are Fundamental Signals		

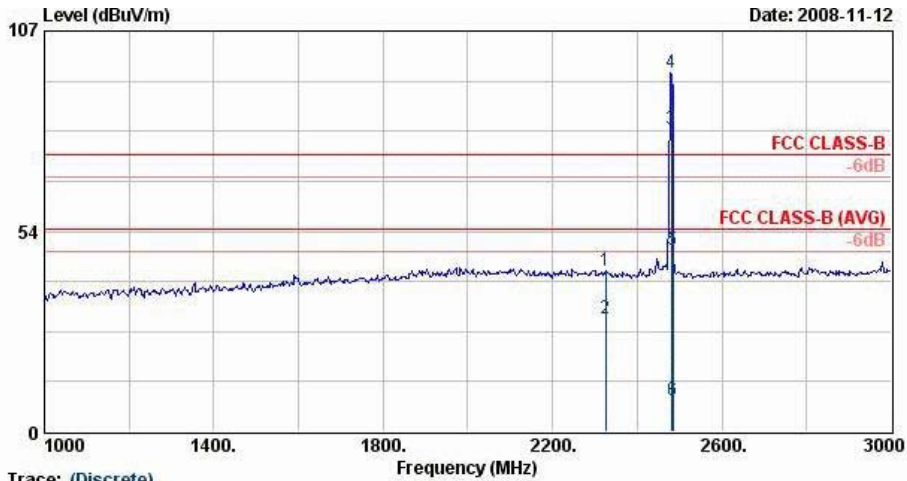

Trace: (Discrete)

Site : 03CH07-HY
 Condition : 3m HF-ANT(080305) VERTICAL
 Model : FR 802928
 Mode : Mode 5
 Plane : H

	Freq	Level	Over	Limit	Read	Antenna	Cable	Preamp	Ant	Table	Remark
	MHz	dBuV/m	dB	dBuV/m	dBuV	dB/m	dB	dB	cm	deg	
1	2326.00	43.08	-30.92	74.00	40.93	32.30	5.51	35.67	100		0 Peak
2 @	2326.00	30.24	-23.76	54.00	28.09	32.30	5.51	35.67	141		303 Average
3 @	2480.00	80.69			78.70	32.30	5.38	35.70	141		303 Average
4 @	2480.00	95.72			93.73	32.30	5.38	35.70	100		0 Peak
5 @	2483.50	48.63	-25.37	74.00	46.64	32.30	5.38	35.70	100		0 Peak
6	2483.50	8.54	-45.46	54.00	6.55	32.30	5.38	35.70	141		303 Average



3.9 Antenna Requirements

3.9.1 Standard Applicable

If directional gain of transmitting antennas is greater than 6dBi, the power shall be reduced by the same level in dB comparing to gain minus 6dBi.

The use of a permanently attached antenna or of an antenna that uses a unique coupling to the intentional radiator shall be considered sufficient to comply with the FCC rule.

3.9.2 Antenna Connected Construction

The antennas type used in this product is PIFA Antenna without connector and it is considered to meet antenna requirement.

3.9.3 Antenna Gain

The antenna peak gain of EUT is less than 6 dBi. Therefore, it is not necessary to reduce maximum peak output power limit.

4 List of Measuring Equipments

Instrument	Manufacturer	Model No.	Serial No.	Characteristics	Calibration Date	Due Date	Remark
Base Station	R&S	CMU200	105934	NA	Nov. 08, 2008	Nov. 07, 2009	Conducted (TH02-HY)
Spectrum Analyzer	R&S	FSP40	100055	9KHz~40GHz	Jun. 26, 2008	Jun. 25, 2009	Conducted (TH02-HY)
Power Meter	Agilent	E4416A	GB41292344	N/A	Feb. 21, 2008	Feb. 20, 2009	Conducted (TH02-HY)
Power Sensor	Agilent	E9327A	US40441548	N/A	Feb. 21, 2008	Feb. 20, 2009	Conducted (TH02-HY)
EMI Receiver	R&S	ESCS 30	100356	9kH~2.75GHz	Aug. 01, 2008	Jul. 31, 2009	Conduction (CO05-HY)
Two-LISN	R&S	ENV216	11-100081	9kH~30MHz	Nov. 26, 2008	Nov. 25, 2009	Conduction (CO05-HY)
Two-LISN	R&S	ENV216	11-100080	9kHz~30MHz	Nov. 26, 2008	Nov. 25, 2009	Conduction (CO05-HY)
DC- LISN	R&S	ESH3-26	1000485	0.1MHz~200MHz	Feb. 04, 2008	Feb. 03, 2009	Conduction (CO05-HY)
DC- LISN	R&S	ESH3-26	1000484	0.1MHz~200MHz	Feb. 04, 2008	Feb. 03, 2009	Conduction (CO05-HY)
AC Power Source	APC	APC-1000W	N/A	N/A	N/A	N/A	Conduction (CO05-HY)
GSM Base Station	R&S	CMU200	106656	N/A	May 06, 2008	May 05, 2009	Conduction (CO05-HY)
Bilog Antenna	SCHAFFNER	CBL6111C	2726	30MHz~1GHz	Nov. 20, 2008	Nov. 19, 2009	Radiation (03CH07-HY)
Spectrum Analyzer	R&S	FSP	101067	9kHz~30GHz	Dec. 05, 2007	Dec. 04, 2008	Radiation (03CH07-HY)
Double Ridge Horn Antenna	ESCO	3117	75962	1G~18GHz	Aug. 13, 2008	Aug. 12, 2009	Radiation (03CH07-HY)
Pre Amplifier	Agilent	8449B	3008A01917	1G~26.5GHz	Nov. 11, 2008	Nov. 10, 2009	Radiation (03CH07-HY)
Pre Amplifier	COM-POWER	PA-103A	161241	10~1000MHz. 32dB.GAIN	Mar. 31, 2008	Mar. 30, 2009	Radiation (03CH07-HY)
Double Ridge Horn Antenna	ESCO	3117	66584	1G~18GHz	Aug. 06, 2008	Aug. 05, 2009	Radiation (03CH07-HY)
GSM Base Station	R&S	CMU200	116456	NA	Jul. 05, 2008	Jul. 04, 2009	Radiation (03CH07-HY)
BT Base Station	Anritsu	MT8852B	6K00005722	N/A	Oct. 23, 2007	Oct. 22, 2009	Radiation (03CH07-HY)

5 Uncertainty of Evaluation

Uncertainty of Conducted Emission Measurement (150kHz ~ 30MHz)

Contribution	Uncertainty of x_i		$u(x_i)$
	dB	Probability Distribution	
Receiver reading	0.10	Normal(k=2)	0.05
Cable loss	0.10	Normal(k=2)	0.05
AMN insertion loss	2.50	Rectangular	0.63
Receiver Spec	1.50	Rectangular	0.43
Site imperfection	1.39	Rectangular	0.80
Mismatch	+0.34/-0.35	U-shape	0.24
Combined standard uncertainty Uc(y)	1.13		
Measuring uncertainty for a level of confidence of 95% U=2Uc(y)	2.26		

Uncertainty of Radiated Emission Measurement (30MHz ~ 1000MHz)

Contribution	Uncertainty of x_i		$u(x_i)$
	dB	Probability Distribution	
Receiver reading	0.41	Normal(k=2)	0.21
Antenna factor calibration	0.83	Normal(k=2)	0.42
Cable loss calibration	0.25	Normal(k=2)	0.13
Pre Amplifier Gain calibration	0.27	Normal(k=2)	0.14
RCV/SPA specification	2.50	Rectangular	0.72
Antenna Factor Interpolation for Frequency	1.00	Rectangular	0.29
Site imperfection	1.43	Rectangular	0.83
Mismatch	+0.39/-0.41	U-shaped	0.28
Combined standard uncertainty Uc(y)	1.27		
Measuring uncertainty for a level of confidence of 95% U=2Uc(y)	2.54		

Uncertainty of Radiated Emission Measurement (1GHz ~ 40GHz)

Contribution	Uncertainty of x_i		$u(x_i)$	C_i	$C_i * u(x_i)$
	dB	Probability Distribution			
Receiver reading	±0.10	Normal(k=1)	0.10	1	0.10
Antenna factor calibration	±1.70	Normal(k=2)	0.85	1	0.85
Cable loss calibration	±0.50	Normal(k=2)	0.25	1	0.25
Receiver Correction	±2.00	Rectangular	1.15	1	1.15
Antenna Factor Directional	±1.50	Rectangular	0.87	1	0.87
Site imperfection	±2.80	Triangular	1.14	1	1.14
Mismatch Receiver VSWR $\Gamma_1 = 0.197$ Antenna VSWR $\Gamma_2 = 0.194$ Uncertainty = $20 \log(1 - \Gamma_1 * \Gamma_2)$	+0.34/-0.35	U-shaped	0.244	1	0.244
Combined standard uncertainty $U_c(y)$	2.36				
Measuring uncertainty for a level of confidence of 95% $U = 2U_c(y)$	4.72				

6 Certification of TAF Accreditation



Certificate No. : L1190-070110

財團法人全國認證基金會
Taiwan Accreditation Foundation

Certificate of Accreditation

This is to certify that

Sporton International Inc.
EMC & Wireless Communications Laboratory
No.52, Hwa Ya 1st Rd., Hwa Ya Technology Park, Kwei-Shan Hsiang, Tao Yuan Hsien,
Taiwan, R.O.C.

is accredited in respect of laboratory

Accreditation Criteria	: ISO/IEC 17025:2005
Accreditation Number	: 1190
Originally Accredited	: December 15, 2003
Effective Period	: January 10, 2007 to January 09, 2010
Accredited Scope	: Testing Field, see described in the Appendix Accreditation Program for Designated Testing Laboratory
Specific Accreditation Program	: for Commodities Inspection Accreditation Program for Telecommunication Equipment Testing Laboratory

Jay-San Chen
President, Taiwan Accreditation Foundation
Date : January 10, 2007

PI, total 9 pages

The Appendix forms an integral part of this Certificate, which shall be invalid when used without the Appendix.



Appendix A. Photographs of EUT

Please refer to Sporton report number EP8O2928 as below.