



A Test Lab Techno Corp.

Changan Lab : No. 140 -1, Changan Street, Bade City, Taoyuan County, Taiwan R.O.C.
Tel : 886-3-271-0188 / Fax : 886-3-271-0190

HAC EVALUATION REPORT



Test Report No.	: 0706FH12
Applicant	: Symbol Technologies, Inc.
Trade Name	: Symbol
Model Name	: MC3504
FCC ID	: H9PMC3504
EUT Type	: EDA(Enterprise Digital Assistant)
Dates of Test	: May. 30 ~ 31, 2007
Test Environment	: Ambient Temperature : 22 ± 3 °C Relative Humidity : 40 - 70 %
FCC Rule Part(s)	: FCC 47 CFR § 20.19.
HAC Standard	: ANSI PC63.19-2006
PC63.19 HAC Rated Category	: M3 (RF EMISSIONS)
Test Lab	: Changan Lab

1. The test operations have to be performed with cautious behavior, the test results are as attached.
2. The test results are under chamber environment of A Test Lab Techno Corp. A Test Lab Techno Corp. does not assume responsibility for any conclusions and generalizations drawn from the test results with regard to other specimens or samples.
3. The measurement report has to be written approval of A Test Lab Techno Corp. It may only be reproduced or published in full

Country Huang 20070605
Testing Center Manager

Sam Chuang 20070605
Testing Engineer



Contents

1. Description of Equipment Under Test (EUT).....	3
2. Introduction	4
3. Test Equipment List.....	5
4. Validation	6
5. Probe Modulation Factor.....	8
6. Test Results	10
Appendix A - EUT with Accessories Picture.....	15
Appendix B - Details of WD signal	17
Appendix C - Validation.....	19
Appendix D - HAC distribution plots for E-Field and H-Field.....	24
Appendix E - Calibration.....	37



1. Description of Equipment Under Test (EUT)

Applicant :

Symbol Technologies, Inc.

One Symbol Plaza Holtsville, NY United States 11742-1300.

Manufacturer : WISTRON CORPORATION
Manufacturer Address : 21F, 88 Sec. 1 Hsin Tai Wu Rd., Hsichih, Taipei 221,
Taiwan, R.O.C.
EUT Type : EDA(Enterprise Digital Assistant)
Trade Name : Symbol
Model Name : MC3504
FCC ID : H9PMC3504
Tx Frequency : 824.2 - 848.8 MHz (GSM 850)
1850.2 - 1909.8 MHz(GSM 1900)
Max. Output Power : 32.10 dBm GSM 850
29.50 dBm GSM 1900
HW Version : MC3574 Rev 1-MV
SW Version : X21
Antenna Type : Internal Type
(Antenna Gain GSM 850 = -1.46 dBi / GSM 1900 =2.10 dBi)
Test Device : Identical Prototype
Device Category : Portable

This wireless portable device has performed Hearing Aid Compatibility (HAC) measurements for the portable cellular phone. The measurements were performed to ensure compliance to the ANSI PC63.19-2001 rd 3.12 standards, which is the same as the ANSI C63.19-2006 per the FCC public notice DA 06-1215.



2. Introduction

The A Test Lab Techno Corp. has performed measurements of the maximum potential exposure to the user of **Symbol Technologies, Inc. Trade Name: Symbol Model(s) : MC3504**. The test procedures, as described in ANSI PC63.19-2006 standard were employed. A description of the product and operating configuration, detailed summary of the test results, methodology and procedures used in the equipment are included within this test report.



3. Test Equipment List

Manufacturer	Name of Equipment	Type/Model	Serial Number	Calibration	
				Last Cal.	Due Date
SPEAG	Dosimetric E-Filed Probe	ER3DV6	2302	Mar. 21,2007	Mar. 21,2008
SPEAG	Dosimetric H-Filed Probe	H3DV6	6187	Mar. 21,2007	Mar. 21,2008
SPEAG	835 MHz System Validation Kit	CD835V3	1052	Jan. 16, 2007	Jan. 16, 2008
SPEAG	1880 MHz System Validation Kit	CD1880V3	1044	Jan. 16, 2007	Jan. 16, 2008
SPEAG	Data Acquisition Electronics	DAE4	541	Oct. 16, 2006	Oct. 16, 2006
SPEAG	Device Holder	N/A	N/A	NCR	NCR
SPEAG	HAC Test Arch	SD-HAC-P01-BA	1038	NCR	NCR
SPEAG	Robot	Staubli RX90L	F00/589B1/A/01	NCR	NCR
SPEAG	Software	DASY4 V4.7 Build 53	N/A	NCR	NCR
SPEAG	Software	SEMCAD V1.8 Build 172	N/A	NCR	NCR
SPEAG	Measurement Server	SE UMS 001 BA	1021	NCR	NCR
Agilent	Wireless Communication Test Set	8960(E5515C)	GB47020167	Feb. 14, 2007	Feb. 14, 2008
Agilent	S-Parameter Network Analyzer	E5071B	MY42404655	Feb. 05, 2007	Feb. 05, 2008
Agilent	Spectrum Analyzer(PSA)	E4445A	MY45300744	Nov. 11, 2006	Nov. 11, 2007
Agilent	Power Meter	E4418B	GB40206143	May. 23, 2007	May. 23, 2008
Agilent	Signal Generator	8648C	3847A05201	July 06, 2006	July 06, 2007
Agilent	Power Sensor	8481H	3318A20779	May. 28, 2007	May. 28, 2008
Agilent	Dual Directional Coupler	778D	50334	NCR	NCR
Mini-Circuits	Power Amplifier	ZVE-8G	D042005 671800514	NCR	NCR
Mini-Circuits	Power Amplifier	ZHL-42W-SMA	D111103#5	NCR	NCR

Table 1. Test Equipment List



4. Validation

Validations of the DASY4 v4.7 test system were performed using the measurement equipment listed in Section 3.1. All validations occur in free space using the DASY4 test arch. Note that the 10mm probe to dipole separation is measured from the top edge of the dipole to the calibration reference point of the probe. SPEAG uses the center point of the probe sensor(s) as the reference point when establishing targets for their dipoles. Therefore, because SPEAG's dipoles and targets are used, it is appropriate to measure the 10mm separation distance to the center of the sensors as they do. This reference point was used for validation only. Validations were performed at 835 MHz and/or 1880 MHz. These frequencies are within each operating band and are within 2MHz of the mid-band frequency of the test device. The obtained results from the validations are displayed in the table below. The field contour plots are included in Appendix B.

Validations were performed to verify that measured E-field and H-field values are within +/- 25% from the target reference values provided by the manufacturer (Ref: Appendix D). Per Section 4.2.2.1 of the C63.19 standard, "Values within +/-25% are acceptable, of which 12% is deviation and 13% is measurement uncertainty." Therefore, the E-Field and H-Field dipole verification results, shown in Table 4, are in accordance with the acceptable parameters defined by the standard.

Dipole	Freq. (MHz)	Protocol	Input Power (mW)	E-Field Results (V/m)	Target for Dipole (V/m)	% Deviation	Date
SN:1052	835	CW	100	166.6	173.1	3.90	May. 30, 2007
SN:1044	1880	CW	100	135.3	147.9	9.31	May. 30, 2007

Table 2. Dipole E-Field Measurement Summary

Dipole	Freq. (MHz)	Protocol	Input Power (mW)	H-Field Results (A/m)	Target for Dipole (A/m)	% Deviation	Date
SN:1052	835	CW	100	0.450	0.482	7.11	May. 30, 2007
SN:1044	1880	CW	100	0.457	0.469	2.63	May. 30, 2007

Table 3. Dipole H-Field Measurement Summary

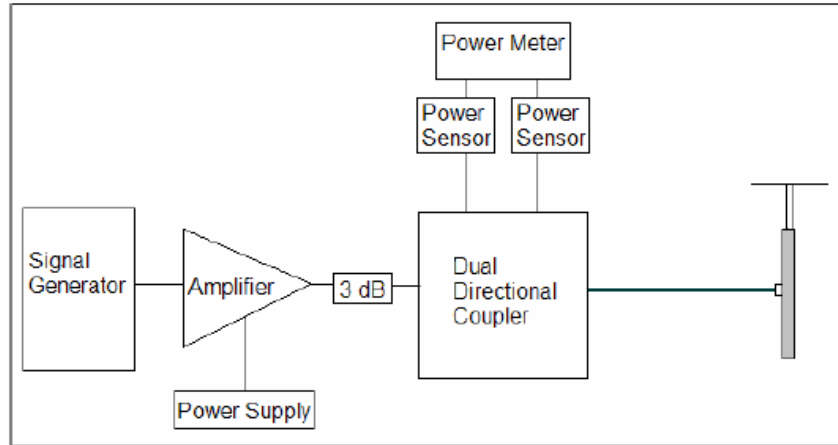

Figure 1. Setup for Validation

5. Probe Modulation Factor

After every probe calibration, the response of the probe to each applicable modulated signal (CDMA, GSM, etc) must be assessed at both 835 MHz, 1880 MHz. The response of the probe system to a CW field at the frequency(s) of interest is compared to its response to a modulated signal with equal peak amplitude. For each PMF assessment, a Signal Generator was used to replace the original CW signal with the desired modulated signal. The PMF results are shown in Tables 4. RF Field Probe Modulation Response was measured with the field probe and associated measurement equipment. The PMF was measured per ANSI PC63.19-2006 using a signal generator as follows:

1. Illuminate a dipole with a CW signal at the intended measured frequency.
2. Fix the probe at a set location relative to the dipole; typically located at the field reference point.
3. Record the reading of the probe measurement system of the CW signal.
4. Substitute a modulated signal of the same amplitude, using the same modulation as that used by the intended WD for the CW signal.
5. Record the reading of the probe measurement system of the modulated signal.
6. The ratio of the CW to modulated signal reading is the probe modulation factor.

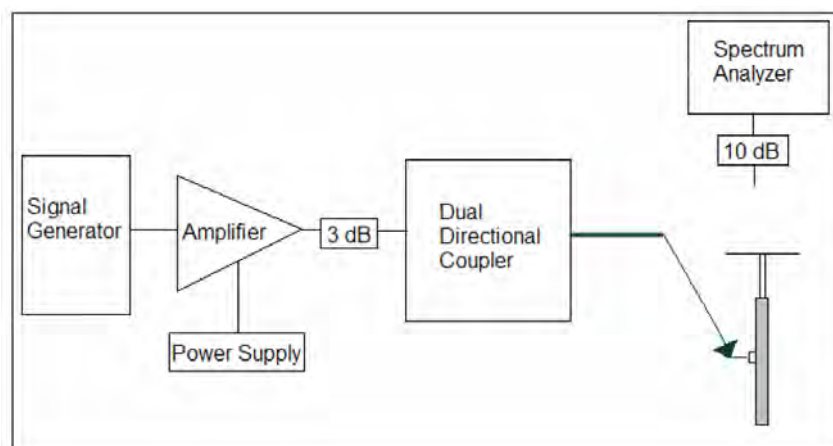

Figure 2. Setup to Dipole

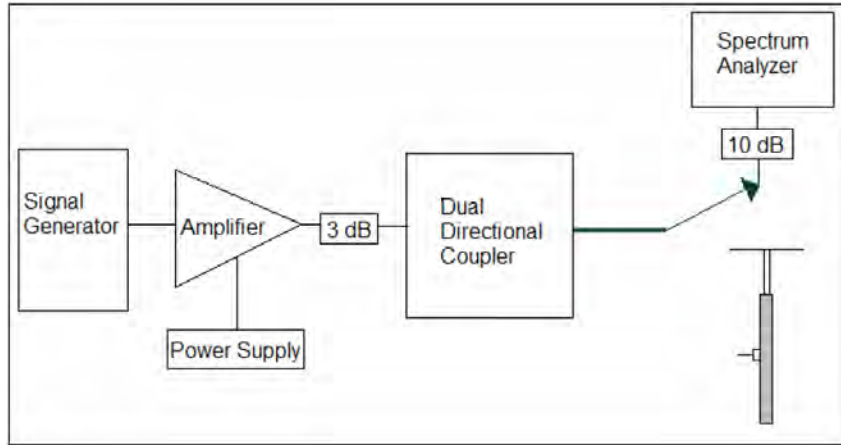

Figure 3. Setup for Desired Peak Power using Spectrum Analyzer

F (MHz)	Protocol	Peak Power (mW)	E-Field Probe SN:2256		H-Field Probe SN:6076	
			E-Field (V/m)	E-Field Modulation Factor	H-Field (A/m)	H-Field Modulation Factor
836.5	CW	100	151.20		0.53	
	80% AM	100	94.14	1.61	0.32	1.65
	GSM	100	57.62	2.62	0.20	2.73
1880	CW	100	162.00		0.65	
	80% AM	100	104.69	1.55	0.41	1.57
	GSM	100	62.79	2.58	0.27	2.40

Table 4. PMF Measurement Summary

Note: PMF measurements were verified at WD's power as an input to the dipole.



6. Test Results

The phone was tested in all normal configurations for the ear use. When applicable, each configuration is tested with the antenna in its fully extended and fully retracted positions. These test configurations are tested at the high, middle and low frequency channels of each applicable operating mode; for example, GSM, CDMA and TDMA.

The signal was setup by creating and maintaining an over the air connection between the DUT and an Agilent 8960 Wireless Communications Test Set. The CDMA radio is available on CDMA 2000(1X) and IS-95. The test equipment was configured to use "all up bits" for RC1 / SO2 on J-STD-008 for CDMA 1900 and TSB-84 for CDMA 800 MHz. The Wideband and Zero Span spectrum analyzer plots are shown in Appendix A.

The DASY4 v4.6 measurement system specified in section 3.1 was utilized within the intended operations as set by the SPEAG™ setup. The default settings for the grid spacing of the scan were set to 5mm as shown in the Field plots included in Appendix B and C. The 5cm x 5cm area measurement grid is centered on the acoustic output of the device. The Test Arch provided by SPEAG is used to position the DUT. The WD reference plane is parallel to the device and contains the highest point on its contour in the area of the phone that normally rests against the user's ear. The measurement plane contains the nearest point on the probe sensor(s) relative to the WD. The pictures of the setup are included in 7.3.

The device is positioned such that the WD reference plane is located 10mm from, and parallel to, the measurement plane. This is in accordance with section 4.3 of the standard, which states that "The WD reference plane is a plane parallel with the front "face" of the WD and containing the highest point on its contour in the area of the phone that normally rests against the user's ear."



The following figure shows the position of the measurement grid with respect to the device under test.

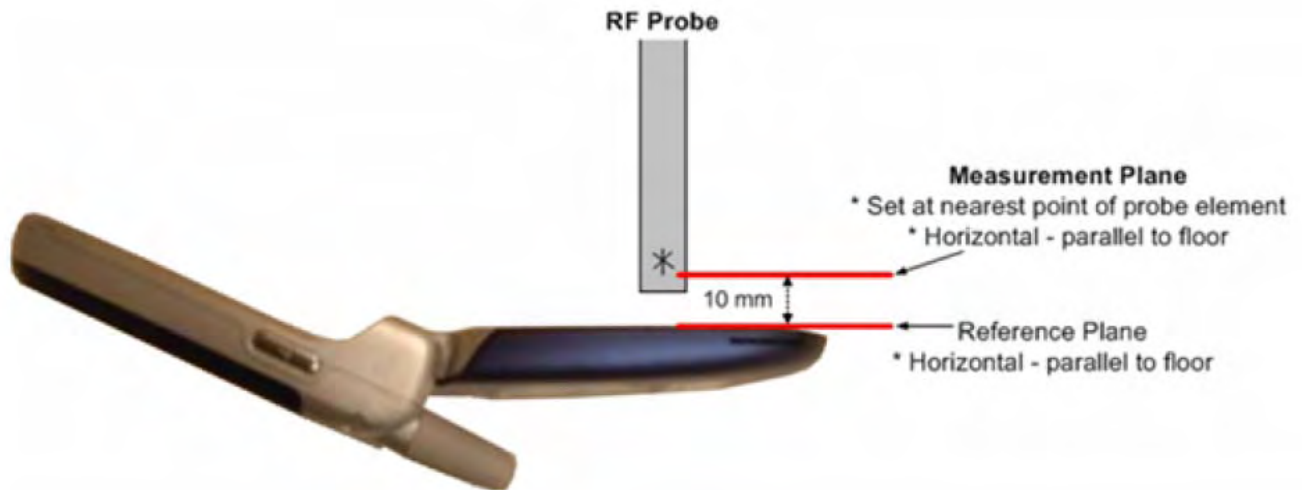

Figure 4. Clarification of Figure A-2 from the Standard

The HAC Rating results for E-Field and H-field are shown in 7.1 and 7.2. Also shown are the measured conducted output powers, the measured drifts, excluded areas, and the peak fields. PMF measurements are taken from Section 5. The worst-case test conditions are indicated with bold numbers in the tables and are detailed in Appendix C: HAC distribution plots for E-Field and H-Field.

Drift was measured using the typical DASY4 v4.7 measurement routines. The field is measured at the reference location (center of the ear piece) at the beginning of the test. Then after completion of the E or H field measurement, the probe returns to the same reference location and takes another measurement. The drift is the delta between these two values and is included in the test report scans.

The cellular phone model covered by this report has the following battery options:

Battery -

1. BTRY-MC35EABOE 3.7V 1370mAh
2. BTRY-MC35EABO2 3.7V 2740mAh



6.1 HAC E-Field measurement results:

Band	Rating	E-Field
GSM 850	M3	149.6 to 266.1 V/m
	M4	< 149.6 V/m
GSM 1900	M3	47.3 to 84.1 V/m
	M4	<47.3 V/m

Table 5. Emissions Limits

Band	Channel	Conducted Power (dBm)	Measured PMF	Drift (dB)	Excluded Cells	Peak Field (V/m)	Rating
GSM 850	128	32.0	2.62	0.030	6,8,9	138.9	M4
	190	31.9		0.045	6,8,9	173.7	M3
	251	32.1		-0.024	6,8,9	207.2	M3
GSM 1900	512	29.5	2.58	-0.015	7,8,9	59.8	M3
	661	29.1		-0.033	7,8,9	61.7	M3
	810	28.6		-0.056	7,8,9	70.2	M3

Note: HAC E-Field measurement results for the portable cellular telephone at highest possible output power.



6.2 HAC H-Field measurement results:

Band	Rating	H-Field
GSM 850	M3	0.45 to 0.80 A/m
	M4	< 0.45 A/m
GSM 1900	M3	0.14 to 0.25 A/m
	M4	<0.14 A/m

Table 6. Emissions Limits

Band	Channel	Conducted Power (dBm)	Measured PMF	Drift (dB)	Excluded Cells	Peak Field (A/m)	Rating
GSM 850	128	32.0	2.62	0.022	2,3,6	0.372	M4
	190	31.9		-0.012	1,2,3	0.457	M3
	251	32.1		-0.197	2,3,6	0.539	M3
GSM 1900	512	29.5	2.58	-0.102	2,3,6	0.212	M3
	661	29.1		-0.017	2,3,6	0.217	M3
	810	28.6		0.007	2,3,6	0.239	M3

Note: HAC E-Field measurement results for the portable cellular telephone at highest possible output power.

6.3 Pictures of Test Setup:



Figure 5. View from the front



Figure 6. View from the side

Appendix A - EUT with Accessories Picture







Appendix B - Details of WD signal

836 MHz

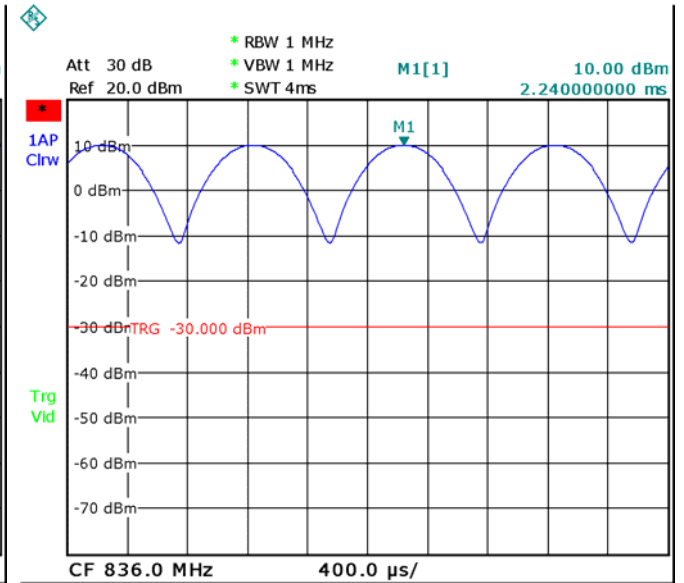
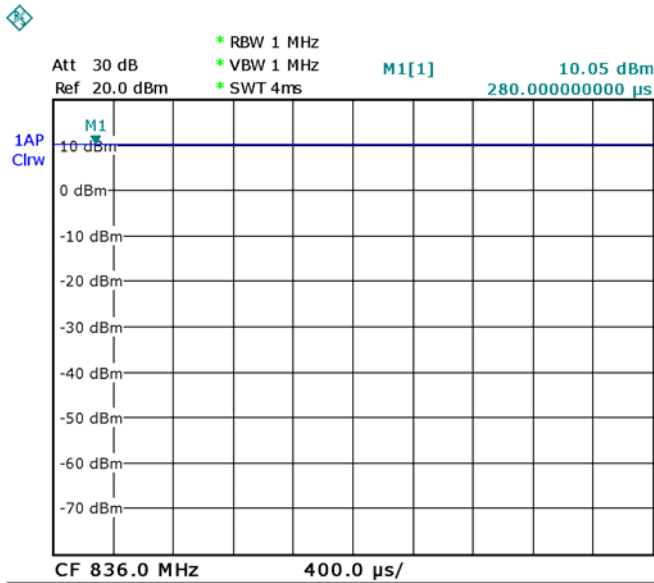

CW Signal

80% AM Signal

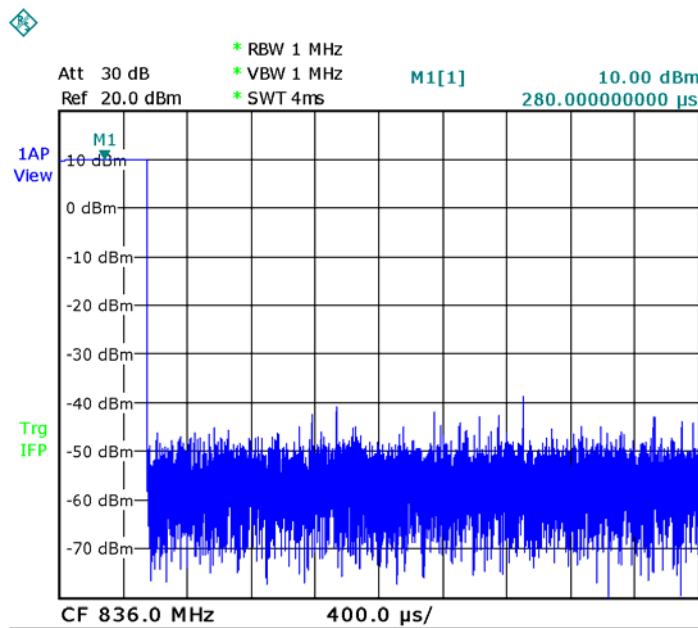

GSM Signal



1880 MHz

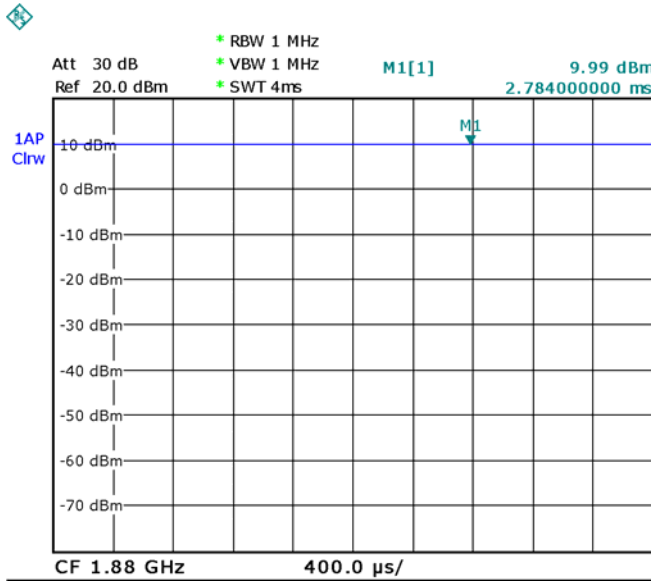

CW Signal

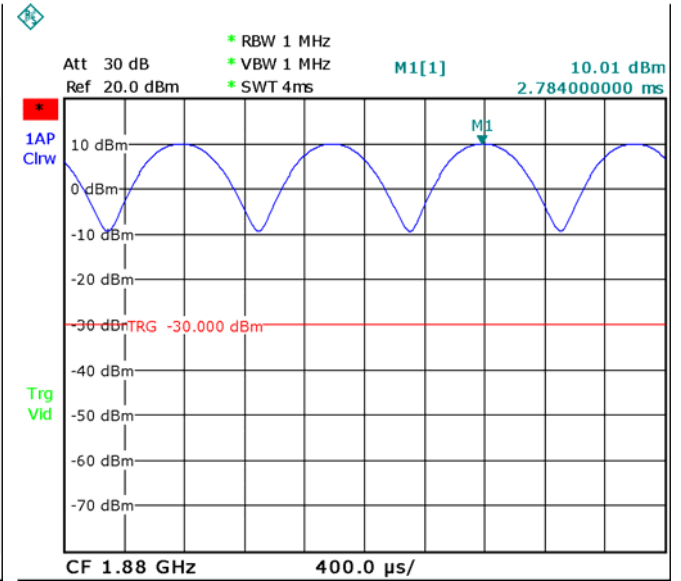

80% AM Signal

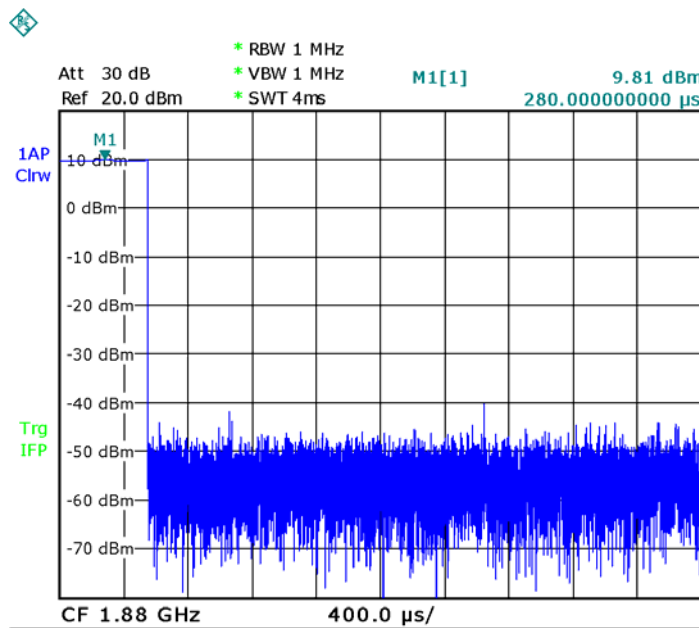

GSM Signal



Appendix C - Validation

See following Attached Pages for Validation.



Test Laboratory: A Test Lab Techno Corp. Date/Time: 5/30/2007 10:01:26 AM

HAC_System Performance Check at 835MHz_20070530_E

DUT: Dipole 835 MHz; Type: CD835V3; Serial: CD835V3 - SN:1052

Communication System: CW; Frequency: 835 MHz;Duty Cycle: 1:1

Medium parameters used: $\sigma = 0$ mho/m, $\epsilon_r = 1$; $\rho = 1000$ kg/m³

Phantom section: E Dipole Section

Measurement Standard: DAS4 (High Precision Assessment)

DASY4 Configuration:

- Probe: ER3DV6 - SN2302; ConvF(1, 1, 1); Calibrated: 3/21/2007
- Sensor-Surface: (Fix Surface)
- Electronics: DAE4 Sn541; Calibrated: 10/16/2006
- Phantom: HAC Test Arch; Type: SD HAC P01 BA; Serial:
- Measurement SW: DAS4, V4.7 Build 53; Postprocessing SW: SEMCAD, V1.8 Build 172

E Scan - ER3DV6 probe tip 10mm above Device Reference/Hearing Aid Compatibility Test (41x361x1):

Measurement grid: dx=5mm, dy=5mm

Maximum value of peak Total field = 173.1 V/m

Probe Modulation Factor = 1.00

Reference Value = 144.0 V/m; Power Drift = -0.023 dB

Hearing Aid Near-Field Category: M4 (AWF 0 dB)

Peak E-field in V/m

Grid 1	Grid 2	Grid 3
162.0	166.9	162.2
Grid 4	Grid 5	Grid 6
91.6	93.7	91.0
Grid 7	Grid 8	Grid 9
171.6	173.1	164.6

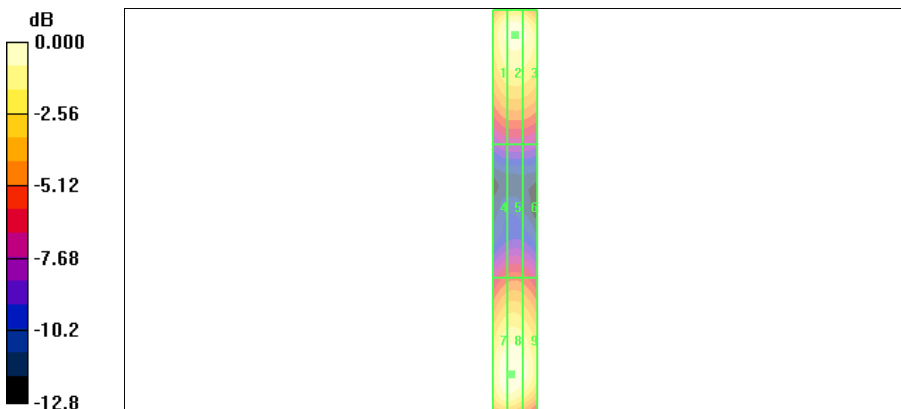

0 dB= 173.1V/m



Test Laboratory: A Test Lab Techno Corp. Date/Time: 5/30/2007 1:20:57 PM

HAC_System Performance Check at 835MHz_20070531_H

DUT: Dipole 835 MHz; Type: CD835V3; Serial: CD835V3 - SN:1052

Communication System: CW; Frequency: 835 MHz; Duty Cycle: 1:1

Medium parameters used: $\sigma = 0$ mho/m, $\epsilon_r = 1$; $\rho = 1$ kg/m³

Phantom section: H Dipole Section

Measurement Standard: DAS4 (High Precision Assessment)

DASY4 Configuration:

- Probe: H3DV6 - SN6187; ; Calibrated: 3/21/2007
- Sensor-Surface: (Fix Surface)
- Electronics: DAE4 Sn541; Calibrated: 10/16/2006
- Phantom: HAC Test Arch; Type: SD HAC P01 BA; Serial:
- Measurement SW: DAS4, V4.7 Build 53; Postprocessing SW: SEMCAD, V1.8 Build 172

H Scan - H3DVV6 probe tip 10mm above Device Reference/Hearing Aid Compatibility Test (41x361x1):

Measurement grid: dx=5mm, dy=5mm

Maximum value of peak Total field = 0.482 A/m

Probe Modulation Factor = 1.00

Reference Value = 0.522 A/m; Power Drift = 0.007 dB

Hearing Aid Near-Field Category: M4 (AWF 0 dB)

Peak H-field in A/m

Grid 1	Grid 2	Grid 3
0.405	0.432	0.419
Grid 4	Grid 5	Grid 6
0.454	0.482	0.466
Grid 7	Grid 8	Grid 9
0.405	0.428	0.411

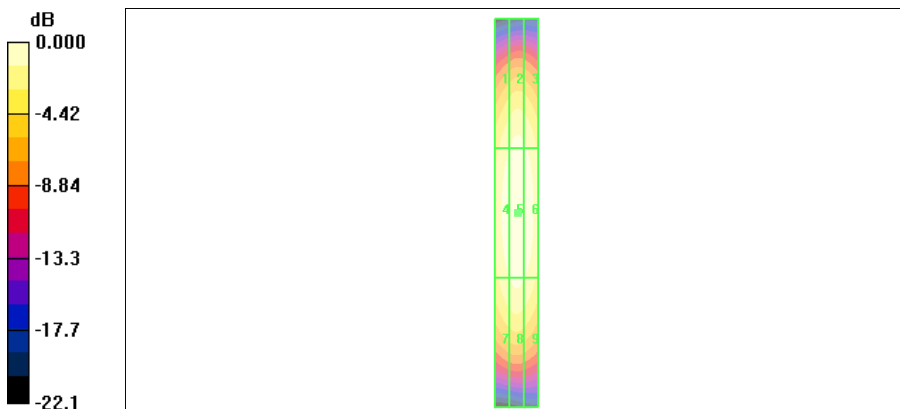

0 dB = 0.482A/m



Test Laboratory: A Test Lab Techno Corp. Date/Time: 5/30/2007 11:47:40 AM

HAC_System Performance Check at 1880MHz_20070530_E

DUT: Dipole 1880 MHz; Type: CD1880V3; Serial: CD1880V3 - SN:1044

Communication System: CW; Frequency: 1880 MHz; Duty Cycle: 1:1

Medium parameters used: $\sigma = 0$ mho/m, $\epsilon_r = 1$; $\rho = 1000$ kg/m³

Phantom section: E Dipole Section

Measurement Standard: DAS4 (High Precision Assessment)

DASY4 Configuration:

- Probe: ER3DV6 - SN2302; ConvF(1, 1, 1); Calibrated: 3/21/2007
- Sensor-Surface: (Fix Surface)
- Electronics: DAE4 Sn541; Calibrated: 10/16/2006
- Phantom: HAC Test Arch; Type: SD HAC P01 BA; Serial:
- Measurement SW: DAS4, V4.7 Build 53; Postprocessing SW: SEMCAD, V1.8 Build 172

E Scan - ER3DV6 probe tip 10mm above Device Reference/Hearing Aid Compatibility Test (41x181x1):

Measurement grid: dx=5mm, dy=5mm

Maximum value of peak Total field = 147.9 V/m

Probe Modulation Factor = 1.00

Reference Value = 147.3 V/m; Power Drift = 0.008 dB

Hearing Aid Near-Field Category: M2 (AWF 0 dB)

Peak E-field in V/m

Grid 1	Grid 2	Grid 3
129.7	147.9	147.7
Grid 4	Grid 5	Grid 6
81.1	89.1	89.3
Grid 7	Grid 8	Grid 9
119.9	132.8	132.8

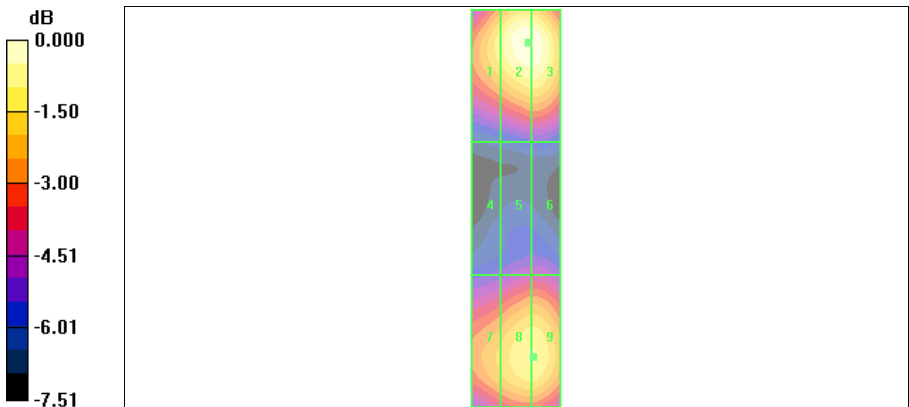

0 dB = 147.9V/m



Test Laboratory: A Test Lab Techno Corp. Date/Time: 5/30/2007 10:43:12 AM

HAC_System Performance Check at 1880MHz_20070530_H

DUT: Dipole 1880 MHz; Type: CD1880V3; Serial: CD1880V3 - SN:1044

Communication System: CW; Frequency: 1880 MHz; Duty Cycle: 1:1

Medium parameters used: $\sigma = 0$ mho/m, $\epsilon_r = 1$; $\rho = 1$ kg/m³

Phantom section: H Dipole Section

Measurement Standard: DAS4 (High Precision Assessment)

DASY4 Configuration:

- Probe: H3DV6 - SN6187; ; Calibrated: 3/21/2007
- Sensor-Surface: (Fix Surface)
- Electronics: DAE4 Sn541; Calibrated: 10/16/2006
- Phantom: HAC Test Arch; Type: SD HAC P01 BA; Serial:
- Measurement SW: DAS4, V4.7 Build 53; Postprocessing SW: SEMCAD, V1.8 Build 172

H Scan - H3DVV6 probe tip 10mm above Device Reference/Hearing Aid Compatibility Test (41x181x1):

Measurement grid: dx=5mm, dy=5mm

Maximum value of peak Total field = 0.469 A/m

Probe Modulation Factor = 1.00

Reference Value = 0.550 A/m; Power Drift = -0.062 dB

Hearing Aid Near-Field Category: M2 (AWF 0 dB)

Peak H-field in A/m

Grid 1	Grid 2	Grid 3
0.413	0.441	0.426
Grid 4	Grid 5	Grid 6
0.444	0.469	0.456
Grid 7	Grid 8	Grid 9
0.393	0.415	0.404

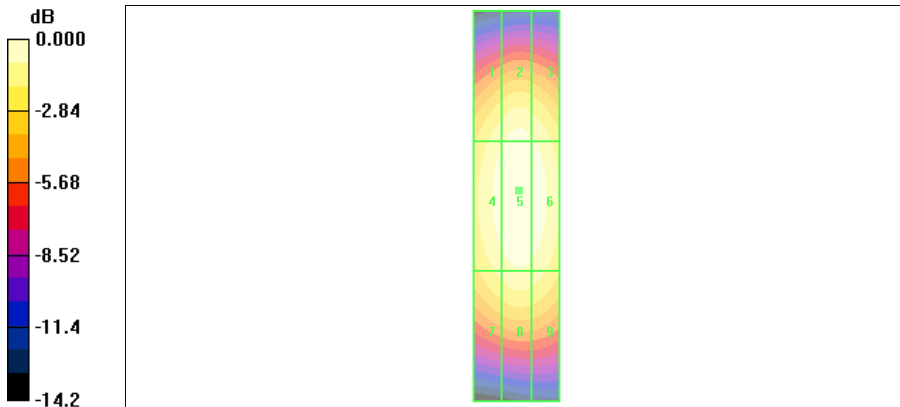

0 dB = 0.469A/m



Appendix D - HAC distribution plots for E-Field and H-Field

See following Attached Pages for HAC distribution plots for E-Field and H-Field.



Test Laboratory: A Test Lab Techno Corp. Date/Time: 5/30/2007 12:25:21 PM

HAC_GSM 850 CH128_E

DUT: MC3504; Type: PDA; FCC ID:H9PMC3504

Communication System: GSM850; Frequency: 824.2 MHz;Duty Cycle: 1:8.3

Medium parameters used: $\sigma = 0$ mho/m, $\epsilon_r = 1$; $\rho = 1000$ kg/m³

Phantom section: E Device Section

Measurement Standard: DAS4 (High Precision Assessment)

DASY4 Configuration:

- Probe: ER3DV6 - SN2302; ConvF(1, 1, 1); Calibrated: 3/21/2007
- Sensor-Surface: (Fix Surface)
- Electronics: DAE4 Sn541; Calibrated: 10/16/2006
- Phantom: HAC Test Arch; Type: SD HAC P01 BA; Serial:
- Measurement SW: DAS4, V4.7 Build 53; Postprocessing SW: SEMCAD, V1.8 Build 172

E Scan - ER3DV6 probe center 10mm above Device Reference/Hearing Aid Compatibility Test (101x101x1):

Measurement grid: dx=5mm, dy=5mm

Maximum value of peak Total field = 138.9 V/m

Probe Modulation Factor = 2.62

Reference Value = 56.3 V/m; Power Drift = 0.030 dB

Hearing Aid Near-Field Category: M4 (AWF -5 dB)

Peak E-field in V/m

Grid 1	Grid 2	Grid 3
109.2	131.6	125.4
Grid 4	Grid 5	Grid 6
117.3	138.9	130.1
Grid 7	Grid 8	Grid 9
119.2	137.0	127.3

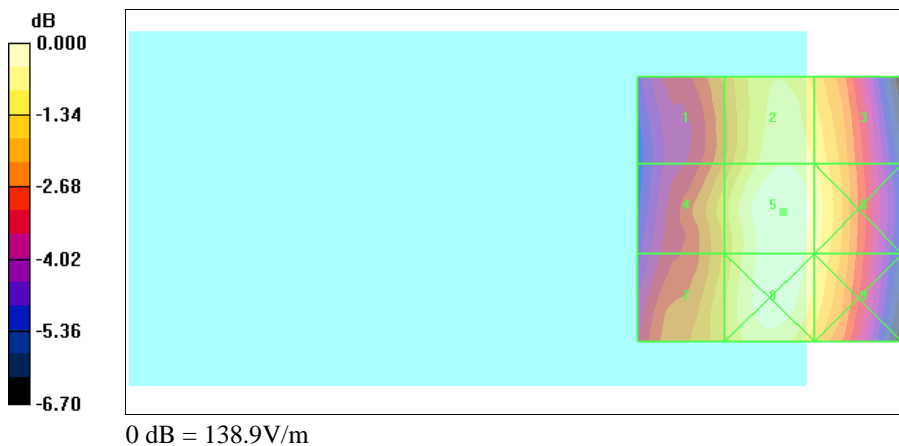



Test Laboratory: A Test Lab Techno Corp. Date/Time: 5/30/2007 12:32:08 PM

HAC_GSM 850 CH190_E

DUT: MC3504; Type: PDA; FCC ID:H9PMC3504

Communication System: GSM850; Frequency: 836.6 MHz;Duty Cycle: 1:8.3

Medium parameters used: $\sigma = 0$ mho/m, $\epsilon_r = 1$; $\rho = 1000$ kg/m³

Phantom section: E Device Section

Measurement Standard: DAS4 (High Precision Assessment)

DASY4 Configuration:

- Probe: ER3DV6 - SN2302; ConvF(1, 1, 1); Calibrated: 3/21/2007
- Sensor-Surface: (Fix Surface)
- Electronics: DAE4 Sn541; Calibrated: 10/16/2006
- Phantom: HAC Test Arch; Type: SD HAC P01 BA; Serial:
- Measurement SW: DAS4, V4.7 Build 53; Postprocessing SW: SEMCAD, V1.8 Build 172

E Scan - ER3DV6 probe center 10mm above Device Reference/Hearing Aid Compatibility Test (101x101x1):

Measurement grid: dx=5mm, dy=5mm

Maximum value of peak Total field = 173.7 V/m

Probe Modulation Factor = 2.62

Reference Value = 69.9 V/m; Power Drift = 0.045 dB

Hearing Aid Near-Field Category: M3 (AWF -5 dB)

Peak E-field in V/m

Grid 1	Grid 2	Grid 3
136.4	164.3	156.6
Grid 4	Grid 5	Grid 6
147.3	173.7	162.7
Grid 7	Grid 8	Grid 9
149.1	171.3	159.3

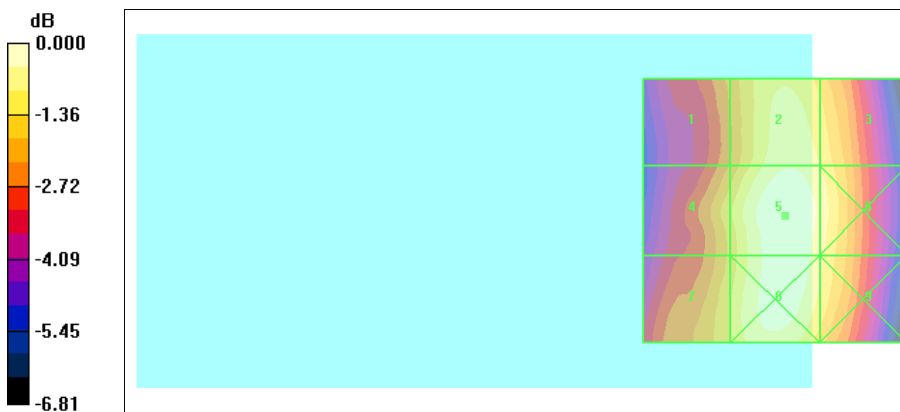

0 dB = 173.7V/m



Test Laboratory: A Test Lab Techno Corp. Date/Time: 5/30/2007 12:41:46 PM

HAC_GSM 850 CH251_E

DUT: MC3504; Type: PDA; FCC ID:H9PMC3504

Communication System: GSM850; Frequency: 848.8 MHz;Duty Cycle: 1:8.3

Medium parameters used: $\sigma = 0$ mho/m, $\epsilon_r = 1$; $\rho = 1000$ kg/m³

Phantom section: E Device Section

Measurement Standard: DASy4 (High Precision Assessment)

DASY4 Configuration:

- Probe: ER3DV6 - SN2302; ConvF(1, 1, 1); Calibrated: 3/21/2007
- Sensor-Surface: (Fix Surface)
- Electronics: DAE4 Sn541; Calibrated: 10/16/2006
- Phantom: HAC Test Arch; Type: SD HAC P01 BA; Serial:
- Measurement SW: DASy4, V4.7 Build 53; Postprocessing SW: SEMCAD, V1.8 Build 172

E Scan - ER3DV6 probe center 10mm above Device Reference/Hearing Aid Compatibility Test (101x101x1):

Measurement grid: dx=5mm, dy=5mm

Maximum value of peak Total field = 207.2 V/m

Probe Modulation Factor = 2.62

Reference Value = 81.4 V/m; Power Drift = -0.024 dB

Hearing Aid Near-Field Category: M3 (AWF -5 dB)

Peak E-field in V/m

Grid 1	Grid 2	Grid 3
161.8	195.0	185.0
Grid 4	Grid 5	Grid 6
177.3	207.2	193.4
Grid 7	Grid 8	Grid 9
181.2	205.6	189.7

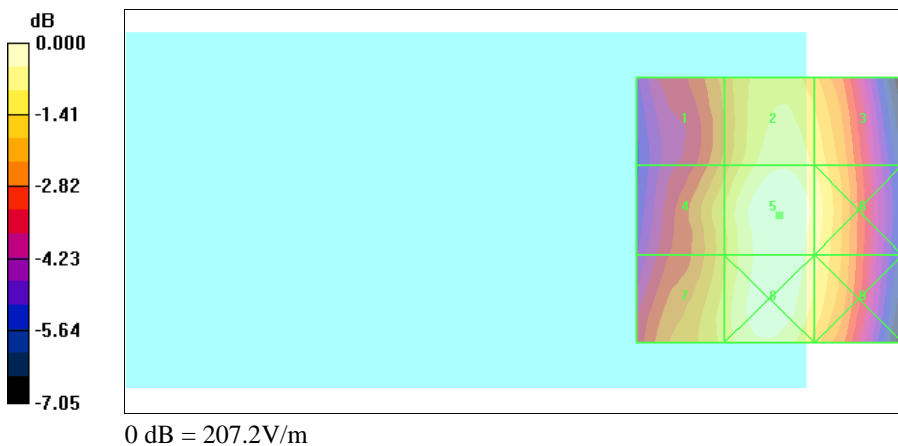



Test Laboratory: A Test Lab Techno Corp. Date/Time: 5/30/2007 12:02:34 PM

HAC_PCS CH512_E

DUT: MC3504; Type: PDA; FCC ID:H9PMC3504

Communication System: PCS; Frequency: 1850.2 MHz;Duty Cycle: 1:8.3

Medium parameters used: $\sigma = 0$ mho/m, $\epsilon_r = 1$; $\rho = 1000$ kg/m³

Phantom section: E Device Section

Measurement Standard: DAS4 (High Precision Assessment)

DASY4 Configuration:

- Probe: ER3DV6 - SN2302; ConvF(1, 1, 1); Calibrated: 3/21/2007
- Sensor-Surface: (Fix Surface)
- Electronics: DAE4 Sn541; Calibrated: 10/16/2006
- Phantom: HAC Test Arch; Type: SD HAC P01 BA; Serial:
- Measurement SW: DAS4, V4.7 Build 53; Postprocessing SW: SEMCAD, V1.8 Build 172

E Scan - ER3DV6 probe center 10mm above Device Reference/Hearing Aid Compatibility Test (101x101x1):

Measurement grid: dx=5mm, dy=5mm

Maximum value of peak Total field = 59.8 V/m

Probe Modulation Factor = 2.58

Reference Value = 22.2 V/m; Power Drift = -0.015 dB

Hearing Aid Near-Field Category: M3 (AWF -5 dB)

Peak E-field in V/m

Grid 1	Grid 2	Grid 3
50.3	54.2	46.0
Grid 4	Grid 5	Grid 6
53.0	59.8	54.9
Grid 7	Grid 8	Grid 9
68.6	64.4	57.6

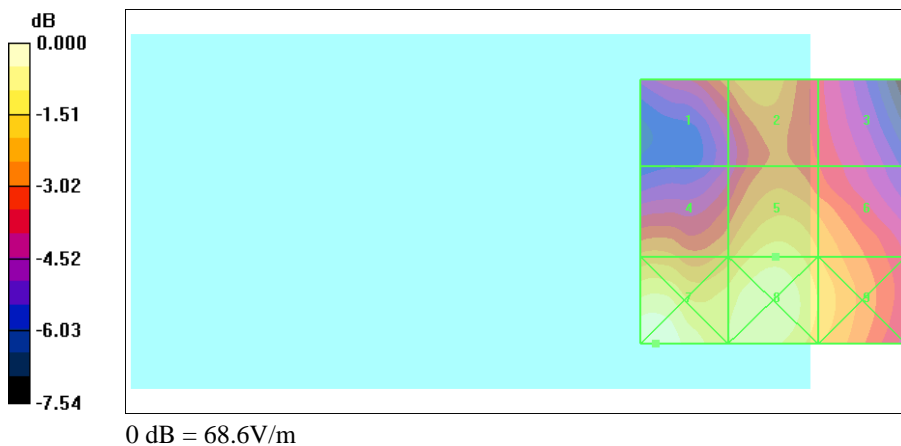



Test Laboratory: A Test Lab Techno Corp. Date/Time: 5/30/2007 12:08:22 PM

HAC_PCS CH661_E

DUT: MC3504; Type: PDA; FCC ID:H9PMC3504

Communication System: PCS; Frequency: 1880 MHz;Duty Cycle: 1:8.3

Medium parameters used: $\sigma = 0$ mho/m, $\epsilon_r = 1$; $\rho = 1000$ kg/m³

Phantom section: E Device Section

Measurement Standard: DAS4 (High Precision Assessment)

DASY4 Configuration:

- Probe: ER3DV6 - SN2302; ConvF(1, 1, 1); Calibrated: 3/21/2007
- Sensor-Surface: (Fix Surface)
- Electronics: DAE4 Sn541; Calibrated: 10/16/2006
- Phantom: HAC Test Arch; Type: SD HAC P01 BA; Serial:
- Measurement SW: DAS4, V4.7 Build 53; Postprocessing SW: SEMCAD, V1.8 Build 172

E Scan - ER3DV6 probe center 10mm above Device Reference/Hearing Aid Compatibility Test (101x101x1):

Measurement grid: dx=5mm, dy=5mm

Maximum value of peak Total field = 61.7 V/m

Probe Modulation Factor = 2.58

Reference Value = 23.1 V/m; Power Drift = -0.033 dB

Hearing Aid Near-Field Category: M3 (AWF -5 dB)

Peak E-field in V/m

Grid 1	Grid 2	Grid 3
53.0	57.8	48.2
Grid 4	Grid 5	Grid 6
54.3	61.7	56.5
Grid 7	Grid 8	Grid 9
70.5	66.3	59.0

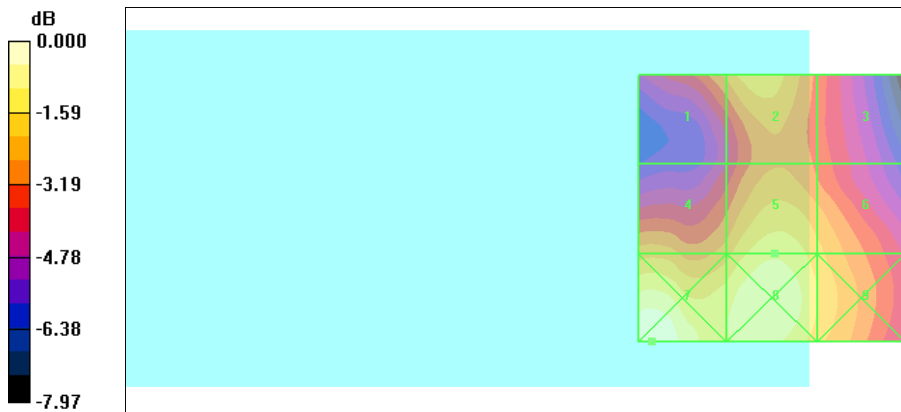

0 dB = 70.5V/m



Test Laboratory: A Test Lab Techno Corp. Date/Time: 5/30/2007 12:14:29 PM

HAC_PCS CH810_E

DUT: MC3504; Type: PDA; FCC ID:H9PMC3504

Communication System: PCS; Frequency: 1909.8 MHz;Duty Cycle: 1:8.3

Medium parameters used: $\sigma = 0$ mho/m, $\epsilon_r = 1$; $\rho = 1000$ kg/m³

Phantom section: E Device Section

Measurement Standard: DAS4 (High Precision Assessment)

DASY4 Configuration:

- Probe: ER3DV6 - SN2302; ConvF(1, 1, 1); Calibrated: 3/21/2007
- Sensor-Surface: (Fix Surface)
- Electronics: DAE4 Sn541; Calibrated: 10/16/2006
- Phantom: HAC Test Arch; Type: SD HAC P01 BA; Serial:
- Measurement SW: DAS4, V4.7 Build 53; Postprocessing SW: SEMCAD, V1.8 Build 172

E Scan - ER3DV6 probe center 10mm above Device Reference/Hearing Aid Compatibility Test (101x101x1):

Measurement grid: dx=5mm, dy=5mm

Maximum value of peak Total field = 70.2 V/m

Probe Modulation Factor = 2.58

Reference Value = 26.4 V/m; Power Drift = -0.056 dB

Hearing Aid Near-Field Category: M3 (AWF -5 dB)

Peak E-field in V/m

Grid 1	Grid 2	Grid 3
59.1	65.7	56.6
Grid 4	Grid 5	Grid 6
61.2	70.2	63.9
Grid 7	Grid 8	Grid 9
78.4	74.8	66.7

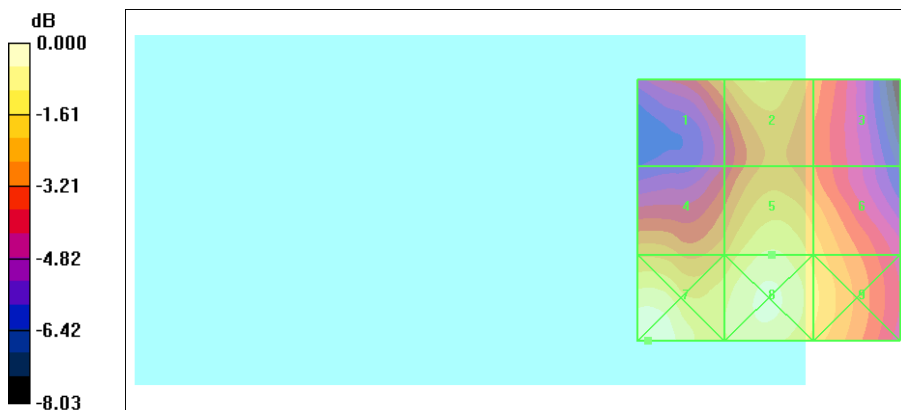

0 dB = 78.4V/m



Test Laboratory: A Test Lab Techno Corp. Date/Time: 5/30/2007 2:06:46 PM

HAC_GSM850 CH128_H

DUT: MC3504; Type: PDA; FCC ID:H9PMC3504

Communication System: GSM850; Frequency: 824.2 MHz;Duty Cycle: 1:8.3

Medium parameters used: $\sigma = 0$ mho/m, $\epsilon_r = 1$; $\rho = 1$ kg/m³

Phantom section: H Device Section

Measurement Standard: DAS4 (High Precision Assessment)

DASY4 Configuration:

- Probe: H3DV6 - SN6187; ; Calibrated: 3/21/2007
- Sensor-Surface: (Fix Surface)
- Electronics: DAE4 Sn541; Calibrated: 10/16/2006
- Phantom: HAC Test Arch; Type: SD HAC P01 BA; Serial:
- Measurement SW: DAS4, V4.7 Build 53; Postprocessing SW: SEMCAD, V1.8 Build 172

H Scan - H3DV6 probe center 10mm above Device Reference/Hearing Aid Compatibility Test (101x101x1):

Measurement grid: dx=5mm, dy=5mm

Maximum value of peak Total field = 0.372 A/m

Probe Modulation Factor = 2.73

Reference Value = 0.125 A/m; Power Drift = 0.022 dB

Hearing Aid Near-Field Category: M4 (AWF -5 dB)

Peak H-field in A/m

Grid 1	Grid 2	Grid 3
0.348	0.375	0.350
Grid 4	Grid 5	Grid 6
0.332	0.372	0.349
Grid 7	Grid 8	Grid 9
0.289	0.293	0.280

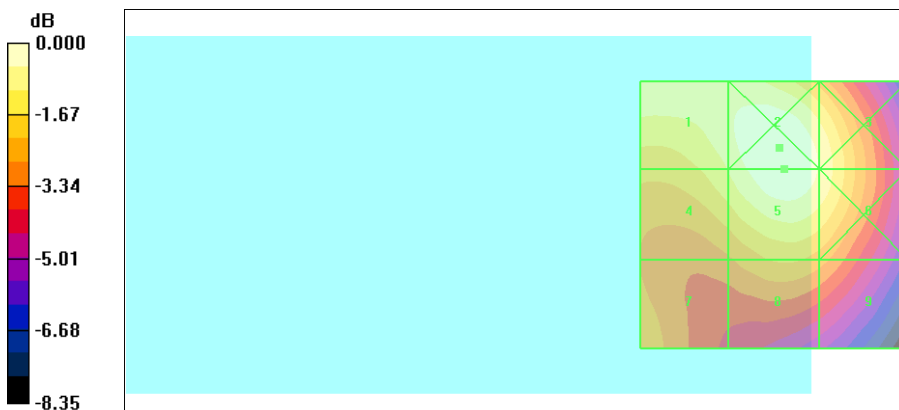

0 dB = 0.375A/m



Test Laboratory: A Test Lab Techno Corp. Date/Time: 5/30/2007 2:12:52 PM

HAC_GSM850 CH190_H

DUT: MC3504; Type: PDA; FCC ID:H9PMC3504

Communication System: GSM850; Frequency: 836.6 MHz;Duty Cycle: 1:8.3

Medium parameters used: $\sigma = 0$ mho/m, $\epsilon_r = 1$; $\rho = 1$ kg/m³

Phantom section: H Device Section

Measurement Standard: DAS4 (High Precision Assessment)

DASY4 Configuration:

- Probe: H3DV6 - SN6187; ; Calibrated: 3/21/2007
- Sensor-Surface: (Fix Surface)
- Electronics: DAE4 Sn541; Calibrated: 10/16/2006
- Phantom: HAC Test Arch; Type: SD HAC P01 BA; Serial:
- Measurement SW: DAS4, V4.7 Build 53; Postprocessing SW: SEMCAD, V1.8 Build 172

H Scan - H3DV6 probe center 10mm above Device Reference/Hearing Aid Compatibility Test (101x101x1):

Measurement grid: dx=5mm, dy=5mm

Maximum value of peak Total field = 0.457 A/m

Probe Modulation Factor = 2.73

Reference Value = 0.155 A/m; Power Drift = -0.012 dB

Hearing Aid Near-Field Category: M3 (AWF -5 dB)

Peak H-field in A/m

Grid 1	Grid 2	Grid 3
0.433	0.461	0.432
Grid 4	Grid 5	Grid 6
0.408	0.457	0.431
Grid 7	Grid 8	Grid 9
0.363	0.360	0.345

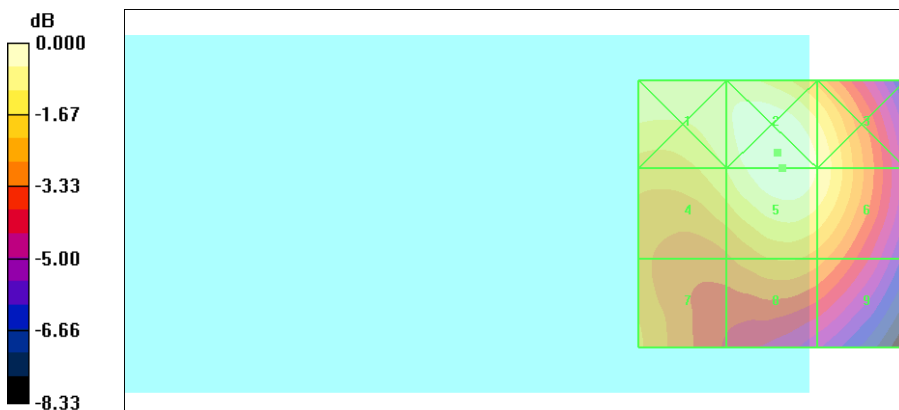

0 dB = 0.461A/m



Test Laboratory: A Test Lab Techno Corp. Date/Time: 5/30/2007 2:19:09 PM

HAC_GSM850 CH251_H

DUT: MC3504; Type: PDA; FCC ID:H9PMC3504

Communication System: GSM850; Frequency: 848.8 MHz; Duty Cycle: 1:8.3

Medium parameters used: $\sigma = 0$ mho/m, $\epsilon_r = 1$; $\rho = 1$ kg/m³

Phantom section: H Device Section

Measurement Standard: DAS4 (High Precision Assessment)

DASY4 Configuration:

- Probe: H3DV6 - SN6187; ; Calibrated: 3/21/2007
- Sensor-Surface: (Fix Surface)
- Electronics: DAE4 Sn541; Calibrated: 10/16/2006
- Phantom: HAC Test Arch; Type: SD HAC P01 BA; Serial:
- Measurement SW: DAS4, V4.7 Build 53; Postprocessing SW: SEMCAD, V1.8 Build 172

H Scan - H3DV6 probe center 10mm above Device Reference/Hearing Aid Compatibility Test (101x101x1):

Measurement grid: dx=5mm, dy=5mm

Maximum value of peak Total field = 0.539 A/m

Probe Modulation Factor = 2.73

Reference Value = 0.181 A/m; Power Drift = -0.197 dB

Hearing Aid Near-Field Category: M3 (AWF -5 dB)

Peak H-field in A/m

Grid 1	Grid 2	Grid 3
0.498	0.543	0.506
Grid 4	Grid 5	Grid 6
0.475	0.539	0.506
Grid 7	Grid 8	Grid 9
0.424	0.420	0.401

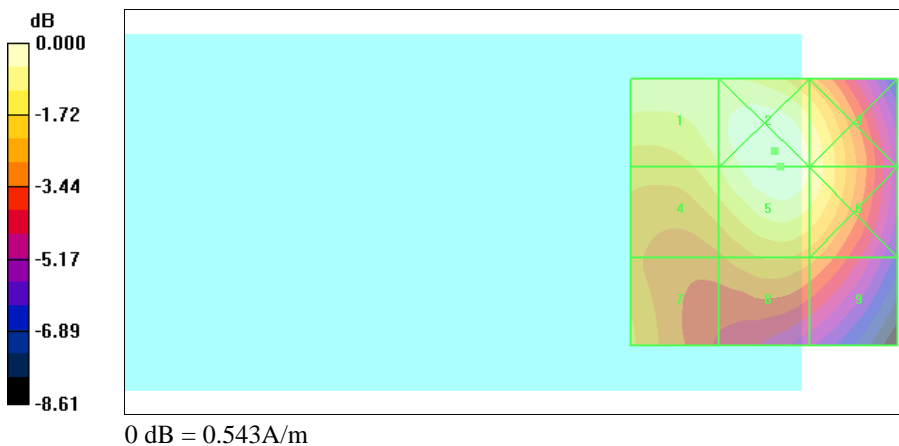



Test Laboratory: A Test Lab Techno Corp. Date/Time: 5/30/2007 1:44:52 PM

HAC_PCS CH 512_H

DUT: MC3504; Type: PDA; FCC ID:H9PMC3504

Communication System: PCS; Frequency: 1850.2 MHz;Duty Cycle: 1:8.3

Medium parameters used: $\sigma = 0$ mho/m, $\epsilon_r = 1$; $\rho = 1$ kg/m³

Phantom section: H Device Section

Measurement Standard: DAS4 (High Precision Assessment)

DASY4 Configuration:

- Probe: H3DV6 - SN6187; ; Calibrated: 3/21/2007
- Sensor-Surface: (Fix Surface)
- Electronics: DAE4 Sn541; Calibrated: 10/16/2006
- Phantom: HAC Test Arch; Type: SD HAC P01 BA; Serial:
- Measurement SW: DAS4, V4.7 Build 53; Postprocessing SW: SEMCAD, V1.8 Build 172

H Scan - H3DV6 probe center 10mm above Device Reference/Hearing Aid Compatibility Test (101x101x1):

Measurement grid: dx=5mm, dy=5mm

Maximum value of peak Total field = 0.212 A/m

Probe Modulation Factor = 2.40

Reference Value = 0.090 A/m; Power Drift = -0.102 dB

Hearing Aid Near-Field Category: M3 (AWF -5 dB)

Peak H-field in A/m

Grid 1	Grid 2	Grid 3
0.194	0.211	0.196
Grid 4	Grid 5	Grid 6
0.194	0.212	0.201
Grid 7	Grid 8	Grid 9
0.180	0.202	0.193



0 dB = 0.212A/m



Test Laboratory: A Test Lab Techno Corp. Date/Time: 5/30/2007 1:50:13 PM

HAC_PCS CH 661_H

DUT: MC3504; Type: PDA; FCC ID:H9PMC3504

Communication System: PCS; Frequency: 1880 MHz;Duty Cycle: 1:8.3

Medium parameters used: $\sigma = 0$ mho/m, $\epsilon_r = 1$; $\rho = 1$ kg/m³

Phantom section: H Device Section

Measurement Standard: DAS4 (High Precision Assessment)

DASY4 Configuration:

- Probe: H3DV6 - SN6187; ; Calibrated: 3/21/2007
- Sensor-Surface: (Fix Surface)
- Electronics: DAE4 Sn541; Calibrated: 10/16/2006
- Phantom: HAC Test Arch; Type: SD HAC P01 BA; Serial:
- Measurement SW: DAS4, V4.7 Build 53; Postprocessing SW: SEMCAD, V1.8 Build 172

H Scan - H3DV6 probe center 10mm above Device Reference/Hearing Aid Compatibility Test (101x101x1):

Measurement grid: dx=5mm, dy=5mm

Maximum value of peak Total field = 0.217 A/m

Probe Modulation Factor = 2.40

Reference Value = 0.092 A/m; Power Drift = -0.017 dB

Hearing Aid Near-Field Category: M3 (AWF -5 dB)

Peak H-field in A/m

Grid 1	Grid 2	Grid 3
0.201	0.216	0.201
Grid 4	Grid 5	Grid 6
0.201	0.217	0.206
Grid 7	Grid 8	Grid 9
0.188	0.207	0.197



0 dB = 0.217A/m



Test Laboratory: A Test Lab Techno Corp. Date/Time: 5/30/2007 1:55:33 PM

HAC_PCS CH 810_H

DUT: MC3504; Type: PDA; FCC ID:H9PMC3504

Communication System: PCS; Frequency: 1909.8 MHz;Duty Cycle: 1:8.3

Medium parameters used: $\sigma = 0$ mho/m, $\epsilon_r = 1$; $\rho = 1$ kg/m³

Phantom section: H Device Section

Measurement Standard: DAS4 (High Precision Assessment)

DASY4 Configuration:

- Probe: H3DV6 - SN6187; ; Calibrated: 3/21/2007
- Sensor-Surface: (Fix Surface)
- Electronics: DAE4 Sn541; Calibrated: 10/16/2006
- Phantom: HAC Test Arch; Type: SD HAC P01 BA; Serial:
- Measurement SW: DAS4, V4.7 Build 53; Postprocessing SW: SEMCAD, V1.8 Build 172

H Scan - H3DV6 probe center 10mm above Device Reference/Hearing Aid Compatibility Test (101x101x1):

Measurement grid: dx=5mm, dy=5mm

Maximum value of peak Total field = 0.239 A/m

Probe Modulation Factor = 2.40

Reference Value = 0.101 A/m; Power Drift = 0.007 dB

Hearing Aid Near-Field Category: M3 (AWF -5 dB)

Peak H-field in A/m

Grid 1	Grid 2	Grid 3
0.221	0.237	0.225
Grid 4	Grid 5	Grid 6
0.221	0.239	0.230
Grid 7	Grid 8	Grid 9
0.207	0.229	0.221



0 dB = 0.239A/m



Appendix E - Calibration

All of the instruments Calibration information are listed below.

- Dipole _ CD835V3 SN:1052 Calibration No.CD835V3-1052_Jan06
- Dipole _ CD1880V3 SN:1044 Calibration No.CD1880V3-1044_ Jan06
- Probe _ ER3DV6 SN: 2302 Calibration No. ER3-2302_Mar07
- Probe _ H3DV6 SN: 6187 Calibration No. H3-6187_ Mar07
- DAE _ DAE4 SN:541 Calibration No.DAE4-541_Oct06