

Supplementary FCC Test Report

Report No.: RF140609E04B R1

FCC ID: H9PMC18N0

Test Model: MC18N0

Received Date: Jan. 28, 2015

Test Date: Feb. 05 to Mar. 09, 2015

Issued Date: May 07, 2015

Applicant: Symbol Technologies, Inc.

Address: 1 Zebra Plaza Holtsville, NY 11742

Manufacturer: Symbol Technologies, Inc.

Address: 1 Zebra Plaza Holtsville, NY 11742

Issued By: Bureau Veritas Consumer Products Services (H.K.) Ltd., Taoyuan Branch
Hsin Chu Laboratory

Lab Address: No. 81-1, Lu Liao Keng, 9th Ling,Wu Lung Tsuen, Chiung Lin Hsiang, Hsin
Chu Hsien 307, Taiwan R.O.C.

Test Location (1): No. 81-1, Lu Liao Keng, 9th Ling,Wu Lung Tsuen, Chiung Lin Hsiang, Hsin
Chu Hsien 307, Taiwan R.O.C.

Test Location (2): No. 49, Ln. 206, Wende Rd., Shangshan Tsuen, Chiung Lin Hsiang, Hsin
Chu Hsien 307, Taiwan R.O.C.



This report is for your exclusive use. Any copying or replication of this report to or for any other person or entity, or use of our name or trademark, is permitted only with our prior written permission. This report sets forth our findings solely with respect to the test samples identified herein. The results set forth in this report are not indicative or representative of the quality or characteristics of the lot from which a test sample was taken or any similar or identical product unless specifically and expressly noted. Our report includes all of the tests requested by you and the results thereof based upon the information that you provided to us. You have 60 days from date of issuance of this report to notify us of any material error or omission caused by our negligence, provided, however, that such notice shall be in writing and shall specifically address the issue you wish to raise. A failure to raise such issue within the prescribed time shall constitute your unqualified acceptance of the completeness of this report, the tests conducted and the correctness of the report contents. Unless specific mention, the uncertainty of measurement has been explicitly taken into account to declare the compliance or non-compliance to the specification. The report must not be used by the client to claim product certification, approval, or endorsement by TAF or any government agencies.



Table of Contents

Report Issue History Record of EUT (MC18N0)..... 4

Release Control Record..... 4

1 Certificate of Conformity..... 5

2 Summary of Test Results 6

2.1 Measurement Uncertainty 7

2.2 Modification Record 7

3 General Information..... 8

3.1 General Description of EUT 8

3.2 Description of Test Modes 10

3.2.1 Test Mode Applicability and Tested Channel Detail..... 11

3.3 Duty Cycle of Test Signal 13

3.4 Description of Support Units 14

3.4.1 Configuration of System under Test 14

3.5 General Description of Applied Standards 15

4 Test Types and Results 16

4.1 Radiated Emission and Bandedge Measurement..... 16

4.1.1 Limits of Radiated Emission and Bandedge Measurement 16

4.1.2 Test Instruments 17

4.1.3 Test Procedures..... 19

4.1.4 Deviation from Test Standard 19

4.1.5 Test Setup..... 20

4.1.6 EUT Operating Conditions..... 21

4.1.7 Test Results 22

4.2 Transmit Power Measurement 34

4.2.1 Limits of Transmit Power Measurement 34

4.2.2 Test Setup..... 34

4.2.3 Test Instruments 34

4.2.4 Test Procedures..... 34

4.2.5 Deviation from Test Standard 34

4.2.6 EUT Operating Conditions..... 34

4.2.7 Test Result..... 35

4.3 Peak Power Spectral Density Measurement 37

4.3.1 Limits of Peak Power Spectral Density Measurement 37

4.3.2 Test Setup..... 37

4.3.3 Test Instruments 37

4.3.4 Test Procedures..... 37

4.3.5 Deviation from Test Standard 37

4.3.6 EUT Operating Conditions..... 37

4.3.7 Test Results 38

4.4 Frequency Stability Measurement 39

4.4.1 Limits of Frequency Stability Measurement 39

4.4.2 Test Setup..... 39

4.4.3 Test Instruments 39

4.4.4 Test Procedures..... 39

4.4.5 Deviation from Test Standard 39

4.4.6 EUT Operating Conditions..... 39

4.4.7 Test Results 40

4.5 6dB Bandwidth Measurement..... 41

4.5.1 Limits of 6dB Bandwidth Measurement..... 41

4.5.2 Test Setup..... 41

4.5.3 Test Instruments 41

4.5.4 Test Procedures..... 41



4.5.5 Deviation from Test Standard 41

4.5.6 EUT Operating Conditions..... 41

4.5.7 Test Results 42

5 Pictures of Test Arrangements..... 43

Appendix – Information on the Testing Laboratories 44



Report Issue History Record of EUT (MC18N0)

Attachment No.	Issue Date	Description
140609E04	July 29, 2014	Original
140609E04B R1	Mar. 25, 2015	Upgrade the versions of the standard to section 15.407 under new rule

Release Control Record

Issue No.	Description	Date Issued
RF140609E04B	Original release.	Mar. 25, 2015
RF140609E04B R1	Modified the applicant address and Manufacturer address.	May 07, 2015

2 Summary of Test Results

47 CFR FCC Part 15, Subpart E (SECTION 15.407 Under New Rule)			
FCC Clause	Test Item	Result	Remarks
15.407(b) (1/2/3/4/6)	Radiated Emissions & Band Edge Measurement	PASS	Meet the requirement of limit. Minimum passing margin is -1.1dB at 5725.00MHz.
15.407(a)(1/2 /3)	Max Average Transmit Power	PASS	Meet the requirement of limit.
15.407(a)(1/2 /3)	Peak Power Spectral Density	PASS	Meet the requirement of limit.
15.407(e)	6dB bandwidth	PASS	Meet the requirement of limit. (U-NII-3 Band only)
15.407(g)	Frequency Stability	PASS	Meet the requirement of limit.
15.203	Antenna Requirement	PASS	No antenna connector is used.

- NOTE:**
1. For WLAN: The EUT was operating in 2400~2483.5MHz, 5.15~5.35GHz, 5.47~5.725GHz and 5.725~5.850GHz frequencies band. This report was recorded the RF parameters including 5.725~5.850GHz.
 2. The DFS report was recorded in another test report.
 3. This report is prepared for FCC Class II change. (Upgrade the versions of the standard to section 15.407 under new rule).

2.1 Measurement Uncertainty

Where relevant, the following measurement uncertainty levels have been estimated for tests performed on the EUT as specified in CISPR 16-4-2:

Measurement	Frequency	Expanded Uncertainty (k=2) (\pm)
Radiated Emissions up to 1 GHz	30MHz ~ 1000MHz	5.37 dB
Radiated Emissions above 1 GHz	1GHz ~ 6GHz	3.72 dB
	6GHz ~ 18GHz	4.00 dB
	18GHz ~ 40GHz	4.11 dB

2.2 Modification Record

There were no modifications required for compliance.

3 General Information

3.1 General Description of EUT

Product	MC18 Personal Shopper - Barcode Scanner
Brand	Symbol
Test Model	MC18N0
Status of EUT	MASS-PRODUCTION
Power Supply Rating	DC 3.7V from battery
Modulation Type	CCK, DQPSK, DBPSK for DSSS 64QAM, 16QAM, QPSK, BPSK for OFDM
Modulation Technology	DSSS, OFDM
Transfer Rate	802.11b: up to 11Mbps 802.11g / a: up to 54Mbps 802.11n (HT20): up to 72.2Mbps
Operating Frequency	For 15.407 5.18 ~ 5.24GHz, 5.26 ~ 5.32GHz, 5.5~5.825GHz For 15.247 2.412 ~ 2.472GHz
Number of Channel	For 15.407 24 for 802.11a, 802.11n (HT20) For 15.247 13 for 802.11b, 802.11g, 802.11n (HT20)
Output Power	802.11a: 42.855 mW 802.11n (HT20): 41.115mW
Antenna Type	Please see Note
Antenna Connector	Please see Note
Accessory Device	NA
Data Cable Supplied	NA

Note:

- This report is prepared for FCC Class II change. The difference compared with the Report No.: RF140609E04 design is as the following:
 - ◆ Upgrade the versions of the standard to section 15.407 under new rule
- According to above conditions, all test items of U-NII band 3 and Dynamic Frequency Selection test item need to be performed (except for Conducted Emission test item). And all data was verified to meet the requirements.
- There are Bluetooth 4.0 technology and WLAN 802.11 a/b/g/n technology.
- For WLAN: 2.4GHz and 5GHz technology cannot transmit at same time.
- 2.4GHz/5GHz WLAN + BT will timely shared at same antenna port
- The antennas provided to the EUT, please refer to the following table:

Antenna Type	Antenna Gain(dBi)	Frequency range(MHz to MHz)	Connector Type	Cable Length
PIFA	2.7	2412~2483.5	NA	NA
	3	5150~5850		

7. The Version of EUT information are as below:

HW	Terminal	MC18 MB V2.1
SW	System	WinCE
	OS Name	Symbol MC18
	OS version	07.00.2824
	OEM version	99.45.10
	Part Number	31-FUSION-X2.01
Wireless (Fusion)	Fusion version	X_2.01.0.0.074R
	WLAN Firmware	X_2.01.0.0.180
	Version	X_2.01.0.0.3
XW2DMT (WLAN RF)	Symbol version	X_2.01.0.0.171
	WLAN Firmware	X_2.01.0.0.180
	Version	4.1
BTRegTest (WLAN BT)	Version	4.1

8. The associated devices of EUT information are as below:

Product	P/N
Y Power Cable	P/N : CBL-MC18-Y2MET-01
DC Power Cable	P/N : 25-66420-01R
Interconnect Cable	P/N : 25-66431-01R
Programming Cable	P/N : CBL-MC18-USB1-01
Cold Boot Key	P/N : KT-MC18-RBOOT-05

9. The EUT could be supplied with the a power adapter and/or Li-ion battery as below:

Li-ion Battery	
Brand:	Symbol
Part No.:	BT000018A01
Rating:	3.7V, 2725mAh, 10.08Wh

10. The EUT incorporates a SISO function.

MODULATION MODE	DATA RATE (MCS)	TX & RX CONFIGURATION	
802.11a	6 ~ 54Mbps	1TX	1RX
802.11b	1 ~ 11Mbps	1TX	1RX
802.11g	6 ~ 54Mbps	1TX	1RX
802.11n (HT20)	MCS 0~7	1TX	1RX

11. The above EUT information is declared by manufacturer and for more detailed features description, please refer to the manufacturer's specifications or user's manual.

3.2 Description of Test Modes

FOR 5745 ~ 5825MHz

5 channels are provided for 802.11a, 802.11n (HT20):

Channel	Frequency	Channel	Frequency
149	5745MHz	161	5805MHz
153	5765MHz	165	5825MHz
157	5785MHz		

3.2.1 Test Mode Applicability and Tested Channel Detail

EUT CONFIGURE MODE	APPLICABLE TO			DESCRIPTION
	RE \geq 1G	RE<1G	APCM	
-	√	√	√	-

Where **RE \geq 1G**: Radiated Emission above 1GHz **RE<1G**: Radiated Emission below 1GHz
APCM: Antenna Port Conducted Measurement

NOTE:

1. The test mode was reference to the worst case in the original test report.

Radiated Emission Test (Above 1GHz):

- Pre-Scan has been conducted to determine the worst-case mode from all possible combinations between available modulations, data rates and antenna ports (if EUT with antenna diversity architecture).
- Following channel(s) was (were) selected for the final test as listed below.

MODE	FREQ. BAND (MHz)	AVAILABLE CHANNEL	TESTED CHANNEL	MODULATION TECHNOLOGY	MODULATION TYPE	DATA RATE (Mbps)
802.11a	5745-5825	149 to 165	149, 157, 165	OFDM	BPSK	6
802.11n (HT20)		149 to 165	149, 157, 165	OFDM	BPSK	6.5

Radiated Emission Test (Below 1GHz):

- Pre-Scan has been conducted to determine the worst-case mode from all possible combinations between available modulations, data rates and antenna ports (if EUT with antenna diversity architecture).
- Following channel(s) was (were) selected for the final test as listed below.

MODE	FREQ. BAND (MHz)	AVAILABLE CHANNEL	TESTED CHANNEL	MODULATION TECHNOLOGY	MODULATION TYPE	DATA RATE (Mbps)
802.11a	5745-5825	149 to 165	149, 157, 165	OFDM	BPSK	6
802.11n (HT20)		149 to 165	149, 157, 165	OFDM	BPSK	6.5

Antenna Port Conducted Measurement:

- This item includes all test value of each mode, but only includes spectrum plot of worst value of each mode.
- Pre-Scan has been conducted to determine the worst-case mode from all possible combinations between available modulations, data rates and antenna ports (if EUT with antenna diversity architecture).
- Following channel(s) was (were) selected for the final test as listed below.

MODE	FREQ. BAND (MHz)	AVAILABLE CHANNEL	TESTED CHANNEL	MODULATION TECHNOLOGY	MODULATION TYPE	DATA RATE (Mbps)
802.11a	5745-5825	149 to 165	149, 157, 165	OFDM	BPSK	6
802.11n (HT20)		149 to 165	149, 157, 165	OFDM	BPSK	6.5

**Test Condition:**

APPLICABLE TO	ENVIRONMENTAL CONDITIONS	INPUT POWER	TESTED BY
RE \geq 1G	23deg. C, 71%RH	120Vac, 60Hz	Tim Ho
RE $<$ 1G	25deg. C, 65%RH	120Vac, 60Hz	Andy Ho
APCM	25deg. C, 60%RH	120Vac, 60Hz	Andy Ho

3.3 Duty Cycle of Test Signal

Duty cycle of test signal is $\geq 98\%$, duty factor is not required.

802.11a: Duty cycle = $1.426 \text{ ms} / 1.54 \text{ ms} = 0.926$, Duty factor = $10 * \log(1/0.926) = 0.33$

802.11n (HT20): Duty cycle = $1.205 \text{ ms} / 1.323 \text{ ms} = 0.911$, Duty factor = $10 * \log(1/0.911) = 0.41$

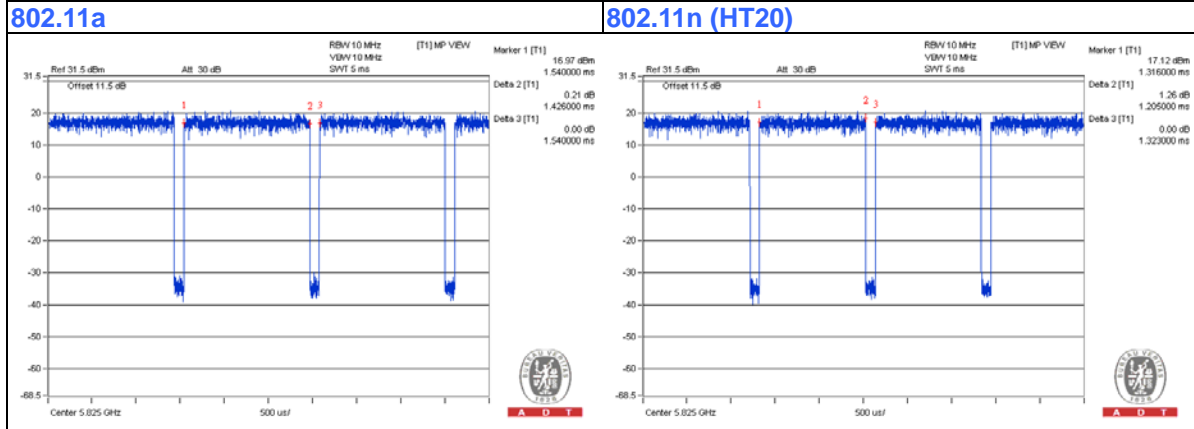

3.4 Description of Support Units

The EUT has been tested as an independent unit.

3.4.1 Configuration of System under Test

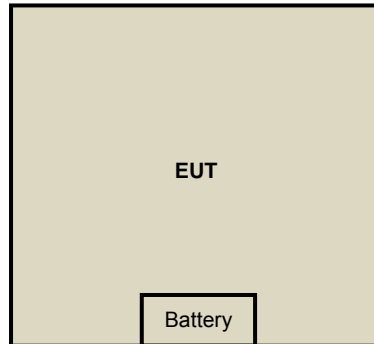

3.5 General Description of Applied Standards

The EUT is a RF Product. According to the specifications of the manufacturer, it must comply with the requirements of the following standards:

FCC Part 15, Subpart E (15.407)

789033 D02 General UNII Test Procedures New Rules v01

ANSI C63.10-2009

All test items have been performed and recorded as per the above standards.

Note: The EUT has been verified to comply with the requirements of FCC Part 15, Subpart B, Class B (DoC). The test report has been issued separately.

4 Test Types and Results

4.1 Radiated Emission and Bandedge Measurement

4.1.1 Limits of Radiated Emission and Bandedge Measurement

Radiated emissions which fall in the restricted bands must comply with the radiated emission limits specified as below table.

Frequencies (MHz)	Field Strength (microvolts/meter)	Measurement Distance (meters)
0.009 ~ 0.490	2400/F(kHz)	300
0.490 ~ 1.705	24000/F(kHz)	30
1.705 ~ 30.0	30	30
30 ~ 88	100	3
88 ~ 216	150	3
216 ~ 960	200	3
Above 960	500	3

NOTE:

1. The lower limit shall apply at the transition frequencies.
2. Emission level (dBuV/m) = 20 log Emission level (uV/m).
3. For frequencies above 1000MHz, the field strength limits are based on average detector, however, the peak field strength of any emission shall not exceed the maximum permitted average limits, specified above by more than 20dB under any condition of modulation.

LIMITS OF UNWANTED EMISSION OUT OF THE RESTRICTED BANDS

APPLICABLE TO	LIMIT	
789033 D02 General UNII Test Procedures New Rules v01	FIELD STRENGTH AT 3m	
	PK:74 (dBuV/m)	AV:54 (dBuV/m)
APPLICABLE TO	EIRP LIMIT	EQUIVALENT FIELD STRENGTH AT 3m
15.407(b)(1)	PK:-27 (dBm/MHz)	PK:68.2(dBuV/m)
15.407(b)(2)		
15.407(b)(3)		
15.407(b)(4)	PK:-27 (dBm/MHz) ^{*1} PK:-17 (dBm/MHz) ^{*2}	PK: 68.2(dBuV/m) ^{*1} PK:78.2 (dBuV/m) ^{*2}

NOTE: ^{*1} beyond 10MHz of the band edge ^{*2} within 10 MHz of band edge

The following formula is used to convert the equipment isotropic radiated power (eirp) to field strength:

$$E = \frac{1000000\sqrt{30P}}{3} \mu\text{V/m, where P is the eirp (Watts).}$$

**4.1.2 Test Instruments
FOR POWER OUTPUT MEASUREMENT**

DESCRIPTION & MANUFACTURER	MODEL NO.	SERIAL NO.	CALIBRATED DATE	CALIBRATED UNTIL
Power meter Anritsu	ML2495A	1014008	Apr. 30, 2014	Apr. 29, 2015
Power sensor Anritsu	MA2411B	0917122	Apr. 30, 2014	Apr. 29, 2015

Note:

1. The calibration interval of the above test instruments is 12 months and the calibrations are traceable to NML/ROC and NIST/USA.
2. Tested date : Mar. 05, 2015

FOR RADIATED EMISSION AND BANDEDGE MEASUREMENT
For Above 1GHz:

DESCRIPTION & MANUFACTURER	MODEL NO.	SERIAL NO.	CALIBRATED DATE	CALIBRATED UNTIL
MXE EMI Receiver Agilent	N9038A	MY50010156	Aug. 11, 2014	Aug. 10, 2015
Pre-Amplifier Mini-Circuits	ZFL-1000VH2 B	AMP-ZFL-04	Nov. 12, 2014	Nov. 11, 2015
Trilog Broadband Antenna SCHWARZBECK	VULB 9168	9168-361	Feb. 27, 2014	Feb. 26, 2015
RF Cable	NA	CHHCAB_001	Oct. 05, 2014	Oct. 04, 2015
Horn_Antenna AISI	AIH.8018	0000220091110	Aug. 26, 2014	Aug. 25, 2015
Pre-Amplifier Agilent	8449B	300801923	Oct. 28, 2014	Oct. 27, 2015
RF Cable	NA	131206 131215 SNMY23685/4	Jan. 16, 2015	Jan. 15, 2016
Spectrum Analyzer R&S	FSV40	100964	July 05, 2014	July 04, 2015
Pre-Amplifier EMCI	EMC184045	980143	Jan. 16, 2015	Jan. 15, 2016
Horn_Antenna SCHWARZBECK	BBHA 9170	9170-424	Aug. 26, 2014	Aug. 25, 2015
RF Cable	NA	RF104-121 RF104-204	Dec. 11, 2014	Dec. 10, 2015
Software	ADT_Radiated _V8.7.07	NA	NA	NA
Antenna Tower & Turn Table CT	NA	NA	NA	NA

Note:

1. The calibration interval of the above test instruments is 12 months and the calibrations are traceable to NML/ROC and NIST/USA.
2. The horn antenna, preamplifier (model: 8449B) are used only for the measurement of emission frequency above 1GHz if tested.
3. The test was performed in 966 Chamber No. H.
4. The FCC Site Registration No. is 797305.
5. The CANADA Site Registration No. is IC 7450H-3.
6. Tested Date: Feb. 05, 2015

For Below 1GHz:

DESCRIPTION & MANUFACTURER	MODEL NO.	SERIAL NO.	CALIBRATED DATE	CALIBRATED UNTIL
MXE EMI Receiver Agilent	N9038A	MY51210105	July 21,2014	July 20,2015
Pre-Amplifier Mini-Circuits	ZFL-1000VH2 B	AMP-ZFL-03	Nov. 12, 2014	Nov. 11, 2015
Trilog Broadband Antenna SCHWARZBECK	VULB 9168	9168-360	Feb. 06, 2015	Feb. 05, 2016
RF Cable	NA	CHGCAB_001	Oct. 04, 2014	Oct. 03, 2015
Horn_Antenna AISI	AIH.8018	0000320091110	Aug. 27, 2014	Aug. 26, 2015
Pre-Amplifier Agilent	8449B	3008A02578	June 24, 2014	June 23, 2015
RF Cable	NA	131205 131214 SNMY23684/4	Jan. 16, 2015	Jan. 15, 2016
Spectrum Analyzer R&S	FSV40	100964	July 05, 2014	July 04, 2015
Pre-Amplifier EMCI	EMC184045	980143	Jan. 16, 2015	Jan. 15, 2016
Horn_Antenna SCHWARZBECK	BBHA 9170	9170-424	Aug. 26, 2014	Aug. 25, 2015
RF Cable	NA	RF104-121 RF104-204	Dec. 11, 2014	Dec. 10, 2015
Antenna Tower & Turn Table CT	NA	NA	NA	NA

Note:

1. The calibration interval of the above test instruments is 12 months and the calibrations are traceable to NML/ROC and NIST/USA.
2. The horn antenna, preamplifier (model: 8449B) are used only for the measurement of emission frequency above 1GHz if tested.
3. The test was performed in 966 Chamber No. G.
4. The FCC Site Registration No. is 966073.
5. The VCCI Site Registration No. is G-137.
6. The CANADA Site Registration No. is IC 7450H-2.
7. Tested Date: Mar. 09, 2015

4.1.3 Test Procedures

- a. The EUT was placed on the top of a rotating table 0.8 meters above the ground at 3 meter chamber room for test. The table was rotated 360 degrees to determine the position of the highest radiation.
- b. The EUT was set 3 meters away from the interference-receiving antenna, which was mounted on the top of a variable-height antenna tower.
- c. The height of antenna is varied from one meter to four meters above the ground to determine the maximum value of the field strength. Both horizontal and vertical polarizations of the antenna are set to make the measurement.
- d. For each suspected emission, the EUT was arranged to its worst case and then the antenna was tuned to heights from 1 meter to 4 meters and the rotatable table was turned from 0 degrees to 360 degrees to find the maximum reading.
- e. The test-receiver system was set to quasi-peak detect function and specified bandwidth with maximum hold mode when the test frequency is below 1 GHz.
- f. The test-receiver system was set to peak and average detect function and specified bandwidth with maximum hold mode when the test frequency is above 1 GHz. If the peak reading value also meets average limit, measurement with the average detector is unnecessary.

Note:

1. The resolution bandwidth and video bandwidth of test receiver/spectrum analyzer is 120kHz for Quasi-peak detection (QP) at frequency below 1GHz.
2. The resolution bandwidth of test receiver/spectrum analyzer is 1 MHz and the video bandwidth is 3 MHz for Peak detection (PK) at frequency above 1GHz.
3. The resolution bandwidth of test receiver/spectrum analyzer is 1MHz and the video bandwidth is 3MHz for RMS Average (Duty cycle < 98%) for Average detection (AV) at frequency above 1GHz, then the measurement results was added to a correction factor ($10 \log(1/\text{duty cycle})$).
4. The resolution bandwidth of test receiver/spectrum analyzer is 1MHz and the video bandwidth is 10Hz (Duty cycle $\geq 98\%$) for Average detection (AV) at frequency above 1GHz.
5. All modes of operation were investigated and the worst-case emissions are reported.

4.1.4 Deviation from Test Standard

No deviation.

4.1.5 Test Setup

<Frequency Range below 1GHz>

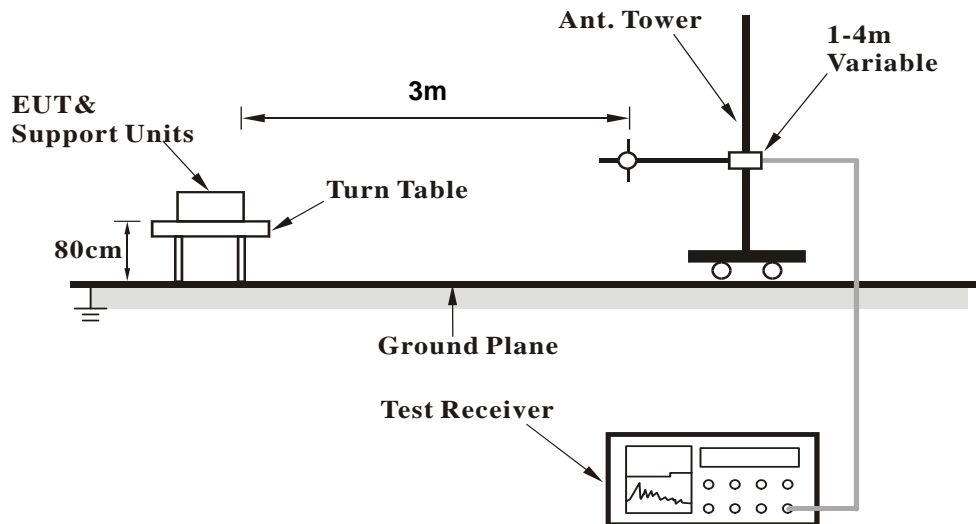

<Frequency Range above 1GHz>

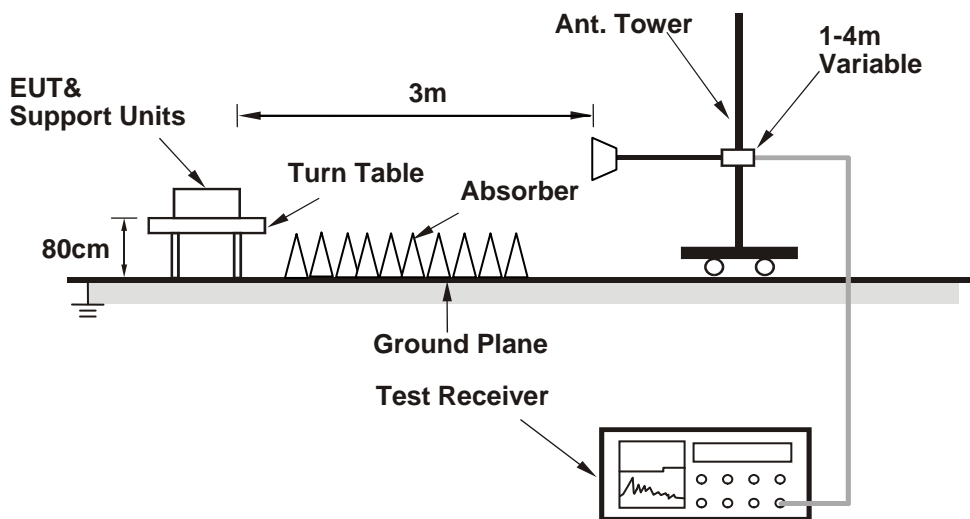

For the actual test configuration, please refer to the attached file (Test Setup Photo).



4.1.6 EUT Operating Conditions

1. The EUT runs test program “XW2DMT[X_2.01.0.0.3]” to enable EUT under transmission/receiving condition continuously at specific channel frequency.

4.1.7 Test Results

Above 1GHz Data

802.11a

CHANNEL	TX Channel 149	DETECTOR FUNCTION	Peak (PK)
FREQUENCY RANGE	1GHz ~ 40GHz		Average (AV)

ANTENNA POLARITY & TEST DISTANCE: HORIZONTAL AT 3 M

NO.	FREQ. (MHz)	EMISSION LEVEL (dBuV/m)	LIMIT (dBuV/m)	MARGIN (dB)	ANTENNA HEIGHT (m)	TABLE ANGLE (Degree)	RAW VALUE (dBuV)	CORRECTION FACTOR (dB/m)
1	#5715.00	67.8 PK	74.0	-6.2	1.37 H	282	62.90	4.90
2	#5715.00	49.5 AV	54.0	-4.5	1.37 H	282	44.60	4.90
3	#5725.00	77.1 PK	78.2	-1.1	1.40 H	281	72.17	4.93
4	*5745.00	114.3 PK			1.38 H	275	109.38	4.92
5	*5745.00	102.4 AV			1.38 H	275	97.48	4.92
6	11490.00	55.4 PK	74.0	-18.6	1.04 H	360	44.75	10.65
7	11490.00	45.2 AV	54.0	-8.8	1.04 H	360	34.55	10.65
8	#17235.00	60.6 PK	74.0	-13.4	1.00 H	250	41.15	19.45
9	#17235.00	50.7 AV	54.0	-3.3	1.00 H	250	31.25	19.45

ANTENNA POLARITY & TEST DISTANCE: VERTICAL AT 3 M

NO.	FREQ. (MHz)	EMISSION LEVEL (dBuV/m)	LIMIT (dBuV/m)	MARGIN (dB)	ANTENNA HEIGHT (m)	TABLE ANGLE (Degree)	RAW VALUE (dBuV)	CORRECTION FACTOR (dB/m)
1	#5715.00	64.7 PK	74.0	-9.3	1.29 V	93	59.80	4.90
2	#5715.00	46.2 AV	54.0	-7.8	1.29 V	93	41.30	4.90
3	#5725.00	69.5 PK	78.2	-8.7	1.29 V	93	64.57	4.93
4	*5745.00	109.3 PK			1.27 V	92	104.38	4.92
5	*5745.00	97.8 AV			1.27 V	92	92.88	4.92
6	11490.00	55.7 PK	74.0	-18.3	1.04 V	220	45.05	10.65
7	11490.00	43.9 AV	54.0	-10.1	1.04 V	220	33.25	10.65
8	#17235.00	61.0 PK	74.0	-13.0	1.22 V	14	41.55	19.45
9	#17235.00	50.8 AV	54.0	-3.2	1.22 V	14	31.35	19.45

REMARKS:

1. Emission Level(dBuV/m) = Raw Value(dBuV) + Correction Factor(dB/m)
2. Correction Factor(dB/m) = Antenna Factor(dB/m) + Cable Factor(dB) – Pre-Amplifier Factor(dB)
3. The other emission levels were very low against the limit.
4. Margin value = Emission Level – Limit value
5. " * ": Fundamental frequency.
6. " # ": The radiated frequency is out of the restricted band.

CHANNEL	TX Channel 157	DETECTOR FUNCTION	Peak (PK)
FREQUENCY RANGE	1GHz ~ 40GHz		Average (AV)

ANTENNA POLARITY & TEST DISTANCE: HORIZONTAL AT 3 M

NO.	FREQ. (MHz)	EMISSION LEVEL (dBuV/m)	LIMIT (dBuV/m)	MARGIN (dB)	ANTENNA HEIGHT (m)	TABLE ANGLE (Degree)	RAW VALUE (dBuV)	CORRECTION FACTOR (dB/m)
1	#5715.00	61.0 PK	74.0	-13.0	1.36 H	276	56.10	4.90
2	#5715.00	47.1 AV	54.0	-6.9	1.36 H	276	42.20	4.90
3	#5725.00	61.2 PK	78.2	-17.0	1.36 H	276	56.27	4.93
4	*5785.00	116.6 PK			1.36 H	276	111.65	4.95
5	*5785.00	104.2 AV			1.36 H	276	99.25	4.95
6	#5850.00	58.6 PK	78.2	-19.6	1.36 H	276	53.58	5.02
7	#5860.00	61.7 PK	74.0	-12.3	1.36 H	276	56.66	5.04
8	#5860.00	45.4 AV	54.0	-8.6	1.36 H	276	40.36	5.04
9	11570.00	55.0 PK	74.0	-19.0	1.02 H	360	44.32	10.68
10	11570.00	44.8 AV	54.0	-9.2	1.02 H	360	34.12	10.68
11	#17355.00	59.6 PK	74.0	-14.4	1.02 H	267	39.84	19.76
12	#17355.00	50.8 AV	54.0	-3.2	1.02 H	267	31.04	19.76

ANTENNA POLARITY & TEST DISTANCE: VERTICAL AT 3 M

NO.	FREQ. (MHz)	EMISSION LEVEL (dBuV/m)	LIMIT (dBuV/m)	MARGIN (dB)	ANTENNA HEIGHT (m)	TABLE ANGLE (Degree)	RAW VALUE (dBuV)	CORRECTION FACTOR (dB/m)
1	#5715.00	58.2 PK	74.0	-15.8	1.22 V	85	53.30	4.90
2	#5715.00	43.8 AV	54.0	-10.2	1.22 V	85	38.90	4.90
3	#5725.00	54.0 PK	78.2	-24.2	1.22 V	85	49.07	4.93
4	*5785.00	110.2 PK			1.22 V	85	105.25	4.95
5	*5785.00	98.8 AV			1.22 V	85	93.85	4.95
6	#5850.00	51.2 PK	78.2	-27.0	1.22 V	85	46.18	5.02
7	#5860.00	58.6 PK	74.0	-15.4	1.22 V	85	53.56	5.04
8	#5860.00	42.4 AV	54.0	-11.6	1.22 V	85	37.36	5.04
9	11570.00	55.4 PK	74.0	-18.6	1.05 V	217	44.72	10.68
10	11570.00	43.3 AV	54.0	-10.7	1.05 V	217	32.62	10.68
11	#17355.00	60.6 PK	74.0	-13.4	1.17 V	30	40.84	19.76
12	#17355.00	50.2 AV	54.0	-3.8	1.17 V	30	30.44	19.76

REMARKS:

1. Emission Level(dBuV/m) = Raw Value(dBuV) + Correction Factor(dB/m)
2. Correction Factor(dB/m) = Antenna Factor(dB/m) + Cable Factor(dB) – Pre-Amplifier Factor(dB)
3. The other emission levels were very low against the limit.
4. Margin value = Emission Level – Limit value
5. " * ": Fundamental frequency.
6. " # ": The radiated frequency is out of the restricted band.

CHANNEL	TX Channel 165	DETECTOR FUNCTION	Peak (PK)
FREQUENCY RANGE	1GHz ~ 40GHz		Average (AV)

ANTENNA POLARITY & TEST DISTANCE: HORIZONTAL AT 3 M

NO.	FREQ. (MHz)	EMISSION LEVEL (dBuV/m)	LIMIT (dBuV/m)	MARGIN (dB)	ANTENNA HEIGHT (m)	TABLE ANGLE (Degree)	RAW VALUE (dBuV)	CORRECTION FACTOR (dB/m)
1	*5825.00	116.0 PK			1.47 H	275	111.02	4.98
2	*5825.00	104.4 AV			1.47 H	275	99.42	4.98
3	#5850.00	74.4 PK	78.2	-3.8	1.47 H	275	69.38	5.02
4	#5860.00	68.6 PK	74.0	-5.4	1.47 H	275	63.56	5.04
5	#5860.00	50.7 AV	54.0	-3.3	1.47 H	275	45.66	5.04
6	11650.00	55.1 PK	74.0	-18.9	1.02 H	360	44.51	10.59
7	11650.00	44.6 AV	54.0	-9.4	1.02 H	360	34.01	10.59
8	#17475.00	59.9 PK	74.0	-14.1	1.04 H	261	39.95	19.95
9	#17475.00	50.6 AV	54.0	-3.4	1.04 H	261	30.65	19.95

ANTENNA POLARITY & TEST DISTANCE: VERTICAL AT 3 M

NO.	FREQ. (MHz)	EMISSION LEVEL (dBuV/m)	LIMIT (dBuV/m)	MARGIN (dB)	ANTENNA HEIGHT (m)	TABLE ANGLE (Degree)	RAW VALUE (dBuV)	CORRECTION FACTOR (dB/m)
1	*5825.00	110.5 PK			1.17 V	81	105.52	4.98
2	*5825.00	99.0 AV			1.17 V	81	94.02	4.98
3	#5850.00	67.2 PK	78.2	-11.0	1.17 V	81	62.18	5.02
4	#5860.00	65.4 PK	74.0	-8.6	1.17 V	81	60.36	5.04
5	#5860.00	46.8 AV	54.0	-7.2	1.17 V	81	41.76	5.04
6	11650.00	54.8 PK	74.0	-19.2	1.05 V	211	44.21	10.59
7	11650.00	42.8 AV	54.0	-11.2	1.05 V	211	32.21	10.59
8	#17475.00	60.7 PK	74.0	-13.3	1.22 V	46	40.75	19.95
9	#17475.00	50.4 AV	54.0	-3.6	1.22 V	46	30.45	19.95

REMARKS:

1. Emission Level(dBuV/m) = Raw Value(dBuV) + Correction Factor(dB/m)
2. Correction Factor(dB/m) = Antenna Factor(dB/m) + Cable Factor(dB) – Pre-Amplifier Factor(dB)
3. The other emission levels were very low against the limit.
4. Margin value = Emission Level – Limit value
5. " * ": Fundamental frequency.
6. " # ": The radiated frequency is out of the restricted band.

802.11n (HT20)

CHANNEL	TX Channel 149	DETECTOR FUNCTION	Peak (PK)
FREQUENCY RANGE	1GHz ~ 40GHz		Average (AV)

ANTENNA POLARITY & TEST DISTANCE: HORIZONTAL AT 3 M

NO.	FREQ. (MHz)	EMISSION LEVEL (dBuV/m)	LIMIT (dBuV/m)	MARGIN (dB)	ANTENNA HEIGHT (m)	TABLE ANGLE (Degree)	RAW VALUE (dBuV)	CORRECTION FACTOR (dB/m)
1	#5715.00	65.5 PK	74.0	-8.5	1.36 H	282	60.60	4.90
2	#5715.00	48.6 AV	54.0	-5.4	1.36 H	282	43.70	4.90
3	#5725.00	76.9 PK	78.2	-1.3	1.36 H	282	71.97	4.93
4	*5745.00	114.1 PK			1.37 H	282	109.18	4.92
5	*5745.00	100.8 AV			1.37 H	282	95.88	4.92
6	11490.00	53.8 PK	74.0	-20.2	1.03 H	360	43.15	10.65
7	11490.00	42.7 AV	54.0	-11.3	1.03 H	360	32.05	10.65
8	#17235.00	59.5 PK	74.0	-14.5	1.11 H	274	40.05	19.45
9	#17235.00	50.2 AV	54.0	-3.8	1.11 H	274	30.75	19.45

ANTENNA POLARITY & TEST DISTANCE: VERTICAL AT 3 M

NO.	FREQ. (MHz)	EMISSION LEVEL (dBuV/m)	LIMIT (dBuV/m)	MARGIN (dB)	ANTENNA HEIGHT (m)	TABLE ANGLE (Degree)	RAW VALUE (dBuV)	CORRECTION FACTOR (dB/m)
1	#5715.00	62.2 PK	74.0	-11.8	1.07 V	152	57.30	4.90
2	#5715.00	46.2 AV	54.0	-7.8	1.07 V	152	41.30	4.90
3	#5725.00	71.2 PK	78.2	-7.0	1.07 V	152	66.27	4.93
4	*5745.00	106.7 PK			1.07 V	152	101.78	4.92
5	*5745.00	95.3 AV			1.07 V	152	90.38	4.92
6	11490.00	55.4 PK	74.0	-18.6	1.10 V	200	44.75	10.65
7	11490.00	43.6 AV	54.0	-10.4	1.10 V	200	32.95	10.65
8	#17235.00	60.6 PK	74.0	-13.4	1.15 V	70	41.15	19.45
9	#17235.00	50.2 AV	54.0	-3.8	1.15 V	70	30.75	19.45

REMARKS:

- Emission Level(dBuV/m) = Raw Value(dBuV) + Correction Factor(dB/m)
- Correction Factor(dB/m) = Antenna Factor(dB/m) + Cable Factor(dB) – Pre-Amplifier Factor(dB)
- The other emission levels were very low against the limit.
- Margin value = Emission Level – Limit value
- " * ": Fundamental frequency.
- " # ": The radiated frequency is out of the restricted band.

CHANNEL	TX Channel 157	DETECTOR FUNCTION	Peak (PK)
FREQUENCY RANGE	1GHz ~ 40GHz		Average (AV)

ANTENNA POLARITY & TEST DISTANCE: HORIZONTAL AT 3 M

NO.	FREQ. (MHz)	EMISSION LEVEL (dBuV/m)	LIMIT (dBuV/m)	MARGIN (dB)	ANTENNA HEIGHT (m)	TABLE ANGLE (Degree)	RAW VALUE (dBuV)	CORRECTION FACTOR (dB/m)
1	#5715.00	61.3 PK	74.0	-12.7	1.40 H	280	56.40	4.90
2	#5715.00	47.3 AV	54.0	-6.7	1.40 H	280	42.40	4.90
3	#5725.00	60.9 PK	78.2	-17.3	1.40 H	280	55.97	4.93
4	*5785.00	116.8 PK			1.40 H	280	111.85	4.95
5	*5785.00	104.6 AV			1.40 H	280	99.65	4.95
6	#5850.00	58.7 PK	78.2	-19.5	1.40 H	280	53.68	5.02
7	#5860.00	61.3 PK	74.0	-12.7	1.40 H	280	56.26	5.04
8	#5860.00	45.2 AV	54.0	-8.8	1.40 H	280	40.16	5.04
9	11570.00	54.6 PK	74.0	-19.4	1.00 H	360	43.92	10.68
10	11570.00	44.3 AV	54.0	-9.7	1.00 H	360	33.62	10.68
11	#17355.00	61.4 PK	74.0	-12.6	1.00 H	252	41.64	19.76
12	#17355.00	50.8 AV	54.0	-3.2	1.00 H	252	31.04	19.76

ANTENNA POLARITY & TEST DISTANCE: VERTICAL AT 3 M

NO.	FREQ. (MHz)	EMISSION LEVEL (dBuV/m)	LIMIT (dBuV/m)	MARGIN (dB)	ANTENNA HEIGHT (m)	TABLE ANGLE (Degree)	RAW VALUE (dBuV)	CORRECTION FACTOR (dB/m)
1	#5715.00	58.7 PK	74.0	-15.3	1.20 V	96	53.80	4.90
2	#5715.00	44.2 AV	54.0	-9.8	1.20 V	96	39.30	4.90
3	#5725.00	54.2 PK	78.2	-24.0	1.20 V	96	49.27	4.93
4	*5785.00	110.0 PK			1.20 V	96	105.05	4.95
5	*5785.00	98.5 AV			1.20 V	96	93.55	4.95
6	#5850.00	51.2 PK	78.2	-27.0	1.20 V	96	46.18	5.02
7	#5860.00	58.1 PK	74.0	-15.9	1.20 V	96	53.06	5.04
8	#5860.00	41.3 AV	54.0	-12.7	1.20 V	96	36.26	5.04
9	11570.00	56.1 PK	74.0	-17.9	1.00 V	217	45.42	10.68
10	11570.00	43.9 AV	54.0	-10.1	1.00 V	217	33.22	10.68
11	#17355.00	60.9 PK	74.0	-13.1	1.18 V	19	41.14	19.76
12	#17355.00	50.4 AV	54.0	-3.6	1.18 V	19	30.64	19.76

REMARKS:

1. Emission Level(dBuV/m) = Raw Value(dBuV) + Correction Factor(dB/m)
2. Correction Factor(dB/m) = Antenna Factor(dB/m) + Cable Factor(dB) – Pre-Amplifier Factor(dB)
3. The other emission levels were very low against the limit.
4. Margin value = Emission Level – Limit value
5. " * ": Fundamental frequency.
6. " # ": The radiated frequency is out of the restricted band.

CHANNEL	TX Channel 165	DETECTOR FUNCTION	Peak (PK)
FREQUENCY RANGE	1GHz ~ 40GHz		Average (AV)

ANTENNA POLARITY & TEST DISTANCE: HORIZONTAL AT 3 M

NO.	FREQ. (MHz)	EMISSION LEVEL (dBuV/m)	LIMIT (dBuV/m)	MARGIN (dB)	ANTENNA HEIGHT (m)	TABLE ANGLE (Degree)	RAW VALUE (dBuV)	CORRECTION FACTOR (dB/m)
1	*5825.00	117.3 PK			1.36 H	282	112.32	4.98
2	*5825.00	104.0 AV			1.36 H	282	99.02	4.98
3	#5850.00	73.5 PK	78.2	-4.7	1.36 H	282	68.48	5.02
4	#5860.00	69.6 PK	74.0	-4.4	1.36 H	282	64.56	5.04
5	#5860.00	50.4 AV	54.0	-3.6	1.36 H	282	45.36	5.04
6	11650.00	54.1 PK	74.0	-19.9	1.06 H	360	43.51	10.59
7	11650.00	44.0 AV	54.0	-10.0	1.06 H	360	33.41	10.59
8	#17475.00	61.1 PK	74.0	-12.9	1.02 H	246	41.15	19.95
9	#17475.00	50.9 AV	54.0	-3.1	1.02 H	246	30.95	19.95

ANTENNA POLARITY & TEST DISTANCE: VERTICAL AT 3 M

NO.	FREQ. (MHz)	EMISSION LEVEL (dBuV/m)	LIMIT (dBuV/m)	MARGIN (dB)	ANTENNA HEIGHT (m)	TABLE ANGLE (Degree)	RAW VALUE (dBuV)	CORRECTION FACTOR (dB/m)
1	*5825.00	110.0 PK			1.24 V	96	105.02	4.98
2	*5825.00	98.8 AV			1.24 V	96	93.82	4.98
3	#5850.00	67.6 PK	78.2	-10.6	1.24 V	96	62.58	5.02
4	#5860.00	65.4 PK	74.0	-8.6	1.24 V	96	60.36	5.04
5	#5860.00	46.2 AV	54.0	-7.8	1.24 V	96	41.16	5.04
6	11650.00	56.4 PK	74.0	-17.6	1.00 V	202	45.81	10.59
7	11650.00	44.3 AV	54.0	-9.7	1.00 V	202	33.71	10.59
8	#17475.00	60.7 PK	74.0	-13.3	1.15 V	13	40.75	19.95
9	#17475.00	50.4 AV	54.0	-3.6	1.15 V	13	30.45	19.95

REMARKS:

1. Emission Level(dBuV/m) = Raw Value(dBuV) + Correction Factor(dB/m)
2. Correction Factor(dB/m) = Antenna Factor(dB/m) + Cable Factor(dB) – Pre-Amplifier Factor(dB)
3. The other emission levels were very low against the limit.
4. Margin value = Emission Level – Limit value
5. " * ": Fundamental frequency.
6. " # ": The radiated frequency is out of the restricted band.

Below 1GHz Data
802.11a

CHANNEL	TX Channel 149	DETECTOR FUNCTION	Quasi-Peak (QP)
FREQUENCY RANGE	Below 1GHz		

ANTENNA POLARITY & TEST DISTANCE: HORIZONTAL AT 3 M

NO.	FREQ. (MHz)	EMISSION LEVEL (dBuV/m)	LIMIT (dBuV/m)	MARGIN (dB)	ANTENNA HEIGHT (m)	TABLE ANGLE (Degree)	RAW VALUE (dBuV)	CORRECTION FACTOR (dB/m)
1	435.34	29.3 QP	46.0	-16.7	1.56 H	213	37.78	-8.52
2	485.84	27.5 QP	46.0	-18.5	1.49 H	183	35.14	-7.65
3	588.80	29.8 QP	46.0	-16.2	1.45 H	319	35.13	-5.31
4	613.03	28.4 QP	46.0	-17.6	1.49 H	206	32.88	-4.46
5	691.33	29.9 QP	46.0	-16.1	1.43 H	228	33.57	-3.64
6	717.09	27.7 QP	46.0	-18.3	1.10 H	139	31.04	-3.31

ANTENNA POLARITY & TEST DISTANCE: VERTICAL AT 3 M

NO.	FREQ. (MHz)	EMISSION LEVEL (dBuV/m)	LIMIT (dBuV/m)	MARGIN (dB)	ANTENNA HEIGHT (m)	TABLE ANGLE (Degree)	RAW VALUE (dBuV)	CORRECTION FACTOR (dB/m)
1	435.12	26.3 QP	46.0	-19.7	1.43 V	220	34.87	-8.53
2	485.94	29.2 QP	46.0	-16.8	1.41 V	203	36.80	-7.64
3	589.44	28.6 QP	46.0	-17.4	1.13 V	195	33.88	-5.29
4	614.10	28.3 QP	46.0	-17.7	1.73 V	194	32.72	-4.46
5	691.33	27.7 QP	46.0	-18.3	1.49 V	223	31.32	-3.64
6	940.58	28.9 QP	46.0	-17.1	1.53 V	164	28.06	0.85

REMARKS:

1. Emission Level(dBuV/m) = Raw Value(dBuV) + Correction Factor(dB/m)
2. Correction Factor(dB/m) = Antenna Factor(dB/m) + Cable Factor(dB) – Pre-Amplifier Factor(dB)
3. The other emission levels were very low against the limit.
4. Margin value = Emission Level – Limit value

CHANNEL	TX Channel 157	DETECTOR FUNCTION	Quasi-Peak (QP)
FREQUENCY RANGE	Below 1GHz		

ANTENNA POLARITY & TEST DISTANCE: HORIZONTAL AT 3 M

NO.	FREQ. (MHz)	EMISSION LEVEL (dBuV/m)	LIMIT (dBuV/m)	MARGIN (dB)	ANTENNA HEIGHT (m)	TABLE ANGLE (Degree)	RAW VALUE (dBuV)	CORRECTION FACTOR (dB/m)
1	435.34	29.3 QP	46.0	-16.7	1.66 H	194	37.78	-8.52
2	485.84	27.5 QP	46.0	-18.6	1.46 H	187	35.10	-7.65
3	588.80	29.8 QP	46.0	-16.2	1.59 H	225	35.14	-5.31
4	613.03	28.3 QP	46.0	-17.7	1.42 H	128	32.74	-4.46
5	691.33	29.8 QP	46.0	-16.2	1.00 H	206	33.41	-3.64
6	717.09	28.1 QP	46.0	-17.9	1.43 H	225	31.44	-3.31

ANTENNA POLARITY & TEST DISTANCE: VERTICAL AT 3 M

NO.	FREQ. (MHz)	EMISSION LEVEL (dBuV/m)	LIMIT (dBuV/m)	MARGIN (dB)	ANTENNA HEIGHT (m)	TABLE ANGLE (Degree)	RAW VALUE (dBuV)	CORRECTION FACTOR (dB/m)
1	435.12	26.5 QP	46.0	-19.5	1.42 V	192	35.06	-8.53
2	485.94	29.3 QP	46.0	-16.7	1.38 V	226	36.90	-7.64
3	589.44	28.6 QP	46.0	-17.4	1.16 V	206	33.93	-5.29
4	614.10	28.3 QP	46.0	-17.7	1.68 V	205	32.76	-4.46
5	691.33	27.7 QP	46.0	-18.3	1.59 V	208	31.35	-3.64
6	940.58	28.9 QP	46.0	-17.2	1.46 V	133	28.00	0.85

REMARKS:

1. Emission Level(dBuV/m) = Raw Value(dBuV) + Correction Factor(dB/m)
2. Correction Factor(dB/m) = Antenna Factor(dB/m) + Cable Factor(dB) – Pre-Amplifier Factor(dB)
3. The other emission levels were very low against the limit.
4. Margin value = Emission Level – Limit value

CHANNEL	TX Channel 165	DETECTOR FUNCTION	Quasi-Peak (QP)
FREQUENCY RANGE	Below 1GHz		

ANTENNA POLARITY & TEST DISTANCE: HORIZONTAL AT 3 M

NO.	FREQ. (MHz)	EMISSION LEVEL (dBuV/m)	LIMIT (dBuV/m)	MARGIN (dB)	ANTENNA HEIGHT (m)	TABLE ANGLE (Degree)	RAW VALUE (dBuV)	CORRECTION FACTOR (dB/m)
1	435.34	29.5 QP	46.0	-16.5	2.03 H	179	38.01	-8.52
2	485.84	27.6 QP	46.0	-18.4	1.56 H	113	35.29	-7.65
3	588.80	30.0 QP	46.0	-16.0	1.68 H	105	35.27	-5.31
4	613.03	28.5 QP	46.0	-17.5	1.62 H	243	32.97	-4.46
5	691.33	29.0 QP	46.0	-17.0	1.05 H	195	32.66	-3.64
6	717.09	28.3 QP	46.0	-17.7	1.43 H	109	31.60	-3.31

ANTENNA POLARITY & TEST DISTANCE: VERTICAL AT 3 M

NO.	FREQ. (MHz)	EMISSION LEVEL (dBuV/m)	LIMIT (dBuV/m)	MARGIN (dB)	ANTENNA HEIGHT (m)	TABLE ANGLE (Degree)	RAW VALUE (dBuV)	CORRECTION FACTOR (dB/m)
1	435.12	26.5 QP	46.0	-19.5	1.38 V	221	35.02	-8.53
2	485.94	29.4 QP	46.0	-16.6	1.00 V	305	37.02	-7.64
3	589.44	28.4 QP	46.0	-17.6	1.47 V	311	33.70	-5.29
4	614.10	28.4 QP	46.0	-17.6	2.00 V	327	32.82	-4.46
5	691.33	27.2 QP	46.0	-18.8	1.00 V	78	30.85	-3.64
6	940.58	28.8 QP	46.0	-17.2	1.55 V	243	27.91	0.85

REMARKS:

1. Emission Level(dBuV/m) = Raw Value(dBuV) + Correction Factor(dB/m)
2. Correction Factor(dB/m) = Antenna Factor(dB/m) + Cable Factor(dB) – Pre-Amplifier Factor(dB)
3. The other emission levels were very low against the limit.
4. Margin value = Emission Level – Limit value

802.11n (HT20)

CHANNEL	TX Channel 149	DETECTOR FUNCTION	Quasi-Peak (QP)
FREQUENCY RANGE	Below 1GHz		

ANTENNA POLARITY & TEST DISTANCE: HORIZONTAL AT 3 M

NO.	FREQ. (MHz)	EMISSION LEVEL (dBuV/m)	LIMIT (dBuV/m)	MARGIN (dB)	ANTENNA HEIGHT (m)	TABLE ANGLE (Degree)	RAW VALUE (dBuV)	CORRECTION FACTOR (dB/m)
1	435.34	29.4 QP	46.0	-16.7	1.55 H	243	37.87	-8.52
2	485.84	27.5 QP	46.0	-18.5	1.49 H	225	35.14	-7.65
3	588.80	29.7 QP	46.0	-16.3	1.55 H	287	34.98	-5.31
4	613.03	28.0 QP	46.0	-18.0	1.47 H	249	32.49	-4.46
5	691.33	29.9 QP	46.0	-16.1	1.05 H	243	33.55	-3.64
6	717.09	27.7 QP	46.0	-18.3	1.03 H	224	31.04	-3.31

ANTENNA POLARITY & TEST DISTANCE: VERTICAL AT 3 M

NO.	FREQ. (MHz)	EMISSION LEVEL (dBuV/m)	LIMIT (dBuV/m)	MARGIN (dB)	ANTENNA HEIGHT (m)	TABLE ANGLE (Degree)	RAW VALUE (dBuV)	CORRECTION FACTOR (dB/m)
1	435.12	26.6 QP	46.0	-19.4	1.02 V	142	35.16	-8.53
2	485.94	29.5 QP	46.0	-16.5	1.18 V	254	37.10	-7.64
3	589.44	28.7 QP	46.0	-17.3	1.83 V	227	34.02	-5.29
4	614.10	28.7 QP	46.0	-17.3	1.03 V	255	33.18	-4.46
5	691.33	27.4 QP	46.0	-18.6	1.13 V	249	31.03	-3.64
6	940.58	28.9 QP	46.0	-17.2	1.63 V	113	28.00	0.85

REMARKS:

1. Emission Level(dBuV/m) = Raw Value(dBuV) + Correction Factor(dB/m)
2. Correction Factor(dB/m) = Antenna Factor(dB/m) + Cable Factor(dB) – Pre-Amplifier Factor(dB)
3. The other emission levels were very low against the limit.
4. Margin value = Emission Level – Limit value

CHANNEL	TX Channel 157	DETECTOR FUNCTION	Quasi-Peak (QP)
FREQUENCY RANGE	Below 1GHz		

ANTENNA POLARITY & TEST DISTANCE: HORIZONTAL AT 3 M

NO.	FREQ. (MHz)	EMISSION LEVEL (dBuV/m)	LIMIT (dBuV/m)	MARGIN (dB)	ANTENNA HEIGHT (m)	TABLE ANGLE (Degree)	RAW VALUE (dBuV)	CORRECTION FACTOR (dB/m)
1	435.34	29.2 QP	46.0	-16.8	1.43 H	205	37.71	-8.52
2	485.84	27.6 QP	46.0	-18.5	1.28 H	143	35.20	-7.65
3	588.80	29.8 QP	46.0	-16.2	1.68 H	102	35.09	-5.31
4	613.03	28.5 QP	46.0	-17.5	1.62 H	229	33.00	-4.46
5	691.33	29.8 QP	46.0	-16.2	2.26 H	172	33.48	-3.64
6	717.09	27.8 QP	46.0	-18.2	1.43 H	205	31.10	-3.31

ANTENNA POLARITY & TEST DISTANCE: VERTICAL AT 3 M

NO.	FREQ. (MHz)	EMISSION LEVEL (dBuV/m)	LIMIT (dBuV/m)	MARGIN (dB)	ANTENNA HEIGHT (m)	TABLE ANGLE (Degree)	RAW VALUE (dBuV)	CORRECTION FACTOR (dB/m)
1	435.12	26.4 QP	46.0	-19.6	1.72 V	203	34.96	-8.53
2	485.94	29.4 QP	46.0	-16.6	1.36 V	226	37.00	-7.64
3	589.45	28.5 QP	46.0	-17.5	1.12 V	206	33.78	-5.29
4	614.10	28.7 QP	46.0	-17.4	1.00 V	143	33.11	-4.46
5	691.33	27.5 QP	46.0	-18.5	1.29 V	305	31.13	-3.64
6	940.58	28.7 QP	46.0	-17.3	1.42 V	102	27.82	0.85

REMARKS:

1. Emission Level(dBuV/m) = Raw Value(dBuV) + Correction Factor(dB/m)
2. Correction Factor(dB/m) = Antenna Factor(dB/m) + Cable Factor(dB) – Pre-Amplifier Factor(dB)
3. The other emission levels were very low against the limit.
4. Margin value = Emission Level – Limit value

CHANNEL	TX Channel 165	DETECTOR FUNCTION	Quasi-Peak (QP)
FREQUENCY RANGE	Below 1GHz		

ANTENNA POLARITY & TEST DISTANCE: HORIZONTAL AT 3 M

NO.	FREQ. (MHz)	EMISSION LEVEL (dBuV/m)	LIMIT (dBuV/m)	MARGIN (dB)	ANTENNA HEIGHT (m)	TABLE ANGLE (Degree)	RAW VALUE (dBuV)	CORRECTION FACTOR (dB/m)
1	435.34	29.5 QP	46.0	-16.5	1.43 H	187	37.98	-8.52
2	485.84	28.5 QP	46.0	-17.5	1.23 H	267	36.18	-7.65
3	588.80	29.8 QP	46.0	-16.3	1.48 H	193	35.06	-5.31
4	613.03	28.2 QP	46.0	-17.8	1.31 H	197	32.64	-4.46
5	691.33	29.7 QP	46.0	-16.3	1.19 H	98	33.37	-3.64
6	717.09	27.7 QP	46.0	-18.3	1.00 H	167	31.03	-3.31

ANTENNA POLARITY & TEST DISTANCE: VERTICAL AT 3 M

NO.	FREQ. (MHz)	EMISSION LEVEL (dBuV/m)	LIMIT (dBuV/m)	MARGIN (dB)	ANTENNA HEIGHT (m)	TABLE ANGLE (Degree)	RAW VALUE (dBuV)	CORRECTION FACTOR (dB/m)
1	435.12	26.4 QP	46.0	-19.6	1.43 V	114	34.91	-8.53
2	485.94	29.5 QP	46.0	-16.5	1.42 V	203	37.13	-7.64
3	589.44	28.6 QP	46.0	-17.5	1.09 V	219	33.84	-5.29
4	614.10	28.7 QP	46.0	-17.3	1.47 V	226	33.19	-4.46
5	691.33	27.5 QP	46.0	-18.5	1.08 V	249	31.17	-3.64
6	940.58	28.6 QP	46.0	-17.4	1.38 V	205	27.78	0.85

REMARKS:

1. Emission Level(dBuV/m) = Raw Value(dBuV) + Correction Factor(dB/m)
2. Correction Factor(dB/m) = Antenna Factor(dB/m) + Cable Factor(dB) – Pre-Amplifier Factor(dB)
3. The other emission levels were very low against the limit.
4. Margin value = Emission Level – Limit value

4.2 Transmit Power Measurement

4.2.1 Limits of Transmit Power Measurement

Operation Band	EUT Category		Limit
U-NII-1		Outdoor Access Point	1 Watt (30 dBm) (Max. e.i.r.p \leq 125mW(21 dBm) at any elevation angle above 30 degrees as measured from the horizon)
		Fixed point-to-point Access Point	1 Watt (30 dBm)
		Indoor Access Point	1 Watt (30 dBm)
		Mobile and Portable client device	250mW (24 dBm)
U-NII-2A			250mW (24 dBm) or 11 dBm+10 log B*
U-NII-2C			250mW (24 dBm) or 11 dBm+10 log B*
U-NII-3	√		1 Watt (30 dBm)

*B is the 26 dB emission bandwidth in megahertz

4.2.2 Test Setup

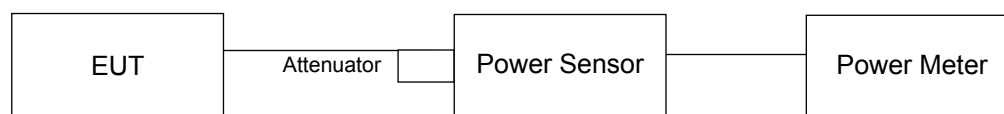

4.2.3 Test Instruments

Refer to section 4.1.2 to get information of above instrument.

4.2.4 Test Procedures

Method PM is used to perform output power measurement, trigger and gating function of wide band power meter is enabled to measure max output power of TX on burst. Duty factor is not added to measured value.

4.2.5 Deviation from Test Standard

No deviation.

4.2.6 EUT Operating Conditions

The software provided by client to enable the EUT under transmission condition continuously at lowest, middle and highest channel frequencies individually.

4.2.7 Test Result

802.11a

Chan.	Chan. Freq. (MHz)	Average Power (mW)	Average Power (dBm)	Limit (dBm)	Pass / Fail
149	5745	27.416	14.38	30	Pass
157	5785	42.658	16.30	30	Pass
165	5825	42.855	16.32	30	Pass

802.11n (HT20)

Chan.	Chan. Freq. (MHz)	Average Power (mW)	Average Power (dBm)	Limit (dBm)	Pass / Fail
149	5745	25.41	14.05	30	Pass
157	5785	41.115	16.14	30	Pass
165	5825	40.738	16.10	30	Pass

※Add test for each data rate output power (require by manufacturer):

802.11a

CHANNEL	FREQUENCY (MHz)	AVERAGE POWER (dBm)							
		Data rate							
		6Mbps	9Mbps	12Mbps	18Mbps	24Mbps	36Mbps	48Mbps	54Mbps
149	5745	14.38	14.31	14.30	14.22	14.29	14.25	14.27	14.32
157	5785	16.30	16.26	16.12	16.16	16.16	16.22	16.27	16.26
165	5825	16.32	16.20	16.29	16.15	16.19	16.16	16.22	16.18

802.11n (HT20)

CHANNEL	FREQUENCY (MHz)	AVERAGE POWER (dBm)							
		Data rate							
		MCS0	MCS1	MCS2	MCS3	MCS4	MCS5	MCS6	MCS7
149	5745	14.05	13.98	13.87	14.00	14.03	13.98	14.03	13.93
157	5785	16.14	16.13	16.05	16.01	16.11	16.07	16.03	16.12
165	5825	16.10	16.01	16.02	16.06	16.02	15.96	16.06	15.97

4.3 Peak Power Spectral Density Measurement

4.3.1 Limits of Peak Power Spectral Density Measurement

Operation Band	EUT Category		Limit
U-NII-1		Outdoor Access Point	17dBm/ MHz
		Fixed point-to-point Access Point	
		Indoor Access Point	
		Mobile and Portable client device	11dBm/ MHz
U-NII-2A			11dBm/ MHz
U-NII-2C			11dBm/ MHz
U-NII-3		√	30dBm/ 500kHz

4.3.2 Test Setup

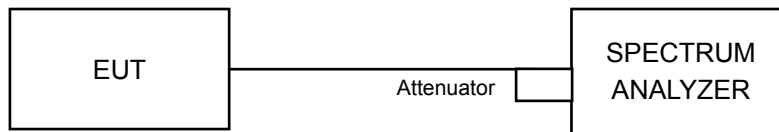

4.3.3 Test Instruments

Refer to section 4.1.2 to get information of above instrument.

4.3.4 Test Procedures

For U-NII-3 band:

1. Set span to encompass the entire emission bandwidth (EBW) of the signal.
2. Set RBW = 300 kHz, Set VBW ≥ 1 MHz, Detector = RMS
3. Use the peak marker function to determine the maximum power level in any 300 kHz band segment within the fundamental EBW.
4. Scale the observed power level to an equivalent value in 500 kHz by adjusting (reducing) the measured power by a bandwidth correction factor (BWCF) where $BWCF = 10\log(500\text{ kHz}/300\text{kHz})$
5. Sweep time = auto, trigger set to "free run".
6. Trace average at least 100 traces in power averaging mode.
7. Record the max value

4.3.5 Deviation from Test Standard

No deviation.

4.3.6 EUT Operating Conditions

Same as Item 4.2.6

4.3.7 Test Results

For U-NII-3:

802.11a

CHANNEL	FREQUENCY (MHz)	PSD W/O DUTY FACTOR		DUTY FACTOR (dB)	TOTAL PSD WITH DUTY FACTOR (dBm/500kHz)	LIMIT (dBm/500kHz)	PASS /FAIL
		(dBm/300kHz)	(dBm/500kHz)				
149	5745	-8.16	-5.94	0.33	-5.61	30	PASS
157	5785	-6.41	-4.19	0.33	-3.86	30	PASS
165	5825	-6.03	-3.81	0.33	-3.48	30	PASS

802.11n (HT20)

CHANNEL	FREQUENCY (MHz)	PSD W/O DUTY FACTOR		DUTY FACTOR (dB)	TOTAL PSD WITH DUTY FACTOR (dBm/500kHz)	LIMIT (dBm/500kHz)	PASS /FAIL
		(dBm/300kHz)	(dBm/500kHz)				
149	5745	-9.06	-6.84	0.41	-6.43	30	PASS
157	5785	-6.64	-4.42	0.41	-4.01	30	PASS
165	5825	-6.69	-4.47	0.41	-4.06	30	PASS

Spectrum Plot of Worst Value

802.11a / CH165

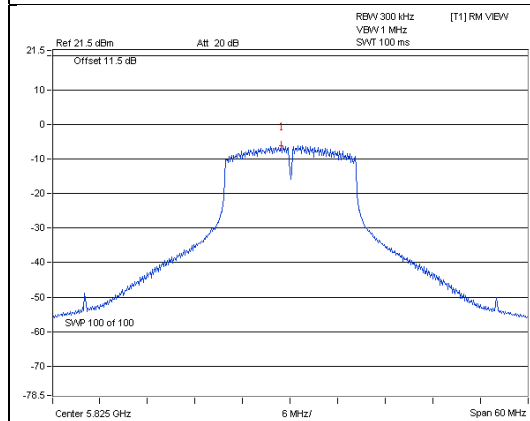

802.11n (HT20) / CH157

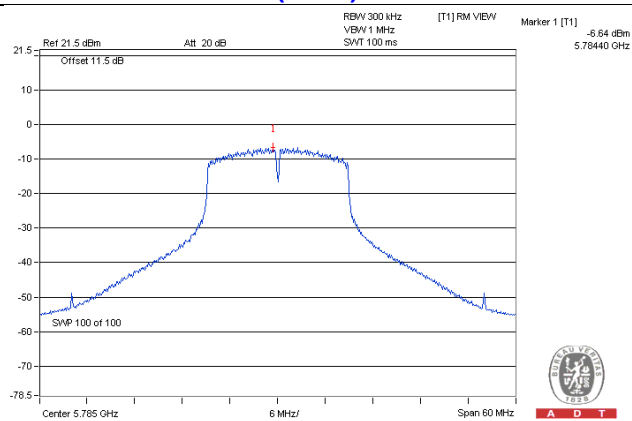

4.4 Frequency Stability Measurement

4.4.1 Limits of Frequency Stability Measurement

The frequency of the carrier signal shall be maintained within band of operation

4.4.2 Test Setup

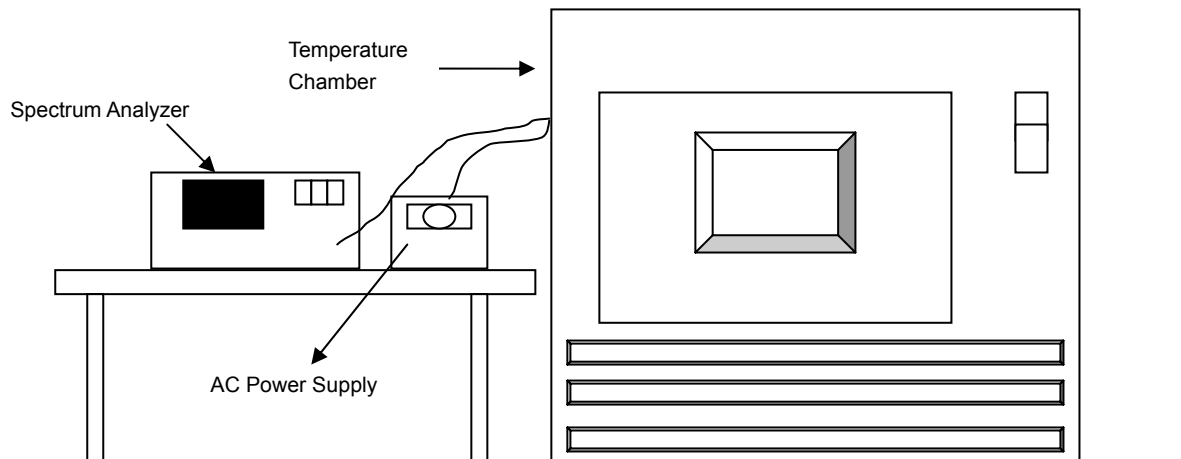

4.4.3 Test Instruments

Refer to section 4.1.2 to get information of above instrument.

4.4.4 Test Procedures

- The EUT was placed inside the environmental test chamber and powered by nominal AC voltage.
- Turn the EUT on and couple its output to a spectrum analyzer.
- Turn the EUT off and set the chamber to the highest temperature specified.
- Allow sufficient time (approximately 30 min) for the temperature of the chamber to stabilize, turn the EUT on and measure the operating frequency after 2, 5, and 10 minutes.
- Repeat step 2 and 3 with the temperature chamber set to the lowest temperature.
- The test chamber was allowed to stabilize at +20 degree C for a minimum of 30 minutes. The supply voltage was then adjusted on the EUT from 85% to 115% and the frequency record.

4.4.5 Deviation from Test Standard

No deviation.

4.4.6 EUT Operating Conditions

Set the EUT transmit at un-modulation mode to test frequency stability.

4.4.7 Test Results

Frequency Stability Versus Temp.									
Operating Frequency: 5825MHz									
Temp. (°C)	Power Supply (Vac)	0 Minute		2 Minute		5 Minute		10 Minute	
		Measured Frequency (MHz)	Frequency Drift (%)	Measured Frequency (MHz)	Frequency Drift (%)	Measured Frequency (MHz)	Frequency Drift (%)	Measured Frequency (MHz)	Frequency Drift (%)
50	120	5825.0268	0.00046	5825.0292	0.00050	5825.0263	0.00045	5825.0271	0.00047
40	120	5824.9881	-0.00020	5824.9879	-0.00021	5824.9908	-0.00016	5824.9877	-0.00021
30	120	5824.9959	-0.00007	5824.997	-0.00005	5824.9954	-0.00008	5824.9971	-0.00005
20	120	5824.987	-0.00022	5824.9844	-0.00027	5824.9854	-0.00025	5824.9836	-0.00028
10	120	5824.9939	-0.00010	5824.9971	-0.00005	5824.9947	-0.00009	5824.9975	-0.00004
0	120	5825.0122	0.00021	5825.0069	0.00012	5825.0091	0.00016	5825.0096	0.00016
-10	120	5824.971	-0.00050	5824.9707	-0.00050	5824.9748	-0.00043	5824.9728	-0.00047
-20	120	5825.0209	0.00036	5825.0215	0.00037	5825.0204	0.00035	5825.02	0.00034
-30	120	5824.9782	-0.00037	5824.9784	-0.00037	5824.979	-0.00036	5824.9797	-0.00035

Frequency Stability Versus Temp.									
Operating Frequency: 5825MHz									
Temp. (°C)	Power Supply (Vac)	0 Minute		2 Minute		5 Minute		10 Minute	
		Measured Frequency (MHz)	Frequency Drift (%)	Measured Frequency (MHz)	Frequency Drift (%)	Measured Frequency (MHz)	Frequency Drift (%)	Measured Frequency (MHz)	Frequency Drift (%)
20	138	5824.9867	-0.00023	5824.985	-0.00026	5824.9861	-0.00024	5824.9839	-0.00028
	120	5824.987	-0.00022	5824.9844	-0.00027	5824.9854	-0.00025	5824.9836	-0.00028
	102	5824.987	-0.00022	5824.9835	-0.00028	5824.9845	-0.00027	5824.9845	-0.00027

4.5 6dB Bandwidth Measurement

4.5.1 Limits of 6dB Bandwidth Measurement

The minimum of 6dB Bandwidth Measurement is 0.5MHz.

4.5.2 Test Setup

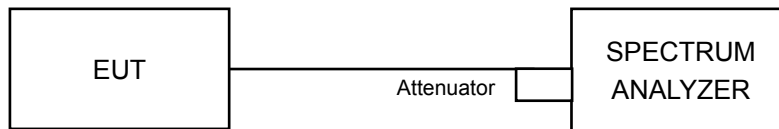

4.5.3 Test Instruments

Refer to section 4.1.2 to get information of above instrument.

4.5.4 Test Procedures

MEASUREMENT PROCEDURE REF

- a. Set resolution bandwidth (RBW) = 100kHz
- b. Set the video bandwidth (VBW) $\geq 3 \times$ RBW, Detector = Peak.
- c. Trace mode = max hold.
- d. Sweep = auto couple.
- e. Measure the maximum width of the emission that is constrained by the frequencies associated with the two amplitude points (upper and lower) that are attenuated by 6 dB relative to the maximum level measured in the fundamental emission

4.5.5 Deviation from Test Standard

No deviation.

4.5.6 EUT Operating Conditions

The software provided by client to enable the EUT under transmission condition continuously at lowest, middle and highest channel frequencies individually.

4.5.7 Test Results

802.11a

Channel	Frequency (MHz)	6dB Bandwidth (MHz)	Minimum Limit (MHz)	Pass / Fail
149	5745	15.53	0.5	Pass
157	5785	15.36	0.5	Pass
165	5825	15.42	0.5	Pass

802.11n (HT20)

Channel	Frequency (MHz)	6dB Bandwidth (MHz)	Minimum Limit (MHz)	Pass / Fail
149	5745	16.15	0.5	Pass
157	5785	15.73	0.5	Pass
165	5825	15.27	0.5	Pass

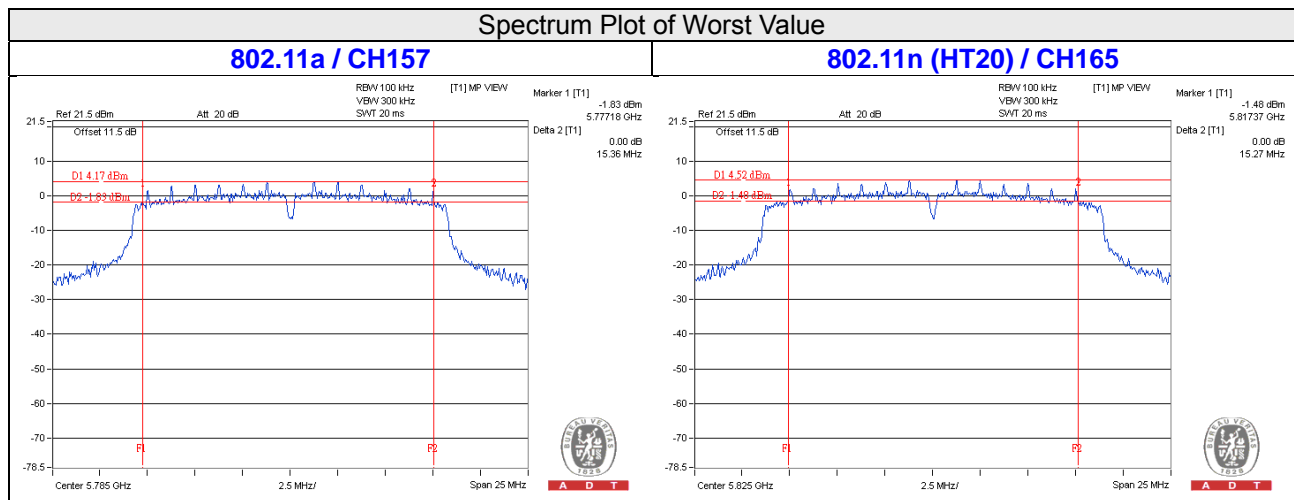

5 Pictures of Test Arrangements

Please refer to the attached file (Test Setup Photo).



Appendix – Information on the Testing Laboratories

We, Bureau Veritas Consumer Products Services (H.K.) Ltd., Taoyuan Branch, were founded in 1988 to provide our best service in EMC, Radio, Telecom and Safety consultation. Our laboratories are accredited and approved according to ISO/IEC 17025.

If you have any comments, please feel free to contact us at the following:

Linko EMC/RF Lab

Tel: 886-2-26052180

Fax: 886-2-26051924

Hsin Chu EMC/RF Lab/Telecom Lab

Tel: 886-3-5935343

Fax: 886-3-5935342

Hwa Ya EMC/RF/Safety

Tel: 886-3-3183232

Fax: 886-3-3270892

Email: service.adt@tw.bureauveritas.com**Web Site:** www.bureauveritas-adt.com

The address and road map of all our labs can be found in our web site also.

--- END ---