



Network Printer (Symbol CF)  
AA16403-8

# INSTALL LABELS



The following operations should be performed at a grounded workstation, and the operator must wear an ESD strap.

Product I.D. Label  
p/n AA16403-tab  
refer to table

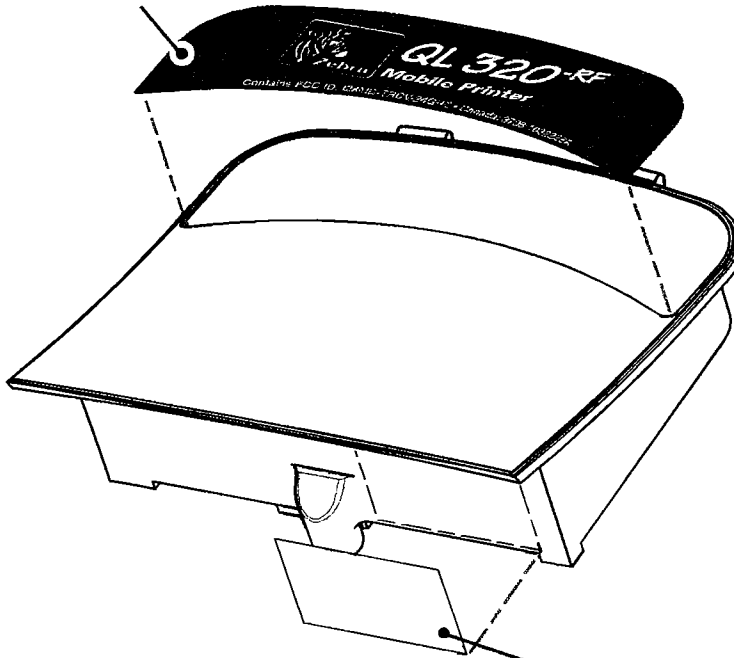

S/N Label  
p/n AC16328-tab  
refer to table

**Perform this step for all assemblies**

## Apply Product ID Label

Peel adhesive backing off the **Product ID Label** (p/n per table) and apply to the recess on the top of the Module housing.

## Apply Serial Number Label

Print the **Serial Number Label** called out in the table. (Refer to drawing AC16328-tab)

Assembly#	ID. Label	S/N Label
CC16225-1	AA16403-6	AC16328-1
CC16226-1	AA16403-5	AC16328-2
CC16227-1	AA16403-4	AC16328-3
CC16232-1	AA16403-8	AC16328-4

Apply the Serial Number Label approximately where shown on the Module Housing.

***This completes the QL Series Wireless Module assembly. Completed assemblies should be stored in static proof bags or containers and handled only by personnel at a properly grounded work station.***

## QL 320 PCC LEVEL - LABELS AND BATTERY

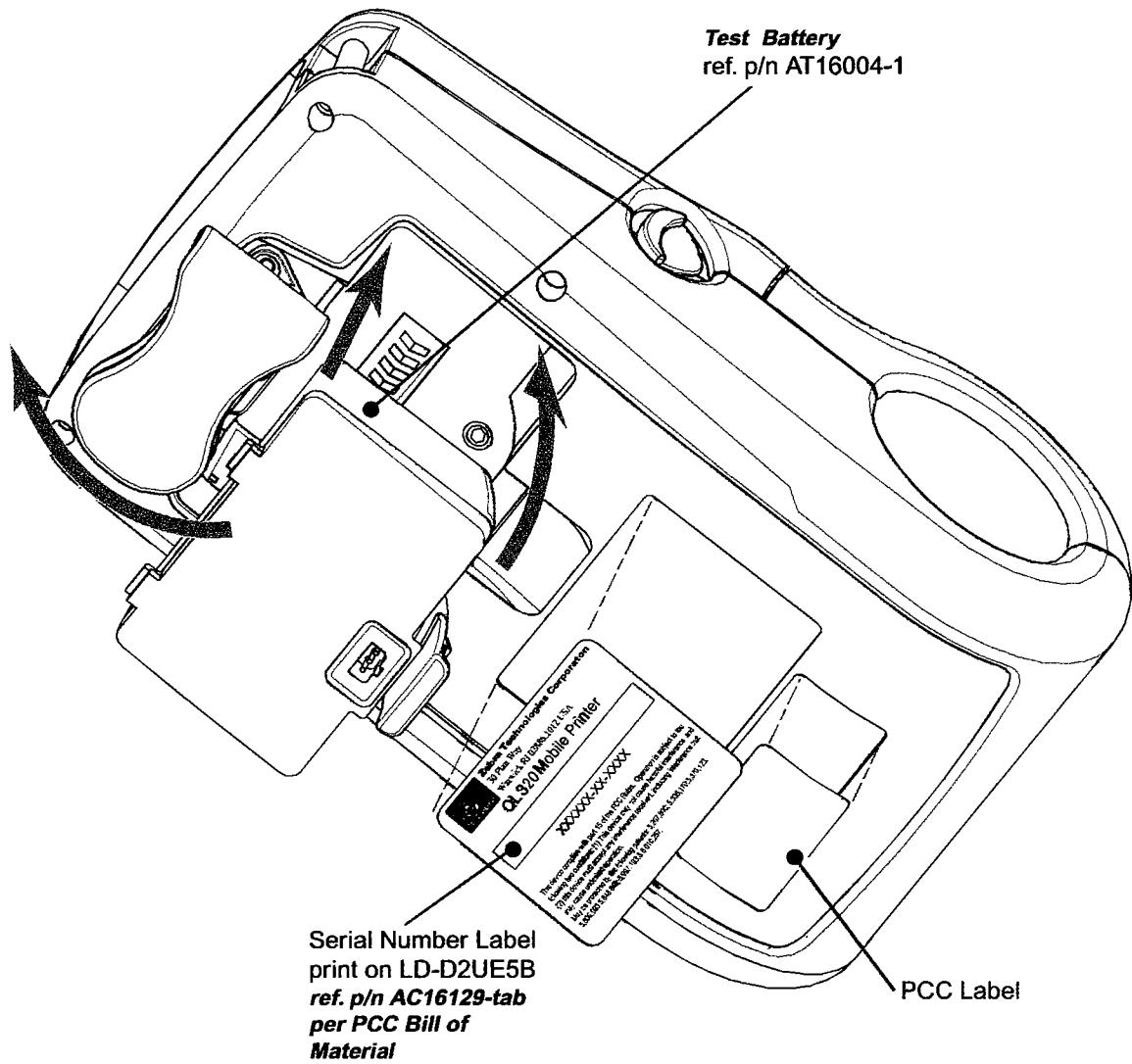

### **Install the Serial Number and PCC Label**

Print the **Serial Number Label** from the appropriate file and attach it to the bottom of the printer with text facing as shown. Cover the Label with an Overlay.

Print the correct configuration code on the PCC Label and attach to recess in bottom of unit as shown.

### **Install the Test Battery Pack.**

If the unit has the Belt Clip option, rotate the Belt Clip to clear the battery compartment.

Insert a test battery pack as shown, and rotate the clip end of the pack into the battery compartment until the battery locks in place. Unit must be sent to Unit Test.

### **This concludes the QL 320 PCC (Configurator) Level Assembly**

This drawing contains confidential and other data of a proprietary nature owned by Zebra Technologies Corporation, and may not be used or disclosed to others without the prior written consent of Zebra Technologies Corporation.

Part Number	Description
AC16129-1	QL 320 Generic

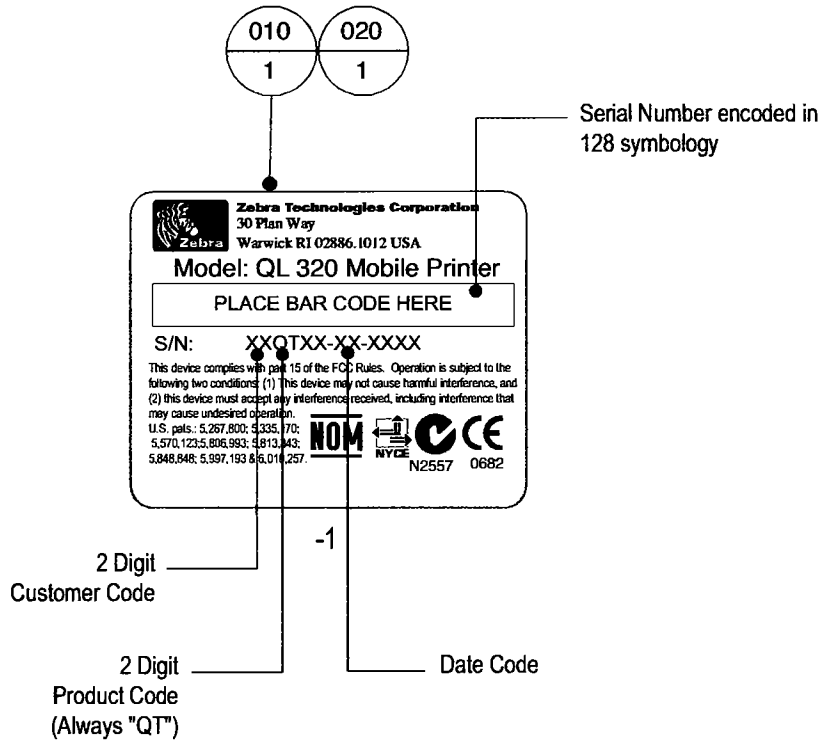

G	per ECO18337	gf		5/2/02
F	per ECO 18034	gf	AAR	2/12/02
E	per ECO 17965	gf	AAR	1/25/02
D	per ECO 17566	gf	AAR	10/3/01
C	per ECO 17506	gf	AAR	9/26/01
B	per ECO 17417	gf	AAR	8/16/01
A	per ECO 17390	gf	AAR	8/81/01
1	initial release	gf		8/31/01
rev	Change	Dwn.	Appvd.	Date



**Zebra Technologies Corporation**  
 30 Plan Way Warwick, RI 02886.1012 U.S.A.  
 Telephone +1.401.739.5800 Facsimile +1.401.732.0145  
 www.zebra.com

Description: QL 320 Serial Number Label  
 Part Number: AC16129-tab

File Name: C16129GT.pdf

Rev. G