

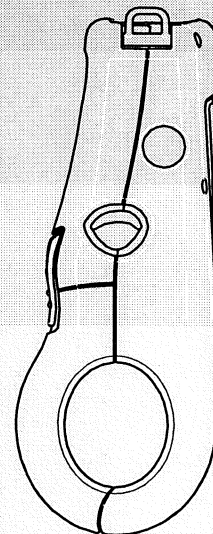

QL 320tm

Mobile Printer User's Guide

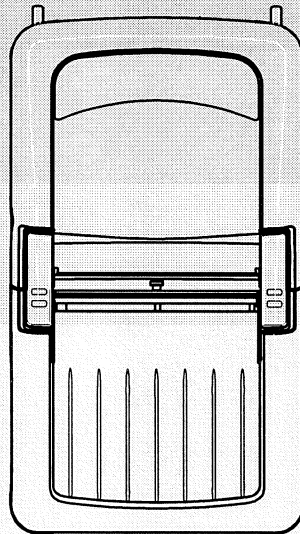
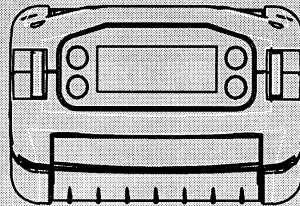

UMAN-QL3

Rev.D March, 2002

Proprietary Statement

This manual contains proprietary information of Zebra Technologies Corporation. It is intended solely for the information and use of parties operating and maintaining the equipment described herein. Such proprietary information may not be used, reproduced, or disclosed to any other parties for any other purpose without the expressed written permission of Zebra Technologies Corporation.

Product Improvements

Since continuous product improvement is a policy of Zebra Technologies Corporation, all specifications and signs are subject to change without notice.

FCC Compliance Statement

NOTE: This equipment has been tested and found to comply with the limits for a Class A digital device, pursuant to Part 15 of FCC Rules. These limits are designed to provide reasonable protection against harmful interference when the equipment is operated in a commercial environment. This equipment generates, uses, and can radiate radio frequency energy and, if not installed and used in accordance with the instruction manual, may cause harmful interference to radio communications. Operation of this equipment in a residential area is likely to cause harmful interference in which case the user will be required to correct the interference at his own expense.

WARNING: Exposure to Radio Frequency radiation. To conform to FCC RF exposure requirements this device shall be used in accordance with the operating conditions and instructions listed in this manual.

NOTE: This unit was tested with shielded cables on the peripheral devices. Shielded cables must be used with the unit to insure compliance

Changes or modifications to this unit not expressly approved by Zebra Technologies Corporation could void the user's authority to operate this equipment.

Canadian Compliance Statement

"IC:" before the equipment certification number signifies that the Industry Canada technical specifications were met. It does not guarantee that the certified product will operate to the user's satisfaction.

Liability Disclaimer

Inasmuch as every effort has been made to supply accurate information in this manual, Zebra Technologies Corporation is not liable for any erroneous information or omissions. Zebra Technologies Corporation reserves the right to correct any such errors and disclaims liability resulting therefrom.

No Liability for Consequential Damage

In no event shall Zebra Technologies Corporation or anyone else involved in the creation, production, or delivery of the accompanying product (including hardware and software) be liable for any damages whatsoever (including, without limitation, damages for loss of business profits, business interruption, loss of business information, or other pecuniary loss) arising out of the use of or the results of use of or inability to use such product, even if Zebra Technologies Corporation has been advised of the possibility of such damages. Because some states do not allow the exclusion of liability for consequential or incidental damages, the above limitation may not apply to you.

Copyrights

The copyrights in this manual and the system described therein are owned by Zebra Technologies Corporation. All rights are reserved. Unauthorized reproduction of this manual or the software in any of the system modules may result in imprisonment of up to one year and fines of up to \$10,000 (17 U.S.C.506). Copyright violators may be subject to civil liability.

All products and brand names are trademarks of their respective companies. All rights reserved.

©2002 Zebra Technologies Corporation



QL 320tm

**Mobile Printer
User's Guide**

Contents

Introduction	7
Unpacking and Inspection	7
Reporting Damage	7
Getting Ready to Print.....	9
Battery	9
<i>Installing the Battery</i>	9
<i>Charging the Battery</i>	9
Loading the Media	10
<i>Installing the Media</i>	10
Operator Controls	13
<i>Standard Keypad</i>	13
<i>LCD Control Panel</i>	15
Verify the Printer Is Working	18
<i>Printing a Configuration Label</i>	18
Connecting the Printer	18
<i>Cable Communications</i>	19
<i>IR Communications</i>	20
<i>SRRF Communications</i>	21
<i>Zebra SRRF Network Overview</i>	21
<i>Bluetooth™ Networking Overview</i>	23
<i>Wireless Local Area Network (WLAN)</i>	25
Setting Up the Software	26
Adjustable Shoulder Strap	27
Belt Clip	28
Preventive Maintenance.....	29
Extending Battery Life	29
Cleaning	31
Troubleshooting	32
Standard Control Panel	32
Optional LCD Control Panel	32
Troubleshooting Topics	33
Troubleshooting Tests	34
<i>Printing a Configuration Label</i>	34
<i>Sample Configuration Label</i>	35
<i>Communications Diagnostics</i>	37
<i>Calling the Help Desk</i>	37
Specifications	38
Printing Specifications	38
Memory/Communications Specifications	38

Label Specifications	39
Font/Bar Code Specifications	39
Physical/Environmental/Electrical Specifications	40
Communications Port	41
Agency Approvals	42
Accessories	42
Appendix A	43
<i>Interface Cables</i>	
Appendix B	46
<i>Media Supplies</i>	
Appendix C	47
<i>Maintenance Supplies</i>	
Appendix D	48
<i>Product Support</i>	
Index	49
Patent Information	51

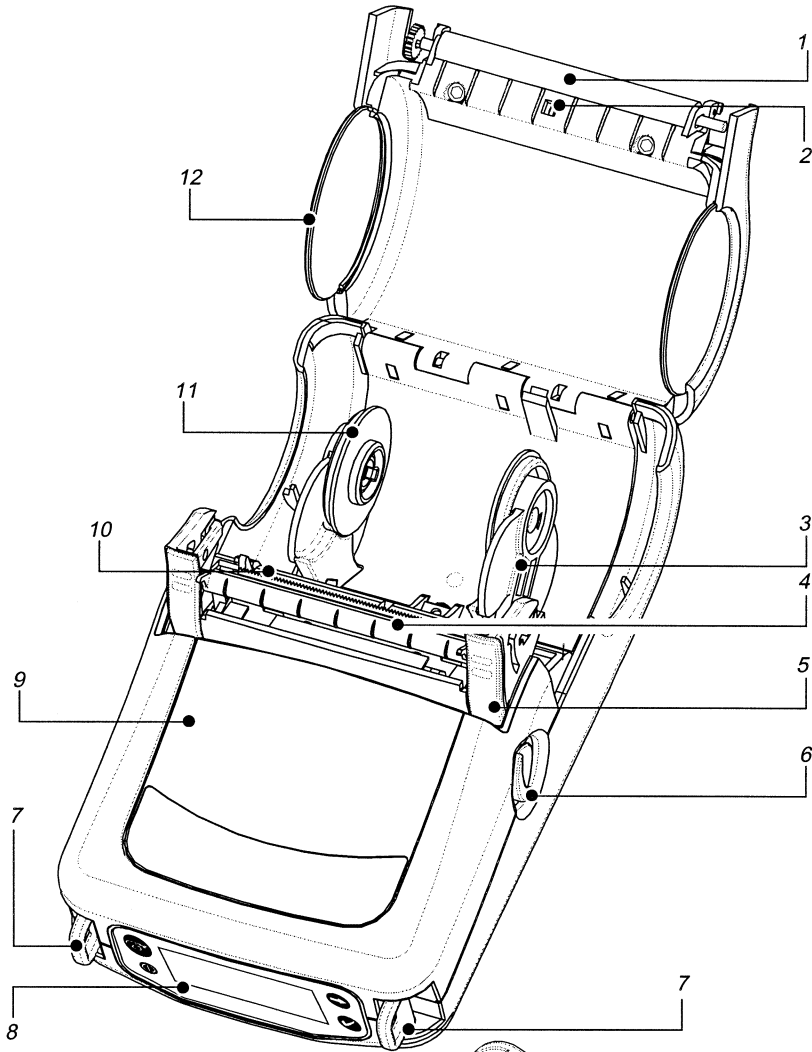

- 1 Platen Roller
- 2 Bar Sensor
- 3 Media Support
- 4 "EZ-Peel" Peeler
- 5 Latch
- 6 Latch Release Lever
- 7 "D" Rings
- 8 Control Panel
- 9 QuickLink Module
- 10 Print Head
- 11 Media Support Disks
- 12 Media Cover
- 13 Belt Clip
- 14 Battery
- 15 Battery Charging Receptacle

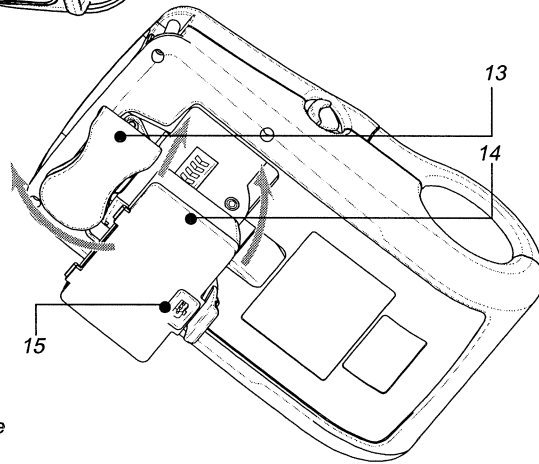

Introduction

Thank you for choosing our Zebra QL 320 Mobile Printer. This rugged printer is sure to become a productive and efficient addition to your workplace thanks to its innovative design. Because it's made by Zebra Technologies Corporation, you're assured of world-class support for all of your bar code printers, software, and supplies.

- This user's guide gives you all the information you'll need to operate the QL 320 printer.
- The QL 320 uses the CPL programming language. To create and print labels using the CPL language, refer to the Mobile Printer Programming Guide and our Label Vista™ label creation program.
- The QL 320 has an optional interpreter for the ZPL II® Programming Language which interprets commands up to X.8 firmware. The printer must be equipped with the optional memory upgrade and appropriate application in order to use this function. A ZPL II Program Guide (part #46530L) can be used as reference for the ZPL II label design programming language. If either manual was not ordered with the printer, simply call your re-seller or Zebra Technologies Corporation or visit the Zebra web site..

Unpacking and Inspection

Inspect the printer for possible shipping damage:

- Check all exterior surfaces for damage.
- Open the media cover (refer to "Loading the Media" in the Getting Ready to Print section) and inspect the media compartment for damage.

In case shipping is required, save the carton and all packing material.

Reporting Damage

If you discover shipping damage:

- Immediately notify and file a damage report with the shipping company. Zebra Technologies Corporation is not responsible for any damage incurred during shipment of the printer and will not cover the repair of this damage under its warranty policy.
- Keep the carton and all packing material for inspection.
- Notify your authorized Zebra re-seller.

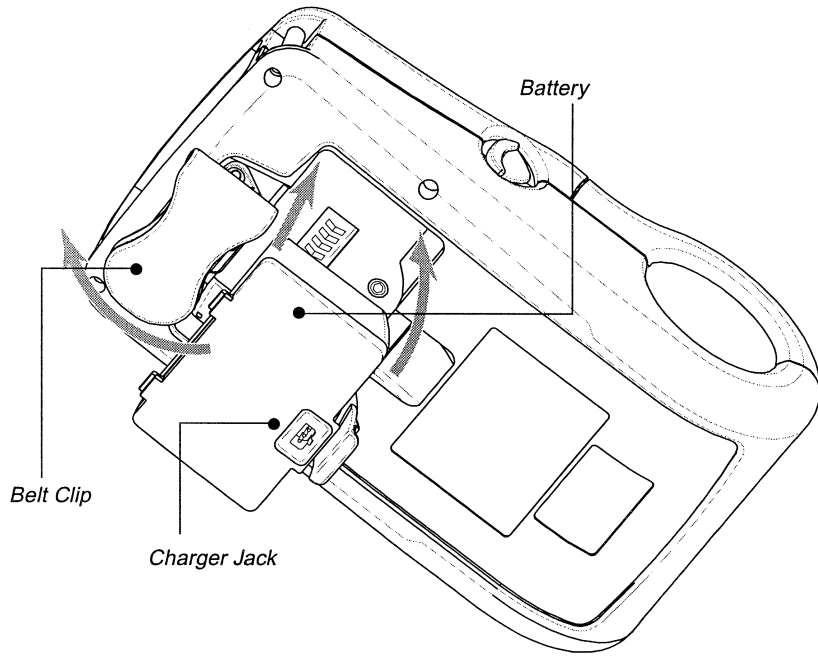

FIGURE 2

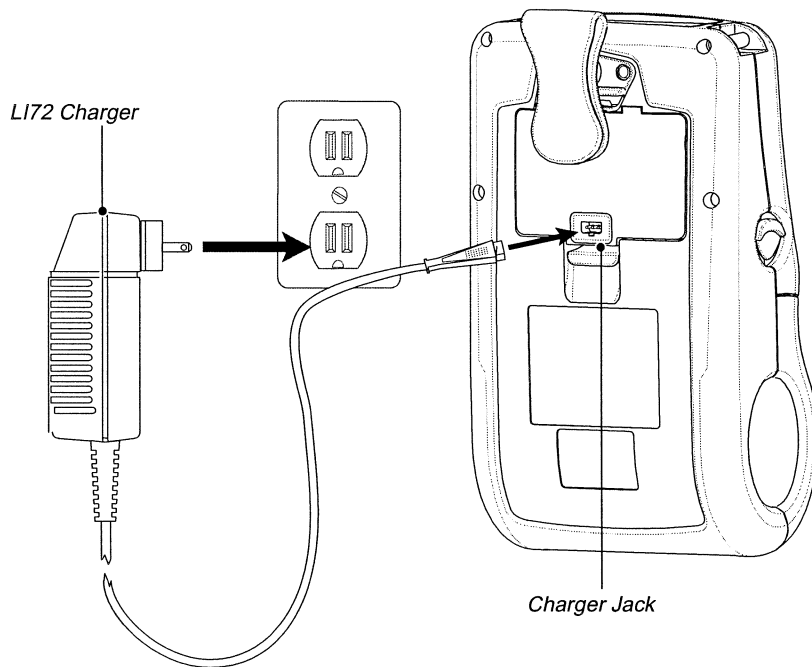



FIGURE 3

Getting Ready to Print

Battery

Installing the Battery

 **NOTE:** Batteries are shipped uncharged. Remove protective shrink-wrap and labels from new battery packs prior to use.

1. If the printer is so equipped, rotate the Belt Clip to allow access to the Battery compartment.
2. Insert the battery into the printer as shown in Figure 2,
3. Rock the Battery into the printer as shown until it locks in place.

When the battery is first installed, the Control Panel indicators may briefly turn on and then go off which indicates the battery is not fully charged (see “Charging the Battery” below and “Operator Controls”).

Charging the Battery

Refer to Figure 3. Your battery charger may look slightly different from the ones illustrated.

If you are using the LI 72 battery charger:

1. Install the battery in the printer and plug the Charger into the appropriate A.C. wall receptacle. Then insert the charge cable into the battery charger jack.
2. The charger LED will indicate the status of the charger as follows:
 - A steady light indicates the battery is undergoing a fast charge.
 - A slow blinking light indicates the charger is in trickle mode. The battery is ready for use.
 - A rapidly blinking light indicates a problem with the battery. The battery may have an internal short, or its charge monitoring circuitry may be malfunctioning. The battery should not be used any further.
 - Battery Packs may be charged either when installed in the printer or when removed.



Do not attempt to charge batteries with the LI 72 while printing. Attempting to print while charging can result in improperly charged batteries.

Loading the Media

You can operate this printer in one of two different modes: Tear-Off or Peel-Off. Tear-Off mode allows you to tear off each label (or a strip of labels) after it is printed. In Peel-Off mode, the backing material is peeled away from the label as it is printed. After you remove this label, the next one is printed.

Installing the Media

1. Refer to Figure 4. Open the printer:

- Rotate the latch release levers on each side of the printer as shown at “1” below.

The latch assembly will flip open automatically as shown at “2”.

- Rotate the media Cover back as shown at “3”, exposing the media compartment and the adjustable media supports.

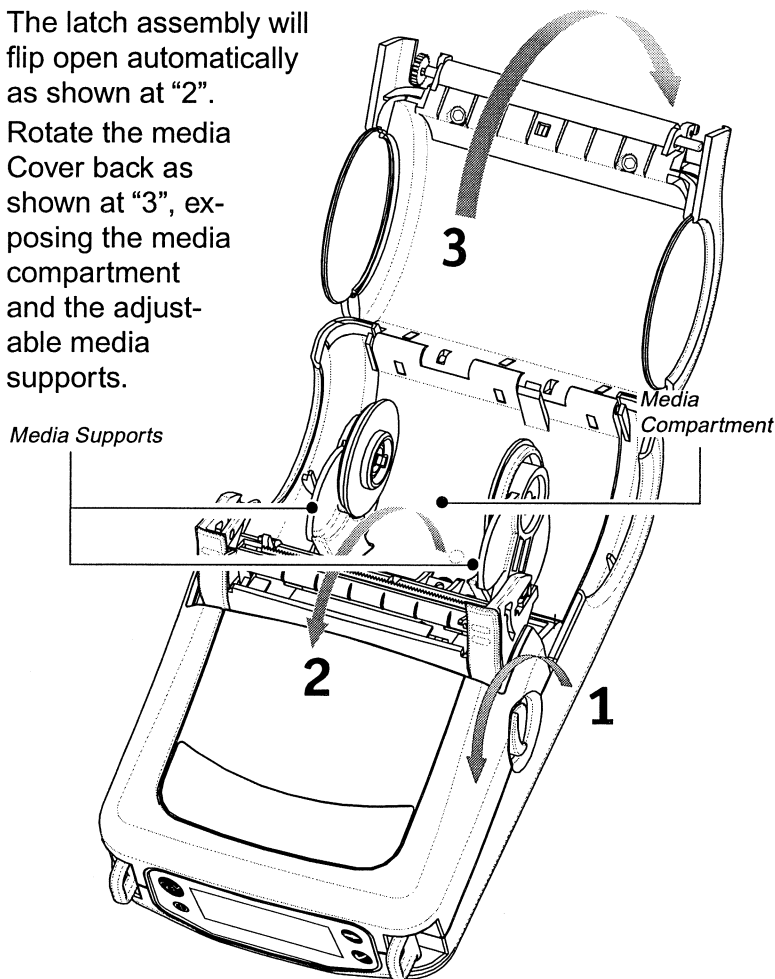

FIGURE 4

2. Refer to Figure 5. Load the media

- Determine that the core diameter of the media roll matches the setting of the Media Disks. If it does not, adjust the media disks per Figure 6 below.
- If the media support setting is correct, pull the media supports apart, insert the roll of media between them, and let the media supports close. Insure that the media pulls off the core in the direction shown in Figure 5. The supports will adjust themselves to the width of the media, and the media should be able to spin freely on the supports.

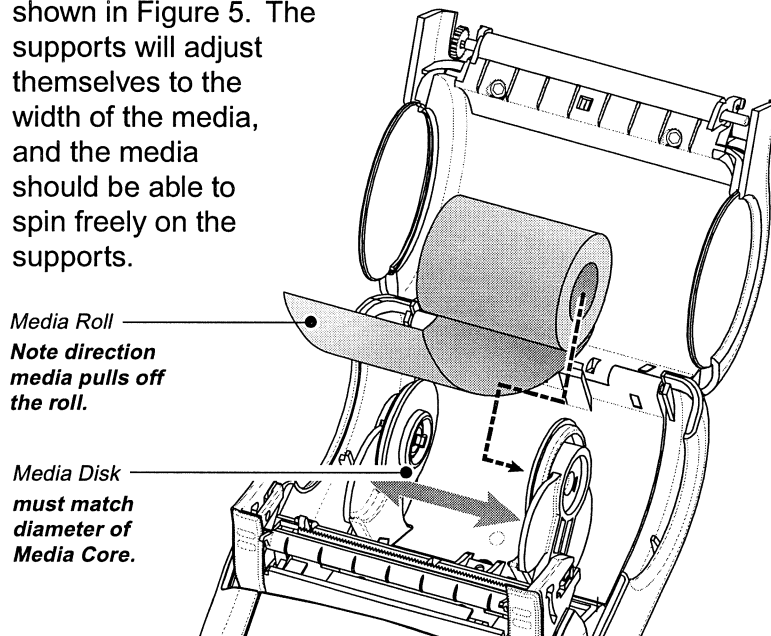
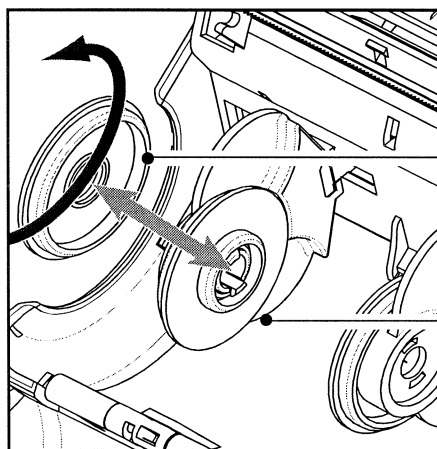

FIGURE 5



Remove Media Disk, rotate 180° and replace for 1.40" core

Media Disk set for 3/4" core (factory default).

FIGURE 6

continued on next page

3. Refer to Figure 7. Close the Media Cover

- If you plan to use the printer in the tear-off mode, close the media cover as shown at “2”, then rotate the latch assembly as shown until it locks into place, as shown at “4”.
- If you plan to use the printer in the peel-off mode, peel a few labels off of the media roll and pull it out of the printer as shown at “1”. Close the media cover as shown at “2”. Rotate the “EZ-Peel” peeler bar until it locks into place on the latch, as shown at “3”, then rotate the Latch as shown until it locks into place, as shown at “4”.
- Turn on the printer or press the Feed button if the printer is already on.

The printer will advance the media to the next label, if printing labels. If you are printing on journal media, the printer will advance a short strip of media and will then be ready for printing.

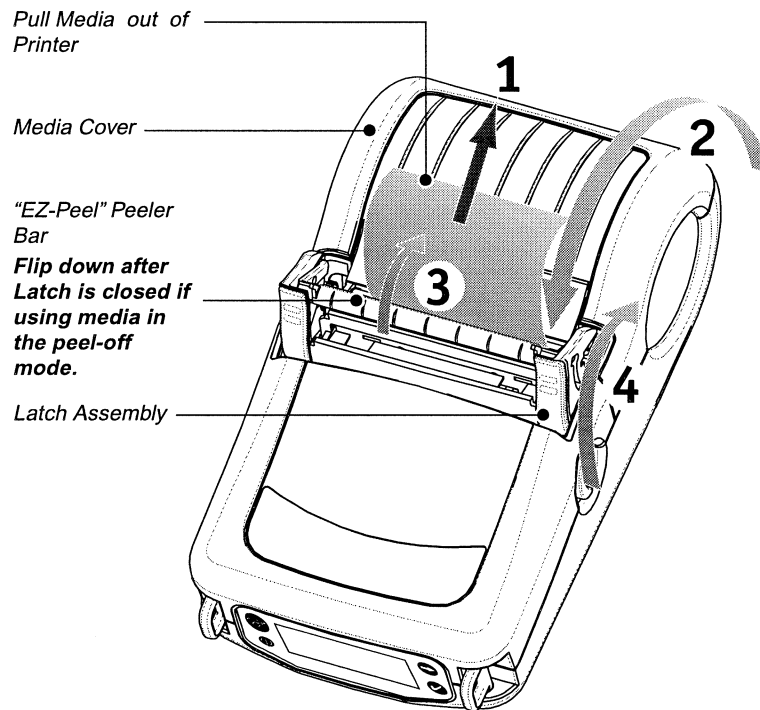

FIGURE 7

Operator Controls

The QL 320 will come with one of two possible control panels. The standard control panel is detailed below and in Figure 8. The optional control panel (Figure 9) features an LCD which allows easy display and selection of many printer functions and is detailed on following pages.

Standard Keypad

The standard keypad has three control buttons and two multi-purpose indicators.

- The Power button turns the QL 320 on and off.
- The Feed button advances a length of media which is determined by the type of media being used. Label media will be advanced to the next gap or bar sense marker. Journal (plain) media will be advanced a length determined by the printer's software.
- The Function button is controlled by a printer's specific application to support such functions as:
 - Print a battery Level reporting
 - Print the Local Area Network (LAN) status
 - Print a Short Range Radio Frequency (SRRF) status
 - Print a Media supply report

The green LED on the left side of the control panel indicates the status of several printer features:

- A slowly blinking sequence indicates the printer's battery needs charging.
- Printers with a wireless QuickLink module installed: a quickly blinking sequence indicates the printer has not established a link to either a Local Area Network or a compatible wireless equipped terminal.
- Printers with a wireless QuickLink module installed: A steadily lit indicator shows that the printer has established a wireless link, either to the LAN or to a compatible terminal. A steadily lit green indicator on a non-wireless printer is a power-on indicator.

The yellow LED on the right side of the control panel has two indication conditions.

- A rapidly blinking yellow LED and a chime indicate that no application has been loaded into the printer.
- Printers with a wireless QuickLink module installed: a rapidly blinking LED indicates normal data transmission.

- A steadily lit yellow LED indicates an error condition. This can be caused by one of the following:
 1. The media cover is not completely closed and latched.
 2. The printer is out of media.

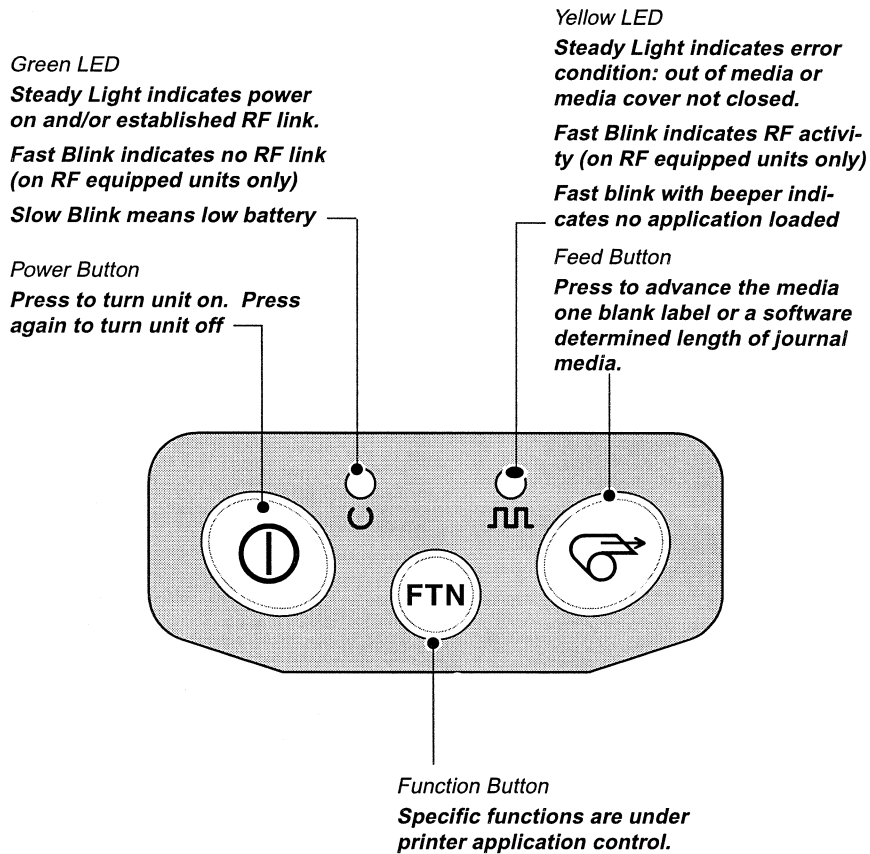

FIGURE 8: STANDARD CONTROL PANEL

LCD Control Panel

The optional LCD control panel has buttons for the power on/off and media feed functions just as in the standard control panel. In addition, it has two keys which allow easy navigation and selection of menu options affecting many printer functions.

The “Scroll” button allows scrolling through the various options and settings. The “Select” button allows selection of the option or function displayed on the screen.

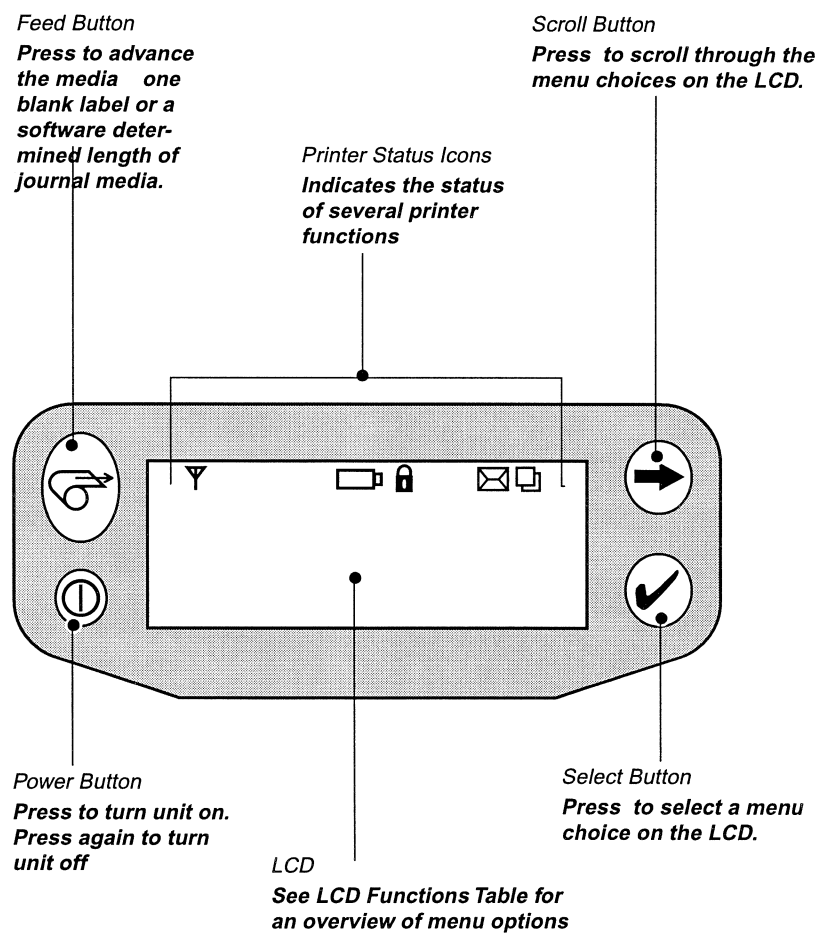





FIGURE 9: OPTIONAL LCD CONTROL PANEL

The top of the screen has a row of status icons which indicate the state of various printer functions:

 Indicates that the printer is associated with a wireless Local Area Network (LAN). This icon is functional only with QL 320N network printers.

 A flashing icon indicates low battery status. You should suspend any printing operations and recharge or replace the battery Pack as soon as is convenient.

 A flashing icon indicates that the media cover is open or not properly latched.

 A flashing icon indicates that a file is being downloaded to the printer.

 A flashing icon indicates that the printer does not detect any media. This could indicate an out of media condition, or improperly loaded media.

In addition to the status icons, the LCD control panel can display many of the printer's settings and functions as text. Applications can be written to allow the user to view and /or modify these settings using the scroll and select keys on the display. Refer to the "LCD Functions Table" on the following page for the full set of printer features that can be made available with the LCD panel.

The LCD has a backlighting option which allows viewing of the screen in a dark environment, or provides better contrast in a very bright environment. Use of the display backlight will decrease the time the printer will run between charges.

LCD Functions		
Function	Default setting	Scroll & Select Options
Sensor Type	Gap	<ul style="list-style-type: none"> • Bar • Gap
Print Width	Factory Set Value	<ul style="list-style-type: none"> • Increase (+120 dots max.) • Decrease (-120 dots max.)
Baud Rate	19200	<ul style="list-style-type: none"> • 9600 • 19200 • 32400
Data Bits	8	<ul style="list-style-type: none"> • 7 • 8
WLAN ID*	Factory Set Value	N/A
Label Top	000	<ul style="list-style-type: none"> • Increase (+120 dots max.) • Decrease (-120 dots max.)
Left Position	000	<ul style="list-style-type: none"> • Increase (+120 dots max.) • Decrease (-120 dots max.)
LCD Contrast	0	<ul style="list-style-type: none"> • Increase • Decrease
No-activity Timeout	60 sec.	<ul style="list-style-type: none"> • 60 sec. • 5 min. • 10 min. • 30 min • Custom*
Print Darkness (Head Temperature)	00	<ul style="list-style-type: none"> • Increase (+10 max.) • Decrease (-10 max.)
Tear-off Position	00	<ul style="list-style-type: none"> • Increase (+120 dots max.) • Decrease (-120 dots max.)
Media Type	Label	<ul style="list-style-type: none"> • Label • Journal
LCD Backlight	Off	<ul style="list-style-type: none"> • On • Off • Momentary On w/ time delay
Factory Reset (Resets all to factory set values)	No	<ul style="list-style-type: none"> • No • Yes

* Some parameters, such as the WLAN ID number and non-standard no-activity time out values can be set using a PC running Zebra's Label Vista label creation program and a data cable link to the printer.

Verify the Printer Is Working

Before you connect the printer to your computer or portable data terminal, make sure that the printer is in proper working order. You can do this by printing a configuration label using the “two key reset” method. If you can’t get this label to print, refer to “Troubleshooting”.

Printing a Configuration Label

1. Turn the printer off. Load the media compartment with journal media (media with no black bars printed on the back)
2. Press and hold the Feed Button.
3. Press and release the Power button and keep the Feed button pressed. When printing starts, release the Feed button.

The unit will print a line of interlocking “x” characters to insure all elements of the print head are working, print out the version of software loaded in the printer and then print two reports.

The first report indicates model, ROM version, serial number, baud rate, etc. The second report prints out more detailed information on the printer’s configuration and parameter settings. If no second report appears, there is no application loaded. (See the Troubleshooting Section for a sample print-out and a further discussion on how to use the configuration label as a diagnostic tool.)

Connecting the Printer

The printer must establish communications with a host terminal which sends the data to be printed. Communications occur in four basic ways:

- By a cable between the printer and its host terminal
- Linking to a host terminal via Infrared (usually by means of the industry standard IrDA protocol)
- By means of a Short Range Radio Frequency (SRRF) link.
- By means of a wireless LAN (Local Area Network). This applies to QL 320N Network Printers only.