

FCC Test Report

EQUIPMENT : Mobile Computer
BRAND NAME : Symbol
MODEL NAME : FR6076
FCC ID : H9PFR6076
STANDARD : FCC Part 15 Subpart C §15.247
CLASSIFICATION : Digital Transmission System (DTS)
APPLICANT : Symbol Technologies, Inc., A Motorola Company
230 Victoria Street #12-06/10 Bugis Junction Office Tower
Singapore 188024

The product sample received on Oct. 31, 2008 and completely tested on Feb. 10, 2009. We, SPORTON INTERNATIONAL INC., would like to declare that the tested sample has been evaluated in accordance with the procedures given in ANSI C63.4-2003 and shown the compliance with the applicable technical standards.

The test results in this report apply exclusively to the tested model / sample. Without written approval of SPORTON INTERNATIONAL INC., the test report shall not be reproduced except in full.

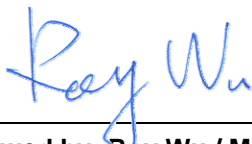

Reviewed by: Roy Wu / Manager



SPORTON INTERNATIONAL INC.

No. 52, Hwa Ya 1st Rd., Hwa Ya Technology Park, Kwei-Shan Hsiang, Tao Yuan Hsien, Taiwan, R.O.C.



TABLE OF CONTENTS

- SUMMARY OF TEST RESULT 3**
- REVISION HISTORY..... 4**
- 1 GENERAL DESCRIPTION 5**
 - 1.1 Applicant 5
 - 1.2 Manufacturer..... 5
 - 1.3 Feature of Equipment Under Test 5
 - 1.4 Testing Site..... 7
 - 1.5 Applied Standards 7
 - 1.6 Ancillary Equipment List 7
- 2 TEST CONFIGURATION OF EQUIPMENT UNDER TEST 8**
 - 2.1 Pre-Scanned RF Power..... 8
 - 2.2 Test Mode..... 9
 - 2.3 Connection Diagram of Test System..... 10
 - 2.4 RF Utility 11
- 3 TEST RESULT..... 12**
 - 3.1 6dB Bandwidth Measurement 12
 - 3.2 Output Power Measurement..... 17
 - 3.3 Band Edges Measurement 22
 - 3.4 Power Spectral Density Measurement 27
 - 3.5 AC Conducted Emission Measurement..... 32
 - 3.6 Radiated Emission Measurement..... 40
 - 3.7 Antenna Requirements..... 66
- 4 LIST OF MEASURING EQUIPMENTS 67**
- 5 UNCERTAINTY OF EVALUATION 68**
- 6 CERTIFICATION OF TAF ACCREDITATION 70**
- APPENDIX A. PHOTOGRAPHS OF EUT**
- APPENDIX B. SETUP PHOTOGRAPHS**



SUMMARY OF TEST RESULT

Report Section	FCC Rule	IC Rule	Description	Limit	Result	Remark
3.1	15.247(a)(2)	A8.2(a)	6dB Bandwidth	$\geq 0.5\text{MHz}$	Pass	-
3.2	15.247(b)	A8.4	Power Output	$\leq 30\text{dBm}$	Pass	-
3.3	15.247(d)	A8.5	Frequency Band Edges	$\leq 20\text{dBc}$	Pass	-
3.4	15.247(e)	A8.2(b)	Power Spectral Density	$\leq 8\text{dBm}$	Pass	-
3.5	15.207	Gen 7.2.2	AC Conducted Emission	15.207(a)	Pass	Under limit 14.3 dB at 0.702 MHz
3.6	15.247(d)	A8.5	Transmitter Radiated Emission	15.209(a) & 15.247(d)	Pass	Under limit 7.29 dB at 8937.00 MHz
3.7	15.203 & 15.247(b)	A8.4	Antenna Requirement	N/A	Pass	-

1 General Description

1.1 Applicant

Symbol Technologies, Inc., A Motorola Company

230 Victoria Street #12-06/10 Bugis Junction Office Tower Singapore 188024

1.2 Manufacturer

Inventec Appliances Corp.

No. 37, Wugong 5th Road, Wugu Industrial Park, Taipei Country 248, Taiwan, R.O.C.

1.3 Feature of Equipment Under Test

Product Feature & Specification	
Equipment	Mobile Computer
Brand Name	Symbol
Model Name	FR6076
Tx/Rx Frequency Range	2400 MHz ~ 2483.5 MHz
Number of Channels	11
Carrier Frequency of Each Channel	2412+(n-1)*5 MHz; n=1~11
Channel Spacing	5 MHz
Maximum Output Power to Antenna	802.11b : 14.61 dBm 802.11g : 13.48 dBm
Antenna Type	PIFA Antenna with gain -4 dBi
Type of Antenna Connector	N/A
HW Version	DVT
SW Version	Modem: 0029-010709-M OS: Handy-DVT1-0.31.0057-020209-WWE-H
Type of Modulation	802.11b : DSSS (BPSK / QPSK / CCK) 802.11g : OFDM (BPSK / QPSK / 16QAM / 64QAM)
EUT Stage	Identical Prototype

Accessories List:

Cradle	Brand Name	Symbol
	Model Name	CRD7X00-1
	Power Rating	12Vdc, 3.33A
Cradle Adapter	Brand Name	HIPRO
	Model Name	HP-O2040D43
	Power Rating	I/P: 100-240Vac, 50-60Hz, 1.5A; O/P: 12V, 3.33A
	Power Cord Type	1.8 meter shielded cable with ferrite core
Product Charging Adapter	Brand Name	MOTOROLA
	Model Name	EADP-16BB A
	Power Rating	I/P: 100-240Vac, 50-60Hz, 0.4A; O/P: 5.4V, 3A
Product Charging Cable 1	Power Cord Type	1.83 meter shielded cable without ferrite core
	Brand Name	MOTOROLA
	Part Number	25-102775-01R
Product Charging Cable 2	Power Rating	I/P: 5.4V, 3A
	Power Cord Type	1.35 meter non-shielded cable with ferrite core
	Brand Name	MOTOROLA
Battery	Part Number	25-118708-01R
	Power Rating	I/P: 5.4V, 3A
	Power Cord Type	1.35 meter non-shielded cable with ferrite core
Earphone	Brand Name	MOTOROLA
	Part Number	82-71364-05
	Power Rating	3.7Vdc, 3600mAh, 13.3Wh
	Type	Li-ion
USB Cable	Brand Name	Symbol
	Part Number	90-17C28-001R
	Signal Line Type	1.24 meter non-shielded cable without ferrite core
USB Cable	Brand Name	MOTOROLA
	Part Number	25-68596-01R
	Type	1.58 meter shielded cable without ferrite core

Remark:

1. The above EUT's information was declared by manufacturer. Please refer to the specifications or user's manual for more detailed description.
2. This test report recorded only product characteristics and test results of Digital Transmission System (DTS).
3. For accessories equipped with this EUT, please refer to the appendix of the external photo.
4. Product Charging Cable 1 (P/N: 25-102775-01R) and Product Charging Cable 2 (P/N: 25-118708-01R) are exactly the same which was declared by the manufacturer, and only Product Charging Cable 1 (P/N: 25-102775-01R) was performed on all the tests.

1.4 Testing Site

Test Site	SPORTON INTERNATIONAL INC.		
Test Site Location	No. 52, Hwa Ya 1 st Rd., Hwa Ya Technology Park, Kwei-Shan Hsiang, Tao Yuan Hsien, Taiwan, R.O.C TEL: +886-3-3273456 / FAX: +886-3-3284978		
Test Site No.	Sporton Site No.		FCC/IC Registration No.
	CO05-HY	03CH07-HY	TW1022/4086B-1

1.5 Applied Standards

According to the specifications of the manufacturer, the EUT must comply with the requirements of the following standards:

- ♦ FCC Part 15 Subpart C §15.247
- ♦ FCC KDB Publication No. 558074 (Measurement Guidelines of DTS)
- ♦ ANSI C63.4-2003
- ♦ IC RSS-210 Issue 7

Remark:

1. All test items were verified and recorded according to the standards and without any deviation during the test.
2. This EUT has also been tested and complied with the requirements of FCC Part 15, Subpart B (DoC), recorded in a separate test report.

1.6 Ancillary Equipment List

Equipment	Brand Name	Model Name	FCC ID	Data Cable	Power Cord
System Simulator	R&S	CMU200	N/A	N/A	Unshielded, 1.8 m
WLAN AP	D-Link	DWL-7100AP	KA22003040018-1	N/A	Unshielded, 1.8 m
GPS Station	SPIRENT	GSS4200	N/A	N/A	Unshielded, 1.8 m
Notebook	DELL	Vostro 1510	FCC DoC	N/A	AC I/P: Unshielded, 1.2 m DC O/P: Shielded, 1.8 m
LCD Monitor	Lenovo	6135-AB1	FCC DoC	N/A	Unshielded, 1.8m
Bluetooth Earphone	Cellink	BTHS-6025-F	PQY-4710874200357	N/A	N/A
i-pod	Apple	A1199	FCC DoC	Unshielded, 1.0 m	N/A

2 Test Configuration of Equipment Under Test

2.1 Pre-Scanned RF Power

Preliminary tests were performed in different data rate and recorded the RF power output in the following table:

802.11b

Channel	Frequency (MHz)	RF Power (dBm)			
		2.4GHz 802.11b Data Rate			
		1 Mbps	2 Mbps	5.5 Mbps	11 Mbps
CH 01	2412 MHz	11.09	11.10	12.41	12.73
CH 06	2437 MHz	10.59	10.72	12.03	12.40
CH 11	2462 MHz	12.90	12.97	14.10	14.61

802.11g

Channel	Frequency (MHz)	RF Power (dBm)							
		2.4GHz 802.11g Data Rate							
		6 Mbps	9 Mbps	12 Mbps	18 Mbps	24 Mbps	36 Mbps	48 Mbps	54 Mbps
CH 01	2412 MHz	9.97	10.66	10.86	10.84	11.33	11.81	11.62	11.17
CH 06	2437 MHz	8.86	10.32	10.11	10.60	10.54	10.65	11.27	10.95
CH 11	2462 MHz	11.8	12.52	12.86	12.66	13.20	12.90	13.48	13.18

Remark:

1. The EUT is programmed to transmit signal continuously for all testing.

2.2 Test Mode

The EUT has been associated with peripherals pursuant to ANSI C63.4-2003 and configuration operated in a manner tended to maximize its emission characteristics in a typical application. Frequency range investigated: conducted emission (150 kHz to 30 MHz), radiated emission (30 MHz to the 10th harmonic of the highest fundamental frequency or to 40 GHz, whichever is lower). Pre-scanned tests were conducted to determine the final configuration from all possible combinations. The following tables are showing the test modes as the worst cases and recorded in this report.

Test Cases		
Test Item	Modulation	
	802.11b DSSS	802.11g OFDM
Conducted TCs	<ul style="list-style-type: none"> ■ Mode 1: CH01_2412 MHz ■ Mode 2: CH06_2437 MHz ■ Mode 3: CH11_2462 MHz 	<ul style="list-style-type: none"> ■ Mode 4: CH01_2412 MHz ■ Mode 5: CH06_2437 MHz ■ Mode 6: CH11_2462 MHz
Radiated TCs	<ul style="list-style-type: none"> ■ Mode 1: CH01_2412 MHz ■ Mode 2: CH06_2437 MHz ■ Mode 3: CH11_2462 MHz 	<ul style="list-style-type: none"> ■ Mode 4: CH01_2412 MHz ■ Mode 5: CH06_2437 MHz ■ Mode 6: CH11_2462 MHz
AC Conducted Emission	Mode 1 : GSM 850 Idle + GPS Rx + BT Link + WLAN Link + Earphone + Cradle + Adapter + USB Cable Mode 2 : GSM 850 Idle + GPS Rx + BT Link + WLAN Link + Earphone + USB Charging Cable with AC Power Mode 3 : WCDMA Idle + GPS Rx + BT Link + WLAN Link + Earphone + Cradle + Adapter + USB Cable	

2.3 Connection Diagram of Test System

<Conducted Emission>

EUT with Cradle Mode

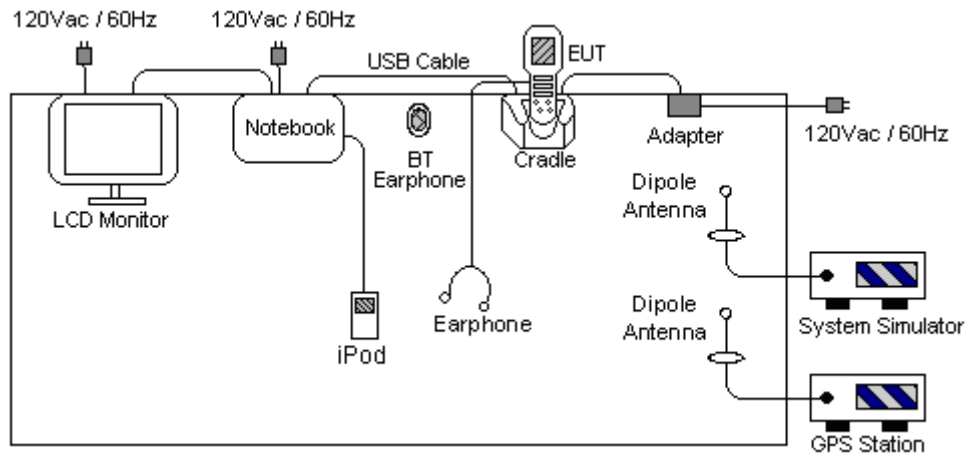

EUT with USB Charging cable Mode

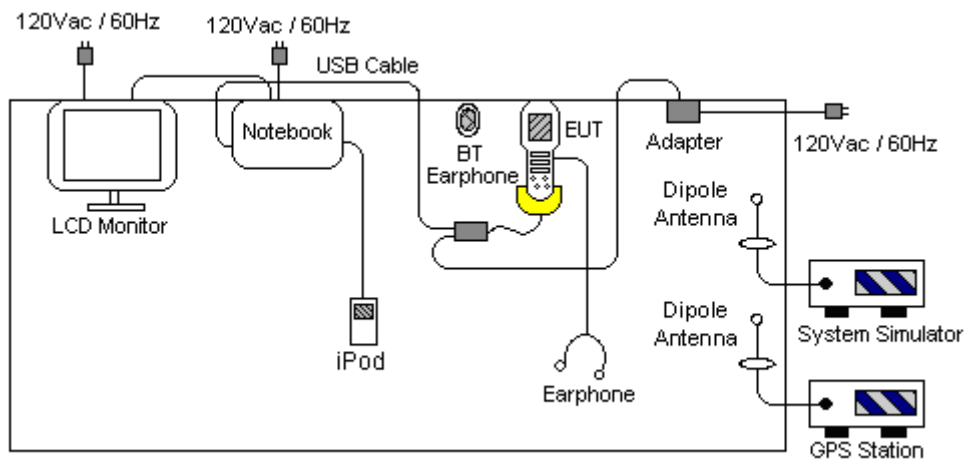

<Radiated Emission>

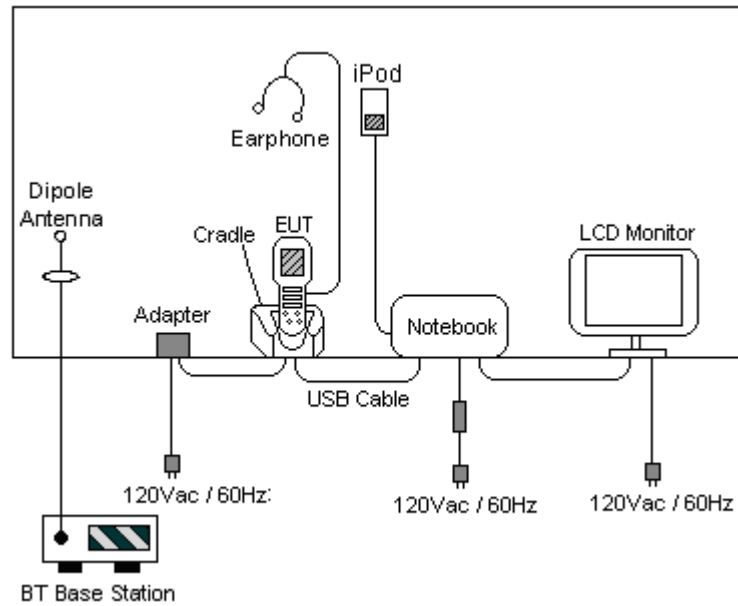

2.4 RF Utility

The programmed RF utility "My lab tool" installed in EUT to provide channel selection, power level, data rate and the application type. RF utility can send transmitting signal for all testing. The RF output power selection is for the setting of RF output power expected by the customer and is going to be fixed on the firmware of the final end product.

3 Test Result

3.1 6dB Bandwidth Measurement

3.1.1 Limit of 6dB Bandwidth

The minimum 6 dB bandwidth shall be at least 500 kHz.

3.1.2 Measuring Instruments

See list of measuring instruments of this test report.

3.1.3 Test Procedures

1. The testing follows FCC KDB Publication No. 558074 (Measurement Guidelines of DTS).
2. The RF output of EUT was connected to the spectrum analyzer by a low loss cable.
3. Make the measurement with the spectrum analyzer's resolution bandwidth (RBW) = 100 kHz.
In order to make an accurate measurement, set the span greater than RBW. The 6 dB bandwidth must be greater than 500 kHz.
4. The marker-delta reading at this point is the 6 dB bandwidth of the emission.

3.1.4 Test Setup

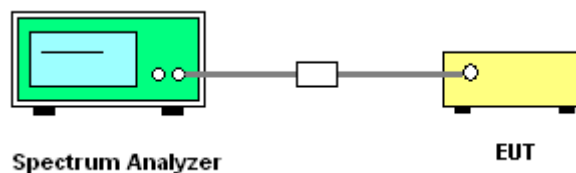



3.1.5 Test Result of 6dB Bandwidth

Test Mode :	Mode 1, 2, 3	Temperature :	23~24°C
Test Engineer :	Eric Hum	Relative Humidity :	40~41%

Channel	Frequency (MHz)	6dB Bandwidth (MHz)	6dB Bandwidth Min. Limit (MHz)	Pass/Fail
01	2412	9.56	0.5	Pass
06	2437	9.96	0.5	Pass
11	2462	9.96	0.5	Pass

Test Mode :	Mode 4, 5, 6	Temperature :	23~24°C
Test Engineer :	Eric Hum	Relative Humidity :	40~41%

Channel	Frequency (MHz)	6dB Bandwidth (MHz)	6dB Bandwidth Min. Limit (MHz)	Pass/Fail
01	2412	16.48	0.5	Pass
06	2437	16.48	0.5	Pass
11	2462	16.52	0.5	Pass



3.1.6 Test Result of 6dB Bandwidth Plots

Mode 1 : 6 dB Bandwidth Plot on 802.11b Channel 01

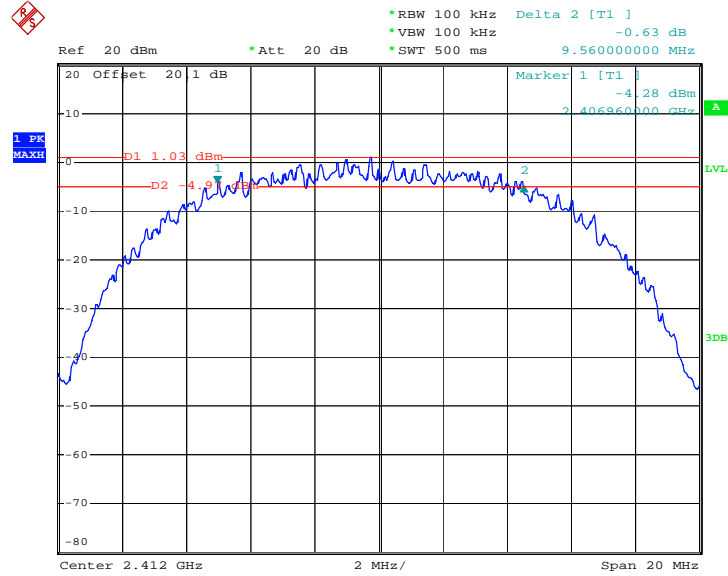

Date: 2.JAN.2009 20:04:12

Mode 2 : 6 dB Bandwidth Plot on 802.11b Channel 06

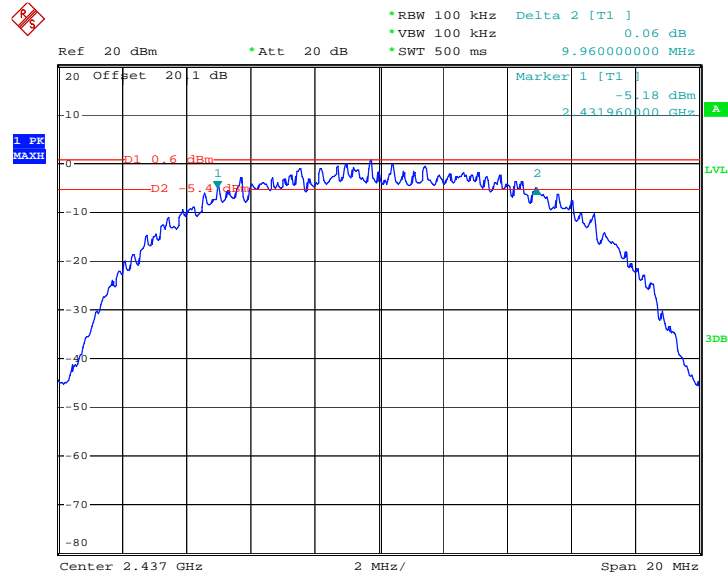

Date: 2.JAN.2009 20:05:34



Mode 3 : 6 dB Bandwidth Plot on 802.11b Channel 11

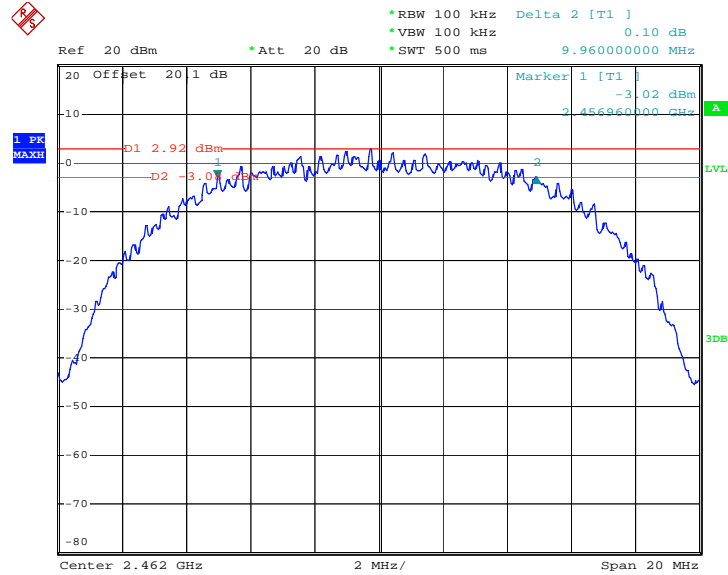

Date: 2.JAN.2009 20:07:03

Mode 4 : 6 dB Bandwidth Plot on 802.11g Channel 01

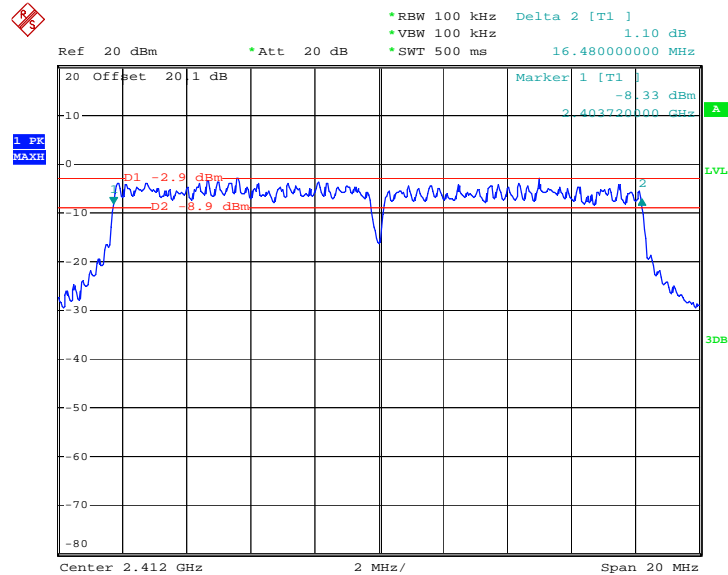

Date: 2.JAN.2009 22:54:39



Mode 5 : 6 dB Bandwidth Plot on 802.11g Channel 06

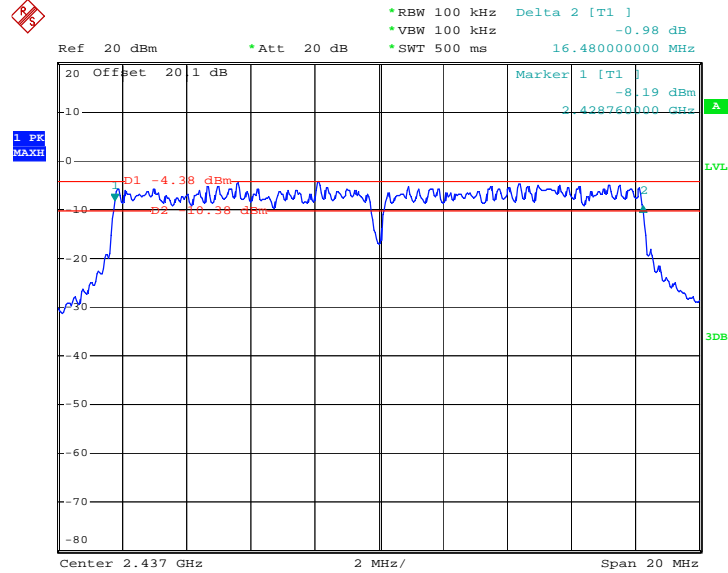

Date: 2.JAN.2009 22:55:34

Mode 6 : 6 dB Bandwidth Plot on 802.11g Channel 11

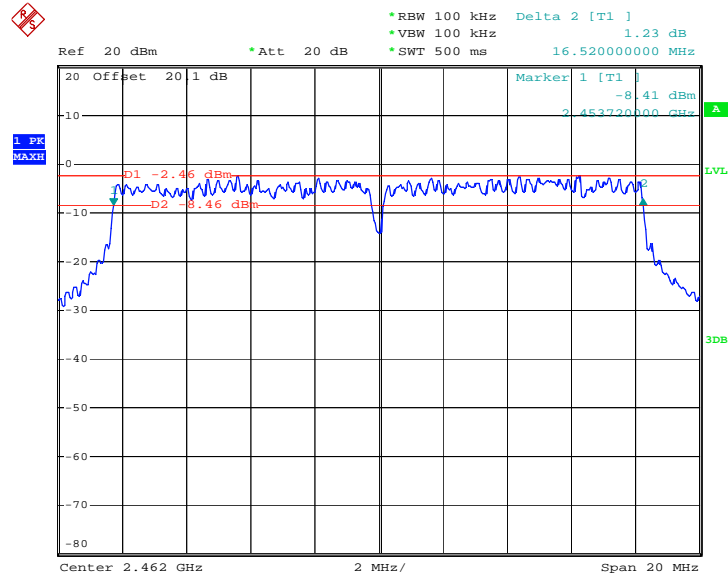

Date: 2.JAN.2009 22:57:05

3.2 Output Power Measurement

3.2.1 Limit of Output Power

For systems using digital modulation in the 2400-2483.5MHz, the limit for peak output power is 30dBm. If transmitting antenna of directional gain greater than 6dBi are used the peak output power from the intentional radiator shall be reduced below the above stated value by the amount in dB that the directional gain of the antenna exceeds 6 dBi. In case of point-to-point operation, the limit has to be reduced by 1dB for every 3dB that the directional gain of the antenna exceeds 6dBi.

3.2.2 Measuring Instruments

See list of measuring instruments of this test report.

3.2.3 Test Procedures

1. The testing follows FCC KDB Publication No. 558074 (Measurement Guidelines of DTS).
2. The RF output of EUT was connected to the spectrum analyzer by a low loss cable.
3. Measure the power by spectrum analyzer.

3.2.4 Test Setup

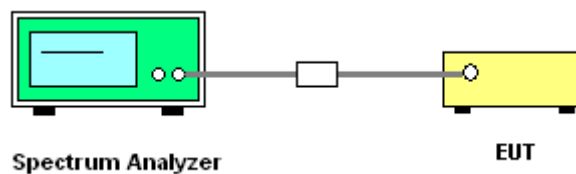



3.2.5 Test Result of Output Power

Test Mode :	Mode 1, 2, 3	Temperature :	23~24°C
Test Engineer :	Eric Hum	Relative Humidity :	40~41%

Channel	Frequency (MHz)	Measured Output Power (dBm)	Max. Limits (dBm)	Pass/Fail
01	2412	12.73	30	Pass
06	2437	12.40	30	Pass
11	2462	14.61	30	Pass

Test Mode :	Mode 4, 5, 6	Temperature :	23~24°C
Test Engineer :	Eric Hum	Relative Humidity :	40~41%

Channel	Frequency (MHz)	Measured Output Power (dBm)	Max. Limits (dBm)	Pass/Fail
01	2412	11.62	30	Pass
06	2437	11.27	30	Pass
11	2462	13.48	30	Pass



3.2.6 Test Result of Output Power Plots

Mode 1 : Output Power Plot on 802.11b Channel 01

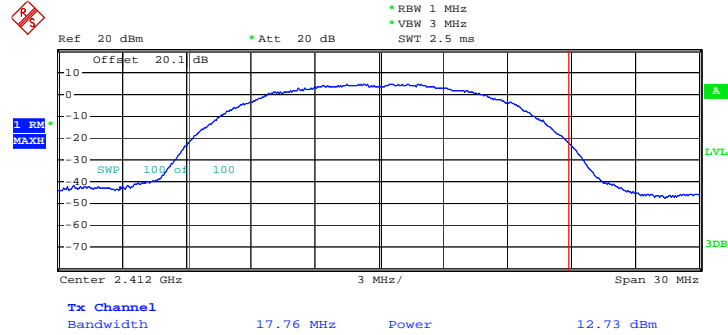

Date: 2.JAN.2009 19:39:01

Mode 2 : Output Power Plot on 802.11b Channel 06

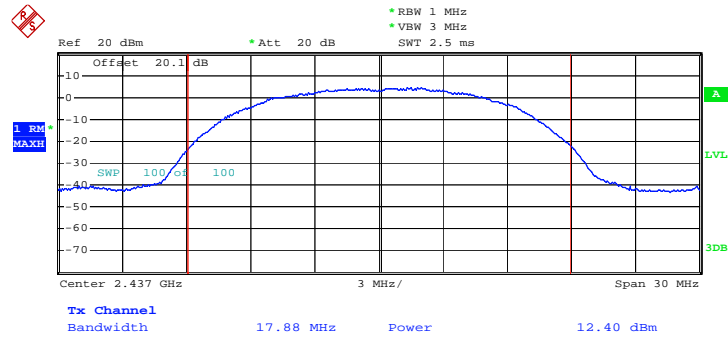

Date: 2.JAN.2009 19:40:40



Mode 3 : Output Power Plot on 802.11b Channel 11

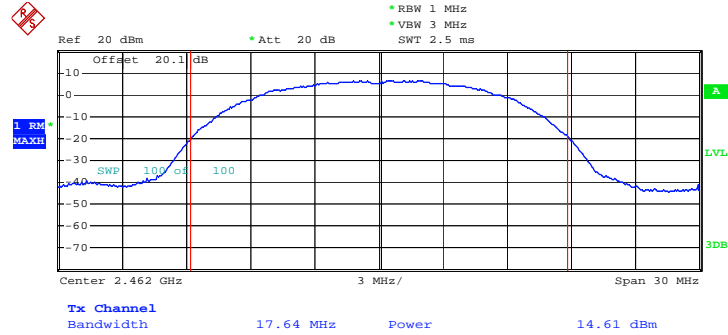

Date: 5.JAN.2009 10:02:19

Mode 4 : Output Power Plot on 802.11g Channel 01

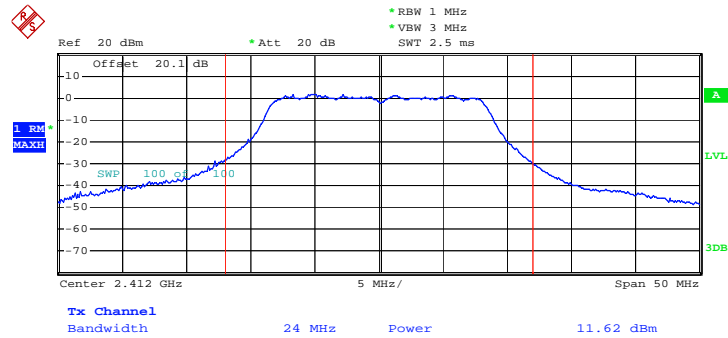

Date: 2.JAN.2009 22:36:33



Mode 5 : Output Power Plot on 802.11g Channel 06

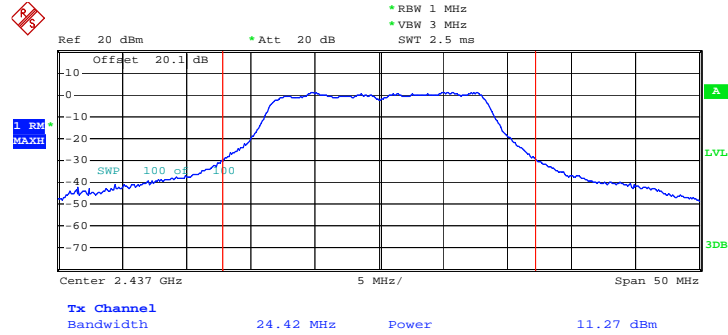

Date: 2.JAN.2009 22:38:40

Mode 6 : Output Power Plot on 802.11g Channel 11

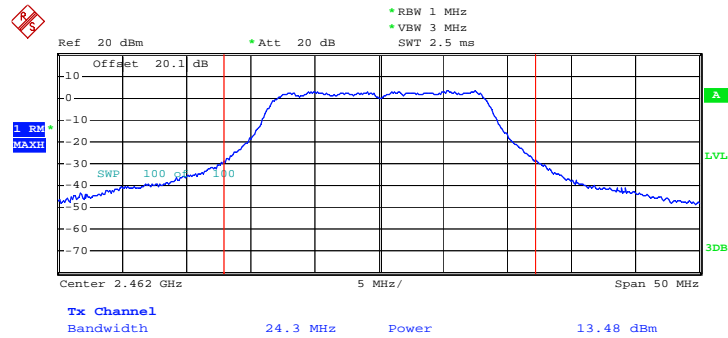

Date: 2.JAN.2009 22:43:04

3.3 Band Edges Measurement

3.3.1 Limit of Band Edges

In any 100 kHz bandwidth outside the intentional radiation frequency band, the radio frequency power shall be at least 20 dB below the highest level of the radiated power. If the output power of this device was measured by spectrum analyzer, the attenuation under this paragraph shall be 30 dB instead of 20 dB.

3.3.2 Measuring Instruments

See list of measuring instruments of this test report.

3.3.3 Test Procedures

1. The testing follows the guidelines in ANSI C63.4-2003 and FCC KDB Publication No. 558074 (Measurement Guidelines of DTS).
2. Conducted emission test: Set RBW = 100 kHz, Video bandwidth (VBW) > RBW, scan up through 10th harmonic. Band edge emissions must be at least 20 dB below the highest emission level within the authorized band as measured with a 100 kHz RBW. Note: If the output power of this device was measured by power meter, the attenuation under this paragraph shall be 30 dB instead of 20 dB.
3. Radiated emission test: Apply to band edge emissions that fall in the restricted bands listed in FCC Section 15.205. The maximum permitted average field strength is listed in FCC Section 15.209. A pre-amp is necessary for this measurement. For measurements above 1 GHz, set RBW = 1MHz, VBW = 10 Hz, Sweep=Auto. If the emission is pulsed, modify the unit for continuous operation; use the settings shown above, then correct the reading by subtracting the peak-average correction factor, derived from the appropriate duty cycle calculation as in FCC Section 15.35(b) and (c).

3.3.4 Test Setup

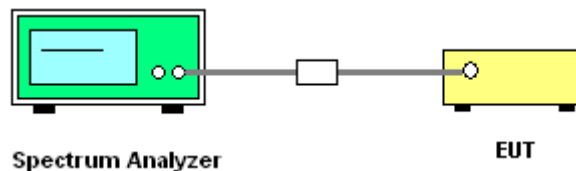



3.3.5 Test Result of Radiated Band Edges

Test Mode :	Mode 1	Temperature :	20~21°C
Test Channel :	01	Relative Humidity :	30~31%
Test Engineer :	Mac Lin		

ANTENNA POLARITY : HORIZONTAL										
Frequency (MHz)	Level (dBuV/m)	Over Limit (dB)	Limit Line (dBuV/m)	Read Level (dBuV)	Antenna Factor (dB)	Cable Loss (dB)	Preamp Factor (dB)	Ant Pos (cm)	Table Pos (deg)	Remark
2387.33	51.13	-22.87	74.00	49.02	32.32	5.46	35.67	100	0	Peak
2387.33	38.55	-15.45	54.00	36.44	32.32	5.46	35.67	100	326	Average

ANTENNA POLARITY : VERTICAL										
Frequency (MHz)	Level (dBuV/m)	Over Limit (dB)	Limit Line (dBuV/m)	Read Level (dBuV)	Antenna Factor (dB)	Cable Loss (dB)	Preamp Factor (dB)	Ant Pos (cm)	Table Pos (deg)	Remark
2372.13	49.49	-24.51	74.00	47.39	32.30	5.47	35.67	100	0	Peak
2372.13	37.35	-16.65	54.00	35.25	32.30	5.47	35.67	190	342	Average

Test Mode :	Mode 3	Temperature :	20~21°C
Test Channel :	11	Relative Humidity :	30~31%
Test Engineer :	Mac Lin		

ANTENNA POLARITY : HORIZONTAL										
Frequency (MHz)	Level (dBuV/m)	Over Limit (dB)	Limit Line (dBuV/m)	Read Level (dBuV)	Antenna Factor (dB)	Cable Loss (dB)	Preamp Factor (dB)	Ant Pos (cm)	Table Pos (deg)	Remark
2483.5	50.47	-23.53	74.00	48.48	32.30	5.38	35.69	100	0	Peak
2483.5	38.88	-15.12	54.00	36.89	32.30	5.38	35.69	100	324	Average

ANTENNA POLARITY : VERTICAL										
Frequency (MHz)	Level (dBuV/m)	Over Limit (dB)	Limit Line (dBuV/m)	Read Level (dBuV)	Antenna Factor (dB)	Cable Loss (dB)	Preamp Factor (dB)	Ant Pos (cm)	Table Pos (deg)	Remark
2483.5	50.07	-23.93	74.00	48.08	32.30	5.38	35.69	100	0	Peak
2483.5	38.49	-15.51	54.00	36.50	32.30	5.38	35.69	131	335	Average



Test Mode :	Mode 4	Temperature :	20~21°C
Test Channel :	01	Relative Humidity :	30~31%
Test Engineer :	Mac Lin		

ANTENNA POLARITY : HORIZONTAL										
Frequency (MHz)	Level (dBuV/m)	Over Limit (dB)	Limit Line (dBuV/m)	Read Level (dBuV)	Antenna Factor (dB)	Cable Loss (dB)	Preamp Factor (dB)	Ant Pos (cm)	Table Pos (deg)	Remark
2389.99	58.36	-15.64	74.00	56.26	32.32	5.46	35.68	100	0	Peak
2389.99	44.64	-9.36	54.00	42.54	32.32	5.46	35.68	102	325	Average

ANTENNA POLARITY : VERTICAL										
Frequency (MHz)	Level (dBuV/m)	Over Limit (dB)	Limit Line (dBuV/m)	Read Level (dBuV)	Antenna Factor (dB)	Cable Loss (dB)	Preamp Factor (dB)	Ant Pos (cm)	Table Pos (deg)	Remark
2389.99	58.26	-15.74	74.00	56.18	32.30	5.46	35.68	100	0	Peak
2389.99	43.66	-10.34	54.00	41.58	32.30	5.46	35.68	194	342	Average

Test Mode :	Mode 6	Temperature :	20~21°C
Test Channel :	11	Relative Humidity :	30~31%
Test Engineer :	Mac Lin		

ANTENNA POLARITY : HORIZONTAL										
Frequency (MHz)	Level (dBuV/m)	Over Limit (dB)	Limit Line (dBuV/m)	Read Level (dBuV)	Antenna Factor (dB)	Cable Loss (dB)	Preamp Factor (dB)	Ant Pos (cm)	Table Pos (deg)	Remark
2483.5	58.88	-15.12	74.00	56.89	32.30	5.38	35.69	100	0	Peak
2483.5	41.89	-12.11	54.00	39.90	32.30	5.38	35.69	100	303	Average

ANTENNA POLARITY : VERTICAL										
Frequency (MHz)	Level (dBuV/m)	Over Limit (dB)	Limit Line (dBuV/m)	Read Level (dBuV)	Antenna Factor (dB)	Cable Loss (dB)	Preamp Factor (dB)	Ant Pos (cm)	Table Pos (deg)	Remark
2483.5	59.28	-14.72	74.00	57.29	32.30	5.38	35.69	100	0	Peak
2483.5	41.94	-12.06	54.00	39.95	32.30	5.38	35.69	104	348	Average



3.3.6 Test Result of Conducted Band Edges

Test Mode :	Mode 1 and 3	Temperature :	23~24°C
Test Channel :	01, 11	Relative Humidity :	40~41%
Test Engineer :	Eric Hum		

Low Band Edge Plot on 802.11b Channel 01

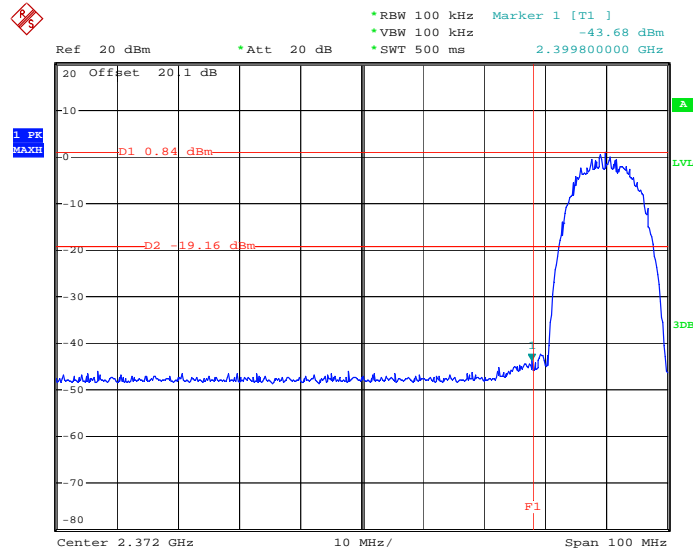

Date: 2.JAN.2009 20:31:07

High Band Edge Plot on 802.11b Channel 11

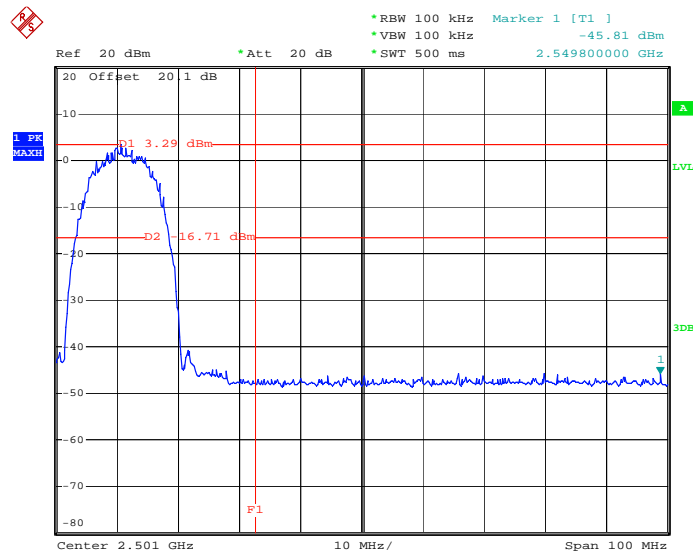

Date: 2.JAN.2009 20:32:52



Test Mode :	Mode 4 and 6	Temperature :	23~24°C
Test Channel :	01, 11	Relative Humidity :	40~41%
Test Engineer :	Eric Hum		

Low Band Edge Plot on 802.11g Channel 01

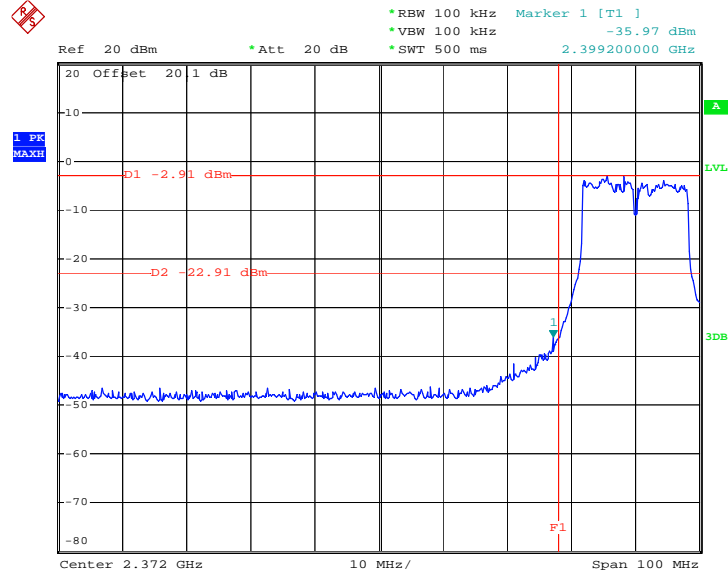

Date: 2.JAN.2009 22:59:02

High Band Edge Plot on 802.11g Channel 11

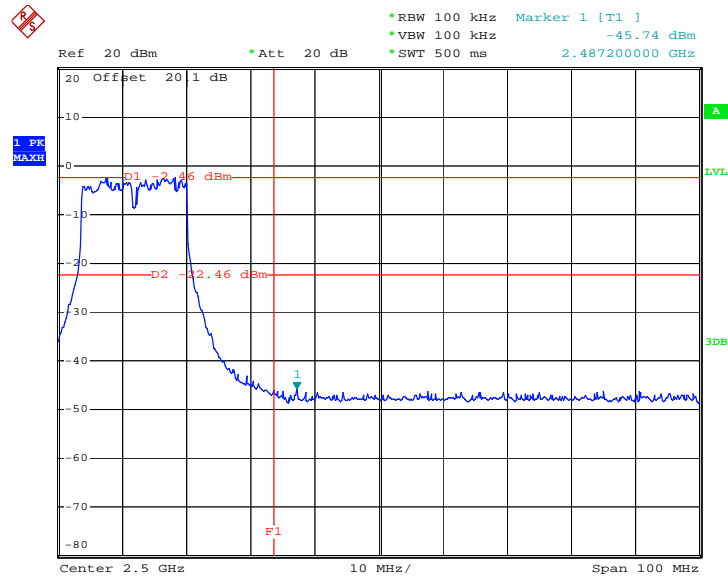

Date: 2.JAN.2009 22:58:20

3.4 Power Spectral Density Measurement

3.4.1 Limit of Power Spectral Density

The peak power spectral density shall not be greater than 8dBm in any 3kHz band at any time interval of continuous transmission.

3.4.2 Measuring Instruments

See list of measuring instruments of this test report.

3.4.3 Test Procedures

1. The test follows FCC KDB Publication No. 558074 (Measurement Guidelines of DTS).
2. The RF output of EUT was connected to the spectrum analyzer by a low loss cable.
3. Take the measured data from spectrum analyzer.

3.4.4 Test Setup

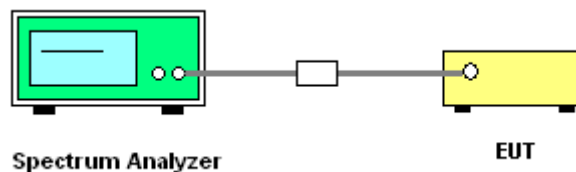



3.4.5 Test Result of Power Spectral Density

Test Mode :	Mode 1, 2, 3	Temperature :	23~24°C
Test Engineer :	Eric Hum	Relative Humidity :	40~41%

Channel	Frequency (MHz)	Measured PSD (dBm)	Max. Limits (dBm)	Pass/Fail
01	2412	-13.00	8	Pass
06	2437	-13.52	8	Pass
11	2462	-10.81	8	Pass

Test Mode :	Mode 4, 5, 6	Temperature :	23~24°C
Test Engineer :	Eric Hum	Relative Humidity :	40~41%

Channel	Frequency (MHz)	Measured PSD (dBm)	Max. Limits (dBm)	Pass/Fail
01	2412	-19.02	8	Pass
06	2437	-18.61	8	Pass
11	2462	-17.11	8	Pass



3.4.6 Test Result of Power Spectral Density Plots

Mode 1 : PSD Plot on 802.11b Channel 01

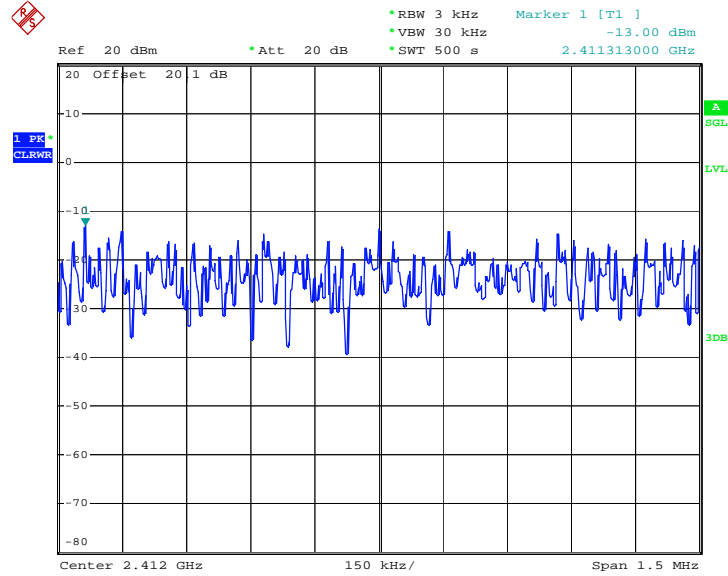

Date: 2.JAN.2009 20:28:58

Mode 2 : PSD Plot on 802.11b Channel 06

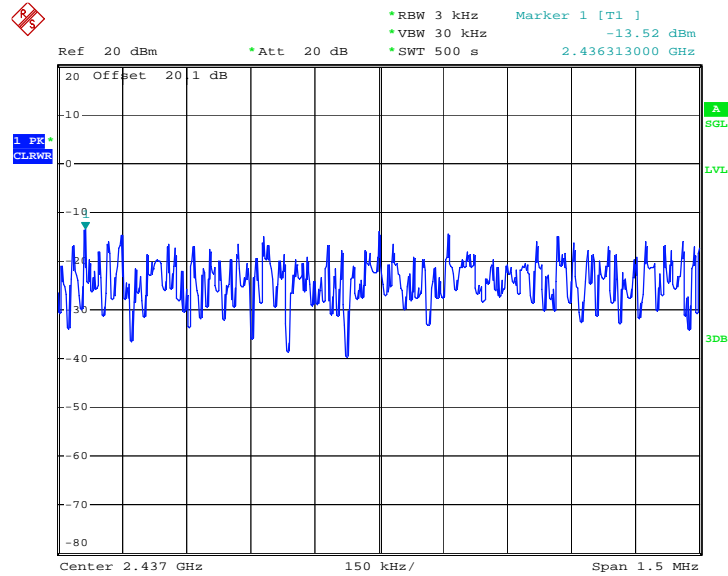

Date: 2.JAN.2009 20:53:26



Mode 3 : PSD Plot on 802.11b Channel 11

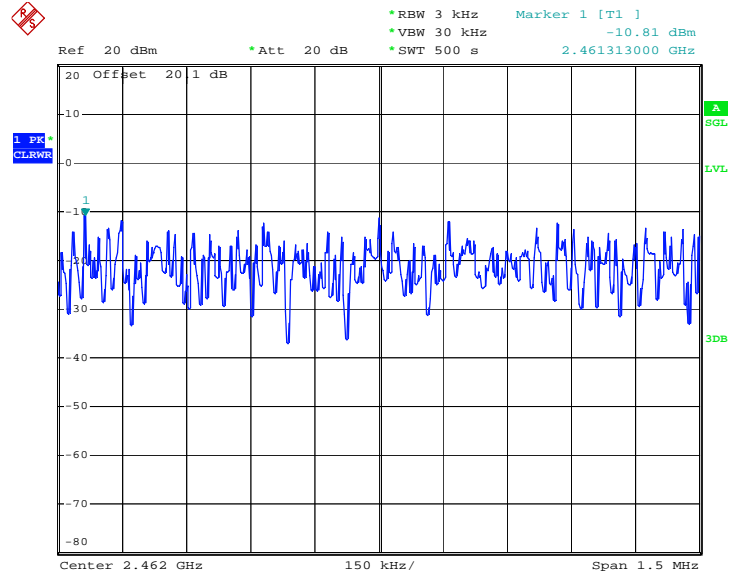

Date: 2.JAN.2009 21:16:07

Mode 4 : PSD Plot on 802.11g Channel 01

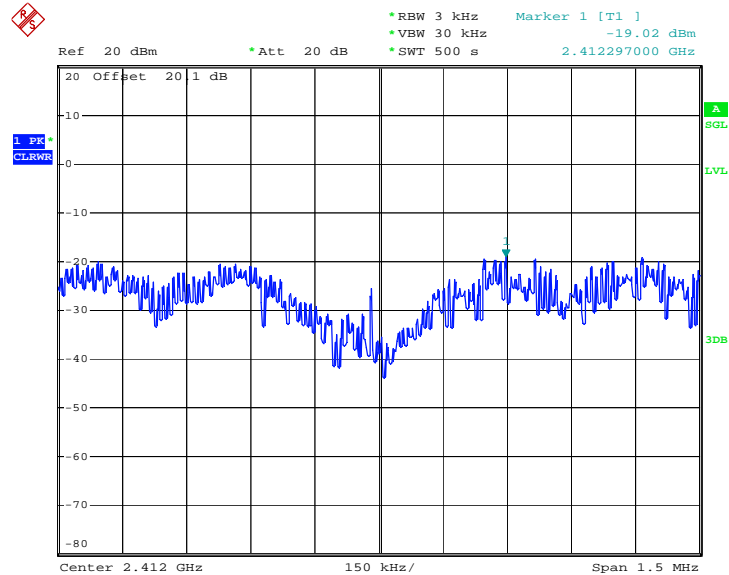

Date: 2.JAN.2009 23:41:36



Mode 5 : PSD Plot on 802.11g Channel 06

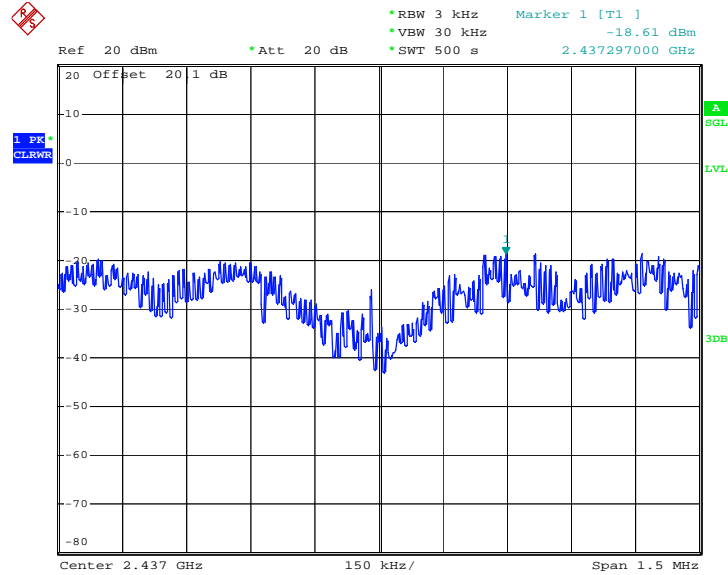

Date: 2.JAN.2009 23:32:36

Mode 6 : PSD Plot on 802.11g Channel 11

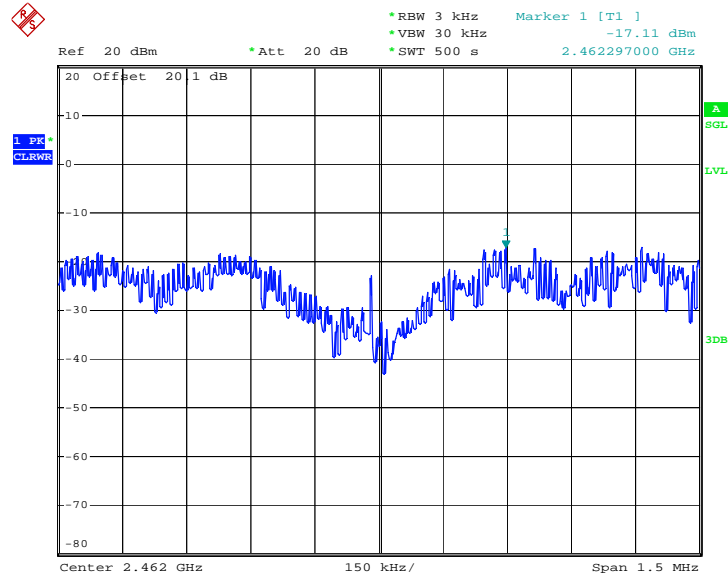

Date: 2.JAN.2009 23:18:37

3.5 AC Conducted Emission Measurement

3.5.1 Limit of AC Conducted Emission

For equipment that is designed to be connected to the public utility (AC) power line, the radio frequency voltage that is conducted back onto the AC power line on any frequency or frequencies within the band 150 kHz to 30 MHz shall not exceed the limits in the following table.

Frequency of emission (MHz)	Conducted limit (dBuV)	
	Quasi-peak	Average
0.15-0.5	66 to 56*	56 to 46*
0.5-5	56	46
5-30	60	50

*Decreases with the logarithm of the frequency.

3.5.2 Measuring Instruments

See list of measuring instruments of this test report.

3.5.3 Test Procedures

1. The testing follows the guidelines in ANSI C63.4-2003.
2. The EUT was placed 0.4 meter from the conducting wall of the shielding room, and it was kept at least 80 centimeters from any other grounded conducting surface.
3. Connect EUT to the power mains through a line impedance stabilization network (LISN).
4. All the support units are connecting to the other LISN.
5. The LISN provides 50 ohm coupling impedance for the measuring instrument.
6. The FCC states that a 50 ohm, 50 microhenry LISN should be used.
7. Both sides of AC line were checked for maximum conducted interference.
8. The frequency range from 150 kHz to 30 MHz was searched.
9. Set the test-receiver system to Peak Detect Function and specified bandwidth with Maximum Hold Mode.

3.5.4 Test Setup

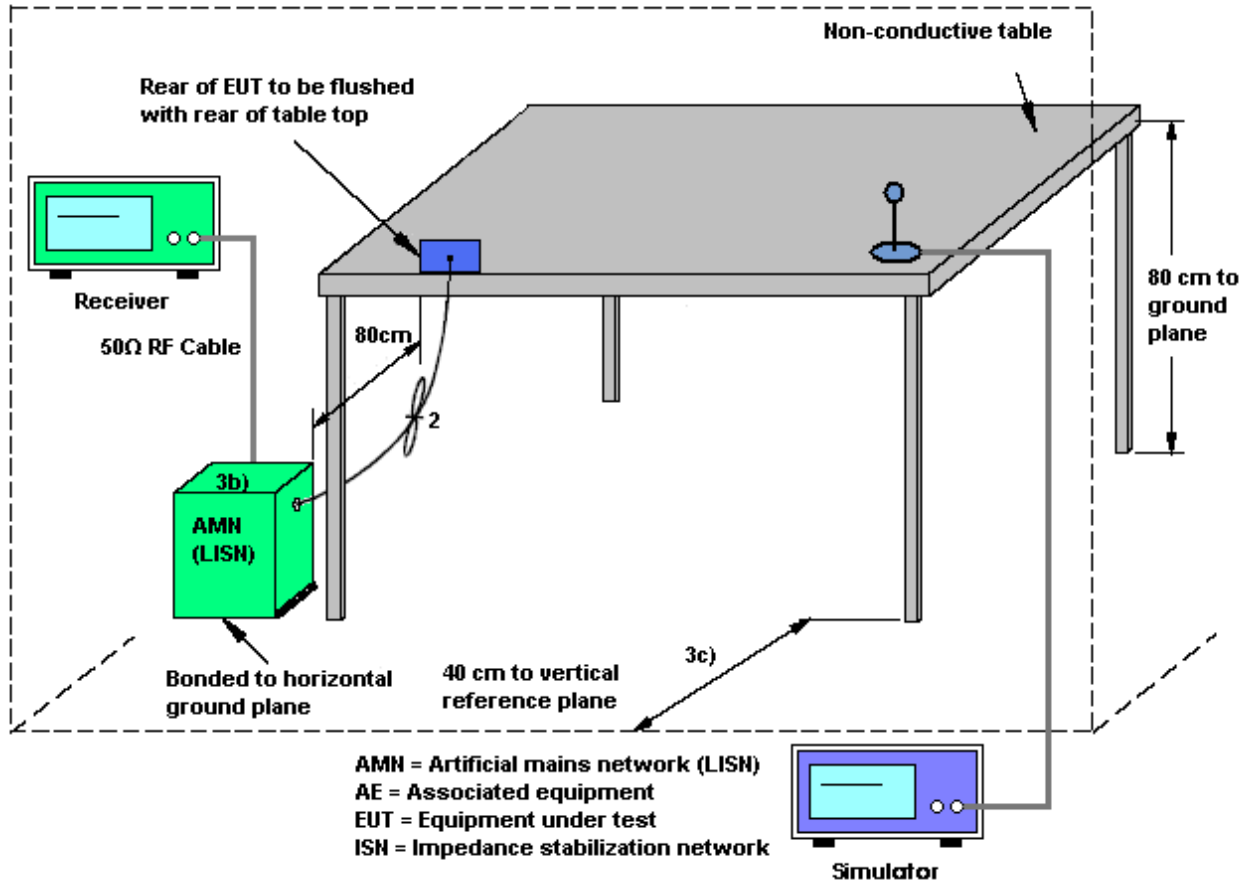

3.5.5 Test Result of AC Conducted Emission

Test Mode :	Mode 1	Temperature :	23~24°C
Test Engineer :	Cona Huang	Relative Humidity :	40~41%
		Phase :	Line
Function Type :	GSM 850 Idle + GPS Rx + BT Link + WLAN Link + Earphone + Cradle + Adapter + USB Cable		
Remark :	All emissions not reported here are more than 10 dB below the prescribed limit.		

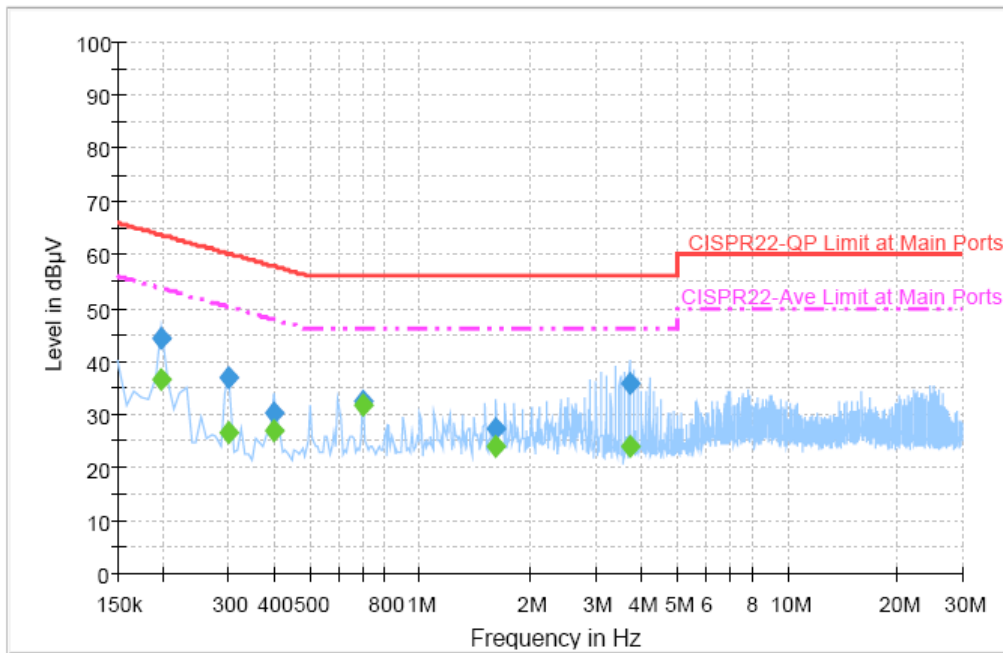

Final Result 1

Frequency (MHz)	QuasiPeak (dBµV)	Filter	Line	Corr. (dB)	Margin (dB)	Limit (dBµV)
0.198000	44.3	Off	L1	19.3	19.4	63.7
0.302000	37.0	Off	L1	19.3	23.2	60.2
0.398000	30.3	Off	L1	19.4	27.6	57.9
0.702000	32.6	Off	L1	19.5	23.4	56.0
1.606000	27.2	Off	L1	19.4	28.8	56.0
3.710000	35.7	Off	L1	19.5	20.3	56.0

Final Result 2

Frequency (MHz)	Average (dBµV)	Filter	Line	Corr. (dB)	Margin (dB)	Limit (dBµV)
0.198000	36.6	Off	L1	19.3	17.1	53.7
0.302000	26.5	Off	L1	19.3	23.8	50.2
0.398000	26.8	Off	L1	19.4	21.1	47.9
0.702000	31.7	Off	L1	19.5	14.3	46.0
1.606000	24.0	Off	L1	19.4	22.0	46.0
3.710000	23.9	Off	L1	19.5	22.1	46.0

Test Mode :	Mode 1	Temperature :	23~24°C
Test Engineer :	Cona Huang	Relative Humidity :	40~41%
		Phase :	Neutral
Function Type :	GSM 850 Idle + GPS Rx + BT Link + WLAN Link + Earphone + Cradle + Adapter + USB Cable		
Remark :	All emissions not reported here are more than 10 dB below the prescribed limit.		

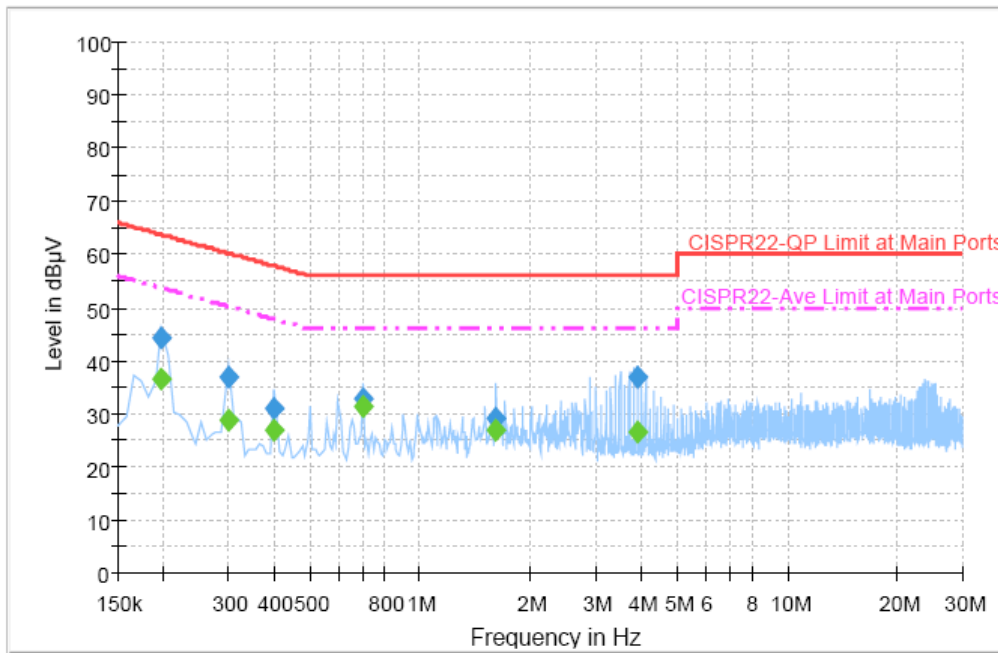

Final Result 1

Frequency (MHz)	QuasiPeak (dBµV)	Filter	Line	Corr. (dB)	Margin (dB)	Limit (dBµV)
0.198000	44.2	Off	N	19.3	19.5	63.7
0.302000	37.0	Off	N	19.3	23.2	60.2
0.398000	31.0	Off	N	19.4	26.9	57.9
0.702000	32.9	Off	N	19.5	23.1	56.0
1.606000	29.2	Off	N	19.4	26.8	56.0
3.910000	36.9	Off	N	19.5	19.1	56.0

Final Result 2

Frequency (MHz)	Average (dBµV)	Filter	Line	Corr. (dB)	Margin (dB)	Limit (dBµV)
0.198000	36.7	Off	N	19.3	17.0	53.7
0.302000	28.8	Off	N	19.3	21.4	50.2
0.398000	26.9	Off	N	19.4	21.0	47.9
0.702000	31.5	Off	N	19.5	14.5	46.0
1.606000	26.9	Off	N	19.4	19.1	46.0
3.910000	26.6	Off	N	19.5	19.4	46.0

Test Mode :	Mode 2	Temperature :	23~24°C
Test Engineer :	Cona Huang	Relative Humidity :	40~41%
		Phase :	Line
Function Type :	GSM 850 Idle + GPS Rx + BT Link + WLAN Link + Earphone + USB Charging Cable with AC Power		
Remark :	All emissions not reported here are more than 10 dB below the prescribed limit.		

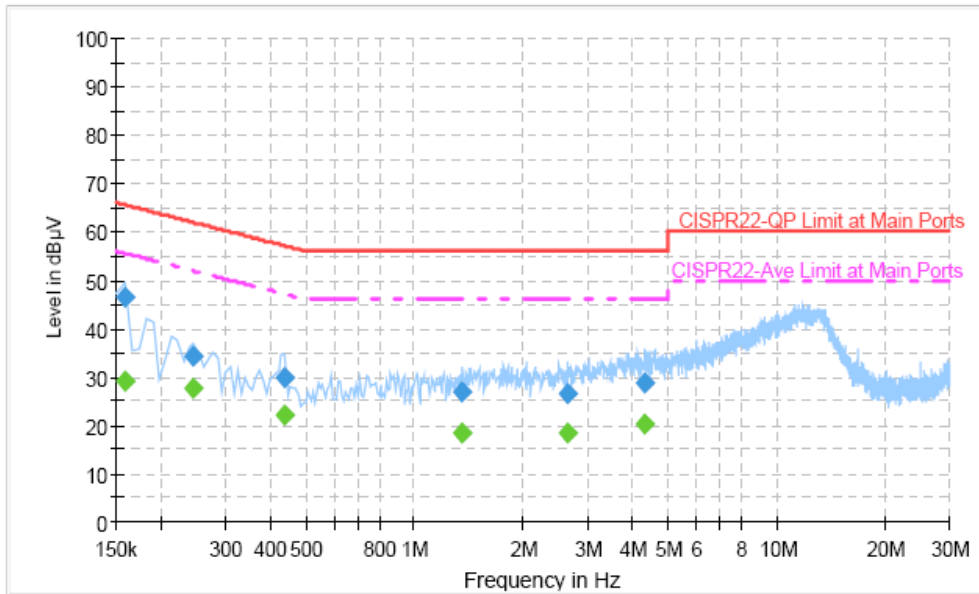

Final Result 1

Frequency (MHz)	QuasiPeak (dBµV)	Filter	Line	Corr. (dB)	Margin (dB)	Limit (dBµV)
0.158000	46.6	Off	L1	19.3	19.0	65.6
0.246000	34.4	Off	L1	19.4	27.5	61.9
0.438000	30.0	Off	L1	19.4	27.1	57.1
1.358000	27.0	Off	L1	19.4	29.0	56.0
2.646000	26.5	Off	L1	19.4	29.5	56.0
4.326000	28.9	Off	L1	19.5	27.1	56.0

Final Result 2

Frequency (MHz)	Average (dBµV)	Filter	Line	Corr. (dB)	Margin (dB)	Limit (dBµV)
0.158000	29.3	Off	L1	19.3	26.3	55.6
0.246000	27.5	Off	L1	19.4	24.4	51.9
0.438000	22.0	Off	L1	19.4	25.1	47.1
1.358000	18.3	Off	L1	19.4	27.7	46.0
2.646000	18.5	Off	L1	19.4	27.5	46.0
4.326000	20.4	Off	L1	19.5	25.6	46.0

Test Mode :	Mode 2	Temperature :	23~24°C
Test Engineer :	Cona Huang	Relative Humidity :	40~41%
		Phase :	Neutral
Function Type :	GSM 850 Idle + GPS Rx + BT Link + WLAN Link + Earphone + USB Charging Cable with AC Power		
Remark :	All emissions not reported here are more than 10 dB below the prescribed limit.		

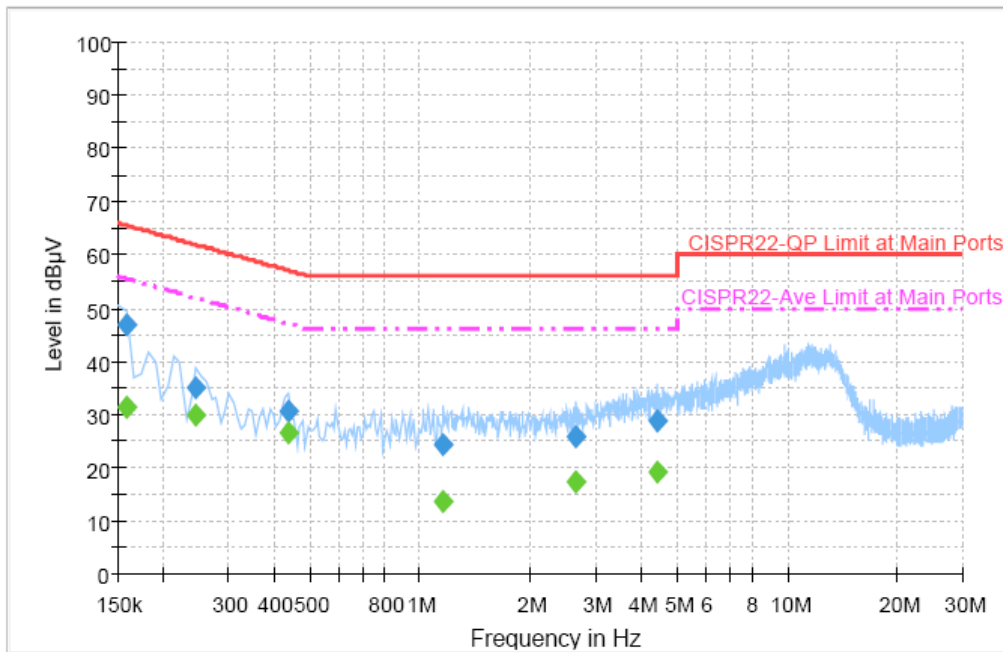

Final Result 1

Frequency (MHz)	QuasiPeak (dBµV)	Filter	Line	Corr. (dB)	Margin (dB)	Limit (dBµV)
0.158000	46.9	Off	N	19.4	18.7	65.6
0.246000	35.1	Off	N	19.4	26.8	61.9
0.438000	30.7	Off	N	19.4	26.4	57.1
1.158000	24.2	Off	N	19.4	31.8	56.0
2.662000	25.9	Off	N	19.4	30.1	56.0
4.438000	28.6	Off	N	19.5	27.4	56.0

Final Result 2

Frequency (MHz)	Average (dBµV)	Filter	Line	Corr. (dB)	Margin (dB)	Limit (dBµV)
0.158000	31.5	Off	N	19.4	24.1	55.6
0.246000	29.9	Off	N	19.4	22.0	51.9
0.438000	26.7	Off	N	19.4	20.4	47.1
1.158000	13.7	Off	N	19.4	32.3	46.0
2.662000	17.3	Off	N	19.4	28.7	46.0
4.438000	19.1	Off	N	19.5	26.9	46.0

Test Mode :	Mode 3	Temperature :	23~24°C
Test Engineer :	Cona Huang	Relative Humidity :	40~41%
		Phase :	Line
Function Type :	WCDMA Idle + GPS Rx + BT Link + WLAN Link + Earphone + Cradle + Adapter + USB Cable		
Remark :	All emissions not reported here are more than 10 dB below the prescribed limit.		

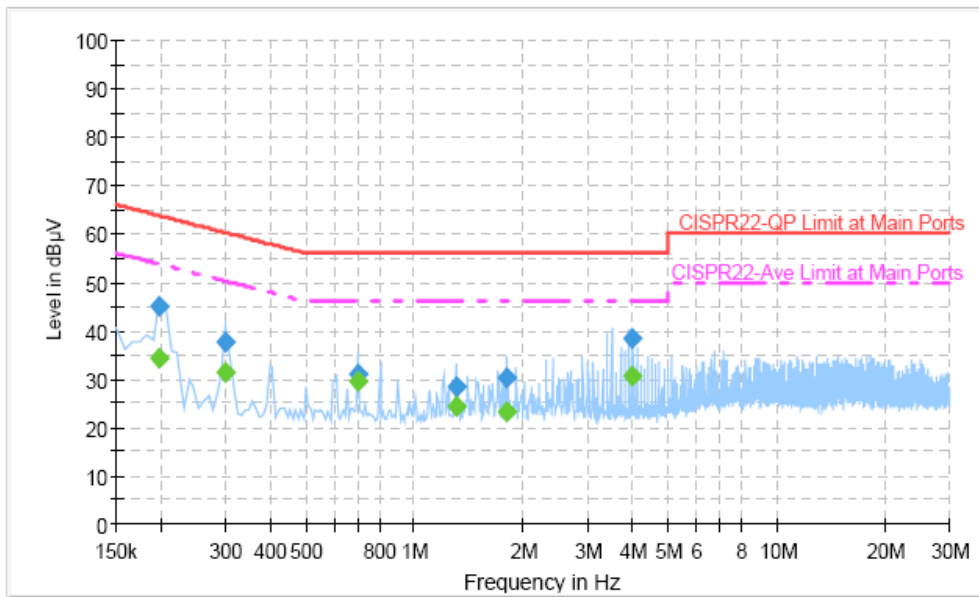

Final Result 1

Frequency (MHz)	QuasiPeak (dBµV)	Filter	Line	Corr. (dB)	Margin (dB)	Limit (dBµV)
0.198000	45.2	Off	L1	19.3	18.5	63.7
0.302000	37.8	Off	L1	19.3	22.4	60.2
0.702000	31.0	Off	L1	19.5	25.0	56.0
1.302000	28.4	Off	L1	19.5	27.6	56.0
1.806000	30.4	Off	L1	19.5	25.6	56.0
4.014000	38.3	Off	L1	19.5	17.7	56.0

Final Result 2

Frequency (MHz)	Average (dBµV)	Filter	Line	Corr. (dB)	Margin (dB)	Limit (dBµV)
0.198000	34.4	Off	L1	19.3	19.3	53.7
0.302000	31.2	Off	L1	19.3	19.0	50.2
0.702000	29.6	Off	L1	19.5	16.4	46.0
1.302000	24.2	Off	L1	19.5	21.8	46.0
1.806000	23.2	Off	L1	19.5	22.8	46.0
4.014000	30.5	Off	L1	19.5	15.5	46.0

Test Mode :	Mode 3	Temperature :	23~24°C
Test Engineer :	Cona Huang	Relative Humidity :	40~41%
		Phase :	Neutral
Function Type :	WCDMA Idle + GPS Rx + BT Link + WLAN Link + Earphone + Cradle + Adapter + USB Cable		
Remark :	All emissions not reported here are more than 10 dB below the prescribed limit.		

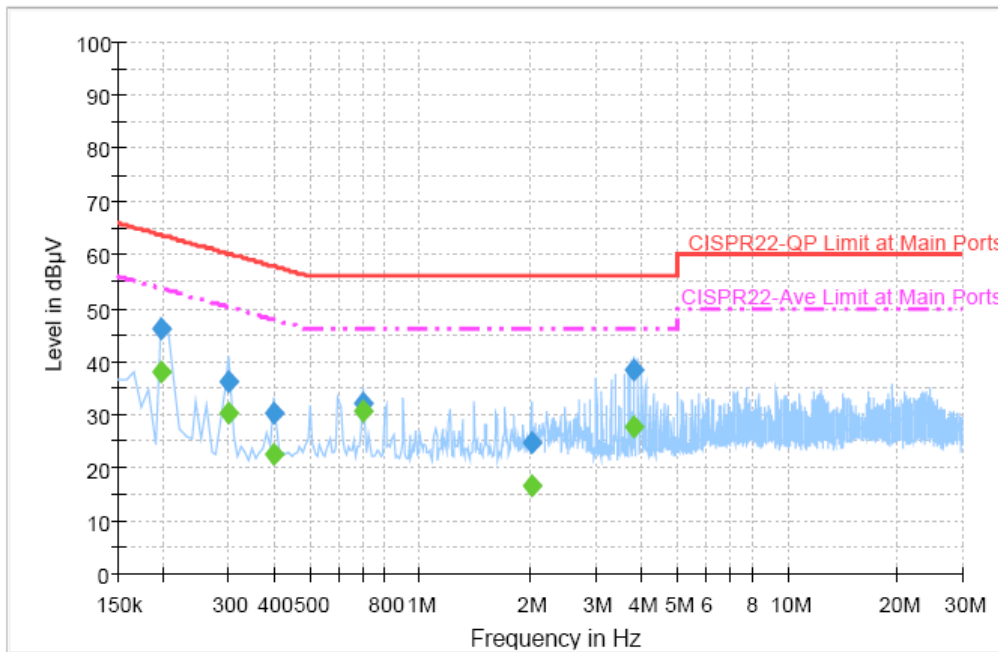

Final Result 1

Frequency (MHz)	QuasiPeak (dBµV)	Filter	Line	Corr. (dB)	Margin (dB)	Limit (dBµV)
0.198000	46.1	Off	N	19.3	17.6	63.7
0.302000	36.1	Off	N	19.3	24.1	60.2
0.398000	30.4	Off	N	19.4	27.5	57.9
0.702000	32.0	Off	N	19.5	24.0	56.0
2.006000	24.6	Off	N	19.5	31.4	56.0
3.814000	38.4	Off	N	19.5	17.6	56.0

Final Result 2

Frequency (MHz)	Average (dBµV)	Filter	Line	Corr. (dB)	Margin (dB)	Limit (dBµV)
0.198000	38.0	Off	N	19.3	15.7	53.7
0.302000	30.3	Off	N	19.3	19.9	50.2
0.398000	22.5	Off	N	19.4	25.4	47.9
0.702000	30.6	Off	N	19.5	15.4	46.0
2.006000	16.5	Off	N	19.5	29.5	46.0
3.814000	27.6	Off	N	19.5	18.4	46.0

3.6 Radiated Emission Measurement

3.6.1 Limit of Radiated Emission

In any 100 kHz bandwidth outside the intentional radiator frequency band, all harmonics/spurious must be at least 20 dB below the highest emission level within the authorized band. If the output power of this device was measured by spectrum analyzer, the attenuation under this paragraph shall be 30 dB instead of 20 dB. In addition, radiated emissions which fall in the restricted bands must also comply with the FCC section 15.209 limits as below.

Frequency (MHz)	Field Strength (microvolts/meter)	Measurement Distance (meters)
0.009 – 0.490	2400/F(kHz)	300
0.490 – 1.705	24000/F(kHz)	30
1.705 – 30.0	30	30
30 – 88	100	3
88 – 216	150	3
216 - 960	200	3
Above 960	500	3

3.6.2 Measuring Instruments

See list of measuring instruments of this test report.

3.6.3 Test Procedures

1. The testing follows the guidelines in FCC KDB Publication No. 558074 (Measurement Guidelines of DTS).
2. Use the following spectrum analyzer settings:
Span = wide enough to fully capture the emission being measured; RBW = 1 MHz for $f \geq 1$ GHz, 100 kHz for $f < 1$ GHz; VBW \geq RBW; Sweep = auto; Detector function = peak; Trace = max hold.
3. Follow the guidelines in ANSI C63.4-2003 with respect to maximizing the emission by rotating the EUT, measuring the emission for three EUT orthogonal planes, and adjusting the measurement antenna height and polarization. A pre-amp and a high pass filter are used for this test in order to get the good signal level.

3.6.4 Test Setup

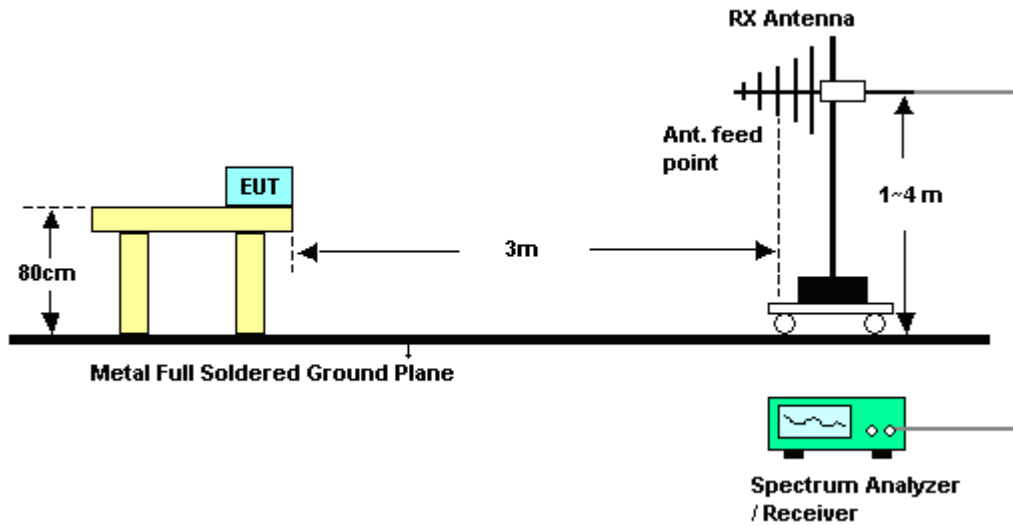



3.6.5 Test Result of Radiated Emission < 1GHz

Test Mode :	Mode 1	Temperature :	20~21°C
Test Channel :	01	Relative Humidity :	30~31%
Test Engineer :	Mac Lin	Polarization :	Horizontal
Remark :			

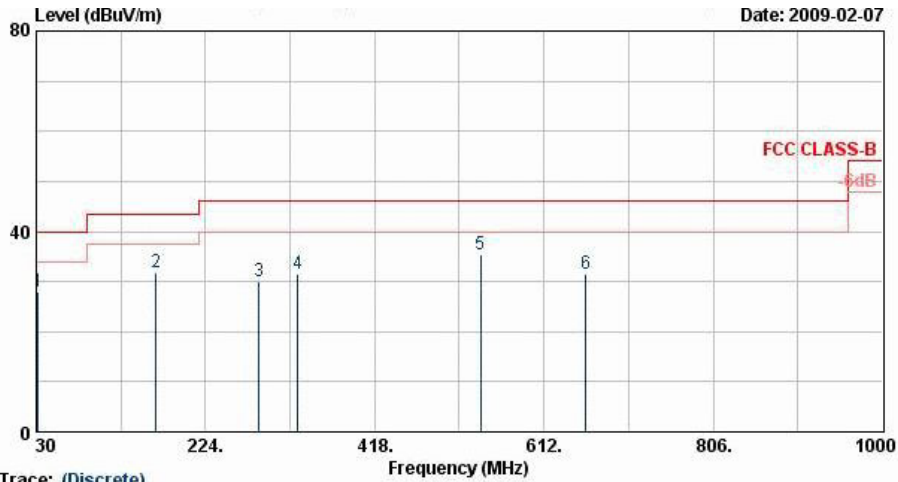

Trace: (Discrete)
 Site : 03CH07-HY
 Condition : FCC CLASS-B 3m BILOG_081118 HORIZONTAL
 Project : FR 803027-02

	Freq	Level	Over Limit	Limit Line	ReadAntenna Level	Antenna Factor	Cable Loss	Preamp Factor	Ant Pos	Table Pos	Remark
	MHz	dBuV/m	dB	dBuV/m	dBuV	dB/m	dB	dB	cm	deg	
1	31.89	28.05	-11.95	40.00	40.83	17.82	0.66	31.26	---	---	Peak
2	166.89	31.85	-11.65	43.50	51.91	9.72	1.54	31.32	---	---	Peak
3	285.69	29.90	-16.10	46.00	46.21	13.08	2.06	31.44	---	---	Peak
4	329.40	31.60	-14.40	46.00	46.87	13.84	2.26	31.37	---	---	Peak
5 @	539.40	35.29	-10.71	46.00	45.39	17.89	3.06	31.05	100	14	Peak
6	659.80	31.43	-14.57	46.00	39.90	18.99	3.44	30.90	---	---	Peak



Test Mode :	Mode 1	Temperature :	20~21°C
Test Channel :	01	Relative Humidity :	30~31%
Test Engineer :	Mac Lin	Polarization :	Vertical
Remark :			

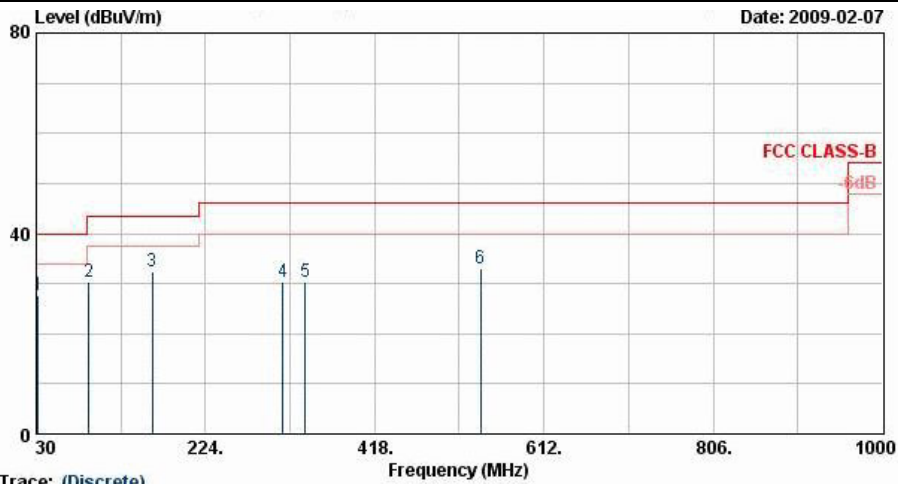

Site : 03CH07-HY
 Condition : FCC CLASS-B 3m BILOG_081118 VERTICAL
 Project : FR 803027-02

	Freq	Level	Over	Limit	ReadAntenna	Cable	Preamp	Ant	Table	Remark	
	MHz	dBuV/m	dB	dBuV/m	dBuV	dB/m	dB	dB	cm	deg	
1	31.89	27.80	-12.20	40.00	40.58	17.82	0.66	31.26	---	---	Peak
2	89.94	30.34	-13.16	43.50	51.53	9.13	1.11	31.43	---	---	Peak
3	163.38	32.36	-11.14	43.50	52.30	9.85	1.53	31.32	100	332	QP
4	312.60	30.20	-15.80	46.00	46.01	13.39	2.19	31.38	---	---	Peak
5	338.50	30.36	-15.64	46.00	45.41	14.07	2.29	31.41	---	---	Peak
6	539.40	33.01	-12.99	46.00	43.11	17.89	3.06	31.05	---	---	Peak



Test Mode :	Mode 2	Temperature :	20~21°C
Test Channel :	06	Relative Humidity :	30~31%
Test Engineer :	Mac Lin	Polarization :	Horizontal
Remark :			

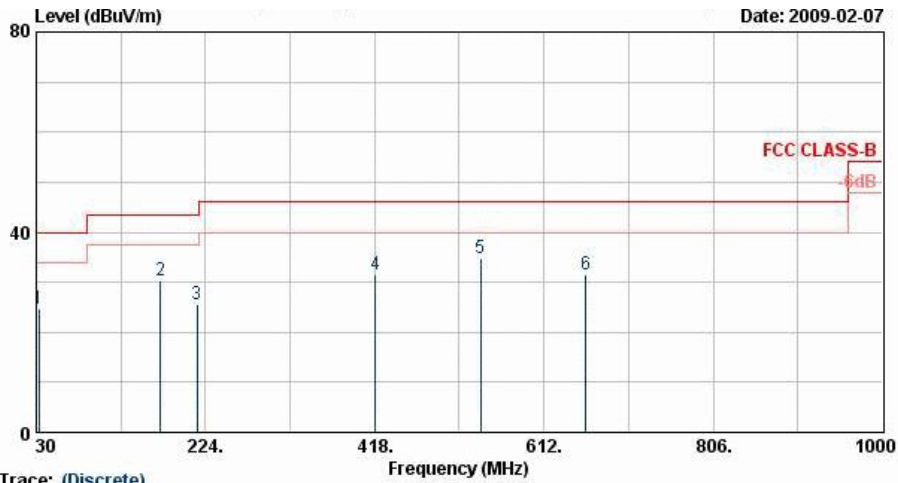

Trace: (Discrete)
 Site : 03CH07-HY
 Condition : FCC CLASS-B 3m BILOG_081118 HORIZONTAL
 Project : FR 803027-02

	Freq	Level	Over	Limit	Read	Antenna	Cable	Preamp	Ant	Table	Remark
	MHz	dBuV/m	dB	dBuV/m	dBuV	dB/m	dB	dB	cm	deg	
1	32.97	24.58	-15.42	40.00	38.03	17.12	0.66	31.23	---	---	Peak
2	172.29	30.36	-13.14	43.50	50.68	9.46	1.56	31.34	---	---	Peak
3	214.41	25.58	-17.92	43.50	45.11	10.12	1.77	31.42	---	---	Peak
4	419.00	31.38	-14.62	46.00	44.03	15.98	2.66	31.30	---	---	Peak
5 @	539.40	34.85	-11.15	46.00	44.94	17.89	3.06	31.05	100	27	Peak
6	659.80	31.39	-14.61	46.00	39.86	18.99	3.44	30.90	---	---	Peak



Test Mode :	Mode 2	Temperature :	20~21°C
Test Channel :	06	Relative Humidity :	30~31%
Test Engineer :	Mac Lin	Polarization :	Vertical
Remark :			

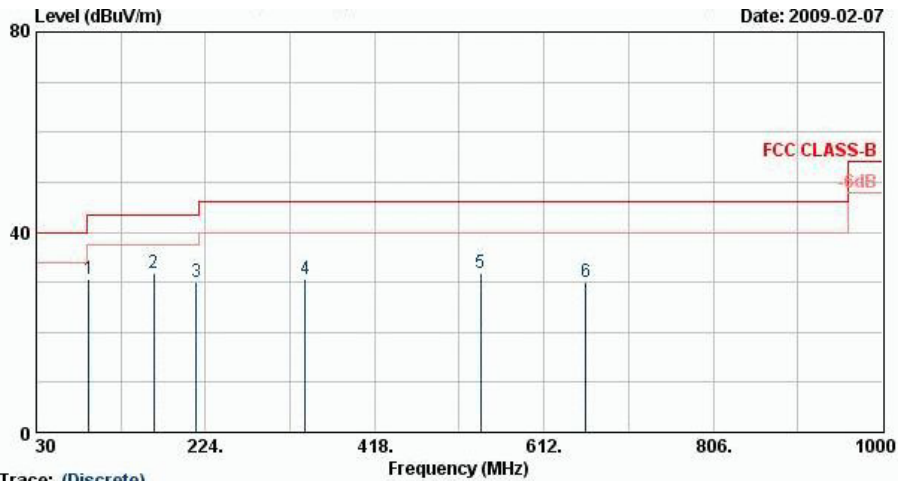

Trace: (Discrete)
 Site : 03CH07-HY
 Condition : FCC CLASS-B 3m BILOG_081118 VERTICAL
 Project : FR 803027-02

	Freq	Level	Over Limit	Limit Line	ReadAntenna Level	Cable Loss	Preamp Factor	Ant Pos	Table Pos	Remark
	MHz	dBuV/m	dB	dBuV/m	dBuV	dB/m	dB	cm	deg	
1	90.21	30.69	-12.81	43.50	51.88	9.13	1.11	31.43	---	Peak
2	164.73	31.92	-11.58	43.50	51.90	9.81	1.53	31.32	100	333 QP
3	213.33	30.18	-13.32	43.50	49.79	10.04	1.76	31.41	---	Peak
4	338.50	30.51	-15.49	46.00	45.55	14.07	2.29	31.41	---	Peak
5	539.40	31.95	-14.05	46.00	42.05	17.89	3.06	31.05	---	Peak
6	659.80	30.12	-15.88	46.00	38.60	18.99	3.44	30.90	---	Peak



Test Mode :	Mode 3	Temperature :	20~21°C
Test Channel :	11	Relative Humidity :	30~31%
Test Engineer :	Mac Lin	Polarization :	Horizontal
Remark :			

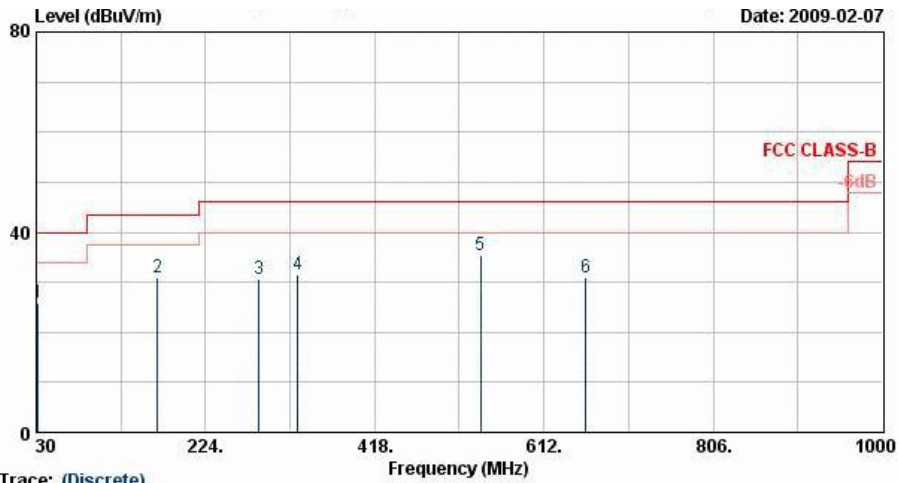

Trace: (Discrete)
 Site : 03CH07-HY
 Condition : FCC CLASS-B 3m BILOG_081118 HORIZONTAL
 Project : FR 803027-02

	Freq	Level	Over	Limit	Read	Antenna	Cable	Preamp	Ant	Table	Remark
	MHz	dBuV/m	dB	dBuV/m	dBuV	dB/m	dB	dB	cm	deg	
1	31.89	25.79	-14.21	40.00	38.57	17.82	0.66	31.26	---	---	Peak
2	169.05	30.98	-12.52	43.50	51.13	9.63	1.55	31.33	---	---	Peak
3	285.69	30.78	-15.22	46.00	47.08	13.08	2.06	31.44	---	---	Peak
4	329.40	31.50	-14.50	46.00	46.77	13.84	2.26	31.37	---	---	Peak
5 @	539.40	35.52	-10.48	46.00	45.61	17.89	3.06	31.05	100	162	Peak
6	659.80	30.87	-15.13	46.00	39.34	18.99	3.44	30.90	---	---	Peak



Test Mode :	Mode 3	Temperature :	20~21°C
Test Channel :	11	Relative Humidity :	30~31%
Test Engineer :	Mac Lin	Polarization :	Vertical
Remark :			

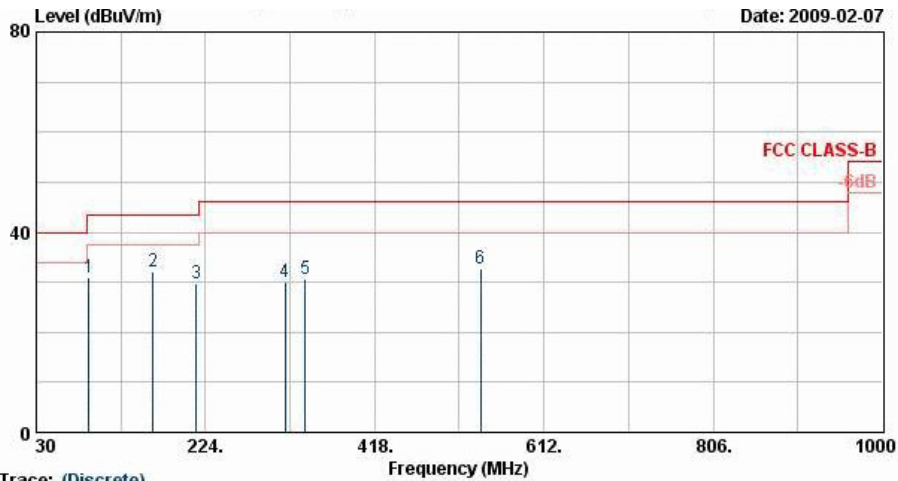

Trace: (Discrete)
 Site : 03CH07-HY
 Condition : FCC CLASS-B 3m BILOG_081118 VERTICAL
 Project : FR 803027-02

	Freq	Level	Over	Limit	Read	Antenna	Cable	Preamp	Ant	Table	Remark
	MHz	dBuV/m	dB	dBuV/m	dBuV	dB/m	dB	dB	cm	deg	
1	90.21	30.99	-12.51	43.50	52.18	9.13	1.11	31.43	---	---	Peak
2	163.65	32.06	-11.44	43.50	52.00	9.85	1.53	31.32	100	332	QP
3	213.06	29.84	-13.66	43.50	49.45	10.04	1.76	31.41	---	---	Peak
4	315.40	30.07	-15.93	46.00	45.78	13.46	2.20	31.37	---	---	Peak
5	338.50	30.70	-15.30	46.00	45.75	14.07	2.29	31.41	---	---	Peak
6	539.40	32.85	-13.15	46.00	42.95	17.89	3.06	31.05	---	---	Peak



Test Mode :	Mode 4	Temperature :	20~21°C
Test Channel :	01	Relative Humidity :	30~31%
Test Engineer :	Mac Lin	Polarization :	Horizontal
Remark :			

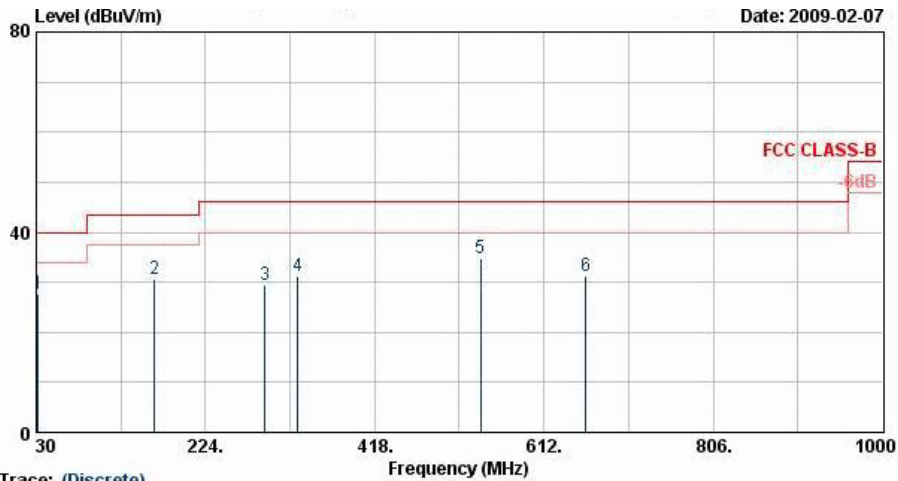

Trace: (Discrete)
 Site : 03CH07-HY
 Condition : FCC CLASS-B 3m BILOG_081118 HORIZONTAL
 Project : FR 803027-02

	Freq	Level	Over	Limit	Read	Antenna	Cable	Preamp	Ant	Table	Remark
	MHz	dBuV/m	dB	dBuV/m	dBuV	dB/m	dB	dB	cm	deg	
1	31.89	27.76	-12.24	40.00	40.55	17.82	0.66	31.26	---	---	Peak
2	165.81	30.49	-13.01	43.50	50.52	9.77	1.53	31.32	---	---	Peak
3	291.90	29.46	-16.54	46.00	45.73	13.07	2.09	31.43	---	---	Peak
4	330.10	31.26	-14.74	46.00	46.53	13.84	2.26	31.37	---	---	Peak
5 @	539.40	34.92	-11.08	46.00	45.02	17.89	3.06	31.05	100	271	Peak
6	659.80	31.21	-14.79	46.00	39.68	18.99	3.44	30.90	---	---	Peak



Test Mode :	Mode 4	Temperature :	20~21°C
Test Channel :	01	Relative Humidity :	30~31%
Test Engineer :	Mac Lin	Polarization :	Vertical
Remark :			

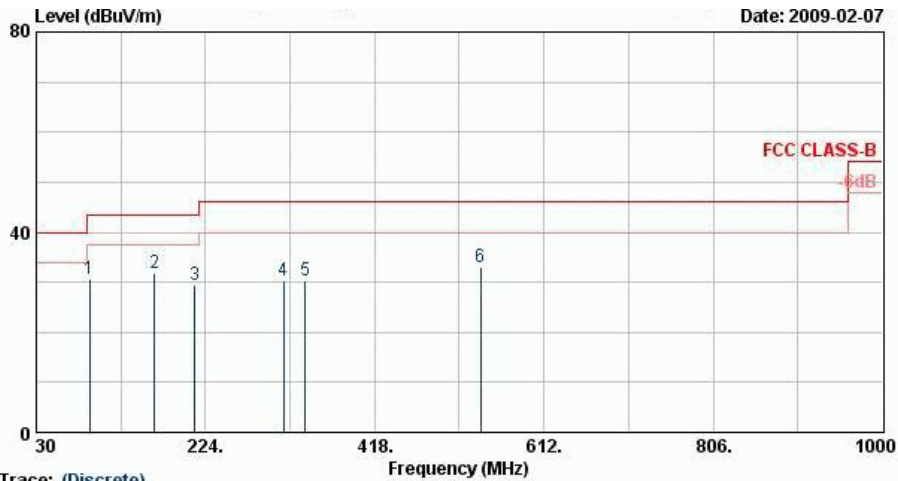

Trace: (Discrete)
 Site : 03CH07-HY
 Condition : FCC CLASS-B 3m BILOG_081118 VERTICAL
 Project : FR 803027-02

	Freq	Level	Over	Limit	Read	Antenna	Cable	Preamp	Ant	Table	Remark
	MHz	dBuV/m	dB	dBuV/m	dBuV	dB/m	dB	dB	cm	deg	
1	91.02	30.71	-12.79	43.50	51.71	9.31	1.12	31.43	---	---	Peak
2	165.54	31.88	-11.62	43.50	51.90	9.77	1.53	31.32	100	330	QP
3	211.98	29.33	-14.17	43.50	49.01	9.96	1.76	31.40	---	---	Peak
4	313.30	30.45	-15.55	46.00	46.23	13.41	2.19	31.38	---	---	Peak
5	338.50	30.30	-15.70	46.00	45.35	14.07	2.29	31.41	---	---	Peak
6	539.40	32.98	-13.02	46.00	43.08	17.89	3.06	31.05	---	---	Peak



Test Mode :	Mode 5	Temperature :	20~21°C
Test Channel :	06	Relative Humidity :	30~31%
Test Engineer :	Mac Lin	Polarization :	Horizontal
Remark :			

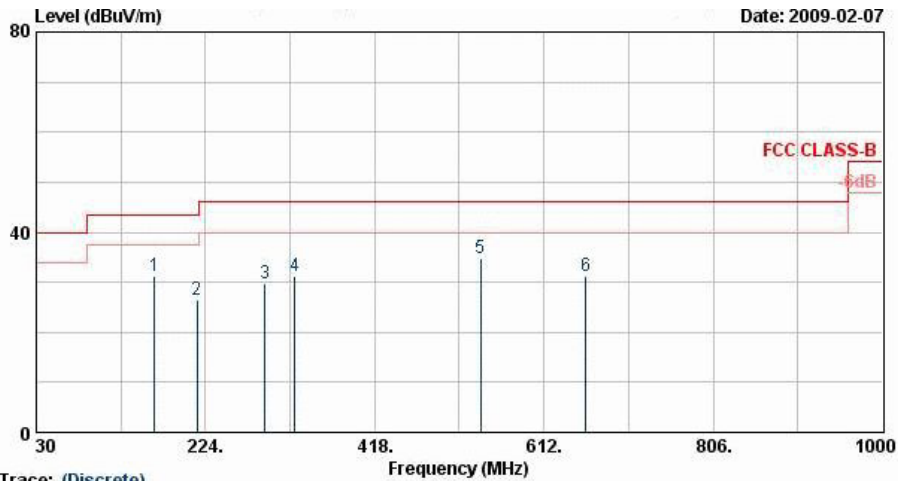

Trace: (Discrete)
 Site : 03CH07-HY
 Condition : FCC CLASS-B 3m BILOG_081118 HORIZONTAL
 Project : FR 803027-02

	Freq	Level	Over	Limit	Read	Antenna	Cable	Preamp	Ant	Table	Remark
	MHz	dBuV/m	dB	dBuV/m	dBuV	dB/m	dB	dB	cm	deg	
1	165.81	31.13	-12.37	43.50	51.15	9.77	1.53	31.32	---	---	Peak
2	214.41	26.47	-17.03	43.50	46.00	10.12	1.77	31.42	---	---	Peak
3	292.17	29.70	-16.30	46.00	45.97	13.07	2.09	31.43	---	---	Peak
4	326.60	31.12	-14.88	46.00	46.47	13.77	2.25	31.36	---	---	Peak
5 @	539.40	34.84	-11.16	46.00	44.94	17.89	3.06	31.05	100	27	Peak
6	659.80	31.26	-14.74	46.00	39.74	18.99	3.44	30.90	---	---	Peak



Test Mode :	Mode 5	Temperature :	20~21°C
Test Channel :	06	Relative Humidity :	30~31%
Test Engineer :	Mac Lin	Polarization :	Vertical
Remark :			

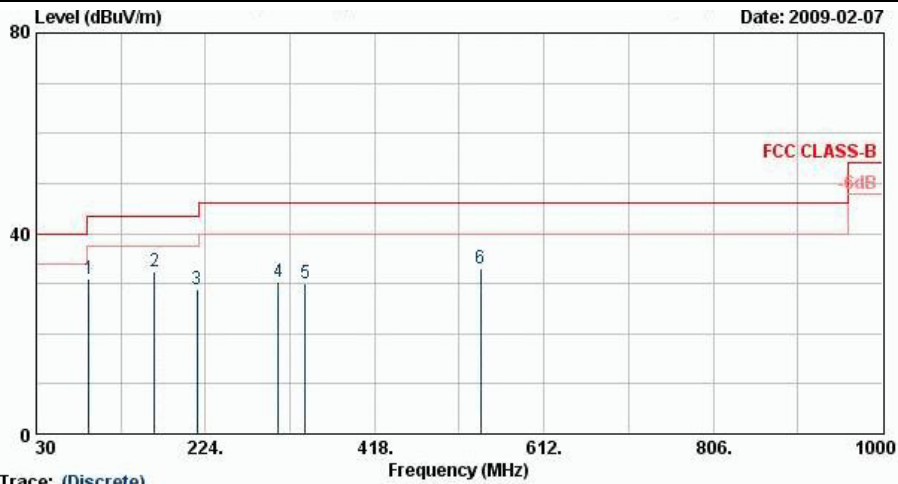

Site : 03CH07-HY
 Condition : FCC CLASS-B 3m BILOG_081118 VERTICAL
 Project : FR 803027-02

	Freq	Level	Over Limit	Limit Line	ReadAntenna Level	Antenna Factor	Cable Loss	Preamp Factor	Ant Pos	Table Pos	Remark
	MHz	dBuV/m	dB	dBuV/m	dBuV	dB/m	dB	dB	cm	deg	
1	90.21	30.85	-12.65	43.50	52.04	9.13	1.11	31.43	---	---	Peak
2	165.54	32.28	-11.22	43.50	52.30	9.77	1.53	31.32	100	337	QP
3	214.14	28.86	-14.64	43.50	48.39	10.12	1.77	31.42	---	---	Peak
4	307.70	30.26	-15.74	46.00	46.22	13.26	2.16	31.39	---	---	Peak
5	338.50	29.90	-16.10	46.00	44.94	14.07	2.29	31.41	---	---	Peak
6	539.40	32.99	-13.01	46.00	43.08	17.89	3.06	31.05	---	---	Peak



Test Mode :	Mode 6	Temperature :	20~21°C
Test Channel :	11	Relative Humidity :	30~31%
Test Engineer :	Mac Lin	Polarization :	Horizontal
Remark :			

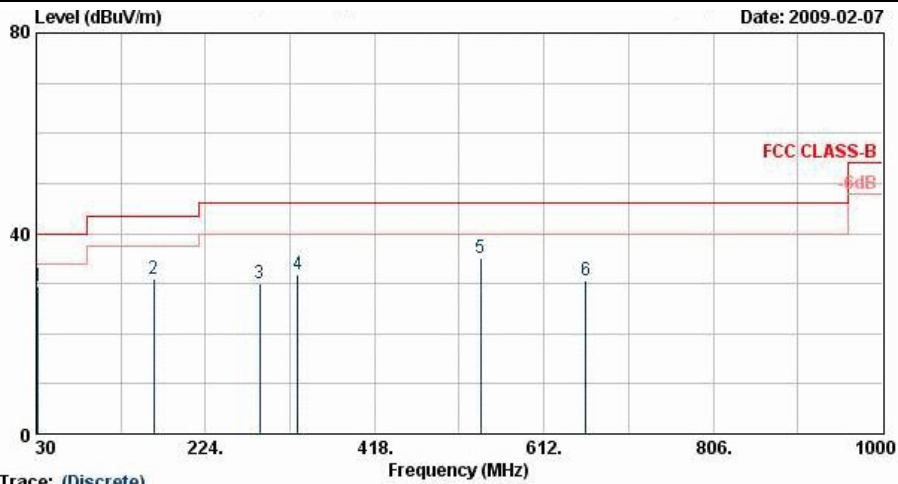

Trace: (Discrete)
 Site : 03CH07-HY
 Condition : FCC CLASS-B 3m BILOG_081118 HORIZONTAL
 Project : FR 803027-02

	Freq	Level	Over	Limit	ReadAntenna	Cable	Preamp	Ant	Table	Remark
	MHz	dBuV/m	dB	dBuV/m	dBuV	dB/m	dB	dB	cm	deg
1 @	31.89	29.58	-10.42	40.00	42.37	17.82	0.66	31.26	100	217 Peak
2	164.73	31.05	-12.45	43.50	51.03	9.81	1.53	31.32	---	---
3	286.50	30.09	-15.91	46.00	46.39	13.08	2.06	31.44	---	---
4	329.40	31.94	-14.06	46.00	47.21	13.84	2.26	31.37	---	---
5	539.40	35.02	-10.98	46.00	45.12	17.89	3.06	31.05	---	---
6	659.80	30.76	-15.24	46.00	39.24	18.99	3.44	30.90	---	---



Test Mode :	Mode 6	Temperature :	20~21°C
Test Channel :	11	Relative Humidity :	30~31%
Test Engineer :	Mac Lin	Polarization :	Vertical
Remark :			

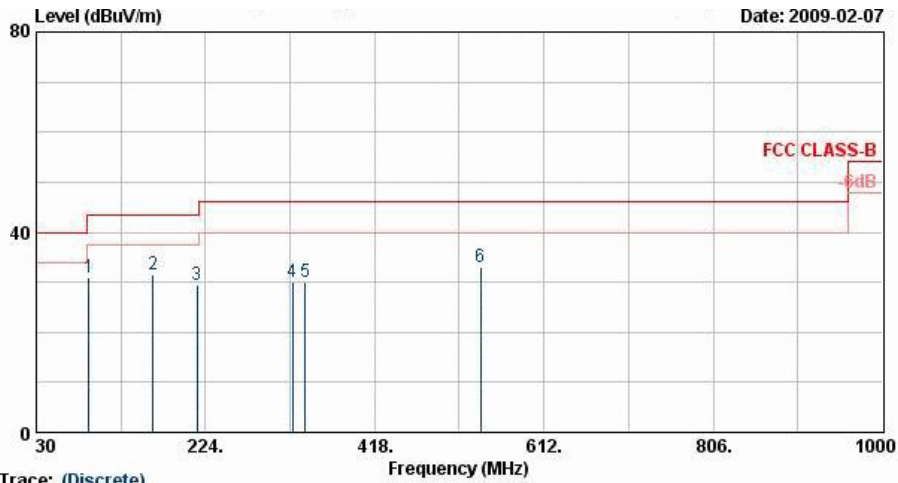

Trace: (Discrete)
 Site : 03CH07-HY
 Condition : FCC CLASS-B 3m BILOG_081118 VERTICAL
 Project : FR 803027-02

	Freq	Level	Over	Limit	Read	Antenna	Cable	Preamp	Ant	Table	Remark
	MHz	dBuV/m	dB	dBuV/m	dBuV	dB/m	dB	dB	cm	deg	
1	90.21	30.94	-12.56	43.50	52.13	9.13	1.11	31.43	---	---	Peak
2	163.65	31.66	-11.84	43.50	51.60	9.85	1.53	31.32	100	327	QP
3	214.41	29.40	-14.10	43.50	48.93	10.12	1.77	31.42	---	---	Peak
4	323.80	30.01	-15.99	46.00	45.43	13.69	2.24	31.35	---	---	Peak
5	338.50	30.08	-15.92	46.00	45.12	14.07	2.29	31.41	---	---	Peak
6	539.40	32.88	-13.12	46.00	42.98	17.89	3.06	31.05	---	---	Peak



3.6.6 Test Result of Radiated Emission ≥ 1 GHz

Test Mode :	Mode 1	Temperature :	20~21°C
Test Channel :	01	Relative Humidity :	30~31%
Test Engineer :	Mac Lin	Polarization :	Horizontal
Remark :	#3 and #4 are Fundamental Signals		

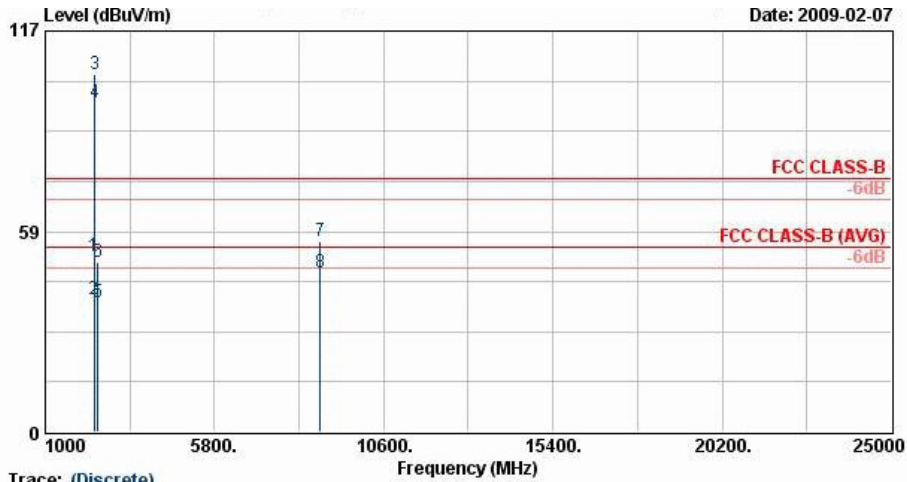

Trace: (Discrete)
 Site : 03CH07-HY
 Condition : FCC CLASS-B 3m SHF-EHF HORN HORIZONTAL
 Project : FR 803027-02

	Freq	Level	Over	Limit	Read	Antenna	Cable	Preamp	Ant	Table	Remark
	MHz	dBuV/m	dB	dBuV/m	dBuV	dB/m	dB	dB	cm	deg	
1	2387.33	51.13	-22.87	74.00	49.03	32.32	5.46	35.68	100	0	Peak
2	2387.33	38.55	-15.45	54.00	36.45	32.32	5.46	35.68	100	326	Average
3 @	2412.00	104.46			102.38	32.32	5.44	35.68	100	0	Peak
4 @	2412.00	96.29			94.21	32.32	5.44	35.68	100	326	Average
5	2500.00	37.90	-16.10	54.00	35.93	32.30	5.37	35.70	100	326	Average
6	2500.00	49.66	-24.34	74.00	47.69	32.30	5.37	35.70	100	0	Peak
7	8805.00	55.52	-18.48	74.00	43.14	38.58	10.28	36.48	100	0	Peak
8 @	8805.00	46.49	-7.51	54.00	34.11	38.58	10.28	36.48	100	148	Average



Test Mode :	Mode 1	Temperature :	20~21°C
Test Channel :	01	Relative Humidity :	30~31%
Test Engineer :	Mac Lin	Polarization :	Vertical
Remark :	#3 and #4 are Fundamental Signals		

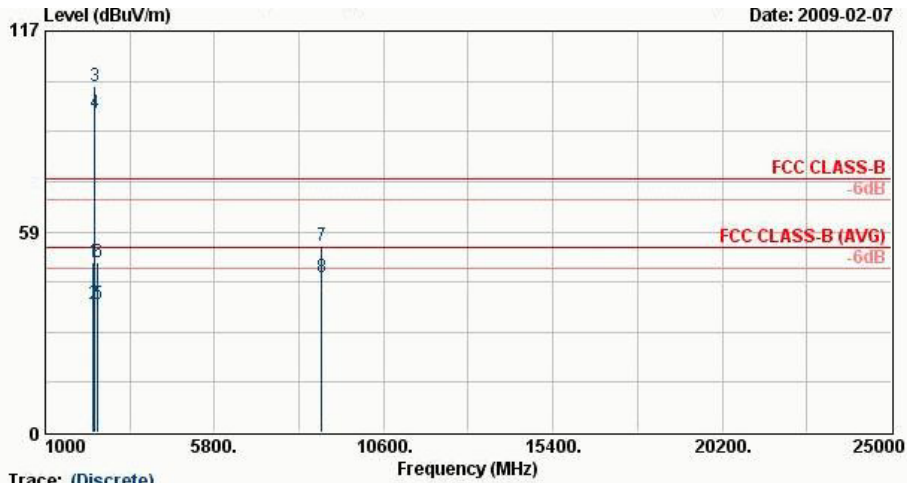

Trace: (Discrete)
 Site : 03CH07-HY
 Condition : FCC CLASS-B 3m SHF-EHF HORN VERTICAL
 Project : FR 803027-02

	Freq	Level	Over Limit	Limit Line	ReadAntenna Level	Cable Loss	Preamp Factor	Ant Pos	Table Pos	Remark
	MHz	dBuV/m	dB	dBuV/m	dBuV	dB/m	dB	cm	deg	
1	2372.13	49.49	-24.51	74.00	47.39	32.30	5.47	35.68	100	0 Peak
2	2372.13	37.35	-16.65	54.00	35.25	32.30	5.47	35.68	190	342 Average
3 @	2412.00	101.09			99.03	32.30	5.44	35.68	100	0 Peak
4 @	2412.00	92.92			90.86	32.30	5.44	35.68	190	342 Average
5	2494.00	37.38	-16.62	54.00	35.41	32.30	5.37	35.70	190	342 Average
6	2494.00	49.52	-24.48	74.00	47.55	32.30	5.37	35.70	100	0 Peak
7	8841.00	54.35	-19.65	74.00	43.06	37.50	10.29	36.50	100	0 Peak
8 @	8841.00	45.34	-8.66	54.00	34.05	37.50	10.29	36.50	100	148 Average



Test Mode :	Mode 2	Temperature :	20~21°C
Test Channel :	06	Relative Humidity :	30~31%
Test Engineer :	Mac Lin	Polarization :	Horizontal
Remark :	#3 and #4 are Fundamental Signals		

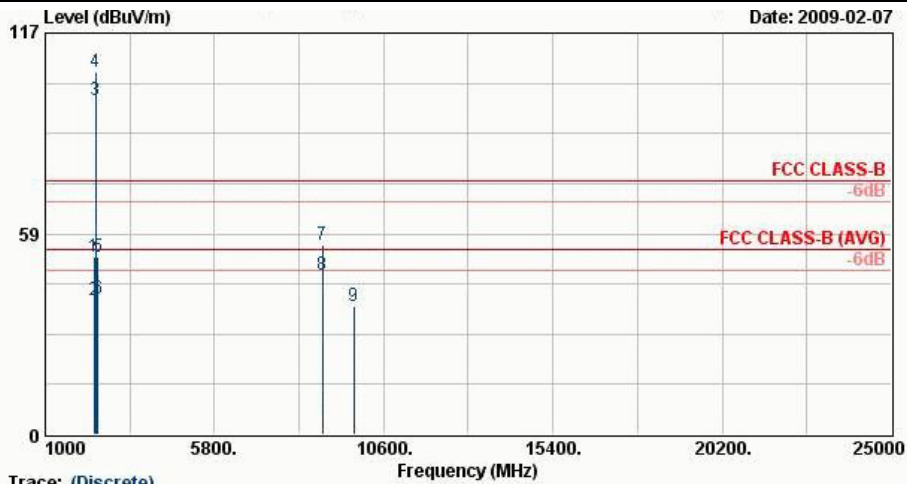

Site : 03CH07-HY
 Condition : FCC CLASS-B 3m SHF-EHF HORN HORIZONTAL
 Project : FR 803027-02

	Freq	Level	Over	Limit	Read	Antenna	Cable	Preamp	Ant	Table	Remark
	MHz	dBuV/m	dB	dBuV/m	dBuV	dB/m	dB	dB	cm	deg	
1	2380.00	51.55	-22.45	74.00	49.43	32.32	5.47	35.68	100	0	Peak
2	2380.00	39.33	-14.67	54.00	37.21	32.32	5.47	35.68	101	304	Average
3 @	2437.00	97.54			95.50	32.31	5.41	35.69	101	304	Average
4 @	2437.00	105.81			103.77	32.31	5.41	35.69	100	0	Peak
5	2494.00	51.68	-22.32	74.00	49.71	32.30	5.37	35.70	100	0	Peak
6	2494.00	39.47	-14.53	54.00	37.50	32.30	5.37	35.70	101	304	Average
7	8853.00	55.31	-18.69	74.00	42.92	38.61	10.29	36.51	100	0	Peak
8 @	8853.00	46.37	-7.63	54.00	33.98	38.61	10.29	36.51	100	241	Average
9	9741.00	37.43	-36.57	74.00	73.24	-9.87	10.81	36.75	100	0	Peak



Test Mode :	Mode 2	Temperature :	20~21°C
Test Channel :	06	Relative Humidity :	30~31%
Test Engineer :	Mac Lin	Polarization :	Vertical
Remark :	#3 and #4 are Fundamental Signals		

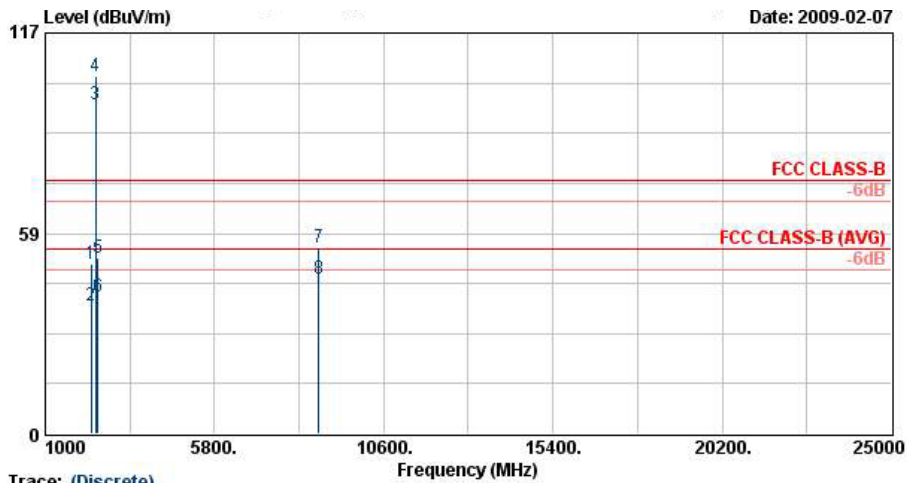

Trace: (Discrete)
 Site : 03CH07-HY
 Condition : FCC CLASS-B 3m SHF-EHF HORN VERTICAL
 Project : FR 803027-02

	Freq	Level	Over	Limit	ReadAntenna	Cable	Preamp	Ant	Table	Remark
	MHz	dBuV/m	dB	dBuV/m	dBuV	dB/m	dB	dB	cm	deg
1	2310.00	49.42	-24.58	74.00	47.25	32.30	5.53	35.66	100	0 Peak
2	2310.00	37.21	-16.79	54.00	35.04	32.30	5.53	35.66	132	329 Average
3 @	2437.00	96.29			94.26	32.30	5.41	35.69	132	329 Average
4 X	2437.00	104.43			102.40	32.30	5.41	35.69	100	0 Peak
5	2492.00	51.53	-22.47	74.00	49.56	32.30	5.37	35.70	100	0 Peak
6	2492.00	40.21	-13.79	54.00	38.24	32.30	5.37	35.70	132	329 Average
7	8757.00	54.16	-19.84	74.00	42.90	37.45	10.26	36.45	100	0 Peak
8	8757.00	45.16	-8.84	54.00	33.90	37.45	10.26	36.45	100	165 Average



Test Mode :	Mode 3	Temperature :	20~21°C
Test Channel :	11	Relative Humidity :	30~31%
Test Engineer :	Mac Lin	Polarization :	Horizontal
Remark :	#3 and #4 are Fundamental Signals		

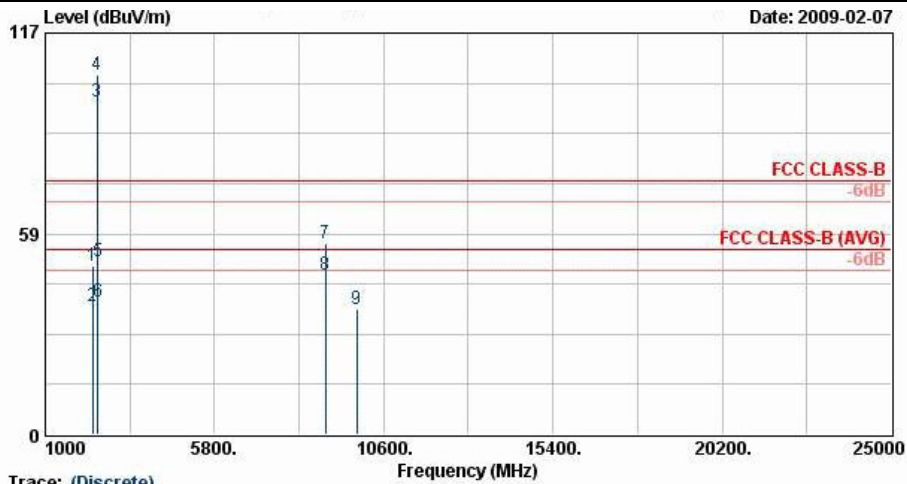

Site : 03CH07-HY
 Condition : FCC CLASS-B 3m SHF-EHF HORN HORIZONTAL
 Project : FR 803027-02

	Freq	Level	Over	Limit	ReadAntenna	Cable	Preamp	Ant	Table	Remark
	MHz	dBuV/m	Limit	Line	Level	Loss	Factor	Pos	Pos	
			dB	dBuV/m	dBuV	dB	dB	cm	deg	
1	2334.00	49.37	-24.63	74.00	47.18	32.33	5.51	35.67	100	0 Peak
2	2334.00	37.34	-16.66	54.00	35.16	32.33	5.51	35.67	100	324 Average
3 @	2462.00	96.84			94.82	32.31	5.40	35.69	100	324 Average
4 @	2462.00	104.90			102.88	32.31	5.40	35.69	100	0 Peak
5	2483.50	50.47	-23.53	74.00	48.48	32.30	5.38	35.70	100	0 Peak
6	2483.50	38.88	-15.12	54.00	36.89	32.30	5.38	35.70	100	324 Average
7	8937.00	55.66	-18.34	74.00	43.24	38.66	10.32	36.56	100	0 Peak
8 @	8937.00	46.71	-7.29	54.00	34.29	38.66	10.32	36.56	100	32 Average
9	9846.00	36.59	-37.41	74.00	72.10	-9.63	10.89	36.77	100	0 Peak



Test Mode :	Mode 3	Temperature :	20~21°C
Test Channel :	11	Relative Humidity :	30~31%
Test Engineer :	Mac Lin	Polarization :	Vertical
Remark :	#3 and #4 are Fundamental Signals		

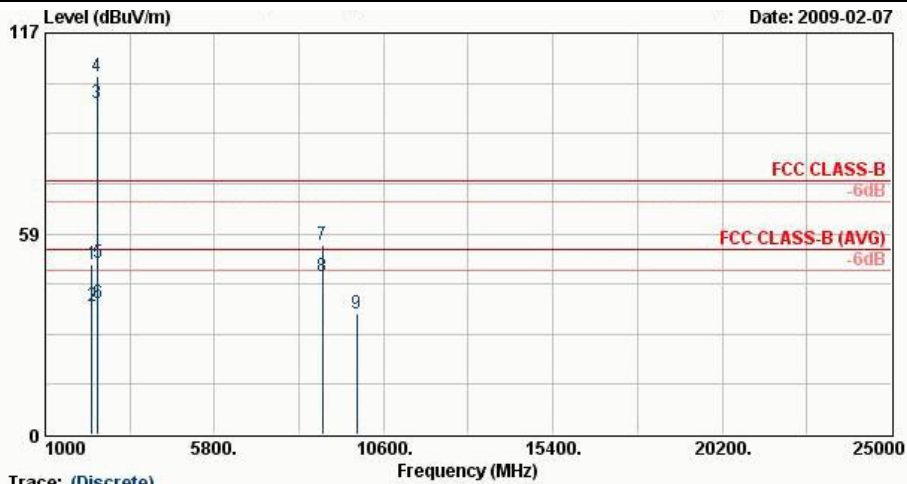

Site : 03CH07-HY
 Condition : FCC CLASS-B 3m SHF-EHF HORN VERTICAL
 Project : FR 803027-02

	Freq	Level	Over	Limit	ReadAntenna	Cable	Preamp	Ant	Table	Remark
	MHz	dBuV/m	dB	dBuV/m	dBuV	dB/m	dB	dB	cm	deg
1	2332.00	49.57	-24.43	74.00	47.42	32.30	5.51	35.67	100	0 Peak
2	2332.00	37.44	-16.56	54.00	35.29	32.30	5.51	35.67	131	335 Average
3 @	2462.00	96.41			94.40	32.30	5.40	35.69	131	335 Average
4 @	2462.00	104.52			102.51	32.30	5.40	35.69	100	0 Peak
5	2483.50	50.07	-23.93	74.00	48.08	32.30	5.38	35.70	100	0 Peak
6	2483.50	38.49	-15.51	54.00	36.50	32.30	5.38	35.70	131	335 Average
7	8865.00	55.28	-18.72	74.00	43.98	37.52	10.30	36.51	100	0 Peak
8 @	8865.00	46.30	-7.70	54.00	34.99	37.52	10.30	36.51	100	26 Average
9	9846.00	35.25	-38.75	74.00	70.76	-9.63	10.89	36.77	100	0 Peak



Test Mode :	Mode 4	Temperature :	20~21°C
Test Channel :	01	Relative Humidity :	30~31%
Test Engineer :	Mac Lin	Polarization :	Horizontal
Remark :	#3 and #4 are Fundamental Signals		

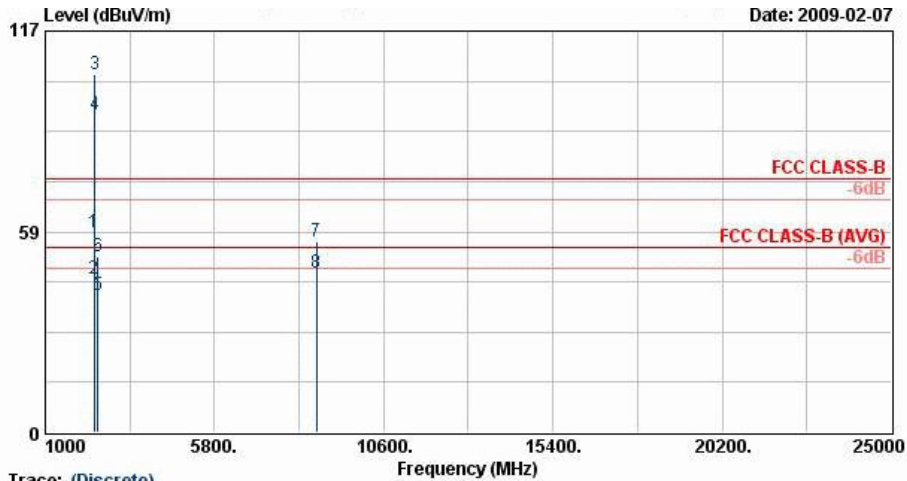

Site : 03CH07-HY
 Condition : FCC CLASS-B 3m SHF-EHF HORN HORIZONTAL
 Project : FR 803027-02

	Freq	Level	Over	Limit	ReadAntenna	Cable	Preamp	Ant	Table	Remark
	MHz	dBuV/m	dB	dBuV/m	dBuV	dB/m	dB	dB	cm	deg
1	2389.99	58.36	-15.64	74.00	56.26	32.32	5.46	35.68	100	0 Peak
2 @	2389.99	44.64	-9.36	54.00	42.54	32.32	5.46	35.68	102	325 Average
3 @	2412.00	104.31			102.25	32.31	5.43	35.69	100	0 Peak
4 @	2412.00	92.66			90.58	32.32	5.44	35.68	102	325 Average
5	2492.00	39.91	-14.09	54.00	37.94	32.30	5.37	35.70	102	325 Average
6	2492.00	51.22	-22.78	74.00	49.25	32.30	5.37	35.70	100	0 Peak
7	8697.00	55.69	-18.31	74.00	43.35	38.52	10.24	36.42	100	0 Peak
8 @	8697.00	46.67	-7.33	54.00	34.33	38.52	10.24	36.42	100	189 Average



Test Mode :	Mode 4	Temperature :	20~21°C
Test Channel :	01	Relative Humidity :	30~31%
Test Engineer :	Mac Lin	Polarization :	Vertical
Remark :	#3 and #4 are Fundamental Signals		

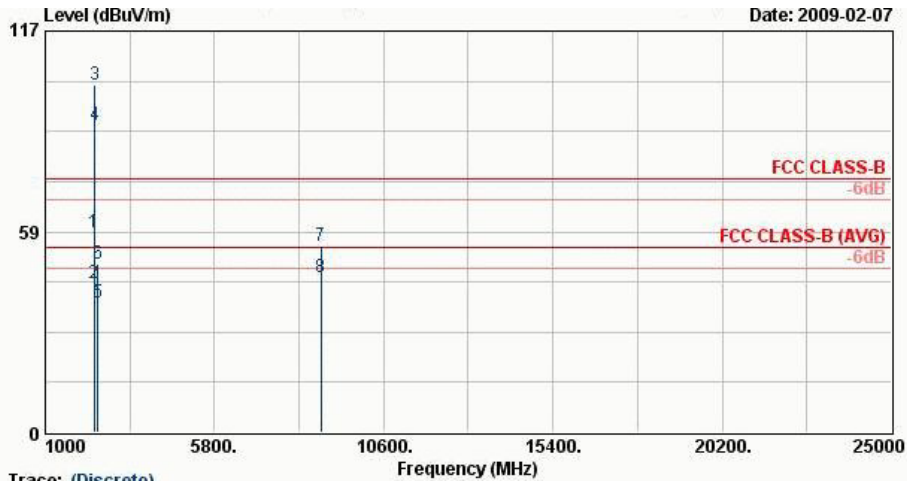

Trace: (Discrete)
 Site : 03CH07-HY
 Condition : FCC CLASS-B 3m SHF-EHF HORN VERTICAL
 Project : FR 803027-02

	Freq	Level	Over	Limit	ReadAntenna	Cable	Preamp	Ant	Table	Remark
	MHz	dBuV/m	dB	dBuV/m	dBuV	dB/m	dB	dB	cm	deg
1	2389.99	58.26	-15.74	74.00	56.18	32.30	5.46	35.68	100	0 Peak
2 @	2389.99	43.66	-10.34	54.00	41.58	32.30	5.46	35.68	194	342 Average
3 @	2412.00	101.23			99.19	32.30	5.43	35.69	100	0 Peak
4 @	2412.00	89.69			87.63	32.30	5.44	35.68	194	342 Average
5	2494.00	37.81	-16.19	54.00	35.84	32.30	5.37	35.70	194	342 Average
6	2494.00	49.17	-24.83	74.00	47.20	32.30	5.37	35.70	100	0 Peak
7	8829.00	54.41	-19.59	74.00	43.12	37.50	10.29	36.50	100	0 Peak
8 @	8829.00	45.40	-8.60	54.00	34.11	37.50	10.29	36.50	100	109 Average



Test Mode :	Mode 5	Temperature :	20~21°C
Test Channel :	06	Relative Humidity :	30~31%
Test Engineer :	Mac Lin	Polarization :	Horizontal
Remark :	#3 and #4 are Fundamental Signals		

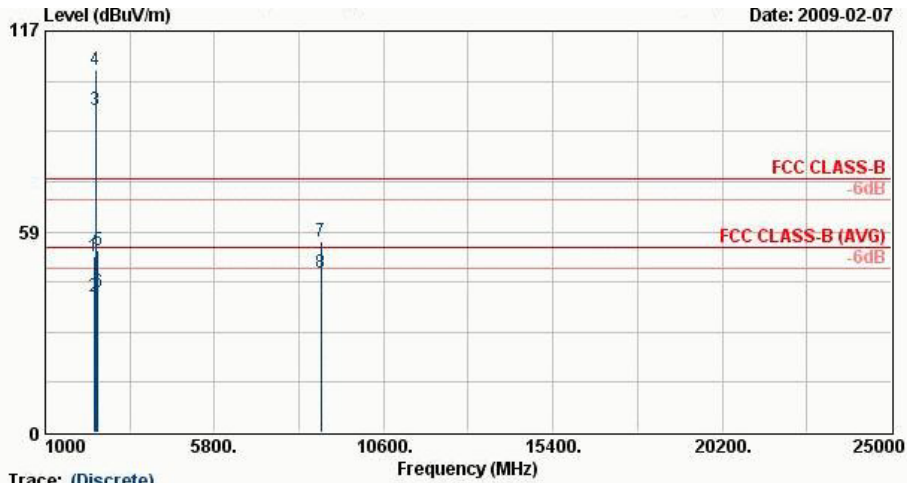

Trace: (Discrete)
 Site : 03CH07-HY
 Condition : FCC CLASS-B 3m SHF-EHF HORN HORIZONTAL
 Project : FR 803027-02

	Freq	Level	Over	Limit	ReadAntenna	Cable	Preamp	Ant	Table	Remark
	MHz	dBuV/m	dB	dBuV/m	dBuV	dB/m	dB	dB	cm	deg
1	2390.00	51.31	-22.69	74.00	49.21	32.32	5.46	35.68	100	0 Peak
2	2390.00	39.53	-14.47	54.00	37.43	32.32	5.46	35.68	100	301 Average
3 @	2437.00	93.92			91.88	32.31	5.41	35.69	100	301 Average
4 @	2437.00	105.57			103.54	32.31	5.41	35.69	100	0 Peak
5	2484.00	53.01	-20.99	74.00	51.01	32.30	5.38	35.70	100	0 Peak
6	2484.00	40.77	-13.23	54.00	38.78	32.30	5.38	35.70	100	301 Average
7	8829.00	55.62	-18.38	74.00	43.23	38.60	10.29	36.50	100	0 Peak
8 @	8829.00	46.60	-7.40	54.00	34.21	38.60	10.29	36.50	100	22 Average



Test Mode :	Mode 5	Temperature :	20~21°C
Test Channel :	06	Relative Humidity :	30~31%
Test Engineer :	Mac Lin	Polarization :	Vertical
Remark :	#3 and #4 are Fundamental Signals		

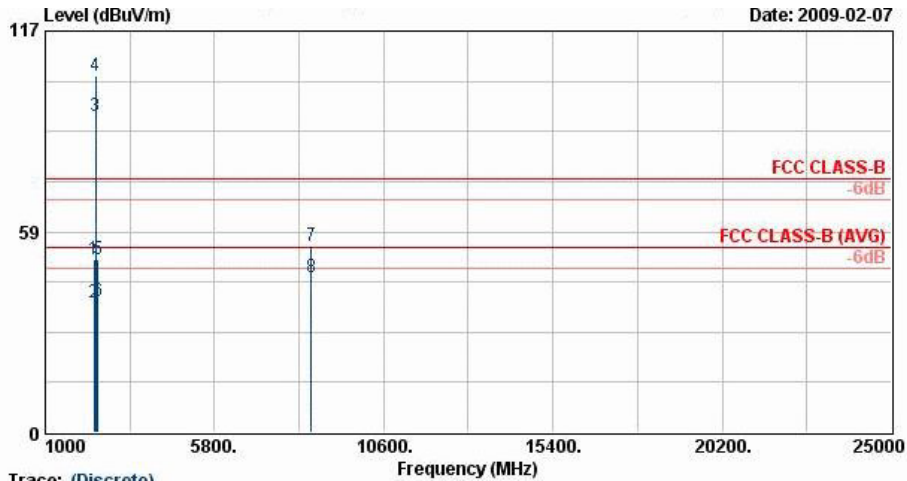

Trace: (Discrete)
 Site : 03CH07-HY
 Condition : FCC CLASS-B 3m SHF-EHF HORN VERTICAL
 Project : FR 803027-02

	Freq	Level	Over	Limit	ReadAntenna	Cable	Preamp	Ant	Table	Remark
	MHz	dBuV/m	dB	dBuV/m	dBuV	dB/m	dB	dB	cm	deg
1	2390.00	50.50	-23.50	74.00	48.42	32.30	5.46	35.68	100	0 Peak
2	2390.00	37.78	-16.22	54.00	35.70	32.30	5.46	35.68	109	349 Average
3 @	2437.00	92.40			90.37	32.30	5.41	35.69	109	349 Average
4 @	2437.00	103.82			101.79	32.30	5.41	35.69	100	0 Peak
5	2486.00	50.30	-23.70	74.00	48.31	32.30	5.38	35.70	100	0 Peak
6	2486.00	38.49	-15.51	54.00	36.50	32.30	5.38	35.70	109	349 Average
7	8538.00	54.30	-19.70	74.00	43.12	37.32	10.19	36.33	100	0 Peak
8 @	8538.00	45.35	-8.65	54.00	34.17	37.32	10.19	36.33	100	300 Average



Test Mode :	Mode 6	Temperature :	20~21°C
Test Channel :	11	Relative Humidity :	30~31%
Test Engineer :	Mac Lin	Polarization :	Horizontal
Remark :	#3 and #4 are Fundamental Signals		

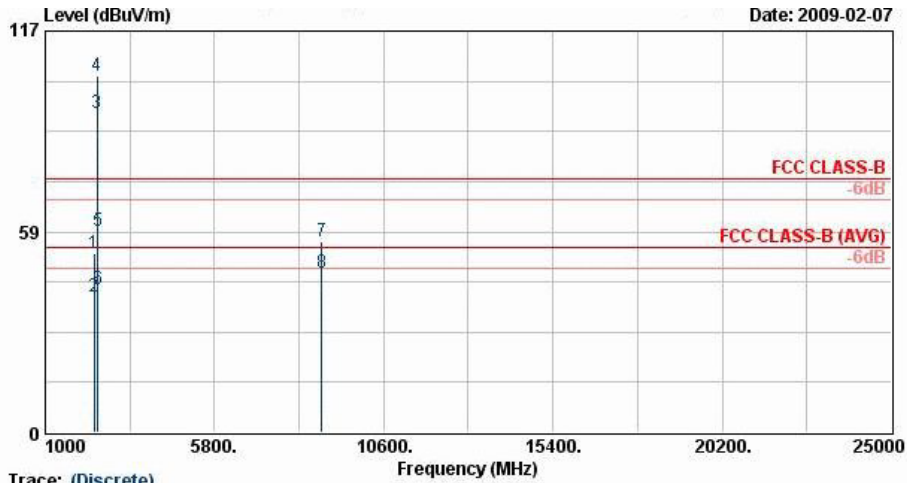

Trace: (Discrete)
 Site : 03CH07-HY
 Condition : FCC CLASS-B 3m SHF-EHF HORN HORIZONTAL
 Project : FR 803027-02

	Freq	Level	Over	Limit	ReadAntenna	Cable	Preamp	Ant	Table	Remark
	MHz	dBuV/m	dB	dBuV/m	dBuV	dB/m	dB	dB	cm	deg
1	2388.00	52.11	-21.89	74.00	50.01	32.32	5.46	35.68	100	0 Peak
2	2388.00	39.72	-14.28	54.00	37.62	32.32	5.46	35.68	100	303 Average
3 @	2462.00	92.91			90.89	32.31	5.40	35.69	100	303 Average
4 @	2462.00	103.74			101.73	32.31	5.40	35.70	100	0 Peak
5	2483.50	58.88	-15.12	74.00	56.89	32.30	5.38	35.70	100	0 Peak
6	2483.50	41.89	-12.11	54.00	39.90	32.30	5.38	35.70	100	303 Average
7	8850.00	55.59	-18.41	74.00	43.19	38.61	10.29	36.51	100	0 Peak
8 @	8850.00	46.49	-7.51	54.00	34.10	38.61	10.29	36.51	100	40 Average



Test Mode :	Mode 6	Temperature :	20~21°C
Test Channel :	11	Relative Humidity :	30~31%
Test Engineer :	Mac Lin	Polarization :	Vertical
Remark :	#3 and #4 are Fundamental Signals		

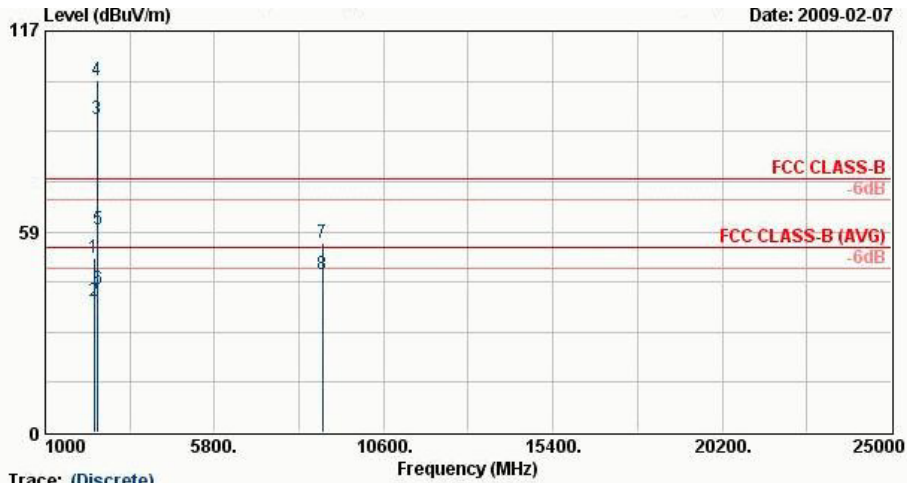

Trace: (Discrete)
 Site : 03CH07-HY
 Condition : FCC CLASS-B 3m SHF-EHF HORN VERTICAL
 Project : FR 803027-02

	Freq	Level	Over	Limit	ReadAntenna	Cable	Preamp	Ant	Table	Remark
	MHz	dBuV/m	dB	dBuV/m	dBuV	dB/m	dB	dB	cm	deg
1	2390.00	51.09	-22.91	74.00	49.01	32.30	5.46	35.68	100	0 Peak
2	2390.00	38.13	-15.87	54.00	36.05	32.30	5.46	35.68	104	348 Average
3 @	2462.00	91.26			89.25	32.30	5.40	35.69	104	348 Average
4 @	2462.00	102.46			100.45	32.30	5.40	35.69	100	0 Peak
5	2483.50	59.28	-14.72	74.00	57.29	32.30	5.38	35.70	100	0 Peak
6	2483.50	41.94	-12.06	54.00	39.95	32.30	5.38	35.70	104	348 Average
7	8862.00	55.06	-18.94	74.00	43.77	37.51	10.29	36.51	100	0 Peak
8 @	8862.00	46.08	-7.92	54.00	34.79	37.51	10.29	36.51	100	347 Average



3.7 Antenna Requirements

3.7.1 Standard Applicable

If directional gain of transmitting antennas is greater than 6dBi, the power shall be reduced by the same level in dB comparing to gain minus 6dBi. For the fixed point-to-point operation, the power shall be reduced by one dB for every 3 dB that the directional gain of the antenna exceeds 6 dBi.

The use of a permanently attached antenna or of an antenna that uses a unique coupling to the intentional radiator shall be considered sufficient to comply with the FCC rule.

3.7.2 Antenna Connected Construction

The antennas type used in this product is PIFA Antenna without connector and it is considered to meet antenna requirement.

3.7.3 Antenna Gain

The antenna peak gain of EUT is less than 6 dBi. Therefore, it is not necessary to reduce maximum peak output power limit.

4 List of Measuring Equipments

Instrument	Manufacturer	Model No.	Serial No.	Characteristics	Calibration Date	Due Date	Remark
Spectrum Analyzer	R&S	FSP40	100055	9kHz~40GHz	Jun. 26, 2008	Jun. 25, 2009	Conducted (TH02-HY)
Power Meter	Agilent	E4416A	GB41292344	N/A	Feb. 21, 2008	Feb. 20, 2009	Conducted (TH02-HY)
Power Sensor	Agilent	E9327A	US40441548	N/A	Feb. 21, 2008	Feb. 20, 2009	Conducted (TH02-HY)
System Simulator	R&S	CMU200	117591	N/A	Oct. 23, 2008	Oct. 22, 2009	Radiation (03CH07-HY)
Bilog Antenna	SCHAFFNER	CBL6111C	2726	30MHz~1GHz	Nov. 20, 2008	Nov. 19, 2009	Radiation (03CH07-HY)
Spectrum Analyzer	R&S	FSP	101067	9kHz~30GHz	Dec. 02, 2008	Dec. 01, 2009	Radiation (03CH07-HY)
BT Base Station	R&S	CBT 2	100519	N/A	May 10, 2007	May 09, 2009	Radiation (03CH07-HY)
SHF-EHF Horn Antenna	SCHWARZBECK	BBHA 9170	BBHA9170251	15G - 40GHz	Oct. 16, 2008	Oct. 15, 2009	Radiation (03CH07-HY)
Double Ridge Horn Antenna	ESCO	3117	75962	1G~18GHz	Aug. 13, 2008	Aug. 12, 2009	Radiation (03CH07-HY)
Pre Amplifier	Agilent	8449B	3008A02362	1G~26.5GHz	Dec. 17, 2008	Dec. 16, 2009	Radiation (03CH07-HY)
Pre Amplifier	COM-POWER	PA-103A	161241	10~1000MHz. 32dB.GAIN	Mar. 31, 2008	Mar. 30, 2009	Radiation (03CH07-HY)
Double Ridge Horn Antenna	ESCO	3117	66584	1G~18GHz	Aug. 06, 2008	Aug. 05, 2009	Radiation (03CH07-HY)
EMI Receiver	R&S	ESCS 30	100356	9kHz~2.75GHz	Aug. 01, 2008	Jul. 31, 2009	Conduction (CO05-HY)
Two-LISN	R&S	ENV216	11-100081	9kHz~30MHz	Nov. 26, 2008	Nov. 25, 2009	Conduction (CO05-HY)
Two-LISN	R&S	ENV216	11-100080	9kHz~30MHz	Nov. 26, 2008	Nov. 25, 2009	Conduction (CO05-HY)
AC Power Source	APC	APC-1000W	N/A	N/A	N/A	N/A	Conduction (CO05-HY)

5 Uncertainty of Evaluation

Uncertainty of Conducted Emission Measurement (150kHz ~ 30MHz)

Contribution	Uncertainty of x_i		$u(x_i)$
	dB	Probability Distribution	
Receiver reading	0.10	Normal(k=2)	0.05
Cable loss	0.10	Normal(k=2)	0.05
AMN insertion loss	2.50	Rectangular	0.63
Receiver Spec	1.50	Rectangular	0.43
Site imperfection	1.39	Rectangular	0.80
Mismatch	+0.34/-0.35	U-shape	0.24
Combined standard uncertainty Uc(y)	1.13		
Measuring uncertainty for a level of confidence of 95% U=2Uc(y)	2.26		

Uncertainty of Radiated Emission Measurement (30MHz ~ 1000MHz)

Contribution	Uncertainty of x_i		$u(x_i)$
	dB	Probability Distribution	
Receiver reading	0.41	Normal(k=2)	0.21
Antenna factor calibration	0.83	Normal(k=2)	0.42
Cable loss calibration	0.25	Normal(k=2)	0.13
Pre Amplifier Gain calibration	0.27	Normal(k=2)	0.14
RCV/SPA specification	2.50	Rectangular	0.72
Antenna Factor Interpolation for Frequency	1.00	Rectangular	0.29
Site imperfection	1.43	Rectangular	0.83
Mismatch	+0.39/-0.41	U-shaped	0.28
Combined standard uncertainty Uc(y)	1.27		
Measuring uncertainty for a level of confidence of 95% U=2Uc(y)	2.54		

Uncertainty of Radiated Emission Measurement (1GHz ~ 40GHz)

Contribution	Uncertainty of x_i		$u(x_i)$	C_i	$C_i * u(x_i)$
	dB	Probability Distribution			
Receiver reading	±0.10	Normal(k=1)	0.10	1	0.10
Antenna factor calibration	±1.70	Normal(k=2)	0.85	1	0.85
Cable loss calibration	±0.50	Normal(k=2)	0.25	1	0.25
Receiver Correction	±2.00	Rectangular	1.15	1	1.15
Antenna Factor Directional	±1.50	Rectangular	0.87	1	0.87
Site imperfection	±2.80	Triangular	1.14	1	1.14
Mismatch Receiver VSWR $\Gamma_1 = 0.197$ Antenna VSWR $\Gamma_2 = 0.194$ Uncertainty = $20 \log(1 - \Gamma_1 * \Gamma_2)$	+0.34/-0.35	U-shaped	0.244	1	0.244
Combined standard uncertainty $U_c(y)$	2.36				
Measuring uncertainty for a level of confidence of 95% $U = 2U_c(y)$	4.72				

6 Certification of TAF Accreditation



Certificate No. : L1190-081212

財團法人全國認證基金會
Taiwan Accreditation Foundation

Certificate of Accreditation

This is to certify that

Sporton International Inc.
EMC & Wireless Communications Laboratory
No.52, Hwa Ya 1st Rd., Hwa Ya Technology Park, Kwei-Shan Hsiang, Tao Yuan Hsien,
Taiwan, R.O.C.

is accredited in respect of laboratory

Accreditation Criteria	: ISO/IEC 17025:2005
Accreditation Number	: 1190
Originally Accredited	: December 15, 2003
Effective Period	: January 10, 2007 to January 09, 2010
Accredited Scope	: Testing Field, see described in the Appendix
Specific Accreditation Program	: Accreditation Program for Designated Testing Laboratory for Commodities Inspection Accreditation Program for Telecommunication Equipment Testing Laboratory Accreditation Program for BSMI Mutual Recognition Arrangement with Foreign Authorities

Jay-San Chen
President, Taiwan Accreditation Foundation
Date : December 12, 2008

PI, total 18 pages

The Appendix forms an integral part of this Certificate, which shall be invalid when use without the Appendix



Appendix A. Photographs of EUT

Please refer to Sporton report number EP8O3027-02 as below.