



# DFS TEST REPORT

**REPORT NO.:** RF960308H04

**MODEL NO.:** 21-92955

**RECEIVED:** March 09, 2007

**TESTED:** March 20 to 29, 2007

**ISSUED:** May 22, 2007

**APPLICANT:** Symbol Technologies Inc.

**ADDRESS:** One Symbol Plaza, Holtsville, NY 11742-1300 U.S.A.

**ISSUED BY:** Advance Data Technology Corporation

**TEST LOCATION:** No. 81-1, Lu Liao Keng, 9 Ling, Wu Lung Tsuen, Chiung Lin Hsiang, Hsin Chu Hsien, Taiwan, R.O.C.

This test report consists of 20 pages in total. It may be duplicated completely for legal use with the approval of the applicant. It should not be reproduced except in full, without the written approval of our laboratory. The client should not use it to claim product endorsement by CNLA, A2LA or any government agencies. The test results in the report only apply to the tested sample.



## Table of Contents

1.	CERTIFICATION .....	3
2.	SUMMARY OF TEST RESULTS .....	4
2.1	DYNAMIC FREQUENCY SELECTION .....	4
2.1.1	OPERATING FREQUENCY OF U-NII DEVICE .....	5
2.1.2	TEST LIMITS AND RADAR SIGNAL PARAMETERS .....	5
2.1.3	TEST INSTRUMENTS .....	8
2.1.4	DESCRIPTION OF SUPPORT UNITS .....	8
2.1.5	SOFTWARE AND FIRMWARE .....	8
2.1.6	DESCRIPTION OF AVAILABLE ANTENNAS .....	9
2.1.7	MAXIMUM AND MINIMUM CONDUCTED POWER .....	9
2.1.8	MAXIMUM AND MINIMUM E.I.R.P. POWER .....	9
2.1.9	STATEMENT OF MAUNFACTURER .....	10
2.1.10	TEST PROCEDURE .....	10
2.1.11	DEVIATION FROM TEST STANDARD .....	12
2.1.12	CONDUCTED TEST SETUP CONFIGURATION .....	12
2.1.13	LIST OF MEASUREMENTS .....	13
2.1.14	TEST RESULTS .....	14
2.2	ANTENNA REQUIREMENT .....	18
2.2.1	STANDARD APPLICABLE .....	18
2.2.2	ANTENNA CONNECTED CONSTRUCTION .....	18
3	INFORMATION ON THE TESTING LABORATORIES .....	19
	APPENDIX-A .....	A-1



## 1. CERTIFICATION

**PRODUCT:** 802.11a/b/g WLAN SDIO Radio Module  
**BRAND NAME:** Symbol Technologies Inc.  
**MODEL NO.:** 21-92955  
**TEST SAMPLE:** ENGINEERING SAMPLE  
**TESTED:** March 20 to 29, 2007  
**APPLICANT:** Symbol Technologies Inc.  
**STANDARDS:** **FCC Part 15, Subpart E (Section 15.407)**  
FCC 06-96

The above equipment (Model: 21-92955) has been tested by **Advance Data Technology Corporation**, and found compliance with the requirement of the above standards. The test record, data evaluation & Equipment Under Test (EUT) configurations represented herein are true and accurate accounts of the measurements of the sample's EMC characteristics under the conditions specified in this report.

**PREPARED BY :** Carol Liao , **DATE:** May 22, 2007  
( Carol Liao )

**TECHNICAL ACCEPTANCE :** Moris Lin , **DATE:** May 22, 2007  
Responsible for RF ( Moris Lin )

**APPROVED BY :** Hank Chung , **DATE:** May 22, 2007  
(Hank Chung, Deputy Manager )

### Revision Note:

Revision No.	Revised Date	Comment
Rev.1.0	May 21, 2007	Report was re-issued due to revise page 10 & 15
Rev.2.0	May 22, 2007	Report was re-issued due to revise page 16

## 2. SUMMARY OF TEST RESULTS

### 2.1 DYNAMIC FREQUENCY SELECTION

The manufacturer shall state whether the UUT is capable of operating as a Master and/or a Client. If the UUT is capable of operating in more than one operating mode then each operating mode shall be tested separately. See tables 1 and 2 for the applicability of DFS requirements for each of the operational modes.

**Table 1: Applicability of DFS requirements prior to use a channel**

Requirement	Operational Mode		
	Master	Client without radar detection	Client with radar detection
Non-Occupancy Period	ü	Not required	ü
DFS Detection Threshold	ü	Not required	ü
Channel Availability Check Time	ü	Not required	Not required
Uniform Spreading	ü	Not required	Not required
U-NII Detection Bandwidth	ü	Not required	ü

**Table 2: Applicability of DFS requirements during normal operation.**

Requirement	Operational Mode		
	Master	Client without radar detection	Client with radar detection
DFS Detection Threshold	ü	Not required	ü
Channel Closing Transmission Time	ü	ü	ü
Channel Move Time	ü	ü	ü
U-NII Detection Bandwidth	ü	Not required	ü

## 2.1.1 OPERATING FREQUENCY OF U-NII DEVICE

**Table 3: Operating frequency range of UUT.**

Operational Mode	Operating Frequency Range	
	5250~5350MHz	5470~5725MHz
Master	ü	ü
Client without radar detection	Not Apply	Not Apply
Client with radar detection	ü	ü

## 2.1.2 TEST LIMITS AND RADAR SIGNAL PARAMETERS

### DETECTION THRESHOLD VALUES

**Table 4: DFS Detection Thresholds for Master Devices and Client Devices With Radar Detection.**

Maximum Transmit Power	Value (See Notes 1 and 2)
≥ 200 milliwatt	-64 dBm
< 200 milliwatt	-62 dBm

Note 1: This is the level at the input of the receiver assuming a 0 dBi receive antenna.

Note 2: Throughout these test procedures an additional 1 dB has been added to the amplitude of the test transmission waveforms to account for variations in measurement equipment. This will ensure that the test signal is at or above the detection threshold level to trigger a DFS response.

**Table 5: DFS Response Requirement Values**

Parameter	Value
Non-occupancy period	Minimum 30 minutes
Channel Availability Check Time	60 seconds
Channel Move Time	10 seconds See Note 1.
Channel Closing Transmission Time	200 milliseconds + an aggregate of 60 milliseconds over remaining 10 second period. See Notes 1 and 2.
U-NII Detection Bandwidth	Minimum 80% of the UNII 99% transmission power bandwidth. See Note 3.
<p><b>Note 1:</b> The instant that the Channel Move Time and the Channel Closing Transmission Time begins is as follows:</p> <ul style="list-style-type: none"> <li>• For the Short Pulse Radar Test Signals this instant is the end of the Burst.</li> <li>• For the Frequency Hopping radar Test Signal, this instant is the end of the last radar Burst generated.</li> <li>• For the Long Pulse Radar Test Signal this instant is the end of the 12 second period defining the Radar Waveform.</li> </ul> <p><b>Note 2:</b> The Channel Closing Transmission Time is comprised of 200 milliseconds starting at the beginning of the Channel Move Time plus any additional intermittent control signals required to facilitate a Channel move (an aggregate of 60 milliseconds) during the remainder of the 10 second period. The aggregate duration of control signals will not count quiet periods in between transmissions.</p> <p><b>Note 3:</b> During the U-NII Detection Bandwidth detection test, radar type 1 is used and for each frequency step the minimum percentage of detection is 90 percent. Measurements are performed with no data traffic.</p>	

## **PARAMETERS OF DFS TEST SIGNALS**

Step intervals of 0.1 microsecond for Pulse Width, 1 microsecond for PRI, 1 MHz for chirp width and 1 for the number of pulses will be utilized for the random determination of specific test waveforms.

**Table 6: Short Pulse Radar Test Waveforms.**

Radar Type	Pulse Width (µsec)	PRI (µsec)	Number of Pulses	Minimum Percentage of Successful Detection	Minimum Number of Trials
1	1	1428	18	60%	30
2	1-5	150-230	23-29	60%	30
3	6-10	200-500	16-18	60%	30
4	11-20	200-500	12-16	60%	30
Aggregate (Radar Types 1-4)				80%	120

**Table 7: Long Pulse Radar Test Waveform**

Radar Type	Pulse Width (µsec)	Chirp Width (MHz)	PRI (µsec)	Number of Pulses per Burst	Number of Bursts	Minimum Percentage of Successful Detection	Minimum Number of Trials
5	50-100	5-20	1000-2000	1-3	8-20	80%	30

**Table 8: Frequency Hopping Radar Test Waveform**

Radar Type	Pulse Width (µsec)	PRI (µsec)	Pulses per Hop	Hopping Rate (kHz)	Hopping Sequence Length (msec)	Minimum Percentage of Successful Detection	Minimum Number of Trials
6	1	333	9	0.333	300	70%	30

### 2.1.3 TEST INSTRUMENTS

**Table 9: Test instruments list.**

DESCRIPTION & MANUFACTURER	MODEL NO.	BRAND	CALIBRATED UNTIL
R&S Spectrum analyzer	FSP40	R&S	Aug. 15, 2007
Signal generator	8645A	Agilent	May. 26, 2008
Oscilloscope	TDS 5104	Tektronix	Apr. 05. 2007

### 2.1.4 DESCRIPTION OF SUPPORT UNITS

**Table 10: Support Unit information.**

No.	Product	Brand	Model No.	ID	Spec.
1	802.11a/b/g Access Point	Cisco	AIR-AP1242AG-A-K9	LDK102056	The maximum EIRP is 21.5 dBm, Antenna Gain is 3dBi

### 2.1.5 SOFTWARE AND FIRMWARE

**Table 11: The software/firmware version for U-NII device.**

No.	Product	Model No.	Software/Firmware Version
1	802.11a/b/g WLAN SDIO Radio Module	21-92955	Version 3.0.0.521
2	802.11a/b/g Access Point	AIR-AP1242AG-A-K9	C1240-K9W7-TAR.123-11.JA



## 2.1.6 DESCRIPTION OF AVAILABLE ANTENNAS

**Table 12: Antenna list.**

Ant NO.	Antenna	Type	Operation Frequency Range	Max. Gain(dBi)
1	DIPOLE,C802-510001-A	Dipole	5.15 – 5.85 GHz	2.8

## 2.1.7 MAXIMUM AND MINIMUM CONDUCTED POWER

**Table 13: The measured conducted output power.**

Ant NO.	Frequency Band(MHZ)	MAX. Power		MIN. Power	
		Output Power(dBm)	Output Power(mW)	Output Power(dBm)	Output Power(mW)
1	5250~5350MHz	15.42	34.8337315	5.91	3.899419867
1	5470~5725MHz	14.04	25.3512863	2.2	1.659586907

## 2.1.8 MAXIMUM AND MINIMUM E.I.R.P. POWER

**Table 14: The E.I.R.P output power list.**

Ant NO.	Frequency Band(MHZ)	MAX. Power		MIN. Power	
		Output Power(dBm)	Output Power(mW)	Output Power(dBm)	Output Power(mW)
1	5250~5350MHz	18.22	66.37430704	8.71	7.430191379
1	5470~5725MHz	16.84	48.3058802	5	3.16227766

### 2.1.9 STATEMENT OF MAUNFACTURER

Manufacturer statement confirming that information regarding the parameters of the detected Radar Waveforms is not available to the end user and the device doesn't have Ad Hoc mode on DFS frequency band.

### 2.1.10 TEST PROCEDURE

#### ADT DFS Measurement System:

A complete ADT DFS Measurement System consists of two subsystems: (1) the Radar Signal Generating Subsystem and (2) the Traffic Monitoring Subsystem. The control PC is necessary for generating the Radar waveforms in Table 6, 7 and 8. The traffic monitoring subsystem is specified to the type of unit under test (UUT).

#### Conducted setup configuration of ADT DFS Measurement System

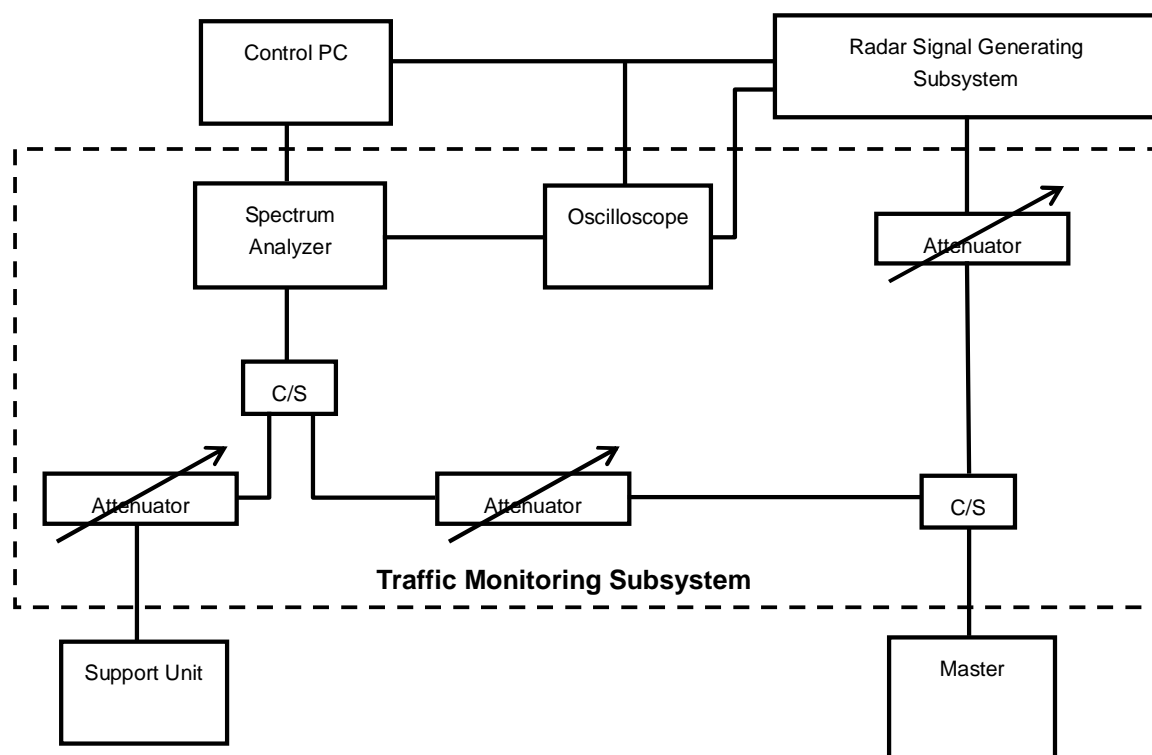

The test transmission will always be from the Master Device to the Client Device. While the Client device is set up to associate with the Master device and play the WAV file from Master device, the designated WAV test file and instructions are located at: <http://ntiacsd.ntia.doc.gov/dfs/>.

The test with WAV file, because MPEG2 file cannot be played with the EUT.

### Calibration of DFS Detection Threshold Level:

The measured channel is 5320MHz. The radar signal was the same as transmitted channels, and injected into the antenna port of AP (master), measured the channel closing transmission time and channel move time. The Required detection threshold is  $-58\text{dBm}$  ( $= -62 + 1 + 3$ )dBm. The calibrated conducted detection threshold level is set to  $-59\text{dBm}$ . The tested level is lower than required level hence it provides margin to the limit.

### Conducted setup configuration of Calibration of DFS Detection Threshold Level

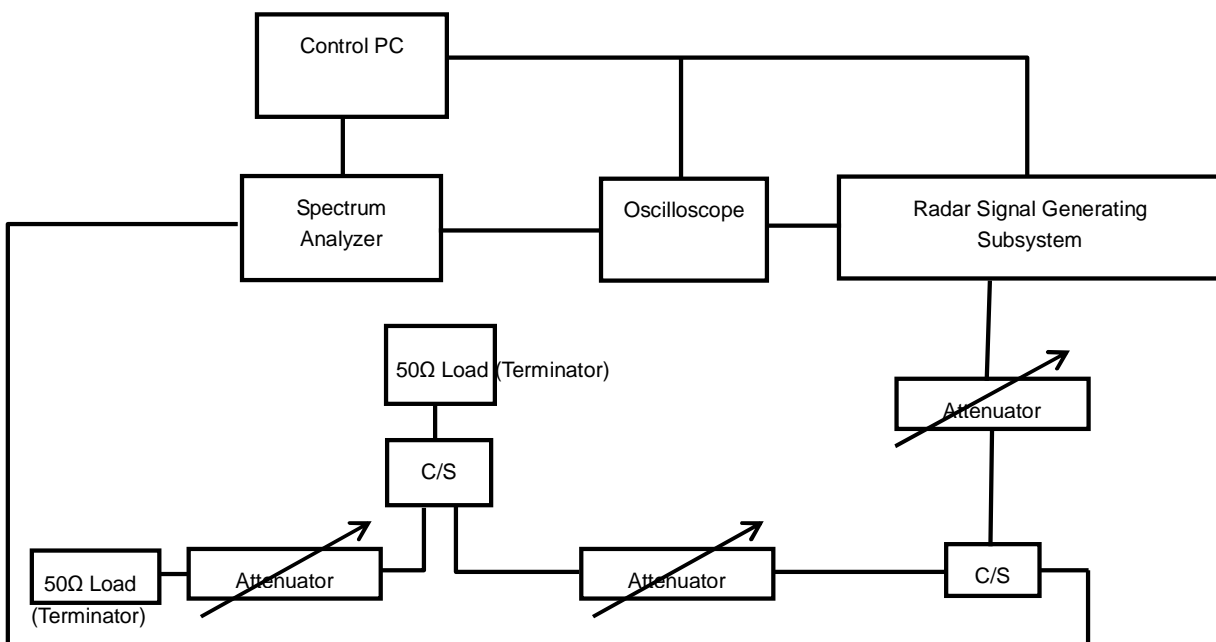

### 2.1.11 DEVIATION FROM TEST STANDARD

No deviation.

### 2.1.12 CONDUCTED TEST SETUP CONFIGURATION

#### Client without radar detection mode (Radar injected into Master)

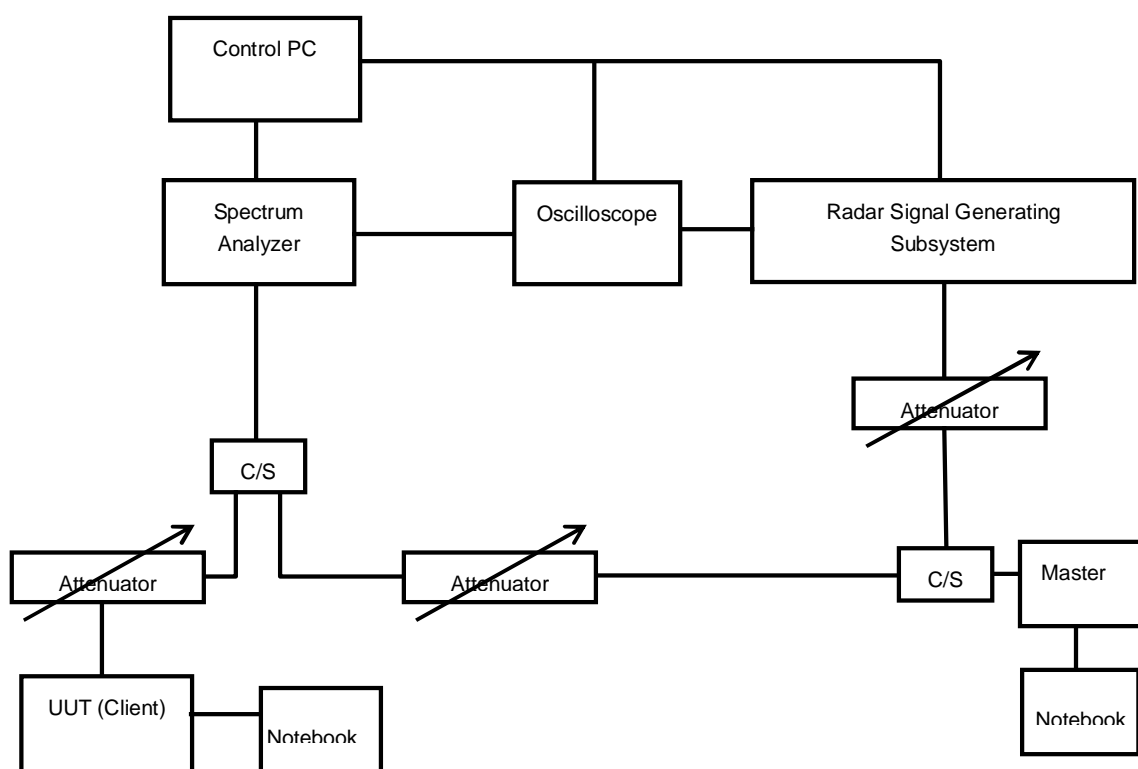

The UUT is a U-NII Device operating in Client mode with radar detection. The radar test signals are injected into the Master Device.

### 2.1.13 LIST OF MEASUREMENTS

**The UUT is capable of operating as a Client without radar detection.**

Clause	Test Parameter	Remarks	Pass/Fail
15.407	DFS Detection Threshold	Not Applicable	NA
15.407	Channel Availability Check Time	Not Applicable	NA
15.407	Channel Move Time	Applicable	Pass
15.407	Channel Closing Transmission Time	Applicable	Pass
15.407	Non- Occupancy Period	Not Applicable	NA
15.407	Uniform Spreading	Not Applicable	NA
15.407	U-NII Detection Bandwidth	Not Applicable	NA

## 2.1.14 TEST RESULTS

The UUT is a U-NII Device operating in Client without Radar Detection mode. The radar test signals are injected into the Master Device.

### 1. DFS DETECTION THRESHOLD

For a detection threshold level of  $-62\text{dBm}$  and the Master antenna gain is  $3\text{dBi}$ . The Required detection threshold is  $-58\text{dBm}$  ( $= -62 + 1 + 3$ ) $\text{dBm}$ . The conducted radar burst level is set to  $-59\text{dBm}$ . The tested level is lower than required level hence it provides margin to the limit.

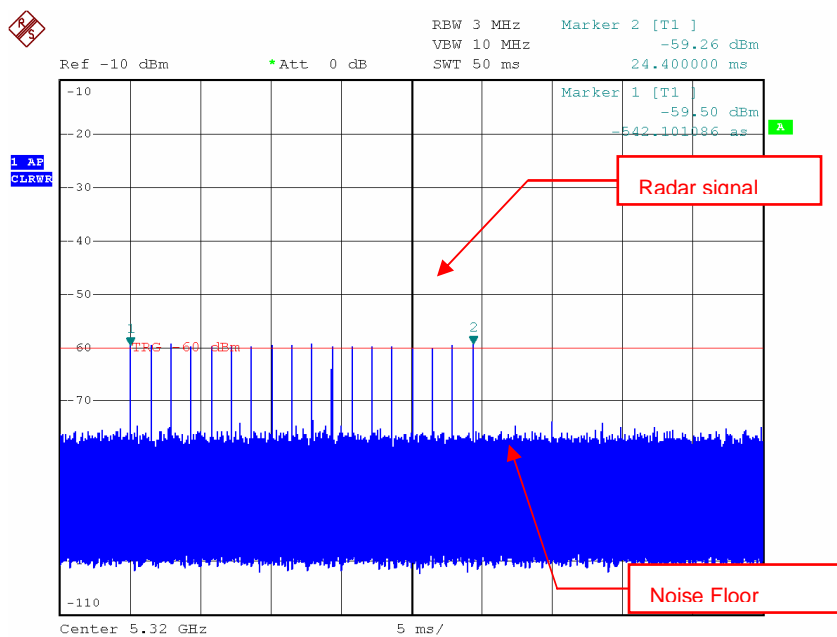

Date: 21.MAR.2007 02:15:56

Radar Signal 1

## 2. Channel Closing Transmission and Channel Move Time

Duty Cycle @ CH064 - 5320MHz

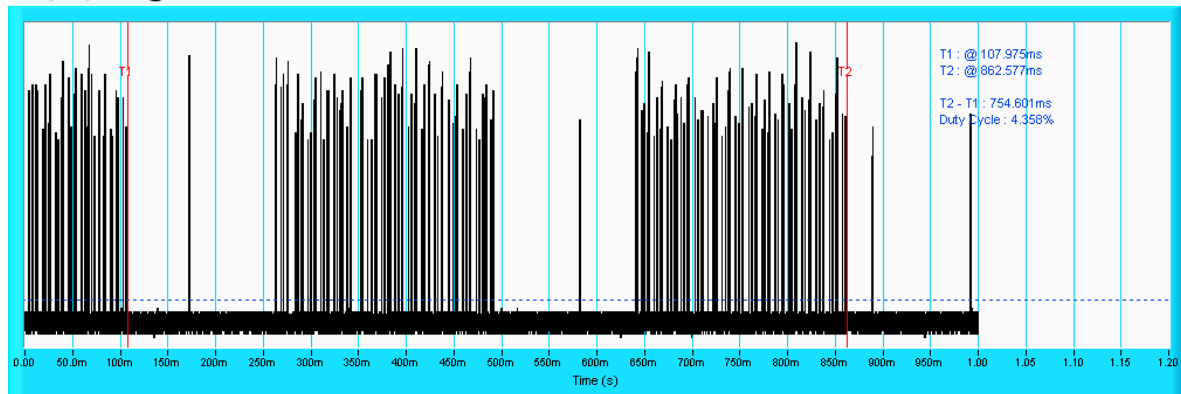

**NOTE:** T1 denotes the start of duty cycle period is 0.107975<sup>th</sup> second. T2 denotes the end of duty cycle period is 0.862577<sup>th</sup> second. T2 – T1= 0.754601 seconds. Duty Cycle = 4.358%

## Radar signal 1

### Channel Closing Transmission Time & Channel Move Time @ CH052 - 5260MHz

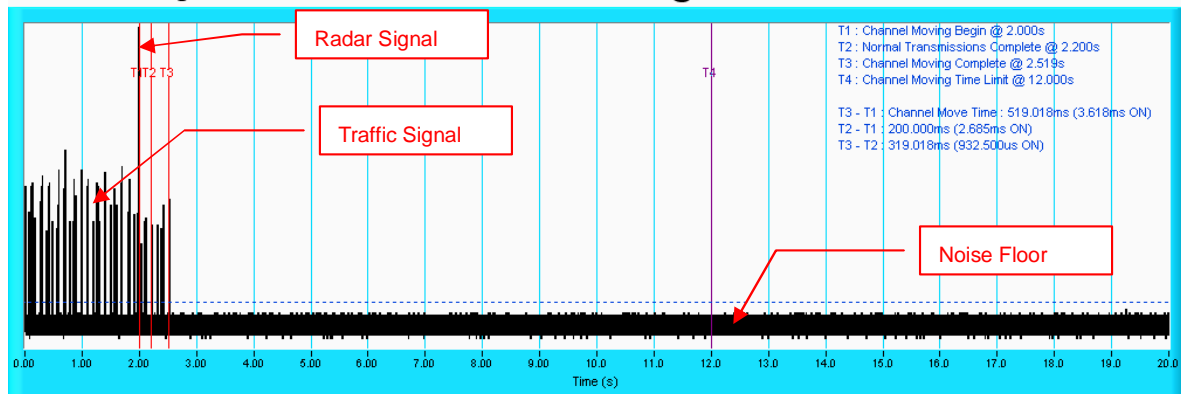

**NOTE:** T1 denotes the start of Channel Move Time upon the end of the last Radar burst. T2 denotes the data transmission time of 200ms from T1. T3 denotes the end of Channel Move Time. T4 denotes the 10 second from T1 to observe the aggregate duration of transmissions.

### Channel Closing Transmission Time & Channel Move Time @ CH052 - 5260MHz

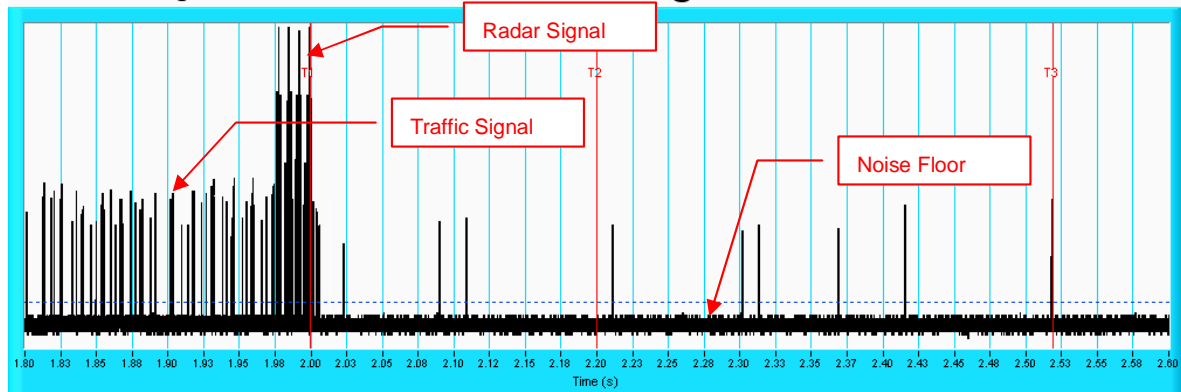

**NOTE:** An expanded plot for the device vacates the channel in the required 200ms.





Type 1 Radar Statistical Performances				
Trial #	Pulses per Burst	Pulse Width (s)	PRI (s)	Detection
1	18	1.0u	1.428m	Yes
2	18	1.0u	1.428m	Yes
3	18	1.0u	1.428m	Yes
4	18	1.0u	1.428m	Yes
5	18	1.0u	1.428m	Yes
6	18	1.0u	1.428m	Yes
7	18	1.0u	1.428m	Yes
8	18	1.0u	1.428m	Yes
9	18	1.0u	1.428m	Yes
10	18	1.0u	1.428m	Yes
11	18	1.0u	1.428m	Yes
12	18	1.0u	1.428m	Yes
13	18	1.0u	1.428m	Yes
14	18	1.0u	1.428m	Yes
15	18	1.0u	1.428m	Yes
16	18	1.0u	1.428m	Yes
17	18	1.0u	1.428m	Yes
18	18	1.0u	1.428m	Yes
19	18	1.0u	1.428m	Yes
20	18	1.0u	1.428m	Yes
21	18	1.0u	1.428m	Yes
22	18	1.0u	1.428m	Yes
23	18	1.0u	1.428m	Yes
24	18	1.0u	1.428m	Yes
25	18	1.0u	1.428m	Yes
26	18	1.0u	1.428m	Yes
27	18	1.0u	1.428m	Yes
28	18	1.0u	1.428m	Yes
29	18	1.0u	1.428m	Yes
30	18	1.0u	1.428m	Yes
				Detection Rate: 100 %



## **2.2 ANTENNA REQUIREMENT**

### **2.2.1 STANDARD APPLICABLE**

For intentional device, according to FCC 47 CFR Section 15.203, an intentional radiator shall be designed to ensure that no antenna other than that furnished by the responsible party shall be used with the device.

And according to FCC 47 CFR Section 15.407(a), if transmitting antennas of directional gain greater than 6dBi are used, the power shall be reduced by the amount in dB that the directional gain of the antenna exceeds 6dBi.

### **2.2.2 ANTENNA CONNECTED CONSTRUCTION**

The antenna used in this product is dipole antenna with RP-SMA MALE connector. The maximum Gain of the antenna is 2.8dBi.



### 3 INFORMATION ON THE TESTING LABORATORIES

We, ADT Corp., were founded in 1988 to provide our best service in EMC, Radio, Telecom and Safety consultation. Our laboratories are accredited and approved by the following approval agencies according to ISO/IEC 17025.

<b>USA</b>	FCC, UL, A2LA
<b>Germany</b>	TUV Rheinland
<b>Japan</b>	VCCI
<b>Norway</b>	NEMKO
<b>Canada</b>	INDUSTRY CANADA , CSA
<b>R.O.C.</b>	CNLA, BSMI, NCC
<b>Netherlands</b>	Telefication
<b>Singapore</b>	PSB , GOST-ASIA(MOU)
<b>Russia</b>	CERTIS(MOU)

Copies of accreditation certificates of our laboratories obtained from approval agencies can be downloaded from our web site:

[www.adt.com.tw/index.5/phtml](http://www.adt.com.tw/index.5/phtml). If you have any comments, please feel free to contact us at the following:

**Linko EMC/RF Lab:**

Tel: 886-2-26052180

Fax: 886-2-26051924

**Hsin Chu EMC/RF Lab:**

Tel: 886-3-5935343

Fax: 886-3-5935342

**Hwa Ya EMC/RF/Safety Telecom Lab:**

Tel: 886-3-3183232

Fax: 886-3-3185050

**Web Site:** [www.adt.com.tw](http://www.adt.com.tw)

The address and road map of all our labs can be found in our web site also.



## **APPENDIX-A**

### **MODIFICATIONS RECORDERS FOR ENGINEERING CHANGES TO THE EUT BY THE LAB**

No any modifications are made to the EUT by the lab during the test.