



FCC TEST REPORT (15.407)

REPORT NO.: RF940816H03D-3

MODEL NO.: AP-5131

RECEIVED: Jan. 06, 2010

TESTED: Apr. 16 to 19, 2010

ISSUED: Apr. 23, 2010

APPLICANT: Symbol Technologies Inc.

ADDRESS: One Symbol Plaza, Holtsville, NY 11742-1300 U.S.A.

ISSUED BY: Bureau Veritas Consumer Products Services (H.K.) Ltd., Taoyuan Branch Hsin Chu Laboratory

ADDRESS: No. 81-1, Lu Liao Keng, 9th Ling, Wu Lung Tsuen, Chiung Lin Hsiang, Hsin Chu Hsien 307, Taiwan

This test report consists of 33 pages in total. It may be duplicated completely for legal use with the approval of the applicant. It should not be reproduced except in full, without the written approval of our laboratory. The client should not use it to claim product endorsement by TAF or any government agencies. The test results in the report only apply to the tested sample.





A D T

Table of Contents

1.	CERTIFICATION	3
2.	SUMMARY OF TEST RESULTS	4
2.1	MEASUREMENT UNCERTAINTY	5
3.	GENERAL INFORMATION	6
3.1	GENERAL DESCRIPTION OF EUT	6
3.2	DESCRIPTION OF TEST MODES	9
3.2.1	TEST MODE APPLICABILITY AND TESTED CHANNEL DETAIL:	10
3.3	GENERAL DESCRIPTION OF APPLIED STANDARDS	12
3.4	DESCRIPTION OF SUPPORT UNITS.....	13
3.5	CONFIGURATION OF SYSTEM UNDER TEST	14
4.	TEST TYPES AND RESULTS	15
4.1	RADIATED EMISSION MEASUREMENT	15
4.1.1	LIMITS OF RADIATED EMISSION MEASUREMENT.....	15
4.1.2	LIMITS OF UNWANTED EMISSION OUT OF THE RESTRICTED BANDS.....	16
4.1.3	TEST INSTRUMENTS	17
4.1.4	TEST PROCEDURES.....	19
4.1.5	DEVIATION FROM TEST STANDARD	19
4.1.6	TEST SETUP	20
4.1.7	EUT OPERATING CONDITION	20
4.1.8	TEST RESULTS.....	21
4.2	PEAK TRANSMIT POWER MEASUREMENT.....	29
4.2.1	LIMITS OF PEAK TRANSMIT POWER MEASUREMENT	29
4.2.2	TEST INSTRUMENTS	29
4.2.3	TEST PROCEDURE	30
4.2.4	DEVIATION FROM TEST STANDARD	30
4.2.5	TEST SETUP	30
4.2.6	EUT OPERATING CONDITIONS	30
4.2.7	TEST RESULTS.....	31
5.	INFORMATION ON THE TESTING LABORATORIES	32
6.	APPENDIX-A- MODIFICATIONS RECORDERS FOR ENGINEERING CHANGES TO THE EUT BY THE LAB.....	33



1. CERTIFICATION

PRODUCT: Symbol WLAN 802.11abg Access Point
BRAND NAME: Symbol
MODEL NO.: AP-5131
PART NO.: AP-5131-40000-WW
TEST SAMPLE: ENGINEERING SAMPLE
TESTED: Apr. 16 to 19, 2010
APPLICANT: Symbol Technologies Inc.
STANDARDS: FCC Part 15, Subpart E (Section 15.407),
ANSI C63.4-2003

The above equipment (Model: AP-5131) has been tested by **Bureau Veritas Consumer Products Services (H.K.) Ltd., Taoyuan Branch**, and found compliance with the requirement of the above standards. The test record, data evaluation & Equipment Under Test (EUT) configurations represented herein are true and accurate accounts of the measurements of the sample's EMC characteristics under the conditions specified in this report.

PREPARED BY : Carol Liao , **DATE:** Apr. 23, 2010
(Carol Liao, Specialist)

TECHNICAL ACCEPTANCE : Hank Chung , **DATE:** Apr. 23, 2010
(Hank Chung, Deputy Manager)

APPROVED BY : May Chen , **DATE:** Apr. 23, 2010
(May Chen, Deputy Manager)

2. SUMMARY OF TEST RESULTS

The EUT has been tested according to the following specifications:

For 802.11a

APPLIED STANDARD: FCC Part 15, Subpart E (Section 15.407)			
Standard Section	Test Type	Result	Remark
15.407(b/1/2/3) (b)(5)	Electric Field Strength Spurious Emissions, 30MHz ~ 40000MHz	PASS	Meet the requirement of limit. Minimum passing margin is -6.1dB at 5350.0MHz
15.407(a/1/2/3)	Peak Transmit Power	PASS	Meet the requirement of limit.
15.203	Antenna Requirement	PASS	Antenna connector is not a standard connector. (Pls. also refer to 3.1 note 1)

NOTE:

1. The EUT was operating in 2400 ~ 2483.5MHz, 5.15~5.25GHz and 5.725~5.850GHz frequencies band. This report was recorded the RF parameters including 5.15~5.25GHz. For the 2400 ~ 2483.5MHz and 5.725~5.850GHz RF parameters was recorded in another test report.
2. This report is prepared for FCC class II permissive change. Only radiated emission and maximum peak output power were presented in this test report.

2.1 MEASUREMENT UNCERTAINTY

Where relevant, the following measurement uncertainty levels have been estimated for tests performed on the EUT as specified in CISPR 16-4-2:

This uncertainty represents an expanded uncertainty expressed at approximately the 95% confidence level using a coverage factor of $k=2$.

Measurement	Value
Radiated emissions (30MHz-1GHz)	3.7 dB
Radiated emissions (1GHz -18GHz)	2.49 dB
Radiated emissions (18GHz -40GHz)	2.70 dB



A D T

3. GENERAL INFORMATION

3.1 GENERAL DESCRIPTION OF EUT

PRODUCT	Symbol WLAN 802.11abg Access Point
MODEL NO.	AP-5131
FCC ID	H9PAP5131S
POWER SUPPLY	DC 48V from or POE (Power over Ethernet)
MODULATION TYPE	CCK, DQPSK, DBPSK for DSSS 64QAM, 16QAM, QPSK, BPSK for OFDM
MODULATION TECHNOLOGY	DSSS, OFDM
TRANSFER RATE	802.11b:11/5.5/2/1Mbps 802.11g: 54/48/36/24/18/12/9/6Mbps 802.11a: 54/48/36/24/18/12/9/6Mbps
FREQUENCY RANGE	For 15.407 802.11a: 5.18 ~ 5.24GHz
	For 15.247 802.11b & 802.11g: 2412 ~ 2462MHz 802.11a: 5.745 ~ 5.825GHz
NUMBER OF CHANNEL	For 15.407 4 for 802.11a
	For 15.247(2.4GHz) 11 for 802.11b, 802.11g
	For 15.247(5GHz) 5 for 802.11a
MAXIMUM OUTPUT POWER	For 15.407 802.11a: 7.8mW
	For 15.247(2.4GHz) 802.11g: 144.5mW
	For 15.247(5GHz) 802.11a: 74.1mW
ANTENNA TYPE	Please see note 2
ANTENNA CONNECTOR	Please see note 2
DATA CABLE	NA
I/O PORTS	Console Port x1, LAN Port x1, WAN Port x1
ASSOCIATED DEVICES	POE x 1



A D T

NOTE:

1. This report is prepared for FCC class II permissive change. The difference compared with the Report No.: RF940816H03 design is as the following:

- u Substitution of Diplexer part: NTK LDG0UQD-3092A with Soshin HMD881J. Applicant has submitted a parts comparison analysis and believe they are electrical identical and hence only worst case antenna from previous certified list was selected for the radiated emission test.
- u Remove the DFS band<5250~5350MHz> & FCC Part 15E 5.7G band<5.745 ~ 5.805GHz>
- u Change the arrester
- u Change POE

2. There are six antennas provided to this EUT, please refer to the following table:

For 2.4GHz							
No.	Symbol P/N	Gain (dBi)	Cable Loss (dB)	Net Gain (dB)	Antenna Type	Connector	Remark
1	*ML-2452-APA2-01	3.0	0	3.0	Dipole	RP SMA	Omni
2	ML-2499-11PNA2-01	11.2	2.7	8.5	Panel	Reverse BNC	Directional
3	ML-2499-HPA3-01	4.6	1.3	3.3	Dipole	Reverse BNC	Omni
4	**ML-2499-BYGA2-01	14.2	0.3	13.9	Yagi	RP SMA	Directional
For 5GHz							
No.	Symbol P/N	Gain (dBi)	Cable Loss (dB)	Net Gain (dB)	Antenna Type	Connector	Remark
1	*ML-2452-APA2-01	4.0	0	4.0	Dipole	RP SMA	Omni
2	ML-5299-WPNA1-01	14.2	1.2	13.0	Patch	RP SMA	Directional
3	ML-5299-HPA1-01	5.9	0.84	5.0	Omni	RP SMA	Omni

Note:

1. All of the above antennas are Indoor Antenna except the Symbol P/N: ML-2499-BYGA2-01.
2. “**” is a Dual Band antenna can be used in both 2.4GHz and 5GHz.
3. “***” is an Outdoor Antenna it can only be used in point-to-point applications.
4. For 2.4GHz Antenna No. 2 and 3 have Extend cable (0.5 dB loss).
5. For 2.4GHz Antenna No. 4 has Extend cable (0.5 dB loss) and Arrester (1.0 dB loss).

From the above modes, **Antenna 2** was chosen for final test.

3. According to client’s declaration letter which declares diplexer characteristic is same as the original application, there is worst case antenna has to be performed. . And all data was verified to meet the requirements.
4. The EUT operates in both the 5GHz and 2.4GHz Bands and compatibility with 802.11a and 802.11b, 802.11g technology.

5. The EUT must be supplied with a POE:

BRAND:	PowerDsine
MODEL:	3001GB/AC
INPUT:	AC100-250V, 0.5A, 50-60Hz
OUTPUT:	DC 48V, 0.35 A

6. The above EUT information was declared by the manufacturer and for more detailed features description, please refer to the manufacturer's specifications or User's Manual.



A D T

3.2 DESCRIPTION OF TEST MODES

Four channels are provided for 802.11a:

Channel	Frequency
36	5180 MHz
40	5200 MHz
44	5220 MHz
48	5240 MHz



A D T

3.2.1 TEST MODE APPLICABILITY AND TESTED CHANNEL DETAIL:

EUT CONFIGURE MODE	APPLICABLE TO				DESCRIPTION
	PLC	RE < 1G	RE ≥ 1G	APCM	
-	-	√	√	√	-

Where **PLC**: Power Line Conducted Emission **RE < 1G**: Radiated Emission below 1GHz
RE ≥ 1G: Radiated Emission above 1GHz **APCM**: Antenna Port Conducted Measurement

RADIATED EMISSION TEST (BELOW 1 GHz):

- Pre-Scan has been conducted to determine the worst-case mode from all possible combinations between available modulations, data rates and antenna ports (if EUT with antenna diversity architecture).
- Following channel(s) was (were) selected for the final test as listed below.

MODE	AVAILABLE CHANNEL	TESTED CHANNEL	MODULATION TECHNOLOGY	MODULATION TYPE	DATA RATE (Mbps)
802.11a	36 to 48	40	OFDM	BPSK	6

RADIATED EMISSION TEST (ABOVE 1 GHz):

- Pre-Scan has been conducted to determine the worst-case mode from all possible combinations between available modulations, data rates and antenna ports (if EUT with antenna diversity architecture).
- Following channel(s) was (were) selected for the final test as listed below.

MODE	AVAILABLE CHANNEL	TESTED CHANNEL	MODULATION TECHNOLOGY	MODULATION TYPE	DATA RATE (Mbps)
802.11a	36 to 48	36, 40, 48	OFDM	BPSK	6

ANTENNA PORT CONDUCTED MEASUREMENT:

- This item includes all test value of each mode, but only includes spectrum plot of worst value of each mode.
- Pre-Scan has been conducted to determine the worst-case mode from all possible combinations between available modulations, data rates and antenna ports (if EUT with antenna diversity architecture).
- Following channel(s) was (were) selected for the final test as listed below.

MODE	AVAILABLE CHANNEL	TESTED CHANNEL	MODULATION TECHNOLOGY	MODULATION TYPE	DATA RATE (Mbps)
802.11a	36 to 48	36, 40, 48	OFDM	BPSK	6

TEST CONDITION:

APPLICABLE TO	ENVIRONMENTAL CONDITIONS	INPUT POWER	TESTED BY
RE ³ 1G	20deg. C, 72%RH, 1013 hPa	120Vac, 60Hz	Phoenix Huang
RE<1G	24deg. C, 61%RH, 1013 hPa	120Vac, 60Hz	Kevin Huang
APCM	25deg. C, 60%RH, 1013 hPa	120Vac, 60Hz	Phoenix Huang



3.3 GENERAL DESCRIPTION OF APPLIED STANDARDS

The EUT is a Symbol WLAN 802.11abg Access Point. According to the specifications of the manufacturer, it must comply with the requirements of the following standards:

FCC Part 15, Subpart E (15.407)

ANSI C63.4-2003

All test items have been performed and recorded as per the above standards.

NOTE: The EUT has been verified to comply with the requirements of FCC Part 15, Subpart B, Class B (DoC). The test report has been issued separately.



A D T

3.4 DESCRIPTION OF SUPPORT UNITS

The EUT has been tested as an independent unit together with other necessary accessories or support units. The following support units or accessories were used to form a representative test configuration during the tests.

NO.	PRODUCT	BRAND	MODEL NO.	SERIAL NO.	FCC ID
1	NOTEBOOK COMPUTER	DELL	PP01L	TW-09c748-12800 -165-3171	FCC DoC
2	NOTEBOOK COMPUTER	DELL	PP01L	TW-0791UH-1280 0-0CK-3735	FCC DoC
3	NOTEBOOK COMPUTER	DELL	PP05L	CN-04Y212-48643 -38E-0145	NA

NO.	SIGNAL CABLE DESCRIPTION OF THE ABOVE SUPPORT UNITS
1	UTP Cable (10m)
2	UTP Cable (0.3m)
3	NA

NOTE: All power cords of the above support units are non shielded (1.8m).

3.5 CONFIGURATION OF SYSTEM UNDER TEST

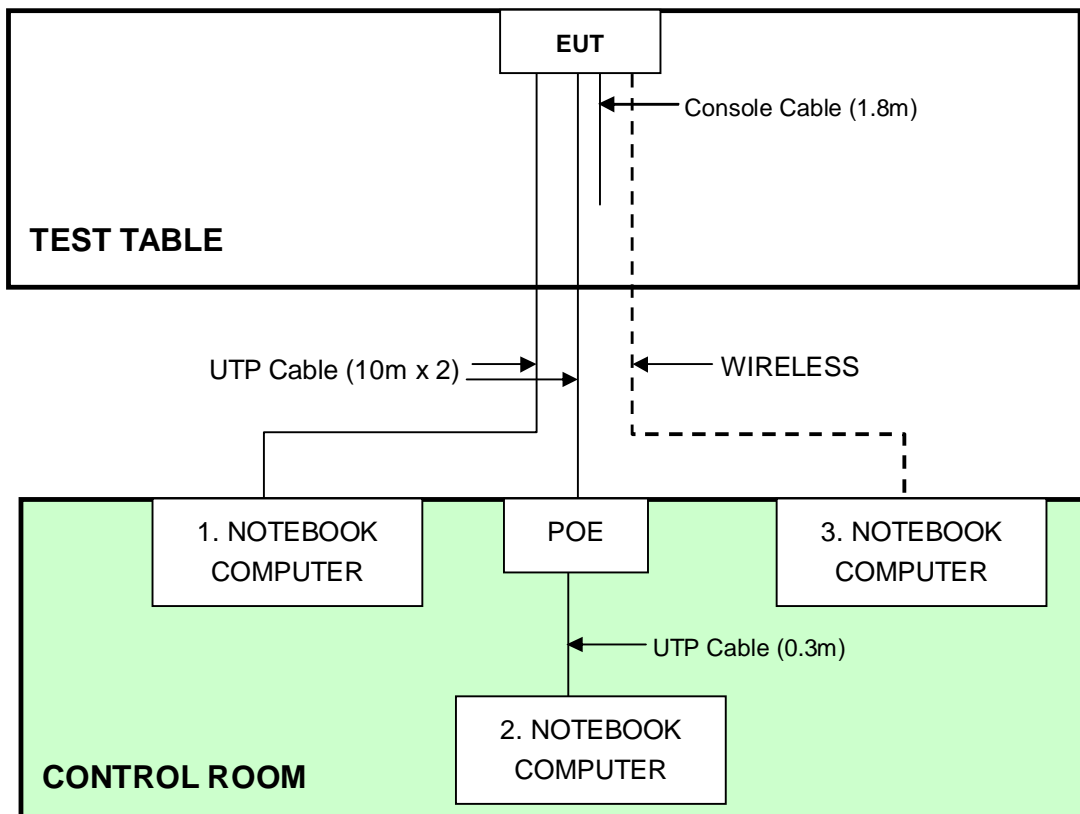

NOTE: 1. Support unit 1~3 were kept in the control room during the test.

4. TEST TYPES AND RESULTS

4.1 RADIATED EMISSION MEASUREMENT

4.1.1 LIMITS OF RADIATED EMISSION MEASUREMENT

Emissions radiated outside of the specified bands, shall be according to the general radiated limits in 15.209 as following:

Frequencies (MHz)	Field strength (microvolts/meter)	Measurement distance (meters)
0.009-0.490	2400/F(kHz)	300
0.490-1.705	24000/F(kHz)	30
1.705-30.0	30	30
30-88	100	3
88-216	150	3
216-960	200	3
Above 960	500	3

NOTE:

1. The lower limit shall apply at the transition frequencies.
2. Emission level (dBuV/m) = 20 log Emission level (uV/m).
3. As shown in 15.35(b), for frequencies above 1000MHz, the field strength limits are based on average detector, however, the peak field strength of any emission shall not exceed the maximum permitted average limits, specified above by more than 20dB under any condition of modulation.

4.1.2 LIMITS OF UNWANTED EMISSION OUT OF THE RESTRICTED BANDS

Frequencies (MHz)	EIRP Limit (dBm)	Equivalent Field Strength at 3m (dBµV/m) *note 3
5150~5250	-27	68.3
5250~5350	-27	68.3
5470~5725	-27	68.3
5725~5825	-27 *note 1	68.3
	-17 *note 2	78.3

NOTE:

1. For frequencies 10MHz or greater above or below the band edge.
2. All emissions within the frequency range from the band edge to 10MHz above or below the band edge.
3. The following formula is used to convert the equipment isotropic radiated power (eirp) to field strength

$$E = \frac{1000000\sqrt{30P}}{3} \mu\text{V/m, where P is the eirp (Watts)}$$



A D T

4.1.3 TEST INSTRUMENTS

Below 1GHz test :

DESCRIPTION & MANUFACTURER	MODEL NO.	SERIAL NO.	CALIBRATED DATE	CALIBRATED UNTIL
ADVANTEST Spectrum Analyzer	U3751	170100022	Nov. 18, 2009	Nov. 17, 2010
ADVANTEST Spectrum Analyzer	U3772	160100280	Sep. 21, 2009	Sep. 20, 2010
HP Pre_Amplifier	8449B	3008A01922	Sep. 25, 2009	Sep. 24, 2010
ROHDE & SCHWARZ Test Receiver	ESCS 30	100027	May 05, 2009	May 04, 2010
SCHWARZBECK Broadband Antenna	VULB-9168	263	Apr. 29, 2009	Apr. 28, 2010
Schwarzbeck Horn_Antenna	BBHA9120	D123	Sep. 21, 2009	Sep. 20, 2010
Schwarzbeck Horn_Antenna	BBHA 9170	BBHA9170153	Jan. 23, 2010	Jan. 22, 2011
RF Switches	EM-H-01-1	1009	Aug. 10, 2009	Aug. 08, 2010
RF Cable	8DFB	STACAB-30M-1GHz-091	Nov. 20, 2009	Nov. 19, 2010
Software	ADT_Radiated_V7.6.15.9.2	NA	NA	NA
CT Antenna Tower & Turn Table	TT100	ADT01	NA	NA
CORCOM AC Filter	MRI2030	107/108	NA	NA

Note: 1. The calibration interval of the above test instruments is 12 months and the calibrations are traceable to NML/ROC and NIST/USA.

2. The horn antenna, HP preamplifier (model: 8449B) and Spectrum Analyzer (model: U3772) are used only for the measurement of emission frequency above 1GHz if tested.
3. The test was performed in Open Site No. A.
4. The VCCI Site Registration No. is R-782.
5. The FCC Site Registration No. is 91097.
6. The CANADA Site Registration No. is IC 7450G-1.



A D T

Above 1GHz test :

DESCRIPTION & MANUFACTURER	MODEL NO.	SERIAL NO.	CALIBRATED DATE	CALIBRATED UNTIL
ROHDE & SCHWARZ Spectrum Analyzer	FSP40	100036	Dec. 18, 2009	Dec. 17, 2010
Agilent PSA Spectrum Analyzer	E4446A	MY46180622	Apr. 24 , 2009	Apr. 23 , 2010
HP Pre_Amplifier	8449B	300801923	Nov. 02, 2009	Nov. 01, 2010
ROHDE & SCHWARZ Test Receiver	ESCS30	847124/029	Aug. 28, 2009	Aug. 27, 2010
SCHWARZBECK TRILOG Broadband Antenna	VULB 9168	138	Apr. 29, 2009	Apr. 28, 2010
Schwarzbeck Horn_Antenna	BBHA9120	D124	Dec. 18, 2009	Dec. 17, 2010
Schwarzbeck Horn_Antenna	BBHA 9170	BBHA9170153	Jan. 22, 2010	Jan. 21, 2011
R&S Loop Antenna	HFH2-Z2	100070	Feb. 3, 2010	Feb. 2, 2012
RF Switches	EMH-011	1001	NA	NA
RF CABLE (Chaintek)	Sucoflex 106	28077	Aug. 14, 2009	Aug. 13, 2010
RF Cable	8DFB	STCCAB-30M-1GHz	NA	NA
Software	ADT_Radiated_V7.6.15.9.2	NA	NA	NA
CT Antenna Tower & Turn Table	NA	NA	NA	NA

Note: 1. The calibration interval of the above test instruments is 12 months and the calibrations are traceable to NML/ROC and NIST/USA.

2. The horn antenna, HP preamplifier (model: 8449B) and Spectrum Analyzer (model: FSP40) are used only for the measurement of emission frequency above 1GHz if tested.

3. The test was performed in Open Site No. C.

4. The FCC Site Registration No. is 656396.

5. The VCCI Site Registration No. is R-1626.

6. The CANADA Site Registration No. is IC 7450G-3.

4.1.4 TEST PROCEDURES

- a. The EUT was placed on the top of a rotating table 0.8 meters above the ground at a 10 meter open area test site. The table was rotated 360 degrees to determine the position of the highest radiation.
- b. The EUT was set 3 meters away from the interference-receiving antenna, which was mounted on the top of a variable-height antenna tower.
- c. The antenna is a broadband antenna, and its height is varied from one meter to four meters above the ground to determine the maximum value of the field strength. Both horizontal and vertical polarizations of the antenna are set to make the measurement.
- d. For each suspected emission, the EUT was arranged to its worst case and then the antenna was tuned to heights from 1 meter to 4 meters and the rotatable table was turned from 0 degrees to 360 degrees to find the maximum reading.
- e. The test-receiver system was set to Peak Detect Function and Specified Bandwidth with Maximum Hold Mode.
- f. If the emission level of the EUT in peak mode was 10dB lower than the limit specified, then testing could be stopped and the peak values of the EUT would be reported. Otherwise the emissions that did not have 10dB margin would be re-tested one by one using peak, quasi-peak or average method as specified and then reported in a data sheet.

NOTE:

1. The resolution bandwidth and video bandwidth of test receiver/spectrum analyzer is 120kHz for Peak detection (PK) and Quasi-peak detection (QP) at frequency below 1GHz.
2. The resolution bandwidth of test receiver/spectrum analyzer is 1 MHz and the video bandwidth is 3 MHz for Peak detection (PK) at frequency above 1GHz.
3. The resolution bandwidth of test receiver/spectrum analyzer is 1 MHz and the video bandwidth is 10 Hz for Average detection (AV) at frequency above 1GHz.

4.1.5 DEVIATION FROM TEST STANDARD

No deviation

4.1.6 TEST SETUP

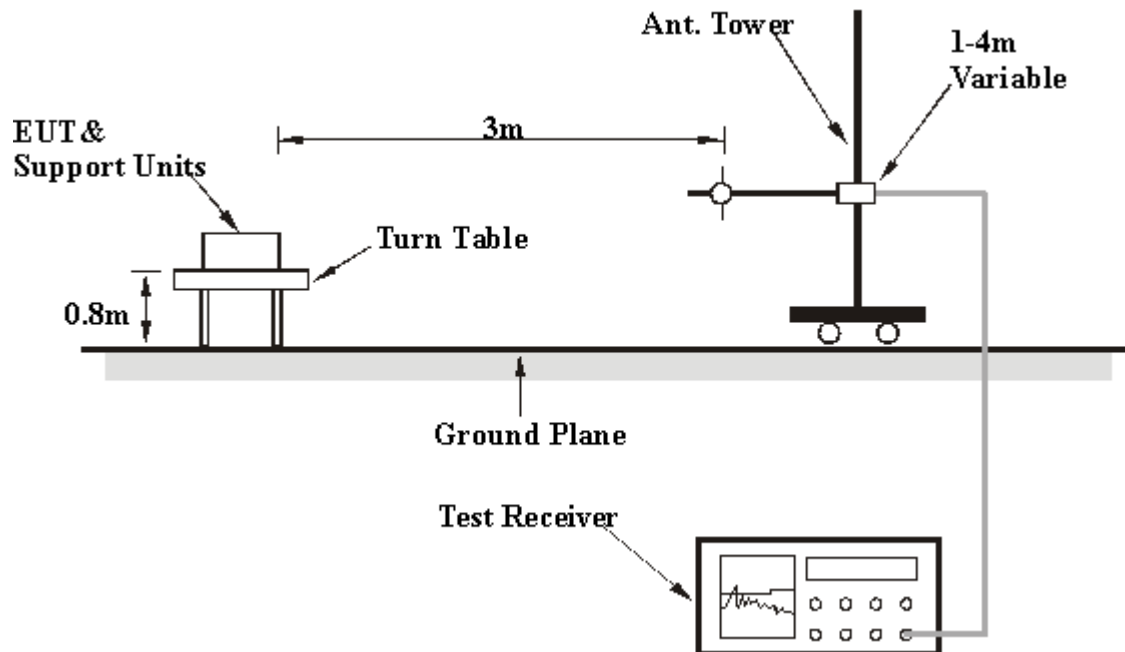

For the actual test configuration, please refer to the related item – Photographs of the Test Configuration.

4.1.7 EUT OPERATING CONDITION

1. Placed the EUT on the testing table.
2. Prepared other computer systems to act as a communication partner and placed them outside of testing area.
3. The communication partner run test program “Wintrion V00.02” to enable EUT under transmission/receiving condition continuously at specific channel frequency via UTP cables and wireless.



A D T

4.1.8 TEST RESULTS

BELOW 1GHz WORST-CASE DATA : 802.11a OFDM MODULATION

EUT TEST CONDITION		MEASUREMENT DETAIL	
CHANNEL	Channel 40	FREQUENCY RANGE	Below 1000MHz
INPUT POWER	120Vac, 60 Hz	DETECTOR FUNCTION	Quasi-Peak
ENVIRONMENTAL CONDITIONS	24deg. C, 61%RH 1013 hPa	TESTED BY	Kevin Huang

ANTENNA POLARITY & TEST DISTANCE: HORIZONTAL AT 3 M								
NO.	FREQ. (MHz)	EMISSION LEVEL (dBuV/m)	LIMIT (dBuV/m)	MARGIN (dB)	ANTENNA HEIGHT (m)	TABLE ANGLE (Degree)	RAW VALUE (dBuV)	CORRECTION FACTOR (dB/m)
1	125.04	31.6 QP	43.5	-11.9	1.00 H	154	18.78	12.84
2	200.02	33.3 QP	43.5	-10.2	2.24 H	132	21.58	11.72
3	250.00	33.1 QP	46.0	-12.9	1.52 H	121	19.45	13.67
4	440.05	37.4 QP	46.0	-8.6	2.11 H	244	17.76	19.60
5	480.00	37.0 QP	46.0	-9.0	2.06 H	175	16.27	20.74
6	499.99	34.9 QP	46.0	-11.1	2.57 H	122	13.57	21.31
7	520.00	35.7 QP	46.0	-10.3	1.00 H	195	14.00	21.74
8	624.99	33.9 QP	46.0	-12.1	1.00 H	287	10.05	23.85
9	875.01	35.2 QP	46.0	-10.8	1.00 H	225	7.36	27.81
10	999.99	43.8 QP	54.0	-10.2	1.00 H	100	14.58	29.21
ANTENNA POLARITY & TEST DISTANCE: VERTICAL AT 3 M								
NO.	FREQ. (MHz)	EMISSION LEVEL (dBuV/m)	LIMIT (dBuV/m)	MARGIN (dB)	ANTENNA HEIGHT (m)	TABLE ANGLE (Degree)	RAW VALUE (dBuV)	CORRECTION FACTOR (dB/m)
1	64.22	27.8 QP	40.0	-12.2	1.00 V	102	14.76	13.02
2	125.00	33.8 QP	43.5	-9.8	1.00 V	114	20.91	12.83
3	250.02	35.1 QP	46.0	-10.9	1.24 V	184	21.47	13.67
4	398.41	33.1 QP	46.0	-13.0	1.40 V	168	14.63	18.42
5	480.00	35.8 QP	46.0	-10.2	1.23 V	174	15.04	20.74
6	500.01	34.8 QP	46.0	-11.2	1.38 V	105	13.47	21.31
7	520.03	36.6 QP	46.0	-9.4	2.06 V	170	14.87	21.74
8	625.01	35.5 QP	46.0	-10.5	2.55 V	112	11.62	23.85
9	875.02	34.3 QP	46.0	-11.7	1.55 V	261	6.53	27.81
10	1000.00	41.7 QP	54.0	-12.3	1.52 V	305	12.53	29.21

- REMARKS:**
1. Emission level (dBuV/m) = Raw Value (dBuV) + Correction Factor (dB/m).
 2. Correction Factor (dB/m) = Antenna Factor (dB/m) + Cable Factor (dB).
 3. The other emission levels were very low against the limit.
 4. Margin value = Emission level – Limit value.



A D T

ABOVE 1GHz WORST-CASE DATA

802.11a OFDM MODULATION

EUT TEST CONDITION		MEASUREMENT DETAIL	
CHANNEL	Channel 36	FREQUENCY RANGE	1 ~ 40GHz
INPUT POWER	120Vac, 60 Hz	DETECTOR FUNCTION	Peak (PK) Average (AV)
ENVIRONMENTAL CONDITIONS	20deg. C, 72%RH 1013 hPa	TESTED BY	Phoenix Huang

ANTENNA POLARITY & TEST DISTANCE: HORIZONTAL AT 3 M								
NO.	FREQ. (MHz)	EMISSION LEVEL (dBuV/m)	LIMIT (dBuV/m)	MARGIN (dB)	ANTENNA HEIGHT (m)	TABLE ANGLE (Degree)	RAW VALUE (dBuV)	CORRECTION FACTOR (dB/m)
1	5143.50	53.1 PK	74.0	-20.9	1.41 H	331	17.14	35.99
2	5143.50	40.8 AV	54.0	-13.3	1.41 H	331	4.76	35.99
3	*5180.00	92.2 PK			1.41 H	331	56.15	36.05
4	*5180.00	83.2 AV			1.41 H	331	47.15	36.05
5	#10360.00	53.5 PK	68.3	-14.8	1.13 H	17	7.58	45.92
ANTENNA POLARITY & TEST DISTANCE: VERTICAL AT 3 M								
NO.	FREQ. (MHz)	EMISSION LEVEL (dBuV/m)	LIMIT (dBuV/m)	MARGIN (dB)	ANTENNA HEIGHT (m)	TABLE ANGLE (Degree)	RAW VALUE (dBuV)	CORRECTION FACTOR (dB/m)
1	5143.50	56.0 PK	74.0	-18.0	1.00 V	3	20.05	35.99
2	5143.50	44.6 AV	54.0	-9.4	1.00 V	3	8.57	35.99
3	*5180.00	103.5 PK			1.00 V	0	67.45	36.05
4	*5180.00	93.9 AV			1.00 V	0	57.85	36.05
5	#10360.00	53.7 PK	68.3	-14.6	1.05 V	14	7.78	45.92

- REMARKS:**
1. Emission level (dBuV/m) = Raw Value (dBuV) + Correction Factor (dB/m).
 2. Correction Factor (dB/m) = Antenna Factor (dB/m) + Cable Factor (dB).
 3. The other emission levels were very low against the limit.
 4. Margin value = Emission level – Limit value.
 5. “ * “: Fundamental frequency.
 6. “#”:The radiated frequency is out the restricted band.



A D T

EUT TEST CONDITION		MEASUREMENT DETAIL	
CHANNEL	Channel 40	FREQUENCY RANGE	1 ~ 40GHz
INPUT POWER	120Vac, 60 Hz	DETECTOR FUNCTION	Peak (PK) Average (AV)
ENVIRONMENTAL CONDITIONS	20deg. C, 72%RH 1013 hPa	TESTED BY	Phoenix Huang

ANTENNA POLARITY & TEST DISTANCE: HORIZONTAL AT 3 M								
NO.	FREQ. (MHz)	EMISSION LEVEL (dBuV/m)	LIMIT (dBuV/m)	MARGIN (dB)	ANTENNA HEIGHT (m)	TABLE ANGLE (Degree)	RAW VALUE (dBuV)	CORRECTION FACTOR (dB/m)
1	*5200.00	92.7 PK			1.40 H	338	56.62	36.08
2	*5200.00	83.7 AV			1.40 H	338	47.62	36.08
3	#10400.00	53.7 PK	68.3	-14.6	1.39 H	77	7.71	45.99
ANTENNA POLARITY & TEST DISTANCE: VERTICAL AT 3 M								
NO.	FREQ. (MHz)	EMISSION LEVEL (dBuV/m)	LIMIT (dBuV/m)	MARGIN (dB)	ANTENNA HEIGHT (m)	TABLE ANGLE (Degree)	RAW VALUE (dBuV)	CORRECTION FACTOR (dB/m)
1	*5200.00	104.9 PK			1.00 V	358	68.82	36.08
2	*5200.00	95.8 AV			1.00 V	358	59.72	36.08
3	#10400.00	54.0 PK	68.3	-14.3	1.29 V	20	8.01	45.99

- REMARKS:**
1. Emission level (dBuV/m) = Raw Value (dBuV) + Correction Factor (dB/m).
 2. Correction Factor (dB/m) = Antenna Factor (dB/m) + Cable Factor (dB).
 3. The other emission levels were very low against the limit.
 4. Margin value = Emission level – Limit value.
 5. “ * “: Fundamental frequency.
 6. "#":The radiated frequency is out the restricted band.



A D T

EUT TEST CONDITION		MEASUREMENT DETAIL	
CHANNEL	Channel 48	FREQUENCY RANGE	1 ~ 40GHz
INPUT POWER	120Vac, 60 Hz	DETECTOR FUNCTION	Peak (PK) Average (AV)
ENVIRONMENTAL CONDITIONS	20deg. C, 72%RH 1013 hPa	TESTED BY	Phoenix Huang

ANTENNA POLARITY & TEST DISTANCE: HORIZONTAL AT 3 M								
NO.	FREQ. (MHz)	EMISSION LEVEL (dBuV/m)	LIMIT (dBuV/m)	MARGIN (dB)	ANTENNA HEIGHT (m)	TABLE ANGLE (Degree)	RAW VALUE (dBuV)	CORRECTION FACTOR (dB/m)
1	*5240.00	92.4 PK			1.40 H	334	56.26	36.14
2	*5240.00	83.5 AV			1.40 H	334	47.36	36.14
3	5350.00	58.9 PK	74.0	-15.2	1.40 H	335	22.53	36.32
4	5350.00	47.9 AV	54.0	-6.1	1.40 H	335	11.55	36.32
5	#10480.00	53.8 PK	68.3	-14.5	1.20 H	39	7.48	46.32
ANTENNA POLARITY & TEST DISTANCE: VERTICAL AT 3 M								
NO.	FREQ. (MHz)	EMISSION LEVEL (dBuV/m)	LIMIT (dBuV/m)	MARGIN (dB)	ANTENNA HEIGHT (m)	TABLE ANGLE (Degree)	RAW VALUE (dBuV)	CORRECTION FACTOR (dB/m)
1	*5240.00	104.8 PK			1.00 V	356	68.66	36.14
2	*5240.00	95.3 AV			1.00 V	356	59.16	36.14
3	5350.00	59.2 PK	74.0	-14.9	1.02 V	355	22.83	36.32
4	5350.00	47.2 AV	54.0	-6.9	1.02 V	355	10.83	36.32
5	#10480.00	54.1 PK	68.3	-14.2	1.13 V	19	7.98	46.12

- REMARKS:**
1. Emission level (dBuV/m) = Raw Value (dBuV) + Correction Factor (dB/m).
 2. Correction Factor (dB/m) = Antenna Factor (dB/m) + Cable Factor (dB).
 3. The other emission levels were very low against the limit.
 4. Margin value = Emission level – Limit value.
 5. “ * “: Fundamental frequency.
 6. “ # “: The radiated frequency is out the restricted band.



A D T

RESTRICTED BANDEDGE (802.11a MODE, CH36, HORIZONTAL)

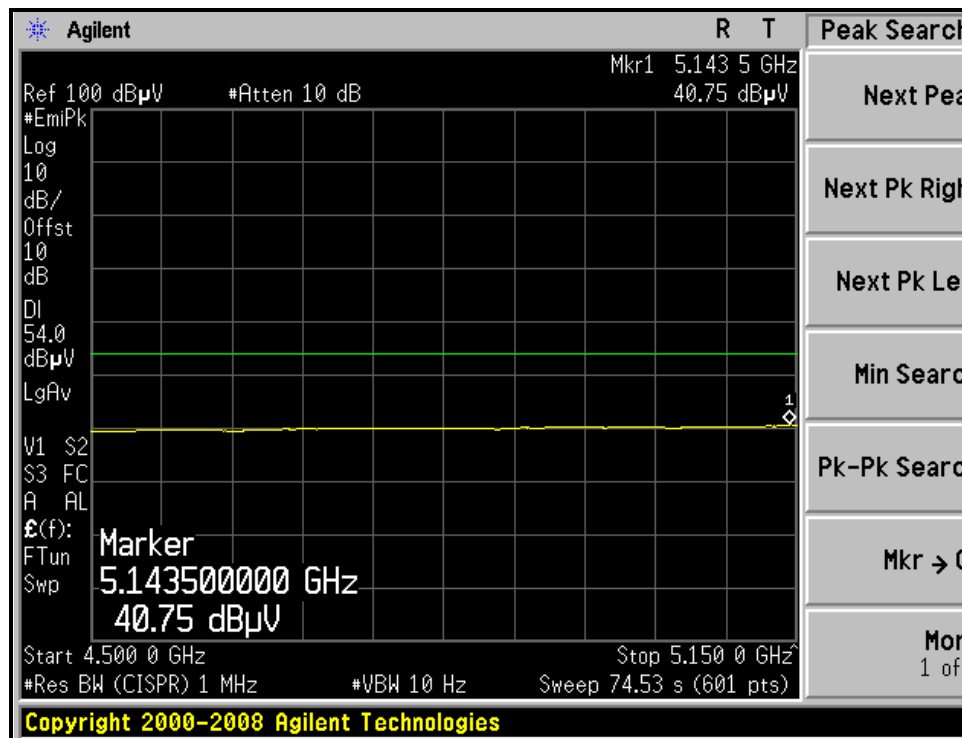
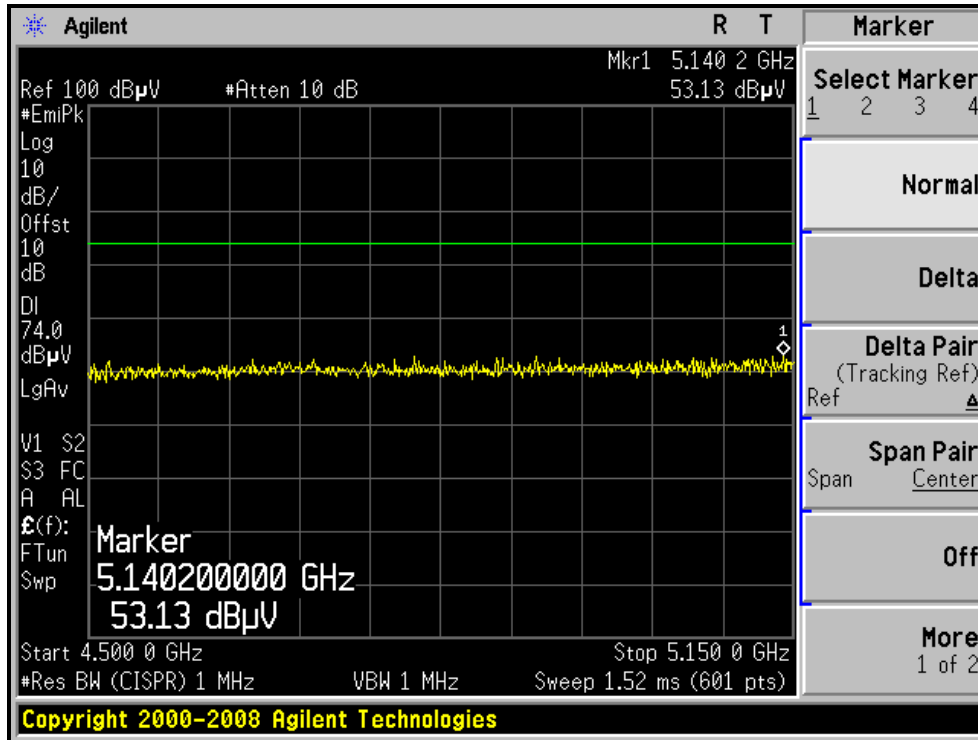



A D T

RESTRICTED BANDEDGE (802.11a MODE, CH36, VERTICAL)

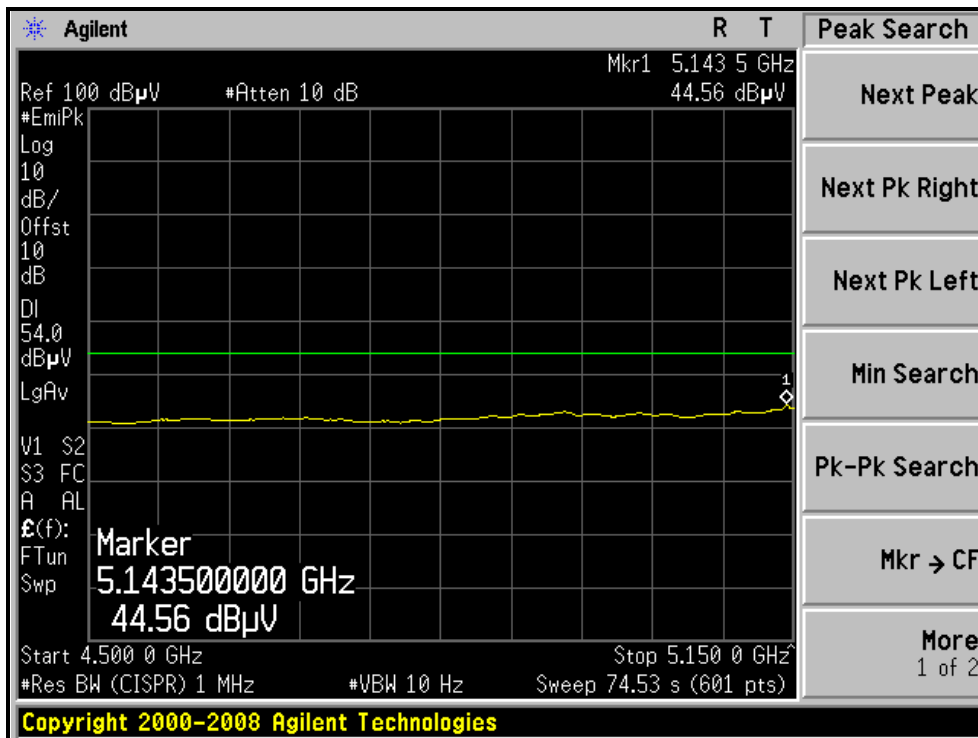
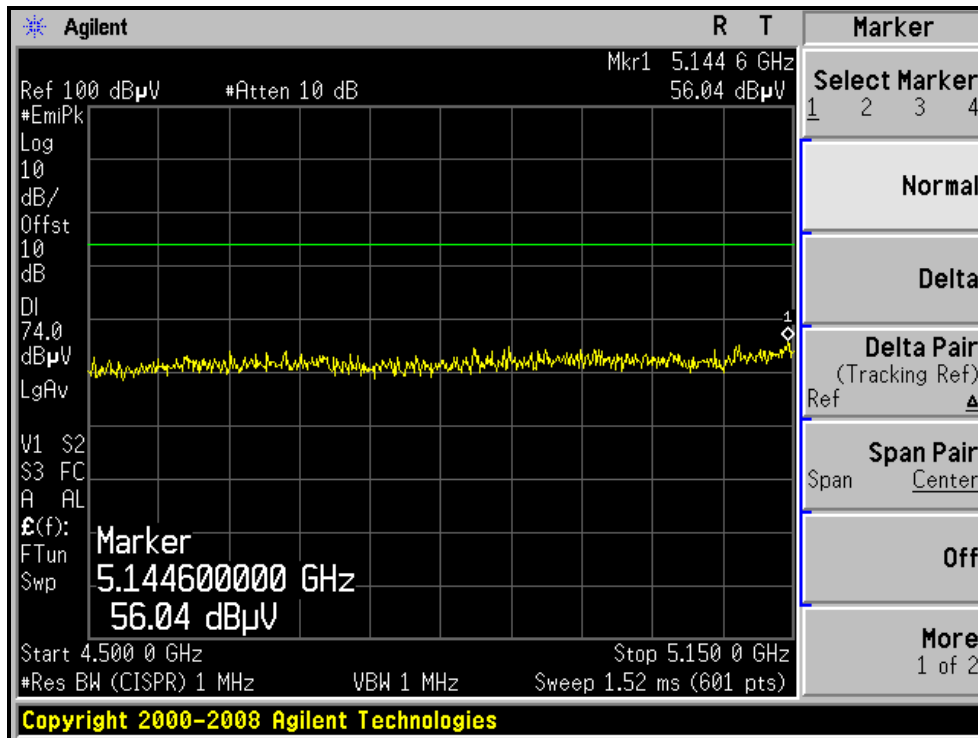



A D T

RESTRICTED BANDEDGE (802.11a MODE, CH48, HORIZONTAL)

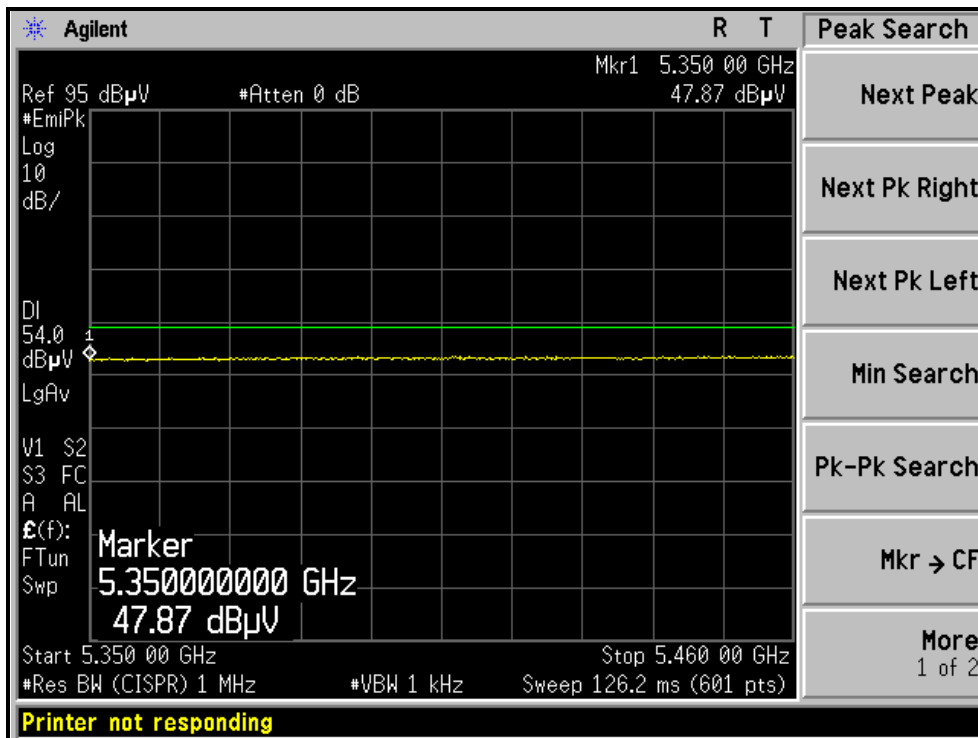
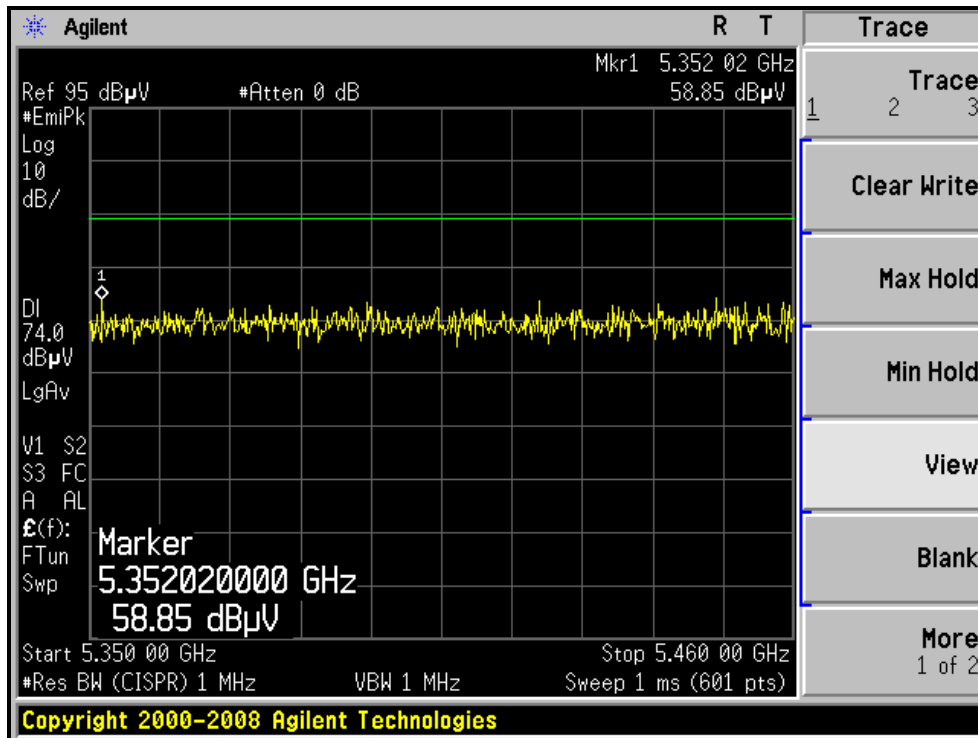



A D T

RESTRICTED BANDEDGE (802.11a MODE, CH48, VERTICAL)

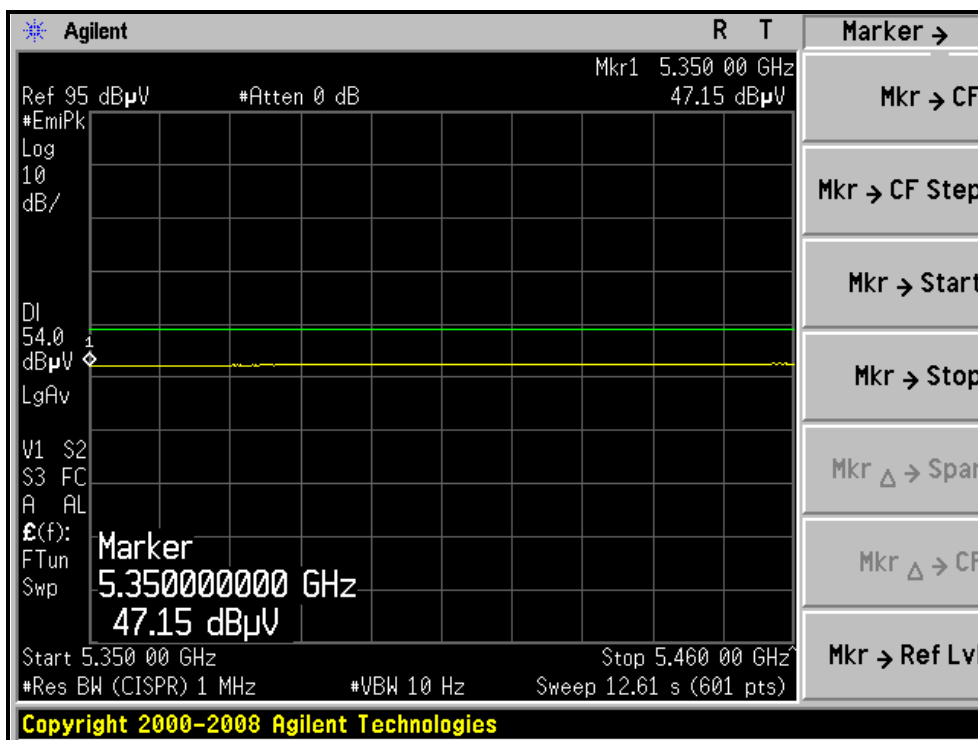
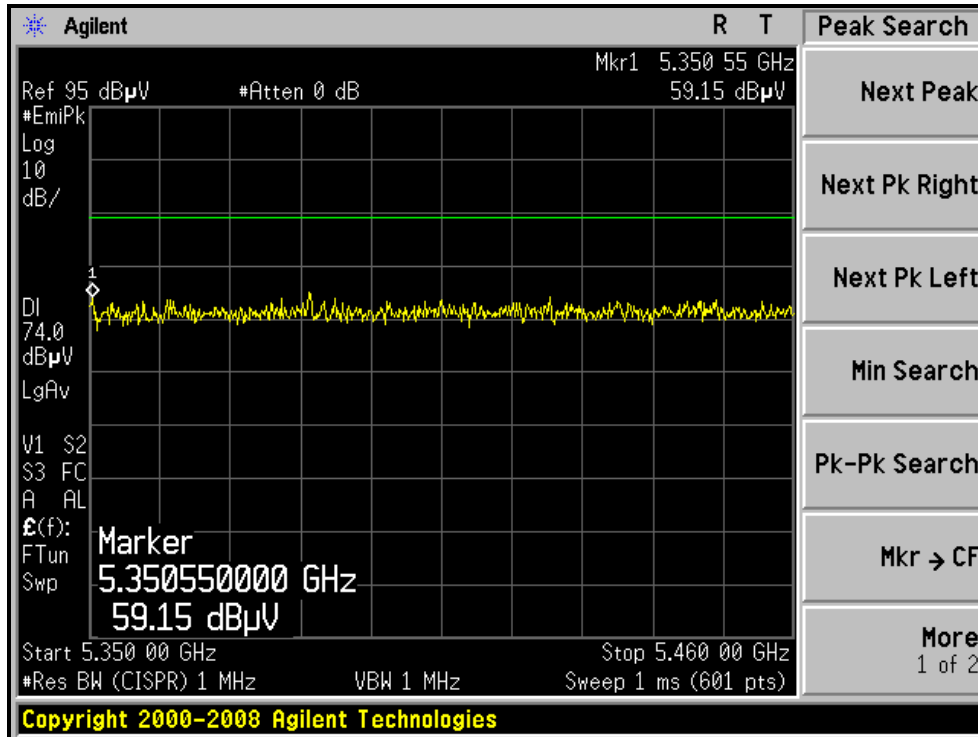

4.2 PEAK TRANSMIT POWER MEASUREMENT

4.2.1 LIMITS OF PEAK TRANSMIT POWER MEASUREMENT

Frequency Band	Limit
5.15 – 5.25GHz	The lesser of 50mW (17dBm) or 4dBm + 10logB
5.25 – 5.35GHz	The lesser of 250mW (24dBm) or 11dBm + 10logB
5.47 – 5.725GHz	The lesser of 250mW (24dBm) or 11dBm + 10logB
5.725 – 5.825GHz	The lesser of 1W (30dBm) or 17dBm + 10logB

NOTE: Where B is the 26dB emission bandwidth in MHz.

4.2.2 TEST INSTRUMENTS

DESCRIPTION & MANUFACTURER	MODEL NO.	SERIAL NO.	CALIBRATED DATE	CALIBRATED UNTIL
Anritsu Power Meter	ML2495A	0824006	April 25, 2009	April 24, 2010
Pulse Power Sensor	MA2411B	0738172	April 25, 2009	April 24, 2010

NOTE:

The calibration interval of the above test instruments is 12 months and the calibrations are traceable to NML/ROC and NIST/USA.

4.2.3 TEST PROCEDURE

1. The transmitter output was connected to the spectrum analyzer.
2. Set span to encompass the entire emission bandwidth of the signal.
3. Set RBW to 1MHz, VBW to 300kHz.
4. Using the spectrum analyzer's channel power measurement function to measure the output power.

NOTE:

The test is performed in accordance with FCC Public Notice: APPENDIX A Guidelines for Assessing Unlicensed National Information Infrastructure (U-NII) Devices – Part 15, Subpart E, August 2002.

The transmitter output operates continuously therefore Method # 1 is used.

4.2.4 DEVIATION FROM TEST STANDARD

No deviation

4.2.5 TEST SETUP

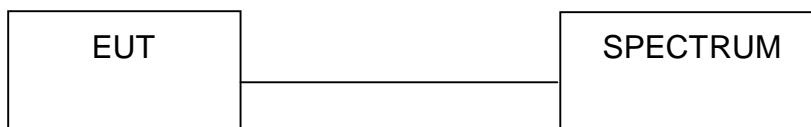

4.2.6 EUT OPERATING CONDITIONS

The software provided by client to enable the EUT under transmission condition continuously at specific channel frequencies individually.



A D T

4.2.7 TEST RESULTS

802.11a OFDM MODULATION:

CHANNEL	CHANNEL FREQUENCY (MHz)	PEAK POWER OUTPUT (dBm)	PEAK POWER OUTPUT (mW)	PEAK POWER LIMIT (dBm)	PASS/FAIL
36	5180	8.6	7.2	10	PASS
40	5200	8.9	7.8	10	PASS
48	5240	8.9	7.8	10	PASS

Peak Power Output:
CH40

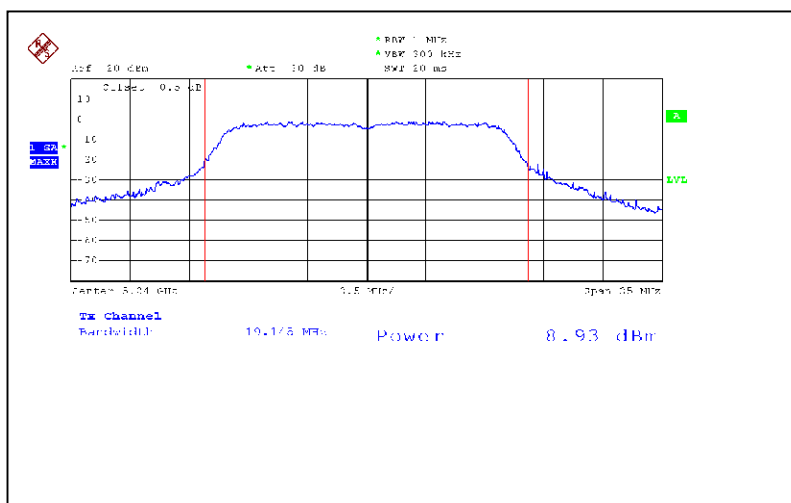



5. INFORMATION ON THE TESTING LABORATORIES

We, Bureau Veritas Consumer Products Services (H.K.) Ltd., Taoyuan Branch, were founded in 1988 to provide our best service in EMC, Radio, Telecom and Safety consultation. Our laboratories are accredited and approved according to ISO/IEC 17025:

Copies of accreditation certificates of our laboratories obtained from approval agencies can be downloaded from our web site: www.adt.com.tw/index.5/phtml. If you have any comments, please feel free to contact us at the following:

Linko EMC/RF Lab:
Tel: 886-2-26052180
Fax: 886-2-26052943

Hsin Chu EMC/RF Lab:
Tel: 886-3-5935343
Fax: 886-3-5935342

Hwa Ya EMC/RF/Safety Telecom Lab:
Tel: 886-3-3183232
Fax: 886-3-3185050

Web Site: www.adt.com.tw

The address and road map of all our labs can be found in our web site also



A D T

6.APPENDIX-A- Modifications recorders for engineering changes to the eut BY THE LAB

No any modifications are made to the EUT by the lab during the test.

---END---