



DFS TEST REPORT

REPORT NO.: RF960308H04

MODEL NO.: 21-92955

RECEIVED: March 09, 2007

TESTED: March 20 to 29, 2007

ISSUED: March 29, 2007

APPLICANT: Symbol Technologies Inc.

ADDRESS: One Symbol Plaza, Holtsville, NY 11742-1300 U.S.A.

ISSUED BY: Advance Data Technology Corporation

TEST LOCATION: No. 81-1, Lu Liao Keng, 9 Ling, Wu Lung Tsuen, Chiung Lin Hsiang, Hsin Chu Hsien, Taiwan, R.O.C.

This test report consists of 19 pages in total. It may be duplicated completely for legal use with the approval of the applicant. It should not be reproduced except in full, without the written approval of our laboratory. The client should not use it to claim product endorsement by CNLA, A2LA or any government agencies. The test results in the report only apply to the tested sample.





Table of Contents

| | | |
|--------|---|-----|
| 1. | CERTIFICATION..... | 3 |
| 2. | SUMMARY OF TEST RESULTS..... | 4 |
| 2.1 | DYNAMIC FREQUENCY SELECTION | 4 |
| 2.1.1 | OPERATING FREQUENCY OF U-NII DEVICE..... | 5 |
| 2.1.2 | TEST LIMITS AND RADAR SIGNAL PARAMETERS | 5 |
| 2.1.3 | TEST INSTRUMENTS | 8 |
| 2.1.4 | DESCRIPTION OF SUPPORT UNITS | 8 |
| 2.1.5 | SOFTWARE AND FIRMWARE..... | 8 |
| 2.1.6 | DESCRIPTION OF AVAILABLE ANTENNAS..... | 9 |
| 2.1.7 | MAXIMUM AND MINIMUM CONDUCTED POWER..... | 9 |
| 2.1.8 | MAXIMUM AND MINIMUM E.I.R.P. POWER..... | 9 |
| 2.1.9 | STATEMENT OF MAUNFACTURER..... | 10 |
| 2.1.10 | TEST PROCEDURE..... | 10 |
| 2.1.11 | DEVIATION FROM TEST STANDARD..... | 12 |
| 2.1.12 | CONDUCTED TEST SETUP CONFIGURATION..... | 12 |
| 2.1.13 | LIST OF MEASUREMENTS | 13 |
| 2.1.14 | TEST RESULTS..... | 14 |
| 2.2 | ANTENNA REQUIREMENT | 17 |
| 2.2.1 | STANDARD APPLICABLE..... | 17 |
| 2.2.2 | ANTENNA CONNECTED CONSTRUCTION..... | 17 |
| 3 | INFORMATION ON THE TESTING LABORATORIES..... | 18 |
| | APPENDIX-A | A-1 |



1. CERTIFICATION

PRODUCT: 802.11a/b/g WLAN SDIO Radio Module
BRAND NAME: Symbol Technologies Inc.
MODEL NO.: 21-92955
TEST SAMPLE: ENGINEERING SAMPLE
TESTED: March 20 to 29, 2007
APPLICANT: Symbol Technologies Inc.
STANDARDS: **FCC Part 15, Subpart E (Section 15.407)**
FCC 06-96

The above equipment (Model: 21-92955) has been tested by **Advance Data Technology Corporation**, and found compliance with the requirement of the above standards. The test record, data evaluation & Equipment Under Test (EUT) configurations represented herein are true and accurate accounts of the measurements of the sample's EMC characteristics under the conditions specified in this report.

PREPARED BY : Carol Liao , **DATE:** March 29, 2007
(Carol Liao)

TECHNICAL ACCEPTANCE : Moris Lin , **DATE:** March 29, 2007
Responsible for RF (Moris Lin)

APPROVED BY : Hank Chung , **DATE:** March 29, 2007
(Hank Chung, Deputy Manager)

2. SUMMARY OF TEST RESULTS

2.1 DYNAMIC FREQUENCY SELECTION

The manufacturer shall state whether the UUT is capable of operating as a Master and/or a Client. If the UUT is capable of operating in more than one operating mode then each operating mode shall be tested separately. See tables 1 and 2 for the applicability of DFS requirements for each of the operational modes.

Table 1: Applicability of DFS requirements prior to use a channel

| Requirement | Operational Mode | | |
|---------------------------------|------------------|--------------------------------|-----------------------------|
| | Master | Client without radar detection | Client with radar detection |
| Non-Occupancy Period | ü | Not required | ü |
| DFS Detection Threshold | ü | Not required | ü |
| Channel Availability Check Time | ü | Not required | Not required |
| Uniform Spreading | ü | Not required | Not required |
| U-NII Detection Bandwidth | ü | Not required | ü |

Table 2: Applicability of DFS requirements during normal operation.

| Requirement | Operational Mode | | |
|-----------------------------------|------------------|--------------------------------|-----------------------------|
| | Master | Client without radar detection | Client with radar detection |
| DFS Detection Threshold | ü | Not required | ü |
| Channel Closing Transmission Time | ü | ü | ü |
| Channel Move Time | ü | ü | ü |
| U-NII Detection Bandwidth | ü | Not required | ü |

2.1.1 OPERATING FREQUENCY OF U-NII DEVICE

Table 3: Operating frequency range of UUT.

| Operational Mode | Operating Frequency Range | |
|--------------------------------|---------------------------|--------------|
| | 5250~5350MHz | 5470~5725MHz |
| Master | ü | ü |
| Client without radar detection | Not Apply | Not Apply |
| Client with radar detection | ü | ü |

2.1.2 TEST LIMITS AND RADAR SIGNAL PARAMETERS

DETECTION THRESHOLD VALUES

Table 4: DFS Detection Thresholds for Master Devices and Client Devices With Radar Detection.

| Maximum Transmit Power | Value (See Notes 1 and 2) |
|------------------------|------------------------------|
| ≥ 200 milliwatt | -64 dBm |
| < 200 milliwatt | -62 dBm |

Note 1: This is the level at the input of the receiver assuming a 0 dBi receive antenna.

Note 2: Throughout these test procedures an additional 1 dB has been added to the amplitude of the test transmission waveforms to account for variations in measurement equipment. This will ensure that the test signal is at or above the detection threshold level to trigger a DFS response.

Table 5: DFS Response Requirement Values

| Parameter | Value |
|-----------------------------------|---|
| Non-occupancy period | Minimum 30 minutes |
| Channel Availability Check Time | 60 seconds |
| Channel Move Time | 10 seconds See Note 1. |
| Channel Closing Transmission Time | 200 milliseconds + an aggregate of 60 milliseconds over remaining 10 second period. See Notes 1 and 2. |
| U-NII Detection Bandwidth | Minimum 80% of the UNII 99% transmission power bandwidth. See Note 3. |

Note 1: The instant that the Channel Move Time and the Channel Closing Transmission Time begins is as follows:

- For the Short Pulse Radar Test Signals this instant is the end of the Burst.
- For the Frequency Hopping radar Test Signal, this instant is the end of the last radar Burst generated.
- For the Long Pulse Radar Test Signal this instant is the end of the 12 second period defining the Radar Waveform.

Note 2: The Channel Closing Transmission Time is comprised of 200 milliseconds starting at the beginning of the Channel Move Time plus any additional intermittent control signals required to facilitate a Channel move (an aggregate of 60 milliseconds) during the remainder of the 10 second period. The aggregate duration of control signals will not count quiet periods in between transmissions.

Note 3: During the U-NII Detection Bandwidth detection test, radar type 1 is used and for each frequency step the minimum percentage of detection is 90 percent. Measurements are performed with no data traffic.

PARAMETERS OF DFS TEST SIGNALS

Step intervals of 0.1 microsecond for Pulse Width, 1 microsecond for PRI, 1 MHz for chirp width and 1 for the number of pulses will be utilized for the random determination of specific test waveforms.

Table 6: Short Pulse Radar Test Waveforms.

| Radar Type | Pulse Width (µsec) | PRI (µsec) | Number of Pulses | Minimum Percentage of Successful Detection | Minimum Number of Trials |
|-----------------------------|--------------------|------------|------------------|--|--------------------------|
| 1 | 1 | 1428 | 18 | 60% | 30 |
| 2 | 1-5 | 150-230 | 23-29 | 60% | 30 |
| 3 | 6-10 | 200-500 | 16-18 | 60% | 30 |
| 4 | 11-20 | 200-500 | 12-16 | 60% | 30 |
| Aggregate (Radar Types 1-4) | | | | 80% | 120 |

Table 7: Long Pulse Radar Test Waveform

| Radar Type | Pulse Width (µsec) | Chirp Width (MHz) | PRI (µsec) | Number of Pulses per Burst | Number of Bursts | Minimum Percentage of Successful Detection | Minimum Number of Trials |
|------------|--------------------|-------------------|------------|----------------------------|------------------|--|--------------------------|
| 5 | 50-100 | 5-20 | 1000-2000 | 1-3 | 8-20 | 80% | 30 |

Table 8: Frequency Hopping Radar Test Waveform

| Radar Type | Pulse Width (µsec) | PRI (µsec) | Pulses per Hop | Hopping Rate (kHz) | Hopping Sequence Length (msec) | Minimum Percentage of Successful Detection | Minimum Number of Trials |
|------------|--------------------|------------|----------------|--------------------|--------------------------------|--|--------------------------|
| 6 | 1 | 333 | 9 | 0.333 | 300 | 70% | 30 |

2.1.3 TEST INSTRUMENTS

Table 9: Test instruments list.

| DESCRIPTION & MANUFACTURER | MODEL NO. | BRAND | CALIBRATED UNTIL |
|----------------------------|-----------|-----------|------------------|
| R&S Spectrum analyzer | FSP40 | R&S | Aug. 15, 2007 |
| Signal generator | 8645A | Agilent | May. 26, 2008 |
| Oscilloscope | TDS 5104 | Tektronix | Apr. 05. 2007 |

2.1.4 DESCRIPTION OF SUPPORT UNITS

Table 10: Support Unit information.

| No. | Product | Brand | Model No. | ID | Spec. |
|-----|--------------------------|-------|-------------------|-----------|--|
| 1 | 802.11a/b/g Access Point | Cisco | AIR-AP1242AG-A-K9 | LDK102056 | The maximum EIRP is 21.5 dBm, Antenna Gain is 3dBi |

2.1.5 SOFTWARE AND FIRMWARE

Table 11: The software/firmware version for U-NII device.

| No. | Product | Model No. | Software/Firmware Version |
|-----|------------------------------------|-------------------|---------------------------|
| 1 | 802.11a/b/g WLAN SDIO Radio Module | 21-92955 | Version 3.0.0.521 |
| 2 | 802.11a/b/g Access Point | AIR-AP1242AG-A-K9 | C1240-K9W7-TAR.123-11.JA |

2.1.6 DESCRIPTION OF AVAILABLE ANTENNAS

Table 12: Antenna list.

| Ant NO. | Antenna | Type | Operation Frequency Range | Max. Gain(dBi) |
|---------|----------------------|--------|---------------------------|----------------|
| 1 | DIPOLE,C802-510001-A | Dipole | 5.15 – 5.85 GHz | 2.8 |

2.1.7 MAXIMUM AND MINIMUM CONDUCTED POWER

Table 13: The measured conducted output power.

| Ant NO. | Frequency Band(MHZ) | MAX. Power | | MIN. Power | |
|---------|---------------------|-------------------|------------------|-------------------|------------------|
| | | Output Power(dBm) | Output Power(mW) | Output Power(dBm) | Output Power(mW) |
| 1 | 5250~5350MHz | 15.42 | 34.8337315 | 5.91 | 3.899419867 |
| 1 | 5470~5725MHz | 14.04 | 25.3512863 | 2.2 | 1.659586907 |

2.1.8 MAXIMUM AND MINIMUM E.I.R.P. POWER

Table 14: The E.I.R.P output power list.

| Ant NO. | Frequency Band(MHZ) | MAX. Power | | MIN. Power | |
|---------|---------------------|-------------------|------------------|-------------------|------------------|
| | | Output Power(dBm) | Output Power(mW) | Output Power(dBm) | Output Power(mW) |
| 1 | 5250~5350MHz | 18.22 | 66.37430704 | 8.71 | 7.430191379 |
| 1 | 5470~5725MHz | 16.84 | 48.3058802 | 5 | 3.16227766 |

2.1.9 STATEMENT OF MAUNFACTURER

Manufacturer statement confirming that information regarding the parameters of the detected Radar Waveforms is not available to the end user.

2.1.10 TEST PROCEDURE

ADT DFS Measurement System:

A complete ADT DFS Measurement System consists of two subsystems: (1) the Radar Signal Generating Subsystem and (2) the Traffic Monitoring Subsystem. The control PC is necessary for generating the Radar waveforms in Table 6, 7 and 8. The traffic monitoring subsystem is specified to the type of unit under test (UUT).

Conducted setup configuration of ADT DFS Measurement System

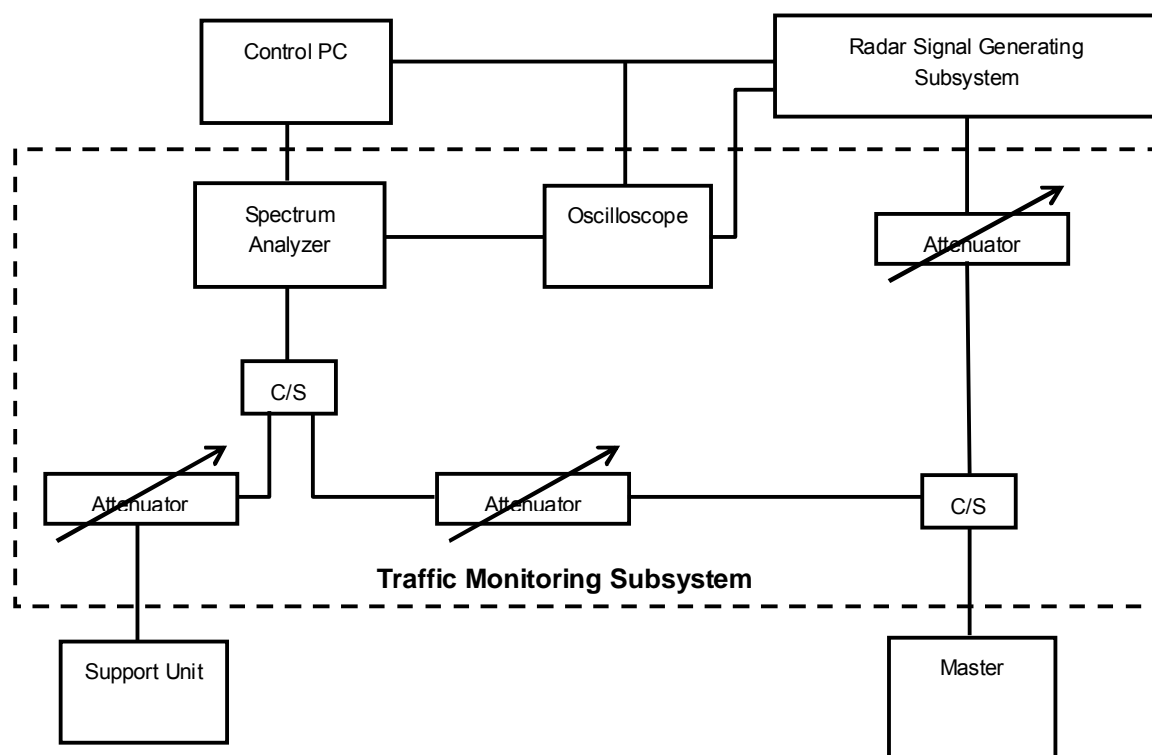

The test transmission will always be from the Master Device to the Client Device. While the Client device is set up to associate with the Master device and play the WAV file from Master device, the designated WAV test file and instructions are located at: <http://ntiacsd.ntia.doc.gov/dfs/>. The test with WAV file, because MPEG2 file cannot be played with the EUT.

Calibration of DFS Detection Threshold Level:

The measured channel is 5320MHz. The radar signal was the same as transmitted channels, and injected into the antenna port of AP (master), measured the channel closing transmission time and channel move time. The Required detection threshold is -58dBm ($= -62 + 1 + 3$)dBm. The calibrated conducted detection threshold level is set to -59dBm . The tested level is lower than required level hence it provides margin to the limit.

Conducted setup configuration of Calibration of DFS Detection Threshold Level

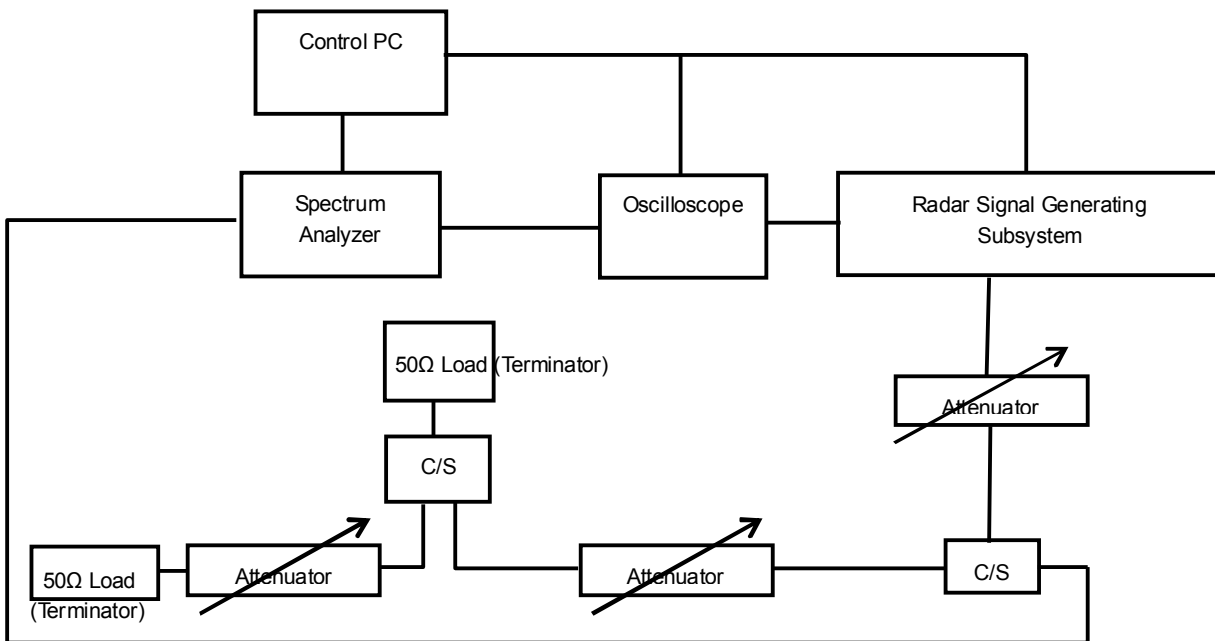

2.1.11 DEVIATION FROM TEST STANDARD

No deviation.

2.1.12 CONDUCTED TEST SETUP CONFIGURATION

Client without radar detection mode (Radar injected into Master)

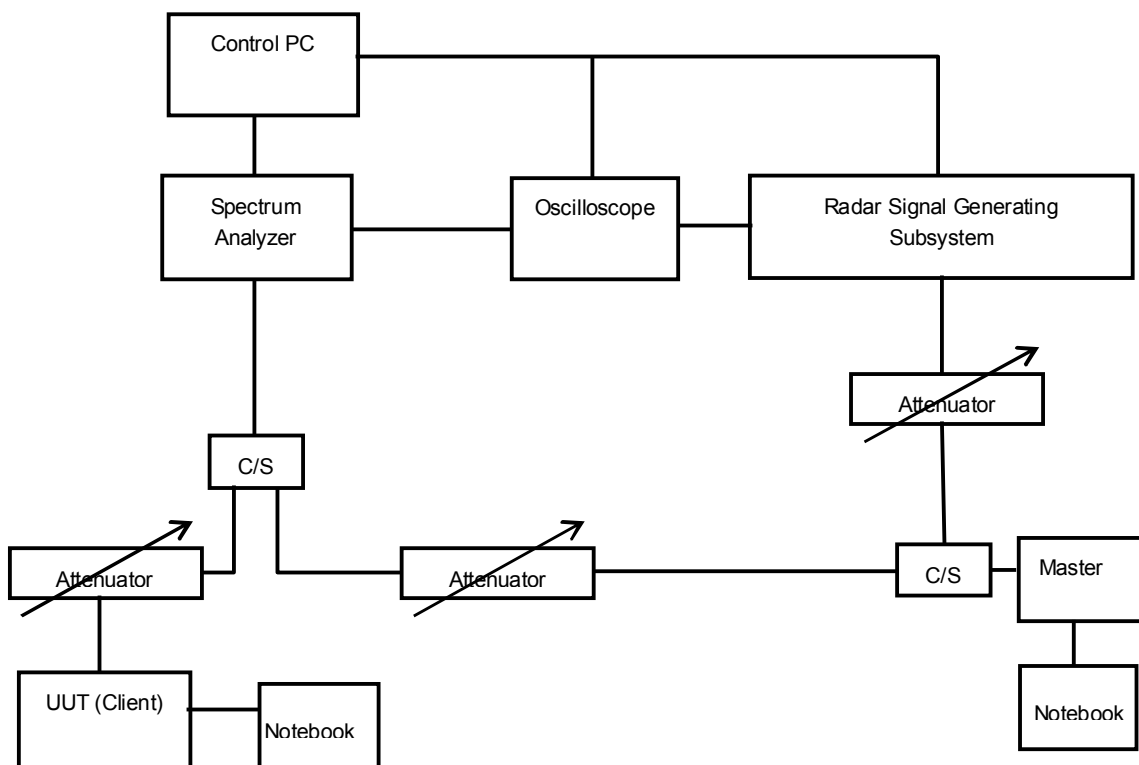

The UUT is a U-NII Device operating in Client mode with radar detection. The radar test signals are injected into the Master Device.

2.1.13 LIST OF MEASUREMENTS

The UUT is capable of operating as a Client without radar detection.

| Clause | Test Parameter | Remarks | Pass/Fail |
|--------|-----------------------------------|----------------|-----------|
| 15.407 | DFS Detection Threshold | Not Applicable | NA |
| 15.407 | Channel Availability Check Time | Not Applicable | NA |
| 15.407 | Channel Move Time | Applicable | Pass |
| 15.407 | Channel Closing Transmission Time | Applicable | Pass |
| 15.407 | Non- Occupancy Period | Not Applicable | NA |
| 15.407 | Uniform Spreading | Not Applicable | NA |
| 15.407 | U-NII Detection Bandwidth | Not Applicable | NA |

2.1.14 TEST RESULTS

The UUT is a U-NII Device operating in Client without Radar Detection mode. The radar test signals are injected into the Master Device.

1. DFS DETECTION THRESHOLD

For a detection threshold level of -62dBm and the Master antenna gain is 3dBi . The Required detection threshold is -58dBm ($= -62 + 1 + 3$) dBm . The conducted radar burst level is set to -59dBm . The tested level is lower than required level hence it provides margin to the limit.

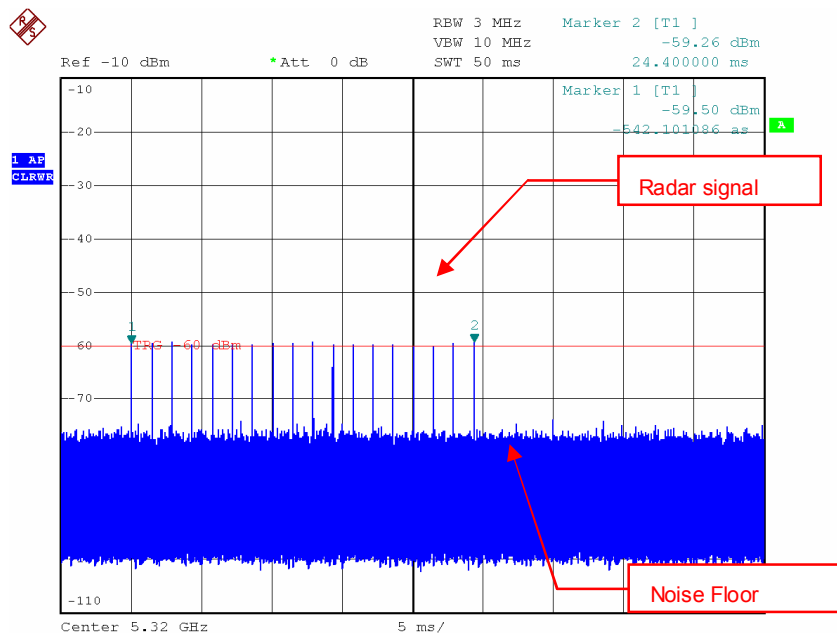

Date: 21.MAR.2007 02:15:56

Radar Signal 1

2. Channel Closing Transmission and Channel Move Time

Radar signal 1

Channel Closing Transmission Time & Channel Move Time @ CH064 - 5320MHz

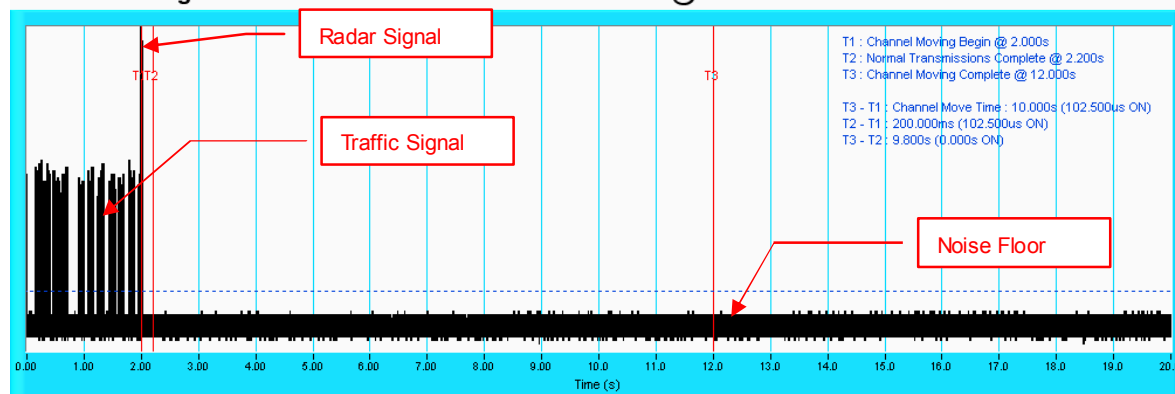

NOTE: T1 denotes the start of Channel Move Time upon the end of the last Radar burst. T2 denotes the data transmission time of 200ms from T1. T3 denotes the 10 second from T1 to observe the aggregate duration of transmissions.

Channel Closing Transmission Time & Channel Move Time @ CH064 - 5320MHz

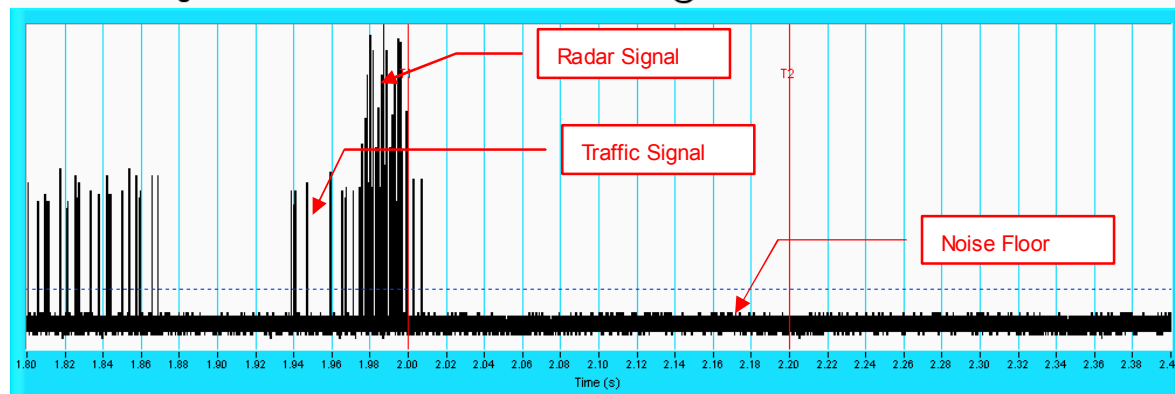

NOTE: An expanded plot for the device vacates the channel in the required 200ms.



Type 1 Radar Statistical Performances

| Trial # | Pulses per Burst | Pulse Width (s) | PRI (s) | Detection |
|---------|------------------|-----------------|---------|-----------|
| 1 | 18 | 1.0u | 1.428m | Yes |
| 2 | 18 | 1.0u | 1.428m | Yes |
| 3 | 18 | 1.0u | 1.428m | Yes |
| 4 | 18 | 1.0u | 1.428m | Yes |
| 5 | 18 | 1.0u | 1.428m | Yes |
| 6 | 18 | 1.0u | 1.428m | Yes |
| 7 | 18 | 1.0u | 1.428m | Yes |
| 8 | 18 | 1.0u | 1.428m | Yes |
| 9 | 18 | 1.0u | 1.428m | Yes |
| 10 | 18 | 1.0u | 1.428m | Yes |
| 11 | 18 | 1.0u | 1.428m | Yes |
| 12 | 18 | 1.0u | 1.428m | Yes |
| 13 | 18 | 1.0u | 1.428m | Yes |
| 14 | 18 | 1.0u | 1.428m | Yes |
| 15 | 18 | 1.0u | 1.428m | Yes |
| 16 | 18 | 1.0u | 1.428m | Yes |
| 17 | 18 | 1.0u | 1.428m | Yes |
| 18 | 18 | 1.0u | 1.428m | Yes |
| 19 | 18 | 1.0u | 1.428m | Yes |
| 20 | 18 | 1.0u | 1.428m | Yes |
| 21 | 18 | 1.0u | 1.428m | Yes |
| 22 | 18 | 1.0u | 1.428m | Yes |
| 23 | 18 | 1.0u | 1.428m | Yes |
| 24 | 18 | 1.0u | 1.428m | Yes |
| 25 | 18 | 1.0u | 1.428m | Yes |
| 26 | 18 | 1.0u | 1.428m | Yes |
| 27 | 18 | 1.0u | 1.428m | Yes |
| 28 | 18 | 1.0u | 1.428m | Yes |
| 29 | 18 | 1.0u | 1.428m | Yes |
| 30 | 18 | 1.0u | 1.428m | Yes |

Detection Rate: 100 %



2.2 ANTENNA REQUIREMENT

2.2.1 STANDARD APPLICABLE

For intentional device, according to FCC 47 CFR Section 15.203, an intentional radiator shall be designed to ensure that no antenna other than that furnished by the responsible party shall be used with the device.

And according to FCC 47 CFR Section 15.407(a), if transmitting antennas of directional gain greater than 6dBi are used, the power shall be reduced by the amount in dB that the directional gain of the antenna exceeds 6dBi.

2.2.2 ANTENNA CONNECTED CONSTRUCTION

The antenna used in this product is dipole antenna with RP-SMA MALE connector. The maximum Gain of the antenna is 2.8dBi.



3 INFORMATION ON THE TESTING LABORATORIES

We, ADT Corp., were founded in 1988 to provide our best service in EMC, Radio, Telecom and Safety consultation. Our laboratories are accredited and approved by the following approval agencies according to ISO/IEC 17025.

| | |
|--------------------|-----------------------|
| USA | FCC, UL, A2LA |
| Germany | TUV Rheinland |
| Japan | VCCI |
| Norway | NEMKO |
| Canada | INDUSTRY CANADA , CSA |
| R.O.C. | CNLA, BSMI, NCC |
| Netherlands | Telefication |
| Singapore | PSB , GOST-ASIA(MOU) |
| Russia | CERTIS(MOU) |

Copies of accreditation certificates of our laboratories obtained from approval agencies can be downloaded from our web site:
www.adt.com.tw/index.5/phtml. If you have any comments, please feel free to contact us at the following:

Linko EMC/RF Lab:

Tel: 886-2-26052180

Fax: 886-2-26051924

Hsin Chu EMC/RF Lab:

Tel: 886-3-5935343

Fax: 886-3-5935342

Hwa Ya EMC/RF/Safety Telecom Lab:

Tel: 886-3-3183232

Fax: 886-3-3185050

Web Site: www.adt.com.tw

The address and road map of all our labs can be found in our web site also.



APPENDIX-A

MODIFICATIONS RECORDERS FOR ENGINEERING CHANGES TO THE EUT BY THE LAB

No any modifications are made to the EUT by the lab during the test.