



FCC TEST REPORT (15.247)

REPORT NO.: RF960308H04

MODEL NO.: 21-92955

RECEIVED: March 09, 2007

TESTED: March 20 to 29, 2007

ISSUED: March 29, 2007

APPLICANT: Symbol Technologies Inc.

ADDRESS: One Symbol Plaza, Holtsville, NY 11742-1300 U.S.A.

ISSUED BY: Advance Data Technology Corporation

TEST LOCATION: No. 81-1, Lu Liao Keng, 9 Ling, Wu Lung Tsuen, Chiung Lin Hsiang, Hsin Chu Hsien, Taiwan, R.O.C.

This test report consists of 101 pages in total. It may be duplicated completely for legal use with the approval of the applicant. It should not be reproduced except in full, without the written approval of our laboratory. The client should not use it to claim product endorsement by CNLA, A2LA or any government agencies. The test results in the report only apply to the tested sample.



No. 2177-01

Table of Contents

1.	CERTIFICATION	6
2.	SUMMARY OF TEST RESULTS	7
2.1	MEASUREMENT UNCERTAINTY	9
3.	GENERAL INFORMATION	10
3.1	GENERAL DESCRIPTION OF EUT	10
3.2	DESCRIPTION OF TEST MODES	12
3.2.1	TEST MODE APPLICABILITY AND TESTED CHANNEL DETAIL:	13
3.3	GENERAL DESCRIPTION OF APPLIED STANDARDS	15
3.4	DESCRIPTION OF SUPPORT UNITS	16
3.5	CONFIGURATION OF SYSTEM UNDER TEST	16
4.	TEST TYPES AND RESULTS (802.11b & g, 2400 ~ 2483.5MHz Band).....	17
4.1	CONDUCTED EMISSION MEASUREMENT	17
4.1.1	LIMITS OF CONDUCTED EMISSION MEASUREMENT.....	17
4.1.2	TEST INSTRUMENTS	17
4.1.3	TEST PROCEDURES.....	18
4.1.4	DEVIATION FROM TEST STANDARD	18
4.1.5	TEST SETUP	19
4.1.6	EUT OPERATING CONDITIONS	19
4.1.7	TEST RESULTS	20
4.2	RADIATED EMISSION MEASUREMENT	22
4.2.1	LIMITS OF RADIATED EMISSION MEASUREMENT.....	22
4.2.2	TEST INSTRUMENTS	23
4.2.3	TEST PROCEDURES.....	24
4.2.4	DEVIATION FROM TEST STANDARD	24
4.2.5	TEST SETUP	25
4.2.6	EUT OPERATING CONDITIONS	25
4.2.7	TEST RESULTS	26
4.3	6dB BANDWIDTH MEASUREMENT	35
4.3.1	LIMITS OF 6dB BANDWIDTH MEASUREMENT.....	35
4.3.2	TEST INSTRUMENTS	35
4.3.3	TEST PROCEDURE	36



4.3.4	DEVIATION FROM TEST STANDARD	36
4.3.5	TEST SETUP	36
4.3.6	EUT OPERATING CONDITIONS	36
4.3.7	TEST RESULTS	37
4.4	MAXIMUM PEAK OUTPUT POWER	43
4.4.1	LIMITS OF MAXIMUM PEAK OUTPUT POWER MEASUREMENT	43
4.4.2	INSTRUMENTS	43
4.4.3	TEST PROCEDURES	44
4.4.4	DEVIATION FROM TEST STANDARD	44
4.4.5	TEST SETUP	44
4.4.6	EUT OPERATING CONDITIONS	44
4.4.7	TEST RESULTS	45
4.5	POWER SPECTRAL DENSITY MEASUREMENT	47
4.5.1	LIMITS OF POWER SPECTRAL DENSITY MEASUREMENT	47
4.5.2	TEST INSTRUMENTS	47
4.5.3	TEST PROCEDURE	48
4.5.4	DEVIATION FROM TEST STANDARD	48
4.5.5	TEST SETUP	48
4.5.6	EUT OPERATING CONDITION	48
4.5.7	TEST RESULTS	49
4.6	BAND EDGES MEASUREMENT	55
4.6.1	LIMITS OF BAND EDGES MEASUREMENT	55
4.6.2	TEST INSTRUMENTS	55
4.6.3	TEST PROCEDURE	55
4.6.4	EUT OPERATING CONDITION	55
4.6.5	TEST RESULTS	56
4.7	ANTENNA REQUIREMENT	67
4.7.1	STANDARD APPLICABLE	67
4.7.2	ANTENNA CONNECTED CONSTRUCTION	67
5.	TEST TYPES AND RESULTS (802.11a, 5725~5850MHz Band)	68
5.1	CONDUCTED EMISSION MEASUREMENT	68
5.1.1	LIMITS OF CONDUCTED EMISSION MEASUREMENT	68
5.1.2	TEST INSTRUMENTS	68
5.1.3	TEST PROCEDURES	69



5.1.4	DEVIATION FROM TEST STANDARD	69
5.1.5	TEST SETUP	70
5.1.6	EUT OPERATING CONDITIONS	70
5.1.7	TEST RESULTS	71
5.2	RADIATED EMISSION MEASUREMENT	73
5.2.1	LIMITS OF RADIATED EMISSION MEASUREMENT	73
5.2.2	TEST INSTRUMENTS	74
5.2.3	TEST PROCEDURES	75
5.2.4	DEVIATION FROM TEST STANDARD	75
5.2.5	TEST SETUP	76
5.2.6	EUT OPERATING CONDITIONS	76
5.2.7	TEST RESULTS	77
5.3	6dB BANDWIDTH MEASUREMENT	81
5.3.1	LIMITS OF 6dB BANDWIDTH MEASUREMENT	81
5.3.2	TEST INSTRUMENTS	81
5.3.3	TEST PROCEDURE	82
5.3.4	DEVIATION FROM TEST STANDARD	82
5.3.5	TEST SETUP	82
5.3.6	EUT OPERATING CONDITIONS	82
5.3.7	TEST RESULTS	83
5.4	MAXIMUM PEAK OUTPUT POWER	86
5.4.1	LIMITS OF MAXIMUM PEAK OUTPUT POWER MEASUREMENT	86
5.4.2	INSTRUMENTS	86
5.4.3	TEST PROCEDURES	87
5.4.4	DEVIATION FROM TEST STANDARD	87
5.4.5	TEST SETUP	87
5.4.6	EUT OPERATING CONDITIONS	87
5.4.7	TEST RESULTS	88
5.5	POWER SPECTRAL DENSITY MEASUREMENT	89
5.5.1	LIMITS OF POWER SPECTRAL DENSITY MEASUREMENT	89
5.5.2	TEST INSTRUMENTS	89
5.5.3	TEST PROCEDURE	90
5.5.4	DEVIATION FROM TEST STANDARD	90
5.5.5	TEST SETUP	90



5.5.6	EUT OPERATING CONDITION	90
5.5.7	TEST RESULTS	91
5.6	BAND EDGES MEASUREMENT	94
5.6.1	LIMITS OF BAND EDGES MEASUREMENT	94
5.6.2	TEST INSTRUMENTS	94
5.6.3	TEST PROCEDURE	95
5.6.4	DEVIATION FROM TEST STANDARD	95
5.6.5	EUT OPERATING CONDITION	95
5.6.6	TEST RESULTS	96
5.7	ANTENNA REQUIREMENT	99
5.7.1	STANDARD APPLICABLE	99
5.7.2	ANTENNA CONNECTED CONSTRUCTION	99
6.	INFORMATION ON THE TESTING LABORATORIES	100
	APPENDIX-A	A-1



1. CERTIFICATION

PRODUCT: 802.11a/b/g WLAN SDIO Radio Module
BRAND NAME: Symbol Technologies Inc.
MODEL NO.: 21-92955
TEST SAMPLE: ENGINEERING SAMPLE
TESTED: March 20 to 29, 2007
APPLICANT: Symbol Technologies Inc.
STANDARDS: FCC Part 15, Subpart C (Section 15.247),
ANSI C63.4-2003

The above equipment (Model: 21-92955) has been tested by **Advance Data Technology Corporation**, and found compliance with the requirement of the above standards. The test record, data evaluation & Equipment Under Test (EUT) configurations represented herein are true and accurate accounts of the measurements of the sample's EMC characteristics under the conditions specified in this report.

PREPARED BY : Carol Liao , **DATE:** March 29, 2007
(Carol Liao)

TECHNICAL ACCEPTANCE : Moris Lin , **DATE:** March 29, 2007
Responsible for RF (Moris Lin)

APPROVED BY : Hank Chung , **DATE:** March 29, 2007
(Hank Chung, Deputy Manager)

2. SUMMARY OF TEST RESULTS

The EUT has been tested according to the following specifications:

For 802.11b & g, 2412~2462MHz Band

APPLIED STANDARD: FCC Part 15, Subpart C (Section 15.247)			
Standard Section	Test Type and Limit	Result	Remark
15.207	AC Power Conducted Emission	PASS	Meet the requirement of limit. Minimum passing margin is -11.50dB at 16.630MHz
15.247(a)(2)	Spectrum Bandwidth of a Direct Sequence Spread Spectrum System Limit: min. 500kHz	PASS	Meet the requirement of limit.
15.247(b)	Maximum Peak Output Power Limit: max. 30dBm	PASS	Meet the requirement of limit.
15.247(d)	Radiated Emissions Limit: Table 15.209	PASS	Meet the requirement of limit. Minimum passing margin is -0.2dB at 4924.00MHz
15.247(e)	Power Spectral Density Limit: max. 8dBm	PASS	Meet the requirement of limit.
15.247(d)	Band Edge Measurement Limit: 20dB less than the peak value of fundamental frequency	PASS	Meet the requirement of limit.

For 802.11a, 5725~5850MHz Band

APPLIED STANDARD: FCC Part 15, Subpart C (Section 15.247)			
Standard Section	Test Type and Limit	Result	Remark
15.207	AC Power Conducted Emission	PASS	Meet the requirement of limit. Minimum passing margin is -13.53dB at 2.245MHz
15.247(a)(2)	Spectrum Bandwidth of a Direct Sequence Spread Spectrum System Limit: min. 500kHz	PASS	Meet the requirement of limit.
15.247(b)	Maximum Peak Output Power Limit: max. 30dBm	PASS	Meet the requirement of limit.
15.247(d)	Radiated Emissions Limit: Table 15.209	PASS	Meet the requirement of limit. Minimum passing margin is -0.5dB at 11650.00MHz
15.247(e)	Power Spectral Density Limit: max. 8dBm	PASS	Meet the requirement of limit.
15.247(d)	Band Edge Measurement Limit: 20dB less than the peak value of fundamental frequency	PASS	Meet the requirement of limit.

NOTE:

1. The EUT was operating in 2.412 ~ 2.462GHz, 5.15~5.35GHz, 5.47~5.725GHz and 5.725~5.850GHz frequencies band. This report was recorded the RF parameters including 2.412 ~ 2.462GHz and 5.725 ~ 5.850GHz. For the 5.15~5.35GHz and 5.47~5.725GHz RF parameters was recorded in another test report.

2.1 MEASUREMENT UNCERTAINTY

Where relevant, the following measurement uncertainty levels have been estimated for tests performed on the EUT as specified in CISPR 16-4:

This uncertainty represents an expanded uncertainty expressed at approximately the 95% confidence level using a coverage factor of $k=2$.

Measurement	Value
Conducted emissions	2.41 dB
Radiated emissions (30MHz-1GHz)	3.89 dB
Radiated emissions (1GHz -18GHz)	2.21 dB
Radiated emissions (18GHz -40GHz)	1.88 dB

3. GENERAL INFORMATION

3.1 GENERAL DESCRIPTION OF EUT

EUT	802.11a/b/g WLAN SDIO Radio Module
MODEL NO.	21-92955
FCC ID	H9P2192955
POWER SUPPLY	DC 3.3V +/-5% from host equipment
MODULATION TYPE	CCK, DQPSK, DBPSK for DSSS 64QAM, 16QAM, QPSK, BPSK for OFDM
MODULATION TECHNOLOGY	DSSS, OFDM
TRANSFER RATE	802.11b:11/5.5/2/1Mbps 802.11g: 54/48/36/24/18/12/9/6Mbps 802.11a: 54/48/36/24/18/12/9/6Mbps
FREQUENCY RANGE	For 15.407 802.11a: 5.15 ~ 5.35GHz and 5.47 ~ 5.725GHz
	For 15.247 802.11b & 802.11g: 2412 ~ 2462MHz 802.11a: 5.725 ~ 5.850GHz
NUMBER OF CHANNEL	For 15.407 802.11a (5.15 ~ 5.35GHz):8 802.11a (5.47 ~ 5.725GHz):15
	For 15.247 802.11b & 802.11g: 11 802.11a (5.725 ~ 5.850GHz):5
CHANNEL SPACING	802.11b & 802.11g: 5MHz 802.11a: 20MHz
OUTPUT POWER	For 802.11b: 44.668mW For 802.11g: 107.152mW For 802.11a (FCC15.247): 104.713mW For 802.11a (FCC15.407): 34.834mW
DATA CABLE	NA
ANTENNA TYPE	Please see note 3 (on next page)
I/O PORTS	NA
ASSOCIATED DEVICES	NA

NOTE:

1. The EUT operates in both the 5GHz and 2.4GHz Bands and compatibility with 802.11a and 802.11b, 802.11g technology.
2. There are two crystals have been pre-tested in our facility as following:

Mode	Frequency
A	Crystal 1: Brand : RIVER, Model : FCXO-05-40MJ61185
B	Crystal 2: Brand : SWIRD, Model : OSC913200JLS

The function and circuit of above crystals are identical to each other except for the brand.

The worse case was found in mode A. The final test data was recorded in this report.

3. There is one antenna provided to this EUT, please refer to the following table:

Model No.	Symbol P/N	Frequency Range	Gain (dBi)	Cable Loss (dB)	Net Gain (dBi)	Antenna Type	Connector
C802-5100 01-A	ML-2452-A	2.4GHz	3	0.5	2.5	Dipole	RP-SMA MALE
	PA2-01	5GHz	4	1.2	2.8		

4. The above EUT information was declared by the manufacturer and for more detailed features description, please refer to the manufacturer's specifications or User's Manual.

3.2 DESCRIPTION OF TEST MODES

Operated in 2400 ~ 2483.5MHz band:

For 802.11b/g: Eleven channels are provided to this EUT.

Channel	Frequency	Channel	Frequency
1	2412 MHz	7	2442 MHz
2	2417 MHz	8	2447 MHz
3	2422 MHz	9	2452 MHz
4	2427 MHz	10	2457 MHz
5	2432 MHz	11	2462 MHz
6	2437 MHz		

Operated in 5725 ~ 5850MHz band:

For 802.11a (5725 ~ 5850MHz band): Five channels are provided to this EUT.

Channel	Frequency
1	5745 MHz
2	5765 MHz
3	5785 MHz
4	5805 MHz
5	5825 MHz

3.2.1 TEST MODE APPLICABILITY AND TESTED CHANNEL DETAIL:

EUT configure mode	Applicable to				Description
	PLC	RE<1G	RE [≥] 1G	APCM	
-	√	√	√	√	NA

Where PLC: Power Line Conducted Emission RE<1G RE: Radiated Emission below 1GHz
 RE[≥]1G: Radiated Emission above 1GHz APCM: Antenna Port Conducted Measurement

Power Line Conducted Emission Test:

- Pre-Scan has been conducted to determine the worst-case mode from all possible combinations between available modulations, data rates and antenna ports (if EUT with antenna diversity architecture).
- Following channel(s) was (were) selected for the final test as listed below.

Mode	Available Channel	Tested Channel	Modulation Technology	Modulation Type	Data Rate (Mbps)
802.11b	1 to 11	1	DSSS	CCK	1
802.11a	1 to 5	5	OFDM	BPSK	6

Radiated Emission Test (Below 1 GHz):

- Pre-Scan has been conducted to determine the worst-case mode from all possible combinations between available modulations, data rates and antenna ports (if EUT with antenna diversity architecture).
- Following channel(s) was (were) selected for the final test as listed below.

Mode	Available Channel	Tested Channel	Modulation Technology	Modulation Type	Data Rate (Mbps)
802.11b	1 to 11	1	DSSS	CCK	1
802.11a	1 to 5	5	OFDM	BPSK	6

Radiated Emission Test (Above 1 GHz):

- Pre-Scan has been conducted to determine the worst-case mode from all possible combinations between available modulations, data rates and antenna ports (if EUT with antenna diversity architecture).
- Following channel(s) was (were) selected for the final test as listed below.

Mode	Available Channel	Tested Channel	Modulation Technology	Modulation Type	Data Rate (Mbps)
802.11b	1 to 11	1, 6, 11	DSSS	CCK	1
802.11g	1 to 11	1, 2, 6, 10, 11	OFDM	BPSK	6
802.11a	1 to 5	1, 3, 5	OFDM	BPSK	6

Channel 2 and 10 required by manufacture.

Bandedge Measurement:

- Pre-Scan has been conducted to determine the worst-case mode from all possible combinations between available modulations, data rates and antenna ports (if EUT with antenna diversity architecture).
- Following channel(s) was (were) selected for the final test as listed below.

Mode	Available Channel	Tested Channel	Modulation Technology	Modulation Type	Data Rate (Mbps)
802.11b	1 to 11	1, 11	DSSS	CCK	1
802.11g	1 to 11	1, 11, 2, 10	OFDM	BPSK	6
802.11a	1 to 5	1, 5	OFDM	BPSK	6

Channel 2 and 10 required by manufacture.

Antenna Port Conducted Measurement:

- Pre-Scan has been conducted to determine the worst-case mode from all possible combinations between available modulations, data rates and antenna ports (if EUT with antenna diversity architecture).
- Following channel(s) was (were) selected for the final test as listed below.

Mode	Available Channel	Tested Channel	Modulation Technology	Modulation Type	Data Rate (Mbps)
802.11b	1 to 11	1, 6, 11	DSSS	CCK	1
802.11g	1 to 11	1, 2, 6, 10, 11	OFDM	BPSK	6
802.11a	1 to 5	1, 3, 5	OFDM	BPSK	6

Channel 2 and 10 required by manufacture.



3.3 GENERAL DESCRIPTION OF APPLIED STANDARDS

The EUT is an 802.11a/b/g WLAN SDIO Radio Module. According to the specifications of the manufacturer, it must comply with the requirements of the following standards:

FCC Part 15, Subpart C. (15.247)

ANSI C63.4-2003

All test items have been performed and recorded as per the above standards.

NOTE: The EUT is also considered as a kind of computer peripheral, because the connection to computer is necessary for typical use. It has been verified to comply with the requirements of FCC Part 15, Subpart B, Class B (DoC). The test report has been issued separately.

3.4 DESCRIPTION OF SUPPORT UNITS

The EUT has been tested as an independent unit together with other necessary accessories or support units. The following support units or accessories were used to form a representative test configuration during the tests.

NO.	PRODUCT	BRAND	MODEL NO.	SERIAL NO.	FCC ID
1	NOTEBOOK COMPUTER	IBM	2672	9949APL	FCC DoC
2	DC POWER SUPPLY	GW	GPC-30600	7715073	FCC DoC
3	Extend Card	USI	JEDI ADAPTOR BOARD_DVT Rev1.4	NA	NA

NO.	SIGNAL CABLE DESCRIPTION OF THE ABOVE SUPPORT UNITS
1	NA
2	NA
3	NA

NOTE: All power cords of the above support units are non shielded (1.8m).

3.5 CONFIGURATION OF SYSTEM UNDER TEST

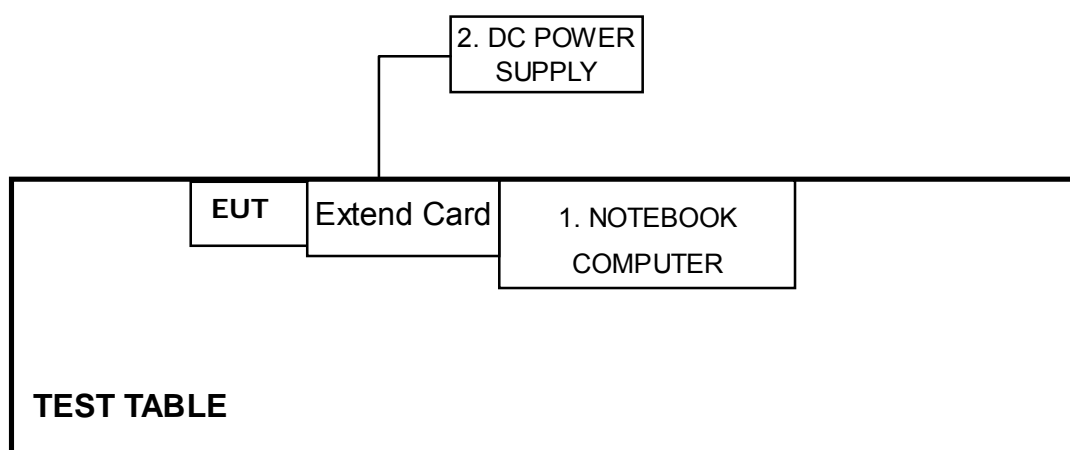

NOTE: 1. Please refer to the photos of test configuration.

4. TEST TYPES AND RESULTS (802.11b & g, 2400 ~ 2483.5MHz Band)

4.1 CONDUCTED EMISSION MEASUREMENT

4.1.1 LIMITS OF CONDUCTED EMISSION MEASUREMENT

FREQUENCY OF EMISSION (MHz)	CONDUCTED LIMIT (dB μ V)	
	Quasi-peak	Average
0.15-0.5	66 to 56	56 to 46
0.5-5	56	46
5-30	60	50

- NOTE:**
1. The lower limit shall apply at the transition frequencies.
 2. The limit decreases in line with the logarithm of the frequency in the range of 0.15 to 0.50 MHz.
 3. All emanations from a class A/B digital device or system, including any network of conductors and apparatus connected thereto, shall not exceed the level of field strengths specified above.

4.1.2 TEST INSTRUMENTS

DESCRIPTION & MANUFACTURER	MODEL NO.	SERIAL NO.	CALIBRATED UNTIL
Test Receiver	ESCS 30	847124/029	Mar. 01, 2008
Line-Impedance Stabilization Network(for EUT)	ENV-216	100071	Nov. 26, 2007
Line-Impedance Stabilization Network(for Peripheral)	ESH3-Z5	848773/004	Oct. 26, 2007
RF Cable (JETBAO)	RG233/U	Cable_CB_01	Dec. 09, 2007
Terminator	50	2	Oct. 30, 2007
Software	ADT_Cond_V7.3.2	NA	NA

- NOTE:**
1. The calibration interval of the above test instruments is 12 months and the calibrations are traceable to NML/ROC and NIST/USA.
 2. The test was performed in ADT Shielded Room No. B.
 3. The VCCI Con B Registration No. is C-2193.

4.1.3 TEST PROCEDURES

- a. The EUT was placed 0.4 meters from the conducting wall of the shielded room with EUT being connected to the power mains through a line impedance stabilization network (LISN). Other support units were connected to the power mains through another LISN. The two LISNs provide 50 ohm/ 50uH of coupling impedance for the measuring instrument.
- b. Both lines of the power mains connected to the EUT were checked for maximum conducted interference.
- c. The frequency range from 150kHz to 30MHz was searched. Emission levels under (Limit - 20dB) were not recorded.

4.1.4 DEVIATION FROM TEST STANDARD

No deviation

4.1.5 TEST SETUP

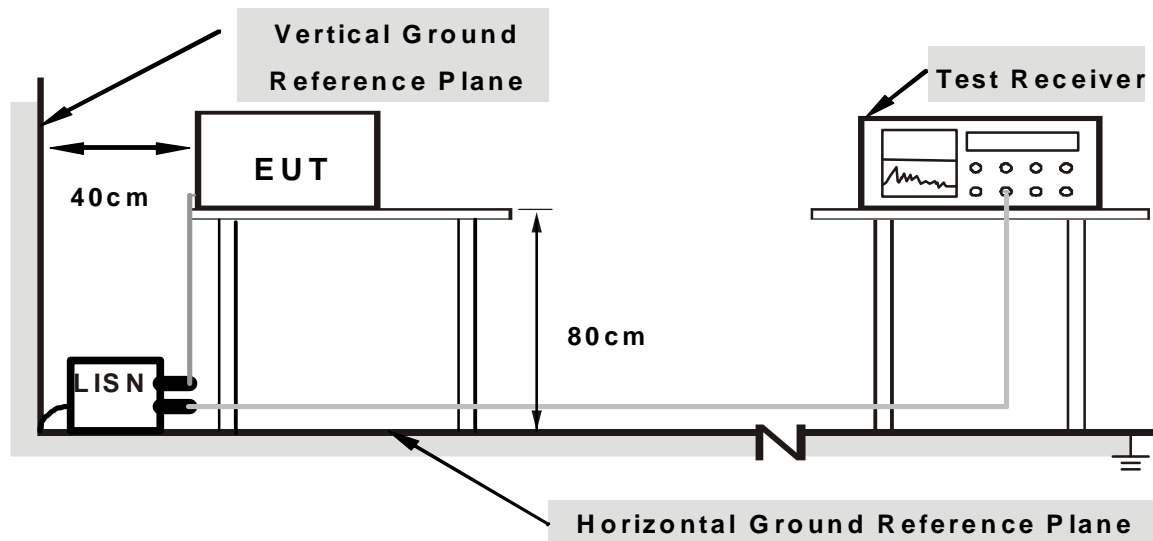

Note: 1. Support units were connected to second LISN.

2. Both of LISNs (AMN) are 80 cm from EUT and at least 80 from other units and other metal planes

For the actual test configuration, please refer to the related item – Photographs of the Test Configuration.

4.1.6 EUT OPERATING CONDITIONS

- a. Connect the EUT with the support unit 1 (Notebook computer) which placed on a testing table.
- b. The support unit 1 (Notebook computer) ran a test program “Prism Engineering” to enable EUT under transmission condition continuously.

4.1.7 TEST RESULTS

Conducted Worst-Case Data

MODULATION TYPE	CCK	6dB BANDWIDTH	9 kHz
INPUT POWER	DC 3.3V	TRANSFER RATE	1Mbps
ENVIRONMENTAL CONDITIONS	20deg. C, 60%RH, 972hPa	PHASE	Positive
TESTED BY	Eric Lee		

No	Freq. [MHz]	Corr. Factor (dB)	Reading Value [dB (uV)]		Emission Level [dB (uV)]		Limit [dB (uV)]		Margin (dB)	
			Q.P.	AV.	Q.P.	AV.	Q.P.	AV.	Q.P.	AV.
			1	0.177	9.60	35.72	-	45.32	-	64.64
2	0.296	9.60	27.16	-	36.76	-	60.36	50.36	-23.60	-
3	0.830	9.60	31.00	-	40.60	-	56.00	46.00	-15.40	-
4	2.245	9.70	32.77	-	42.47	-	56.00	46.00	-13.53	-
5	14.941	10.00	23.83	-	33.83	-	60.00	50.00	-26.17	-
6	20.380	10.10	22.46	-	32.56	-	60.00	50.00	-27.44	-

- REMARKS:**
1. Q.P. and AV. are abbreviations of quasi-peak and average individually.
 2. "-": The Quasi-peak reading value also meets average limit and measurement with the average detector is unnecessary.
 3. The emission levels of other frequencies were very low against the limit.
 4. Margin value = Emission level - Limit value
 5. Correction factor = Insertion loss + Cable loss
 6. Emission Level = Correction Factor + Reading Value.

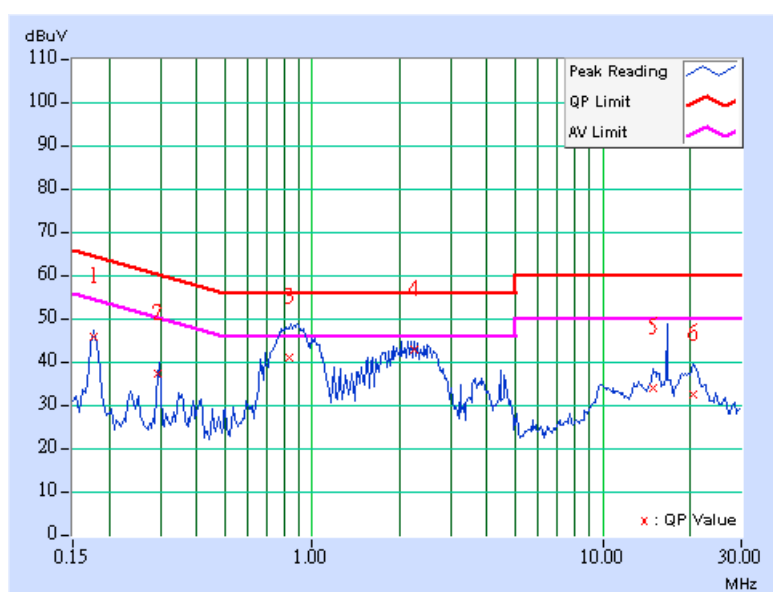

MODULATION TYPE	CCK	6dB BANDWIDTH	9 kHz
INPUT POWER	DC 3.3V	TRANSFER RATE	1Mbps
ENVIRONMENTAL CONDITIONS	20deg. C, 60%RH, 972hPa	PHASE	Negative
TESTED BY	Eric Lee		

No	Freq. [MHz]	Corr. Factor (dB)	Reading Value		Emission Level		Limit		Margin	
			[dB (uV)]		[dB (uV)]		[dB (uV)]		(dB)	
			Q.P.	AV.	Q.P.	AV.	Q.P.	AV.	Q.P.	AV.
1	0.178	9.60	34.39	-	43.99	-	64.58	54.58	-20.59	-
2	0.295	9.60	26.13	-	35.73	-	60.40	50.40	-24.67	-
3	0.849	9.60	31.34	-	40.94	-	56.00	46.00	-15.06	-
4	2.175	9.70	34.21	-	43.91	-	56.00	46.00	-12.09	-
5	16.630	10.10	38.40	-	48.50	-	60.00	50.00	-11.50	-
6	20.384	10.10	24.49	-	34.59	-	60.00	50.00	-25.41	-

- REMARKS:**
1. Q.P. and AV. are abbreviations of quasi-peak and average individually.
 2. "-": The Quasi-peak reading value also meets average limit and measurement with the average detector is unnecessary.
 3. The emission levels of other frequencies were very low against the limit.
 4. Margin value = Emission level - Limit value
 5. Correction factor = Insertion loss + Cable loss
 6. Emission Level = Correction Factor + Reading Value.

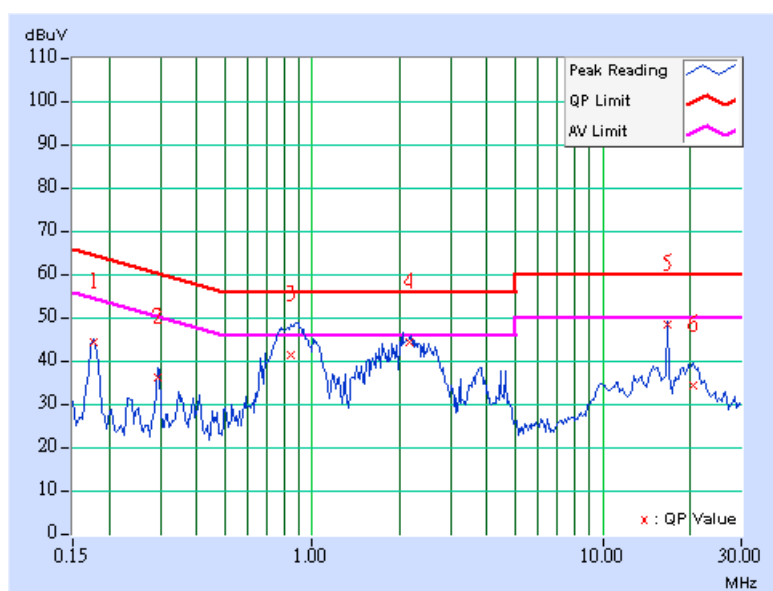

4.2 RADIATED EMISSION MEASUREMENT

4.2.1 LIMITS OF RADIATED EMISSION MEASUREMENT

Emissions radiated outside of the specified bands, shall be according to the general radiated limits in 15.209 as following:

Frequencies (MHz)	Field strength (microvolts/meter)	Measurement distance (meters)
0.009-0.490	2400/F(kHz)	300
0.490-1.705	24000/F(kHz)	30
1.705-30.0	30	30
30-88	100	3
88-216	150	3
216-960	200	3
Above 960	500	3

NOTE:

1. The lower limit shall apply at the transition frequencies.
2. Emission level (dBuV/m) = 20 log Emission level (uV/m).
3. As shown in 15.35(b), for frequencies above 1000MHz, the field strength limits are based on average detector, however, the peak field strength of any emission shall not exceed the maximum permitted average limits, specified above by more than 20dB under any condition of modulation.



4.2.2 TEST INSTRUMENTS

DESCRIPTION & MANUFACTURER	MODEL NO.	SERIAL NO.	CALIBRATED UNTIL
ADVANTEST Spectrum Analyzer	R3271A	85060311	July 03, 2007
HP Pre_Amplifier	8449B	3008A01922	Sep. 18, 2007
ROHDE & SCHWARZ Test Receiver	ESCS30	100375	Sep. 20, 2007
CHASE Broadband Antenna	VULB9168	138	Dec. 10, 2007
Schwarzbeck Horn_Antenna	BBHA9120	D124	Jan. 01, 2008
Schwarzbeck Horn_Antenna	BBHA 9170	BBHA9170153	Jan. 04, 2008
SCHWARZBECK Biconical Antenna	VHBA9123	459	Jun. 08, 2009
SCHWARZBECK Periodic Antenna	UPA6108	1148	Jun. 08, 2009
R&S Loop Antenna	HFH2-Z2	881058/15	Nov. 29, 2007
RF Switches (ARNITSU)	CS-201	1565157	NA
RF CABLE (Chaintek)	SF102	22054-2	Nov. 14, 2007
RF Cable(RICHTEC)	9913-30M N-N Cable	STCCAB-30M-1 GHz	Jul. 15, 2007
Software	ADT_Radiated_V 5.14	NA	NA
CHANCE MOST Antenna Tower	AT-100	0203	NA
CHANCE MOST Turn Table	TT-100	0203	NA

- Note: 1. The calibration interval of the above test instruments is 12 months (36 months for Biconical and Periodic Antenna) and the calibrations are traceable to NML/ROC and NIST/USA.
2. The horn antenna, HP preamplifier (model: 8449B) and Spectrum Analyzer (model: R3271A) are used only for the measurement of emission frequency above 1GHz if tested.
3. The test was performed in ADT Open Site No. C.
4. The FCC Site Registration No. is 656396.
5. The VCCI Site Registration No. is R-1626.
6. The CANADA Site Registration No. is IC 4824A-3.
7. Loop antenna was used for all emissions below 30 MHz.

4.2.3 TEST PROCEDURES

- a. The EUT was placed on the top of a rotating table 0.8 meters above the ground at a 3 meter semi- anechoic. The table was rotated 360 degrees to determine the position of the highest radiation.
- b. The EUT was set 3 meters away from the interference-receiving antenna, which was mounted on the top of a variable-height antenna tower.
- c. The antenna is a broadband antenna, and its height is varied from one meter to four meters above the ground to determine the maximum value of the field strength. Both horizontal and vertical polarizations of the antenna are set to make the measurement.
- d. For each suspected emission, the EUT was arranged to its worst case and then the antenna was tuned to heights from 1 meter to 4 meters and the rotatable table was turned from 0 degrees to 360 degrees to find the maximum reading.
- e. The test-receiver system was set to Peak Detect Function and Specified Bandwidth with Maximum Hold Mode.
- f. If the emission level of the EUT in peak mode was 10 dB lower than the limit specified, then testing could be stopped and the peak values of the EUT would be reported. Otherwise the emissions that did not have 10 dB margin would be re-tested one by one using the quasi-peak method or average method as specified and then reported in Data sheet peak mode and QP mode.

NOTE:

1. The resolution bandwidth and video bandwidth of test receiver/spectrum analyzer is 120kHz for Peak detection (PK) and Quasi-peak detection (QP) at frequency below 1GHz.
2. The resolution bandwidth of test receiver/spectrum analyzer is 1 MHz and the video bandwidth is 3 MHz for Peak detection (PK) at frequency above 1GHz.
3. The resolution bandwidth of test receiver/spectrum analyzer is 1 MHz and the video bandwidth is 10 Hz for Average detection (AV) at frequency above 1GHz.

4.2.4 DEVIATION FROM TEST STANDARD

No deviation

4.2.5 TEST SETUP

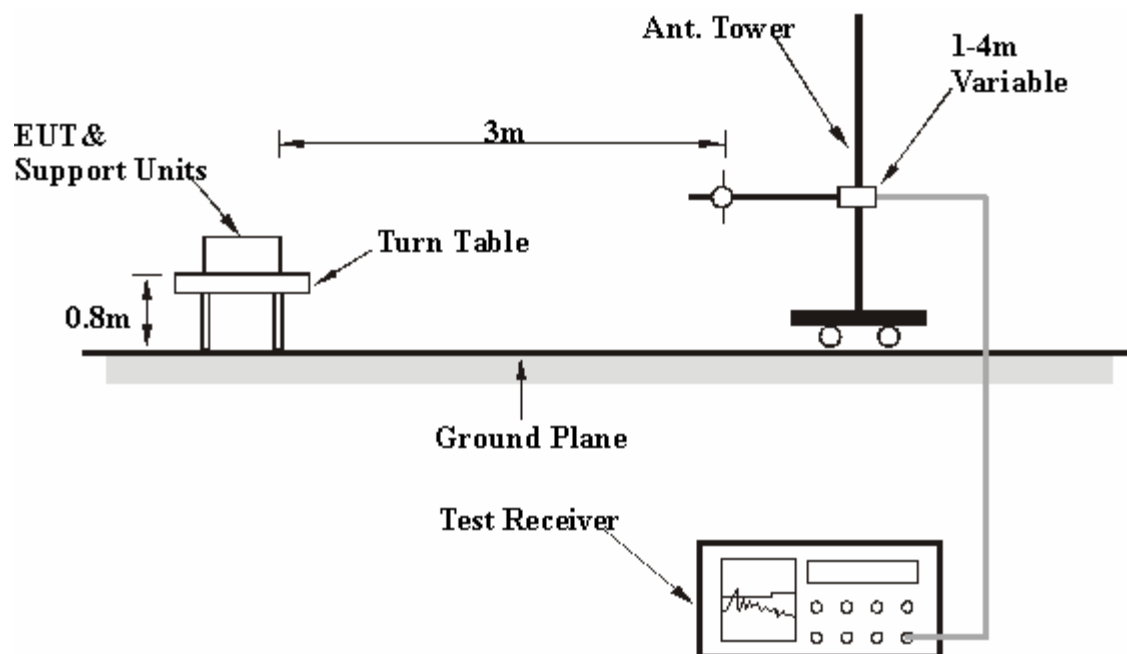

For the actual test configuration, please refer to the related item – Photographs of the Test Configuration.

4.2.6 EUT OPERATING CONDITIONS

Same as 4.1.6

4.2.7 TEST RESULTS

Below 1GHz Worst-Case Data

MODULATION TYPE	CCK	FREQUENCY RANGE	Below 1000MHz
INPUT POWER (SYSTEM)	120Vac, 60 Hz	TRANSFER RATE	1Mbps
ENVIRONMENTAL CONDITIONS	23deg. C, 67%RH, 972hPa	DETECTOR FUNCTION	Quasi-Peak
TESTED BY	Rex Huang		

ANTENNA POLARITY & TEST DISTANCE: HORIZONTAL AT 3 M

No.	Freq. (MHz)	Emission Level (dBuV/m)	Limit (dBuV/m)	Margin (dB)	Antenna Height (m)	Table Angle (Degree)	Raw Value (dBuV)	Correction Factor (dB/m)
1	133.49	26.03 QP	43.50	-17.47	2.01 H	350	13.12	12.91
2	200.11	31.50 QP	43.50	-12.00	1.64 H	234	19.90	11.60
3	233.40	38.91 QP	46.00	-7.09	1.49 H	354	25.85	13.06
4	366.92	40.54 QP	46.00	-5.46	1.00 H	319	22.61	17.93
5	433.20	37.71 QP	46.00	-8.29	1.00 H	165	17.72	19.99
6	533.78	39.32 QP	46.00	-6.68	1.80 H	239	16.56	22.76
7	633.36	35.71 QP	46.00	-10.29	1.55 H	237	10.86	24.85
8	800.00	39.70 QP	46.00	-6.30	1.10 H	307	12.14	27.56
9	933.51	39.07 QP	46.00	-6.93	1.32 H	297	9.53	29.54

ANTENNA POLARITY & TEST DISTANCE: VERTICAL AT 3 M

No.	Freq. (MHz)	Emission Level (dBuV/m)	Limit (dBuV/m)	Margin (dB)	Antenna Height (m)	Table Angle (Degree)	Raw Value (dBuV)	Correction Factor (dB/m)
1	68.86	28.70 QP	40.00	-11.30	1.00 V	222	16.00	12.70
2	133.49	29.30 QP	43.50	-14.20	1.00 V	291	16.39	12.91
3	200.24	28.47 QP	43.50	-15.03	1.00 V	225	16.86	11.61
4	232.99	31.57 QP	46.00	-14.43	1.00 V	269	18.53	13.04
5	366.44	34.51 QP	46.00	-11.49	1.00 V	256	16.59	17.92
6	432.13	36.90 QP	46.00	-9.10	1.00 V	238	16.94	19.96
7	532.90	35.98 QP	46.00	-10.02	1.18 V	263	13.25	22.73
8	633.26	35.19 QP	46.00	-10.81	1.50 V	298	10.34	24.85
9	799.71	35.71 QP	46.00	-10.29	1.38 V	300	8.15	27.56
10	932.76	37.55 QP	46.00	-8.45	1.26 V	255	8.03	29.52

- REMARKS:**
1. Emission level(dBuV/m)=Raw Value(dBuV) + Correction Factor(dB/m)
 2. Correction Factor(dB/m) = Antenna Factor (dB/m) + Cable Factor (dB)
 3. The other emission levels were very low against the limit.
 4. Margin value = Emission level – Limit value

802.11b DSSS modulation

CHANNEL	Channel 1	FREQUENCY RANGE	1 ~ 25GHz
MODULATION TYPE	CCK	TRANSFER RATE	1Mbps
INPUT POWER (SYSTEM)	120Vac, 60 Hz	DETECTOR FUNCTION	Peak(PK) Average (AV)
ENVIRONMENTAL CONDITIONS	15deg. C, 60%RH, 972hPa	TESTED BY	Wen Yu

ANTENNA POLARITY & TEST DISTANCE: HORIZONTAL AT 3 M

No.	Freq. (MHz)	Emission Level (dBuV/m)	Limit (dBuV/m)	Margin (dB)	Antenna Height (m)	Table Angle (Degree)	Raw Value (dBuV)	Correction Factor (dB/m)
1	2390.00	50.80 PK	74.00	-23.20	1.44 H	86	18.90	31.90
1	2390.00	40.80 AV	54.00	-13.20	1.44 H	86	8.90	31.90
2	*2412.00	100.70 PK			1.44 H	86	68.70	32.00
2	*2412.00	95.80 AV			1.44 H	86	63.80	32.00
3	4824.00	47.70 PK	74.00	-26.30	1.60 H	306	11.70	36.00
3	4824.00	38.60 AV	54.00	-15.40	1.60 H	306	2.60	36.00
4	7236.00	52.40 PK	74.00	-21.60	1.28 H	13	10.20	42.20
4	7236.00	39.50 AV	54.00	-14.50	1.28 H	13	-2.70	42.20

ANTENNA POLARITY & TEST DISTANCE: VERTICAL AT 3 M

No.	Freq. (MHz)	Emission Level (dBuV/m)	Limit (dBuV/m)	Margin (dB)	Antenna Height (m)	Table Angle (Degree)	Raw Value (dBuV)	Correction Factor (dB/m)
1	2390.00	60.40 PK	74.00	-13.60	1.76 V	278	28.50	31.90
1	2390.00	50.70 AV	54.00	-3.30	1.76 V	278	18.80	31.90
2	*2412.00	110.30 PK			1.76 V	278	78.30	32.00
2	*2412.00	105.70 AV			1.76 V	278	73.70	32.00
3	4824.00	54.40 PK	74.00	-19.60	1.32 V	72	18.40	36.00
3	4824.00	51.00 AV	54.00	-3.00	1.32 V	72	15.00	36.00
4	7236.00	54.20 PK	74.00	-19.80	1.21 V	0	12.00	42.20
4	7236.00	41.30 AV	54.00	-12.70	1.21 V	0	-0.90	42.20

- REMARKS:**
1. Emission level(dBuV/m)=Raw Value(dBuV) + Correction Factor(dB/m)
 2. Correction Factor(dB/m) = Antenna Factor (dB/m) + Cable Factor (dB)
 3. The other emission levels were very low against the limit.
 4. Margin value = Emission level – Limit value.
 5. The limit value is defined as per 15.247
 6. “ * “ : Fundamental frequency

CHANNEL	Channel 6	FREQUENCY RANGE	1 ~ 25GHz
MODULATION TYPE	CCK	TRANSFER RATE	1Mbps
INPUT POWER (SYSTEM)	120Vac, 60 Hz	DETECTOR FUNCTION	Peak(PK) Average (AV)
ENVIRONMENTAL CONDITIONS	15deg. C, 60%RH, 972hPa	TESTED BY	Wen Yu

ANTENNA POLARITY & TEST DISTANCE: HORIZONTAL AT 3 M

No.	Freq. (MHz)	Emission Level (dBuV/m)	Limit (dBuV/m)	Margin (dB)	Antenna Height (m)	Table Angle (Degree)	Raw Value (dBuV)	Correction Factor (dB/m)
1	*2437.00	100.10 PK			1.43 H	96	68.00	32.10
1	*2437.00	95.40 AV			1.43 H	96	63.30	32.10
2	4874.00	47.00 PK	74.00	-27.00	1.62 H	3	10.90	36.10
2	4874.00	37.10 AV	54.00	-16.90	1.62 H	3	1.00	36.10
3	7311.00	51.40 PK	74.00	-22.60	1.37 H	27	8.90	42.50
3	7311.00	39.40 AV	54.00	-14.60	1.37 H	27	-3.10	42.50

ANTENNA POLARITY & TEST DISTANCE: VERTICAL AT 3 M

No.	Freq. (MHz)	Emission Level (dBuV/m)	Limit (dBuV/m)	Margin (dB)	Antenna Height (m)	Table Angle (Degree)	Raw Value (dBuV)	Correction Factor (dB/m)
1	*2437.00	109.60 PK			1.73 V	276	77.50	32.10
1	*2437.00	105.00 AV			1.73 V	276	72.90	32.10
2	4874.00	53.30 PK	74.00	-20.70	1.15 V	71	17.20	36.10
2	4874.00	49.10 AV	54.00	-4.90	1.15 V	71	13.00	36.10
3	7311.00	53.60 PK	74.00	-20.40	1.35 V	86	11.10	42.50
3	7311.00	41.50 AV	54.00	-12.50	1.35 V	86	-1.00	42.50

- REMARKS:**
1. Emission level(dBuV/m)=Raw Value(dBuV) + Correction Factor(dB/m)
 2. Correction Factor(dB/m) = Antenna Factor (dB/m) + Cable Factor (dB)
 3. The other emission levels were very low against the limit.
 4. Margin value = Emission level – Limit value.
 5. The limit value is defined as per 15.247
 6. “ * “ : Fundamental frequency

CHANNEL	Channel 11	FREQUENCY RANGE	1 ~ 25GHz
MODULATION TYPE	CCK	TRANSFER RATE	1Mbps
INPUT POWER (SYSTEM)	120Vac, 60 Hz	DETECTOR FUNCTION	Peak(PK) Average (AV)
ENVIRONMENTAL CONDITIONS	15deg. C, 60%RH, 972hPa	TESTED BY	Wen Yu

ANTENNA POLARITY & TEST DISTANCE: HORIZONTAL AT 3 M

No.	Freq. (MHz)	Emission Level (dBuV/m)	Limit (dBuV/m)	Margin (dB)	Antenna Height (m)	Table Angle (Degree)	Raw Value (dBuV)	Correction Factor (dB/m)
1	*2462.00	98.30 PK			1.41 H	101	66.10	32.20
1	*2462.00	93.30 AV			1.41 H	101	61.10	32.20
2	2483.50	47.80 PK	74.00	-26.20	1.41 H	101	15.50	32.30
2	2483.50	37.30 AV	54.00	-16.70	1.41 H	101	5.00	32.30
3	4924.00	48.70 PK	74.00	-25.30	1.20 H	126	12.50	36.20
3	4924.00	40.30 AV	54.00	-13.70	1.20 H	126	4.10	36.20
4	7386.00	52.60 PK	74.00	-21.40	1.18 H	21	9.80	42.80
4	7386.00	39.50 AV	54.00	-14.50	1.18 H	21	-3.30	42.80

ANTENNA POLARITY & TEST DISTANCE: VERTICAL AT 3 M

No.	Freq. (MHz)	Emission Level (dBuV/m)	Limit (dBuV/m)	Margin (dB)	Antenna Height (m)	Table Angle (Degree)	Raw Value (dBuV)	Correction Factor (dB/m)
1	*2462.00	109.10 PK			1.71 V	245	76.90	32.20
1	*2462.00	104.70 AV			1.71 V	245	72.50	32.20
2	2483.50	58.60 PK	74.00	-15.40	1.71 V	245	26.30	32.30
2	2483.50	48.70 AV	54.00	-5.30	1.71 V	245	16.40	32.30
3	4924.00	56.80 PK	74.00	-17.20	1.29 V	78	20.60	36.20
3	4924.00	53.80 AV	54.00	-0.20	1.29 V	78	17.60	36.20
4	7386.00	53.40 PK	74.00	-20.60	1.17 V	16	10.60	42.80
4	7386.00	39.60 AV	54.00	-14.40	1.17 V	16	-3.20	42.80

- REMARKS:**
1. Emission level(dBuV/m)=Raw Value(dBuV) + Correction Factor(dB/m)
 2. Correction Factor(dB/m) = Antenna Factor (dB/m) + Cable Factor (dB)
 3. The other emission levels were very low against the limit.
 4. Margin value = Emission level – Limit value.
 5. The limit value is defined as per 15.247
 6. “ * “ : Fundamental frequency

802.11g OFDM modulation

CHANNEL	Channel 1	FREQUENCY RANGE	1 ~ 25GHz
MODULATION TYPE	BPSK	TRANSFER RATE	6Mbps
INPUT POWER (SYSTEM)	120Vac, 60 Hz	DETECTOR FUNCTION	Peak(PK) Average (AV)
ENVIRONMENTAL CONDITIONS	15deg. C, 60%RH, 972hPa	TESTED BY	Wen Yu

ANTENNA POLARITY & TEST DISTANCE: HORIZONTAL AT 3 M

No.	Freq. (MHz)	Emission Level (dBuV/m)	Limit (dBuV/m)	Margin (dB)	Antenna Height (m)	Table Angle (Degree)	Raw Value (dBuV)	Correction Factor (dB/m)
1	2390.00	61.60 PK	74.00	-12.40	1.43 H	164	29.70	31.90
1	2390.00	41.50 AV	54.00	-12.50	1.43 H	164	9.60	31.90
2	*2412.00	99.10 PK			1.43 H	164	67.10	32.00
2	*2412.00	88.40 AV			1.43 H	164	56.40	32.00
3	4824.00	46.80 PK	74.00	-27.20	1.00 H	282	10.80	36.00
3	4824.00	33.20 AV	54.00	-20.80	1.00 H	282	-2.80	36.00
4	7236.00	53.00 PK	74.00	-21.00	1.02 H	308	10.80	42.20
4	7236.00	39.60 AV	54.00	-14.40	1.02 H	308	-2.60	42.20

ANTENNA POLARITY & TEST DISTANCE: VERTICAL AT 3 M

No.	Freq. (MHz)	Emission Level (dBuV/m)	Limit (dBuV/m)	Margin (dB)	Antenna Height (m)	Table Angle (Degree)	Raw Value (dBuV)	Correction Factor (dB/m)
1	2390.00	71.60 PK	74.00	-2.40	1.72 V	308	39.70	31.90
1	2390.00	52.90 AV	54.00	-1.10	1.72 V	308	21.00	31.90
2	*2412.00	109.10 PK			1.72 V	308	77.10	32.00
2	*2412.00	99.80 AV			1.72 V	308	67.80	32.00
3	4824.00	59.50 PK	74.00	-14.50	1.20 V	268	23.50	36.00
3	4824.00	42.10 AV	54.00	-11.90	1.20 V	268	6.10	36.00
4	7236.00	52.00 PK	74.00	-22.00	1.12 V	335	9.80	42.20
4	7236.00	38.90 AV	54.00	-15.10	1.12 V	335	-3.30	42.20

- REMARKS:**
1. Emission level(dBuV/m)=Raw Value(dBuV) + Correction Factor(dB/m)
 2. Correction Factor(dB/m) = Antenna Factor (dB/m) + Cable Factor (dB)
 3. The other emission levels were very low against the limit.
 4. Margin value = Emission level – Limit value.
 5. The limit value is defined as per 15.247
 6. “ * “ : Fundamental frequency

CHANNEL	Channel 2	FREQUENCY RANGE	1 ~ 25GHz
MODULATION TYPE	BPSK	TRANSFER RATE	6Mbps
INPUT POWER (SYSTEM)	120Vac, 60 Hz	DETECTOR FUNCTION	Peak(PK) Average (AV)
ENVIRONMENTAL CONDITIONS	15deg. C, 60%RH, 972hPa	TESTED BY	Wen Yu

ANTENNA POLARITY & TEST DISTANCE: HORIZONTAL AT 3 M

No.	Freq. (MHz)	Emission Level (dBuV/m)	Limit (dBuV/m)	Margin (dB)	Antenna Height (m)	Table Angle (Degree)	Raw Value (dBuV)	Correction Factor (dB/m)
1	2390.00	62.60 PK	74.00	-11.40	1.43 H	144	30.70	31.90
1	2390.00	43.00 AV	54.00	-11.00	1.43 H	144	11.10	31.90
2	*2417.00	102.20 PK			1.43 H	144	70.20	32.00
2	*2417.00	91.50 AV			1.43 H	144	59.50	32.00
3	4834.00	46.80 PK	74.00	-27.20	1.00 H	325	10.80	36.00
3	4834.00	33.60 AV	54.00	-20.40	1.00 H	325	-2.40	36.00
4	7251.00	53.40 PK	74.00	-20.60	1.00 H	338	11.10	42.30
4	7251.00	39.60 AV	54.00	-14.40	1.00 H	338	-2.70	42.30

ANTENNA POLARITY & TEST DISTANCE: VERTICAL AT 3 M

No.	Freq. (MHz)	Emission Level (dBuV/m)	Limit (dBuV/m)	Margin (dB)	Antenna Height (m)	Table Angle (Degree)	Raw Value (dBuV)	Correction Factor (dB/m)
1	2390.00	72.00 PK	74.00	-2.00	1.73 V	255	40.10	31.90
1	2390.00	53.70 AV	54.00	-0.30	1.73 V	255	21.80	31.90
2	*2417.00	111.60 PK			1.73 V	255	79.60	32.00
2	*2417.00	102.20 AV			1.73 V	255	70.20	32.00
3	4834.00	62.40 PK	74.00	-11.60	1.22 V	256	26.40	36.00
3	4834.00	47.10 AV	54.00	-6.90	1.22 V	256	11.10	36.00
4	7251.00	53.30 PK	74.00	-20.70	1.35 V	322	11.00	42.30
4	7251.00	39.80 AV	54.00	-14.20	1.35 V	322	-2.50	42.30

- REMARKS:**
1. Emission level(dBuV/m)=Raw Value(dBuV) + Correction Factor(dB/m)
 2. Correction Factor(dB/m) = Antenna Factor (dB/m) + Cable Factor (dB)
 3. The other emission levels were very low against the limit.
 4. Margin value = Emission level – Limit value.
 5. The limit value is defined as per 15.247
 6. “ * “ : Fundamental frequency
 - 7.Channel 2 and 10 required by manufacture.

CHANNEL	Channel 6	FREQUENCY RANGE	1 ~ 25GHz
MODULATION TYPE	BPSK	TRANSFER RATE	6Mbps
INPUT POWER (SYSTEM)	120Vac, 60 Hz	DETECTOR FUNCTION	Peak(PK) Average (AV)
ENVIRONMENTAL CONDITIONS	15deg. C, 60%RH, 972hPa	TESTED BY	Wen Yu

ANTENNA POLARITY & TEST DISTANCE: HORIZONTAL AT 3 M

No.	Freq. (MHz)	Emission Level (dBuV/m)	Limit (dBuV/m)	Margin (dB)	Antenna Height (m)	Table Angle (Degree)	Raw Value (dBuV)	Correction Factor (dB/m)
1	*2437.00	104.20 PK			1.43 H	95	72.10	32.10
1	*2437.00	94.00 AV			1.43 H	95	61.90	32.10
2	4874.00	47.60 PK	74.00	-26.40	1.00 H	304	11.50	36.10
2	4874.00	33.80 AV	54.00	-20.20	1.00 H	304	-2.30	36.10
3	7311.00	53.60 PK	74.00	-20.40	1.00 H	325	11.10	42.50
3	7311.00	39.80 AV	54.00	-14.20	1.00 H	325	-2.70	42.50

ANTENNA POLARITY & TEST DISTANCE: VERTICAL AT 3 M

No.	Freq. (MHz)	Emission Level (dBuV/m)	Limit (dBuV/m)	Margin (dB)	Antenna Height (m)	Table Angle (Degree)	Raw Value (dBuV)	Correction Factor (dB/m)
1	*2437.00	114.30 PK			1.72 V	72	82.20	32.10
1	*2437.00	103.60 AV			1.72 V	72	71.50	32.10
2	4874.00	64.30 PK	74.00	-9.70	1.20 V	255	28.20	36.10
2	4874.00	49.00 AV	54.00	-5.00	1.20 V	255	12.90	36.10
3	7311.00	54.40 PK	74.00	-19.60	1.39 V	320	11.90	42.50
3	7311.00	40.30 AV	54.00	-13.70	1.39 V	320	-2.20	42.50

- REMARKS:**
1. Emission level(dBuV/m)=Raw Value(dBuV) + Correction Factor(dB/m)
 2. Correction Factor(dB/m) = Antenna Factor (dB/m) + Cable Factor (dB)
 3. The other emission levels were very low against the limit.
 4. Margin value = Emission level – Limit value.
 5. The limit value is defined as per 15.247
 6. “ * “ : Fundamental frequency

CHANNEL	Channel 10	FREQUENCY RANGE	1 ~ 25GHz
MODULATION TYPE	BPSK	TRANSFER RATE	6Mbps
INPUT POWER (SYSTEM)	120Vac, 60 Hz	DETECTOR FUNCTION	Peak(PK) Average (AV)
ENVIRONMENTAL CONDITIONS	15deg. C, 60%RH, 972hPa	TESTED BY	Wen Yu

ANTENNA POLARITY & TEST DISTANCE: HORIZONTAL AT 3 M

No.	Freq. (MHz)	Emission Level (dBuV/m)	Limit (dBuV/m)	Margin (dB)	Antenna Height (m)	Table Angle (Degree)	Raw Value (dBuV)	Correction Factor (dB/m)
1	*2457.00	101.50 PK			1.44 H	99	69.30	32.20
1	*2457.00	90.90 AV			1.44 H	99	58.70	32.20
2	2483.50	64.70 PK	74.00	-9.30	1.44 H	99	32.40	32.30
2	2483.50	43.40 AV	54.00	-10.60	1.44 H	99	11.10	32.30
3	4914.00	47.30 PK	74.00	-26.70	1.00 H	298	11.10	36.20
3	4914.00	33.40 AV	54.00	-20.60	1.00 H	298	-2.80	36.20
4	7371.00	53.10 PK	74.00	-20.90	1.00 H	326	10.40	42.70
4	7371.00	39.30 AV	54.00	-14.70	1.00 H	326	-3.40	42.70

ANTENNA POLARITY & TEST DISTANCE: VERTICAL AT 3 M

No.	Freq. (MHz)	Emission Level (dBuV/m)	Limit (dBuV/m)	Margin (dB)	Antenna Height (m)	Table Angle (Degree)	Raw Value (dBuV)	Correction Factor (dB/m)
1	*2457.00	109.80 PK			1.73 V	64	77.60	32.20
1	*2457.00	100.40 AV			1.73 V	64	68.20	32.20
2	2483.50	73.00 PK	74.00	-1.00	1.73 V	64	40.70	32.30
2	2483.50	52.90 AV	54.00	-1.10	1.73 V	64	20.60	32.30
3	4914.00	64.20 PK	74.00	-9.80	1.22 V	245	28.00	36.20
3	4914.00	48.70 AV	54.00	-5.30	1.22 V	245	12.50	36.20
4	7371.00	53.40 PK	74.00	-20.60	1.38 V	325	10.70	42.70
4	7371.00	39.30 AV	54.00	-14.70	1.38 V	325	-3.40	42.70

- REMARKS:**
1. Emission level(dBuV/m)=Raw Value(dBuV) + Correction Factor(dB/m)
 2. Correction Factor(dB/m) = Antenna Factor (dB/m) + Cable Factor (dB)
 3. The other emission levels were very low against the limit.
 4. Margin value = Emission level – Limit value.
 5. The limit value is defined as per 15.247
 6. “ * “ : Fundamental frequency
 7. Channel 2 and 10 required by manufacture.

CHANNEL	Channel 11	FREQUENCY RANGE	1 ~ 25GHz
MODULATION TYPE	BPSK	TRANSFER RATE	6Mbps
INPUT POWER (SYSTEM)	120Vac, 60 Hz	DETECTOR FUNCTION	Peak(PK) Average (AV)
ENVIRONMENTAL CONDITIONS	15deg. C, 60%RH, 972hPa	TESTED BY	Wen Yu

ANTENNA POLARITY & TEST DISTANCE: HORIZONTAL AT 3 M

No.	Freq. (MHz)	Emission Level (dBuV/m)	Limit (dBuV/m)	Margin (dB)	Antenna Height (m)	Table Angle (Degree)	Raw Value (dBuV)	Correction Factor (dB/m)
1	*2462.00	100.10 PK			1.44 H	100	67.90	32.20
1	*2462.00	89.70 AV			1.44 H	100	57.50	32.20
2	2483.50	64.10 PK	74.00	-9.90	1.44 H	100	31.80	32.30
2	2483.50	43.30 AV	54.00	-10.70	1.44 H	100	11.00	32.30
3	4924.00	46.50 PK	74.00	-27.50	1.00 H	211	10.30	36.20
3	4924.00	32.90 AV	54.00	-21.10	1.00 H	211	-3.30	36.20
4	7386.00	52.90 PK	74.00	-21.10	1.00 H	352	10.10	42.80
4	7386.00	39.40 AV	54.00	-14.60	1.00 H	352	-3.40	42.80

ANTENNA POLARITY & TEST DISTANCE: VERTICAL AT 3 M

No.	Freq. (MHz)	Emission Level (dBuV/m)	Limit (dBuV/m)	Margin (dB)	Antenna Height (m)	Table Angle (Degree)	Raw Value (dBuV)	Correction Factor (dB/m)
1	*2462.00	108.50 PK			1.73 V	64	76.30	32.20
1	*2462.00	99.00 AV			1.73 V	64	66.80	32.20
2	2483.50	72.50 PK	74.00	-1.50	1.73 V	64	40.20	32.30
2	2483.50	52.60 AV	54.00	-1.40	1.73 V	64	20.30	32.30
3	4924.00	57.20 PK	74.00	-16.80	1.32 V	291	21.00	36.20
3	4924.00	42.40 AV	54.00	-11.60	1.32 V	291	6.20	36.20
4	7386.00	52.80 PK	74.00	-21.20	1.46 V	288	10.00	42.80
4	7386.00	39.90 AV	54.00	-14.10	1.46 V	288	-2.90	42.80

- REMARKS:**
1. Emission level(dBuV/m)=Raw Value(dBuV) + Correction Factor(dB/m)
 2. Correction Factor(dB/m) = Antenna Factor (dB/m) + Cable Factor (dB)
 3. The other emission levels were very low against the limit.
 4. Margin value = Emission level – Limit value.
 5. The limit value is defined as per 15.247
 6. “ * “ : Fundamental frequency



4.3 6dB BANDWIDTH MEASUREMENT

4.3.1 LIMITS OF 6dB BANDWIDTH MEASUREMENT

The minimum of 6dB Bandwidth Measurement is 0.5 MHz.

4.3.2 TEST INSTRUMENTS

Description & Manufacturer	Model No.	Serial No.	Calibrated Until
R&S SPECTRUM ANALYZER	FSP40	100037	Aug. 15, 2007

NOTE:

- 1.The measurement uncertainty is less than +/- 2.6dB, which is calculated as per the NAMAS document NIS81. This uncertainty represents an expanded uncertainty expressed at approximately the 95% confidence level using a coverage factor of k=2.
- 2.The calibration interval of the above test instruments is 12 months and the calibrations are traceable to NML/ROC and NIST/USA.

4.3.3 TEST PROCEDURE

The transmitter output was connected to the spectrum analyzer through an attenuator. The bandwidth of the fundamental frequency was measured by spectrum analyzer with 100kHz RBW and 100kHz VBW. The 6dB bandwidth is defined as the total spectrum the power of which is higher than peak power minus 6dB.

4.3.4 DEVIATION FROM TEST STANDARD

No deviation

4.3.5 TEST SETUP

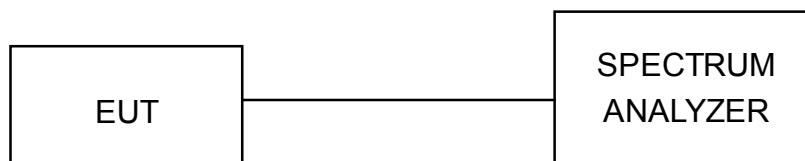

4.3.6 EUT OPERATING CONDITIONS

The software provided by client to enable the EUT under transmission condition continuously at lowest, middle and highest channel frequencies individually.

4.3.7 TEST RESULTS

802.11b DSSS modulation

MODULATION TYPE	CCK	TRANSFER RATE	1Mbps
INPUT POWER (SYSTEM)	120Vac, 60 Hz	ENVIRONMENTAL CONDITIONS	18deg. C, 62%RH, 972hPa
TESTED BY	Wen Yu		

CHANNEL	CHANNEL FREQUENCY (MHz)	6dB BANDWIDTH (MHz)	MINIMUM LIMIT (MHz)	PASS/FAIL
1	2412	11.55	0.5	PASS
6	2437	11.55	0.5	PASS
11	2462	11.55	0.5	PASS

CH1

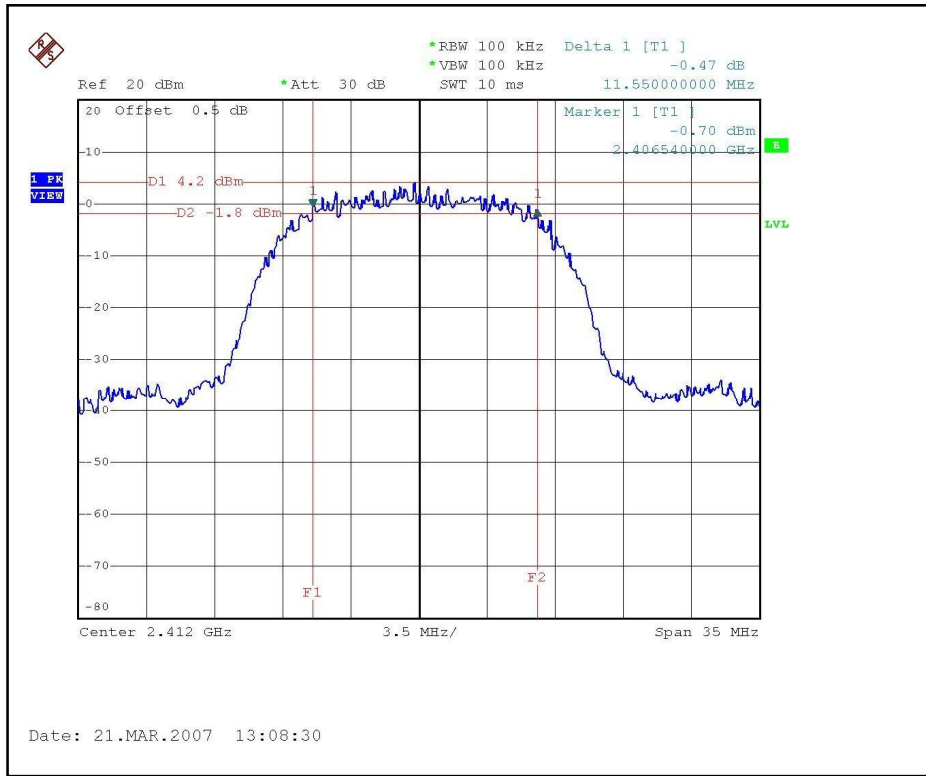

CH6

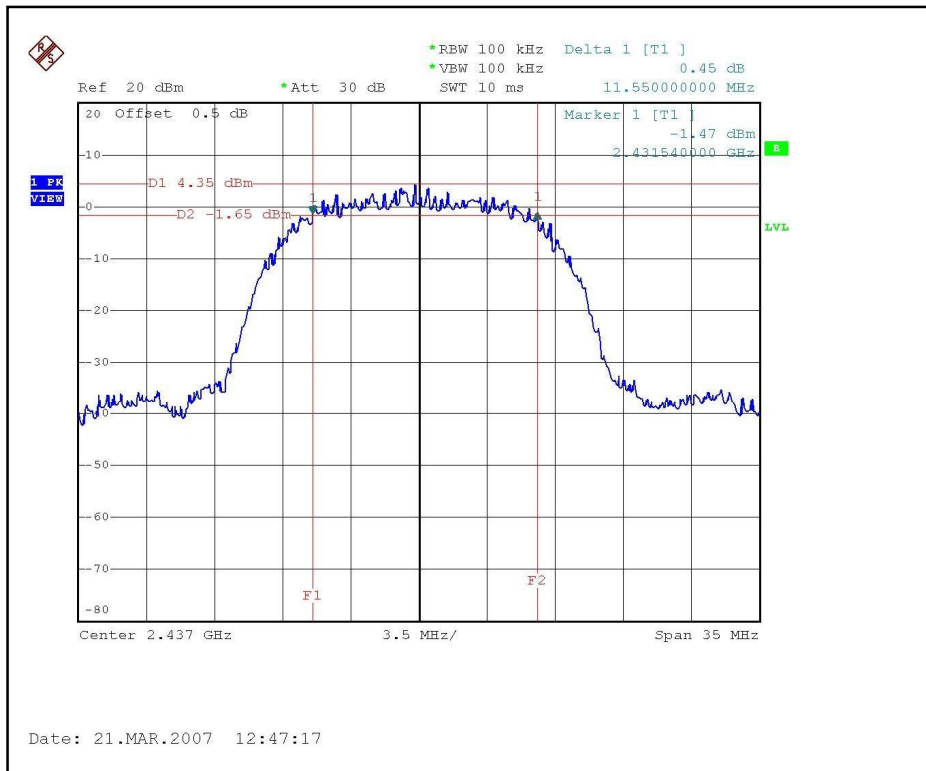

CH11

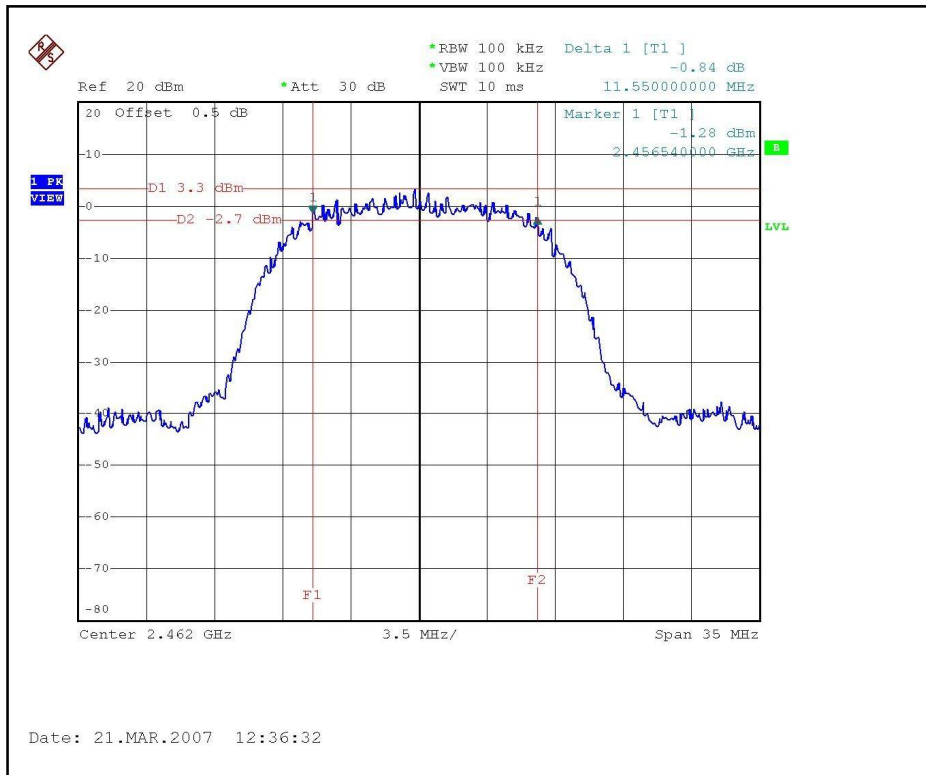



802.11g OFDM modulation

MODULATION TYPE	BPSK	TRANSFER RATE	6Mbps
INPUT POWER (SYSTEM)	120Vac, 60 Hz	ENVIRONMENTAL CONDITIONS	18deg. C, 62%RH, 972hPa
TESTED BY	Wen Yu		

CHANNEL	CHANNEL FREQUENCY (MHz)	6dB BANDWIDTH (MHz)	MINIMUM LIMIT (MHz)	PASS/FAIL
1	2412	16.52	0.5	PASS
6	2437	16.52	0.5	PASS
11	2462	16.52	0.5	PASS

CH1

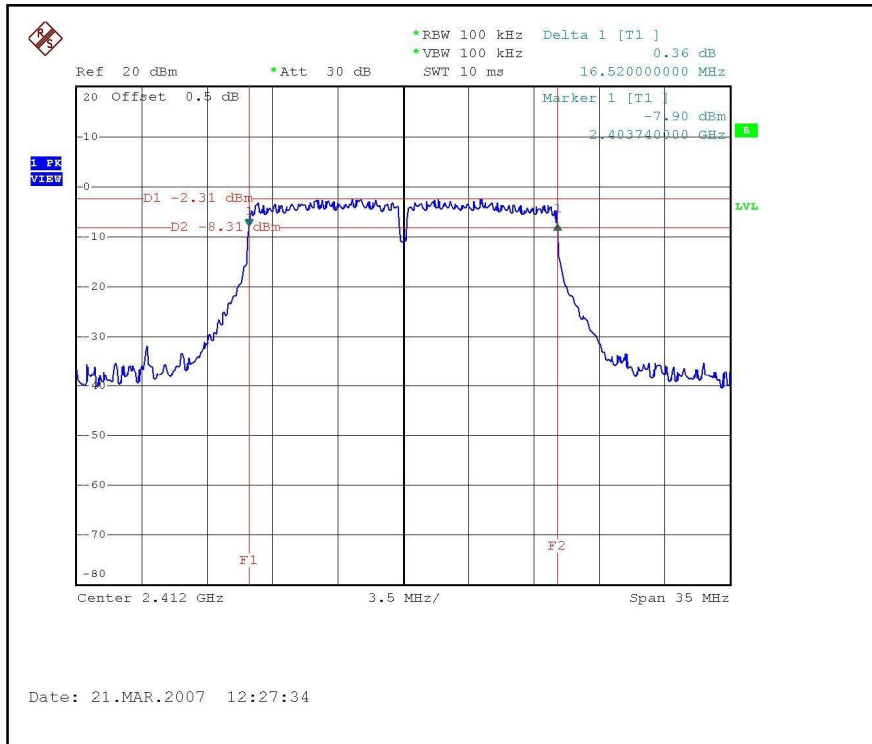

CH6

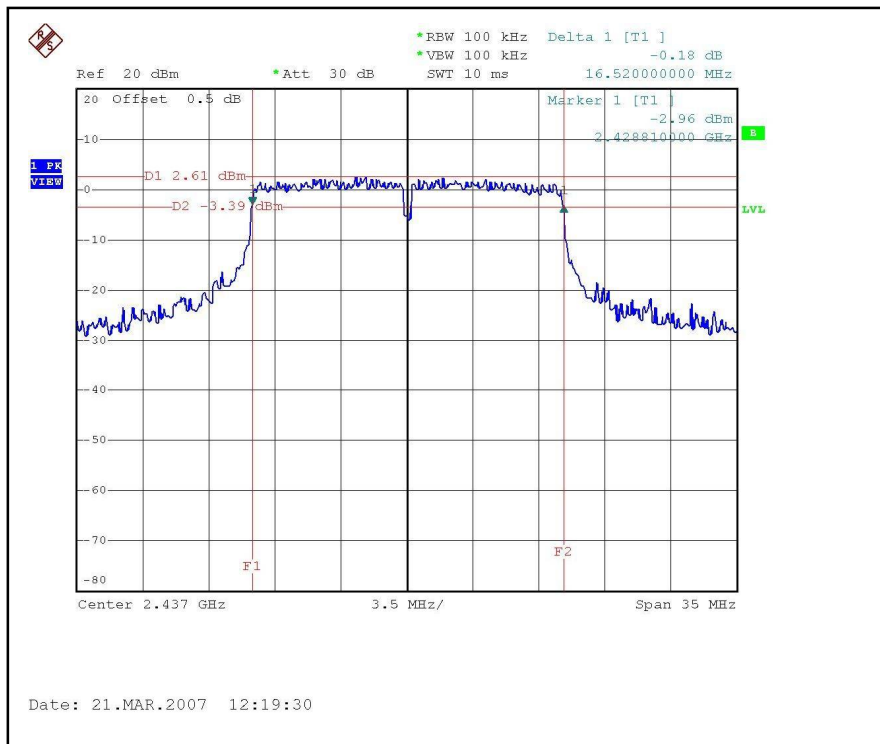

CH11

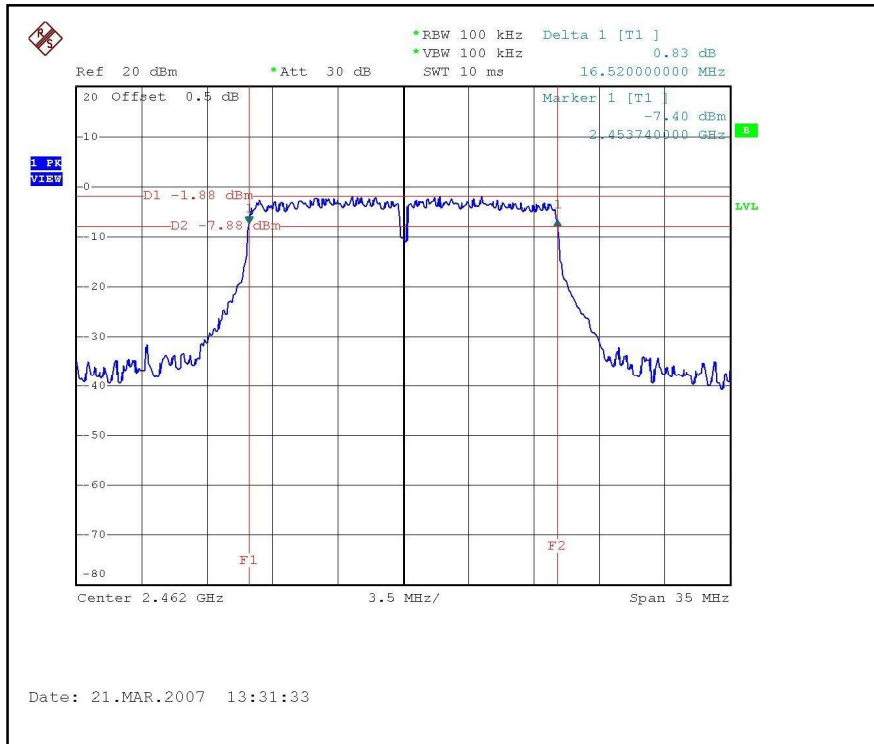



4.4 MAXIMUM PEAK OUTPUT POWER

4.4.1 LIMITS OF MAXIMUM PEAK OUTPUT POWER MEASUREMENT

The Maximum Peak Output Power Measurement is 30dBm.

4.4.2 INSTRUMENTS

Description & Manufacturer	Model No.	Serial No.	Calibrated Until
R&S SPECTRUM ANALYZER	FSP40	100037	Aug. 15, 2007
Agilent SIGNAL GENERATOR	E8257C	MY43320668	Dec. 07, 2007
TEKTRONIX OSCILLOSCOPE	TDS380	B016335	Jul. 04, 2007
NARDA DETECTOR	4503A	FSCM99899	NA

NOTE:

The calibration interval of the above test instruments is 12 months and the calibrations are traceable to NML/ROC and NIST/USA.

4.4.3 TEST PROCEDURES

1. A detector was used on the output port of the EUT. An oscilloscope was used to read the response of the detector.
2. Replaced the EUT by the signal generator. The center frequency of the S.G was adjusted to the center frequency of the measured channel.
3. Adjusted the power to have the same reading on oscilloscope. Record the power level.

4.4.4 DEVIATION FROM TEST STANDARD

No deviation

4.4.5 TEST SETUP



4.4.6 EUT OPERATING CONDITIONS

Same as Item 4.3.6



4.4.7 TEST RESULTS

802.11b DSSS modulation

MODULATION TYPE	CCK	TRANSFER RATE	1Mbps
INPUT POWER (SYSTEM)	120Vac, 60Hz	ENVIRONMENTAL CONDITIONS	18deg. C, 62%RH, 972hPa
TESTED BY	Wen Yu		

CHANNEL	CHANNEL FREQUENCY (MHz)	PEAK POWER OUTPUT (mW)	PEAK POWER OUTPUT (dBm)	PEAK POWER LIMIT (dBm)	PASS/FAIL
1	2412	43.652	16.40	30	PASS
6	2437	43.652	16.40	30	PASS
11	2462	44.668	16.50	30	PASS



802.11g OFDM modulation

MODULATION TYPE	BPSK	TRANSFER RATE	6Mbps
INPUT POWER (SYSTEM)	120Vac, 60Hz	ENVIRONMENTAL CONDITIONS	18deg. C, 62%RH, 972hPa
TESTED BY	Wen Yu		

CHANNEL	CHANNEL FREQUENCY (MHz)	PEAK POWER OUTPUT (mW)	PEAK POWER OUTPUT (dBm)	PEAK POWER LIMIT (dBm)	PASS/FAIL
1	2412	60.256	17.80	30	PASS
2	2417	85.114	19.30	30	PASS
6	2437	107.152	20.30	30	PASS
10	2457	77.625	18.90	30	PASS
11	2462	58.884	17.70	30	PASS

Note: Channel 2 and 10 required by manufacture.



4.5 POWER SPECTRAL DENSITY MEASUREMENT

4.5.1 LIMITS OF POWER SPECTRAL DENSITY MEASUREMENT

The Maximum of Power Spectral Density Measurement is 8dBm.

4.5.2 TEST INSTRUMENTS

Description & Manufacturer	Model No.	Serial No.	Calibrated Until
R&S SPECTRUM ANALYZER	FSP40	100037	Aug. 15, 2007

NOTE:

- 1.The measurement uncertainty is less than +/- 2.6dB, which is calculated as per the NAMAS document NIS81. This uncertainty represents an expanded uncertainty expressed at approximately the 95% confidence level using a coverage factor of k=2.
- 2.The calibration interval of the above test instruments is 12 months and the calibrations are traceable to NML/ROC and NIST/USA.

4.5.3 TEST PROCEDURE

The transmitter output was connected to the spectrum analyzer through an attenuator, the bandwidth of the fundamental frequency was measured with the spectrum analyzer using 3kHz RBW and 30kHz VBW, set sweep time = span/3kHz. The power spectral density was measured and recorded. The sweep time is allowed to be longer than span/3kHz for a full response of the mixer in the spectrum analyzer.

4.5.4 DEVIATION FROM TEST STANDARD

No deviation

4.5.5 TEST SETUP

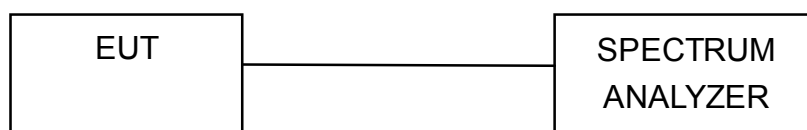

4.5.6 EUT OPERATING CONDITION

Same as Item 4.3.6



4.5.7 TEST RESULTS

802.11b DSSS modulation

MODULATION TYPE	CCK	TRANSFER RATE	1Mbps
INPUT POWER (SYSTEM)	120Vac, 60Hz	ENVIRONMENTAL CONDITIONS	18deg. C, 62%RH, 972hPa
TESTED BY	Wen Yu		

CHANNEL NUMBER	CHANNEL FREQUENCY (MHz)	RF POWER LEVEL IN 3 KHz BW (dBm)	MAXIMUM LIMIT (dBm)	PASS/FAIL
1	2412	-9.63	8	PASS
6	2437	-9.40	8	PASS
11	2462	-10.49	8	PASS

CH1

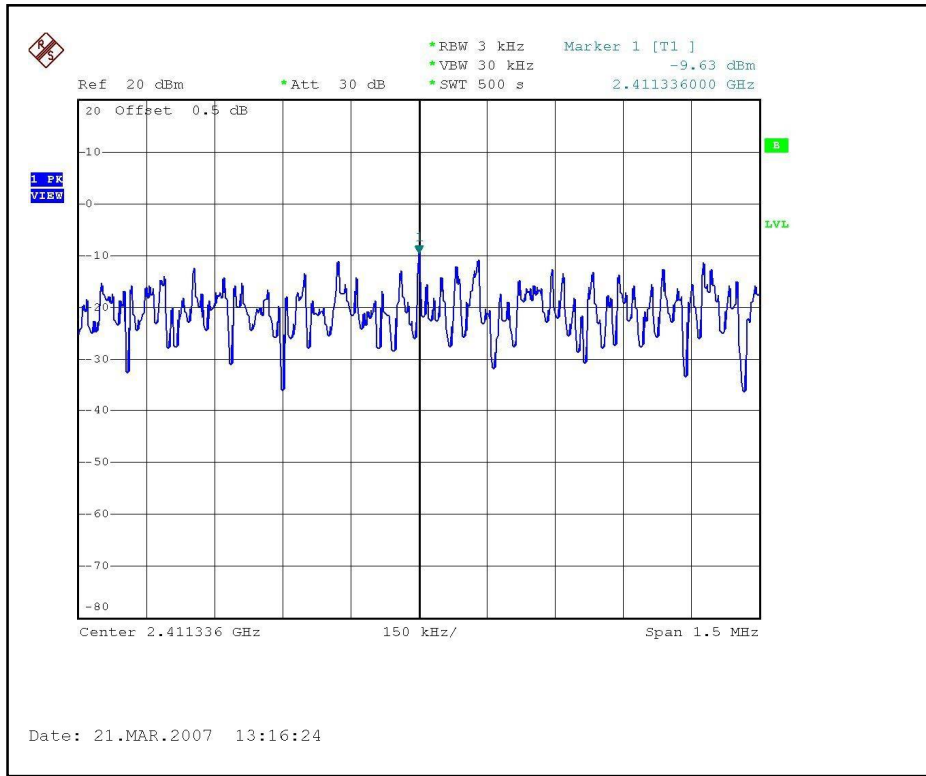

CH6

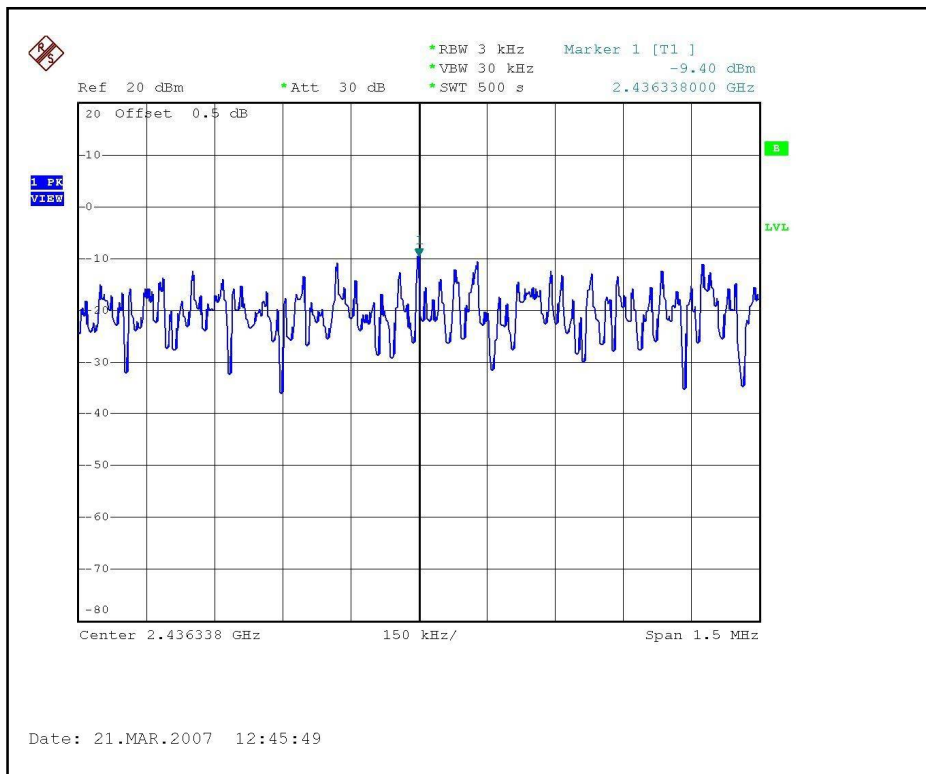

CH11

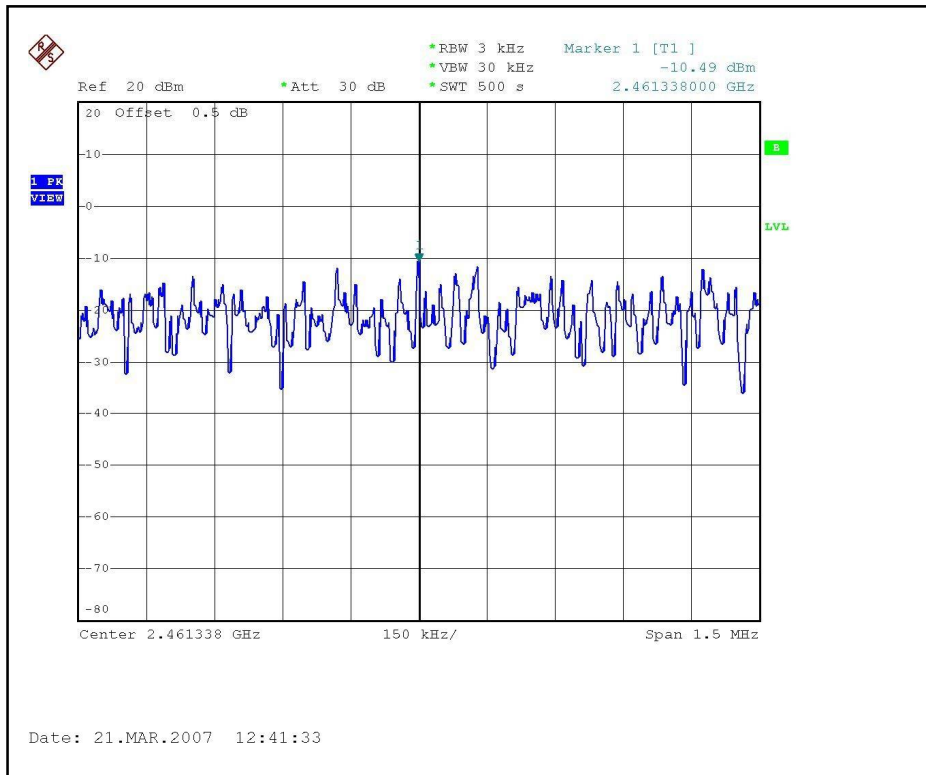



802.11g OFDM modulation

MODULATION TYPE	BPSK	TRANSFER RATE	6Mbps
INPUT POWER (SYSTEM)	120Vac, 60Hz	ENVIRONMENTAL CONDITIONS	18deg. C, 62%RH, 972hPa
TESTED BY	Wen Yu		

CHANNEL NUMBER	CHANNEL FREQUENCY (MHz)	RF POWER LEVEL IN 3 KHz BW (dBm)	MAXIMUM LIMIT (dBm)	PASS/FAIL
1	2412	-16.61	8	PASS
6	2437	-12.16	8	PASS
11	2462	-16.19	8	PASS

CH1

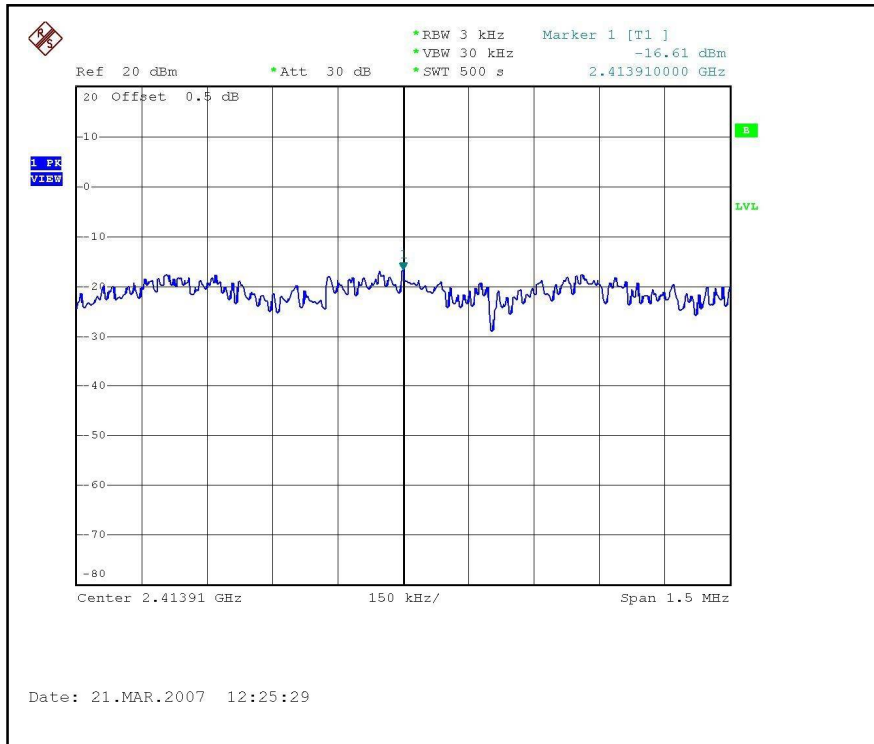

CH6

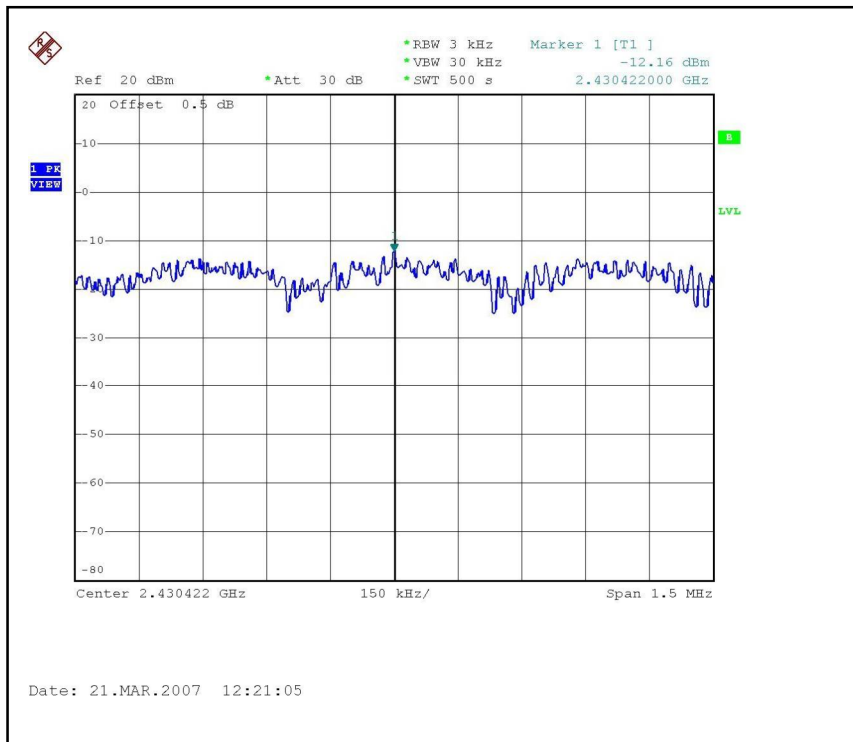

CH11

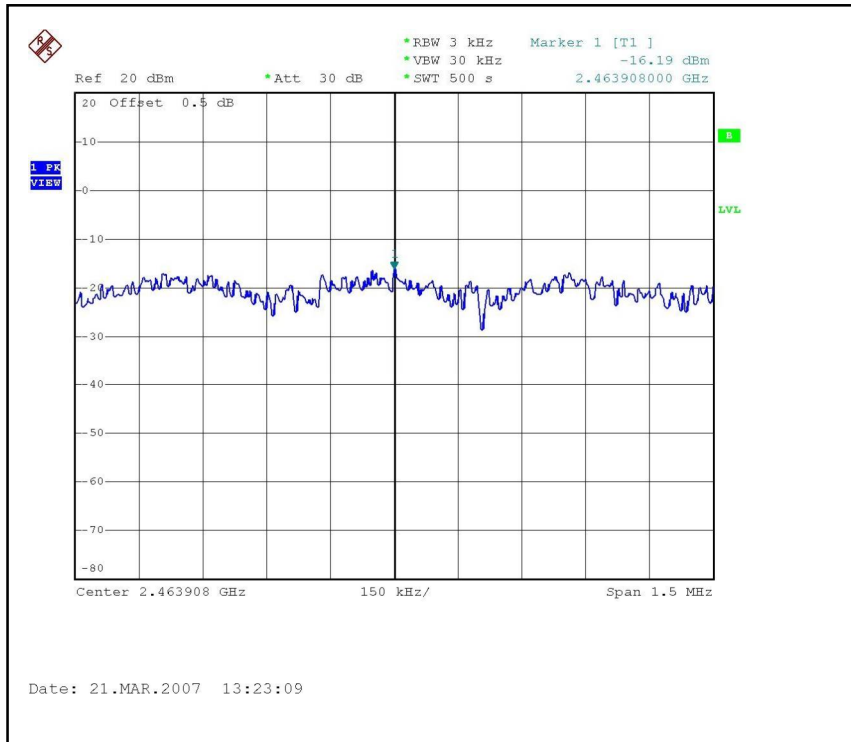



4.6 BAND EDGES MEASUREMENT

4.6.1 LIMITS OF BAND EDGES MEASUREMENT

Below -20dB of the highest emission level of operating band (in 1MHz Resolution Bandwidth).

4.6.2 TEST INSTRUMENTS

Description & Manufacturer	Model No.	Serial No.	Calibrated Until
R&S SPECTRUM ANALYZER	FSP40	100037	Aug. 15, 2007

NOTE:

- 1.The measurement uncertainty is less than +/- 2.6dB, which is calculated as per the NAMAS document NIS81. This uncertainty represents an expanded uncertainty expressed at approximately the 95% confidence level using a coverage factor of k=2.
- 2.The calibration interval of the above test instruments is 12 months and the calibrations are traceable to NML/ROC and NIST/USA.

4.6.3 TEST PROCEDURE

The transmitter output was connected to the spectrum analyzer via a low loss cable. Set both RBW and VBW of spectrum analyzer to 100kHz with suitable frequency span including 100 MHz bandwidth from band edge. The band edges was measured and recorded.

The spectrum plots (Peak RBW=VBW=1MHz ; Average RBW=1MHz, VBW=10Hz) are attached on the following pages.

4.6.4 EUT OPERATING CONDITION

Same as Item 4.3.5

4.6.5 TEST RESULTS

802.11b DSSS modulation

The spectrum plots are attached on the following page. D1 line indicates the highest level, D2 line indicates the 20dB offset below D1. It shows compliance with the requirement in part 15.247(C).

Note - The delta method is only used up to 2 MHz away from the restricted bandage, The radiated emissions which located in other restricted frequency band, the result, please refer to 4.2.

NOTE (Peak):

The band edge emission plot of DSSS technique on the following first page show 49.95dB delta between carrier maximum power and local maximum emission in restrict band (2.3900GHz). The emission of carrier strength list in the test result of channel 1 at the item 4.2 is 110.3dBuV/m, so the maximum field strength in restrict band is $110.3 - 49.95 = 60.35$ dBuV/m which is under 74 dBuV/m limit.

The band edge emission plot of DSSS technique on the following first page shows 50.48dB delta between carrier maximum power and local maximum emission in restrict band (2.4835GHz). The emission of carrier strength list in the test result of channel 11 at the item 4.2 is 109.1dBuV/m, so the maximum field strength in restrict band is $109.1 - 50.48 = 58.62$ dBuV/m which is under 74 dBuV/m limit.

NOTE (Average):

The band edge emission plot of DSSS technique on the following second page shows 54.99dB delta between carrier maximum power and local maximum emission in restrict band (2.3900GHz). The emission of carrier strength list in the test result of channel 1 at the item 4.2 is 105.7dBuV/m, so the maximum field strength in restrict band is $105.7 - 54.99 = 50.71$ dBuV/m which is under 54 dBuV/m limit.

The band edge emission plot of DSSS technique on the following second page shows 55.97dB delta between carrier maximum power and local maximum emission in restrict band (2.4835GHz). The emission of carrier strength list in the test result of channel 11 at the item 4.2 is 104.7dBuV/m, so the maximum field strength in restrict band is $104.7 - 55.97 = 48.73$ dBuV/m which is under 54 dBuV/m limit.

CH1

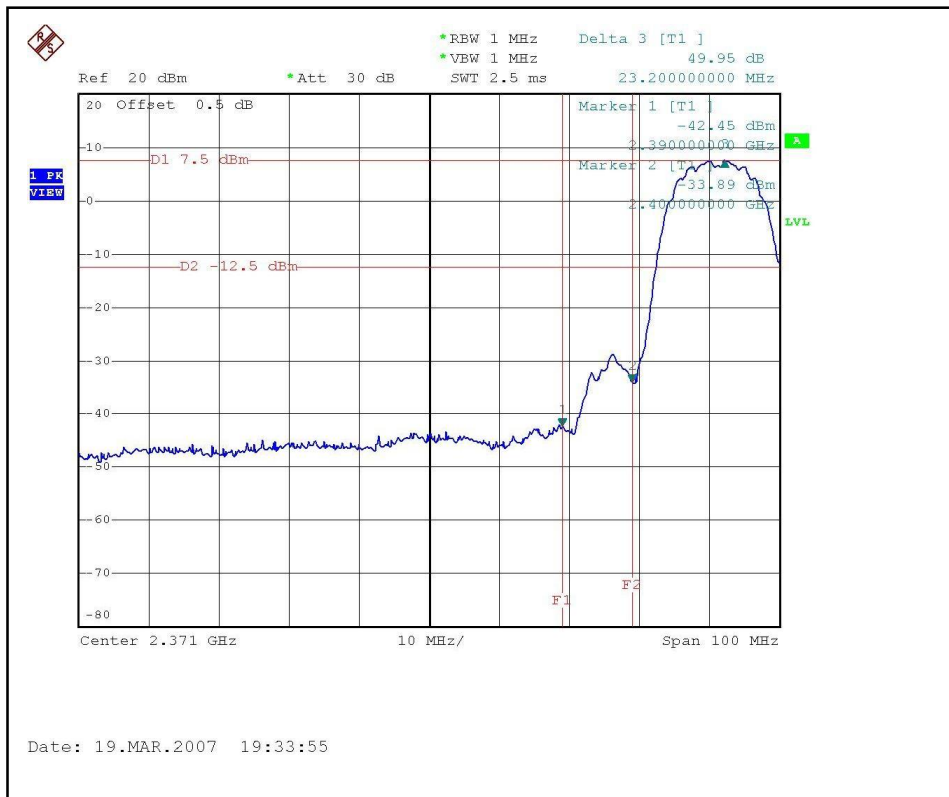

CH11

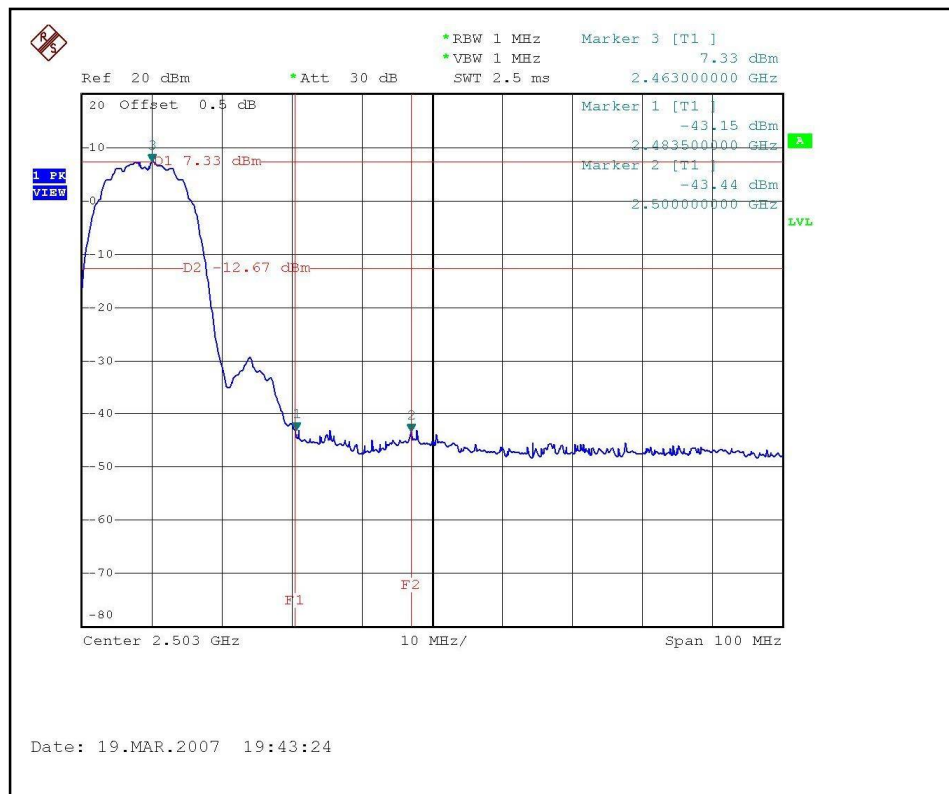

CH1

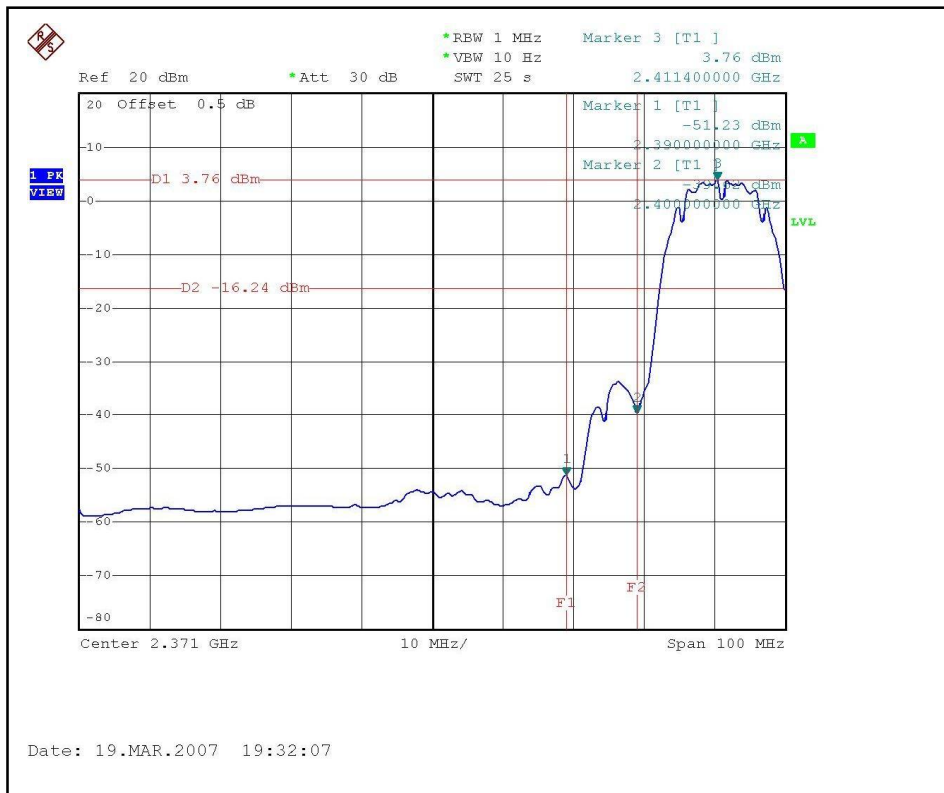

CH11

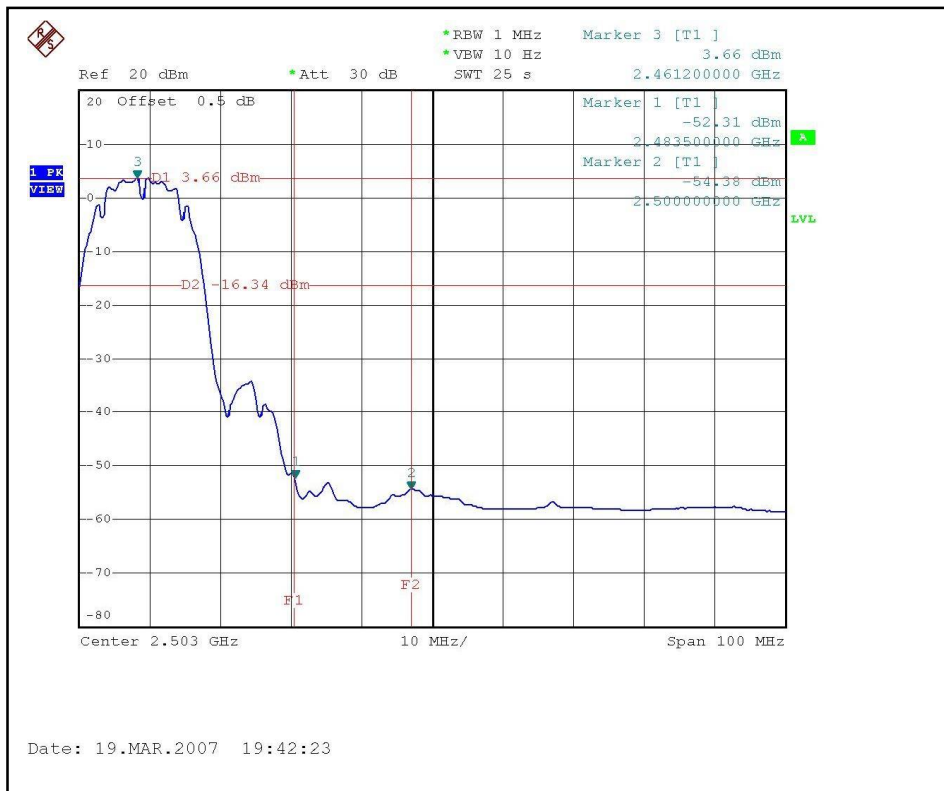

802.11b 10th conducted Harmonic

CH1

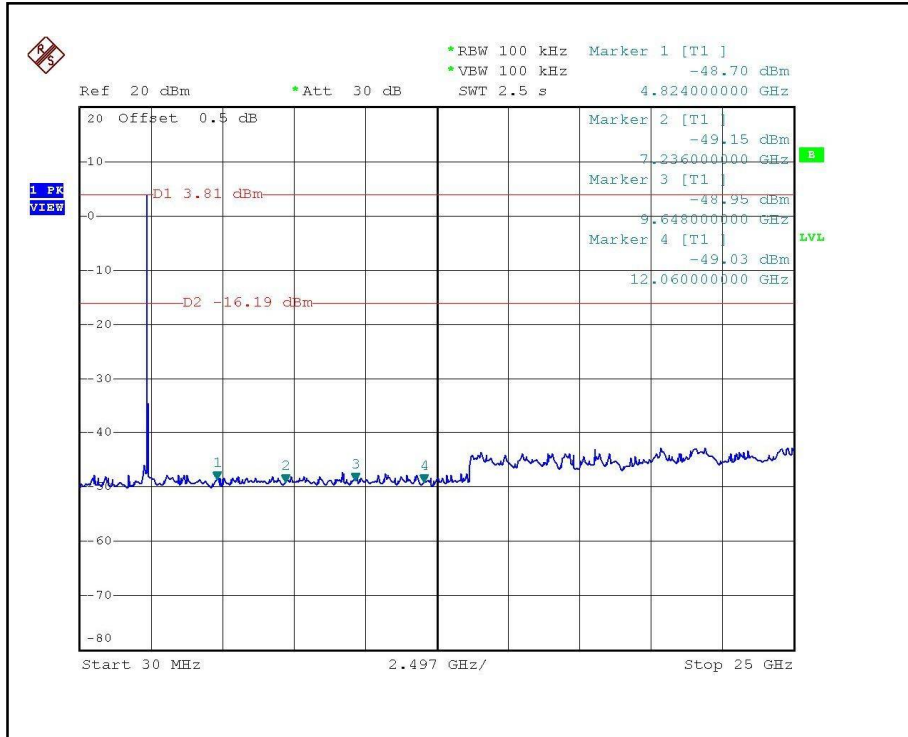

CH11

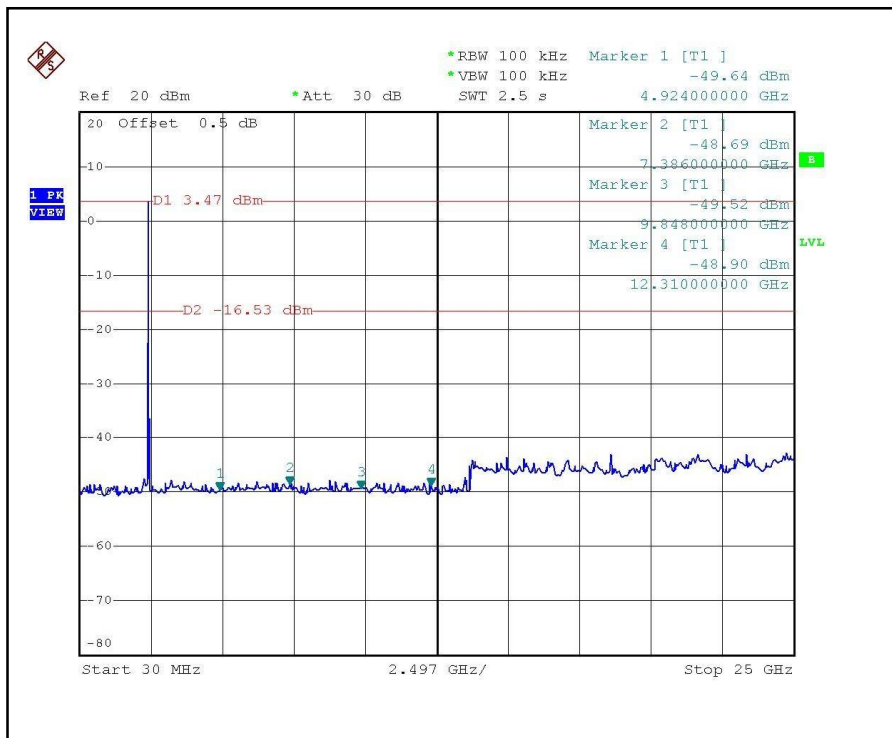

802.11g OFDM modulation

The spectrum plots are attached on the following page. D1 line indicates the highest level, D2 line indicates the 20dB offset below D1. It shows compliance with the requirement in part 15.247(C).

Note - The delta method is only used up to 2 MHz away from the restricted bandage, The radiated emissions which located in other restricted frequency band, the result, please refer to 4.2.

NOTE (Peak):

The band edge emission plot of OFDM technique on the following first page show 37.54dB delta between carrier maximum power and local maximum emission in restrict band (2.3900GHz). The emission of carrier strength list in the test result of channel 1 at the item 4.2 is 109.1dBuV/m, so the maximum field strength in restrict band is $109.1-37.54=71.56$ dBuV/m which is under 74 dBuV/m limit.

The band edge emission plot of OFDM technique on the following first page shows 35.97dB delta between carrier maximum power and local maximum emission in restrict band (2.4835GHz). The emission of carrier strength list in the test result of channel 11 at the item 4.2 is 108.50dBuV/m, so the maximum field strength in restrict band is $108.50-35.97=72.53$ dBuV/m which is under 74 dBuV/m limit.

NOTE (Average):

The band edge emission plot of OFDM technique on the following second page shows 46.93dB delta between carrier maximum power and local maximum emission in restrict band (2.3900GHz). The emission of carrier strength list in the test result of channel 1 at the item 4.2 is 99.8dBuV/m, so the maximum field strength in restrict band is $99.8-46.93=52.87$ dBuV/m which is under 54 dBuV/m limit.

The band edge emission plot of OFDM technique on the following second page shows 46.43dB delta between carrier maximum power and local maximum emission in restrict band (2.4835GHz). The emission of carrier strength list in the test result of channel 11 at the item 4.2 is 99.0dBuV/m, so the maximum field strength in restrict band is $99.0-46.43=52.57$ dBuV/m which is under 54 dBuV/m limit.

CH1

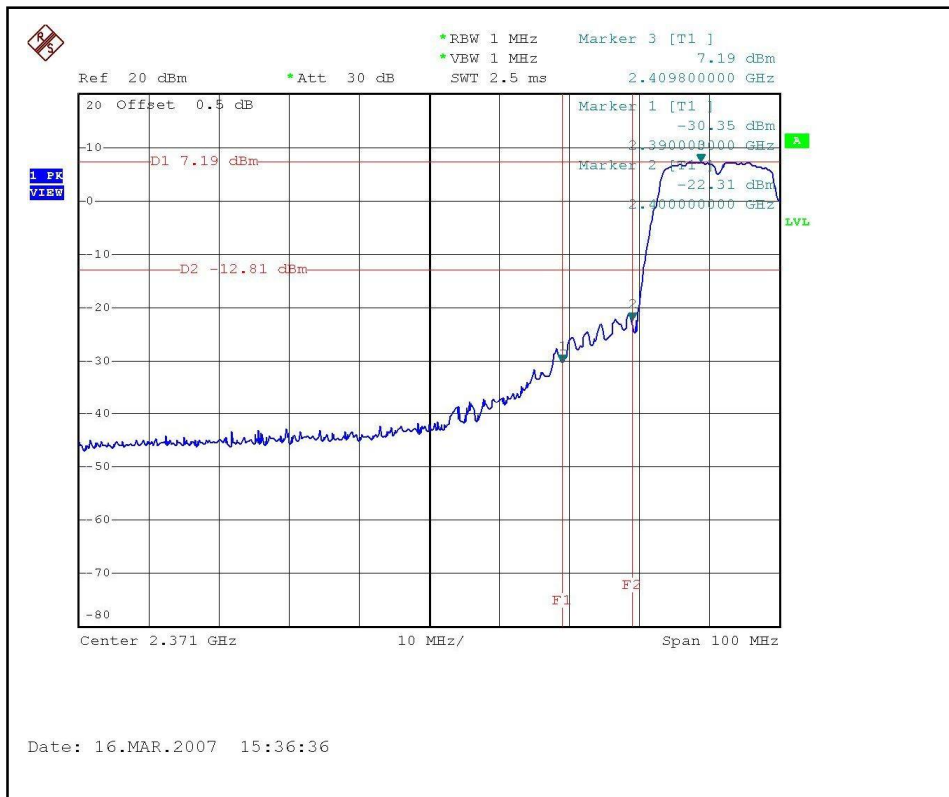

CH11

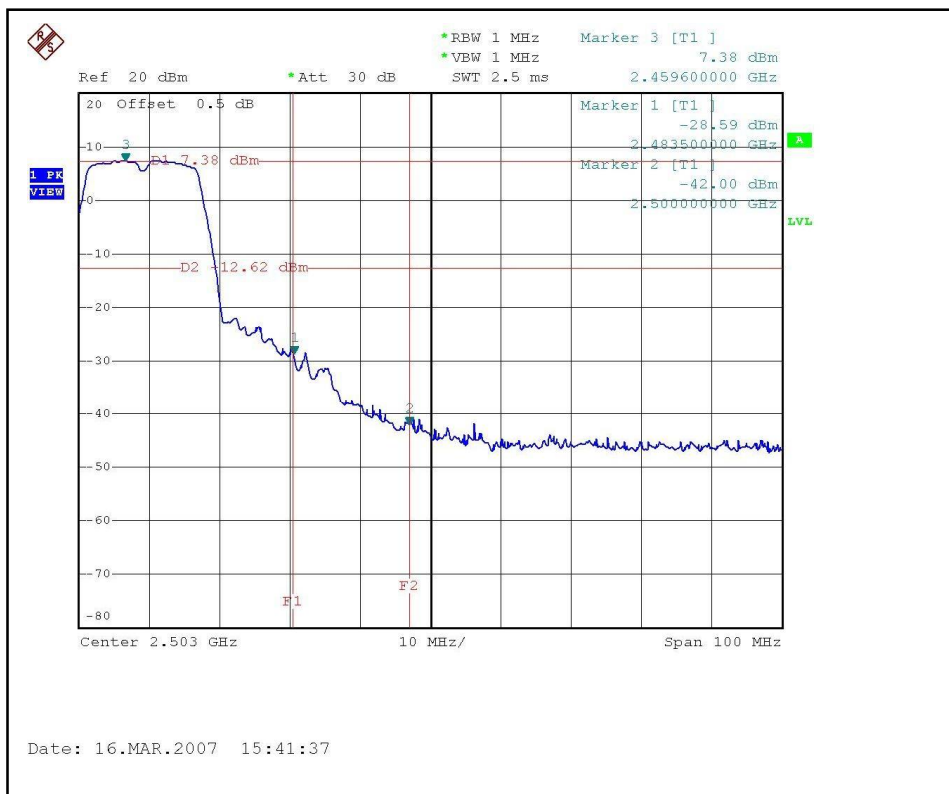

CH1

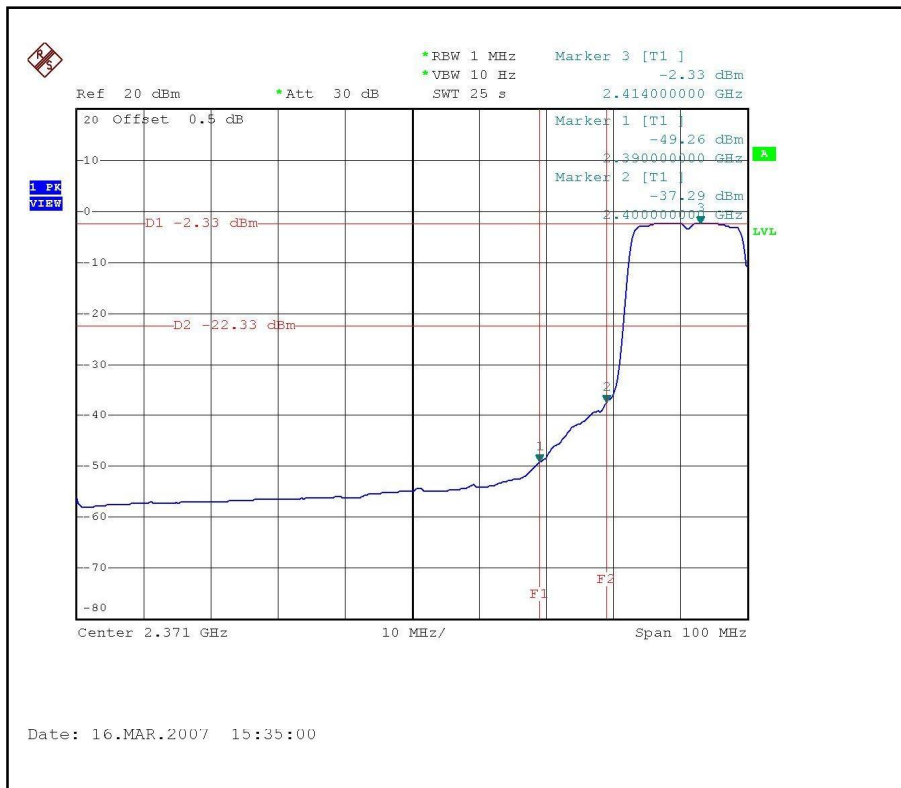

CH11

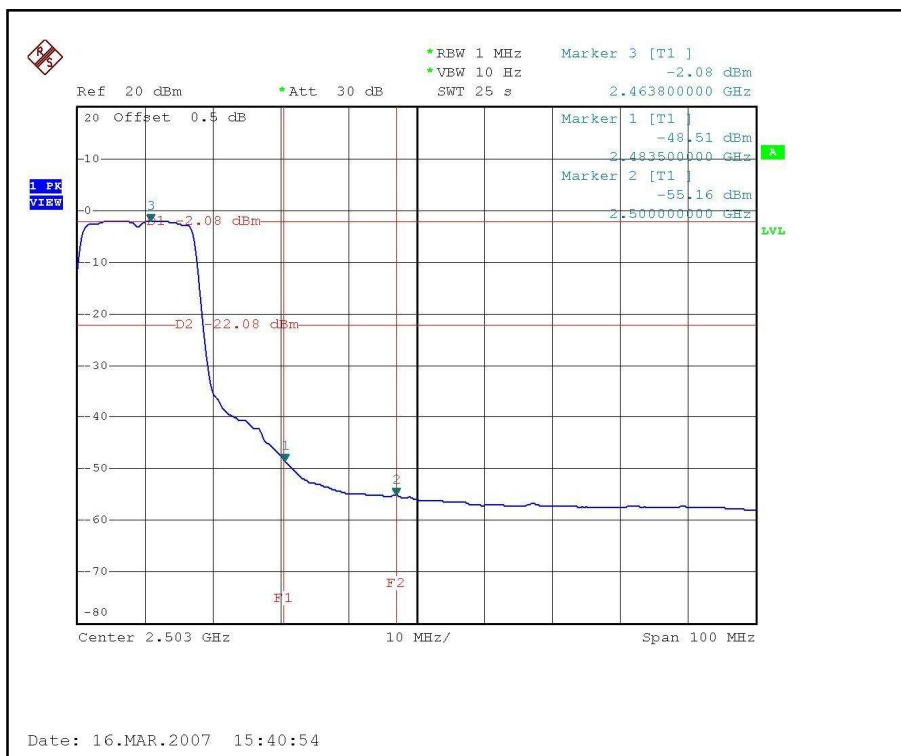

The spectrum plots are attached on the following page. D1 line indicates the highest level, D2 line indicates the 20dB offset below D1. It shows compliance with the requirement in part 15.247(C).

Note - The delta method is only used up to 2 MHz away from the restricted bandage, The radiated emissions which located in other restricted frequency band, the result, please refer to 4.2.

NOTE (Peak):

The band edge emission plot of OFDM technique on the following first page show 39.6dB delta between carrier maximum power and local maximum emission in restrict band (2.3900GHz). The emission of carrier strength list in the test result of channel 2 at the item 4.2 is 111.6dBuV/m, so the maximum field strength in restrict band is $111.6-39.6=72.0$ dBuV/m which is under 74 dBuV/m limit.

The band edge emission plot of OFDM technique on the following first page shows 36.78dB delta between carrier maximum power and local maximum emission in restrict band (2.4835GHz). The emission of carrier strength list in the test result of channel 10 at the item 4.2 is 109.8dBuV/m, so the maximum field strength in restrict band is $109.8-36.78=73.02$ dBuV/m which is under 74 dBuV/m limit.

NOTE (Average):

The band edge emission plot of OFDM technique on the following second page shows 48.54dB delta between carrier maximum power and local maximum emission in restrict band (2.3900GHz). The emission of carrier strength list in the test result of channel 2 at the item 4.2 is 102.2dBuV/m, so the maximum field strength in restrict band is $102.2-48.54=53.66$ dBuV/m which is under 54 dBuV/m limit.

The band edge emission plot of OFDM technique on the following second page shows 47.49dB delta between carrier maximum power and local maximum emission in restrict band (2.4835GHz). The emission of carrier strength list in the test result of channel 10 at the item 4.2 is 100.40dBuV/m, so the maximum field strength in restrict band is $100.40-47.49=52.91$ dBuV/m which is under 54 dBuV/m limit.

Note: Channel 2 and 10 required by manufacture.

CH2

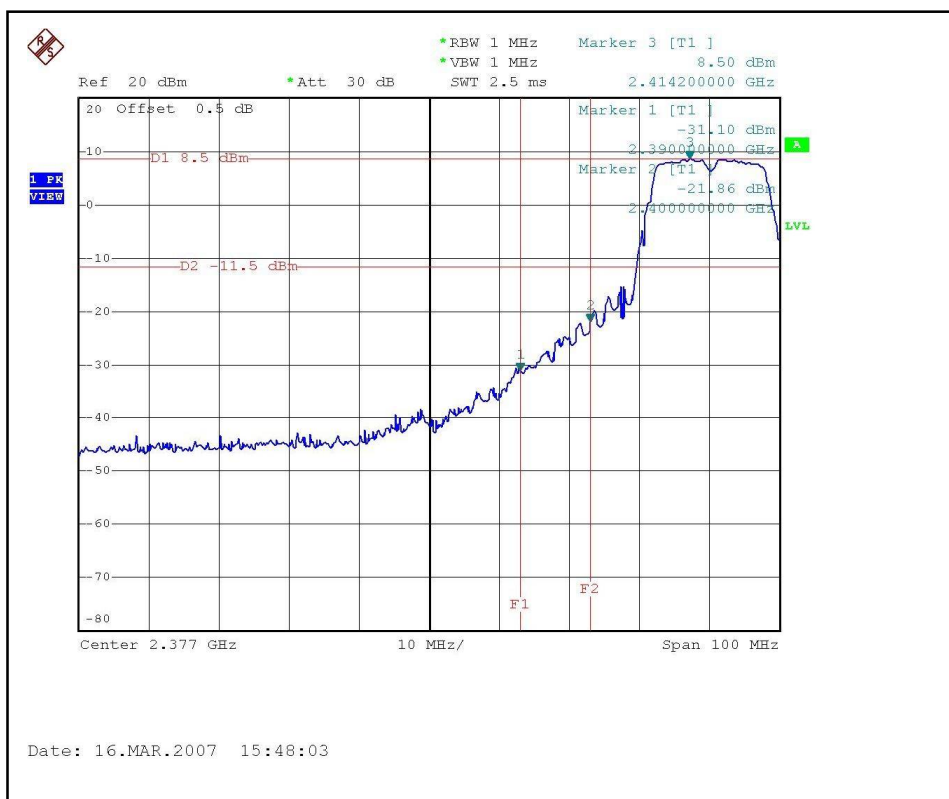

CH10

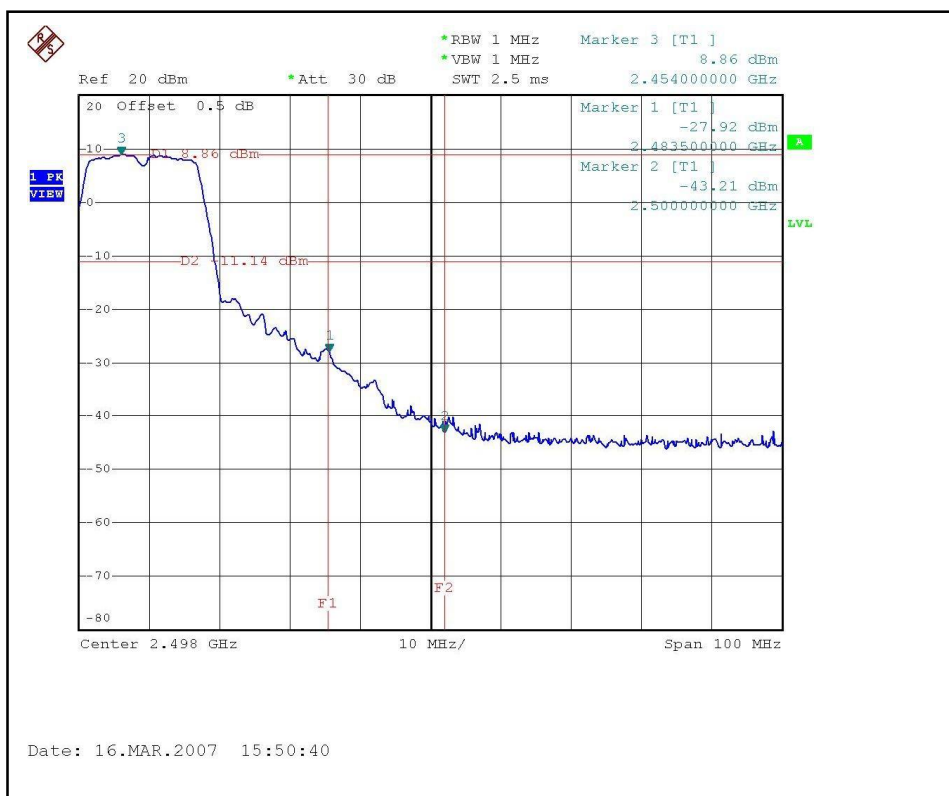

CH2

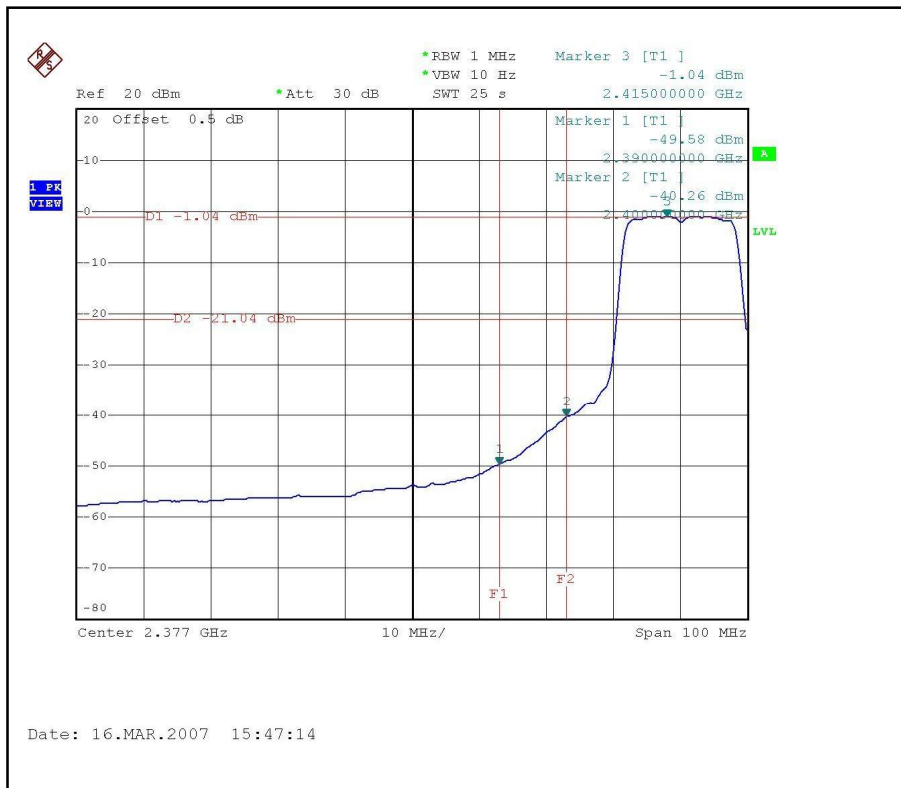

CH10

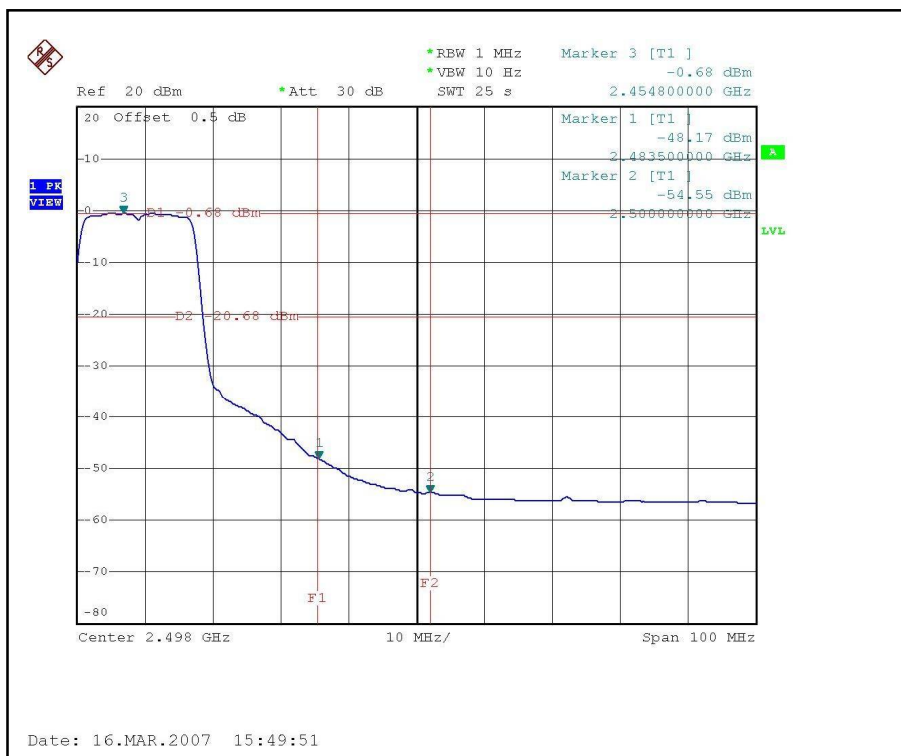

802.11g 10th conducted Harmonic

CH1

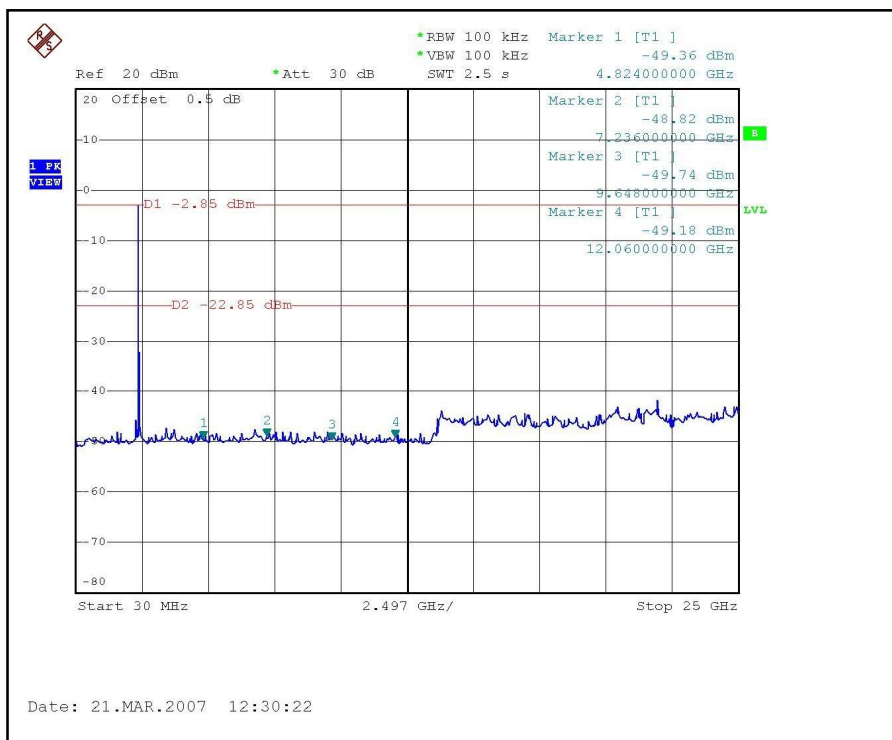

CH11

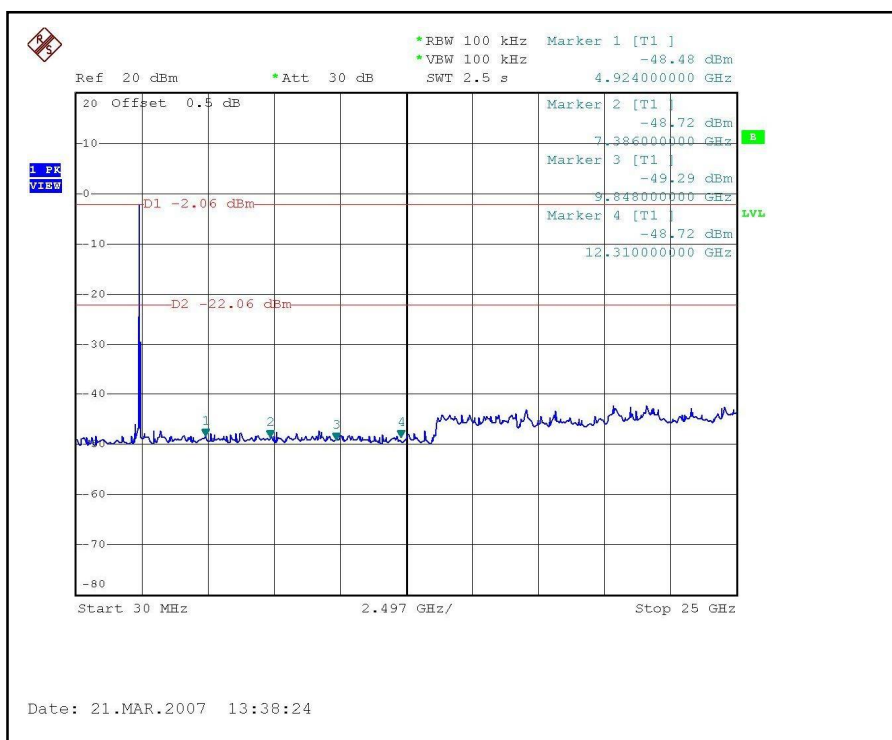

4.7 ANTENNA REQUIREMENT

4.7.1 STANDARD APPLICABLE

For intentional device, according to FCC 47 CFR Section 15.203, an intentional radiator shall be designed to ensure that no antenna other than that furnished by the responsible party shall be used with the device. And according to FCC 47 CFR Section 15.247 (b), if transmitting antennas of directional gain greater than 6dBi are used, the power shall be reduced by the amount in dB that the directional gain of the antenna exceeds 6dBi.

4.7.2 ANTENNA CONNECTED CONSTRUCTION

The antenna used in this product is one dipole antenna with RP-SMA MALE connector. The maximum Gain of the antenna is 2.5dBi.