

FCC Test Report

Report No.: RF200326C09-2

FCC ID: H8NTN230A2

Test Model: TN230A2

Received Date: Mar. 26, 2020

Test Date: Apr. 07 ~ Apr. 18, 2020

Issued Date: May 08, 2020

Applicant: ASKEY COMPUTER CORP.

Address: 10F, NO.119, JIANKANG RD., ZHONGHE DIST., NEW TAIPEI CITY 23585,
TAIWAN, R.O.C.

Issued By: Bureau Veritas Consumer Products Services (H.K.) Ltd., Taoyuan Branch
Lin Kou Laboratories

Lab Address: No. 47-2, 14th Ling, Chia Pau Vil., Lin Kou Dist., New Taipei City, Taiwan

Test Location: No.19, Hwa Ya 2nd Rd., Wen Hwa Vil., Kwei Shan Dist., Taoyuan City
33383, Taiwan

**FCC Registration /
Designation Number:** 788550 / TW0003



This report is for your exclusive use. Any copying or replication of this report to or for any other person or entity, or use of our name or trademark, is permitted only with our prior written permission. This report sets forth our findings solely with respect to the test samples identified herein. The results set forth in this report are not indicative or representative of the quality or characteristics of the lot from which a test sample was taken or any similar or identical product unless specifically and expressly noted. Our report includes all of the tests requested by you and the results thereof based upon the information that you provided to us. You have 60 days from date of issuance of this report to notify us of any material error or omission caused by our negligence, provided, however, that such notice shall be in writing and shall specifically address the issue you wish to raise. A failure to raise such issue within the prescribed time shall constitute your unqualified acceptance of the completeness of this report, the tests conducted and the correctness of the report contents. Unless specific mention, the uncertainty of measurement has been explicitly taken into account to declare the compliance or non-compliance to the specification. The report must not be used by the client to claim product certification, approval, or endorsement by TAF or any government agencies.

Table of Contents

| | |
|---|-----------|
| Release Control Record | 4 |
| 1 Certificate of Conformity | 5 |
| 2 Summary of Test Results | 6 |
| 2.1 Measurement Uncertainty | 6 |
| 2.2 Modification Record | 6 |
| 3 General Information | 7 |
| 3.1 General Description of EUT | 7 |
| 3.2 Description of Test Modes | 8 |
| 3.2.1 Test Mode Applicability and Tested Channel Detail | 9 |
| 3.3 Duty Cycle of Test Signal | 11 |
| 3.4 Description of Support Units | 12 |
| 3.4.1 Configuration of System under Test | 12 |
| 3.5 General Description of Applied Standards and References | 13 |
| 4 Test Types and Results | 14 |
| 4.1 Radiated Emission and Bandedge Measurement | 14 |
| 4.1.1 Limits of Radiated Emission and Bandedge Measurement | 14 |
| 4.1.2 Test Instruments | 15 |
| 4.1.3 Test Procedures | 16 |
| 4.1.4 Deviation from Test Standard | 17 |
| 4.1.5 Test Set Up | 17 |
| 4.1.6 EUT Operating Conditions | 18 |
| 4.1.7 Test Results | 19 |
| 4.2 Conducted Emission Measurement | 32 |
| 4.2.1 Limits of Conducted Emission Measurement | 32 |
| 4.2.2 Test Instruments | 32 |
| 4.2.3 Test Procedures | 32 |
| 4.2.4 Deviation from Test Standard | 33 |
| 4.2.5 Test Setup | 33 |
| 4.2.6 EUT Operating Conditions | 33 |
| 4.2.7 Test Results | 34 |
| 4.3 6 dB Bandwidth Measurement | 38 |
| 4.3.1 Limits of 6 dB Bandwidth Measurement | 38 |
| 4.3.2 Test Setup | 38 |
| 4.3.3 Test Instruments | 38 |
| 4.3.4 Test Procedure | 38 |
| 4.3.5 Deviation from Test Standard | 38 |
| 4.3.6 EUT Operating Conditions | 38 |
| 4.3.7 Test Results | 39 |
| 4.4 Occupied Bandwidth Measurement | 41 |
| 4.4.1 Test Setup | 41 |
| 4.4.2 Test Instruments | 41 |
| 4.4.3 Test Procedure | 41 |
| 4.4.4 Deviation from Test Standard | 41 |
| 4.4.5 EUT Operating Conditions | 41 |
| 4.4.6 Test Results | 42 |
| 4.5 Conducted Output Power Measurement | 44 |
| 4.5.1 Limits of Conducted Output Power Measurement | 44 |
| 4.5.2 Test Setup | 44 |
| 4.5.3 Test Instruments | 44 |
| 4.5.4 Test Procedures | 44 |
| 4.5.5 Deviation from Test Standard | 44 |
| 4.5.6 EUT Operating Conditions | 44 |
| 4.5.7 Test Results | 45 |

| | | |
|----------|---|-----------|
| 4.6 | Power Spectral Density Measurement | 47 |
| 4.6.1 | Limits of Power Spectral Density Measurement..... | 47 |
| 4.6.2 | Test Setup..... | 47 |
| 4.6.3 | Test Instruments | 47 |
| 4.6.4 | Test Procedure | 47 |
| 4.6.5 | Deviation from Test Standard | 47 |
| 4.6.6 | EUT Operating Condition | 47 |
| 4.6.7 | Test Results | 48 |
| 4.7 | Conducted Out of Band Emission Measurement | 50 |
| 4.7.1 | Limits of Conducted Out of Band Emission Measurement..... | 50 |
| 4.7.2 | Test Setup..... | 50 |
| 4.7.3 | Test Instruments | 50 |
| 4.7.4 | Test Procedure | 50 |
| 4.7.5 | Deviation from Test Standard | 50 |
| 4.7.6 | EUT Operating Condition | 50 |
| 4.7.7 | Test Results | 51 |
| 5 | Pictures of Test Arrangements..... | 54 |
| | Annex A – Band Edge Measurement | 55 |
| | Appendix – Information of the Testing Laboratories | 58 |

Release Control Record

| Issue No. | Description | Date Issued |
|---------------|------------------|--------------|
| RF200326C09-2 | Original Release | May 08, 2020 |

1 Certificate of Conformity

Product: Smart watch

Brand: TURBONET

Test Model: TN230A2

Sample Status: Engineering Sample

Applicant: ASKEY COMPUTER CORP.

Test Date: Apr. 07 ~ Apr. 18, 2020

Standards: 47 CFR FCC Part 15, Subpart C (Section 15.247)
ANSI C63.10:2013

The above equipment has been tested by **Bureau Veritas Consumer Products Services (H.K.) Ltd., Taoyuan Branch**, and found compliance with the requirement of the above standards. The test record, data evaluation & Equipment Under Test (EUT) configurations represented herein are true and accurate accounts of the measurements of the sample's RF characteristics under the conditions specified in this report.

Prepared by : Gina Liu, **Date:** May 08, 2020
Gina Liu / Specialist

Approved by : Dylan Chiou, **Date:** May 08, 2020
Dylan Chiou / Senior Project Engineer

2 Summary of Test Results

| 47 CFR FCC Part 15, Subpart C (Section 15.247) | | | |
|--|--|--------|---|
| FCC Clause | Test Item | Result | Remarks |
| 15.207 | AC Power Conducted Emission | Pass | Meet the requirement of limit. Minimum passing margin is -22.31 dB at 0.56016 MHz. |
| 15.205 / 15.209 / 15.247(d) | Radiated Emissions and Band Edge Measurement | Pass | Meet the requirement of limit. Minimum passing margin is -8.2 dB at 52.31 MHz. |
| 15.247(d) | Antenna Port Emission | Pass | Meet the requirement of limit. |
| 15.247(a)(2) | 6 dB Bandwidth | Pass | Meet the requirement of limit. |
| --- | Occupied Bandwidth Measurement | Pass | Reference only |
| 15.247(b) | Conducted power | Pass | Meet the requirement of limit. |
| 15.247(e) | Power Spectral Density | Pass | Meet the requirement of limit. |
| 15.203 | Antenna Requirement | Pass | No antenna connector is used. |

Note:

- For 2.4G band compliance with rule 15.247(d) of the band-edge items, the test plots were recorded in Annex A. Test Procedures refer to report 4.1.3.
- Determining compliance based on the results of the compliance measurement, not taking into account measurement instrumentation uncertainty.

2.1 Measurement Uncertainty

Where relevant, the following measurement uncertainty levels have been estimated for tests performed on the EUT as specified in CISPR 16-4-2:

| Measurement | Frequency | Expanded Uncertainty (k=2) (±) |
|------------------------------------|--------------------|--------------------------------|
| Conducted Emissions at mains ports | 150 kHz ~ 30 MHz | 2.79 dB |
| Radiated Emissions up to 1 GHz | 9 kHz ~ 30 MHz | 3.04 dB |
| | 30 MHz ~ 200 MHz | 2.93 dB |
| | 200 MHz ~ 1000 MHz | 2.95 dB |
| Radiated Emissions above 1 GHz | 1 GHz ~ 18 GHz | 2.26 dB |
| | 18 GHz ~ 40 GHz | 1.94 dB |

2.2 Modification Record

There were no modifications required for compliance.

3 General Information

3.1 General Description of EUT

| | |
|--|---|
| Product | Smart watch |
| Brand | TURBONET |
| Test Model | TN230A2 |
| Status of EUT | Engineering Sample |
| Power Supply Rating | 5.35 Vdc (adapter) 5.0 Vdc (host equipment) 3.7 Vdc (Li-ion battery) |
| Modulation Type | CCK, DQPSK, DBPSK for DSSS 64QAM, 16QAM, QPSK, BPSK for OFDM |
| Modulation Technology | DSSS, OFDM |
| Transfer Rate | 802.11b: 11.0 / 5.5 / 2.0 / 1.0 Mbps 802.11g: 54.0 / 48.0 / 36.0 / 24.0 / 18.0 / 12.0 / 9.0 / 6.0 Mbps 802.11n: up to 72.2 Mbps |
| Operating Frequency | 2412 ~ 2462 MHz |
| Number of Channel | 11 for 802.11b, 802.11g, 802.11n (HT20) |
| Output Power (Measured Max. Peak) | 138.357 mW |
| Antenna Type | PIFA |
| Antenna Connector | N/A |
| Accessory Device | Refer to Note as below |
| Data Cable Supplied | 0.95m shielded USB cable without core |

Note:

1. There're 3 configurations for the EUT listed as below.

| Configuration | Brand | Model | Difference |
|---------------|----------|---------|--|
| 1 | TURBONET | TN230A2 | All function |
| 2 | | | Without heartbeat detection and camera function |
| 3 | | | Without heartbeat detection but with camera function |

*The Configuration 1 was chosen for final test.

2. The EUT incorporates a SISO function. Physically, the EUT provides one completed transmitter and one receiver.

| Modulation Mode | Tx Function |
|-----------------|-------------|
| 802.11b | 1TX |
| 802.11g | 1TX |
| 802.11n (HT20) | 1TX |

3. The antenna information is listed.

| Ant. Type | Frequency (MHz) | | | | | | | | | | |
|-----------|-----------------|----------|----------|----------|----------|----------|----------|----------|----------|----------|----------|
| | 2402 | 2442 | 2484 | 5180 | 5220 | 5320 | 5420 | 5520 | 5620 | 5720 | 5825 |
| PIFA | 2.50 dBi | 2.30 dBi | 2.20 dBi | 0.91 dBi | 0.85 dBi | 0.90 dBi | 1.54 dBi | 2.23 dBi | 2.12 dBi | 2.20 dBi | 2.00 dBi |

4. The above Antenna information is declared by manufacturer and for more detailed features description, please refer to the manufacturer's specifications, the laboratory shall not be held responsible.

5. The following accessories were for the End-product.

| Product | Brand | Model | Description |
|-----------|-------------------------|----------------|---|
| Adapter | Sunny ELECTRONICS CORP. | SYS1561-1105-1 | I/P: 100-240 Vac, 50-60 Hz, 1.0 A MAX O/P: 5.35 Vdc, 2 A |
| Battery | ETI | BP19-002750 | 3.7 Vdc, 800 mAh |
| USB Cable | N/A | N/A | 0.95m shielded USB cable without core |

6. The above EUT information is declared by manufacturer and for more detailed features description, please refers to the manufacturer's specifications or user's manual.

3.2 Description of Test Modes

11 channels are provided for 802.11b, 802.11g and 802.11n (HT20):

| Channel | Frequency (MHz) | Channel | Frequency (MHz) |
|---------|-----------------|---------|-----------------|
| 1 | 2412 | 7 | 2442 |
| 2 | 2417 | 8 | 2447 |
| 3 | 2422 | 9 | 2452 |
| 4 | 2427 | 10 | 2457 |
| 5 | 2432 | 11 | 2462 |
| 6 | 2437 | | |

3.2.1 Test Mode Applicability and Tested Channel Detail

| EUT Configure Mode | Applicable To | | | | Description |
|--------------------|---------------|-------|-----|------|-------------------|
| | RE \geq 1G | RE<1G | PLC | APCM | |
| A | √ | √ | √ | √ | EUT with Adapter |
| B | - | √ | √ | - | EUT with Notebook |

Where **RE \geq 1G**: Radiated Emission above 1 GHz **RE<1G**: Radiated Emission below 1 GHz
PLC: Power Line Conducted Emission **APCM**: Antenna Port Conducted Measurement

NOTE: The EUT had been pre-tested on the positioned of each 3 axis. The worst case was found when positioned on **Y-plane**.

NOTE: "-" means no effect.

NOTE: For radiated emission (below 1GHz) and power line conducted emission test items, the worst maximum power was selected.

Radiated Emission Test (Above 1 GHz):

- Pre-Scan has been conducted to determine the worst-case mode from all possible combinations between available modulations, data rates and antenna ports (if EUT with antenna diversity architecture).
- Following channel(s) was (were) selected for the final test as listed below.

| EUT Configure Mode | Mode | Available Channel | Tested Channel | Modulation Technology | Modulation Type | Data Rate (Mbps) |
|--------------------|----------------|-------------------|----------------|-----------------------|-----------------|------------------|
| A | 802.11b | 1 to 11 | 1, 6, 11 | DSSS | DBPSK | 1.0 |
| | 802.11g | 1 to 11 | 1, 6, 11 | OFDM | BPSK | 6.0 |
| | 802.11n (HT20) | 1 to 11 | 1, 6, 11 | OFDM | BPSK | 6.5 |

Radiated Emission Test (Below 1 GHz):

- Pre-Scan has been conducted to determine the worst-case mode from all possible combinations between available modulations, data rates and antenna ports (if EUT with antenna diversity architecture).
- Following channel(s) was (were) selected for the final test as listed below.

| EUT Configure Mode | Mode | Available Channel | Tested Channel | Modulation Technology | Modulation Type | Data Rate (Mbps) |
|--------------------|----------------|-------------------|----------------|-----------------------|-----------------|------------------|
| A, B | 802.11n (HT20) | 1 to 11 | 11 | OFDM | BPSK | 6.5 |

Power Line Conducted Emission Test:

- Pre-Scan has been conducted to determine the worst-case mode from all possible combinations between available modulations, data rates and antenna ports (if EUT with antenna diversity architecture).
- Following channel(s) was (were) selected for the final test as listed below.

| EUT Configure Mode | Mode | Available Channel | Tested Channel | Modulation Technology | Modulation Type | Data Rate (Mbps) |
|--------------------|----------------|-------------------|----------------|-----------------------|-----------------|------------------|
| A, B | 802.11n (HT20) | 1 to 11 | 11 | OFDM | BPSK | 6.5 |

Bandedge Measurement:

- Pre-Scan has been conducted to determine the worst-case mode from all possible combinations between available modulations, data rates and antenna ports (if EUT with antenna diversity architecture).
- Following channel(s) was (were) selected for the final test as listed below.

| EUT Configure Mode | Mode | Available Channel | Tested Channel | Modulation Technology | Modulation Type | Data Rate (Mbps) |
|--------------------|----------------|-------------------|----------------|-----------------------|-----------------|------------------|
| A | 802.11b | 1 to 11 | 1, 11 | DSSS | DBPSK | 1.0 |
| | 802.11g | 1 to 11 | 1, 11 | OFDM | BPSK | 6.0 |
| | 802.11n (HT20) | 1 to 11 | 1, 11 | OFDM | BPSK | 6.5 |

Antenna Port Conducted Measurement:

- This item includes all test value of each mode, but only includes spectrum plot of worst value of each mode.
- Pre-Scan has been conducted to determine the worst-case mode from all possible combinations between available modulations, data rates and antenna ports (if EUT with antenna diversity architecture).
- Following channel(s) was (were) selected for the final test as listed below.

| EUT Configure Mode | Mode | Available Channel | Tested Channel | Modulation Technology | Modulation Type | Data Rate (Mbps) |
|--------------------|----------------|-------------------|----------------|-----------------------|-----------------|------------------|
| A | 802.11b | 1 to 11 | 1, 6, 11 | DSSS | DBPSK | 1.0 |
| | 802.11g | 1 to 11 | 1, 6, 11 | OFDM | BPSK | 6.0 |
| | 802.11n (HT20) | 1 to 11 | 1, 6, 11 | OFDM | BPSK | 6.5 |

Test Condition:

| Applicable To | Environmental Conditions | Input Power | Tested by |
|---------------|--------------------------|----------------|------------------|
| RE \geq 1G | 25 deg. C, 65 % RH | 120 Vac, 60 Hz | Han Wu |
| RE<1G | 25 deg. C, 65 % RH | 120 Vac, 60 Hz | Han Wu, Greg Lin |
| PLC | 25 deg. C, 65 % RH | 120 Vac, 60 Hz | Han Wu |
| APCM | 25 deg. C, 65 % RH | 3.7 Vdc | Ted Chang |

3.3 Duty Cycle of Test Signal

Duty cycle of test signal is < 98 %, duty factor shall be considered.

802.11b: Duty cycle = $8.22/8.43 = 0.975$, Duty factor = $10 * \log(1/0.975) = 0.11$

802.11g: Duty cycle = $1.367/1.564 = 0.874$, Duty factor = $10 * \log(1/0.874) = 0.58$

802.11n (HT20): Duty cycle = $1.274/1.494 = 0.853$, Duty factor = $10 * \log(1/0.853) = 0.69$



3.4 Description of Support Units

The EUT has been tested as an independent unit together with other necessary accessories or support units. The following support units or accessories were used to form a representative test configuration during the tests.

| ID | Product | Brand | Model No. | Serial No. | FCC ID | Remarks |
|----|----------|--------|-----------|------------|--------|-----------------|
| A. | Notebook | Lenovo | 80Q7 | PF0KUGU6 | N/A | Provided by Lab |

Note:

1. All power cords of the above support units are non-shielded (1.8m).
2. Item A acted as communication partner to transfer data.

| ID | Cable Descriptions | Qty. | Length (m) | Shielding (Yes/No) | Cores (Qty.) | Remarks |
|----|--------------------|------|------------|--------------------|--------------|----------------------|
| 1. | USB Cable | 1 | 0.95 | Y | 0 | Accessory of the EUT |

3.4.1 Configuration of System under Test

Mode A

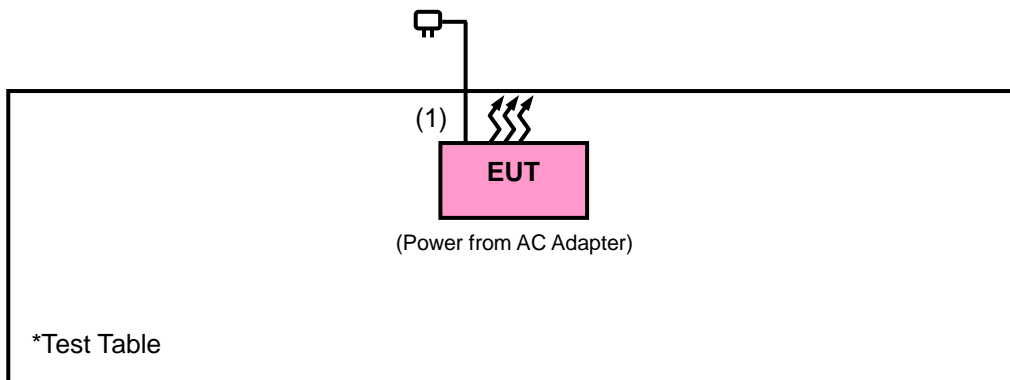

Mode B

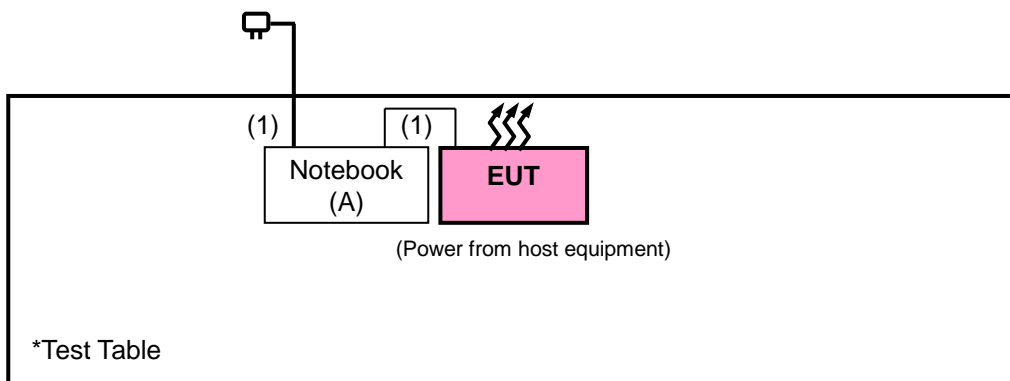

3.5 General Description of Applied Standards and References

The EUT is a RF Product. According to the specifications of the manufacturer, it must comply with the requirements of the following standards and references:

Test Standard:

FCC Part 15, Subpart C (15.247)

ANSI C63.10-2013

All test items have been performed and recorded as per the above standards.

References Test Guidance:

KDB 558074 D01 Meas Guidance v05r02

All test items have been performed as a reference to the above KDB test guidance.

4 Test Types and Results

4.1 Radiated Emission and Bandedge Measurement

4.1.1 Limits of Radiated Emission and Bandedge Measurement

Radiated emissions which fall in the restricted bands must comply with the radiated emission limits specified as below table. Other emissions shall be at least 20 dB below the highest level of the desired power:

| Frequencies (MHz) | Field Strength (microvolts/meter) | Measurement Distance (meters) |
|-------------------|-----------------------------------|-------------------------------|
| 0.009 ~ 0.490 | 2400/F (kHz) | 300 |
| 0.490 ~ 1.705 | 24000/F (kHz) | 30 |
| 1.705 ~ 30.0 | 30 | 30 |
| 30 ~ 88 | 100 | 3 |
| 88 ~ 216 | 150 | 3 |
| 216 ~ 960 | 200 | 3 |
| Above 960 | 500 | 3 |

NOTE:

1. The lower limit shall apply at the transition frequencies.
2. Emission level (dBuV/m) = 20 log Emission level (uV/m).
3. For frequencies above 1000 MHz, the field strength limits are based on average detector, however, the peak field strength of any emission shall not exceed the maximum permitted average limits, specified above by more than 20 dB under any condition of modulation.

4.1.2 Test Instruments

| Description & Manufacturer | Model No. | Serial No. | Date Of Calibration | Due Date Of Calibration |
|--|--|---|---------------------|-------------------------|
| Test Receiver KEYSIGHT | N9038A | MY55420137 | Apr. 16, 2020 | Apr. 15, 2021 |
| Spectrum Analyzer ROHDE & SCHWARZ | FSP40 | 100039 | Jun. 12, 2019 | Jun. 11, 2020 |
| Spectrum Analyzer ROHDE & SCHWARZ | FSV40 | 100980 | Apr. 23, 2019 | Apr. 22, 2020 |
| BILOG Antenna SCHWARZBECK | VULB9168 | 9168-160 | Nov. 07, 2019 | Nov. 06, 2020 |
| HORN Antenna SCHWARZBECK | BBHA 9120 D | 9120D-1169 | Nov. 24, 2019 | Nov. 23, 2020 |
| HORN Antenna SCHWARZBECK | BBHA 9170 | BBHA9170241 | Nov. 24, 2019 | Nov. 23, 2020 |
| Preamplifier Agilent (Below 1GHz) | 8447D | 2944A10638 | Jul. 11, 2019 | Jul. 10, 2020 |
| Preamplifier Agilent (Above 1GHz) | 8449B | 3008A02367 | Feb. 18, 2020 | Feb. 17, 2021 |
| RF signal cable HUBER+SUHNER&EMCI | SUCOFLEX 104 & EMC104-SM-SM80 00 | CABLE-CH9-02 (248780+171006) | Feb. 18, 2020 | Feb. 17, 2021 |
| RF signal cable HUBER+SUHNER | SUCOFLEX 104 | CABLE-CH9-(25079 5/4) | Jul. 11, 2019 | Jul. 10, 2020 |
| RF signal cable Woken | 8D-FB | Cable-CH9-01 | Jul. 30, 2019 | Jul. 29, 2020 |
| Software BV ADT | ADT_Radiated_ V7.6.15.9.5 | NA | NA | NA |
| Antenna Tower EMCO | 2070/2080 | 512.835.4684 | NA | NA |
| Turn Table EMCO | 2087-2.03 | NA | NA | NA |
| Antenna Tower &Turn BV ADT | AT100 | AT93021705 | NA | NA |
| Turn Table BV ADT | TT100 | TT93021705 | NA | NA |
| Turn Table Controller BV ADT | SC100 | SC93021705 | NA | NA |
| Boresight Antenna Fixture | FBA-01 | FBA-SIP01 | NA | NA |
| USB Wideband Power Sensor KEYSIGHT | U2021XA | MY55050005/MY55 190004/MY5519000 7/MY55210005 | Jul. 15, 2019 | Jul. 14, 2020 |

Note: 1. The calibration interval of the above test instruments is 12 months and the calibrations are traceable to NML/ROC and NIST/USA.
 2. The test was performed in HwaYa Chamber 9.

4.1.3 Test Procedures

For Radiated Emission below 30 MHz

- a. The EUT was placed on the top of a rotating table 0.8 meters above the ground at a 3 meter chamber room. The table was rotated 360 degrees to determine the position of the highest radiation.
- b. The EUT was set 3 meters away from the interference-receiving antenna, which was mounted on the top of a variable-height antenna tower.
- c. Parallel, perpendicular, and ground-parallel orientations of the antenna are set to make the measurement.
- d. For each suspected emission, the EUT was arranged to its worst case and the rotatable table was turned from 0 degrees to 360 degrees to find the maximum reading.
- e. The test-receiver system was set to Quasi-Peak Detect Function and Specified Bandwidth with Maximum Hold Mode.

Note:

1. The resolution bandwidth and video bandwidth of test receiver/spectrum analyzer is 9 kHz at frequency below 30 MHz.

For Radiated Emission above 30 MHz

- a. The EUT was placed on the top of a rotating table 0.8 meters (for 30 MHz ~ 1 GHz) / 1.5 meters (for above 1 GHz) above the ground at 3 meter chamber room for test. The table was rotated 360 degrees to determine the position of the highest radiation.
- b. The EUT was set 3 meters away from the interference-receiving antenna, which was mounted on the top of a variable-height antenna tower.
- c. The height of antenna is varied from one meter to four meters above the ground to determine the maximum value of the field strength. Both horizontal and vertical polarizations of the antenna are set to make the measurement.
- d. For each suspected emission, the EUT was arranged to its worst case and then the antenna was tuned to heights from 1 meter to 4 meters and the rotatable table was turned from 0 degrees to 360 degrees to find the maximum reading.
- e. The test-receiver system was set to quasi-peak detect function and specified bandwidth with maximum hold mode when the test frequency is below 1 GHz.
- f. The test-receiver system was set to peak and average detected function and specified bandwidth with maximum hold mode when the test frequency is above 1 GHz. If the peak reading value also meets average limit, measurement with the average detector is unnecessary.

Note:

1. The resolution bandwidth and video bandwidth of test receiver/spectrum analyzer is 120 kHz for Quasi-peak detection (QP) or Peak detection (PK) at frequency below 1 GHz.
2. The resolution bandwidth of test receiver/spectrum analyzer is 1 MHz and the video bandwidth is 3 MHz for Peak detection (PK) at frequency above 1 GHz.
3. The resolution bandwidth of test receiver/spectrum analyzer is 1 MHz and the video bandwidth is $\geq 1/T$ (Duty cycle < 98 %) or 10 Hz (Duty cycle ≥ 98 %) for Average detection (AV) at frequency above 1 GHz.
(11b: RBW = 1 MHz, VBW = 300 Hz ; 11g: RBW = 1 MHz, VBW = 1 kHz ;
11n (HT20): RBW = 1 MHz, VBW = 1 kHz)
4. All modes of operation were investigated and the worst-case emissions are reported.

4.1.4 Deviation from Test Standard

No deviation.

4.1.5 Test Set Up

<Radiated Emission below 30 MHz>

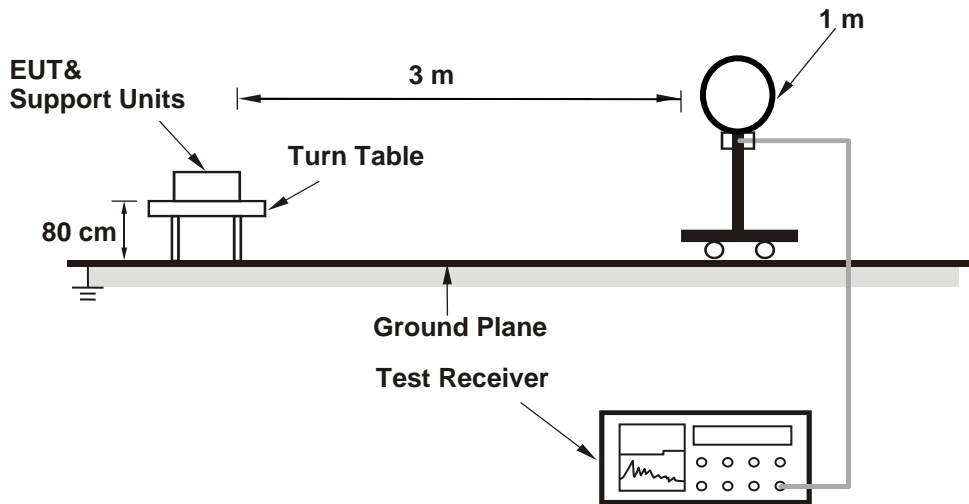

<Radiated Emission 30 MHz to 1 GHz>

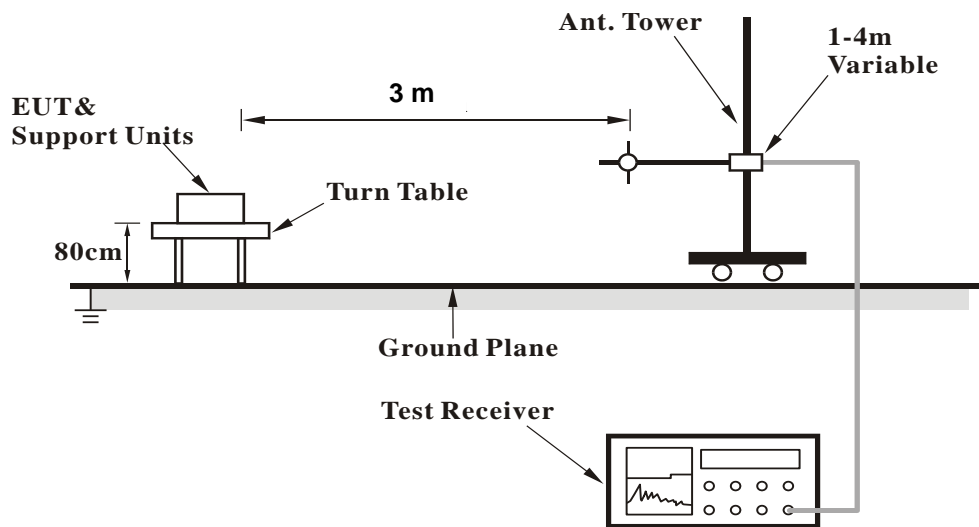

<Radiated Emission above 1 GHz>

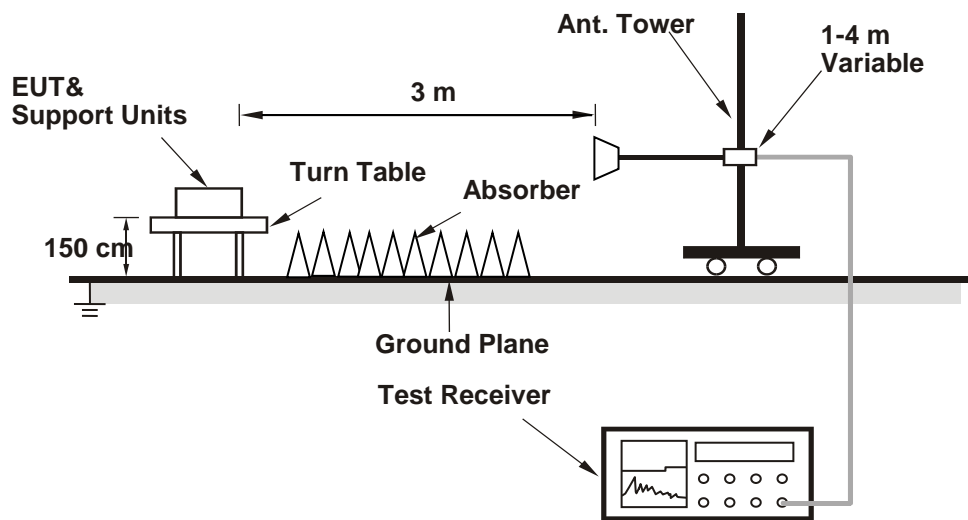

For the actual test configuration, please refer to the attached file (Test Setup Photo).

4.1.6 EUT Operating Conditions

- a. Placed the EUT on a testing table.
- b. Use the software to control the EUT under transmission condition continuously at specific channel frequency.

4.1.7 Test Results

Above 1 GHz Data :

802.11b

| | | | |
|------------------------|--------------|--------------------------|--------------|
| CHANNEL | TX Channel 1 | DETECTOR FUNCTION | Peak (PK) |
| FREQUENCY RANGE | 1GHz ~ 25GHz | | Average (AV) |

| ANTENNA POLARITY & TEST DISTANCE: HORIZONTAL AT 3 M | | | | | | | | |
|---|-------------|-------------------------|----------------|-------------|--------------------|----------------------|------------------|--------------------------|
| NO. | FREQ. (MHz) | EMISSION LEVEL (dBuV/m) | LIMIT (dBuV/m) | MARGIN (dB) | ANTENNA HEIGHT (m) | TABLE ANGLE (Degree) | RAW VALUE (dBuV) | CORRECTION FACTOR (dB/m) |
| 1 | 2390.00 | 53.0 PK | 74.0 | -21.0 | 1.00 H | 195 | 21.8 | 31.2 |
| 2 | 2390.00 | 41.0 AV | 54.0 | -13.0 | 1.00 H | 195 | 9.8 | 31.2 |
| 3 | *2412.00 | 100.6 PK | | | 1.00 H | 195 | 69.5 | 31.1 |
| 4 | *2412.00 | 96.9 AV | | | 1.00 H | 195 | 65.8 | 31.1 |
| 5 | 4824.00 | 42.1 PK | 74.0 | -31.9 | 3.40 H | 130 | 40.3 | 1.8 |
| 6 | 4824.00 | 28.3 AV | 54.0 | -25.7 | 3.40 H | 130 | 26.5 | 1.8 |

| ANTENNA POLARITY & TEST DISTANCE: VERTICAL AT 3 M | | | | | | | | |
|---|-------------|-------------------------|----------------|-------------|--------------------|----------------------|------------------|--------------------------|
| NO. | FREQ. (MHz) | EMISSION LEVEL (dBuV/m) | LIMIT (dBuV/m) | MARGIN (dB) | ANTENNA HEIGHT (m) | TABLE ANGLE (Degree) | RAW VALUE (dBuV) | CORRECTION FACTOR (dB/m) |
| 1 | 2390.00 | 53.7 PK | 74.0 | -20.3 | 1.96 V | 228 | 22.5 | 31.2 |
| 2 | 2390.00 | 41.2 AV | 54.0 | -12.8 | 1.96 V | 228 | 10.0 | 31.2 |
| 3 | *2412.00 | 102.0 PK | | | 1.96 V | 228 | 70.9 | 31.1 |
| 4 | *2412.00 | 98.6 AV | | | 1.96 V | 228 | 67.5 | 31.1 |
| 5 | 4824.00 | 41.8 PK | 74.0 | -32.2 | 3.22 V | 184 | 40.0 | 1.8 |
| 6 | 4824.00 | 28.5 AV | 54.0 | -25.5 | 3.22 V | 184 | 26.7 | 1.8 |

REMARKS:

1. Emission Level(dBuV/m) = Raw Value(dBuV) + Correction Factor(dB/m)
2. Correction Factor(dB/m) = Antenna Factor(dB/m) + Cable Factor(dB) – Pre-Amplifier Factor(dB)
3. Margin value = Emission Level – Limit value
4. The other emission levels were very low against the limit.
5. " * ": Fundamental frequency.

| | | | |
|------------------------|--------------|--------------------------|--------------|
| CHANNEL | TX Channel 6 | DETECTOR FUNCTION | Peak (PK) |
| FREQUENCY RANGE | 1GHz ~ 25GHz | | Average (AV) |

ANTENNA POLARITY & TEST DISTANCE: HORIZONTAL AT 3 M

| NO. | FREQ. (MHz) | EMISSION LEVEL (dBuV/m) | LIMIT (dBuV/m) | MARGIN (dB) | ANTENNA HEIGHT (m) | TABLE ANGLE (Degree) | RAW VALUE (dBuV) | CORRECTION FACTOR (dB/m) |
|-----|-------------|-------------------------|----------------|-------------|--------------------|----------------------|------------------|--------------------------|
| 1 | *2437.00 | 99.0 PK | | | 1.00 H | 196 | 67.9 | 31.1 |
| 2 | *2437.00 | 95.4 AV | | | 1.00 H | 196 | 64.3 | 31.1 |
| 3 | 4874.00 | 41.9 PK | 74.0 | -32.1 | 3.45 H | 123 | 39.9 | 2.0 |
| 4 | 4874.00 | 28.8 AV | 54.0 | -25.2 | 3.45 H | 123 | 26.8 | 2.0 |

ANTENNA POLARITY & TEST DISTANCE: VERTICAL AT 3 M

| NO. | FREQ. (MHz) | EMISSION LEVEL (dBuV/m) | LIMIT (dBuV/m) | MARGIN (dB) | ANTENNA HEIGHT (m) | TABLE ANGLE (Degree) | RAW VALUE (dBuV) | CORRECTION FACTOR (dB/m) |
|-----|-------------|-------------------------|----------------|-------------|--------------------|----------------------|------------------|--------------------------|
| 1 | *2437.00 | 100.9 PK | | | 2.08 V | 239 | 69.8 | 31.1 |
| 2 | *2437.00 | 97.2 AV | | | 2.08 V | 239 | 66.1 | 31.1 |
| 3 | 4874.00 | 42.0 PK | 74.0 | -32.0 | 3.15 V | 196 | 40.0 | 2.0 |
| 4 | 4874.00 | 28.4 AV | 54.0 | -25.6 | 3.15 V | 196 | 26.4 | 2.0 |

REMARKS:

1. Emission Level(dBuV/m) = Raw Value(dBuV) + Correction Factor(dB/m)
2. Correction Factor(dB/m) = Antenna Factor(dB/m) + Cable Factor(dB) – Pre-Amplifier Factor(dB)
3. Margin value = Emission Level – Limit value
4. The other emission levels were very low against the limit.
5. " * ": Fundamental frequency.

| | | | |
|------------------------|---------------|--------------------------|--------------|
| CHANNEL | TX Channel 11 | DETECTOR FUNCTION | Peak (PK) |
| FREQUENCY RANGE | 1GHz ~ 25GHz | | Average (AV) |

ANTENNA POLARITY & TEST DISTANCE: HORIZONTAL AT 3 M

| NO. | FREQ. (MHz) | EMISSION LEVEL (dBuV/m) | LIMIT (dBuV/m) | MARGIN (dB) | ANTENNA HEIGHT (m) | TABLE ANGLE (Degree) | RAW VALUE (dBuV) | CORRECTION FACTOR (dB/m) |
|-----|-------------|-------------------------|----------------|-------------|--------------------|----------------------|------------------|--------------------------|
| 1 | *2462.00 | 99.5 PK | | | 1.05 H | 194 | 68.4 | 31.1 |
| 2 | *2462.00 | 95.7 AV | | | 1.05 H | 194 | 64.6 | 31.1 |
| 3 | 2483.50 | 53.8 PK | 74.0 | -20.2 | 1.05 H | 194 | 22.6 | 31.2 |
| 4 | 2483.50 | 41.3 AV | 54.0 | -12.7 | 1.05 H | 194 | 10.1 | 31.2 |
| 5 | 4924.00 | 41.7 PK | 74.0 | -32.3 | 3.54 H | 121 | 39.6 | 2.1 |
| 6 | 4924.00 | 28.7 AV | 54.0 | -25.3 | 3.54 H | 121 | 26.6 | 2.1 |

ANTENNA POLARITY & TEST DISTANCE: VERTICAL AT 3 M

| NO. | FREQ. (MHz) | EMISSION LEVEL (dBuV/m) | LIMIT (dBuV/m) | MARGIN (dB) | ANTENNA HEIGHT (m) | TABLE ANGLE (Degree) | RAW VALUE (dBuV) | CORRECTION FACTOR (dB/m) |
|-----|-------------|-------------------------|----------------|-------------|--------------------|----------------------|------------------|--------------------------|
| 1 | *2462.00 | 101.0 PK | | | 2.04 V | 242 | 69.9 | 31.1 |
| 2 | *2462.00 | 97.3 AV | | | 2.04 V | 242 | 66.2 | 31.1 |
| 3 | 2483.50 | 53.9 PK | 74.0 | -20.1 | 2.04 V | 242 | 22.7 | 31.2 |
| 4 | 2483.50 | 41.1 AV | 54.0 | -12.9 | 2.04 V | 242 | 9.9 | 31.2 |
| 5 | 4924.00 | 41.9 PK | 74.0 | -32.1 | 3.19 V | 188 | 39.8 | 2.1 |
| 6 | 4924.00 | 28.8 AV | 54.0 | -25.2 | 3.19 V | 188 | 26.7 | 2.1 |

REMARKS:

1. Emission Level(dBuV/m) = Raw Value(dBuV) + Correction Factor(dB/m)
2. Correction Factor(dB/m) = Antenna Factor(dB/m) + Cable Factor(dB) – Pre-Amplifier Factor(dB)
3. Margin value = Emission Level – Limit value
4. The other emission levels were very low against the limit.
5. " * ": Fundamental frequency.

802.11g

| | | | |
|------------------------|--------------|--------------------------|--------------|
| CHANNEL | TX Channel 1 | DETECTOR FUNCTION | Peak (PK) |
| FREQUENCY RANGE | 1GHz ~ 25GHz | | Average (AV) |

ANTENNA POLARITY & TEST DISTANCE: HORIZONTAL AT 3 M

| NO. | FREQ. (MHz) | EMISSION LEVEL (dBuV/m) | LIMIT (dBuV/m) | MARGIN (dB) | ANTENNA HEIGHT (m) | TABLE ANGLE (Degree) | RAW VALUE (dBuV) | CORRECTION FACTOR (dB/m) |
|-----|-------------|-------------------------|----------------|-------------|--------------------|----------------------|------------------|--------------------------|
| 1 | 2390.00 | 54.7 PK | 74.0 | -19.3 | 1.18 H | 196 | 23.5 | 31.2 |
| 2 | 2390.00 | 41.2 AV | 54.0 | -12.8 | 1.18 H | 196 | 10.0 | 31.2 |
| 3 | *2412.00 | 100.6 PK | | | 1.18 H | 196 | 69.5 | 31.1 |
| 4 | *2412.00 | 90.0 AV | | | 1.18 H | 196 | 58.9 | 31.1 |
| 5 | 4824.00 | 41.6 PK | 74.0 | -32.4 | 3.49 H | 120 | 39.8 | 1.8 |
| 6 | 4824.00 | 28.5 AV | 54.0 | -25.5 | 3.49 H | 120 | 26.7 | 1.8 |

ANTENNA POLARITY & TEST DISTANCE: VERTICAL AT 3 M

| NO. | FREQ. (MHz) | EMISSION LEVEL (dBuV/m) | LIMIT (dBuV/m) | MARGIN (dB) | ANTENNA HEIGHT (m) | TABLE ANGLE (Degree) | RAW VALUE (dBuV) | CORRECTION FACTOR (dB/m) |
|-----|-------------|-------------------------|----------------|-------------|--------------------|----------------------|------------------|--------------------------|
| 1 | 2390.00 | 54.1 PK | 74.0 | -19.9 | 1.84 V | 243 | 22.9 | 31.2 |
| 2 | 2390.00 | 41.1 AV | 54.0 | -12.9 | 1.84 V | 243 | 9.9 | 31.2 |
| 3 | *2412.00 | 102.5 PK | | | 1.84 V | 243 | 71.4 | 31.1 |
| 4 | *2412.00 | 91.8 AV | | | 1.84 V | 243 | 60.7 | 31.1 |
| 5 | 4824.00 | 41.4 PK | 74.0 | -32.6 | 3.16 V | 187 | 39.6 | 1.8 |
| 6 | 4824.00 | 28.3 AV | 54.0 | -25.7 | 3.16 V | 187 | 26.5 | 1.8 |

REMARKS:

1. Emission Level(dBuV/m) = Raw Value(dBuV) + Correction Factor(dB/m)
2. Correction Factor(dB/m) = Antenna Factor(dB/m) + Cable Factor(dB) – Pre-Amplifier Factor(dB)
3. Margin value = Emission Level – Limit value
4. The other emission levels were very low against the limit.
5. " * ": Fundamental frequency.

| | | | |
|------------------------|--------------|--------------------------|--------------|
| CHANNEL | TX Channel 6 | DETECTOR FUNCTION | Peak (PK) |
| FREQUENCY RANGE | 1GHz ~ 25GHz | | Average (AV) |

ANTENNA POLARITY & TEST DISTANCE: HORIZONTAL AT 3 M

| NO. | FREQ. (MHz) | EMISSION LEVEL (dBuV/m) | LIMIT (dBuV/m) | MARGIN (dB) | ANTENNA HEIGHT (m) | TABLE ANGLE (Degree) | RAW VALUE (dBuV) | CORRECTION FACTOR (dB/m) |
|-----|-------------|-------------------------|----------------|-------------|--------------------|----------------------|------------------|--------------------------|
| 1 | *2437.00 | 100.5 PK | | | 1.01 H | 199 | 69.4 | 31.1 |
| 2 | *2437.00 | 90.7 AV | | | 1.01 H | 199 | 59.6 | 31.1 |
| 3 | 4874.00 | 42.0 PK | 74.0 | -32.0 | 3.44 H | 128 | 40.0 | 2.0 |
| 4 | 4874.00 | 28.8 AV | 54.0 | -25.2 | 3.44 H | 128 | 26.8 | 2.0 |

ANTENNA POLARITY & TEST DISTANCE: VERTICAL AT 3 M

| NO. | FREQ. (MHz) | EMISSION LEVEL (dBuV/m) | LIMIT (dBuV/m) | MARGIN (dB) | ANTENNA HEIGHT (m) | TABLE ANGLE (Degree) | RAW VALUE (dBuV) | CORRECTION FACTOR (dB/m) |
|-----|-------------|-------------------------|----------------|-------------|--------------------|----------------------|------------------|--------------------------|
| 1 | *2437.00 | 102.4 PK | | | 1.72 V | 240 | 71.3 | 31.1 |
| 2 | *2437.00 | 92.5 AV | | | 1.72 V | 240 | 61.4 | 31.1 |
| 3 | 4874.00 | 42.4 PK | 74.0 | -31.6 | 3.23 V | 193 | 40.4 | 2.0 |
| 4 | 4874.00 | 28.8 AV | 54.0 | -25.2 | 3.23 V | 193 | 26.8 | 2.0 |

REMARKS:

1. Emission Level(dBuV/m) = Raw Value(dBuV) + Correction Factor(dB/m)
2. Correction Factor(dB/m) = Antenna Factor(dB/m) + Cable Factor(dB) – Pre-Amplifier Factor(dB)
3. Margin value = Emission Level – Limit value
4. The other emission levels were very low against the limit.
5. " * ": Fundamental frequency.

| | | | |
|------------------------|---------------|--------------------------|--------------|
| CHANNEL | TX Channel 11 | DETECTOR FUNCTION | Peak (PK) |
| FREQUENCY RANGE | 1GHz ~ 25GHz | | Average (AV) |

ANTENNA POLARITY & TEST DISTANCE: HORIZONTAL AT 3 M

| NO. | FREQ. (MHz) | EMISSION LEVEL (dBuV/m) | LIMIT (dBuV/m) | MARGIN (dB) | ANTENNA HEIGHT (m) | TABLE ANGLE (Degree) | RAW VALUE (dBuV) | CORRECTION FACTOR (dB/m) |
|-----|-------------|-------------------------|----------------|-------------|--------------------|----------------------|------------------|--------------------------|
| 1 | *2462.00 | 100.0 PK | | | 1.14 H | 193 | 68.9 | 31.1 |
| 2 | *2462.00 | 90.2 AV | | | 1.14 H | 193 | 59.1 | 31.1 |
| 3 | 2483.50 | 57.4 PK | 74.0 | -16.6 | 1.14 H | 193 | 26.2 | 31.2 |
| 4 | 2483.50 | 43.1 AV | 54.0 | -10.9 | 1.14 H | 193 | 11.9 | 31.2 |
| 5 | 4924.00 | 42.2 PK | 74.0 | -31.8 | 3.40 H | 136 | 40.1 | 2.1 |
| 6 | 4924.00 | 28.7 AV | 54.0 | -25.3 | 3.40 H | 136 | 26.6 | 2.1 |

ANTENNA POLARITY & TEST DISTANCE: VERTICAL AT 3 M

| NO. | FREQ. (MHz) | EMISSION LEVEL (dBuV/m) | LIMIT (dBuV/m) | MARGIN (dB) | ANTENNA HEIGHT (m) | TABLE ANGLE (Degree) | RAW VALUE (dBuV) | CORRECTION FACTOR (dB/m) |
|-----|-------------|-------------------------|----------------|-------------|--------------------|----------------------|------------------|--------------------------|
| 1 | *2462.00 | 101.7 PK | | | 2.02 V | 222 | 70.6 | 31.1 |
| 2 | *2462.00 | 91.9 AV | | | 2.02 V | 222 | 60.8 | 31.1 |
| 3 | 2483.50 | 57.6 PK | 74.0 | -16.4 | 2.02 V | 222 | 26.4 | 31.2 |
| 4 | 2483.50 | 43.3 AV | 54.0 | -10.7 | 2.02 V | 222 | 12.1 | 31.2 |
| 5 | 4924.00 | 41.9 PK | 74.0 | -32.1 | 3.19 V | 180 | 39.8 | 2.1 |
| 6 | 4924.00 | 28.8 AV | 54.0 | -25.2 | 3.19 V | 180 | 26.7 | 2.1 |

REMARKS:

1. Emission Level(dBuV/m) = Raw Value(dBuV) + Correction Factor(dB/m)
2. Correction Factor(dB/m) = Antenna Factor(dB/m) + Cable Factor(dB) – Pre-Amplifier Factor(dB)
3. Margin value = Emission Level – Limit value
4. The other emission levels were very low against the limit.
5. " * ": Fundamental frequency.

802.11n (HT20)

| | | | |
|------------------------|--------------|--------------------------|--------------|
| CHANNEL | TX Channel 1 | DETECTOR FUNCTION | Peak (PK) |
| FREQUENCY RANGE | 1GHz ~ 25GHz | | Average (AV) |

ANTENNA POLARITY & TEST DISTANCE: HORIZONTAL AT 3 M

| NO. | FREQ. (MHz) | EMISSION LEVEL (dBuV/m) | LIMIT (dBuV/m) | MARGIN (dB) | ANTENNA HEIGHT (m) | TABLE ANGLE (Degree) | RAW VALUE (dBuV) | CORRECTION FACTOR (dB/m) |
|-----|-------------|-------------------------|----------------|-------------|--------------------|----------------------|------------------|--------------------------|
| 1 | 2390.00 | 54.5 PK | 74.0 | -19.5 | 1.05 H | 195 | 23.3 | 31.2 |
| 2 | 2390.00 | 41.4 AV | 54.0 | -12.6 | 1.05 H | 195 | 10.2 | 31.2 |
| 3 | *2412.00 | 100.3 PK | | | 1.05 H | 195 | 69.2 | 31.1 |
| 4 | *2412.00 | 90.1 AV | | | 1.05 H | 195 | 59.0 | 31.1 |
| 5 | 4824.00 | 41.4 PK | 74.0 | -32.6 | 3.46 H | 131 | 39.6 | 1.8 |
| 6 | 4824.00 | 28.2 AV | 54.0 | -25.8 | 3.46 H | 131 | 26.4 | 1.8 |

ANTENNA POLARITY & TEST DISTANCE: VERTICAL AT 3 M

| NO. | FREQ. (MHz) | EMISSION LEVEL (dBuV/m) | LIMIT (dBuV/m) | MARGIN (dB) | ANTENNA HEIGHT (m) | TABLE ANGLE (Degree) | RAW VALUE (dBuV) | CORRECTION FACTOR (dB/m) |
|-----|-------------|-------------------------|----------------|-------------|--------------------|----------------------|------------------|--------------------------|
| 1 | 2390.00 | 55.9 PK | 74.0 | -18.1 | 1.84 V | 242 | 24.7 | 31.2 |
| 2 | 2390.00 | 41.3 AV | 54.0 | -12.7 | 1.84 V | 242 | 10.1 | 31.2 |
| 3 | *2412.00 | 101.8 PK | | | 1.84 V | 242 | 70.7 | 31.1 |
| 4 | *2412.00 | 91.7 AV | | | 1.84 V | 242 | 60.6 | 31.1 |
| 5 | 4824.00 | 41.8 PK | 74.0 | -32.2 | 3.13 V | 183 | 40.0 | 1.8 |
| 6 | 4824.00 | 28.2 AV | 54.0 | -25.8 | 3.13 V | 183 | 26.4 | 1.8 |

REMARKS:

1. Emission Level(dBuV/m) = Raw Value(dBuV) + Correction Factor(dB/m)
2. Correction Factor(dB/m) = Antenna Factor(dB/m) + Cable Factor(dB) – Pre-Amplifier Factor(dB)
3. Margin value = Emission Level – Limit value
4. The other emission levels were very low against the limit.
5. " * ": Fundamental frequency.

| | | | |
|------------------------|--------------|--------------------------|--------------|
| CHANNEL | TX Channel 6 | DETECTOR FUNCTION | Peak (PK) |
| FREQUENCY RANGE | 1GHz ~ 25GHz | | Average (AV) |

ANTENNA POLARITY & TEST DISTANCE: HORIZONTAL AT 3 M

| NO. | FREQ. (MHz) | EMISSION LEVEL (dBuV/m) | LIMIT (dBuV/m) | MARGIN (dB) | ANTENNA HEIGHT (m) | TABLE ANGLE (Degree) | RAW VALUE (dBuV) | CORRECTION FACTOR (dB/m) |
|-----|-------------|-------------------------|----------------|-------------|--------------------|----------------------|------------------|--------------------------|
| 1 | *2437.00 | 101.2 PK | | | 1.17 H | 199 | 70.1 | 31.1 |
| 2 | *2437.00 | 90.7 AV | | | 1.17 H | 199 | 59.6 | 31.1 |
| 3 | 4874.00 | 41.9 PK | 74.0 | -32.1 | 3.39 H | 122 | 39.9 | 2.0 |
| 4 | 4874.00 | 28.6 AV | 54.0 | -25.4 | 3.39 H | 122 | 26.6 | 2.0 |

ANTENNA POLARITY & TEST DISTANCE: VERTICAL AT 3 M

| NO. | FREQ. (MHz) | EMISSION LEVEL (dBuV/m) | LIMIT (dBuV/m) | MARGIN (dB) | ANTENNA HEIGHT (m) | TABLE ANGLE (Degree) | RAW VALUE (dBuV) | CORRECTION FACTOR (dB/m) |
|-----|-------------|-------------------------|----------------|-------------|--------------------|----------------------|------------------|--------------------------|
| 1 | *2437.00 | 102.9 PK | | | 1.72 V | 242 | 71.8 | 31.1 |
| 2 | *2437.00 | 92.4 AV | | | 1.72 V | 242 | 61.3 | 31.1 |
| 3 | 4874.00 | 42.1 PK | 74.0 | -31.9 | 3.24 V | 187 | 40.1 | 2.0 |
| 4 | 4874.00 | 28.4 AV | 54.0 | -25.6 | 3.24 V | 187 | 26.4 | 2.0 |

REMARKS:

1. Emission Level(dBuV/m) = Raw Value(dBuV) + Correction Factor(dB/m)
2. Correction Factor(dB/m) = Antenna Factor(dB/m) + Cable Factor(dB) – Pre-Amplifier Factor(dB)
3. Margin value = Emission Level – Limit value
4. The other emission levels were very low against the limit.
5. " * ": Fundamental frequency.

| | | | |
|------------------------|---------------|--------------------------|--------------|
| CHANNEL | TX Channel 11 | DETECTOR FUNCTION | Peak (PK) |
| FREQUENCY RANGE | 1GHz ~ 25GHz | | Average (AV) |

ANTENNA POLARITY & TEST DISTANCE: HORIZONTAL AT 3 M

| NO. | FREQ. (MHz) | EMISSION LEVEL (dBuV/m) | LIMIT (dBuV/m) | MARGIN (dB) | ANTENNA HEIGHT (m) | TABLE ANGLE (Degree) | RAW VALUE (dBuV) | CORRECTION FACTOR (dB/m) |
|-----|-------------|-------------------------|----------------|-------------|--------------------|----------------------|------------------|--------------------------|
| 1 | *2462.00 | 101.2 PK | | | 1.17 H | 199 | 70.1 | 31.1 |
| 2 | *2462.00 | 90.7 AV | | | 1.17 H | 199 | 59.6 | 31.1 |
| 3 | 2483.50 | 58.7 PK | 74.0 | -15.3 | 1.17 H | 199 | 27.5 | 31.2 |
| 4 | 2483.50 | 43.7 AV | 54.0 | -10.3 | 1.17 H | 199 | 12.5 | 31.2 |
| 5 | 4924.00 | 42.0 PK | 74.0 | -32.0 | 3.39 H | 122 | 39.9 | 2.1 |
| 6 | 4924.00 | 28.7 AV | 54.0 | -25.3 | 3.39 H | 122 | 26.6 | 2.1 |

ANTENNA POLARITY & TEST DISTANCE: VERTICAL AT 3 M

| NO. | FREQ. (MHz) | EMISSION LEVEL (dBuV/m) | LIMIT (dBuV/m) | MARGIN (dB) | ANTENNA HEIGHT (m) | TABLE ANGLE (Degree) | RAW VALUE (dBuV) | CORRECTION FACTOR (dB/m) |
|-----|-------------|-------------------------|----------------|-------------|--------------------|----------------------|------------------|--------------------------|
| 1 | *2462.00 | 102.2 PK | | | 1.76 V | 243 | 71.1 | 31.1 |
| 2 | *2462.00 | 92.2 AV | | | 1.76 V | 243 | 61.1 | 31.1 |
| 3 | 2483.50 | 60.6 PK | 74.0 | -13.4 | 1.76 V | 243 | 29.4 | 31.2 |
| 4 | 2483.50 | 44.0 AV | 54.0 | -10.0 | 1.76 V | 243 | 12.8 | 31.2 |
| 5 | 4924.00 | 42.2 PK | 74.0 | -31.8 | 3.24 V | 187 | 40.1 | 2.1 |
| 6 | 4924.00 | 28.5 AV | 54.0 | -25.5 | 3.24 V | 187 | 26.4 | 2.1 |

REMARKS:

1. Emission Level(dBuV/m) = Raw Value(dBuV) + Correction Factor(dB/m)
2. Correction Factor(dB/m) = Antenna Factor(dB/m) + Cable Factor(dB) – Pre-Amplifier Factor(dB)
3. Margin value = Emission Level – Limit value
4. The other emission levels were very low against the limit.
5. " * ": Fundamental frequency.

30 MHz ~ 1 GHz Worst-Case Data:

Mode A

802.11n (HT20)

| | | | |
|------------------------|---------------|--------------------------|-----------------|
| CHANNEL | TX Channel 11 | DETECTOR FUNCTION | Quasi-Peak (QP) |
| FREQUENCY RANGE | 30MHz ~ 1GHz | | |

| ANTENNA POLARITY & TEST DISTANCE: HORIZONTAL AT 3 M | | | | | | | | |
|---|-------------|-------------------------|----------------|-------------|--------------------|----------------------|------------------|--------------------------|
| NO. | FREQ. (MHz) | EMISSION LEVEL (dBuV/m) | LIMIT (dBuV/m) | MARGIN (dB) | ANTENNA HEIGHT (m) | TABLE ANGLE (Degree) | RAW VALUE (dBuV) | CORRECTION FACTOR (dB/m) |
| 1 | 49.40 | 26.9 QP | 40.0 | -13.1 | 1.00 H | 166 | 36.6 | -9.7 |
| 2 | 69.77 | 28.7 QP | 40.0 | -11.3 | 1.00 H | 3 | 40.2 | -11.5 |
| 3 | 89.17 | 25.0 QP | 43.5 | -18.5 | 1.00 H | 263 | 39.9 | -14.9 |
| 4 | 107.60 | 22.6 QP | 43.5 | -20.9 | 1.00 H | 222 | 35.2 | -12.6 |
| 5 | 297.72 | 29.7 QP | 46.0 | -16.3 | 1.00 H | 273 | 37.7 | -8.0 |
| 6 | 373.38 | 33.4 QP | 46.0 | -12.6 | 1.00 H | 218 | 39.6 | -6.2 |

REMARKS:

1. Emission Level(dBuV/m) = Raw Value(dBuV) + Correction Factor(dB/m)
2. Correction Factor(dB/m) = Antenna Factor(dB/m) + Cable Factor(dB) – Pre-Amplifier Factor(dB)
3. Margin value = Emission Level – Limit value
4. The other emission levels were very low against the limit of frequency range 30MHz~1000MHz.
5. The emission levels were very low against the limit of frequency range 9kHz~30MHz: the amplitude of spurious emissions attenuated more than 20 dB below the permissible value to be report.

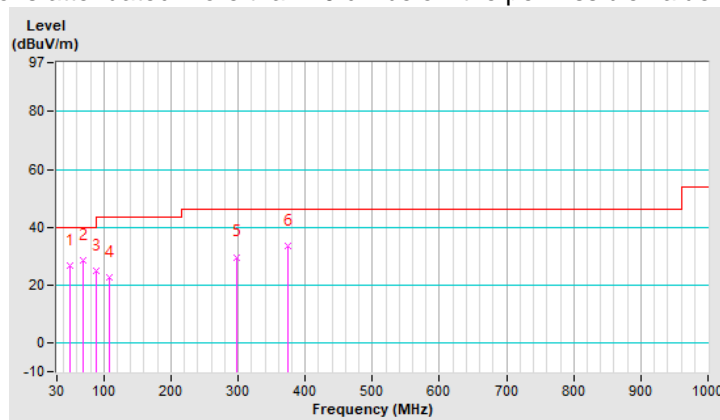

| | | | |
|------------------------|---------------|--------------------------|-----------------|
| CHANNEL | TX Channel 11 | DETECTOR FUNCTION | Quasi-Peak (QP) |
| FREQUENCY RANGE | 30MHz ~ 1GHz | | |

ANTENNA POLARITY & TEST DISTANCE: VERTICAL AT 3 M

| NO. | FREQ. (MHz) | EMISSION LEVEL (dBuV/m) | LIMIT (dBuV/m) | MARGIN (dB) | ANTENNA HEIGHT (m) | TABLE ANGLE (Degree) | RAW VALUE (dBuV) | CORRECTION FACTOR (dB/m) |
|-----|-------------|-------------------------|----------------|-------------|--------------------|----------------------|------------------|--------------------------|
| 1 | 52.31 | 31.8 QP | 40.0 | -8.2 | 1.00 V | 250 | 41.6 | -9.8 |
| 2 | 77.53 | 27.1 QP | 40.0 | -12.9 | 1.00 V | 14 | 40.5 | -13.4 |
| 3 | 111.48 | 27.0 QP | 43.5 | -16.5 | 1.00 V | 248 | 39.5 | -12.5 |
| 4 | 170.65 | 34.6 QP | 43.5 | -8.9 | 1.00 V | 248 | 44.1 | -9.5 |
| 5 | 233.70 | 30.8 QP | 46.0 | -15.2 | 1.00 V | 248 | 41.9 | -11.1 |
| 6 | 360.77 | 26.9 QP | 46.0 | -19.1 | 1.00 V | 55 | 33.5 | -6.6 |

REMARKS:

1. Emission Level(dBuV/m) = Raw Value(dBuV) + Correction Factor(dB/m)
2. Correction Factor(dB/m) = Antenna Factor(dB/m) + Cable Factor(dB) – Pre-Amplifier Factor(dB)
3. Margin value = Emission Level – Limit value
4. The other emission levels were very low against the limit of frequency range 30MHz~1000MHz.
5. The emission levels were very low against the limit of frequency range 9kHz~30MHz: the amplitude of spurious emissions attenuated more than 20 dB below the permissible value to be report.

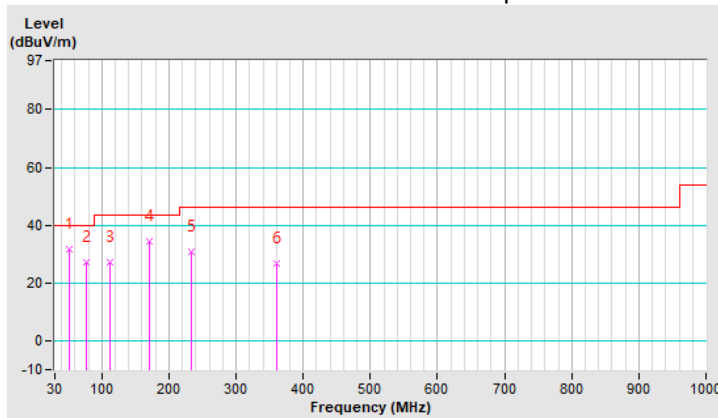

Mode B

| | | | |
|------------------------|---------------|--------------------------|-----------------|
| CHANNEL | TX Channel 11 | DETECTOR FUNCTION | Quasi-Peak (QP) |
| FREQUENCY RANGE | 30MHz ~ 1GHz | | |

| ANTENNA POLARITY & TEST DISTANCE: HORIZONTAL AT 3 M | | | | | | | | |
|---|-------------|-------------------------|----------------|-------------|--------------------|----------------------|------------------|--------------------------|
| NO. | FREQ. (MHz) | EMISSION LEVEL (dBuV/m) | LIMIT (dBuV/m) | MARGIN (dB) | ANTENNA HEIGHT (m) | TABLE ANGLE (Degree) | RAW VALUE (dBuV) | CORRECTION FACTOR (dB/m) |
| 1 | 49.40 | 26.9 QP | 40.0 | -13.1 | 1.25 H | 166 | 36.6 | -9.7 |
| 2 | 76.56 | 26.4 QP | 40.0 | -13.6 | 1.00 H | 26 | 39.6 | -13.2 |
| 3 | 245.34 | 22.5 QP | 46.0 | -23.5 | 1.00 H | 279 | 32.6 | -10.1 |
| 4 | 308.39 | 28.2 QP | 46.0 | -17.8 | 1.00 H | 116 | 36.0 | -7.8 |
| 5 | 383.08 | 30.2 QP | 46.0 | -15.8 | 1.50 H | 215 | 36.2 | -6.0 |
| 6 | 974.78 | 34.1 QP | 54.0 | -19.9 | 1.25 H | 54 | 29.1 | 5.0 |

REMARKS:

1. Emission Level(dBuV/m) = Raw Value(dBuV) + Correction Factor(dB/m)
2. Correction Factor(dB/m) = Antenna Factor(dB/m) + Cable Factor(dB) – Pre-Amplifier Factor(dB)
3. Margin value = Emission Level – Limit value
4. The other emission levels were very low against the limit of frequency range 30MHz~1000MHz.
5. The emission levels were very low against the limit of frequency range 9kHz~30MHz: the amplitude of spurious emissions attenuated more than 20 dB below the permissible value to be report.

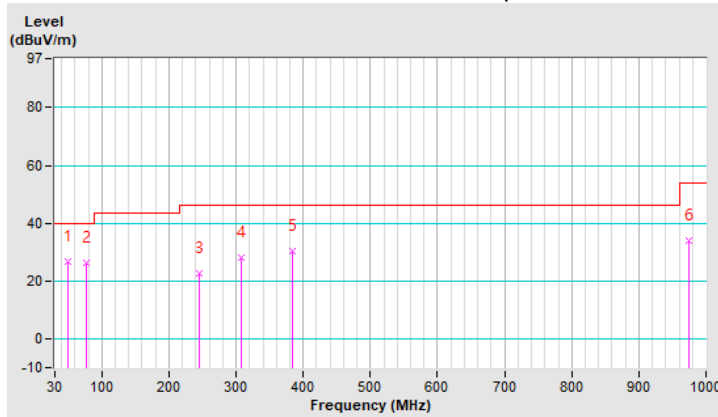

| | | | |
|------------------------|---------------|--------------------------|-----------------|
| CHANNEL | TX Channel 11 | DETECTOR FUNCTION | Quasi-Peak (QP) |
| FREQUENCY RANGE | 30MHz ~ 1GHz | | |

ANTENNA POLARITY & TEST DISTANCE: VERTICAL AT 3 M

| NO. | FREQ. (MHz) | EMISSION LEVEL (dBuV/m) | LIMIT (dBuV/m) | MARGIN (dB) | ANTENNA HEIGHT (m) | TABLE ANGLE (Degree) | RAW VALUE (dBuV) | CORRECTION FACTOR (dB/m) |
|-----|-------------|-------------------------|----------------|-------------|--------------------|----------------------|------------------|--------------------------|
| 1 | 31.94 | 31.7 QP | 40.0 | -8.3 | 1.25 V | 76 | 43.1 | -11.4 |
| 2 | 46.49 | 31.1 QP | 40.0 | -8.9 | 1.25 V | 79 | 40.9 | -9.8 |
| 3 | 162.89 | 33.2 QP | 43.5 | -10.3 | 1.05 V | 248 | 42.3 | -9.1 |
| 4 | 237.58 | 27.8 QP | 46.0 | -18.2 | 1.00 V | 248 | 38.5 | -10.7 |
| 5 | 612.97 | 27.5 QP | 46.0 | -18.5 | 1.25 V | 156 | 29.2 | -1.7 |
| 6 | 909.79 | 34.4 QP | 46.0 | -11.6 | 1.00 V | 172 | 30.6 | 3.8 |

REMARKS:

1. Emission Level(dBuV/m) = Raw Value(dBuV) + Correction Factor(dB/m)
2. Correction Factor(dB/m) = Antenna Factor(dB/m) + Cable Factor(dB) – Pre-Amplifier Factor(dB)
3. Margin value = Emission Level – Limit value
4. The other emission levels were very low against the limit of frequency range 30MHz~1000MHz.
5. The emission levels were very low against the limit of frequency range 9kHz~30MHz: the amplitude of spurious emissions attenuated more than 20 dB below the permissible value to be report.

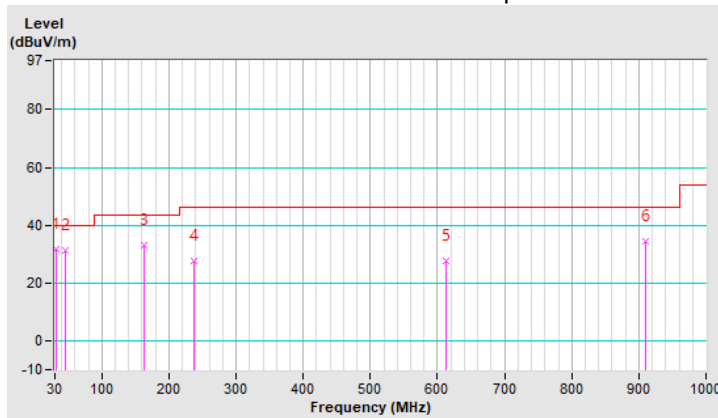

4.2 Conducted Emission Measurement

4.2.1 Limits of Conducted Emission Measurement

| Frequency (MHz) | Conducted Limit (dBuV) | |
|-----------------|------------------------|---------|
| | Quasi-Peak | Average |
| 0.15 - 0.5 | 66 - 56 | 56 - 46 |
| 0.50 - 5.0 | 56 | 46 |
| 5.0 - 30.0 | 60 | 50 |

- Note: 1. The lower limit shall apply at the transition frequencies.
 2. The limit decreases in line with the logarithm of the frequency in the range of 0.15 to 0.50 MHz.

4.2.2 Test Instruments

| Description & Manufacturer | Model No. | Serial No. | Date of Calibration | Due Date of Calibration |
|---|--------------------------|----------------|---------------------|-------------------------|
| Test Receiver ROHDE & SCHWARZ | ESR3 | 102412 | Feb. 17, 2020 | Feb. 16, 2021 |
| RF signal cable Woken | 5D-FB | Cable-cond2-01 | Sep. 05, 2019 | Sep. 04, 2020 |
| LISN ROHDE & SCHWARZ (EUT) | ESH2-Z5 | 100100 | Jan. 20, 2020 | Jan. 19, 2021 |
| LISN ROHDE & SCHWARZ (Peripheral) | ESH3-Z5 | 100312 | Aug. 13, 2019 | Aug. 12, 2020 |
| Software ADT | BV ADT_Cond_ V7.3.7.4 | NA | NA | NA |

- Note: 1. The calibration interval of the above test instruments is 12 months and the calibrations are traceable to NML/ROC and NIST/USA.
 2. The test was performed in HwaYa Shielded Room 2.
 3. The VCCI Site Registration No. is C-12047.

4.2.3 Test Procedures

- The EUT was placed 0.4 meters from the conducting wall of the shielded room with EUT being connected to the power mains through a line impedance stabilization network (LISN). Other support units were connected to the power mains through another LISN. The two LISNs provide 50 ohm/50 uH of coupling impedance for the measuring instrument.
- Both lines of the power mains connected to the EUT were checked for maximum conducted interference.
- The frequency range from 150 kHz to 30 MHz was searched. Emission levels under (Limit – 20 dB) was not recorded.

Note: The resolution bandwidth and video bandwidth of test receiver is 9 kHz for quasi-peak detection (QP) and average detection (AV) at frequency 0.15 MHz – 30 MHz.

4.2.4 Deviation from Test Standard

No deviation.

4.2.5 Test Setup

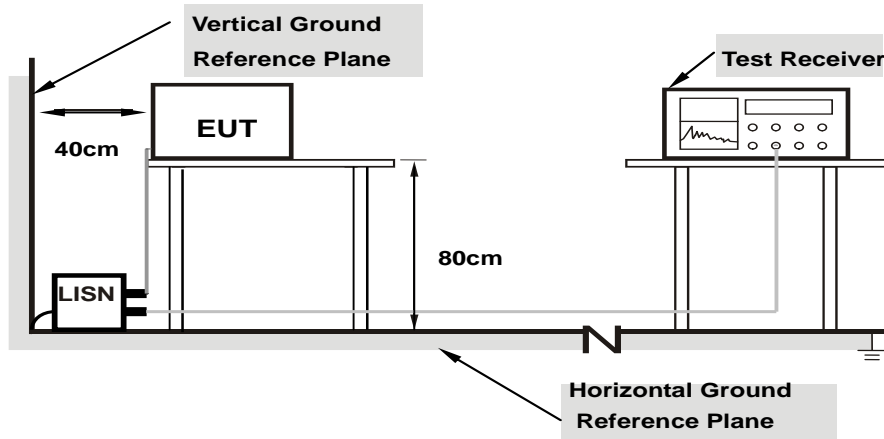

Note: 1.Support units were connected to second LISN.

For the actual test configuration, please refer to the attached file (Test Setup Photo).

4.2.6 EUT Operating Conditions

- Placed the EUT on a testing table.
- Use the software to control the EUT under transmission condition continuously at specific channel frequency.

4.2.7 Test Results

| | | | |
|-----------------|----------------|--|--------------------------------------|
| Frequency Range | 150kHz ~ 30MHz | Detector Function & Resolution Bandwidth | Quasi-Peak (QP) / Average (AV), 9kHz |
| Input Power | 120Vac, 60Hz | Environmental Conditions | 25°C, 75%RH |
| Tested by | Greg Lin | Test Date | 2020/4/18 |
| Test Mode | Mode A | | |

| Phase Of Power : Line (L) | | | | | | | | | | |
|---------------------------|-----------------|------------------------|----------------------|-------|-----------------------|-------|--------------|-------|-------------|--------|
| No | Frequency (MHz) | Correction Factor (dB) | Reading Value (dBuV) | | Emission Level (dBuV) | | Limit (dBuV) | | Margin (dB) | |
| | | | Q.P. | AV. | Q.P. | AV. | Q.P. | AV. | Q.P. | AV. |
| 1 | 0.19297 | 0.21 | 16.36 | 9.77 | 16.57 | 9.98 | 63.91 | 53.91 | -47.34 | -43.93 |
| 2 | 0.23203 | 0.21 | 15.14 | 9.20 | 15.35 | 9.41 | 62.38 | 52.38 | -47.03 | -42.97 |
| 3 | 0.56016 | 0.25 | 27.90 | 23.44 | 28.15 | 23.69 | 56.00 | 46.00 | -27.85 | -22.31 |
| 4 | 0.82578 | 0.28 | 15.73 | 10.27 | 16.01 | 10.55 | 56.00 | 46.00 | -39.99 | -35.45 |
| 5 | 1.75781 | 0.34 | 16.07 | 9.13 | 16.41 | 9.47 | 56.00 | 46.00 | -39.59 | -36.53 |
| 6 | 3.70313 | 0.41 | 15.59 | 7.63 | 16.00 | 8.04 | 56.00 | 46.00 | -40.00 | -37.96 |

Remarks:

1. Q.P. and AV. are abbreviations of quasi-peak and average individually.
2. The emission levels of other frequencies were very low against the limit.
3. Margin value = Emission level – Limit value
4. Correction factor = Insertion loss + Cable loss
5. Emission Level = Correction Factor + Reading Value

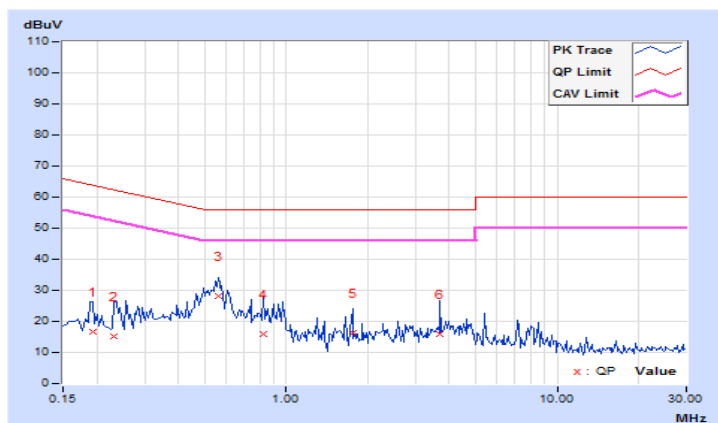

| | | | |
|-----------------|----------------|--|--------------------------------------|
| Frequency Range | 150kHz ~ 30MHz | Detector Function & Resolution Bandwidth | Quasi-Peak (QP) / Average (AV), 9kHz |
| Input Power | 120Vac, 60Hz | Environmental Conditions | 25°C, 75%RH |
| Tested by | Greg Lin | Test Date | 2020/4/18 |
| Test Mode | Mode A | | |

| Phase Of Power : Neutral (N) | | | | | | | | | | |
|------------------------------|-----------------|------------------------|----------------------|-------|-----------------------|-------|--------------|-------|-------------|--------|
| No | Frequency (MHz) | Correction Factor (dB) | Reading Value (dBuV) | | Emission Level (dBuV) | | Limit (dBuV) | | Margin (dB) | |
| | | | Q.P. | AV. | Q.P. | AV. | Q.P. | AV. | Q.P. | AV. |
| 1 | 0.15000 | 0.16 | 17.44 | 11.16 | 17.60 | 11.32 | 66.00 | 56.00 | -48.40 | -44.68 |
| 2 | 0.24375 | 0.18 | 14.56 | 8.17 | 14.74 | 8.35 | 61.97 | 51.97 | -47.23 | -43.62 |
| 3 | 0.47031 | 0.22 | 17.59 | 11.01 | 17.81 | 11.23 | 56.51 | 46.51 | -38.70 | -35.28 |
| 4 | 0.55625 | 0.23 | 25.44 | 18.36 | 25.67 | 18.59 | 56.00 | 46.00 | -30.33 | -27.41 |
| 5 | 0.94297 | 0.27 | 15.17 | 7.85 | 15.44 | 8.12 | 56.00 | 46.00 | -40.56 | -37.88 |
| 6 | 4.72266 | 0.44 | 13.74 | 3.26 | 14.18 | 3.70 | 56.00 | 46.00 | -41.82 | -42.30 |

Remarks:

1. Q.P. and AV. are abbreviations of quasi-peak and average individually.
2. The emission levels of other frequencies were very low against the limit.
3. Margin value = Emission level – Limit value
4. Correction factor = Insertion loss + Cable loss
5. Emission Level = Correction Factor + Reading Value

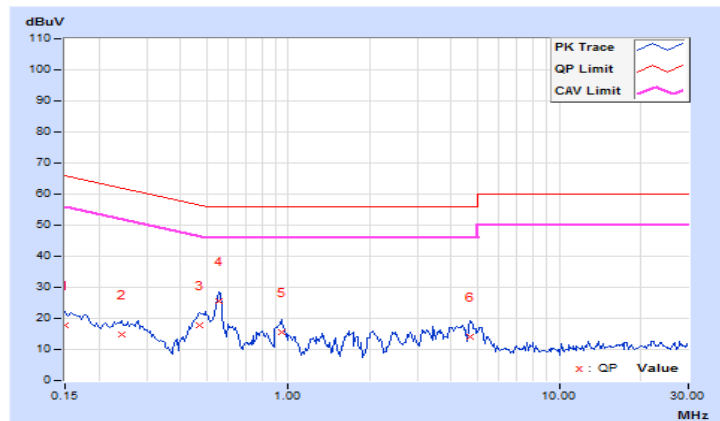

| | | | |
|-----------------|----------------|--|--------------------------------------|
| Frequency Range | 150kHz ~ 30MHz | Detector Function & Resolution Bandwidth | Quasi-Peak (QP) / Average (AV), 9kHz |
| Input Power | 120Vac, 60Hz | Environmental Conditions | 25°C, 75%RH |
| Tested by | Greg Lin | Test Date | 2020/4/17 |
| Test Mode | Mode B | | |

| Phase Of Power : Line (L) | | | | | | | | | | |
|---------------------------|-----------------|------------------------|----------------------|-------|-----------------------|-------|--------------|-------|-------------|--------|
| No | Frequency (MHz) | Correction Factor (dB) | Reading Value (dBuV) | | Emission Level (dBuV) | | Limit (dBuV) | | Margin (dB) | |
| | | | Q.P. | AV. | Q.P. | AV. | Q.P. | AV. | Q.P. | AV. |
| 1 | 0.15000 | 0.14 | 38.51 | 24.42 | 38.65 | 24.56 | 66.00 | 56.00 | -27.35 | -31.44 |
| 2 | 0.17344 | 0.15 | 31.69 | 13.15 | 31.84 | 13.30 | 64.79 | 54.79 | -32.95 | -41.49 |
| 3 | 0.21250 | 0.16 | 27.90 | 12.00 | 28.06 | 12.16 | 63.11 | 53.11 | -35.05 | -40.95 |
| 4 | 0.27500 | 0.17 | 21.09 | 12.67 | 21.26 | 12.84 | 60.97 | 50.97 | -39.71 | -38.13 |
| 5 | 0.51328 | 0.21 | 21.70 | 10.84 | 21.91 | 11.05 | 56.00 | 46.00 | -34.09 | -34.95 |
| 6 | 14.74609 | 0.55 | 29.90 | 23.67 | 30.45 | 24.22 | 60.00 | 50.00 | -29.55 | -25.78 |

Remarks:

1. Q.P. and AV. are abbreviations of quasi-peak and average individually.
2. The emission levels of other frequencies were very low against the limit.
3. Margin value = Emission level – Limit value
4. Correction factor = Insertion loss + Cable loss
5. Emission Level = Correction Factor + Reading Value

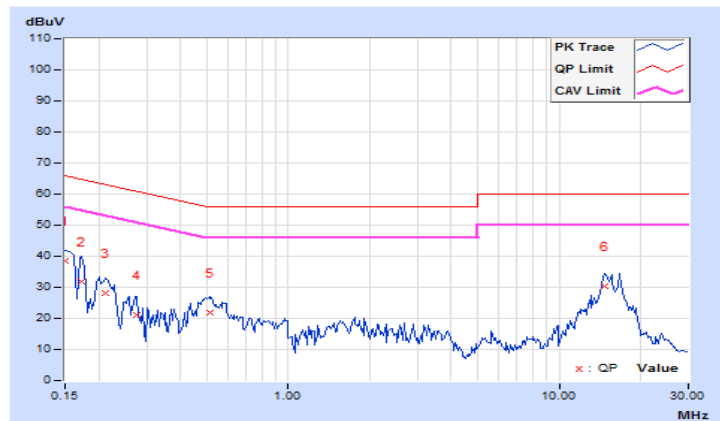

| | | | |
|-----------------|----------------|--|--------------------------------------|
| Frequency Range | 150kHz ~ 30MHz | Detector Function & Resolution Bandwidth | Quasi-Peak (QP) / Average (AV), 9kHz |
| Input Power | 120Vac, 60Hz | Environmental Conditions | 25°C, 75%RH |
| Tested by | Greg Lin | Test Date | 2020/4/17 |
| Test Mode | Mode B | | |

| Phase Of Power : Neutral (N) | | | | | | | | | | |
|------------------------------|-----------------|------------------------|----------------------|-------|-----------------------|-------|--------------|-------|-------------|--------|
| No | Frequency (MHz) | Correction Factor (dB) | Reading Value (dBuV) | | Emission Level (dBuV) | | Limit (dBuV) | | Margin (dB) | |
| | | | Q.P. | AV. | Q.P. | AV. | Q.P. | AV. | Q.P. | AV. |
| 1 | 0.15000 | 0.13 | 35.85 | 17.76 | 35.98 | 17.89 | 66.00 | 56.00 | -30.02 | -38.11 |
| 2 | 0.16953 | 0.13 | 32.07 | 16.36 | 32.20 | 16.49 | 64.98 | 54.98 | -32.78 | -38.49 |
| 3 | 0.21250 | 0.14 | 26.80 | 10.76 | 26.94 | 10.90 | 63.11 | 53.11 | -36.17 | -42.21 |
| 4 | 0.27109 | 0.15 | 22.31 | 10.38 | 22.46 | 10.53 | 61.08 | 51.08 | -38.62 | -40.55 |
| 5 | 0.52891 | 0.20 | 23.17 | 15.49 | 23.37 | 15.69 | 56.00 | 46.00 | -32.63 | -30.31 |
| 6 | 15.35938 | 0.65 | 30.61 | 24.27 | 31.26 | 24.92 | 60.00 | 50.00 | -28.74 | -25.08 |

Remarks:

1. Q.P. and AV. are abbreviations of quasi-peak and average individually.
2. The emission levels of other frequencies were very low against the limit.
3. Margin value = Emission level – Limit value
4. Correction factor = Insertion loss + Cable loss
5. Emission Level = Correction Factor + Reading Value

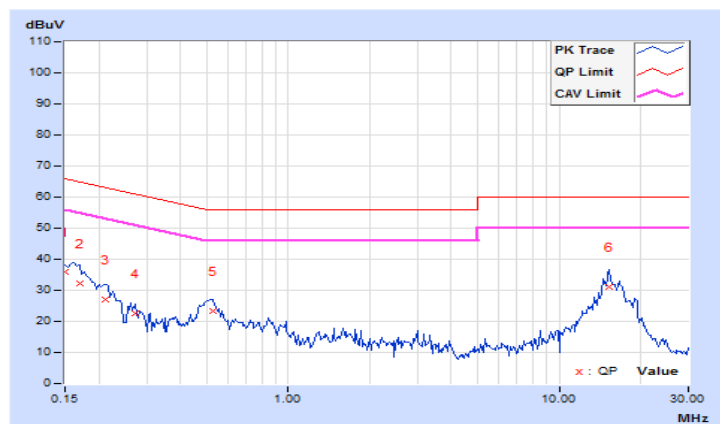

4.3 6 dB Bandwidth Measurement

4.3.1 Limits of 6 dB Bandwidth Measurement

The minimum of 6 dB Bandwidth Measurement is 0.5 MHz.

4.3.2 Test Setup

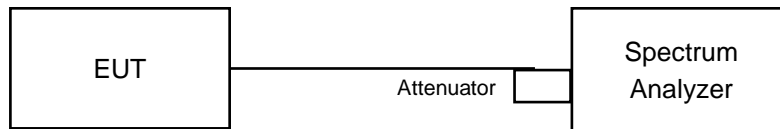

4.3.3 Test Instruments

Refer to section 4.1.2 to get information of above instrument.

4.3.4 Test Procedure

- a. Set resolution bandwidth (RBW) = 100 kHz
- b. Set the video bandwidth (VBW) $\geq 3 \times$ RBW, Detector = Peak.
- c. Trace mode = max hold.
- d. Sweep = auto couple.
- e. Measure the maximum width of the emission that is constrained by the frequencies associated with the two amplitude points (upper and lower) that are attenuated by 6 dB relative to the maximum level measured in the fundamental emission

4.3.5 Deviation from Test Standard

No deviation.

4.3.6 EUT Operating Conditions

The software provided by client to enable the EUT under transmission condition continuously at lowest, middle and highest channel frequencies individually.

4.3.7 Test Results

802.11b

| Channel | Frequency (MHz) | 6 dB Bandwidth (MHz) | Minimum Limit (MHz) | Pass / Fail |
|---------|-----------------|----------------------|---------------------|-------------|
| 1 | 2412 | 8.61 | 0.5 | Pass |
| 6 | 2437 | 8.57 | 0.5 | Pass |
| 11 | 2462 | 8.60 | 0.5 | Pass |

802.11g

| Channel | Frequency (MHz) | 6 dB Bandwidth (MHz) | Minimum Limit (MHz) | Pass / Fail |
|---------|-----------------|----------------------|---------------------|-------------|
| 1 | 2412 | 16.41 | 0.5 | Pass |
| 6 | 2437 | 16.40 | 0.5 | Pass |
| 11 | 2462 | 16.10 | 0.5 | Pass |

802.11n (HT20)

| Channel | Frequency (MHz) | 6 dB Bandwidth (MHz) | Minimum Limit (MHz) | Pass / Fail |
|---------|-----------------|----------------------|---------------------|-------------|
| 1 | 2412 | 17.61 | 0.5 | Pass |
| 6 | 2437 | 17.62 | 0.5 | Pass |
| 11 | 2462 | 17.37 | 0.5 | Pass |

Spectrum Plot of Worst Value

802.11b

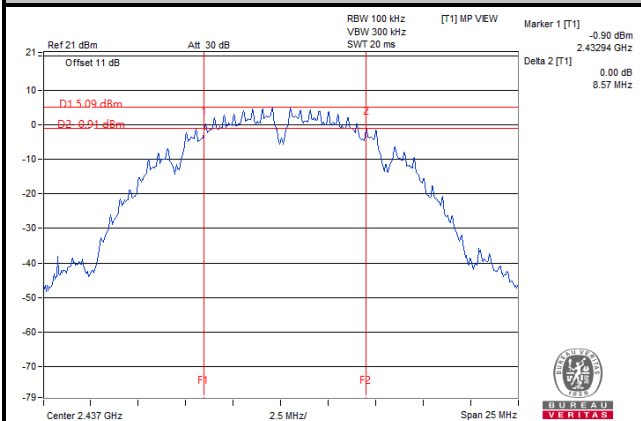

802.11g

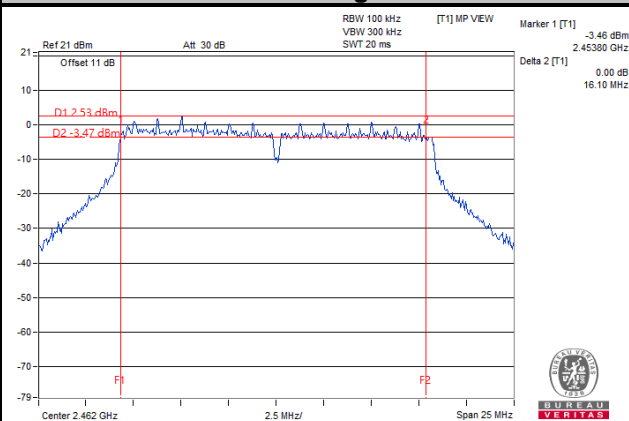

802.11n (HT20)

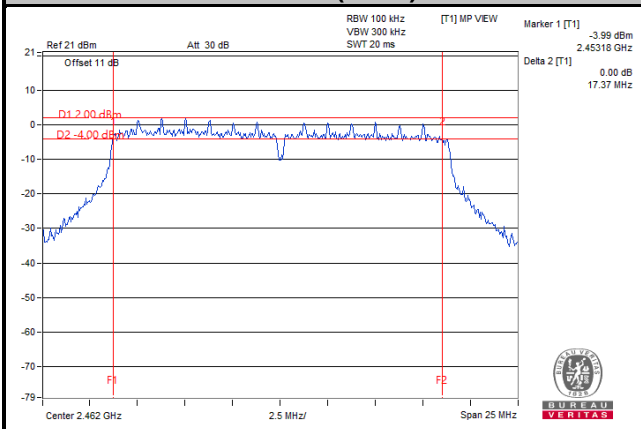

4.4 Occupied Bandwidth Measurement

4.4.1 Test Setup

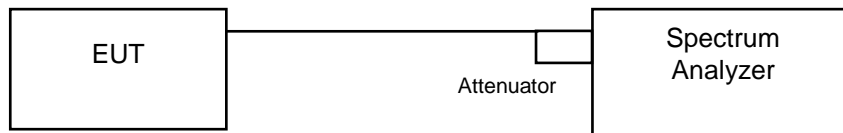

4.4.2 Test Instruments

Refer to section 4.1.2 to get information of above instrument.

4.4.3 Test Procedure

The transmitter output was connected to the spectrum analyzer through an attenuator. The bandwidth of the fundamental frequency was measured by spectrum analyzer with resolution bandwidth in the range of 1 % to 5 % of the anticipated emission bandwidth, and a video bandwidth at least 3x the resolution bandwidth and set the detector to sampling. The width of a frequency band such that, below the lower and above the upper frequency limits, the mean powers emitted are each equal to a specified percentage 0.5 % of the total mean power of a given emission.

4.4.4 Deviation from Test Standard

No deviation.

4.4.5 EUT Operating Conditions

The software provided by client to enable the EUT under transmission condition continuously at lowest, middle and highest channel frequencies individually.

4.4.6 Test Results

802.11b

| Channel | Frequency (MHz) | Occupied Bandwidth (MHz) | Pass / Fail |
|---------|-----------------|--------------------------|-------------|
| 1 | 2412 | 13.08 | Pass |
| 6 | 2437 | 13.20 | Pass |
| 11 | 2462 | 13.20 | Pass |

802.11g

| Channel | Frequency (MHz) | Occupied Bandwidth (MHz) | Pass / Fail |
|---------|-----------------|--------------------------|-------------|
| 1 | 2412 | 16.92 | Pass |
| 6 | 2437 | 17.04 | Pass |
| 11 | 2462 | 17.04 | Pass |

802.11n (HT20)

| Channel | Frequency (MHz) | Occupied Bandwidth (MHz) | Pass / Fail |
|---------|-----------------|--------------------------|-------------|
| 1 | 2412 | 18.00 | Pass |
| 6 | 2437 | 18.12 | Pass |
| 11 | 2462 | 17.88 | Pass |

Spectrum Plot of Worst Value

802.11b

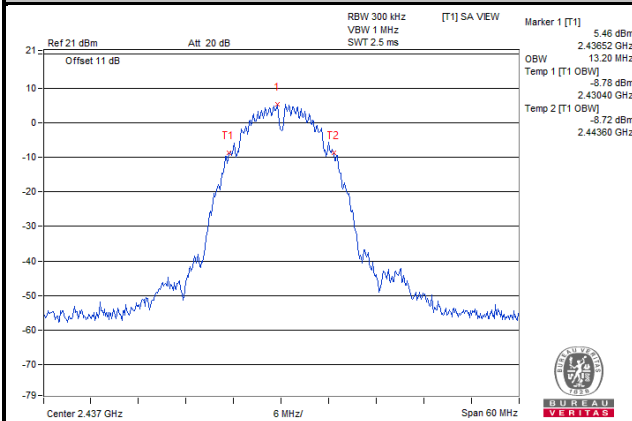

802.11g

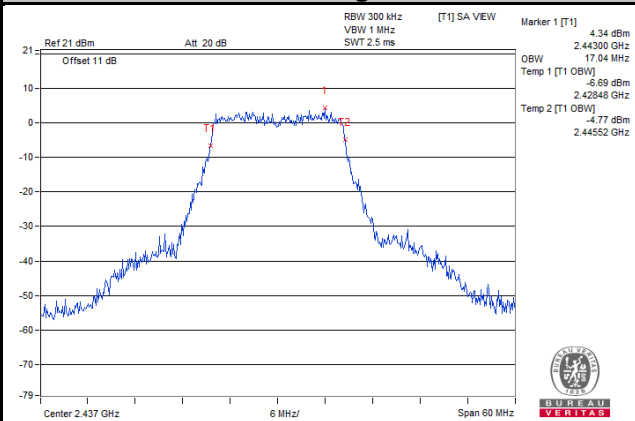

802.11n (HT20)

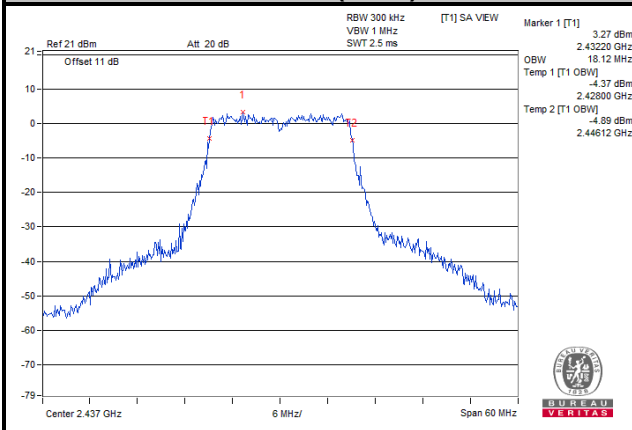

4.5 Conducted Output Power Measurement

4.5.1 Limits of Conducted Output Power Measurement

For systems using digital modulation in the 2400–2483.5 MHz bands: 1 Watt (30 dBm)

4.5.2 Test Setup

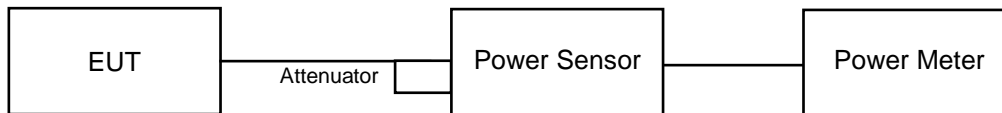

4.5.3 Test Instruments

Refer to section 4.1.2 to get information of above instrument.

4.5.4 Test Procedures

A peak power sensor was used on the output port of the EUT. A power meter was used to read the response of the peak power sensor. Record the power level.

Average power sensor was used to perform output power measurement, trigger and gating function of wide band power meter is enabled to measure max output power of TX on burst. Duty factor is not added to measured value.

4.5.5 Deviation from Test Standard

No deviation.

4.5.6 EUT Operating Conditions

The software provided by client to enable the EUT under transmission condition continuously at lowest, middle and highest channel frequencies individually.

4.5.7 Test Results

Peak Power

802.11b

| Channel | Frequency (MHz) | Peak Power (mW) | Peak Power (dBm) | Limit (dBm) | Pass / Fail |
|---------|-----------------|-----------------|------------------|-------------|-------------|
| 1 | 2412 | 37.931 | 15.79 | 30 | Pass |
| 6 | 2437 | 38.726 | 15.88 | 30 | Pass |
| 11 | 2462 | 38.637 | 15.87 | 30 | Pass |

802.11g

| Channel | Frequency (MHz) | Peak Power (mW) | Peak Power (dBm) | Limit (dBm) | Pass / Fail |
|---------|-----------------|-----------------|------------------|-------------|-------------|
| 1 | 2412 | 104.232 | 20.18 | 30 | Pass |
| 6 | 2437 | 130.918 | 21.17 | 30 | Pass |
| 11 | 2462 | 136.144 | 21.34 | 30 | Pass |

802.11n (HT20)

| Channel | Frequency (MHz) | Peak Power (mW) | Peak Power (dBm) | Limit (dBm) | Pass / Fail |
|---------|-----------------|-----------------|------------------|-------------|-------------|
| 1 | 2412 | 104.472 | 20.19 | 30 | Pass |
| 6 | 2437 | 115.08 | 20.61 | 30 | Pass |
| 11 | 2462 | 138.357 | 21.41 | 30 | Pass |

Average Power

802.11b

| Channel | Frequency (MHz) | Average Power (mW) | Average Power (dBm) | Limit (dBm) | Pass / Fail |
|---------|-----------------|--------------------|---------------------|-------------|-------------|
| 1 | 2412 | 20.845 | 13.19 | 30 | Pass |
| 6 | 2437 | 21.33 | 13.29 | 30 | Pass |
| 11 | 2462 | 21.281 | 13.28 | 30 | Pass |

802.11g

| Channel | Frequency (MHz) | Average Power (mW) | Average Power (dBm) | Limit (dBm) | Pass / Fail |
|---------|-----------------|--------------------|---------------------|-------------|-------------|
| 1 | 2412 | 17.906 | 12.53 | 30 | Pass |
| 6 | 2437 | 16.827 | 12.26 | 30 | Pass |
| 11 | 2462 | 18.03 | 12.56 | 30 | Pass |

802.11n (HT20)

| Channel | Frequency (MHz) | Average Power (mW) | Average Power (dBm) | Limit (dBm) | Pass / Fail |
|---------|-----------------|--------------------|---------------------|-------------|-------------|
| 1 | 2412 | 17.022 | 12.31 | 30 | Pass |
| 6 | 2437 | 17.824 | 12.51 | 30 | Pass |
| 11 | 2462 | 18.239 | 12.61 | 30 | Pass |

4.6 Power Spectral Density Measurement

4.6.1 Limits of Power Spectral Density Measurement

The Maximum of Power Spectral Density Measurement is 8 dBm in any 3 kHz band during any time interval of continuous transmission.

4.6.2 Test Setup

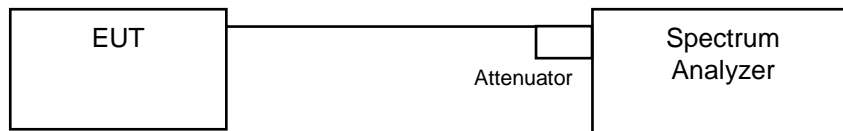

4.6.3 Test Instruments

Refer to section 4.1.2 to get information of above instrument.

4.6.4 Test Procedure

- a. Set analyzer center frequency to DTS channel center frequency.
- b. Set the span to 1.5 times the DTS bandwidth.
- c. Set the RBW to: $3 \text{ kHz} \leq \text{RBW} \leq 100 \text{ kHz}$.
- d. Set the VBW $\geq 3 \times \text{RBW}$.
- e. Detector = peak.
- f. Sweep time = auto couple.
- g. Trace mode = max hold.
- h. Allow trace to fully stabilize.
- i. Use the peak marker function to determine the maximum amplitude level within the RBW.

4.6.5 Deviation from Test Standard

No deviation.

4.6.6 EUT Operating Condition

The software provided by client to enable the EUT under transmission condition continuously at lowest, middle and highest channel frequencies individually.

4.6.7 Test Results

802.11b

| Channel | Frequency (MHz) | PSD (dBm/3 kHz) | Limit (dBm/3 kHz) | Pass / Fail |
|---------|-----------------|-----------------|-------------------|-------------|
| 1 | 2412 | -8.62 | 8 | Pass |
| 6 | 2437 | -9.86 | 8 | Pass |
| 11 | 2462 | -10.34 | 8 | Pass |

802.11g

| Channel | Frequency (MHz) | PSD (dBm/3 kHz) | Limit (dBm/3 kHz) | Pass / Fail |
|---------|-----------------|-----------------|-------------------|-------------|
| 1 | 2412 | -14.04 | 8 | Pass |
| 6 | 2437 | -14.05 | 8 | Pass |
| 11 | 2462 | -13.88 | 8 | Pass |

802.11n (HT20)

| Channel | Frequency (MHz) | PSD (dBm/3 kHz) | Limit (dBm/3 kHz) | Pass / Fail |
|---------|-----------------|-----------------|-------------------|-------------|
| 1 | 2412 | -13.86 | 8 | Pass |
| 6 | 2437 | -13.96 | 8 | Pass |
| 11 | 2462 | -13.01 | 8 | Pass |

Spectrum Plot of Worst Value

802.11b

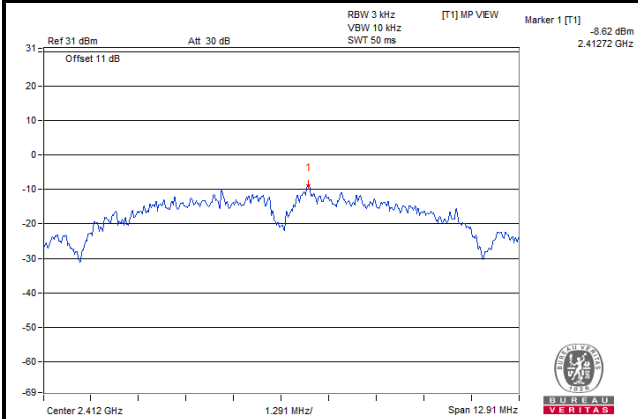

802.11g

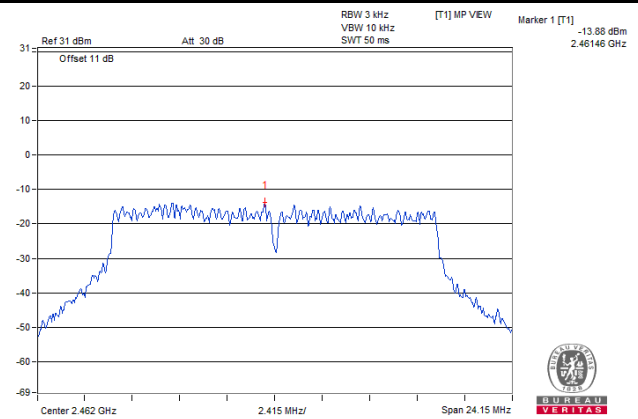

802.11n (HT20)

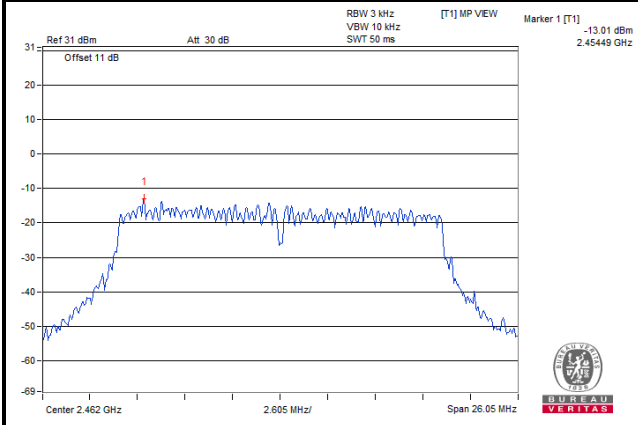

4.7 Conducted Out of Band Emission Measurement

4.7.1 Limits of Conducted Out of Band Emission Measurement

Below -20 dB of the highest emission level of operating band (in 100 kHz Resolution Bandwidth).

4.7.2 Test Setup

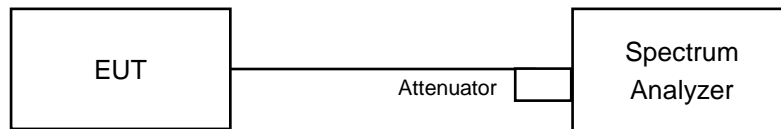

4.7.3 Test Instruments

Refer to section 4.1.2 to get information of above instrument.

4.7.4 Test Procedure

MEASUREMENT PROCEDURE REF

1. Set the RBW = 100 kHz.
2. Set the VBW \geq 300 kHz.
3. Detector = peak.
4. Sweep time = auto couple.
5. Trace mode = max hold.
6. Allow trace to fully stabilize.
7. Use the peak marker function to determine the maximum power level in any 100 kHz band segment within the fundamental EBW.

MEASUREMENT PROCEDURE OOB

1. Set RBW = 100 kHz.
2. Set VBW \geq 300 kHz.
3. Detector = peak.
4. Sweep = auto couple.
5. Trace Mode = max hold.
6. Allow trace to fully stabilize.
7. Use the peak marker function to determine the maximum amplitude level.

4.7.5 Deviation from Test Standard

No deviation.

4.7.6 EUT Operating Condition

The software provided by client to enable the EUT under transmission condition continuously at lowest, middle and highest channel frequencies individually.

4.7.7 Test Results

The spectrum plots are attached on the following images. D1 line indicates the highest level, and D2 line indicates the 20 dB offset below D1. It shows compliance with the requirement.

802.11b

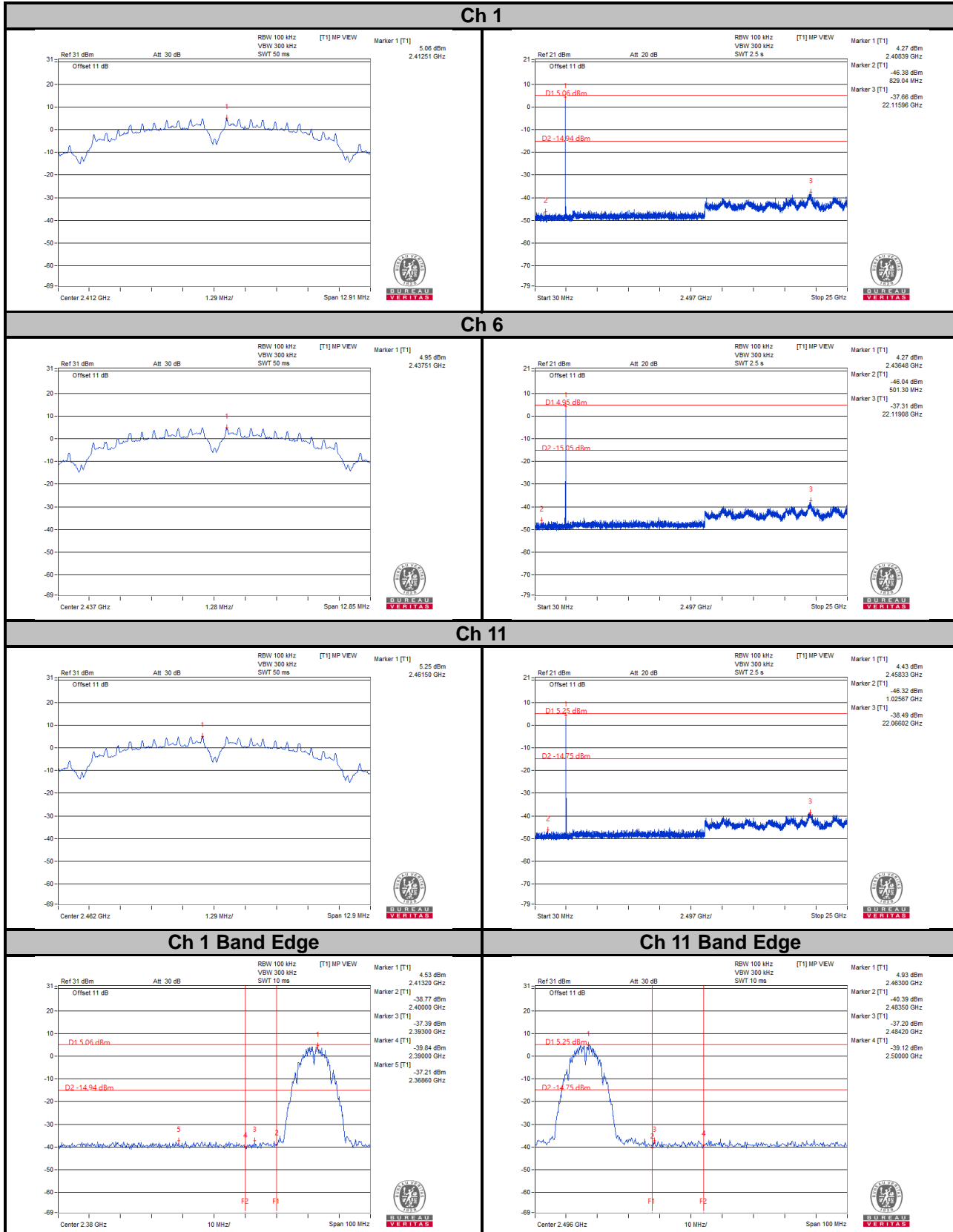

802.11g

Ch 1

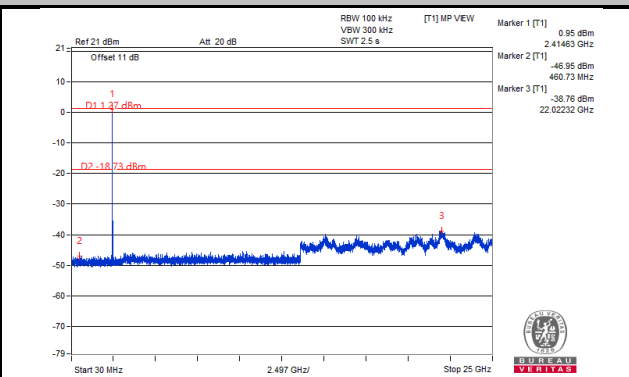
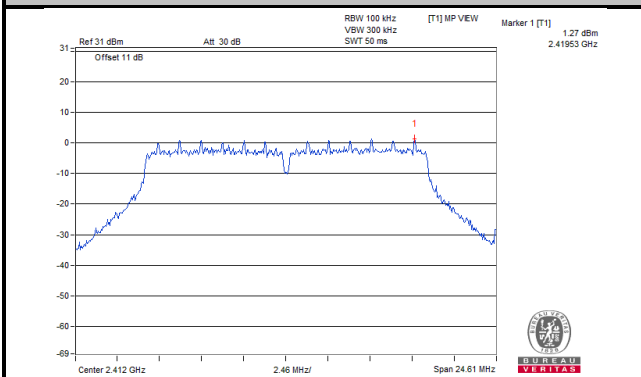

Ch 6

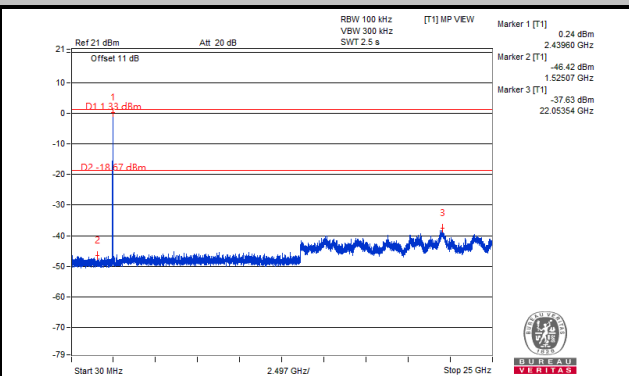
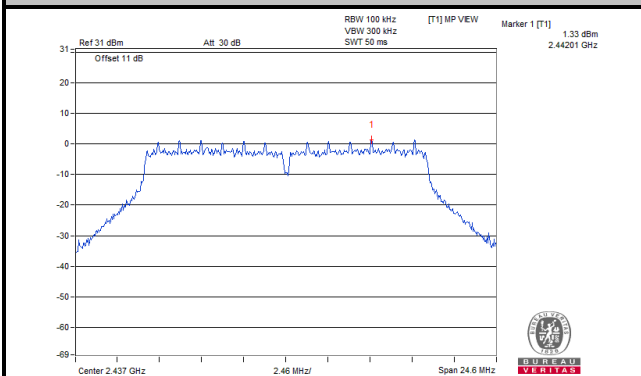

Ch 11

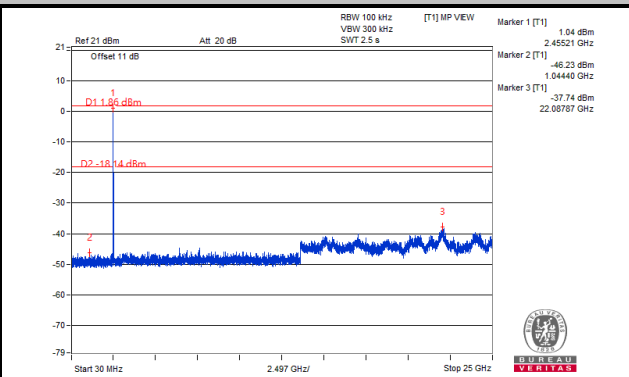
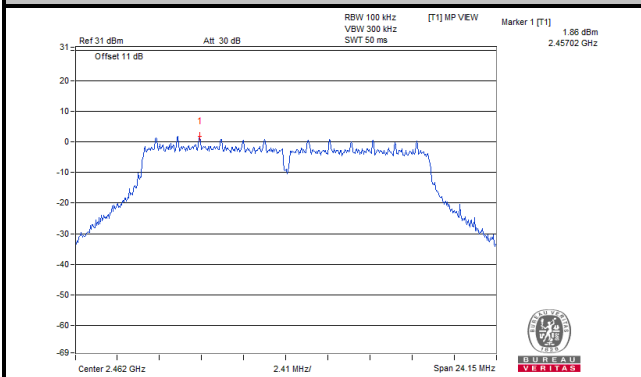

Ch 1 Band Edge

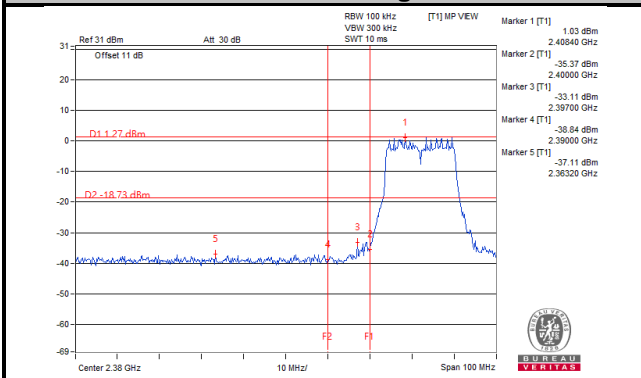

Ch 11 Band Edge

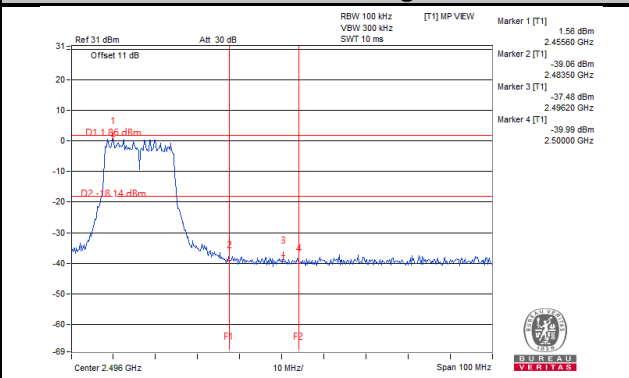

802.11n (HT20)

Ch 1

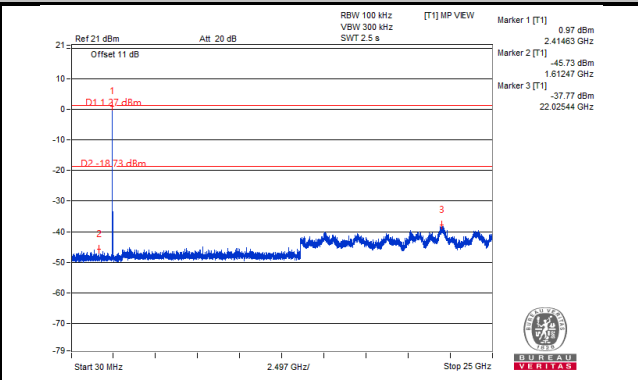
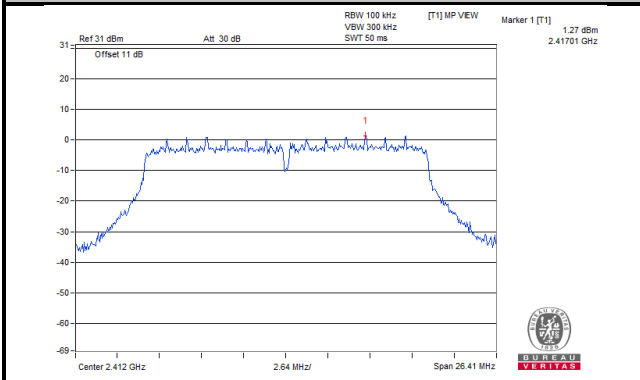

Ch 6

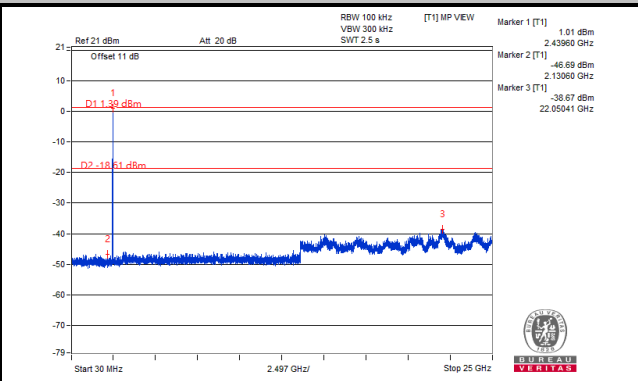
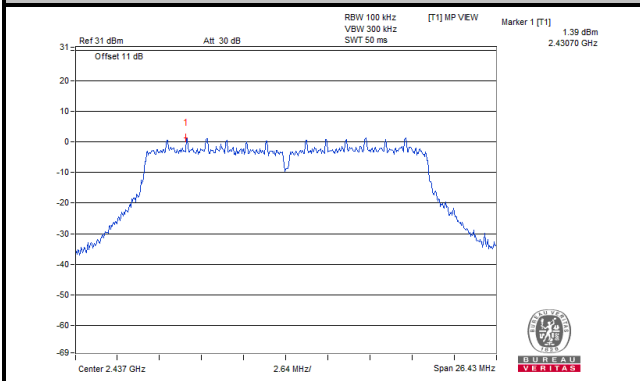

Ch 11

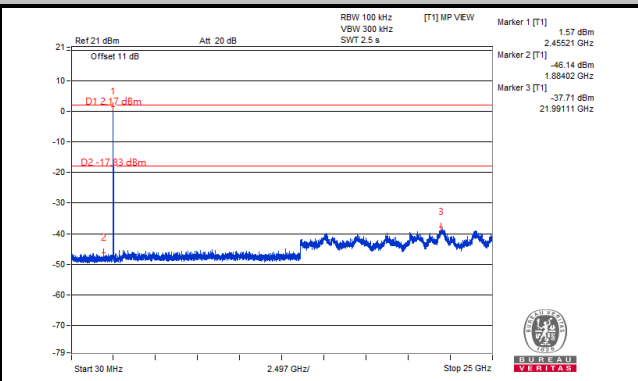
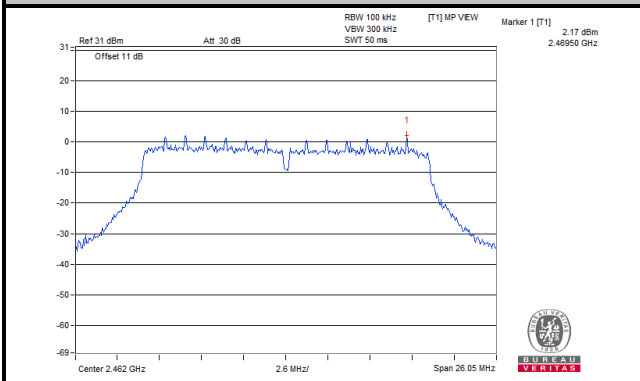

Ch 1 Band Edge

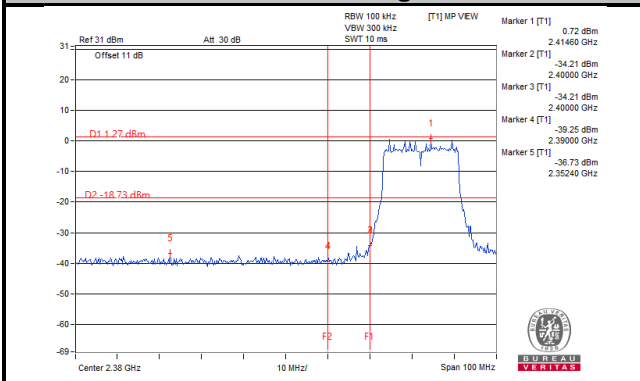

Ch 11 Band Edge

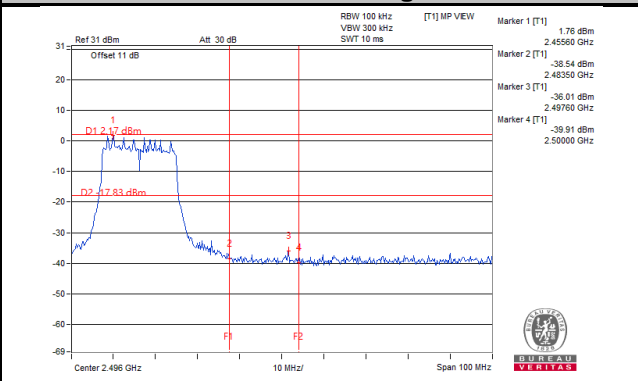

5 Pictures of Test Arrangements

Please refer to the attached file (Test Setup Photo).

Annex A – Band Edge Measurement

802.11b

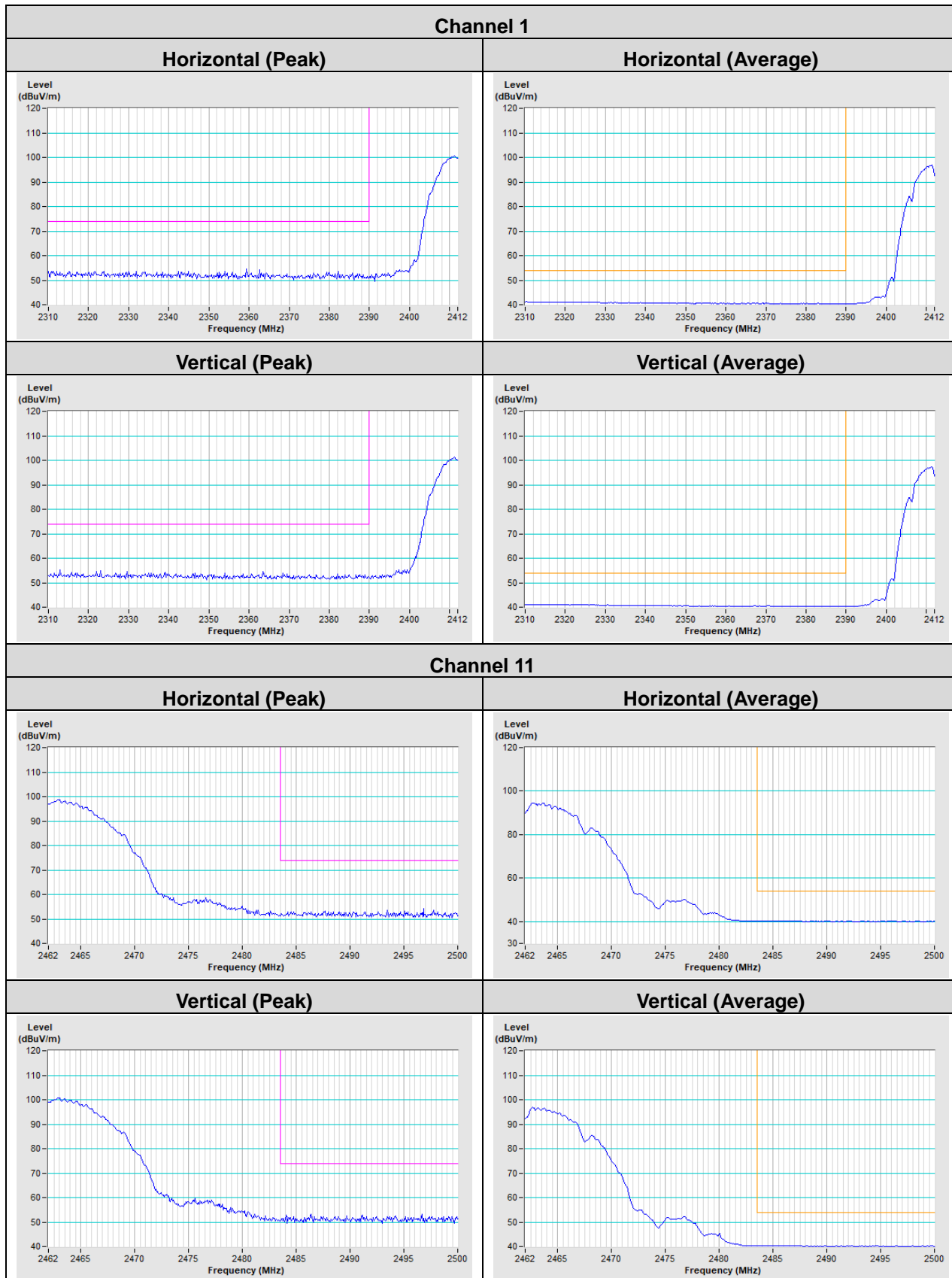

802.11g

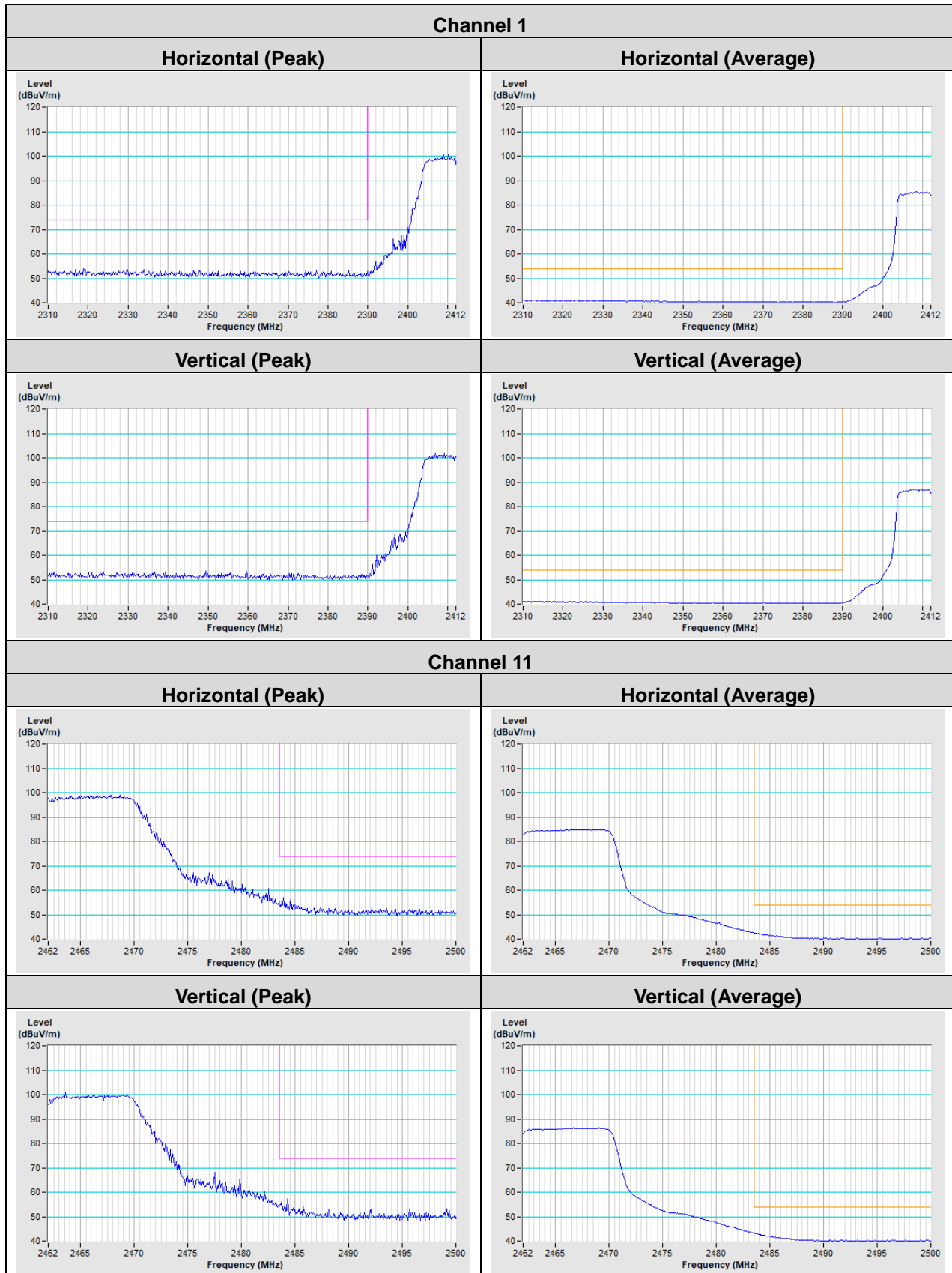

802.11n (HT20)

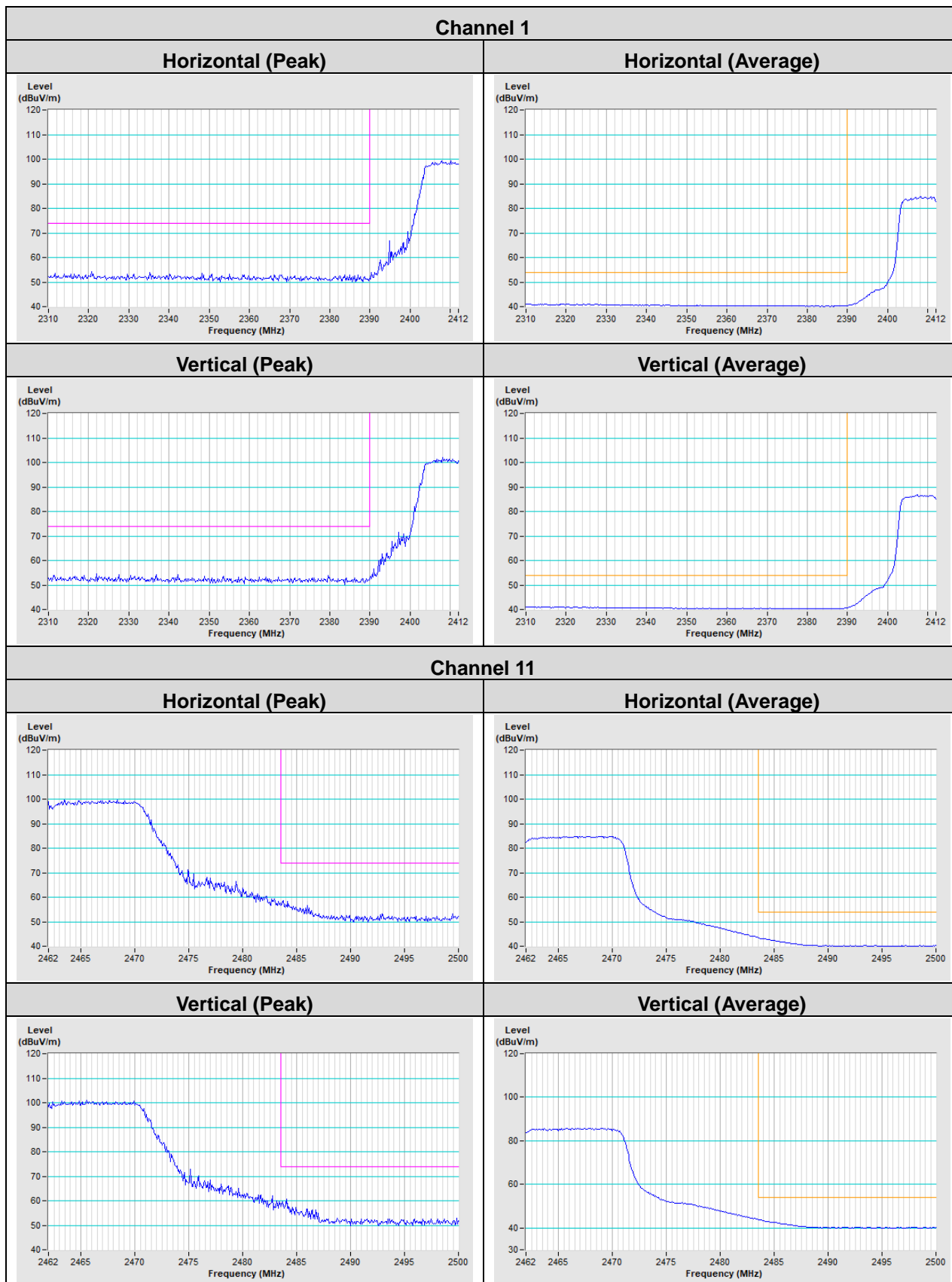

Appendix – Information of the Testing Laboratories

We, Bureau Veritas Consumer Products Services (H.K.) Ltd., Taoyuan Branch, were founded in 1988 to provide our best service in EMC, Radio, Telecom and Safety consultation. Our laboratories are FCC recognized accredited test firms and accredited according to ISO/IEC 17025.

If you have any comments, please feel free to contact us at the following:

Lin Kou EMC/RF Lab

Tel: 886-2-26052180

Fax: 886-2-26051924

Hsin Chu EMC/RF/Telecom Lab

Tel: 886-3-6668565

Fax: 886-3-6668323

Hwa Ya EMC/RF/Safety Lab

Tel: 886-3-3183232

Fax: 886-3-3270892

Email: service.adt@tw.bureauveritas.com

Web Site: www.bureauveritas-adt.com

The address and road map of all our labs can be found in our web site also.

--- END ---