

# TEST REPORT

## CERTIFICATE OF CONFORMITY

**Standard:** 47 CFR FCC Part 22  
47 CFR FCC Part 24  
47 CFR FCC Part 27  
47 CFR FCC Part 90  
47 CFR FCC Part 2

**Report No.:** RFBCUN-WTW-P23110013-1

**FCC ID:** H8NNCM1120

**Product:** AT&T Internet Air™ for Business 5G Gateway

**Brand:** AT&T

**Model No.:** NCM1120D2-D323

**Received Date:** 2023/11/1

**Test Date:** 2023/11/7 ~ 2023/12/13

**Issued Date:** 2024/1/29

**Applicant:** ASKEY COMPUTER CORP.

**Address:** 10F, No.119, Jiankang Rd., Zhonghe Dist., New Taipei City, Taiwan

**Issued By:** Bureau Veritas Consumer Products Services (H.K.) Ltd., Taoyuan Branch  
Lin Kou Laboratories

**Lab Address:** No. 47-2, 14th Ling, Chia Pau Vil., Lin Kou Dist., New Taipei City, Taiwan

**Test Location:** No. 19, Hwa Ya 2nd Rd., Wen Hwa Vil., Kewi Shan Dist., Taoyuan City 33383, Taiwan

### FCC Registration /

**Designation Number:** 788550 / TW0003

**Approved by:** \_\_\_\_\_

*Jeremy Lin*

**Date:** \_\_\_\_\_

**2024/1/29**

Jeremy Lin / Project Engineer

This test report consists of 417 pages in total. It may be duplicated completely for legal use with the approval of the applicant. It should not be reproduced except in full, without the written approval of our laboratory. The test results in the report only apply to the tested sample. The test results in this report are traceable to the national or international standards.

Prepared by : Pettie Chen / Senior Specialist



This report is governed by, and incorporates by reference, the Conditions of Testing as posted at the date of issuance of this report at <http://www.bureauveritas.com/home/about-us/our-business/cps/about-us/terms-conditions/> and is intended for your exclusive use. Any copying or replication of this report to or for any other person or entity, or use of our name or trademark, is permitted only with our prior written permission. This report sets forth our findings solely with respect to the test samples identified herein. The results set forth in this report are not indicative or representative of the quality or characteristics of the lot from which a test sample was taken or any similar or identical product unless specifically and expressly noted. Our report includes all of the tests requested by you and the results thereof based upon the information that you provided to us. Measurement uncertainty is only provided upon request for accredited tests. Statements of conformity are based on simple acceptance criteria without taking measurement uncertainty into account, unless otherwise requested in writing. You have 60 days from date of issuance of this report to notify us of any material error or omission caused by our negligence or if you require measurement uncertainty; provided, however, that such notice shall be in writing and shall specifically address the issue you wish to raise. A failure to raise such issue within the prescribed time shall constitute your unqualified acceptance of the completeness of this report, the tests conducted and the correctness of the report contents.

## Table of Contents

<b>Release Control Record</b> .....	<b>5</b>
<b>1 Certificate</b> .....	<b>6</b>
<b>2 Summary of Test Results</b> .....	<b>7</b>
2.1 Measurement Uncertainty .....	8
2.2 Supplementary Information .....	8
<b>3 General Information</b> .....	<b>9</b>
3.1 General Description of EUT .....	9
3.2 Antenna Description of EUT .....	13
3.3 Test Mode Applicability and Tested Channel Detail .....	15
3.4 Test Program Used and Operation Descriptions .....	29
3.5 Connection Diagram of EUT and Peripheral Devices .....	29
3.6 Configuration of Peripheral Devices and Cable Connections .....	30
<b>4 Test Instruments</b> .....	<b>31</b>
4.1 Effective Radiated Power and Equivalent Isotropically Radiated Power .....	31
4.2 Modulation Characteristics .....	32
4.3 Peak to Average Ratio .....	32
4.4 Bandwidth .....	32
4.5 Conducted Spurious Emissions .....	32
4.6 Radiated Spurious Emissions below 1GHz .....	33
4.7 Radiated Spurious Emissions above 1GHz .....	34
4.8 Frequency Stability .....	35
<b>5 Limits of Test Items</b> .....	<b>36</b>
5.1 Effective Radiated Power and Equivalent Isotropically Radiated Power .....	36
5.2 Modulation Characteristics .....	36
5.3 Peak to Average Ratio .....	36
5.4 Bandwidth .....	36
5.5 Conducted Spurious Emissions .....	37
5.6 Radiated Spurious Emissions below 1GHz .....	38
5.7 Radiated Spurious Emissions above 1GHz .....	39
5.8 Frequency Stability .....	39
<b>6 Test Arrangements</b> .....	<b>40</b>
6.1 Effective Radiated Power and Equivalent Isotropically Radiated Power .....	40
6.1.1 Test Setup .....	40
6.1.2 Test Procedure .....	40
6.2 Modulation Characteristics .....	41
6.2.1 Test Setup .....	41
6.2.2 Test Procedure .....	41
6.3 Peak to Average Ratio .....	41
6.3.1 Test Setup .....	41
6.3.2 Test Procedure .....	41
6.4 Bandwidth .....	42
6.4.1 Test Setup .....	42
6.4.2 Test Procedure .....	42
6.5 Conducted Spurious Emissions .....	44
6.5.1 Test Setup .....	44
6.5.2 Test Procedure .....	44
6.6 Radiated Spurious Emissions below 1GHz .....	45
6.6.1 Test Setup .....	45
6.6.2 Test Procedure .....	45
6.7 Radiated Spurious Emissions above 1GHz .....	46
6.7.1 Test Setup .....	46
6.7.2 Test Procedure .....	46
6.8 Frequency Stability .....	47
6.8.1 Test Setup .....	47



6.8.2	Test Procedure.....	47
<b>7</b>	<b>Test Results of Test Item.....</b>	<b>48</b>
7.1	Effective Radiated Power and Equivalent Isotropically Radiated Power.....	48
	<b>Mode A</b> .....	48
7.1.1	LTE Band 2.....	48
7.1.2	LTE Band 4.....	60
7.1.3	LTE Band 5.....	72
7.1.4	LTE Band 12.....	80
7.1.5	LTE Band 14.....	88
7.1.6	LTE Band 30.....	92
7.1.7	LTE Band 66.....	96
	<b>Mode B</b> .....	108
7.1.8	LTE Band 2.....	108
7.1.9	LTE Band 4.....	120
7.1.10	LTE Band 30.....	132
7.1.11	LTE Band 66.....	136
7.2	Modulation Characteristics.....	148
7.2.1	LTE Band 2.....	148
7.2.2	LTE Band 4.....	149
7.2.3	LTE Band 5.....	150
7.2.4	LTE Band 12.....	151
7.2.5	LTE Band 14.....	152
7.2.6	LTE Band 30.....	153
7.2.7	LTE Band 66.....	154
7.3	Peak to Average Ratio.....	155
7.3.1	LTE Band 2.....	155
7.3.2	LTE Band 4.....	161
7.3.3	LTE Band 5.....	167
7.3.4	LTE Band 12.....	171
7.3.5	LTE Band 14.....	175
7.3.6	LTE Band 30.....	177
7.3.7	LTE Band 66.....	179
7.4	Bandwidth.....	185
7.4.1	LTE Band 2.....	185
7.4.2	LTE Band 4.....	191
7.4.3	LTE Band 5.....	197
7.4.4	LTE Band 12.....	201
7.4.5	LTE Band 14.....	205
7.4.6	LTE Band 30.....	207
7.4.7	LTE Band 66.....	209
7.5	Conducted Spurious Emissions.....	215
7.5.1	LTE Band 2.....	215
7.5.2	LTE Band 4.....	227
7.5.3	LTE Band 5.....	239
7.5.4	LTE Band 12.....	247
7.5.5	LTE Band 14.....	255
7.5.6	LTE Band 30.....	261
7.5.7	LTE Band 66.....	268
7.6	Radiated Spurious Emissions below 1GHz.....	280
	<b>Mode A</b> .....	280
7.6.1	LTE Band 2.....	280
7.6.2	LTE Band 4.....	282
7.6.3	LTE Band 5.....	284
7.6.4	LTE Band 12.....	286
7.6.5	LTE Band 14.....	288
7.6.6	LTE Band 30.....	290
7.6.7	LTE Band 66.....	292
	<b>Mode B</b> .....	294
7.6.8	LTE Band 2.....	294
7.6.9	LTE Band 4.....	296



7.6.10	LTE Band 30 .....	298
7.6.11	LTE Band 66 .....	300
7.7	Radiated Spurious Emissions above 1GHz .....	302
<b>Mode A</b>	.....	<b>302</b>
7.7.1	LTE Band 2 .....	302
7.7.2	LTE Band 4 .....	311
7.7.3	LTE Band 5 .....	320
7.7.4	LTE Band 12 .....	329
7.7.5	LTE Band 14 .....	338
7.7.6	LTE Band 30 .....	342
7.7.7	LTE Band 66 .....	346
<b>Mode B</b>	.....	<b>355</b>
7.7.8	LTE Band 2 .....	355
7.7.9	LTE Band 4 .....	364
7.7.10	LTE Band 30 .....	373
7.7.11	LTE Band 66 .....	377
7.8	Frequency Stability .....	386
7.8.1	LTE Band 2 .....	386
7.8.2	LTE Band 4 .....	392
7.8.3	LTE Band 5 .....	398
7.8.4	LTE Band 12 .....	402
7.8.5	LTE Band 14 .....	406
7.8.6	LTE Band 30 .....	408
7.8.7	LTE Band 66 .....	410
<b>8</b>	<b>Pictures of Test Arrangements .....</b>	<b>416</b>
<b>9</b>	<b>Information of the Testing Laboratories .....</b>	<b>417</b>



## Release Control Record

Issue No.	Description	Date Issued
RFBCUN-WTW-P23110013-1	Original release.	2024/1/29

## 1 Certificate

**Product:** AT&T Internet Air™ for Business 5G Gateway

**Brand:** AT&T

**Test Model:** NCM1120D2-D323

**Sample Status:** Engineering sample

**Applicant:** ASKEY COMPUTER CORP.

**Test Date:** 2023/11/7 ~ 2023/12/13

**Standard:** 47 CFR FCC Part 22  
47 CFR FCC Part 24  
47 CFR FCC Part 27  
47 CFR FCC Part 90  
47 CFR FCC Part 2

**Measurement** ANSI/TIA/EIA-603-E 2016

**procedure:** ANSI C63.26-2015

KDB 971168 D01 Power Meas License Digital Systems v03r01

KDB 971168 D02 Misc Rev Approv License Devices v02r02

The above equipment has been tested by **Bureau Veritas Consumer Products Services (H.K.) Ltd., Taoyuan Branch**, and found compliance with the requirement of the above standards. The test record, data evaluation & Equipment Under Test (EUT) configurations represented herein are true and accurate accounts of the measurements of the sample's RF characteristics under the conditions specified in this report.

## 2 Summary of Test Results

Standard / Clause	Test Item	Result	Remark
Part 2.1046 Part 22.913(a) Part 24.232(c) Part 27.50(d) Part 27.50(c) Part 27.50(a) Part 90.542(a)(7)	Effective Radiated Power and Equivalent Isotropically Radiated Power	Pass	Meet the requirement of limit.
Part 2.1047	Modulation Characteristics	Pass	Meet the requirement of limit.
Part 22.913(d) Part 24.232(d) Part 27.50(d)	Peak to Average Ratio	Pass	Meet the requirement of limit.
Part 2.1049	Bandwidth	Pass	Meet the requirement of limit.
Part 2.1051 Part 22.917 Part 24.238 Part 27.53(h) Part 27.53(g) Part 27.53(a) Part 90.543(e)(f)	Conducted Spurious Emissions	Pass	Meet the requirement of limit.
Part 2.1053 Part 22.917 Part 24.238 Part 27.53(h) Part 27.53(g) Part 27.53(a) Part 90.543(e)(f)	Radiated Spurious Emissions below 1GHz	Pass	Minimum passing margin is -1.05 dB at 40.67 MHz
Part 2.1053 Part 22.917 Part 24.238 Part 27.53(h) Part 27.53(g) Part 27.53(a) Part 90.543(e)(f)	Radiated Spurious Emissions above 1GHz	Pass	Minimum passing margin is -8.26 dB at 4620.00 MHz
Part 2.1055 Part 22.355 Part 24.235 Part 27.54 Part 90.539(e)	Frequency Stability	Pass	Meet the requirement of limit.

Note: Determining compliance based on the results of the compliance measurement, not taking into account measurement instrumentation uncertainty.

## 2.1 Measurement Uncertainty

Where relevant, the following measurement uncertainty levels have been estimated for tests performed on the EUT as specified in CISPR 16-4-2:

Parameter	Specification	Uncertainty (±)
Radiated Spurious Emissions below 1GHz	9 kHz ~ 30 MHz	2.44 dB
	30 MHz ~ 1 GHz	2.95 dB
Radiated Spurious Emissions above 1GHz	1 GHz ~ 18 GHz	2.26 dB
	18 GHz ~ 40 GHz	1.94 dB

The other instruments specified are routine verified to remain within the calibrated levels, no measurement uncertainty is required to be calculated.

## 2.2 Supplementary Information

There is not any deviation from the test standards for the test method, and no modifications required for compliance.



### 3 General Information

#### 3.1 General Description of EUT

Product	AT&T Internet Air™ for Business 5G Gateway
Brand	AT&T
Test Model	NCM1120D2-D323
Status of EUT	Engineering sample
Power Supply Rating	12Vdc from adapter
HW Version	REV03
SW Version	NCM1120D2_v240131

Note:

#### 1. EUT Overview

Mode	Bandwidth	TX Frequency Range (MHz)	Modulation	Internal Antenna		Emission Designator
				Max. ERP (W)	Max. ERP (dBm)	
LTE Band 5	1.4 MHz	824.7 ~ 848.3	QPSK	0.1914	22.82	1M09G7D
			16QAM	0.1675	22.24	1M09D7W
			64QAM	0.1256	20.99	1M09D7W
			256QAM	0.0706	18.49	1M09D7W
	3 MHz	825.5 ~ 847.5	QPSK	0.1901	22.79	2M70G7D
			16QAM	0.1581	21.99	2M70D7W
			64QAM	0.1309	21.17	2M70D7W
			256QAM	0.0664	18.22	2M70D7W
	5 MHz	826.5 ~ 846.5	QPSK	0.1936	22.87	4M50G7D
			16QAM	0.1585	22	4M49D7W
			64QAM	0.1236	20.92	4M50D7W
			256QAM	0.0711	18.52	4M49D7W
	10 MHz	829 ~ 844	QPSK	0.1977	22.96	8M99G7D
			16QAM	0.1641	22.15	8M99D7W
			64QAM	0.1294	21.12	8M99D7W
			256QAM	0.0695	18.42	8M98D7W
LTE Band 12	1.4 MHz	699.7 ~ 715.3	QPSK	0.1972	22.95	1M09G7D
			16QAM	0.1618	22.09	1M09D7W
			64QAM	0.1327	21.23	1M09D7W
			256QAM	0.0718	18.56	1M09D7W
	3 MHz	700.5 ~ 714.5	QPSK	0.1905	22.8	2M70G7D
			16QAM	0.1807	22.57	2M70D7W
			64QAM	0.1306	21.16	2M70D7W
			256QAM	0.0662	18.21	2M70D7W
	5 MHz	701.5 ~ 713.5	QPSK	0.1968	22.94	4M50G7D
			16QAM	0.1786	22.52	4M49D7W
			64QAM	0.1371	21.37	4M50D7W
			256QAM	0.0745	18.72	4M49D7W
	10 MHz	704 ~ 711	QPSK	0.1995	23	9M03G7D
			16QAM	0.1742	22.41	9M03D7W
			64QAM	0.1343	21.28	9M03D7W
			256QAM	0.0708	18.5	9M02D7W

Mode	Bandwidth	TX Frequency Range (MHz)	Modulation	Internal Antenna		Emission Designator
				Max. ERP (W)	Max. ERP (dBm)	
LTE Band 14	5 MHz	790.5 ~ 795.5	QPSK	0.1959	22.92	4M51G7D
			16QAM	0.1679	22.25	4M51D7W
			64QAM	0.1309	21.17	4M50D7W
			256QAM	0.0750	18.75	4M49D7W
	10 MHz	793	QPSK	0.1977	22.96	9M00G7D
			16QAM	0.1758	22.45	9M00D7W
			64QAM	0.1274	21.05	9M00D7W
			256QAM	0.0731	18.64	8M99D7W

Mode	Bandwidth	TX Frequency Range (MHz)	Modulation	Internal Antenna		External Antenna		Emission Designator
				Max. EIRP (W)	Max. EIRP (dBm)	Max. EIRP (W)	Max. EIRP (dBm)	
LTE Band 2	1.4 MHz	1850.7 ~ 1909.3	QPSK	0.3055	24.85	0.4027	26.05	1M09G7D
			16QAM	0.2600	24.15	0.3373	25.28	1M09D7W
			64QAM	0.2037	23.09	0.2655	24.24	1M09D7W
			256QAM	0.1005	20.02	0.1297	21.13	1M09D7W
	3 MHz	1851.5 ~ 1908.5	QPSK	0.2992	24.76	0.3981	26	2M70G7D
			16QAM	0.2692	24.3	0.3565	25.52	2M70D7W
			64QAM	0.2009	23.03	0.2618	24.18	2M70D7W
			256QAM	0.1038	20.16	0.1380	21.4	2M70D7W
	5 MHz	1852.5 ~ 1907.5	QPSK	0.3055	24.85	0.4018	26.04	4M50G7D
			16QAM	0.2748	24.39	0.3597	25.56	4M49D7W
			64QAM	0.2000	23.01	0.2624	24.19	4M50D7W
			256QAM	0.1007	20.03	0.1330	21.24	4M49D7W
	10 MHz	1855 ~ 1905	QPSK	0.3083	24.89	0.4074	26.1	8M98G7D
			16QAM	0.2871	24.58	0.3758	25.75	8M98D7W
			64QAM	0.2004	23.02	0.2594	24.14	8M98D7W
			256QAM	0.1012	20.05	0.1334	21.25	8M97D7W
	15 MHz	1857.5 ~ 1902.5	QPSK	0.3013	24.79	0.4009	26.03	13M5G7D
			16QAM	0.2891	24.61	0.3819	25.82	13M5D7W
			64QAM	0.2084	23.19	0.2735	24.37	13M5D7W
			256QAM	0.1047	20.2	0.1358	21.33	13M5D7W
	20 MHz	1860 ~ 1900	QPSK	0.3105	24.92	0.4046	26.07	18M0G7D
			16QAM	0.2735	24.37	0.3614	25.58	18M0D7W
			64QAM	0.2094	23.21	0.2761	24.41	18M0D7W
			256QAM	0.0993	19.97	0.1309	21.17	18M0D7W

Mode	Bandwidth	TX Frequency Range (MHz)	Modulation	Internal Antenna		External Antenna		Emission Designator
				Max. EIRP (W)	Max. EIRP (dBm)	Max. EIRP (W)	Max. EIRP (dBm)	
LTE Band 4	1.4 MHz	1710.7 ~ 1754.3	QPSK	0.3090	24.9	0.4036	26.06	1M09G7D
			16QAM	0.2805	24.48	0.3690	25.67	1M09D7W
			64QAM	0.2023	23.06	0.2673	24.27	1M09D7W
			256QAM	0.0993	19.97	0.1312	21.18	1M09D7W
	3 MHz	1711.5 ~ 1753.5	QPSK	0.2992	24.76	0.3936	25.95	2M70G7D
			16QAM	0.2606	24.16	0.3404	25.32	2M70D7W
			64QAM	0.2056	23.13	0.2655	24.24	2M70D7W
			256QAM	0.1040	20.17	0.1374	21.38	2M70D7W
	5 MHz	1712.5 ~ 1752.5	QPSK	0.3034	24.82	0.4027	26.05	4M50G7D
			16QAM	0.2773	24.43	0.3664	25.64	4M49D7W
			64QAM	0.2118	23.26	0.2767	24.42	4M50D7W
			256QAM	0.1042	20.18	0.1387	21.42	4M49D7W
	10 MHz	1715 ~ 1750	QPSK	0.3041	24.83	0.3990	26.01	8M99G7D
			16QAM	0.2692	24.3	0.3532	25.48	8M99D7W
			64QAM	0.2070	23.16	0.2729	24.36	8M99D7W
			256QAM	0.1096	20.4	0.1442	21.59	8M98D7W
	15 MHz	1717.5 ~ 1747.5	QPSK	0.3069	24.87	0.4027	26.05	13M5G7D
			16QAM	0.2661	24.25	0.3499	25.44	13M5D7W
			64QAM	0.2023	23.06	0.2679	24.28	13M5D7W
			256QAM	0.1028	20.12	0.1365	21.35	13M5D7W
20 MHz	1720 ~ 1745	QPSK	0.3170	25.01	0.4198	26.23	18M0G7D	
		16QAM	0.2767	24.42	0.3681	25.66	18M0D7W	
		64QAM	0.2051	23.12	0.2685	24.29	18M0D7W	
		256QAM	0.1038	20.16	0.1352	21.31	18M0D7W	
LTE Band 30	5 MHz	2307.5 ~ 2312.5	QPSK	0.2992	24.76	0.4375	26.41	4M50G7D
			16QAM	0.2576	24.11	0.3855	25.86	4M49D7W
			64QAM	0.2023	23.06	0.2965	24.72	4M50D7W
			256QAM	0.1038	20.16	0.1531	21.85	4M49D7W
	10 MHz	2310	QPSK	0.3027	24.81	0.4457	26.49	8M98G7D
			16QAM	0.2618	24.18	0.3819	25.82	8M98D7W
			64QAM	0.1959	22.92	0.2864	24.57	8M98D7W
			256QAM	0.0920	19.64	0.1352	21.31	8M97D7W

Mode	Bandwidth	TX Frequency Range (MHz)	Modulation	Internal Antenna		External Antenna		Emission Designator
				Max. EIRP (W)	Max. EIRP (dBm)	Max. EIRP (W)	Max. EIRP (dBm)	
LTE Band 66	1.4 MHz	1710.7 ~ 1779.3	QPSK	0.3027	24.81	0.3972	25.99	1M09G7D
			16QAM	0.2667	24.26	0.3540	25.49	1M09D7W
			64QAM	0.2028	23.07	0.2679	24.28	1M09D7W
			256QAM	0.1059	20.25	0.1403	21.47	1M09D7W
	3 MHz	1711.5 ~ 1778.5	QPSK	0.2985	24.75	0.3882	25.89	2M70G7D
			16QAM	0.2489	23.96	0.3319	25.21	2M70D7W
			64QAM	0.2032	23.08	0.2710	24.33	2M70D7W
			256QAM	0.0998	19.99	0.1294	21.12	2M70D7W
	5 MHz	1712.5 ~ 1777.5	QPSK	0.3055	24.85	0.4055	26.08	4M49G7D
			16QAM	0.2661	24.25	0.3499	25.44	4M49D7W
			64QAM	0.2004	23.02	0.2655	24.24	4M50D7W
			256QAM	0.1054	20.23	0.1387	21.42	4M49D7W
	10 MHz	1715 ~ 1775	QPSK	0.3027	24.81	0.3926	25.94	8M99G7D
			16QAM	0.2692	24.3	0.3491	25.43	8M99D7W
			64QAM	0.2004	23.02	0.2618	24.18	8M99D7W
			256QAM	0.1042	20.18	0.1355	21.32	8M98D7W
	15 MHz	1717.5 ~ 1772.5	QPSK	0.3055	24.85	0.3936	25.95	13M5G7D
			16QAM	0.2773	24.43	0.3573	25.53	13M5D7W
			64QAM	0.1982	22.97	0.2606	24.16	13M5D7W
			256QAM	0.0998	19.99	0.1327	21.23	13M5D7W
20 MHz	1720 ~ 1770	QPSK	0.3083	24.89	0.4046	26.07	18M0G7D	
		16QAM	0.2767	24.42	0.3639	25.61	18M0D7W	
		64QAM	0.2032	23.08	0.2630	24.2	18M0D7W	
		256QAM	0.1050	20.21	0.1352	21.31	18M0D7W	

2. The EUT uses following accessories.

AC Adapter		
Brand	Model	Specification
MASS POWER	S030-1C120250VU	AC Input power: 100-240V~ 50/60Hz 0.8A DC Output power: 12.0V 2.5A

3. The above EUT information is declared by manufacturer and for more detailed features description, please refers to the manufacturer's specifications or user's manual.

### 3.2 Antenna Description of EUT

1. The antenna information is listed as below.

Internal Antenna					
Antenna Type		PCB			
Antenna Connector		U.FL			
Brand		Antenna company			
Model		Ant. 1: AC31706-01H, Ant. 3: AC31605-01C, Ant. 5: AC31605-01E, Ant. 6: AC31706-01G, Ant. 7: AC31605-01G, Ant. 8: AC31605-01H			
Band	Freq. Range (MHz)	Gain (dBi)			
		Ant. 3	Ant. 5	Ant. 7	Ant. 8
LTE B2	1850 ~ 1910	1	-	-	-
LTE B4	1710 ~ 1755	1	-	-	-
LTE B5	824 ~ 849	-	-	-	0.9
LTE B12	698 ~ 716	-	-	-	0.9
LTE B14	788 ~ 798	-	-	-	0.9
LTE B30	2305 ~ 2315	1	-	-	-
LTE B66	1710 ~ 1780	1	-	-	-
n2	1850 ~ 1910	1	-	-	-
n5	824 ~ 849	-	-	-	0.9
n14	788 ~ 798	-	-	-	0.9
n30	2305 ~ 2315	1	-	-	-
n66	1710 ~ 1780	1	-	-	-
n77	3300 ~ 4200	3	3	-	-

Internal Antenna			
Band	Freq. Range (MHz)	TX & RX Configuration	
LTE B2	1850 ~ 1910	1TX (Ant. 3)	4RX (Ant. 3, 5, 7, 8)
LTE B4	1710 ~ 1755	1TX (Ant. 3)	4RX (Ant. 3, 5, 7, 8)
LTE B5	824 ~ 849	1TX (Ant. 8)	4RX (Ant. 3, 5, 7, 8)
LTE B12	698 ~ 716	1TX (Ant. 8)	4RX (Ant. 3, 5, 7, 8)
LTE B14	788 ~ 798	1TX (Ant. 8)	4RX (Ant. 3, 5, 7, 8)
LTE B30	2305 ~ 2315	1TX (Ant. 3)	4RX (Ant. 3, 5, 7, 8)
LTE B66	1710 ~ 1780	1TX (Ant. 3)	4RX (Ant. 3, 5, 7, 8)
n2	1850 ~ 1910	1TX (Ant. 3)	4RX (Ant. 3, 5, 7, 8)
n5	824 ~ 849	1TX (Ant. 8)	4RX (Ant. 3, 5, 7, 8)
n14	788 ~ 798	1TX (Ant. 8)	4RX (Ant. 3, 5, 7, 8)
n30	2305 ~ 2315	1TX (Ant. 3)	4RX (Ant. 3, 5, 7, 8)
n66	1710 ~ 1780	1TX (Ant. 3)	4RX (Ant. 3, 5, 7, 8)
n77	3300 ~ 4200	2TX (Ant. 3 & Ant. 5)	4RX (Ant. 1, 3, 5, 6)

External Antenna			
Antenna Type		Omni-directional	
Antenna Connector		SMA	
Brand		Parsec Technologies, Inc.	
Model		PRO2CW 2L	
Band	Freq. Range (MHz)	Gain (dBi)	
		Ant. 3	Ant. 5
LTE B2	1850 ~ 1910	3.5	-
LTE B4	1710 ~ 1755	3.5	-
LTE B30	2305 ~ 2315	4	-
LTE B66	1710 ~ 1780	3.5	-
n2	1850 ~ 1910	3.5	-
n30	2305 ~ 2315	4	-
n66	1710 ~ 1780	3.5	-
n77	3300 ~ 4200	4.5	4.5

External Antenna			
Band	Freq. Range (MHz)	TX & RX Configuration	
		LTE B2	1850 ~ 1910
LTE B4	1710 ~ 1755	1TX (Ant. 3)	1RX (Ant. 3)
LTE B30	2305 ~ 2315	1TX (Ant. 3)	1RX (Ant. 3)
LTE B66	1710 ~ 1780	1TX (Ant. 3)	1RX (Ant. 3)
n2	1850 ~ 1910	1TX (Ant. 3)	1RX (Ant. 3)
n30	2305 ~ 2315	1TX (Ant. 3)	1RX (Ant. 3)
n66	1710 ~ 1780	1TX (Ant. 3)	1RX (Ant. 3)
n77	3300 ~ 4200	2TX (Ant. 3, 5)	2RX (Ant. 3, 5)

\*The above Antenna information is declared by manufacturer and for more detailed features description, please refer to the manufacturer's specifications, the laboratory shall not be held responsible.

### 3.3 Test Mode Applicability and Tested Channel Detail

Pre-Scan:	The EUT is designed to be positioned on the Z-axis only. External antenna is designed to be positioned on the Y-axis only.
-----------	--

EUT Configure Mode	Description
A	EUT with internal antenna
B	EUT with external antenna

#### For LTE Band 2

Test Item	EUT Configure Mode	Tested Channel	Channel Bandwidth	Modulation	Mode
EIRP	A, B	18607 (1850.70 MHz) 18900 (1880.00 MHz) 19193 (1909.30 MHz)	1.4 MHz	QPSK / 16QAM / 64QAM / 256QAM	1 RB Half RB Full RB
	A, B	18615 (1851.50 MHz) 18900 (1880.00 MHz) 19185 (1908.50 MHz)	3 MHz	QPSK / 16QAM / 64QAM / 256QAM	1 RB Half RB Full RB
	A, B	18625 (1852.50 MHz) 18900 (1880.00 MHz) 19175 (1907.50 MHz)	5 MHz	QPSK / 16QAM / 64QAM / 256QAM	1 RB Half RB Full RB
	A, B	18650 (1855.00 MHz) 18900 (1880.00 MHz) 19150 (1905.00 MHz)	10 MHz	QPSK / 16QAM / 64QAM / 256QAM	1 RB Half RB Full RB
	A, B	18675 (1857.50 MHz) 18900 (1880.00 MHz) 19125 (1902.50 MHz)	15 MHz	QPSK / 16QAM / 64QAM / 256QAM	1 RB Half RB Full RB
	A, B	18700 (1860.00 MHz) 18900 (1880.00 MHz) 19100 (1900.00 MHz)	20 MHz	QPSK / 16QAM / 64QAM / 256QAM	1 RB Half RB Full RB
Modulation Characteristics	A	18900 (1880.00 MHz)	20 MHz	QPSK / 16QAM / 64QAM / 256QAM	Full RB
Peak to Average Ratio	A	18607 (1850.70 MHz) 18900 (1880.00 MHz) 19193 (1909.30 MHz)	1.4 MHz	QPSK / 16QAM / 64QAM / 256QAM	1 RB
	A	18615 (1851.50 MHz) 18900 (1880.00 MHz) 19185 (1908.50 MHz)	3 MHz	QPSK / 16QAM / 64QAM / 256QAM	1 RB
	A	18625 (1852.50 MHz) 18900 (1880.00 MHz) 19175 (1907.50 MHz)	5 MHz	QPSK / 16QAM / 64QAM / 256QAM	1 RB
	A	18650 (1855.00 MHz) 18900 (1880.00 MHz) 19150 (1905.00 MHz)	10 MHz	QPSK / 16QAM / 64QAM / 256QAM	1 RB
	A	18675 (1857.50 MHz) 18900 (1880.00 MHz) 19125 (1902.50 MHz)	15 MHz	QPSK / 16QAM / 64QAM / 256QAM	1 RB
	A	18700 (1860.00 MHz) 18900 (1880.00 MHz) 19100 (1900.00 MHz)	20 MHz	QPSK / 16QAM / 64QAM / 256QAM	1 RB

Test Item	EUT Configure Mode	Tested Channel	Channel Bandwidth	Modulation	Mode
Occupied Bandwidth	A	18607 (1850.70 MHz) 18900 (1880.00 MHz) 19193 (1909.30 MHz)	1.4 MHz	QPSK / 16QAM / 64QAM / 256QAM	Full RB
	A	18615 (1851.50 MHz) 18900 (1880.00 MHz) 19185 (1908.50 MHz)	3 MHz	QPSK / 16QAM / 64QAM / 256QAM	Full RB
	A	18625 (1852.50 MHz) 18900 (1880.00 MHz) 19175 (1907.50 MHz)	5 MHz	QPSK / 16QAM / 64QAM / 256QAM	Full RB
	A	18650 (1855.00 MHz) 18900 (1880.00 MHz) 19150 (1905.00 MHz)	10 MHz	QPSK / 16QAM / 64QAM / 256QAM	Full RB
	A	18675 (1857.50 MHz) 18900 (1880.00 MHz) 19125 (1902.50 MHz)	15 MHz	QPSK / 16QAM / 64QAM / 256QAM	Full RB
	A	18700 (1860.00 MHz) 18900 (1880.00 MHz) 19100 (1900.00 MHz)	20 MHz	QPSK / 16QAM / 64QAM / 256QAM	Full RB
Conducted Emission	A	18607 (1850.70 MHz) 18900 (1880.00 MHz) 19193 (1909.30 MHz)	1.4 MHz	QPSK	1 RB Full RB
	A	18615 (1851.50 MHz) 18900 (1880.00 MHz) 19185 (1908.50 MHz)	3 MHz	QPSK	1 RB Full RB
	A	18625 (1852.50 MHz) 18900 (1880.00 MHz) 19175 (1907.50 MHz)	5 MHz	QPSK	1 RB Full RB
	A	18650 (1855.00 MHz) 18900 (1880.00 MHz) 19150 (1905.00 MHz)	10 MHz	QPSK	1 RB Full RB
	A	18675 (1857.50 MHz) 18900 (1880.00 MHz) 19125 (1902.50 MHz)	15 MHz	QPSK	1 RB Full RB
	A	18700 (1860.00 MHz) 18900 (1880.00 MHz) 19100 (1900.00 MHz)	20 MHz	QPSK	1 RB Full RB
Radiated Spurious Emissions below 1GHz	A, B	18900 (1880.00 MHz)	20 MHz	QPSK	1 RB
Radiated Spurious Emissions above 1GHz	A, B	18607 (1850.70 MHz) 18900 (1880.00 MHz) 19193 (1909.30 MHz)	1.4 MHz	QPSK	1 RB
	A, B	18625 (1852.50 MHz) 18900 (1880.00 MHz) 19175 (1907.50 MHz)	5 MHz	QPSK	1 RB
	A, B	18700 (1860.00 MHz) 18900 (1880.00 MHz) 19100 (1900.00 MHz)	20 MHz	QPSK	1 RB



Test Item	EUT Configure Mode	Tested Channel	Channel Bandwidth	Modulation	Mode
Frequency Stability	A	18607 (1850.70 MHz) 19193 (1909.30 MHz)	1.4 MHz	QPSK	Full RB
	A	18615 (1851.50 MHz) 19185 (1908.50 MHz)	3 MHz	QPSK	Full RB
	A	18625 (1852.50 MHz) 19175 (1907.50 MHz)	5 MHz	QPSK	Full RB
	A	18650 (1855.00 MHz) 19150 (1905.00 MHz)	10 MHz	QPSK	Full RB
	A	18675 (1857.50 MHz) 19125 (1902.50 MHz)	15 MHz	QPSK	Full RB
	A	18700 (1860.00 MHz) 19100 (1900.00 MHz)	20 MHz	QPSK	Full RB

For LTE Band 4

Test Item	EUT Configure Mode	Tested Channel	Channel Bandwidth	Modulation	Mode
EIRP	A, B	19957 (1710.70 MHz) 20175 (1732.50 MHz) 20393 (1754.30 MHz)	1.4 MHz	QPSK / 16QAM / 64QAM / 256QAM	1 RB Half RB Full RB
	A, B	19965 (1711.50 MHz) 20175 (1732.50 MHz) 20385 (1753.50 MHz)	3 MHz	QPSK / 16QAM / 64QAM / 256QAM	1 RB Half RB Full RB
	A, B	19975 (1712.50 MHz) 20175 (1732.50 MHz) 20375 (1752.50 MHz)	5 MHz	QPSK / 16QAM / 64QAM / 256QAM	1 RB Half RB Full RB
	A, B	20000 (1715.00 MHz) 20175 (1732.50 MHz) 20350 (1750.00 MHz)	10 MHz	QPSK / 16QAM / 64QAM / 256QAM	1 RB Half RB Full RB
	A, B	20025 (1717.50 MHz) 20175 (1732.50 MHz) 20325 (1747.50 MHz)	15 MHz	QPSK / 16QAM / 64QAM / 256QAM	1 RB Half RB Full RB
	A, B	20050 (1720.00 MHz) 20175 (1732.50 MHz) 20300 (1745.00 MHz)	20 MHz	QPSK / 16QAM / 64QAM / 256QAM	1 RB Half RB Full RB
Modulation Characteristics	A	20175 (1732.50 MHz)	20 MHz	QPSK / 16QAM / 64QAM / 256QAM	Full RB
Peak to Average Ratio	A	19957 (1710.70 MHz) 20175 (1732.50 MHz) 20393 (1754.30 MHz)	1.4 MHz	QPSK / 16QAM / 64QAM / 256QAM	1 RB
	A	19965 (1711.50 MHz) 20175 (1732.50 MHz) 20385 (1753.50 MHz)	3 MHz	QPSK / 16QAM / 64QAM / 256QAM	1 RB
	A	19975 (1712.50 MHz) 20175 (1732.50 MHz) 20375 (1752.50 MHz)	5 MHz	QPSK / 16QAM / 64QAM / 256QAM	1 RB
	A	20000 (1715.00 MHz) 20175 (1732.50 MHz) 20350 (1750.00 MHz)	10 MHz	QPSK / 16QAM / 64QAM / 256QAM	1 RB
	A	20025 (1717.50 MHz) 20175 (1732.50 MHz) 20325 (1747.50 MHz)	15 MHz	QPSK / 16QAM / 64QAM / 256QAM	1 RB
	A	20050 (1720.00 MHz) 20175 (1732.50 MHz) 20300 (1745.00 MHz)	20 MHz	QPSK / 16QAM / 64QAM / 256QAM	1 RB

Test Item	EUT Configure Mode	Tested Channel	Channel Bandwidth	Modulation	Mode
Occupied Bandwidth	A	19957 (1710.70 MHz) 20175 (1732.50 MHz) 20393 (1754.30 MHz)	1.4 MHz	QPSK / 16QAM / 64QAM / 256QAM	Full RB
	A	19965 (1711.50 MHz) 20175 (1732.50 MHz) 20385 (1753.50 MHz)	3 MHz	QPSK / 16QAM / 64QAM / 256QAM	Full RB
	A	19975 (1712.50 MHz) 20175 (1732.50 MHz) 20375 (1752.50 MHz)	5 MHz	QPSK / 16QAM / 64QAM / 256QAM	Full RB
	A	20000 (1715.00 MHz) 20175 (1732.50 MHz) 20350 (1750.00 MHz)	10 MHz	QPSK / 16QAM / 64QAM / 256QAM	Full RB
	A	20025 (1717.50 MHz) 20175 (1732.50 MHz) 20325 (1747.50 MHz)	15 MHz	QPSK / 16QAM / 64QAM / 256QAM	Full RB
	A	20050 (1720.00 MHz) 20175 (1732.50 MHz) 20300 (1745.00 MHz)	20 MHz	QPSK / 16QAM / 64QAM / 256QAM	Full RB
Conducted Emission	A	19957 (1710.70 MHz) 20175 (1732.50 MHz) 20393 (1754.30 MHz)	1.4 MHz	QPSK	1 RB Full RB
	A	19965 (1711.50 MHz) 20175 (1732.50 MHz) 20385 (1753.50 MHz)	3 MHz	QPSK	1 RB Full RB
	A	19975 (1712.50 MHz) 20175 (1732.50 MHz) 20375 (1752.50 MHz)	5 MHz	QPSK	1 RB Full RB
	A	20000 (1715.00 MHz) 20175 (1732.50 MHz) 20350 (1750.00 MHz)	10 MHz	QPSK	1 RB Full RB
	A	20025 (1717.50 MHz) 20175 (1732.50 MHz) 20325 (1747.50 MHz)	15 MHz	QPSK	1 RB Full RB
	A	20050 (1720.00 MHz) 20175 (1732.50 MHz) 20300 (1745.00 MHz)	20 MHz	QPSK	1 RB Full RB
Radiated Spurious Emissions below 1GHz	A, B	20175 (1732.50 MHz)	20 MHz	QPSK	1 RB
Radiated Spurious Emissions above 1GHz	A, B	19957 (1710.70 MHz) 20175 (1732.50 MHz) 20393 (1754.30 MHz)	1.4 MHz	QPSK	1 RB
	A, B	19975 (1712.50 MHz) 20175 (1732.50 MHz) 20375 (1752.50 MHz)	5 MHz	QPSK	1 RB
	A, B	20050 (1720.00 MHz) 20175 (1732.50 MHz) 20300 (1745.00 MHz)	20 MHz	QPSK	1 RB

Test Item	EUT Configure Mode	Tested Channel	Channel Bandwidth	Modulation	Mode
Frequency Stability	A	19957 (1710.70 MHz) 20393 (1754.30 MHz)	1.4 MHz	QPSK	Full RB
	A	19965 (1711.50 MHz) 20385 (1753.50 MHz)	3 MHz	QPSK	Full RB
	A	19975 (1712.50 MHz) 20375 (1752.50 MHz)	5 MHz	QPSK	Full RB
	A	20000 (1715.00 MHz) 20350 (1750.00 MHz)	10 MHz	QPSK	Full RB
	A	20025 (1717.50 MHz) 20325 (1747.50 MHz)	15 MHz	QPSK	Full RB
	A	20050 (1720.00 MHz) 20300 (1745.00 MHz)	20 MHz	QPSK	Full RB

**For LTE Band 5**

Test Item	EUT Configure Mode	Tested Channel	Channel Bandwidth	Modulation	Mode
ERP	A	20407 (824.70 MHz) 20525 (836.50 MHz) 20643 (848.30 MHz)	1.4 MHz	QPSK / 16QAM / 64QAM / 256QAM	1 RB Half RB Full RB
	A	20415 (825.50 MHz) 20525 (836.50 MHz) 20635 (847.50 MHz)	3 MHz	QPSK / 16QAM / 64QAM / 256QAM	1 RB Half RB Full RB
	A	20425 (826.50 MHz) 20525 (836.50 MHz) 20625 (846.50 MHz)	5 MHz	QPSK / 16QAM / 64QAM / 256QAM	1 RB Half RB Full RB
	A	20450 (829.00 MHz) 20525 (836.50 MHz) 20600 (844.00 MHz)	10 MHz	QPSK / 16QAM / 64QAM / 256QAM	1 RB Half RB Full RB
Modulation Characteristics	A	20525 (836.50 MHz)	10 MHz	QPSK / 16QAM / 64QAM / 256QAM	Full RB
Peak to Average Ratio	A	20407 (824.70 MHz) 20525 (836.50 MHz) 20643 (848.30 MHz)	1.4 MHz	QPSK / 16QAM / 64QAM / 256QAM	1 RB
	A	20415 (825.50 MHz) 20525 (836.50 MHz) 20635 (847.50 MHz)	3 MHz	QPSK / 16QAM / 64QAM / 256QAM	1 RB
	A	20425 (826.50 MHz) 20525 (836.50 MHz) 20625 (846.50 MHz)	5 MHz	QPSK / 16QAM / 64QAM / 256QAM	1 RB
	A	20450 (829.00 MHz) 20525 (836.50 MHz) 20600 (844.00 MHz)	10 MHz	QPSK / 16QAM / 64QAM / 256QAM	1 RB
Occupied Bandwidth	A	20407 (824.70 MHz) 20525 (836.50 MHz) 20643 (848.30 MHz)	1.4 MHz	QPSK / 16QAM / 64QAM / 256QAM	Full RB
	A	20415 (825.50 MHz) 20525 (836.50 MHz) 20635 (847.50 MHz)	3 MHz	QPSK / 16QAM / 64QAM / 256QAM	Full RB
	A	20425 (826.50 MHz) 20525 (836.50 MHz) 20625 (846.50 MHz)	5 MHz	QPSK / 16QAM / 64QAM / 256QAM	Full RB
	A	20450 (829.00 MHz) 20525 (836.50 MHz) 20600 (844.00 MHz)	10 MHz	QPSK / 16QAM / 64QAM / 256QAM	Full RB

Test Item	EUT Configure Mode	Tested Channel	Channel Bandwidth	Modulation	Mode
Conducted Emission	A	20407 (824.70 MHz) 20525 (836.50 MHz) 20643 (848.30 MHz)	1.4 MHz	QPSK	1 RB Full RB
	A	20415 (825.50 MHz) 20525 (836.50 MHz) 20635 (847.50 MHz)	3 MHz	QPSK	1 RB Full RB
	A	20425 (826.50 MHz) 20525 (836.50 MHz) 20625 (846.50 MHz)	5 MHz	QPSK	1 RB Full RB
	A	20450 (829.00 MHz) 20525 (836.50 MHz) 20600 (844.00 MHz)	10 MHz	QPSK	1 RB Full RB
Radiated Spurious Emissions below 1GHz	A	20525 (836.50 MHz)	10 MHz	QPSK	1 RB
Radiated Spurious Emissions above 1GHz	A	20407 (824.70 MHz) 20525 (836.50 MHz) 20643 (848.30 MHz)	1.4 MHz	QPSK	1 RB
	A	20425 (826.50 MHz) 20525 (836.50 MHz) 20625 (846.50 MHz)	5 MHz	QPSK	1 RB
	A	20450 (829.00 MHz) 20525 (836.50 MHz) 20600 (844.00 MHz)	10 MHz	QPSK	1 RB
Frequency Stability	A	20407 (824.70 MHz) 20643 (848.30 MHz)	1.4 MHz	QPSK	Full RB
	A	20415 (825.50 MHz) 20635 (847.50 MHz)	3 MHz	QPSK	Full RB
	A	20425 (826.50 MHz) 20625 (846.50 MHz)	5 MHz	QPSK	Full RB
	A	20450 (829.00 MHz) 20600 (844.00 MHz)	10 MHz	QPSK	Full RB

## For LTE Band 12

Test Item	EUT Configure Mode	Tested Channel	Channel Bandwidth	Modulation	Mode
ERP	A	23017 (699.70 MHz) 23095 (707.50 MHz) 23173 (715.30 MHz)	1.4 MHz	QPSK / 16QAM / 64QAM / 256QAM	1 RB Half RB Full RB
	A	23025 (700.50 MHz) 23095 (707.50 MHz) 23165 (714.50 MHz)	3 MHz	QPSK / 16QAM / 64QAM / 256QAM	1 RB Half RB Full RB
	A	23035 (701.50 MHz) 23095 (707.50 MHz) 23155 (713.50 MHz)	5 MHz	QPSK / 16QAM / 64QAM / 256QAM	1 RB Half RB Full RB
	A	23060 (704.00 MHz) 23095 (707.50 MHz) 23130 (711.00 MHz)	10 MHz	QPSK / 16QAM / 64QAM / 256QAM	1 RB Half RB Full RB
Modulation Characteristics	A	23095 (707.50 MHz)	10 MHz	QPSK / 16QAM / 64QAM / 256QAM	Full RB
Peak to Average Ratio	A	23017 (699.70 MHz) 23095 (707.50 MHz) 23173 (715.30 MHz)	1.4 MHz	QPSK / 16QAM / 64QAM / 256QAM	1 RB
	A	23025 (700.50 MHz) 23095 (707.50 MHz) 23165 (714.50 MHz)	3 MHz	QPSK / 16QAM / 64QAM / 256QAM	1 RB
	A	23035 (701.50 MHz) 23095 (707.50 MHz) 23155 (713.50 MHz)	5 MHz	QPSK / 16QAM / 64QAM / 256QAM	1 RB
	A	23060 (704.00 MHz) 23095 (707.50 MHz) 23130 (711.00 MHz)	10 MHz	QPSK / 16QAM / 64QAM / 256QAM	1 RB
Occupied Bandwidth	A	23017 (699.70 MHz) 23095 (707.50 MHz) 23173 (715.30 MHz)	1.4 MHz	QPSK / 16QAM / 64QAM / 256QAM	Full RB
	A	23025 (700.50 MHz) 23095 (707.50 MHz) 23165 (714.50 MHz)	3 MHz	QPSK / 16QAM / 64QAM / 256QAM	Full RB
	A	23035 (701.50 MHz) 23095 (707.50 MHz) 23155 (713.50 MHz)	5 MHz	QPSK / 16QAM / 64QAM / 256QAM	Full RB
	A	23060 (704.00 MHz) 23095 (707.50 MHz) 23130 (711.00 MHz)	10 MHz	QPSK / 16QAM / 64QAM / 256QAM	Full RB

Test Item	EUT Configure Mode	Tested Channel	Channel Bandwidth	Modulation	Mode
Conducted Emission	A	23017 (699.70 MHz) 23095 (707.50 MHz) 23173 (715.30 MHz)	1.4 MHz	QPSK	1 RB Full RB
	A	23025 (700.50 MHz) 23095 (707.50 MHz) 23165 (714.50 MHz)	3 MHz	QPSK	1 RB Full RB
	A	23035 (701.50 MHz) 23095 (707.50 MHz) 23155 (713.50 MHz)	5 MHz	QPSK	1 RB Full RB
	A	23060 (704.00 MHz) 23095 (707.50 MHz) 23130 (711.00 MHz)	10 MHz	QPSK	1 RB Full RB
Radiated Spurious Emissions below 1GHz	A	23095 (707.50 MHz)	10 MHz	QPSK	1 RB
Radiated Spurious Emissions above 1GHz	A	23017 (699.70 MHz) 23095 (707.50 MHz) 23173 (715.30 MHz)	1.4 MHz	QPSK	1 RB
	A	23035 (701.50 MHz) 23095 (707.50 MHz) 23155 (713.50 MHz)	5 MHz	QPSK	1 RB
	A	23060 (704.00 MHz) 23095 (707.50 MHz) 23130 (711.00 MHz)	10 MHz	QPSK	1 RB
Frequency Stability	A	23017 (699.70 MHz) 23173 (715.30 MHz)	1.4 MHz	QPSK	Full RB
	A	23025 (700.50 MHz) 23165 (714.50 MHz)	3 MHz	QPSK	Full RB
	A	23035 (701.50 MHz) 23155 (713.50 MHz)	5 MHz	QPSK	Full RB
	A	23060 (704.00 MHz) 23130 (711.00 MHz)	10 MHz	QPSK	Full RB



## For LTE Band 14

Test Item	EUT Configure Mode	Tested Channel	Channel Bandwidth	Modulation	Mode
ERP	A	23305 (790.50 MHz) 23330 (793.00 MHz) 23355 (795.50 MHz)	5 MHz	QPSK / 16QAM / 64QAM / 256QAM	1 RB Half RB Full RB
	A	23330 (793.00 MHz)	10 MHz	QPSK / 16QAM / 64QAM / 256QAM	1 RB Half RB Full RB
Modulation Characteristics	A	23330 (793.00 MHz)	10 MHz	QPSK / 16QAM / 64QAM / 256QAM	Full RB
Occupied Bandwidth	A	23305 (790.50 MHz) 23330 (793.00 MHz) 23355 (795.50 MHz)	5 MHz	QPSK / 16QAM / 64QAM / 256QAM	Full RB
	A	23330 (793.00 MHz)	10 MHz	QPSK / 16QAM / 64QAM / 256QAM	Full RB
Conducted Emission	A	23305 (790.50 MHz) 23330 (793.00 MHz) 23355 (795.50 MHz)	5 MHz	QPSK	1 RB Full RB
	A	23330 (793.00 MHz)	10 MHz	QPSK	1 RB Full RB
Radiated Spurious Emissions below 1GHz	A	23330 (793.00 MHz)	10 MHz	QPSK	1 RB
Radiated Spurious Emissions above 1GHz	A	23305 (790.50 MHz) 23330 (793.00 MHz) 23355 (795.50 MHz)	5 MHz	QPSK	1 RB
	A	23330 (793.00 MHz)	10 MHz	QPSK	1 RB
Frequency Stability	A	23305 (790.50 MHz) 23355 (795.50 MHz)	5 MHz	QPSK	Full RB
	A	23330 (793.00 MHz)	10 MHz	QPSK	Full RB

**For LTE Band 30**

Test Item	EUT Configure Mode	Tested Channel	Channel Bandwidth	Modulation	Mode
EIRP	A, B	27685 (2307.50 MHz) 27710 (2310.00 MHz) 27735 (2312.50 MHz)	5 MHz	QPSK / 16QAM / 64QAM / 256QAM	1 RB Half RB Full RB
	A, B	27710 (2310.00 MHz)	10 MHz	QPSK / 16QAM / 64QAM / 256QAM	1 RB Half RB Full RB
Modulation Characteristics	A	27710 (2310.00 MHz)	10 MHz	QPSK / 16QAM / 64QAM / 256QAM	Full RB
Occupied Bandwidth	A	27685 (2307.50 MHz) 27710 (2310.00 MHz) 27735 (2312.50 MHz)	5 MHz	QPSK / 16QAM / 64QAM / 256QAM	Full RB
	A	27710 (2310.00 MHz)	10 MHz	QPSK / 16QAM / 64QAM / 256QAM	Full RB
Conducted Emission	A	27685 (2307.50 MHz) 27710 (2310.00 MHz) 27735 (2312.50 MHz)	5 MHz	QPSK	1 RB Full RB
	A	27710 (2310.00 MHz)	10 MHz	QPSK	1 RB Full RB
Radiated Spurious Emissions below 1GHz	A, B	27710 (2310.00 MHz)	10 MHz	QPSK	1 RB
Radiated Spurious Emissions above 1GHz	A, B	27685 (2307.50 MHz) 27710 (2310.00 MHz) 27735 (2312.50 MHz)	5 MHz	QPSK	1 RB
	A, B	27710 (2310.00 MHz)	10 MHz	QPSK	1 RB
Frequency Stability	A	27685 (2307.50 MHz) 27735 (2312.50 MHz)	5 MHz	QPSK	Full RB
	A	27710 (2310.00 MHz)	10 MHz	QPSK	Full RB

**For LTE Band 66**

Test Item	EUT Configure Mode	Tested Channel	Channel Bandwidth	Modulation	Mode
EIRP	A, B	131979 (1710.70 MHz) 132322 (1745.00 MHz) 132665 (1779.30 MHz)	1.4 MHz	QPSK / 16QAM / 64QAM / 256QAM	1 RB Half RB Full RB
	A, B	131987 (1711.50 MHz) 132322 (1745.00 MHz) 132657 (1778.50 MHz)	3 MHz	QPSK / 16QAM / 64QAM / 256QAM	1 RB Half RB Full RB
	A, B	131997 (1712.50 MHz) 132322 (1745.00 MHz) 132647 (1777.50 MHz)	5 MHz	QPSK / 16QAM / 64QAM / 256QAM	1 RB Half RB Full RB
	A, B	132022 (1715.00 MHz) 132322 (1745.00 MHz) 132622 (1775.00 MHz)	10 MHz	QPSK / 16QAM / 64QAM / 256QAM	1 RB Half RB Full RB
	A, B	132047 (1717.50 MHz) 132322 (1745.00 MHz) 132597 (1772.50 MHz)	15 MHz	QPSK / 16QAM / 64QAM / 256QAM	1 RB Half RB Full RB
	A, B	132072 (1720.00 MHz) 132322 (1745.00 MHz) 132572 (1770.00 MHz)	20 MHz	QPSK / 16QAM / 64QAM / 256QAM	1 RB Half RB Full RB
Modulation Characteristics	A	132322 (1745.00 MHz)	20 MHz	QPSK / 16QAM / 64QAM / 256QAM	Full RB
Peak to Average Ratio	A	131979 (1710.70 MHz) 132322 (1745.00 MHz) 132665 (1779.30 MHz)	1.4 MHz	QPSK / 16QAM / 64QAM / 256QAM	1 RB
	A	131987 (1711.50 MHz) 132322 (1745.00 MHz) 132657 (1778.50 MHz)	3 MHz	QPSK / 16QAM / 64QAM / 256QAM	1 RB
	A	131997 (1712.50 MHz) 132322 (1745.00 MHz) 132647 (1777.50 MHz)	5 MHz	QPSK / 16QAM / 64QAM / 256QAM	1 RB
	A	132022 (1715.00 MHz) 132322 (1745.00 MHz) 132622 (1775.00 MHz)	10 MHz	QPSK / 16QAM / 64QAM / 256QAM	1 RB
	A	132047 (1717.50 MHz) 132322 (1745.00 MHz) 132597 (1772.50 MHz)	15 MHz	QPSK / 16QAM / 64QAM / 256QAM	1 RB
	A	132072 (1720.00 MHz) 132322 (1745.00 MHz) 132572 (1770.00 MHz)	20 MHz	QPSK / 16QAM / 64QAM / 256QAM	1 RB

Test Item	EUT Configure Mode	Tested Channel	Channel Bandwidth	Modulation	Mode
Occupied Bandwidth	A	131979 (1710.70 MHz) 132322 (1745.00 MHz) 132665 (1779.30 MHz)	1.4 MHz	QPSK / 16QAM / 64QAM / 256QAM	Full RB
	A	131987 (1711.50 MHz) 132322 (1745.00 MHz) 132657 (1778.50 MHz)	3 MHz	QPSK / 16QAM / 64QAM / 256QAM	Full RB
	A	131997 (1712.50 MHz) 132322 (1745.00 MHz) 132647 (1777.50 MHz)	5 MHz	QPSK / 16QAM / 64QAM / 256QAM	Full RB
	A	132022 (1715.00 MHz) 132322 (1745.00 MHz) 132622 (1775.00 MHz)	10 MHz	QPSK / 16QAM / 64QAM / 256QAM	Full RB
	A	132047 (1717.50 MHz) 132322 (1745.00 MHz) 132597 (1772.50 MHz)	15 MHz	QPSK / 16QAM / 64QAM / 256QAM	Full RB
	A	132072 (1720.00 MHz) 132322 (1745.00 MHz) 132572 (1770.00 MHz)	20 MHz	QPSK / 16QAM / 64QAM / 256QAM	Full RB
Conducted Emission	A	131979 (1710.70 MHz) 132322 (1745.00 MHz) 132665 (1779.30 MHz)	1.4 MHz	QPSK	1 RB Full RB
	A	131987 (1711.50 MHz) 132322 (1745.00 MHz) 132657 (1778.50 MHz)	3 MHz	QPSK	1 RB Full RB
	A	131997 (1712.50 MHz) 132322 (1745.00 MHz) 132647 (1777.50 MHz)	5 MHz	QPSK	1 RB Full RB
	A	132022 (1715.00 MHz) 132322 (1745.00 MHz) 132622 (1775.00 MHz)	10 MHz	QPSK	1 RB Full RB
	A	132047 (1717.50 MHz) 132322 (1745.00 MHz) 132597 (1772.50 MHz)	15 MHz	QPSK	1 RB Full RB
	A	132072 (1720.00 MHz) 132322 (1745.00 MHz) 132572 (1770.00 MHz)	20 MHz	QPSK	1 RB Full RB
Radiated Spurious Emissions below 1GHz	A, B	132322 (1745.00 MHz)	20 MHz	QPSK	1 RB
Radiated Spurious Emissions above 1GHz	A, B	131979 (1710.70 MHz) 132322 (1745.00 MHz) 132665 (1779.30 MHz)	1.4 MHz	QPSK	1 RB
	A, B	131997 (1712.50 MHz) 132322 (1745.00 MHz) 132647 (1777.50 MHz)	5 MHz	QPSK	1 RB
	A, B	132072 (1720.00 MHz) 132322 (1745.00 MHz) 132572 (1770.00 MHz)	20 MHz	QPSK	1 RB

Test Item	EUT Configure Mode	Tested Channel	Channel Bandwidth	Modulation	Mode
Frequency Stability	A	131979 (1710.70 MHz) 132665 (1779.30 MHz)	1.4 MHz	QPSK	Full RB
	A	131987 (1711.50 MHz) 132657 (1778.50 MHz)	3 MHz	QPSK	Full RB
	A	131997 (1712.50 MHz) 132647 (1777.50 MHz)	5 MHz	QPSK	Full RB
	A	132022 (1715.00 MHz) 132622 (1775.00 MHz)	10 MHz	QPSK	Full RB
	A	132047 (1717.50 MHz) 132597 (1772.50 MHz)	15 MHz	QPSK	Full RB
	A	132072 (1720.00 MHz) 132572 (1770.00 MHz)	20 MHz	QPSK	Full RB

### 3.4 Test Program Used and Operation Descriptions

There is no need to controlling software during the test, and the EUT can be paired with the Radio Communication Analyzer to test the connection when it is powered on.

### 3.5 Connection Diagram of EUT and Peripheral Devices

Test Mode A

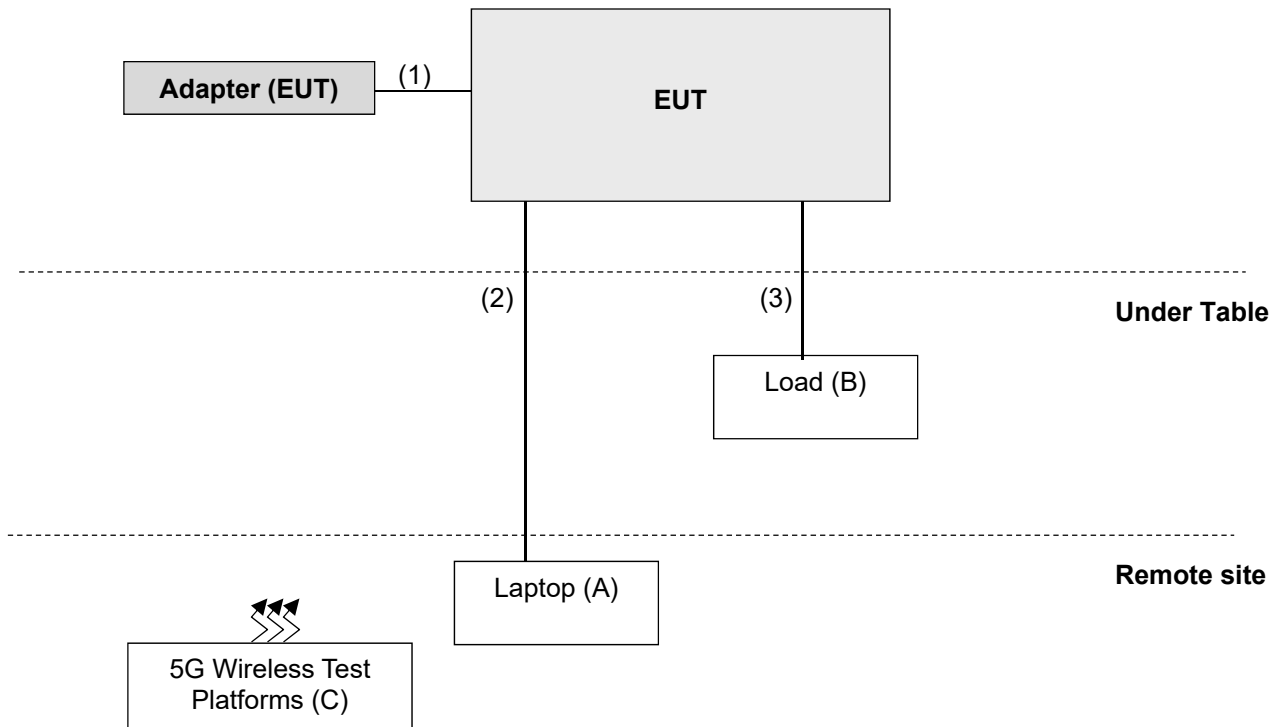

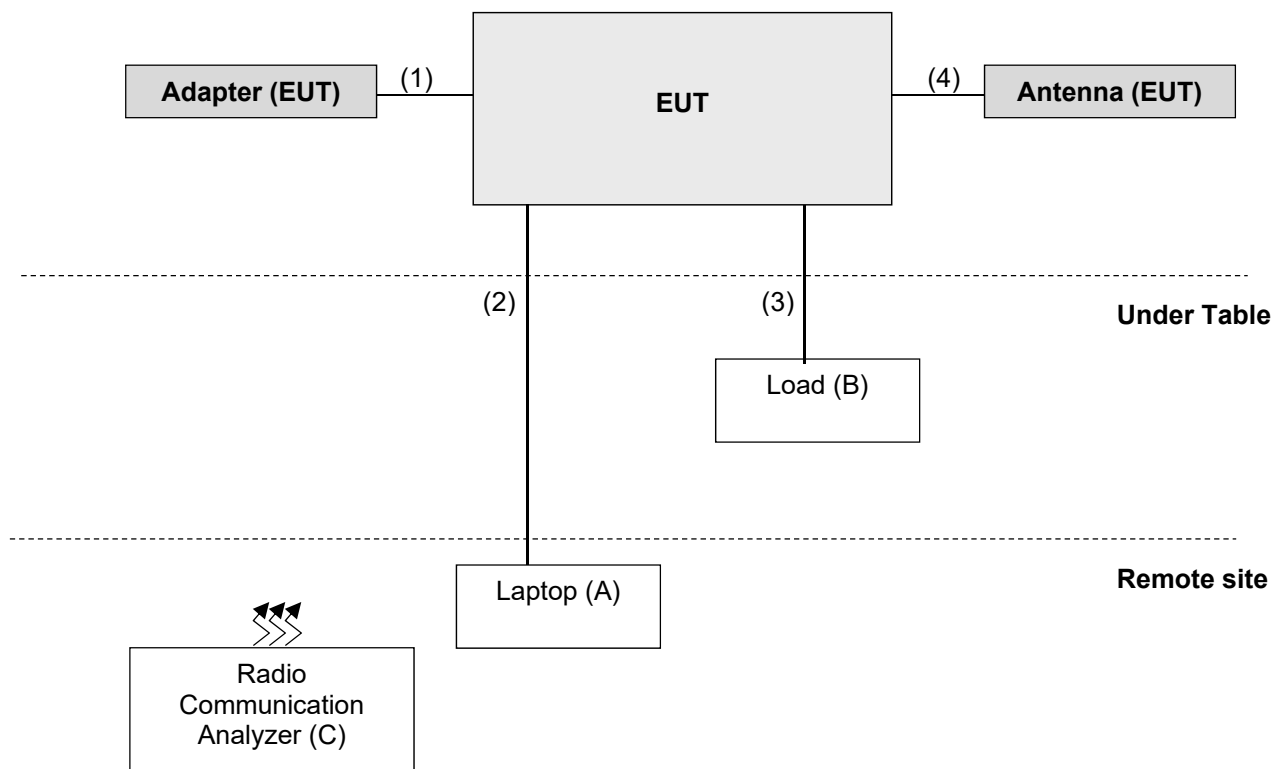

### 3.6 Configuration of Peripheral Devices and Cable Connections

ID	Product	Brand	Model No.	Serial No.	FCC ID	Remarks
A	Laptop	DELL	Inspiron 14R	8LRKKW1	NA	Provided by Lab
B	Load	NA	NA	NA	NA	-
C	Radio Communication Analyzer	Anritsu	MT8821C	6201462755	NA	Provided by Lab

ID	Cable Descriptions	Qty.	Length (m)	Shielding (Yes/No)	Cores (Qty.)	Remarks
1	DC Cable	1	1.5	N	0	Accessory of EUT
2	LAN Cable	1	10	N	0	Provided by Lab
3	LAN Cable	3	1.8	N	0	Provided by Lab
4	ANT Cable	1	4.5	Y	0	Accessory of EUT

## 4 Test Instruments

The calibration interval of the all test instruments are 12 months and the calibrations are traceable to NML/ROC and NIST/USA.

### 4.1 Effective Radiated Power and Equivalent Isotropically Radiated Power

Description Manufacturer	Model No.	Serial No.	Calibrated Date	Calibrated Until
PXA Signal Analyzer Keysight	N9030B	MY57140488	2023/3/6	2024/3/5
Radio Communication Analyzer Anritsu	MT8821C	6272278312	2023/7/6	2024/7/5
Software BV	ADT_RF Test Software V7.6.5.4	N/A	N/A	N/A

Notes:

1. The test was performed in Oven room.
2. Tested Date: 2023/11/10 ~ 2023/11/23

Description Manufacturer	Model No.	Serial No.	Calibrated Date	Calibrated Until
Antenna Tower & Turn Max-Full	MFA-440H	AT93021705	N/A	N/A
Boresight antenna tower fixture BV	BAF-02	7	N/A	N/A
EXA Signal Analyzer Agilent	N9010A	MY52220207	2023/1/3	2024/1/2
Horn Antenna Schwarzbeck	BBHA 9120D	9120D-969	2023/11/12	2024/11/11
	BBHA 9170	148	2023/11/12	2024/11/11
MXE EMI Receiver Keysight	N9038A	MY55420137	2023/5/3	2024/5/2
Notch Filter Micro-Tronics	BRM17690	004	2023/1/11	2024/1/10
	BRM50716	060	2023/1/11	2024/1/10
Preamplifier EMCI	EMC 012645	980115	2023/9/27	2024/9/26
	EMC 184045	980116	2023/9/27	2024/9/26
RF Coaxial Cable EMCI	EMC102-KM-KM-600	150928	2023/7/8	2024/7/7
	EMC102-KM-KM-3000	150929	2023/7/8	2024/7/7
	EMC104-SM-SM- 8000+3000	171005	2023/9/27	2024/9/26
RF Coaxial Cable HUBER+SUHNER	SUCOFLEX 104	EMC104-SM-SM- 1000(140807)	2023/9/27	2024/9/26
Software BV ADT	ADT_Radiated_ V7.6.15.9.5	N/A	N/A	N/A
Turn Table Max-Full	MFT-201SS	N/A	N/A	N/A
Turn Table Controller Max-Full	MG-7802	N/A	N/A	N/A

Notes:

1. The test was performed in HY - 966 chamber 5.
2. Tested Date: 2023/12/7 ~ 2023/12/12

## 4.2 Modulation Characteristics

Description Manufacturer	Model No.	Serial No.	Calibrated Date	Calibrated Until
PXA Signal Analyzer Keysight	N9030B	MY57140488	2023/3/6	2024/3/5
Radio Communication Analyzer Anritsu	MT8821C	6272278312	2023/7/6	2024/7/5
Software BV	ADT_RF Test Software V7.6.5.4	N/A	N/A	N/A

Notes:

1. The test was performed in Oven room.
2. Tested Date: 2023/11/7 ~ 2023/11/23

## 4.3 Peak to Average Ratio

Refer to section 4.2 to get information of the instruments.

## 4.4 Bandwidth

Refer to section 4.2 to get information of the instruments.

## 4.5 Conducted Spurious Emissions

Refer to section 4.2 to get information of the instruments.



#### 4.6 Radiated Spurious Emissions below 1GHz

Description Manufacturer	Model No.	Serial No.	Calibrated Date	Calibrated Until
Antenna Tower & Turn Max-Full	MFA-440H	AT93021705	N/A	N/A
Bi_Log Antenna Schwarzbeck	VULB 9168	9168-472	2023/10/16	2024/10/15
EXA Signal Analyzer Agilent	N9010A	MY52220207	2023/1/3	2024/1/2
Loop Antenna Electro-Metrics	EM-6879	269	2023/9/23	2024/9/22
Loop Antenna TESEQ	HLA 6121	45745	2023/8/8	2024/8/7
MXE EMI Receiver Keysight	N9038A	MY55420137	2023/5/3	2024/5/2
Preamplifier EMCI	EMC 330H	980112	2023/9/27	2024/9/26
	EMC001340	980201	2023/9/27	2024/9/26
RF Coaxial Cable EMCI	5D-NM-BM	140903+140902	2023/1/7	2024/1/6
RF Coaxial Cable Woken	8D-FB	Cable-Ch10-01	2023/9/27	2024/9/26
Software BV ADT	ADT_Radiated_ V7.6.15.9.5	N/A	N/A	N/A
Turn Table Max-Full	MFT-201SS	N/A	N/A	N/A
Turn Table Controller Max-Full	MG-7802	N/A	N/A	N/A

Notes:

1. The test was performed in HY - 966 chamber 5.
2. Tested Date: 2023/12/12 ~ 2023/12/13

#### 4.7 Radiated Spurious Emissions above 1GHz

Description Manufacturer	Model No.	Serial No.	Calibrated Date	Calibrated Until
Antenna Tower & Turn Max-Full	MFA-440H	AT93021705	N/A	N/A
Boresight antenna tower fixture BV	BAF-02	7	N/A	N/A
EXA Signal Analyzer Agilent	N9010A	MY52220207	2023/1/3	2024/1/2
Horn Antenna Schwarzbeck	BBHA 9120D	9120D-969	2023/11/12	2024/11/11
	BBHA 9170	148	2023/11/12	2024/11/11
MXE EMI Receiver Keysight	N9038A	MY55420137	2023/5/3	2024/5/2
Notch Filter Micro-Tronics	BRM17690	004	2023/1/11	2024/1/10
	BRM50716	060	2023/1/11	2024/1/10
Preamplifier EMCI	EMC 012645	980115	2023/9/27	2024/9/26
	EMC 184045	980116	2023/9/27	2024/9/26
RF Coaxial Cable EMCI	EMC102-KM-KM-600	150928	2023/7/8	2024/7/7
	EMC102-KM-KM-3000	150929	2023/7/8	2024/7/7
	EMC104-SM-SM- 8000+3000	171005	2023/9/27	2024/9/26
RF Coaxial Cable HUBER+SUHNER	SUCOFLEX 104	EMC104-SM-SM- 1000(140807)	2023/9/27	2024/9/26
Software BV ADT	ADT_Radiated_ V7.6.15.9.5	N/A	N/A	N/A
Turn Table Max-Full	MFT-201SS	N/A	N/A	N/A
Turn Table Controller Max-Full	MG-7802	N/A	N/A	N/A

Notes:

3. The test was performed in HY - 966 chamber 5.
4. Tested Date: 2023/12/7 ~ 2023/12/12

#### 4.8 Frequency Stability

Description Manufacturer	Model No.	Serial No.	Calibrated Date	Calibrated Until
AC Power Supply Extech	6905S	1991553	N/A	N/A
Digital Multimeter Fluke	87-III	70360742	2023/07/06	2024/07/05
Software BV	ADT_RF Test Software V6.6.5.4	N/A	N/A	N/A
Spectrum Analyzer R&S	FSV40	100980	2023/05/03	2024/05/02
Temperature & Humidity Chamber TERCHY	HRM-120RF	931022	2022/12/27	2023/12/26
Radio Communication Analyzer Anritsu	MT8821C	6201462755	2023/3/3	2024/3/2

Notes:

1. The test was performed in Oven room.
2. Tested Date: 2023/12/7 ~ 2023/12/12

## 5 Limits of Test Items

### 5.1 Effective Radiated Power and Equivalent Isotropically Radiated Power

#### For LTE Band 2:

Mobile and portable stations are limited to 2 watts EIRP.

#### For LTE Band 4, LTE Band 66:

Fixed, mobile, and portable (hand-held) stations operating in the 1710-1755 MHz band and mobile and portable stations operating in the 1695-1710 MHz and 1755-1780 MHz bands are limited to 1 watt EIRP.

#### For LTE Band 5:

The ERP of mobile transmitters and auxiliary test transmitters must not exceed 7 watts.

#### For LTE Band 12:

Portable stations (hand-held devices) in the 600 MHz uplink band and the 698-746 MHz band, and fixed and mobile stations in the 600 MHz uplink band are limited to 3 watts ERP.

#### For LTE Band 14:

Portable stations (hand-held devices) transmitting in the 758-768 MHz band and the 788-798 MHz band are limited to 3 watts ERP.

#### For LTE Band 30:

For mobile and portable stations transmitting in the 2305-2315 MHz band or the 2350-2360 MHz band, the average EIRP must not exceed 50 milliwatts within any 1 megahertz of authorized bandwidth, except that for mobile and portable stations compliant with 3GPP LTE standards or another advanced mobile broadband protocol that avoids concentrating energy at the edge of the operating band the average EIRP must not exceed 250 milliwatts within any 5 megahertz of authorized bandwidth but may exceed 50 milliwatts within any 1 megahertz of authorized bandwidth.

### 5.2 Modulation Characteristics

A curve or equivalent data which shows that the equipment will meet the modulation requirements of the rules under which the equipment is to be licensed.

### 5.3 Peak to Average Ratio

In measuring transmissions in this band using an average power technique, the peak to-average ratio (PAR) of the transmission may not exceed 13 dB.

### 5.4 Bandwidth

According to FCC 47 CFR part 2.1049, the occupied bandwidth, that is the frequency bandwidth such that, below its lower and above its upper frequency limits, the mean powers radiated are each equal to 0.5% of the total mean power radiated by a given emission.

## 5.5 Conducted Spurious Emissions

### For LTE Band 2, LTE Band 5:

The power of any emission outside of the authorized operating frequency ranges must be attenuated below the transmitting power (P) by a factor of at least  $43 + 10 \log(P)$  dB. The emission limit equal to  $-13$  dBm.

### For LTE Band 4:

According to FCC 47 CFR part 27.53(h), for operations in the 1695-1710 MHz, 1710-1755 MHz, 1755-1780 MHz, 1915-1920 MHz, 1995-2000 MHz, 2000-2020 MHz, 2110-2155 MHz, 2155-2180 MHz, and 2180-2200 MHz bands, the power of any emission outside a licensee's frequency block shall be attenuated below the transmitter power (P) in watts by at least  $43 + 10 \log(P)$  dB. However, in the 1 megahertz bands immediately outside and adjacent to the licensee's frequency block, a resolution bandwidth of at least one percent of the emission bandwidth of the fundamental emission of the transmitter may be employed.

### For LTE Band 12:

According to FCC 47 CFR part 27.53(g), for operations in the 600 MHz band and the 698-746 MHz band, the power of any emission outside a licensee's frequency band(s) of operation shall be attenuated below the transmitter power (P) within the licensed band(s) of operation, measured in watts, by at least  $43 + 10 \log(P)$  dB. Compliance with this provision is based on the use of measurement instrumentation employing a resolution bandwidth of 100 kilohertz or greater. However, in the 100 kilohertz bands immediately outside and adjacent to a licensee's frequency block, a resolution bandwidth of at least 30 kHz may be employed.

### For LTE Band 14:

According to FCC 47 CFR part 90.543 (e), for operations in the 758-768 MHz and the 788-798 MHz bands, the power of any emission outside the licensee's frequency band(s) of operation shall be attenuated below the transmitter power (P) within the licensed band(s) of operation, measured in watts, in accordance with the following:

- (1) On all frequencies between 769-775 MHz and 799-805 MHz, by a factor not less than  $65 + 10 \log(P)$  dB in a 6.25 kHz band segment, for mobile and portable stations.
- (2) On any frequency between 775-788 MHz, above 805 MHz, and below 758 MHz, by at least  $43 + 10 \log(P)$  dB.

According to FCC 47 CFR part 90.543 (f), for operations in the 758-775 MHz and 788-805 MHz bands, all emissions including harmonics in the band 1559-1610 MHz shall be limited to  $-70$  dBW/MHz equivalent isotropically radiated power (EIRP) for wideband signals, and  $-80$  dBW EIRP for discrete emissions of less than 700 Hz bandwidth.

### For LTE Band 30:

According to FCC 47 CFR part 27.53(a)(4), for mobile and portable stations operating in the 2305-2315 MHz and 2350-2360 MHz bands:

- (i) By a factor of not less than:  $43 + 10 \log(P)$  dB on all frequencies between 2305 MHz and 2320 MHz and on all frequencies between 2345 MHz and 2360 MHz that are outside the licensed band(s) of operation, not less than  $55 + 10 \log(P)$  dB on all frequencies between 2320 MHz and 2324 MHz and on all frequencies between 2341 MHz and 2345 MHz, not less than  $61 + 10 \log(P)$  dB on all frequencies between 2324 MHz and 2328 MHz and on all frequencies between 2337 MHz and 2341 MHz, and not less than  $67 + 10 \log(P)$  dB on all frequencies between 2328 MHz and 2337 MHz;
- (ii) By a factor of not less than  $43 + 10 \log(P)$  dB on all frequencies between 2300 MHz and 2305 MHz,  $55 + 10 \log(P)$  dB on all frequencies between 2296 MHz and 2300 MHz,  $61 + 10 \log(P)$  dB on all frequencies between 2292 MHz and 2296 MHz,  $67 + 10 \log(P)$  dB on all frequencies between 2288 MHz and 2292 MHz, and  $70 + 10 \log(P)$  dB below 2288 MHz;
- (iii) By a factor of not less than  $43 + 10 \log(P)$  dB on all frequencies between 2360 MHz and 2365 MHz, and not less than  $70 + 10 \log(P)$  dB above 2365 MHz.
- (iv) Compliance with these rules is based on the use of measurement instrumentation employing a resolution bandwidth of 1 MHz or greater. However, in the 1 MHz bands immediately outside and adjacent to the channel blocks at 2305 MHz, 2310 MHz, 2315 MHz, 2320 MHz, 2345 MHz, 2350 MHz, 2355 MHz, and 2360 MHz, a resolution bandwidth of at least 1 percent of the emission bandwidth of the fundamental emission of the transmitter may be employed.

#### For LTE Band 66:

According to FCC 47 CFR part 27.53(h), for operations in the 1695-1710 MHz, 1710-1755 MHz, 1755-1780 MHz, 1915-1920 MHz, 1995-2000 MHz, 2000-2020 MHz, 2110-2155 MHz, 2155-2180 MHz, and 2180-2200 MHz bands, the power of any emission outside a licensee's frequency block shall be attenuated below the transmitter power (P) in watts by at least  $43 + 10 \log (P)$  dB. However, in the 1 megahertz bands immediately outside and adjacent to the licensee's frequency block, a resolution bandwidth of at least one percent of the emission bandwidth of the fundamental emission of the transmitter may be employed.

### 5.6 Radiated Spurious Emissions below 1GHz

#### For LTE Band 2, LTE Band 5:

The power of any emission outside of the authorized operating frequency ranges must be attenuated below the transmitting power (P) by a factor of at least  $43 + 10 \log(P)$  dB. The emission limit equal to  $-13$  dBm.

#### For LTE Band 4:

According to FCC 47 CFR part 27.53(h), for operations in the 1695-1710 MHz, 1710-1755 MHz, 1755-1780 MHz bands, the power of any emission outside a licensee's frequency block shall be attenuated below the transmitter power (P) in watts by at least  $43 + 10 \log (P)$  dB. The limit of emission is equal to  $-13$  dBm.

#### For LTE Band 12:

According to FCC 47 CFR part 27.53(g), for operations in the 600 MHz band and the 698-746 MHz band, the power of any emission outside a licensee's frequency band(s) of operation shall be attenuated below the transmitter power (P) within the licensed band(s) of operation, measured in watts, by at least  $43 + 10 \log (P)$  dB. The limit of emissions is equal to  $-13$  dBm.

#### For LTE Band 14:

According to FCC 47 CFR part 90.543 (e), for operations in the 758-768 MHz and the 788-798 MHz bands, the power of any emission outside the licensee's frequency band(s) of operation shall be attenuated below the transmitter power (P) in watts by at least  $43 + 10 \log (P)$  dB.

According to FCC 47 CFR part 90.543 (f), for operations in the 758-775 MHz and 788-805 MHz bands, all emissions including harmonics in the band 1559-1610 MHz shall be limited to  $-70$  dBW/MHz equivalent isotropically radiated power (EIRP) for wideband signals, and  $-80$  dBW EIRP for discrete emissions of less than 700 Hz bandwidth.

#### For LTE Band 30:

According to FCC 47 CFR part 27.53(a)(4)(ii)(iii), the power of any emission outside a licensee's frequency block shall be attenuated below the transmitter power (P) by at least  $70 + 10 \log (P)$  dB. The limit of emission is equal to  $-40$  dBm.

#### For LTE Band 66:

According to FCC 47 CFR part 27.53(h), for operations in the 1695-1710 MHz, 1710-1755 MHz, 1755-1780 MHz bands, the power of any emission outside a licensee's frequency block shall be attenuated below the transmitter power (P) in watts by at least  $43 + 10 \log (P)$  dB. The limit of emission is equal to  $-13$  dBm.

## 5.7 Radiated Spurious Emissions above 1GHz

### For LTE Band 2, LTE Band 5:

The power of any emission outside of the authorized operating frequency ranges must be attenuated below the transmitting power (P) by a factor of at least  $43 + 10 \log(P)$  dB. The emission limit equal to  $-13$  dBm.

### For LTE Band 4:

According to FCC 47 CFR part 27.53(h), for operations in the 1695-1710 MHz, 1710-1755 MHz, 1755-1780 MHz bands, the power of any emission outside a licensee's frequency block shall be attenuated below the transmitter power (P) in watts by at least  $43 + 10 \log(P)$  dB. The limit of emission is equal to  $-13$  dBm.

### For LTE Band 12:

According to FCC 47 CFR part 27.53(g), for operations in the 600 MHz band and the 698-746 MHz band, the power of any emission outside a licensee's frequency band(s) of operation shall be attenuated below the transmitter power (P) within the licensed band(s) of operation, measured in watts, by at least  $43 + 10 \log(P)$  dB. The limit of emissions is equal to  $-13$  dBm.

### For LTE Band 14:

According to FCC 47 CFR part 90.543 (e), for operations in the 758-768 MHz and the 788-798 MHz bands, the power of any emission outside the licensee's frequency band(s) of operation shall be attenuated below the transmitter power (P) in watts by at least  $43 + 10 \log(P)$  dB.

According to FCC 47 CFR part 90.543 (f), for operations in the 758-775 MHz and 788-805 MHz bands, all emissions including harmonics in the band 1559-1610 MHz shall be limited to  $-70$  dBW/MHz equivalent isotropically radiated power (EIRP) for wideband signals, and  $-80$  dBW EIRP for discrete emissions of less than 700 Hz bandwidth.

### For LTE Band 30:

According to FCC 47 CFR part 27.53(a)(4)(ii)(iii), the power of any emission outside a licensee's frequency block shall be attenuated below the transmitter power (P) by at least  $70 + 10 \log(P)$  dB. The limit of emission is equal to  $-40$  dBm.

### For LTE Band 66:

According to FCC 47 CFR part 27.53(h), for operations in the 1695-1710 MHz, 1710-1755 MHz, 1755-1780 MHz bands, the power of any emission outside a licensee's frequency block shall be attenuated below the transmitter power (P) in watts by at least  $43 + 10 \log(P)$  dB. The limit of emission is equal to  $-13$  dBm.

## 5.8 Frequency Stability

### For LTE Band 5:

1.5 ppm is for base and fixed station. 2.5 ppm is for mobile station.

### For LTE Band 2, LTE Band 4, LTE Band 12, LTE Band 30, LTE Band 66:

The frequency stability shall be sufficient to ensure that the fundamental emissions stay within the authorized bands of operation (authorized frequency block).

### For LTE Band 14:

The frequency stability of mobile, portable and control transmitters operating in the wideband segment must be 1.25 parts per million or better when AFC is locked to a base station, and 5 parts per million or better when AFC is not locked.

## 6 Test Arrangements

### 6.1 Effective Radiated Power and Equivalent Isotropically Radiated Power

#### 6.1.1 Test Setup

##### Conducted Power Measurement:

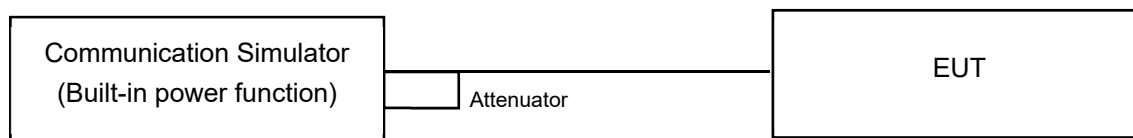

#### 6.1.2 Test Procedure

##### Conducted Power Measurement:

The EUT is configured by emulator to set data modulation and maximum power using WWAN technology. The average (rms) power measurement was performed on emulator and power value was measured from power function on emulator. Set the EUT to transmit under low, middle and high channel and record the power level shown on simulator. The EUT is configured by emulator to set data modulation and maximum power using WWAN technology and link to spectrum analyzer measurements. Set the EUT to transmit under low, middle and high channel and record the power level shown on spectrum analyzer. Power measurements use detector average (rms).

Measurement method refers to ANSI C63.26 section 5.2.4.4.

- a. Set span to 2 × to 3 × the OBW.
- b. Set RBW = 1% to 5% of the OBW.
- c. Set VBW ≥ 3 × RBW.
- d. Set number of measurement points in sweep ≥ 2 × span / RBW.
- e. Set Sweep time = auto-couple.
- f. Detector = power averaging (rms).
- g. Set sweep trigger to “free run.”
- h. Trace average at least 100 traces in power averaging (rms) mode.
- i. Compute power by integrating the spectrum across the OBW of the signal using the instrument’s band or channel power measurement function with band/channel limits set equal to the OBW band edges.
- j. If Duty cycle < 98%, Add 10 log (1/duty cycle) to the measured power level to compute the average power during continuous transmission.

##### Maximum EIRP / ERP

The relevant equation for determining the maximum ERP or EIRP from the measured RF output power is given in Equation as follows:

$$\text{EIRP} = P_{\text{Meas}} + G_T$$

$$\text{ERP} = P_{\text{Meas}} + G_T - 2.15$$

where

ERP or EIRP effective radiated power or equivalent isotropically radiated power, respectively

(expressed in the same units as  $P_{\text{Meas}}$ , e.g., dBm or dBW)

$P_{\text{Meas}}$  measured transmitter output power or PSD, in dBm or dBW

$G_T$  gain of the transmitting antenna, in dBd (ERP) or dBi (EIRP)



## 6.2 Modulation Characteristics

### 6.2.1 Test Setup

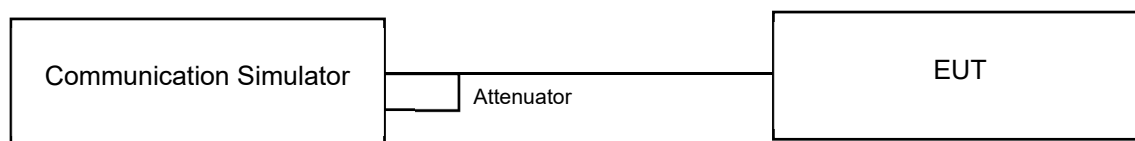

### 6.2.2 Test Procedure

Connect the EUT to Communication Simulator via the antenna connector, the frequency band is set as EUT supported Modulation and Channels, the EUT output is matched with 50 ohm load, the waveform quality and constellation of the EUT was tested.

## 6.3 Peak to Average Ratio

### 6.3.1 Test Setup

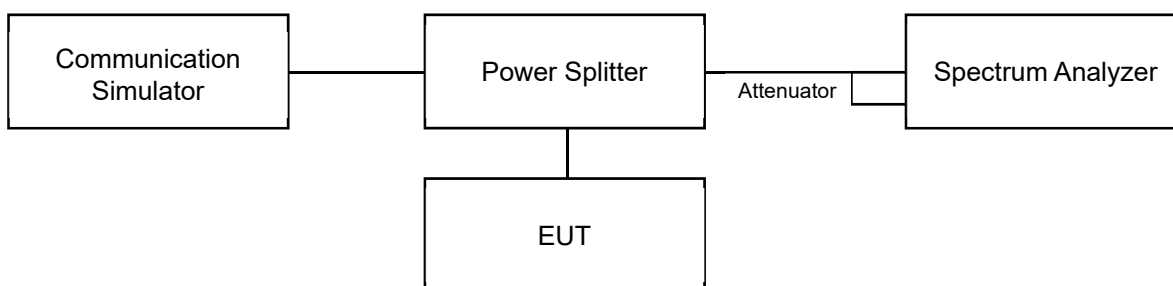

### 6.3.2 Test Procedure

- Set resolution/measurement bandwidth  $\geq$  signal's occupied bandwidth;
- Set the number of counts to a value that stabilizes the measured CCDF curve;
- Record the maximum PAPR level associated with a probability of 0.1%.

## 6.4 Bandwidth

### 6.4.1 Test Setup

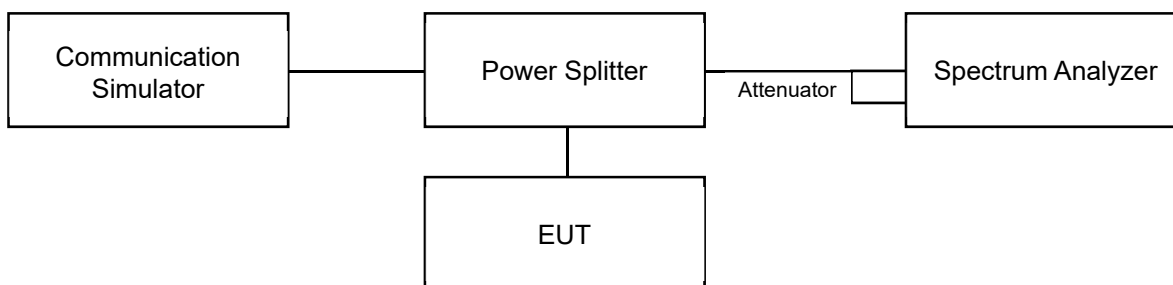

### 6.4.2 Test Procedure

For the 26 dBc bandwidth measurement method, please refer to section 5.4.3 of ANSI C63.26.

- a. The spectrum analyzer center frequency is set to the nominal EUT channel center frequency. The span range for the spectrum analyzer shall be wide enough to see sufficient roll off of the signal to make the measurement.
- b. The nominal RBW shall be in the range of 1% to 5% of the anticipated OBW, and the VBW shall be set  $\geq 3 \times$  RBW.
- c. Set the reference level of the instrument as required to prevent the signal amplitude from exceeding the maximum spectrum analyzer input mixer level for linear operation. See guidance provided in 4.2.3.
- d. The dynamic range of the spectrum analyzer at the selected RBW shall be more than 10 dB below the target “-X dB” requirement, i.e., if the requirement calls for measuring the -26 dB OBW, the spectrum analyzer noise floor at the selected RBW shall be at least 36 dB below the reference level.
- e. Set spectrum analyzer detection mode to peak, and the trace mode to max hold.
- f. Determine the following reference values: Set the EUT to transmit a modulated signal. Allow the trace to stabilize. Set the spectrum analyzer marker to the highest level of the displayed trace (this is the reference value).
- g. Determine the “-X dB amplitude” as equal to (Reference Value - X). Alternatively, this calculation can be performed on the spectrum analyzer using the delta-marker measurement function.
- h. Place two markers, one at the lowest and the other at the highest frequency of the envelope of the spectral display such that each marker is at or slightly below the “-X dB amplitude” determined in step f). If a marker is below this “-X dB amplitude” value it should be as close as possible to this value. The OBW is the positive frequency difference between the two markers.
- i. The OBW shall be reported by providing plot(s) of the measuring instrument display, to include markers depicting the relevant frequency and amplitude information (e.g., marker table). The frequency and amplitude axis and scale shall be clearly labeled. Tabular data may be reported in addition to the plot(s).

For the occupied bandwidth measurement method, please refer to section 5.4.4 of ANSI C63.26.

- a. The spectrum analyzer center frequency is set to the nominal EUT channel center frequency. The span range for the spectrum analyzer shall be wide enough to see sufficient roll off of the signal to make the measurement.
- b. The nominal RBW shall be in the range of 1% to 5% of the anticipated OBW, and the VBW shall be set  $\geq 3 \times$  RBW.
- c. Set the reference level of the instrument as required to prevent the signal amplitude from exceeding the maximum spectrum analyzer input mixer level for linear operation. See guidance provided in 4.2.3.
- d. The dynamic range of the spectrum analyzer at the selected RBW shall be more than 10 dB below the target “-X dB” requirement, i.e., if the requirement calls for measuring the -26 dB OBW, the spectrum analyzer noise floor at the selected RBW shall be at least 36 dB below the reference level.
- e. Set spectrum analyzer detection mode to peak, and the trace mode to max hold.
- f. Determine the reference value by either of the following:
  - g. 1) Set the EUT to transmit a modulated signal. Allow the trace to stabilize. Set the spectrum analyzer marker to the highest level of the displayed trace (this is the reference value).
  - h. 2) Set the EUT to transmit an unmodulated carrier. Set the spectrum analyzer marker to the level of the carrier.
- i. Determine the “-X dB amplitude” as equal to (Reference Value - X). Alternatively, this calculation can be performed on the spectrum analyzer using the delta-marker measurement function.
- j. If the reference value was determined using an unmodulated carrier, turn the EUT modulation on, then either clear the existing trace or start a new trace on the spectrum analyzer and allow the new trace to stabilize. Otherwise the trace from step f) shall be used for step i).
- k. Place two markers, one at the lowest and the other at the highest frequency of the envelope of the spectral display such that each marker is at or slightly below the “-X dB amplitude” determined in step f). If a marker is below this “-X dB amplitude” value it should be as close as possible to this value. The OBW is the positive frequency difference between the two markers. The spectral envelope can cross the “-X dB amplitude” at multiple points. The lowest or highest frequency shall be selected as the frequencies that are the farthest away from the center frequency at which the spectral envelope crosses the “-X dB amplitude.”
- l. The OBW shall be reported by providing plot(s) of the measuring instrument display, to include markers depicting the relevant frequency and amplitude information (e.g., marker table). The frequency and amplitude axis and scale shall be clearly labeled. Tabular data may be reported in addition to the plot(s).

## 6.5 Conducted Spurious Emissions

### 6.5.1 Test Setup

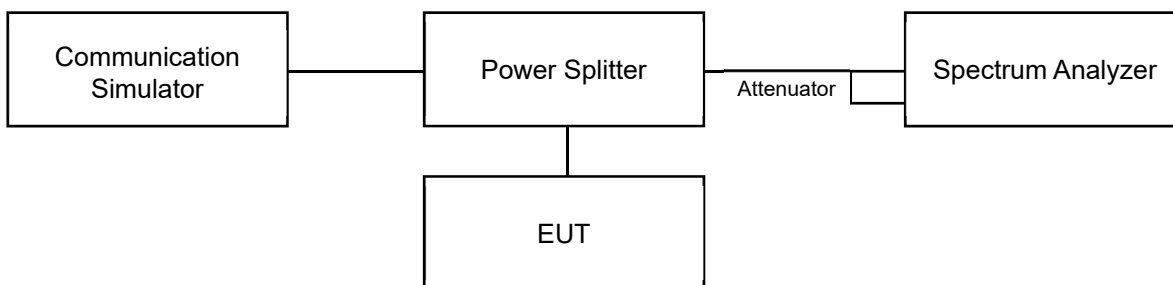

### 6.5.2 Test Procedure

- a. Measurement refer to ANSI C63.26 section 5.7.
- b. All measurements were done at 3 channels: low, middle and high operational frequency range.
- c. Measuring frequency range is from 9 kHz up to the tenth harmonic of the highest fundamental frequency or to 40 GHz, whichever is lower. 20 dB attenuation pad is connected with spectrum.
- d. The fundamental frequency above 1 GHz, the spectrum set RBW = 1 MHz, VBW = 3 MHz, Detector = Average.
- e. The fundamental frequency below 1 GHz, the spectrum set RBW  $\geq$  100 kHz, VBW  $\geq$  3 x RBW, Detector = Average.
- f. Measuring frequency band edge, narrow RBW (no less than 1% of the OBW) is used for conducted emission measurement.

## 6.6 Radiated Spurious Emissions below 1GHz

### 6.6.1 Test Setup

#### For radiated emission 30 MHz to 1 GHz

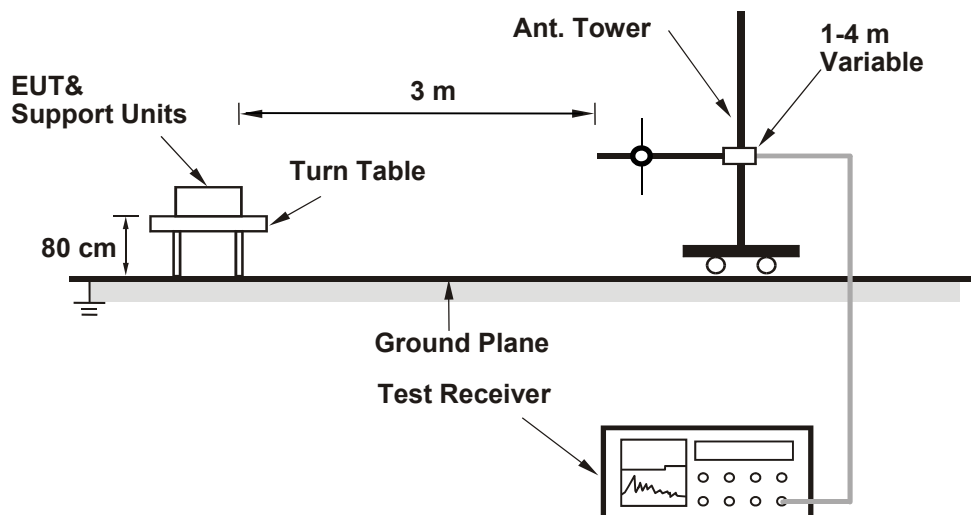

For the actual test configuration, please refer to the attached file (Test Setup Photo).

### 6.6.2 Test Procedure

The EUT is configured by emulator to set data modulation and maximum power using WWAN technology.

- a. In the semi-anechoic chamber, EUT placed on the 0.8 m (below or equal 1 GHz) height of turn table, rotated the table around 360 degrees to search the maximum radiation power and receiver antenna shall be rotated vertical and horizontal polarization and moved height from 1 m to 4 m to find the maximum polar radiated power. The "Read Value" is the spectrum reading the maximum power value.
- b. The height of antenna is varied from one meter to four meters above the ground to determine the maximum value of the field strength. Both horizontal and vertical polarizations of the antenna are set to make the measurement.
- c. Perform a field strength measurement and record the worse read value, is the field strength value via a spectrum reading obtained corrected for antenna factor, cable loss and pre-amplifier factor and then mathematically convert the measured field strength level to EIRP/ERP level.
- d. Following ANSI C63.26 section 5.5 and 5.2.7
- e.  $EIRP (dBm) = E (dB\mu V/m) + 20\log(D) - 104.8$ ; where D is the measurement distance (in the far field region) in m.
- f.  $ERP (dBm) = E (dB\mu V/m) + 20\log(D) - 104.8 - 2.15$ ; where D is the measurement distance (in the far field region) in m.

#### Note:

1. The resolution bandwidth and video bandwidth of test receiver/spectrum analyzer is 1 MHz/3 MHz. Set detector = average.

## 6.7 Radiated Spurious Emissions above 1GHz

### 6.7.1 Test Setup

#### For radiated emission above 1 GHz

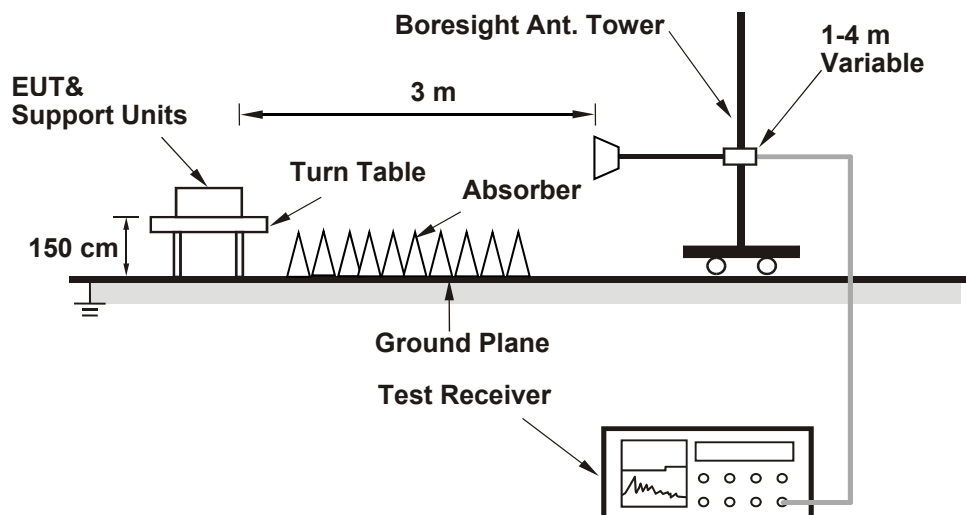

For the actual test configuration, please refer to the attached file (Test Setup Photo).

### 6.7.2 Test Procedure

The EUT is configured by emulator to set data modulation and maximum power using WWAN technology.

- In the semi-anechoic chamber, EUT placed on the 1.5 m height of turn table, rotated the table around 360 degrees to search the maximum radiation power and receiver antenna shall be rotated vertical and horizontal polarization and moved height from 1 m to 4 m to find the maximum polar radiated power. The "Read Value" is the spectrum reading the maximum power value.
- The height of antenna is varied from one meter to four meters above the ground to determine the maximum value of the field strength. Both horizontal and vertical polarizations of the antenna are set to make the measurement.
- Perform a field strength measurement and record the worse read value, is the field strength value via a spectrum reading obtained corrected for antenna factor, cable loss and pre-amplifier factor and then mathematically convert the measured field strength level to EIRP/ERP level.
- Following ANSI C63.26 section 5.5 and 5.2.7
- $EIRP (dBm) = E (dB\mu V/m) + 20\log(D) - 104.8$ ; where D is the measurement distance (in the far field region) in m.
- $ERP (dBm) = E (dB\mu V/m) + 20\log(D) - 104.8 - 2.15$ ; where D is the measurement distance (in the far field region) in m.

#### Note:

- The resolution bandwidth and video bandwidth of test receiver/spectrum analyzer is 1 MHz/3 MHz. Set detector = average.

## 6.8 Frequency Stability

### 6.8.1 Test Setup

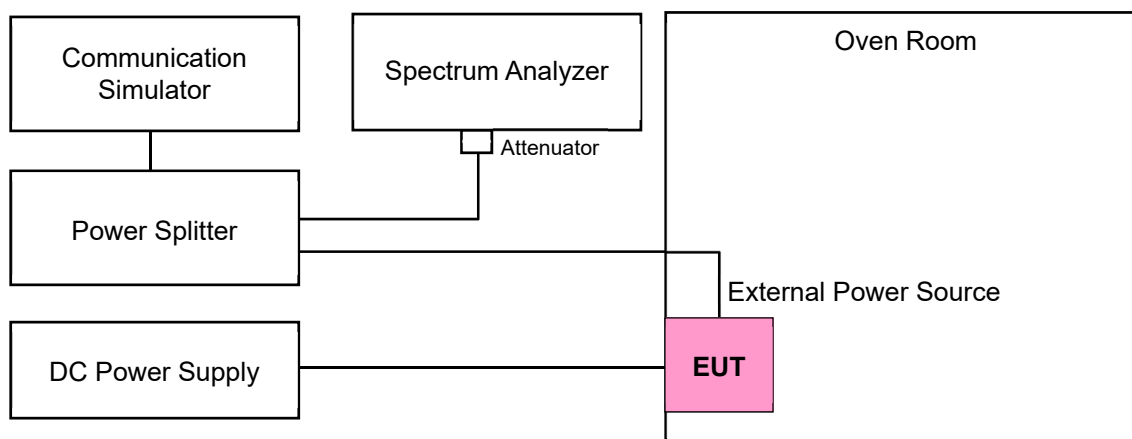

### 6.8.2 Test Procedure

The EUT is configured by emulator to set data modulation and maximum power using WWAN technology.

- Device is placed at the oven room. The oven room could control the temperatures and humidity. Power warm up is at least 15 min and power applied should perform before recording frequency error.
- EUT is connected the external power supply to control the DC input power. The test voltage range is from minimum to maximum working voltage. Each step shall be record the frequency error rate.
- The temperature range step is 10 degrees in this test items. All temperature levels shall be hold the  $\pm 0.5^{\circ}\text{C}$  during the measurement testing. The each temperature step shall be at least 0.5 hours, consider the EUT could be test under the stability condition.

Note: The frequency error was recorded frequency error from the communication simulator.

## 7 Test Results of Test Item

### 7.1 Effective Radiated Power and Equivalent Isotropically Radiated Power

Input Power:	120 Vac, 60 Hz	Environmental Conditions:	21°C, 71% RH	Tested By:	Willy Cheng
--------------	----------------	---------------------------	--------------	------------	-------------

#### Mode A

#### 7.1.1 LTE Band 2

#### LTE Band 2, Channel Bandwidth: 1.4 MHz

Modulation	RB Size	RB Offset	Measurement Conducted Power (dBm)		
			CH 18607	CH 18900	CH 19193
			1850.7 MHz	1880 MHz	1909.3 MHz
QPSK	1	0	23.73	23.65	23.72
	1	2	23.65	23.69	23.69
	1	5	23.65	23.85	23.71
	3	0	23.63	23.7	23.65
	3	1	23.7	23.7	23.6
	3	3	23.68	23.67	23.67
	6	0	22.66	22.7	22.65
16QAM	1	0	23.07	22.83	22.41
	1	2	23.01	22.7	22.7
	1	5	23.15	22.72	22.69
	3	0	22.53	22.64	22.78
	3	1	22.69	22.77	22.8
	3	3	22.6	22.56	22.63
	6	0	21.48	21.92	21.81
64QAM	1	0	21.8	21.85	21.92
	1	2	21.72	21.92	21.94
	1	5	21.91	22.09	21.58
	3	0	21.63	21.86	21.8
	3	1	21.8	21.98	21.68
	3	3	21.69	21.44	22
	6	0	20.64	20.58	20.73
256QAM	1	0	18.56	18.53	18.9
	1	2	18.68	18.4	18.6
	1	5	18.66	19.02	18.67
	3	0	18.72	18.7	18.68
	3	1	18.53	18.78	18.58
	3	3	18.69	18.56	18.63
	6	0	18.59	18.76	18.53





Maximum Output Power			
Modulation	Cond. Power (dBm)	EIRP (dBm)	EIRP Limit (dBm)
QPSK	23.85	24.85	30
16QAM	23.15	24.15	30
64QAM	22.09	23.09	30
256QAM	19.02	20.02	30

Note: EIRP (dBm) = Cond. Power (dBm) + Antenna Gain (dBi) + Array Gain (if applicable)

### LTE Band 2, Channel Bandwidth: 3 MHz

Modulation	RB Size	RB Offset	Measurement Conducted Power (dBm)		
			CH 18615	CH 18900	CH 19185
			1851.5 MHz	1880 MHz	1908.5 MHz
QPSK	1	0	23.57	23.75	23.66
	1	7	23.56	23.76	23.76
	1	14	23.65	23.66	23.54
	8	0	22.64	22.71	22.82
	8	3	22.7	22.72	22.75
	8	7	22.66	22.75	22.77
	15	0	22.62	22.65	22.73
16QAM	1	0	23.11	23.13	23.02
	1	7	22.72	22.71	23.3
	1	14	22.59	22.96	23.12
	8	0	21.7	21.81	21.78
	8	3	21.6	21.71	21.77
	8	7	21.59	21.77	21.64
	15	0	21.54	21.78	21.76
64QAM	1	0	21.58	21.92	22.03
	1	7	21.66	21.6	21.73
	1	14	21.56	21.81	21.76
	8	0	20.59	20.77	20.91
	8	3	20.55	20.71	20.75
	8	7	20.58	20.66	20.66
	15	0	20.75	20.73	20.85
256QAM	1	0	18.87	18.51	19.02
	1	7	18.47	19.07	19.16
	1	14	18.64	18.9	18.4
	8	0	18.53	18.66	18.71
	8	3	18.59	18.59	18.62
	8	7	18.49	18.54	18.56
	15	0	18.57	18.56	18.6



Maximum Output Power			
Modulation	Cond. Power (dBm)	EIRP (dBm)	EIRP Limit (dBm)
QPSK	23.76	24.76	30
16QAM	23.3	24.3	30
64QAM	22.03	23.03	30
256QAM	19.16	20.16	30

Note: EIRP (dBm) = Cond. Power (dBm) + Antenna Gain (dBi) + Array Gain (if applicable)

### LTE Band 2, Channel Bandwidth: 5 MHz

Modulation	RB Size	RB Offset	Measurement Conducted Power (dBm)		
			CH 18625	CH 18900	CH 19175
			1852.5 MHz	1880 MHz	1907.5 MHz
QPSK	1	0	23.69	23.75	23.84
	1	12	23.7	23.85	23.82
	1	24	23.72	23.85	23.66
	12	0	22.68	22.73	22.78
	12	6	22.67	22.71	22.72
	12	13	22.55	22.71	22.65
	25	0	22.66	22.74	22.75
16QAM	1	0	23.17	22.92	22.82
	1	12	22.85	22.81	22.92
	1	24	23.39	22.84	23.08
	12	0	21.77	21.8	21.86
	12	6	21.59	21.73	21.72
	12	13	21.63	21.53	21.65
	25	0	21.63	22.68	21.81
64QAM	1	0	21.62	22.01	21.93
	1	12	21.89	21.73	21.6
	1	24	21.64	21.93	21.98
	12	0	20.57	20.76	20.87
	12	6	20.71	20.88	20.79
	12	13	20.6	20.6	20.6
	25	0	20.64	20.7	20.75
256QAM	1	0	18.55	19.03	18.57
	1	12	18.5	18.78	18.86
	1	24	18.65	18.5	18.7
	12	0	18.55	18.69	18.8
	12	6	18.57	18.75	19
	12	13	18.5	18.55	18.62
	25	0	18.56	18.56	18.7



Maximum Output Power			
Modulation	Cond. Power (dBm)	EIRP (dBm)	EIRP Limit (dBm)
QPSK	23.85	24.85	30
16QAM	23.39	24.39	30
64QAM	22.01	23.01	30
256QAM	19.03	20.03	30

Note: EIRP (dBm) = Cond. Power (dBm) + Antenna Gain (dBi) + Array Gain (if applicable)

**LTE Band 2, Channel Bandwidth: 10 MHz**

Modulation	RB Size	RB Offset	Measurement Conducted Power (dBm)		
			CH 18650	CH 18900	CH 19150
			1855 MHz	1880 MHz	1905 MHz
QPSK	1	0	23.67	23.85	23.74
	1	24	23.53	23.64	23.89
	1	49	23.62	23.87	23.64
	25	0	22.74	22.77	22.87
	25	12	22.64	22.68	22.77
	25	25	22.63	22.6	22.66
	50	0	22.71	22.75	22.81
16QAM	1	0	22.61	23.21	22.68
	1	24	22.75	23.58	22.94
	1	49	22.9	22.87	23.16
	25	0	21.62	21.69	21.85
	25	12	21.67	21.78	21.71
	25	25	21.63	21.6	21.6
	50	0	21.68	21.78	21.73
64QAM	1	0	21.58	21.9	21.71
	1	24	21.67	22.02	21.67
	1	49	21.94	21.9	21.68
	25	0	20.71	20.71	20.84
	25	12	20.64	20.75	20.74
	25	25	20.72	20.73	20.73
	50	0	20.75	20.72	20.74
256QAM	1	0	18.94	18.7	18.97
	1	24	18.6	18.85	19.05
	1	49	18.94	18.87	18.57
	25	0	18.68	18.78	18.81
	25	12	18.65	18.64	18.56
	25	25	18.6	18.5	18.56
	50	0	18.62	18.65	18.75



Maximum Output Power			
Modulation	Cond. Power (dBm)	EIRP (dBm)	EIRP Limit (dBm)
QPSK	23.89	24.89	30
16QAM	23.58	24.58	30
64QAM	22.02	23.02	30
256QAM	19.05	20.05	30

Note: EIRP (dBm) = Cond. Power (dBm) + Antenna Gain (dBi) + Array Gain (if applicable)

**LTE Band 2, Channel Bandwidth: 15 MHz**

Modulation	RB Size	RB Offset	Measurement Conducted Power (dBm)		
			CH 18675	CH 18900	CH 19125
			1857.5 MHz	1880 MHz	1902.5 MHz
QPSK	1	0	23.51	23.65	23.79
	1	37	23.69	23.71	23.78
	1	74	23.75	23.73	23.73
	36	0	22.6	22.77	22.65
	36	19	22.68	22.75	22.67
	36	39	22.67	22.64	22.6
	75	0	22.72	22.76	22.63
16QAM	1	0	23.32	22.86	22.72
	1	37	23.57	23.61	22.81
	1	74	22.92	23.55	23
	36	0	21.61	21.68	21.58
	36	19	21.72	21.75	21.75
	36	39	21.57	21.66	21.65
	75	0	21.75	21.78	21.64
64QAM	1	0	21.76	21.76	21.81
	1	37	22.19	21.54	21.92
	1	74	21.88	21.91	21.91
	36	0	20.72	20.75	20.61
	36	19	20.64	20.68	20.74
	36	39	20.72	20.66	20.64
	75	0	20.66	20.62	20.65
256QAM	1	0	18.78	18.77	18.61
	1	37	19.1	19.2	18.58
	1	74	18.91	18.98	19
	36	0	18.54	18.64	18.52
	36	19	18.54	18.64	18.63
	36	39	18.55	18.67	18.56
	75	0	18.62	18.72	18.54





Maximum Output Power			
Modulation	Cond. Power (dBm)	EIRP (dBm)	EIRP Limit (dBm)
QPSK	23.79	24.79	30
16QAM	23.61	24.61	30
64QAM	22.19	23.19	30
256QAM	19.2	20.2	30

Note: EIRP (dBm) = Cond. Power (dBm) + Antenna Gain (dBi) + Array Gain (if applicable)

### LTE Band 2, Channel Bandwidth: 20 MHz

Modulation	RB Size	RB Offset	Measurement Conducted Power (dBm)		
			CH 18700	CH 18900	CH 19100
			1860 MHz	1880 MHz	1900 MHz
QPSK	1	0	23.6	23.92	23.63
	1	50	23.6	23.87	23.79
	1	99	23.62	23.81	23.79
	50	0	22.78	22.82	22.58
	50	25	22.76	22.72	22.75
	50	50	22.76	22.61	22.58
	100	0	22.89	22.65	22.62
16QAM	1	0	22.96	22.51	22.88
	1	50	23.3	22.92	22.99
	1	99	22.73	23.37	23.03
	50	0	21.78	21.76	21.6
	50	25	21.72	21.73	21.81
	50	50	21.8	21.68	21.41
	100	0	21.81	21.63	21.65
64QAM	1	0	21.91	21.71	22.17
	1	50	21.36	22.21	22.18
	1	99	21.66	21.93	21.97
	50	0	20.82	20.69	20.56
	50	25	20.64	20.73	20.7
	50	50	20.72	20.53	20.54
	100	0	20.73	20.56	20.47
256QAM	1	0	18.4	18.34	18.45
	1	50	18.97	18.62	18.95
	1	99	18.52	18.62	18.95
	50	0	18.74	18.7	18.55
	50	25	18.55	18.7	18.65
	50	50	18.7	18.53	18.37
	100	0	18.72	18.52	18.41



Maximum Output Power			
Modulation	Cond. Power (dBm)	EIRP (dBm)	EIRP Limit (dBm)
QPSK	23.92	24.92	30
16QAM	23.37	24.37	30
64QAM	22.21	23.21	30
256QAM	18.97	19.97	30

Note: EIRP (dBm) = Cond. Power (dBm) + Antenna Gain (dBi) + Array Gain (if applicable)

### 7.1.2 LTE Band 4

#### LTE Band 4, Channel Bandwidth: 1.4 MHz

Modulation	RB Size	RB Offset	Measurement Conducted Power (dBm)		
			CH 19957	CH 20175	CH 20393
			1710.7 MHz	1732.5 MHz	1754.3 MHz
QPSK	1	0	23.72	23.66	23.72
	1	2	23.78	23.9	23.88
	1	5	23.6	23.67	23.63
	3	0	23.82	23.76	23.71
	3	1	23.78	23.75	23.73
	3	3	23.73	23.61	23.74
	6	0	22.64	22.67	22.66
16QAM	1	0	22.81	22.88	22.65
	1	2	22.62	22.9	22.76
	1	5	22.56	23.48	22.82
	3	0	22.69	22.75	22.67
	3	1	22.82	22.67	22.58
	3	3	22.58	22.77	22.78
	6	0	21.76	21.55	21.68
64QAM	1	0	22.03	21.74	21.96
	1	2	21.71	21.67	22.06
	1	5	21.45	21.64	21.8
	3	0	21.62	21.89	21.69
	3	1	21.66	21.73	21.89
	3	3	21.93	21.52	21.8
	6	0	20.85	20.85	20.61
256QAM	1	0	18.57	18.87	18.48
	1	2	18.34	18.63	18.78
	1	5	18.97	18.84	18.53
	3	0	18.57	18.48	18.81
	3	1	18.95	18.76	18.59
	3	3	18.66	18.55	18.69
	6	0	18.74	18.6	18.74



Maximum Output Power			
Modulation	Cond. Power (dBm)	EIRP (dBm)	EIRP Limit (dBm)
QPSK	23.9	24.9	30
16QAM	23.48	24.48	30
64QAM	22.06	23.06	30
256QAM	18.97	19.97	30

Note: EIRP (dBm) = Cond. Power (dBm) + Antenna Gain (dBi) + Array Gain (if applicable)

### LTE Band 4, Channel Bandwidth: 3 MHz

Modulation	RB Size	RB Offset	Measurement Conducted Power (dBm)		
			CH 19965	CH 20175	CH 20385
			1711.5 MHz	1732.5 MHz	1753.5 MHz
QPSK	1	0	23.6	23.65	23.75
	1	7	23.73	23.76	23.76
	1	14	23.59	23.65	23.68
	8	0	22.84	22.72	22.73
	8	3	22.7	22.69	22.75
	8	7	22.79	22.73	22.73
	15	0	22.83	22.73	22.69
16QAM	1	0	22.81	22.79	22.84
	1	7	23.04	22.87	22.76
	1	14	23.16	22.67	23.06
	8	0	21.78	21.87	21.98
	8	3	21.68	21.78	21.71
	8	7	21.88	21.85	21.78
	15	0	21.73	21.65	21.71
64QAM	1	0	21.75	21.72	22.13
	1	7	21.7	21.93	22.07
	1	14	21.99	21.63	21.96
	8	0	20.65	20.9	20.67
	8	3	20.77	20.64	20.62
	8	7	20.99	20.64	20.68
	15	0	20.67	20.69	20.7
256QAM	1	0	18.98	19.16	19.01
	1	7	19.17	19.15	18.98
	1	14	19.11	19	18.94
	8	0	18.69	18.76	18.6
	8	3	18.65	18.79	18.73
	8	7	18.61	18.59	18.63
	15	0	18.72	18.84	18.73



Maximum Output Power			
Modulation	Cond. Power (dBm)	EIRP (dBm)	EIRP Limit (dBm)
QPSK	23.76	24.76	30
16QAM	23.16	24.16	30
64QAM	22.13	23.13	30
256QAM	19.17	20.17	30

Note: EIRP (dBm) = Cond. Power (dBm) + Antenna Gain (dBi) + Array Gain (if applicable)

### LTE Band 4, Channel Bandwidth: 5 MHz

Modulation	RB Size	RB Offset	Measurement Conducted Power (dBm)		
			CH 19975	CH 20175	CH 20375
			1712.5 MHz	1732.5 MHz	1752.5 MHz
QPSK	1	0	23.67	23.76	23.63
	1	12	23.72	23.82	23.63
	1	24	23.8	23.73	23.69
	12	0	22.74	22.68	22.66
	12	6	22.68	22.72	22.79
	12	13	22.66	22.7	22.79
	25	0	22.82	22.74	22.78
16QAM	1	0	22.74	23.29	22.99
	1	12	23.43	22.61	22.64
	1	24	22.55	23.13	22.81
	12	0	21.7	21.68	21.56
	12	6	21.77	21.79	21.62
	12	13	21.7	21.62	21.71
	25	0	21.8	22.65	21.73
64QAM	1	0	21.6	21.71	21.88
	1	12	21.97	22.26	21.84
	1	24	21.74	21.91	21.67
	12	0	20.78	20.76	20.87
	12	6	20.66	20.76	20.87
	12	13	20.82	20.69	20.88
	25	0	20.75	20.69	20.69
256QAM	1	0	18.62	18.32	18.65
	1	12	19.18	18.51	18.88
	1	24	18.6	18.71	18.93
	12	0	18.62	18.63	18.7
	12	6	18.56	18.62	18.58
	12	13	18.57	18.62	18.57
	25	0	18.72	18.75	18.62





Maximum Output Power			
Modulation	Cond. Power (dBm)	EIRP (dBm)	EIRP Limit (dBm)
QPSK	23.82	24.82	30
16QAM	23.43	24.43	30
64QAM	22.26	23.26	30
256QAM	19.18	20.18	30

Note: EIRP (dBm) = Cond. Power (dBm) + Antenna Gain (dBi) + Array Gain (if applicable)

**LTE Band 4, Channel Bandwidth: 10 MHz**

Modulation	RB Size	RB Offset	Measurement Conducted Power (dBm)		
			CH 20000	CH 20175	CH 20350
			1715 MHz	1732.5 MHz	1750 MHz
QPSK	1	0	23.61	23.54	23.72
	1	24	23.56	23.6	23.69
	1	49	23.67	23.83	23.7
	25	0	22.69	22.77	22.77
	25	12	22.7	22.78	22.7
	25	25	22.76	22.73	22.87
	50	0	22.81	22.67	22.84
16QAM	1	0	22.98	22.99	23.01
	1	24	23.3	23.22	22.52
	1	49	22.95	22.97	22.98
	25	0	21.67	21.66	21.64
	25	12	21.72	21.73	21.75
	25	25	21.73	21.63	21.7
	50	0	21.83	21.6	21.73
64QAM	1	0	21.74	21.67	21.42
	1	24	21.74	22.16	21.59
	1	49	21.78	22.05	21.61
	25	0	20.62	20.74	20.8
	25	12	20.66	20.72	20.63
	25	25	20.71	20.71	20.72
	50	0	20.73	20.65	20.7
256QAM	1	0	18.84	18.62	19.1
	1	24	18.69	18.56	18.97
	1	49	18.45	19.4	18.82
	25	0	18.59	18.64	18.74
	25	12	18.68	18.63	18.73
	25	25	18.73	18.68	18.73
	50	0	18.7	18.57	18.65



Maximum Output Power			
Modulation	Cond. Power (dBm)	EIRP (dBm)	EIRP Limit (dBm)
QPSK	23.83	24.83	30
16QAM	23.3	24.3	30
64QAM	22.16	23.16	30
256QAM	19.4	20.4	30

Note: EIRP (dBm) = Cond. Power (dBm) + Antenna Gain (dBi) + Array Gain (if applicable)

**LTE Band 4, Channel Bandwidth: 15 MHz**

Modulation	RB Size	RB Offset	Measurement Conducted Power (dBm)		
			CH 20025	CH 20175	CH 20325
			1717.5 MHz	1732.5 MHz	1747.5 MHz
QPSK	1	0	23.62	23.87	23.8
	1	37	23.73	23.62	23.73
	1	74	23.71	23.78	23.72
	36	0	22.68	22.73	22.78
	36	19	22.69	22.76	22.76
	36	39	22.8	22.76	22.73
	75	0	22.75	22.73	22.8
16QAM	1	0	22.65	22.92	22.77
	1	37	23.11	23.25	22.82
	1	74	22.53	22.86	23.06
	36	0	21.74	21.59	21.71
	36	19	21.66	21.65	21.67
	36	39	21.77	21.63	21.83
	75	0	21.8	21.8	21.76
64QAM	1	0	21.66	21.97	21.66
	1	37	21.68	21.75	21.87
	1	74	22.06	21.85	21.8
	36	0	20.71	20.63	20.69
	36	19	20.66	20.66	20.74
	36	39	20.87	20.69	20.78
	75	0	20.67	20.71	20.66
256QAM	1	0	18.42	18.48	18.61
	1	37	19.12	18.73	18.76
	1	74	18.99	18.48	19.09
	36	0	18.55	18.59	18.73
	36	19	18.67	18.61	18.71
	36	39	18.73	18.73	18.72
	75	0	18.66	18.76	18.71



Maximum Output Power			
Modulation	Cond. Power (dBm)	EIRP (dBm)	EIRP Limit (dBm)
QPSK	23.87	24.87	30
16QAM	23.25	24.25	30
64QAM	22.06	23.06	30
256QAM	19.12	20.12	30

Note: EIRP (dBm) = Cond. Power (dBm) + Antenna Gain (dBi) + Array Gain (if applicable)

**LTE Band 4, Channel Bandwidth: 20 MHz**

Modulation	RB Size	RB Offset	Measurement Conducted Power (dBm)		
			CH 20050	CH 20175	CH 20300
			1720 MHz	1732.5 MHz	1745 MHz
QPSK	1	0	23.7	24.01	23.8
	1	50	23.61	23.81	23.67
	1	99	23.98	23.76	23.75
	50	0	22.62	22.76	22.88
	50	25	22.77	22.78	22.72
	50	50	22.99	22.67	22.8
	100	0	22.78	22.65	22.77
16QAM	1	0	23.23	22.77	22.83
	1	50	23.06	22.77	23.01
	1	99	23.42	22.9	22.89
	50	0	21.62	21.7	21.84
	50	25	21.79	21.8	21.71
	50	50	21.88	21.72	21.79
	100	0	21.78	21.71	21.76
64QAM	1	0	21.34	22.12	21.92
	1	50	21.87	21.89	21.94
	1	99	21.74	21.92	22.01
	50	0	20.55	20.64	20.79
	50	25	20.83	20.78	20.76
	50	50	20.86	20.69	20.85
	100	0	20.71	20.58	20.86
256QAM	1	0	19.15	19.13	18.55
	1	50	18.79	18.71	18.38
	1	99	18.77	19.16	18.95
	50	0	18.63	18.62	18.69
	50	25	18.8	18.65	18.72
	50	50	18.83	18.64	18.8
	100	0	18.77	18.5	18.78



Maximum Output Power			
Modulation	Cond. Power (dBm)	EIRP (dBm)	EIRP Limit (dBm)
QPSK	24.01	25.01	30
16QAM	23.42	24.42	30
64QAM	22.12	23.12	30
256QAM	19.16	20.16	30

Note: EIRP (dBm) = Cond. Power (dBm) + Antenna Gain (dBi) + Array Gain (if applicable)

### 7.1.3 LTE Band 5

#### LTE Band 5, Channel Bandwidth: 1.4 MHz

Modulation	RB Size	RB Offset	Measurement Conducted Power (dBm)		
			CH 20407	CH 20525	CH 20643
			824.7 MHz	836.5 MHz	848.3 MHz
QPSK	1	0	23.92	23.84	23.78
	1	2	23.93	24.07	23.86
	1	5	24.03	23.78	23.91
	3	0	23.86	23.92	23.81
	3	1	24.02	23.93	23.77
	3	3	24.02	23.94	23.89
	6	0	22.96	22.93	22.82
16QAM	1	0	22.97	23.08	23.49
	1	2	23.4	22.95	23.24
	1	5	23.33	22.92	22.97
	3	0	22.92	22.81	22.98
	3	1	22.86	22.84	22.72
	3	3	22.78	22.97	23.09
	6	0	22.05	21.84	21.93
64QAM	1	0	22.12	22.01	22.06
	1	2	22.21	22.11	22.02
	1	5	22.24	21.93	21.92
	3	0	21.78	22.08	21.89
	3	1	22.01	21.94	21.92
	3	3	21.88	21.85	21.77
	6	0	20.83	20.91	20.8
256QAM	1	0	19.42	19.74	19.32
	1	2	19.63	19.27	19.36
	1	5	18.94	19.11	18.93
	3	0	19.32	19.56	18.92
	3	1	19.41	19.28	18.98
	3	3	19.17	19.08	19.1
	6	0	19.32	19.04	19.05





Maximum Output Power

Modulation	Cond. Power (dBm)	ERP (dBm)	ERP Limit (dBm)
QPSK	24.07	22.82	30
16QAM	23.49	22.24	30
64QAM	22.24	20.99	30
256QAM	19.74	18.49	30

Note: EIRP (dBm) = Cond. Power (dBm) + Antenna Gain (dBi) + Array Gain (if applicable)

ERP (dBm) = EIRP (dBm) - 2.15

### LTE Band 5, Channel Bandwidth: 3 MHz

Modulation	RB Size	RB Offset	Measurement Conducted Power (dBm)		
			CH 20415	CH 20525	CH 20635
			825.5 MHz	836.5 MHz	847.5 MHz
QPSK	1	0	23.94	23.83	23.79
	1	7	23.83	23.81	23.85
	1	14	24.04	23.83	23.82
	8	0	22.99	22.95	22.92
	8	3	22.93	22.95	22.91
	8	7	22.96	22.79	22.8
	15	0	22.93	22.95	22.87
16QAM	1	0	22.95	22.8	22.99
	1	7	23.09	22.82	23.18
	1	14	23	23.24	23
	8	0	21.88	21.93	22
	8	3	21.91	21.89	21.85
	8	7	22.07	21.93	21.86
	15	0	21.86	21.86	22
64QAM	1	0	22.02	22.08	22.16
	1	7	22.09	22.15	21.57
	1	14	21.97	21.85	22.42
	8	0	21.03	20.88	20.72
	8	3	20.7	20.91	20.68
	8	7	21.02	20.9	20.79
	15	0	20.79	20.79	20.78
256QAM	1	0	19.27	19.35	19.04
	1	7	19.47	19.24	19.33
	1	14	19.24	19.2	19.29
	8	0	19.28	19.26	19.05
	8	3	19.28	19.01	19.17
	8	7	19.08	19.15	19.06
	15	0	19.24	19.26	19.26



Maximum Output Power			
Modulation	Cond. Power (dBm)	ERP (dBm)	ERP Limit (dBm)
QPSK	24.04	22.79	30
16QAM	23.24	21.99	30
64QAM	22.42	21.17	30
256QAM	19.47	18.22	30

Note: EIRP (dBm) = Cond. Power (dBm) + Antenna Gain (dBi) + Array Gain (if applicable)

ERP (dBm) = EIRP (dBm) - 2.15

**LTE Band 5, Channel Bandwidth: 5 MHz**

Modulation	RB Size	RB Offset	Measurement Conducted Power (dBm)		
			CH 20425	CH 20525	CH 20625
			826.5 MHz	836.5 MHz	846.5 MHz
QPSK	1	0	24.12	24.03	23.97
	1	12	23.84	23.91	23.88
	1	24	24.11	23.79	23.88
	12	0	22.89	23.01	23
	12	6	23.03	22.89	22.87
	12	13	23.04	22.82	22.69
	25	0	23.02	22.88	22.86
16QAM	1	0	23.25	22.98	23.02
	1	12	22.83	22.99	23.07
	1	24	23.12	23.06	22.94
	12	0	21.95	21.97	22
	12	6	21.88	21.84	21.92
	12	13	22.04	21.72	21.88
	25	0	21.97	22.73	21.94
64QAM	1	0	21.89	22.17	21.94
	1	12	22.11	21.6	21.9
	1	24	22.16	21.86	21.85
	12	0	20.88	21.07	20.96
	12	6	20.87	20.96	20.88
	12	13	20.9	20.8	20.53
	25	0	21.09	20.74	20.63
256QAM	1	0	19.22	19.31	19.2
	1	12	19.2	19.36	19.39
	1	24	19.77	19.15	19.08
	12	0	19.2	19.39	19.33
	12	6	19.25	19.16	19.12
	12	13	19.36	18.97	18.81
	25	0	19.17	19.21	19.15



Maximum Output Power

Modulation	Cond. Power (dBm)	ERP (dBm)	ERP Limit (dBm)
QPSK	24.12	22.87	30
16QAM	23.25	22	30
64QAM	22.17	20.92	30
256QAM	19.77	18.52	30

Note: EIRP (dBm) = Cond. Power (dBm) + Antenna Gain (dBi) + Array Gain (if applicable)

ERP (dBm) = EIRP (dBm) - 2.15

**LTE Band 5, Channel Bandwidth: 10 MHz**

Modulation	RB Size	RB Offset	Measurement Conducted Power (dBm)		
			CH 20450	CH 20525	CH 20600
			829 MHz	836.5 MHz	844 MHz
QPSK	1	0	23.94	24.21	23.94
	1	24	23.98	24.13	23.71
	1	49	23.88	24.01	23.8
	25	0	22.82	23.12	22.75
	25	12	22.95	22.92	22.87
	25	25	23.05	22.87	22.58
	50	0	23.01	23	22.7
16QAM	1	0	23.12	23.4	23.24
	1	24	23.07	23.05	23.01
	1	49	22.94	23.34	23.32
	25	0	21.82	22.12	21.74
	25	12	22.01	21.95	21.79
	25	25	22.07	21.91	21.59
	50	0	21.99	21.92	21.59
64QAM	1	0	22.37	22.24	22.21
	1	24	21.85	21.91	21.9
	1	49	21.92	21.89	22.29
	25	0	20.87	20.99	20.58
	25	12	20.79	20.76	20.75
	25	25	21.03	20.92	20.42
	50	0	20.9	20.96	20.54
256QAM	1	0	19.51	19.23	19.59
	1	24	19.12	19.52	19.52
	1	49	19.53	19.67	18.96
	25	0	19.2	19.15	18.97
	25	12	19.14	19.24	19.16
	25	25	19.38	19.03	18.74
	50	0	19.22	19.29	18.91



Maximum Output Power			
Modulation	Cond. Power (dBm)	ERP (dBm)	ERP Limit (dBm)
QPSK	24.21	22.96	30
16QAM	23.4	22.15	30
64QAM	22.37	21.12	30
256QAM	19.67	18.42	30

Note: EIRP (dBm) = Cond. Power (dBm) + Antenna Gain (dBi) + Array Gain (if applicable)

ERP (dBm) = EIRP (dBm) - 2.15

### 7.1.4 LTE Band 12

#### LTE Band 12, Channel Bandwidth: 1.4 MHz

Modulation	RB Size	RB Offset	Measurement Conducted Power (dBm)		
			CH 23017	CH 23095	CH 23173
			699.7 MHz	707.5 MHz	715.3 MHz
QPSK	1	0	23.84	24.03	24.05
	1	2	23.97	24.04	24.2
	1	5	24.09	23.94	24.11
	3	0	23.97	24	24.03
	3	1	23.98	24.01	24.11
	3	3	23.97	24.02	24.07
	6	0	22.91	23.09	23.02
16QAM	1	0	23.14	22.99	23.03
	1	2	23.21	23.34	22.95
	1	5	23.09	23.25	22.96
	3	0	23.04	23.01	22.96
	3	1	22.92	22.92	23.02
	3	3	22.9	23.14	22.99
	6	0	22.15	22.12	22.07
64QAM	1	0	22.09	22.09	22.2
	1	2	22.43	22.35	22.38
	1	5	22.23	22.48	22.21
	3	0	21.85	22.29	22.04
	3	1	22.05	22.13	22.32
	3	3	21.97	21.92	22.06
	6	0	21.18	21.47	21.36
256QAM	1	0	19.4	19.25	19.81
	1	2	19.72	19.46	19.26
	1	5	18.96	19.15	19.08
	3	0	19.49	19.18	19.17
	3	1	19.33	19.21	19.18
	3	3	19.4	19.26	19.22
	6	0	19.26	19.21	19.34





Maximum Output Power			
Modulation	Cond. Power (dBm)	ERP (dBm)	ERP Limit (dBm)
QPSK	24.2	22.95	30
16QAM	23.34	22.09	30
64QAM	22.48	21.23	30
256QAM	19.81	18.56	30

Note: EIRP (dBm) = Cond. Power (dBm) + Antenna Gain (dBi) + Array Gain (if applicable)

ERP (dBm) = EIRP (dBm) - 2.15

**LTE Band 12, Channel Bandwidth: 3 MHz**

Modulation	RB Size	RB Offset	Measurement Conducted Power (dBm)		
			CH 23025	CH 23095	CH 23165
			700.5 MHz	707.5 MHz	714.5 MHz
QPSK	1	0	23.97	23.95	23.91
	1	7	24.01	24.05	23.96
	1	14	23.97	23.81	24.03
	8	0	23.1	22.99	23.1
	8	3	22.93	22.92	23
	8	7	22.96	23.01	22.97
	15	0	23.12	22.96	23.05
16QAM	1	0	22.89	22.92	23.19
	1	7	23.09	22.88	23.82
	1	14	23.66	23.11	23.63
	8	0	22.05	22	21.96
	8	3	22.03	22.17	21.94
	8	7	21.86	21.94	21.99
	15	0	22.15	21.97	22.05
64QAM	1	0	22.36	22.12	22.22
	1	7	22.23	21.92	22.41
	1	14	22.24	22	22.15
	8	0	21.41	21.28	21.34
	8	3	21.21	21.36	21.27
	8	7	21.33	21.63	21.28
	15	0	21.37	21.26	21.4
256QAM	1	0	19.1	19.24	19.28
	1	7	19.46	19.36	19.45
	1	14	19.15	19.1	19.14
	8	0	19.37	19.3	19.29
	8	3	19.25	19.23	19.29
	8	7	19.2	19.32	19.33
	15	0	19.31	19.43	19.44



Maximum Output Power			
Modulation	Cond. Power (dBm)	ERP (dBm)	ERP Limit (dBm)
QPSK	24.05	22.8	30
16QAM	23.82	22.57	30
64QAM	22.41	21.16	30
256QAM	19.46	18.21	30

Note: EIRP (dBm) = Cond. Power (dBm) + Antenna Gain (dBi) + Array Gain (if applicable)

ERP (dBm) = EIRP (dBm) - 2.15

**LTE Band 12, Channel Bandwidth: 5 MHz**

Modulation	RB Size	RB Offset	Measurement Conducted Power (dBm)		
			CH 23035	CH 23095	CH 23155
			701.5 MHz	707.5 MHz	713.5 MHz
QPSK	1	0	24.12	24.19	24.07
	1	12	24.06	24	24.14
	1	24	24.13	24.13	24.03
	12	0	23.22	22.95	23.23
	12	6	22.98	22.96	23.15
	12	13	22.89	23.23	22.88
	25	0	23.15	23.15	23.08
16QAM	1	0	23.32	23.16	23.57
	1	12	23.77	23.27	23.21
	1	24	23.3	23.34	23.17
	12	0	22.25	21.87	22.19
	12	6	22.1	22.05	22.02
	12	13	21.86	22.17	21.89
	25	0	22.05	23.16	21.97
64QAM	1	0	22.11	22.62	22
	1	12	22.03	22.39	21.93
	1	24	22.4	22.05	22.04
	12	0	21.68	21.15	21.5
	12	6	21.53	21.34	21.43
	12	13	21.3	21.44	21.22
	25	0	21.38	21.29	21.27
256QAM	1	0	19.24	19.97	19.38
	1	12	19.21	19.35	19.38
	1	24	19.53	19.11	19.5
	12	0	19.63	19.19	19.58
	12	6	19.19	19.41	19.35
	12	13	19.21	19.53	18.95
	25	0	19.47	19.25	19.35



Maximum Output Power

Modulation	Cond. Power (dBm)	ERP (dBm)	ERP Limit (dBm)
QPSK	24.19	22.94	30
16QAM	23.77	22.52	30
64QAM	22.62	21.37	30
256QAM	19.97	18.72	30

Note: EIRP (dBm) = Cond. Power (dBm) + Antenna Gain (dBi) + Array Gain (if applicable)

ERP (dBm) = EIRP (dBm) - 2.15

**LTE Band 12, Channel Bandwidth: 10 MHz**

Modulation	RB Size	RB Offset	Measurement Conducted Power (dBm)		
			CH 23060	CH 23095	CH 23130
			704 MHz	707.5 MHz	711 MHz
QPSK	1	0	23.98	24.25	24.13
	1	24	24.06	24.17	24.17
	1	49	24.07	23.96	24.15
	25	0	23.32	22.93	22.7
	25	12	23.12	23.03	23
	25	25	23.27	23.22	22.61
	50	0	23.38	23.1	22.61
16QAM	1	0	23.54	22.84	23.29
	1	24	23.16	23.41	23.66
	1	49	23.38	23.25	22.99
	25	0	22.46	21.88	21.65
	25	12	22	22.05	22.03
	25	25	22.36	22.17	21.6
	50	0	22.39	21.98	21.62
64QAM	1	0	22.05	22.53	22.29
	1	24	22.14	22.26	22.14
	1	49	22.23	21.9	22.24
	25	0	21.74	21.31	21.03
	25	12	21.4	21.42	21.23
	25	25	21.71	21.52	20.92
	50	0	21.63	21.48	21
256QAM	1	0	19.45	19.34	19.13
	1	24	19.42	19.39	19.09
	1	49	19.49	19.37	19.23
	25	0	19.75	19.28	19.04
	25	12	19.32	19.21	19.3
	25	25	19.52	19.71	18.92
	50	0	19.3	19.43	18.95



Maximum Output Power			
Modulation	Cond. Power (dBm)	ERP (dBm)	ERP Limit (dBm)
QPSK	24.25	23	30
16QAM	23.66	22.41	30
64QAM	22.53	21.28	30
256QAM	19.75	18.5	30

Note: EIRP (dBm) = Cond. Power (dBm) + Antenna Gain (dBi) + Array Gain (if applicable)

ERP (dBm) = EIRP (dBm) - 2.15

### 7.1.5 LTE Band 14

#### LTE Band 14, Channel Bandwidth: 5 MHz

Modulation	RB Size	RB Offset	Measurement Conducted Power (dBm)		
			CH 23305	CH 23330	CH 23355
			790.5 MHz	793 MHz	795.5 MHz
QPSK	1	0	24.02	24.17	24.08
	1	12	24.10	24.12	24.11
	1	24	24.03	24.11	24.17
	12	0	23.06	23.06	22.99
	12	6	23.12	23.07	23.04
	12	13	23.01	23.02	23.00
	25	0	23.10	23.07	23.10
16QAM	1	0	23.26	23.01	23.23
	1	12	23.50	23.03	23.30
	1	24	23.10	23.01	23.09
	12	0	21.95	22.07	22.10
	12	6	22.06	22.01	22.07
	12	13	21.99	22.01	22.03
	25	0	22.11	23.05	22.11
64QAM	1	0	22.17	22.42	22.39
	1	12	21.97	22.40	22.20
	1	24	22.20	22.05	22.14
	12	0	21.46	21.54	21.45
	12	6	21.50	21.53	21.50
	12	13	21.39	21.52	21.56
	25	0	21.49	21.43	21.50
256QAM	1	0	19.74	19.39	20.00
	1	12	19.33	19.36	19.61
	1	24	19.30	19.47	19.41
	12	0	19.41	19.46	19.36
	12	6	19.34	19.32	19.43
	12	13	19.25	19.45	19.44
	25	0	19.46	19.44	19.46





Maximum Output Power			
Modulation	Cond. Power (dBm)	ERP (dBm)	ERP Limit (dBm)
QPSK	24.17	22.92	34.8
16QAM	23.50	22.25	34.8
64QAM	22.42	21.17	34.8
256QAM	20.00	18.75	34.8

Note: EIRP (dBm) = Cond. Power (dBm) + Antenna Gain (dBi) + Array Gain (if applicable)

ERP (dBm) = EIRP (dBm) - 2.15

**LTE Band 14, Channel Bandwidth: 10 MHz**

Modulation	RB Size	RB Offset	Measurement Conducted Power (dBm)
			CH 23330
			793 MHz
QPSK	1	0	24.21
	1	24	24.15
	1	49	24.12
	25	0	23.08
	25	12	23.07
	25	25	23.08
	50	0	23.11
16QAM	1	0	23.70
	1	24	23.18
	1	49	23.05
	25	0	22.14
	25	12	22.09
	25	25	22.13
	50	0	22.08
64QAM	1	0	22.30
	1	24	22.15
	1	49	21.97
	25	0	21.54
	25	12	21.50
	25	25	21.41
	50	0	21.50
256QAM	1	0	19.89
	1	24	19.44
	1	49	19.67
	25	0	19.45
	25	12	19.38
	25	25	19.45
	50	0	19.45



Maximum Output Power

Modulation	Cond. Power (dBm)	ERP (dBm)	ERP Limit (dBm)
QPSK	24.21	22.96	34.8
16QAM	23.70	22.45	34.8
64QAM	22.30	21.05	34.8
256QAM	19.89	18.64	34.8

Note: EIRP (dBm) = Cond. Power (dBm) + Antenna Gain (dBi) + Array Gain (if applicable)

ERP (dBm) = EIRP (dBm) - 2.15

7.1.6 LTE Band 30

**LTE Band 30, Channel Bandwidth: 5 MHz**

Modulation	RB Size	RB Offset	Measurement Conducted Power (dBm)		
			CH 27685	CH 27710	CH 27735
			2307.5 MHz	2310 MHz	2312.5 MHz
QPSK	1	0	23.76	23.67	23.59
	1	12	23.58	23.6	23.72
	1	24	23.74	23.54	23.7
	12	0	22.74	22.63	22.56
	12	6	22.68	22.69	22.55
	12	13	22.53	22.61	22.57
	25	0	22.7	22.62	22.66
16QAM	1	0	22.67	23.11	22.48
	1	12	22.83	22.96	22.68
	1	24	22.62	22.81	22.65
	12	0	21.7	21.73	21.56
	12	6	21.58	21.67	21.58
	12	13	21.7	21.62	21.6
	25	0	21.57	22.57	21.64
64QAM	1	0	21.77	21.5	21.81
	1	12	21.7	21.61	22.06
	1	24	21.79	21.54	21.53
	12	0	20.5	20.53	20.67
	12	6	20.67	20.47	20.57
	12	13	20.58	20.54	20.57
	25	0	20.46	20.71	20.53
256QAM	1	0	18.42	18.64	18.56
	1	12	18.3	18.34	19.15
	1	24	19.16	18.49	18.85
	12	0	18.44	18.55	18.4
	12	6	18.46	18.57	18.49
	12	13	18.35	18.49	18.29
	25	0	18.39	18.5	18.44



Maximum Output Power			
Modulation	Cond. Power (dBm)	EIRP (dBm)	EIRP Limit (dBm)
QPSK	23.76	24.76	30
16QAM	23.11	24.11	30
64QAM	22.06	23.06	30
256QAM	19.16	20.16	30

Note: EIRP (dBm) = Cond. Power (dBm) + Antenna Gain (dBi) + Array Gain (if applicable)

**LTE Band 30, Channel Bandwidth: 10 MHz**

Modulation	RB Size	RB Offset	Measurement Conducted Power (dBm)
			CH 27710
			2310 MHz
QPSK	1	0	23.81
	1	24	23.76
	1	49	23.62
	25	0	22.68
	25	12	22.57
	25	25	22.58
	50	0	22.67
16QAM	1	0	23.18
	1	24	22.62
	1	49	23.12
	25	0	21.54
	25	12	21.67
	25	25	21.66
	50	0	21.71
64QAM	1	0	21.92
	1	24	21.58
	1	49	21.4
	25	0	20.68
	25	12	20.58
	25	25	20.5
	50	0	20.59
256QAM	1	0	18.64
	1	24	18.62
	1	49	18.63
	25	0	18.52
	25	12	18.46
	25	25	18.39
	50	0	18.54



Maximum Output Power			
Modulation	Cond. Power (dBm)	EIRP (dBm)	EIRP Limit (dBm)
QPSK	23.81	24.81	30
16QAM	23.18	24.18	30
64QAM	21.92	22.92	30
256QAM	18.64	19.64	30

Note: EIRP (dBm) = Cond. Power (dBm) + Antenna Gain (dBi) + Array Gain (if applicable)

7.1.1.7 LTE Band 66

**LTE Band 66, Channel Bandwidth: 1.4 MHz**

Modulation	RB Size	RB Offset	Measurement Conducted Power (dBm)		
			CH 131979	CH 132322	CH 132665
			1710.7 MHz	1745 MHz	1779.3 MHz
QPSK	1	0	23.61	23.73	23.57
	1	2	23.69	23.78	23.73
	1	5	23.81	23.52	23.73
	3	0	23.72	23.79	23.69
	3	1	23.77	23.74	23.73
	3	3	23.76	23.73	23.74
	6	0	22.69	22.65	22.68
16QAM	1	0	22.59	23.21	23.26
	1	2	23.12	23.21	22.7
	1	5	22.71	22.97	22.97
	3	0	22.71	22.69	22.82
	3	1	22.68	22.69	22.9
	3	3	22.77	22.46	22.75
	6	0	21.72	21.76	21.83
64QAM	1	0	21.74	21.6	22.06
	1	2	21.95	21.87	22.07
	1	5	21.86	22.05	21.62
	3	0	21.79	21.76	21.57
	3	1	21.91	21.72	21.66
	3	3	22.03	21.75	21.74
	6	0	20.73	20.6	20.77
256QAM	1	0	18.78	18.66	18.87
	1	2	19.25	18.73	18.75
	1	5	18.63	18.43	19.06
	3	0	18.66	18.72	18.57
	3	1	18.72	18.76	18.6
	3	3	18.71	18.7	18.57
	6	0	18.58	18.49	18.56





Maximum Output Power			
Modulation	Cond. Power (dBm)	EIRP (dBm)	EIRP Limit (dBm)
QPSK	23.81	24.81	30
16QAM	23.26	24.26	30
64QAM	22.07	23.07	30
256QAM	19.25	20.25	30

Note: EIRP (dBm) = Cond. Power (dBm) + Antenna Gain (dBi) + Array Gain (if applicable)

**LTE Band 66, Channel Bandwidth: 3 MHz**

Modulation	RB Size	RB Offset	Measurement Conducted Power (dBm)		
			CH 131987	CH 132322	CH 132657
			1711.5 MHz	1745 MHz	1778.5 MHz
QPSK	1	0	23.5	23.64	23.54
	1	7	23.75	23.63	23.71
	1	14	23.64	23.68	23.69
	8	0	22.78	22.69	22.66
	8	3	22.77	22.68	22.73
	8	7	22.78	22.63	22.66
	15	0	22.72	22.69	22.74
16QAM	1	0	22.85	22.96	22.54
	1	7	22.76	22.46	22.66
	1	14	22.9	22.62	22.92
	8	0	21.89	21.81	21.74
	8	3	21.73	21.6	21.73
	8	7	21.77	21.73	21.88
	15	0	21.73	21.57	21.69
64QAM	1	0	21.79	21.65	21.6
	1	7	21.83	21.71	22.08
	1	14	21.87	21.84	21.67
	8	0	20.79	20.45	20.66
	8	3	20.71	20.68	20.66
	8	7	20.68	20.81	20.63
	15	0	20.89	20.63	20.83
256QAM	1	0	18.56	18.99	18.49
	1	7	18.83	18.93	18.89
	1	14	18.66	18.88	18.5
	8	0	18.87	18.6	18.59
	8	3	18.72	18.57	18.64
	8	7	18.68	18.57	18.82
	15	0	18.73	18.61	18.73



Maximum Output Power			
Modulation	Cond. Power (dBm)	EIRP (dBm)	EIRP Limit (dBm)
QPSK	23.75	24.75	30
16QAM	22.96	23.96	30
64QAM	22.08	23.08	30
256QAM	18.99	19.99	30

Note: EIRP (dBm) = Cond. Power (dBm) + Antenna Gain (dBi) + Array Gain (if applicable)

**LTE Band 66, Channel Bandwidth: 5 MHz**

Modulation	RB Size	RB Offset	Measurement Conducted Power (dBm)		
			CH 131997	CH 132322	CH 132647
			1712.5 MHz	1745 MHz	1777.5 MHz
QPSK	1	0	23.66	23.7	23.7
	1	12	23.85	23.56	23.71
	1	24	23.8	23.81	23.81
	12	0	22.79	22.79	22.73
	12	6	22.78	22.7	22.77
	12	13	22.79	22.56	22.85
	25	0	22.79	22.76	22.75
16QAM	1	0	23.25	22.9	23.02
	1	12	23.11	22.92	22.77
	1	24	22.64	22.91	22.91
	12	0	21.76	21.79	21.75
	12	6	21.77	21.74	21.72
	12	13	21.91	21.63	21.69
	25	0	21.75	22.65	21.77
64QAM	1	0	21.88	21.72	21.96
	1	12	22.02	21.72	21.98
	1	24	21.87	21.88	21.67
	12	0	20.69	20.84	20.74
	12	6	20.87	20.8	20.75
	12	13	20.87	20.58	20.72
	25	0	20.88	20.66	20.71
256QAM	1	0	18.98	18.74	19.1
	1	12	18.82	18.85	19.23
	1	24	18.94	18.77	18.69
	12	0	18.64	18.67	18.65
	12	6	18.75	18.51	18.75
	12	13	18.77	18.64	18.78
	25	0	18.76	18.68	18.68



Maximum Output Power			
Modulation	Cond. Power (dBm)	EIRP (dBm)	EIRP Limit (dBm)
QPSK	23.85	24.85	30
16QAM	23.25	24.25	30
64QAM	22.02	23.02	30
256QAM	19.23	20.23	30

Note: EIRP (dBm) = Cond. Power (dBm) + Antenna Gain (dBi) + Array Gain (if applicable)

**LTE Band 66, Channel Bandwidth: 10 MHz**

Modulation	RB Size	RB Offset	Measurement Conducted Power (dBm)		
			CH 132022	CH 132322	CH 132622
			1715 MHz	1745 MHz	1775 MHz
QPSK	1	0	23.65	23.56	23.68
	1	24	23.81	23.63	23.73
	1	49	23.74	23.63	23.67
	25	0	22.7	22.76	22.79
	25	12	22.79	22.73	22.72
	25	25	22.88	22.65	22.88
	50	0	22.84	22.79	22.81
16QAM	1	0	22.47	22.62	23.12
	1	24	22.97	22.98	22.51
	1	49	23.3	23.01	23.06
	25	0	21.72	21.73	21.78
	25	12	21.78	21.73	21.72
	25	25	21.84	21.7	21.79
	50	0	21.75	21.79	21.81
64QAM	1	0	21.66	21.96	21.82
	1	24	22.02	21.82	21.91
	1	49	21.97	21.79	21.86
	25	0	20.77	20.75	20.81
	25	12	20.7	20.65	20.72
	25	25	20.83	20.71	20.95
	50	0	20.75	20.64	20.88
256QAM	1	0	18.87	19.02	18.54
	1	24	18.42	19.09	19.09
	1	49	19.18	18.48	18.6
	25	0	18.71	18.68	18.61
	25	12	18.78	18.63	18.67
	25	25	18.66	18.65	18.78
	50	0	18.78	18.65	18.88



Maximum Output Power			
Modulation	Cond. Power (dBm)	EIRP (dBm)	EIRP Limit (dBm)
QPSK	23.81	24.81	30
16QAM	23.3	24.3	30
64QAM	22.02	23.02	30
256QAM	19.18	20.18	30

Note: EIRP (dBm) = Cond. Power (dBm) + Antenna Gain (dBi) + Array Gain (if applicable)

**LTE Band 66, Channel Bandwidth: 15 MHz**

Modulation	RB Size	RB Offset	Measurement Conducted Power (dBm)		
			CH 132047	CH 132322	CH 132597
			1717.5 MHz	1745 MHz	1772.5 MHz
QPSK	1	0	23.68	23.7	23.63
	1	37	23.85	23.62	23.72
	1	74	23.7	23.68	23.73
	36	0	22.71	22.82	22.8
	36	19	22.75	22.7	22.67
	36	39	22.82	22.72	22.87
	75	0	22.81	22.72	22.82
16QAM	1	0	22.89	22.78	23.43
	1	37	22.95	22.74	22.94
	1	74	22.65	23.11	23.03
	36	0	21.75	21.74	21.79
	36	19	21.73	21.7	21.82
	36	39	21.9	21.71	21.89
	75	0	21.83	21.81	21.88
64QAM	1	0	21.92	21.69	21.68
	1	37	21.72	21.79	21.79
	1	74	21.97	21.97	21.94
	36	0	20.72	20.67	20.85
	36	19	20.8	20.81	20.7
	36	39	20.9	20.76	20.86
	75	0	20.77	20.73	20.72
256QAM	1	0	18.99	18.67	18.59
	1	37	18.2	18.49	18.65
	1	74	18.57	18.65	18.66
	36	0	18.74	18.66	18.78
	36	19	18.69	18.64	18.69
	36	39	18.75	18.73	18.79
	75	0	18.73	18.68	18.79





Maximum Output Power			
Modulation	Cond. Power (dBm)	EIRP (dBm)	EIRP Limit (dBm)
QPSK	23.85	24.85	30
16QAM	23.43	24.43	30
64QAM	21.97	22.97	30
256QAM	18.99	19.99	30

Note: EIRP (dBm) = Cond. Power (dBm) + Antenna Gain (dBi) + Array Gain (if applicable)

**LTE Band 66, Channel Bandwidth: 20 MHz**

Modulation	RB Size	RB Offset	Measurement Conducted Power (dBm)		
			CH 132072	CH 132322	CH 132572
			1720 MHz	1745 MHz	1770 MHz
QPSK	1	0	23.52	23.89	23.57
	1	50	23.67	23.73	23.65
	1	99	23.8	23.71	23.73
	50	0	22.85	22.85	22.94
	50	25	22.77	22.81	22.82
	50	50	22.98	22.79	22.77
	100	0	22.82	22.82	22.85
16QAM	1	0	22.73	23.38	23.03
	1	50	22.98	22.72	22.84
	1	99	22.9	23.42	22.85
	50	0	21.68	21.92	21.76
	50	25	21.84	21.75	21.81
	50	50	21.9	21.8	21.69
	100	0	21.87	21.75	21.85
64QAM	1	0	21.91	21.6	21.72
	1	50	21.87	21.9	21.63
	1	99	21.79	22.08	21.73
	50	0	20.74	20.86	20.87
	50	25	20.73	20.75	20.91
	50	50	20.86	20.75	20.81
	100	0	20.87	20.85	20.85
256QAM	1	0	19.12	18.45	18.4
	1	50	18.68	18.56	19.21
	1	99	18.8	18.7	18.52
	50	0	18.66	18.72	18.89
	50	25	18.66	18.75	18.7
	50	50	18.92	18.71	18.71
	100	0	18.77	18.79	18.71



Maximum Output Power			
Modulation	Cond. Power (dBm)	EIRP (dBm)	EIRP Limit (dBm)
QPSK	23.89	24.89	30
16QAM	23.42	24.42	30
64QAM	22.08	23.08	30
256QAM	19.21	20.21	30

Note: EIRP (dBm) = Cond. Power (dBm) + Antenna Gain (dBi) + Array Gain (if applicable)

## Mode B

### 7.1.8 LTE Band 2

#### LTE Band 2, Channel Bandwidth: 1.4 MHz

Modulation	RB Size	RB Offset	Measurement Conducted Power (dBm)		
			CH 18607	CH 18900	CH 19193
			1850.7 MHz	1880 MHz	1909.3 MHz
QPSK	1	0	22.43	22.31	22.44
	1	2	22.3	22.39	22.39
	1	5	22.33	22.52	22.33
	3	0	22.33	22.34	22.32
	3	1	22.32	22.44	22.23
	3	3	22.42	22.32	22.41
	6	0	21.33	21.34	21.38
16QAM	1	0	21.7	21.5	21.16
	1	2	21.68	21.3	21.37
	1	5	21.77	21.38	21.36
	3	0	21.28	21.28	21.43
	3	1	21.34	21.45	21.47
	3	3	21.32	21.18	21.23
	6	0	20.13	20.55	20.49
64QAM	1	0	20.45	20.54	20.59
	1	2	20.35	20.54	20.62
	1	5	20.58	20.79	20.26
	3	0	20.37	20.48	20.55
	3	1	20.45	20.68	20.33
	3	3	20.34	20.13	20.62
	6	0	19.35	19.29	19.33
256QAM	1	0	17.28	17.21	17.57
	1	2	17.34	17.15	17.35
	1	5	17.3	17.7	17.28
	3	0	17.32	17.42	17.32
	3	1	17.2	17.51	17.26
	3	3	17.41	17.27	17.33
	6	0	17.24	17.41	17.28



Maximum Output Power			
Modulation	Cond. Power (dBm)	EIRP (dBm)	EIRP Limit (dBm)
QPSK	22.55	26.05	30
16QAM	21.78	25.28	30
64QAM	20.74	24.24	30
256QAM	17.63	21.13	30

Note: EIRP (dBm) = Cond. Power (dBm) + Antenna Gain (dBi) + Array Gain (if applicable)

### LTE Band 2, Channel Bandwidth: 3 MHz

Modulation	RB Size	RB Offset	Measurement Conducted Power (dBm)		
			CH 18615	CH 18900	CH 19185
			1851.5 MHz	1880 MHz	1908.5 MHz
QPSK	1	0	22.21	22.41	22.35
	1	7	22.31	22.5	22.49
	1	14	22.32	22.35	22.29
	8	0	21.33	21.44	21.42
	8	3	21.31	21.42	21.35
	8	7	21.28	21.4	21.37
	15	0	21.33	21.27	21.34
16QAM	1	0	21.73	21.85	21.77
	1	7	21.46	21.4	22.02
	1	14	21.21	21.69	21.73
	8	0	20.33	20.43	20.45
	8	3	20.26	20.39	20.47
	8	7	20.3	20.52	20.24
	15	0	20.21	20.42	20.38
64QAM	1	0	20.33	20.62	20.68
	1	7	20.29	20.34	20.39
	1	14	20.29	20.52	20.5
	8	0	19.27	19.48	19.58
	8	3	19.19	19.43	19.5
	8	7	19.21	19.31	19.39
	15	0	19.36	19.36	19.54
256QAM	1	0	17.47	17.19	17.63
	1	7	17.2	17.71	17.9
	1	14	17.24	17.53	17.12
	8	0	17.14	17.39	17.38
	8	3	17.32	17.2	17.35
	8	7	17.22	17.23	17.3
	15	0	17.29	17.3	17.3



Maximum Output Power			
Modulation	Cond. Power (dBm)	EIRP (dBm)	EIRP Limit (dBm)
QPSK	22.5	26	30
16QAM	22.02	25.52	30
64QAM	20.68	24.18	30
256QAM	17.9	21.4	30

Note: EIRP (dBm) = Cond. Power (dBm) + Antenna Gain (dBi) + Array Gain (if applicable)

### LTE Band 2, Channel Bandwidth: 5 MHz

Modulation	RB Size	RB Offset	Measurement Conducted Power (dBm)		
			CH 18625	CH 18900	CH 19175
			1852.5 MHz	1880 MHz	1907.5 MHz
QPSK	1	0	22.42	22.47	22.54
	1	12	22.41	22.46	22.49
	1	24	22.43	22.45	22.33
	12	0	21.34	21.34	21.43
	12	6	21.36	21.46	21.37
	12	13	21.26	21.45	21.4
	25	0	21.41	21.36	21.36
16QAM	1	0	21.77	21.58	21.49
	1	12	21.47	21.53	21.6
	1	24	22.06	21.44	21.7
	12	0	20.51	20.53	20.56
	12	6	20.26	20.36	20.44
	12	13	20.38	20.26	20.26
	25	0	20.29	21.31	20.49
64QAM	1	0	20.28	20.69	20.58
	1	12	20.63	20.47	20.23
	1	24	20.29	20.61	20.64
	12	0	19.18	19.38	19.5
	12	6	19.41	19.52	19.54
	12	13	19.27	19.29	19.27
	25	0	19.37	19.4	19.49
256QAM	1	0	17.17	17.7	17.31
	1	12	17.13	17.49	17.52
	1	24	17.36	17.21	17.37
	12	0	17.22	17.32	17.48
	12	6	17.24	17.42	17.74
	12	13	17.19	17.2	17.26
	25	0	17.28	17.31	17.45





Maximum Output Power			
Modulation	Cond. Power (dBm)	EIRP (dBm)	EIRP Limit (dBm)
QPSK	22.54	26.04	30
16QAM	22.06	25.56	30
64QAM	20.69	24.19	30
256QAM	17.74	21.24	30

Note: EIRP (dBm) = Cond. Power (dBm) + Antenna Gain (dBi) + Array Gain (if applicable)

**LTE Band 2, Channel Bandwidth: 10 MHz**

Modulation	RB Size	RB Offset	Measurement Conducted Power (dBm)		
			CH 18650	CH 18900	CH 19150
			1855 MHz	1880 MHz	1905 MHz
QPSK	1	0	22.3	22.48	22.48
	1	24	22.22	22.31	22.57
	1	49	22.28	22.6	22.34
	25	0	21.36	21.45	21.59
	25	12	21.34	21.43	21.5
	25	25	21.27	21.28	21.4
	50	0	21.43	21.46	21.48
16QAM	1	0	21.21	21.83	21.28
	1	24	21.45	22.25	21.57
	1	49	21.58	21.58	21.83
	25	0	20.34	20.29	20.55
	25	12	20.27	20.41	20.33
	25	25	20.25	20.28	20.34
	50	0	20.28	20.49	20.36
64QAM	1	0	20.3	20.63	20.34
	1	24	20.4	20.64	20.31
	1	49	20.63	20.62	20.32
	25	0	19.41	19.31	19.56
	25	12	19.35	19.46	19.39
	25	25	19.38	19.37	19.4
	50	0	19.48	19.44	19.4
256QAM	1	0	17.6	17.32	17.59
	1	24	17.31	17.47	17.75
	1	49	17.67	17.49	17.19
	25	0	17.4	17.5	17.41
	25	12	17.26	17.34	17.27
	25	25	17.22	17.21	17.31
	50	0	17.33	17.28	17.36



Maximum Output Power			
Modulation	Cond. Power (dBm)	EIRP (dBm)	EIRP Limit (dBm)
QPSK	22.6	26.1	30
16QAM	22.25	25.75	30
64QAM	20.64	24.14	30
256QAM	17.75	21.25	30

Note: EIRP (dBm) = Cond. Power (dBm) + Antenna Gain (dBi) + Array Gain (if applicable)

**LTE Band 2, Channel Bandwidth: 15 MHz**

Modulation	RB Size	RB Offset	Measurement Conducted Power (dBm)		
			CH 18675	CH 18900	CH 19125
			1857.5 MHz	1880 MHz	1902.5 MHz
QPSK	1	0	22.14	22.26	22.53
	1	37	22.44	22.31	22.5
	1	74	22.37	22.4	22.33
	36	0	21.34	21.39	21.37
	36	19	21.34	21.42	21.42
	36	39	21.41	21.38	21.33
	75	0	21.39	21.38	21.27
16QAM	1	0	22.07	21.6	21.44
	1	37	22.29	22.32	21.53
	1	74	21.66	22.16	21.69
	36	0	20.27	20.41	20.25
	36	19	20.35	20.45	20.5
	36	39	20.23	20.39	20.34
	75	0	20.42	20.51	20.32
64QAM	1	0	20.48	20.51	20.43
	1	37	20.87	20.15	20.54
	1	74	20.49	20.59	20.63
	36	0	19.43	19.49	19.26
	36	19	19.35	19.34	19.36
	36	39	19.36	19.34	19.28
	75	0	19.28	19.29	19.33
256QAM	1	0	17.45	17.44	17.29
	1	37	17.7	17.83	17.29
	1	74	17.62	17.72	17.71
	36	0	17.28	17.24	17.22
	36	19	17.17	17.36	17.35
	36	39	17.26	17.3	17.2
	75	0	17.33	17.43	17.23



Maximum Output Power			
Modulation	Cond. Power (dBm)	EIRP (dBm)	EIRP Limit (dBm)
QPSK	22.53	26.03	30
16QAM	22.32	25.82	30
64QAM	20.87	24.37	30
256QAM	17.83	21.33	30

Note: EIRP (dBm) = Cond. Power (dBm) + Antenna Gain (dBi) + Array Gain (if applicable)

**LTE Band 2, Channel Bandwidth: 20 MHz**

Modulation	RB Size	RB Offset	Measurement Conducted Power (dBm)		
			CH 18700	CH 18900	CH 19100
			1860 MHz	1880 MHz	1900 MHz
QPSK	1	0	22.23	22.57	22.36
	1	50	22.29	22.54	22.48
	1	99	22.28	22.56	22.52
	50	0	21.51	21.51	21.28
	50	25	21.38	21.38	21.43
	50	50	21.4	21.34	21.33
	100	0	21.53	21.32	21.3
16QAM	1	0	21.71	21.26	21.53
	1	50	21.93	21.65	21.72
	1	99	21.46	22.08	21.68
	50	0	20.53	20.42	20.27
	50	25	20.45	20.38	20.54
	50	50	20.52	20.33	20.04
	100	0	20.55	20.33	20.26
64QAM	1	0	20.55	20.39	20.81
	1	50	20.08	20.81	20.91
	1	99	20.35	20.64	20.65
	50	0	19.49	19.34	19.27
	50	25	19.39	19.45	19.42
	50	50	19.37	19.16	19.16
	100	0	19.44	19.16	19.21
256QAM	1	0	17	17.09	17.14
	1	50	17.65	17.29	17.67
	1	99	17.22	17.37	17.67
	50	0	17.34	17.3	17.29
	50	25	17.26	17.32	17.39
	50	50	17.39	17.23	17.02
	100	0	17.34	17.12	17.13



Maximum Output Power			
Modulation	Cond. Power (dBm)	EIRP (dBm)	EIRP Limit (dBm)
QPSK	22.57	26.07	30
16QAM	22.08	25.58	30
64QAM	20.91	24.41	30
256QAM	17.67	21.17	30

Note: EIRP (dBm) = Cond. Power (dBm) + Antenna Gain (dBi) + Array Gain (if applicable)

### 7.1.9 LTE Band 4

#### LTE Band 4, Channel Bandwidth: 1.4 MHz

Modulation	RB Size	RB Offset	Measurement Conducted Power (dBm)		
			CH 19957	CH 20175	CH 20393
			1710.7 MHz	1732.5 MHz	1754.3 MHz
QPSK	1	0	22.36	22.38	22.36
	1	2	22.42	22.54	22.51
	1	5	22.34	22.29	22.34
	3	0	22.56	22.37	22.37
	3	1	22.5	22.5	22.44
	3	3	22.38	22.25	22.46
	6	0	21.3	21.29	21.32
16QAM	1	0	21.42	21.52	21.33
	1	2	21.32	21.64	21.46
	1	5	21.29	22.17	21.49
	3	0	21.42	21.46	21.28
	3	1	21.57	21.34	21.24
	3	3	21.33	21.48	21.43
	6	0	20.46	20.16	20.36
64QAM	1	0	20.74	20.43	20.63
	1	2	20.43	20.31	20.77
	1	5	20.05	20.25	20.42
	3	0	20.31	20.63	20.37
	3	1	20.36	20.47	20.64
	3	3	20.62	20.15	20.49
	6	0	19.55	19.53	19.27
256QAM	1	0	17.22	17.58	17.23
	1	2	16.98	17.27	17.39
	1	5	17.68	17.55	17.26
	3	0	17.23	17.19	17.46
	3	1	17.66	17.51	17.23
	3	3	17.41	17.29	17.37
	6	0	17.42	17.21	17.39





Maximum Output Power			
Modulation	Cond. Power (dBm)	EIRP (dBm)	EIRP Limit (dBm)
QPSK	22.56	26.06	30
16QAM	22.17	25.67	30
64QAM	20.77	24.27	30
256QAM	17.68	21.18	30

Note: EIRP (dBm) = Cond. Power (dBm) + Antenna Gain (dBi) + Array Gain (if applicable)

### LTE Band 4, Channel Bandwidth: 3 MHz

Modulation	RB Size	RB Offset	Measurement Conducted Power (dBm)		
			CH 19965	CH 20175	CH 20385
			1711.5 MHz	1732.5 MHz	1753.5 MHz
QPSK	1	0	22.23	22.29	22.43
	1	7	22.43	22.45	22.45
	1	14	22.2	22.33	22.31
	8	0	21.56	21.36	21.44
	8	3	21.38	21.39	21.5
	8	7	21.47	21.48	21.46
	15	0	21.46	21.39	21.31
16QAM	1	0	21.42	21.49	21.52
	1	7	21.67	21.58	21.41
	1	14	21.82	21.34	21.71
	8	0	20.53	20.56	20.68
	8	3	20.37	20.41	20.36
	8	7	20.61	20.56	20.52
	15	0	20.34	20.38	20.42
64QAM	1	0	20.45	20.4	20.74
	1	7	20.34	20.61	20.71
	1	14	20.69	20.37	20.56
	8	0	19.32	19.52	19.31
	8	3	19.45	19.33	19.33
	8	7	19.67	19.28	19.28
	15	0	19.36	19.36	19.35
256QAM	1	0	17.72	17.81	17.62
	1	7	17.88	17.88	17.65
	1	14	17.77	17.67	17.64
	8	0	17.32	17.43	17.33
	8	3	17.27	17.44	17.44
	8	7	17.29	17.33	17.23
	15	0	17.39	17.44	17.36



Maximum Output Power			
Modulation	Cond. Power (dBm)	EIRP (dBm)	EIRP Limit (dBm)
QPSK	22.45	25.95	30
16QAM	21.82	25.32	30
64QAM	20.74	24.24	30
256QAM	17.88	21.38	30

Note: EIRP (dBm) = Cond. Power (dBm) + Antenna Gain (dBi) + Array Gain (if applicable)

**LTE Band 4, Channel Bandwidth: 5 MHz**

Modulation	RB Size	RB Offset	Measurement Conducted Power (dBm)		
			CH 19975	CH 20175	CH 20375
			1712.5 MHz	1732.5 MHz	1752.5 MHz
QPSK	1	0	22.38	22.47	22.35
	1	12	22.34	22.55	22.34
	1	24	22.54	22.36	22.33
	12	0	21.41	21.3	21.34
	12	6	21.3	21.46	21.44
	12	13	21.31	21.42	21.48
	25	0	21.42	21.35	21.47
16QAM	1	0	21.34	21.89	21.66
	1	12	22.14	21.31	21.34
	1	24	21.22	21.78	21.55
	12	0	20.38	20.3	20.27
	12	6	20.49	20.5	20.22
	12	13	20.45	20.25	20.32
	25	0	20.4	21.32	20.41
64QAM	1	0	20.31	20.33	20.51
	1	12	20.6	20.92	20.54
	1	24	20.35	20.64	20.28
	12	0	19.42	19.45	19.48
	12	6	19.3	19.43	19.53
	12	13	19.57	19.32	19.51
	25	0	19.38	19.36	19.3
256QAM	1	0	17.26	17.05	17.35
	1	12	17.92	17.14	17.53
	1	24	17.22	17.44	17.6
	12	0	17.34	17.25	17.41
	12	6	17.28	17.31	17.24
	12	13	17.18	17.33	17.28
	25	0	17.44	17.4	17.35



Maximum Output Power			
Modulation	Cond. Power (dBm)	EIRP (dBm)	EIRP Limit (dBm)
QPSK	22.55	26.05	30
16QAM	22.14	25.64	30
64QAM	20.92	24.42	30
256QAM	17.92	21.42	30

Note: EIRP (dBm) = Cond. Power (dBm) + Antenna Gain (dBi) + Array Gain (if applicable)

**LTE Band 4, Channel Bandwidth: 10 MHz**

Modulation	RB Size	RB Offset	Measurement Conducted Power (dBm)		
			CH 20000	CH 20175	CH 20350
			1715 MHz	1732.5 MHz	1750 MHz
QPSK	1	0	22.25	22.27	22.41
	1	24	22.19	22.21	22.41
	1	49	22.34	22.51	22.34
	25	0	21.35	21.38	21.44
	25	12	21.37	21.39	21.44
	25	25	21.45	21.33	21.48
	50	0	21.49	21.3	21.57
16QAM	1	0	21.72	21.73	21.63
	1	24	21.98	21.93	21.21
	1	49	21.6	21.72	21.7
	25	0	20.27	20.31	20.36
	25	12	20.46	20.42	20.46
	25	25	20.33	20.26	20.38
	50	0	20.53	20.32	20.43
64QAM	1	0	20.42	20.31	20.11
	1	24	20.41	20.86	20.26
	1	49	20.49	20.65	20.29
	25	0	19.37	19.38	19.47
	25	12	19.38	19.4	19.38
	25	25	19.35	19.42	19.39
	50	0	19.48	19.39	19.43
256QAM	1	0	17.45	17.37	17.84
	1	24	17.43	17.3	17.7
	1	49	17.14	18.09	17.42
	25	0	17.34	17.26	17.41
	25	12	17.28	17.23	17.37
	25	25	17.47	17.41	17.46
	50	0	17.38	17.17	17.34



Maximum Output Power			
Modulation	Cond. Power (dBm)	EIRP (dBm)	EIRP Limit (dBm)
QPSK	22.51	26.01	30
16QAM	21.98	25.48	30
64QAM	20.86	24.36	30
256QAM	18.09	21.59	30

Note: EIRP (dBm) = Cond. Power (dBm) + Antenna Gain (dBi) + Array Gain (if applicable)

### LTE Band 4, Channel Bandwidth: 15 MHz

Modulation	RB Size	RB Offset	Measurement Conducted Power (dBm)		
			CH 20025	CH 20175	CH 20325
			1717.5 MHz	1732.5 MHz	1747.5 MHz
QPSK	1	0	22.23	22.55	22.43
	1	37	22.45	22.3	22.4
	1	74	22.45	22.45	22.39
	36	0	21.31	21.45	21.57
	36	19	21.43	21.49	21.46
	36	39	21.52	21.48	21.52
	75	0	21.35	21.36	21.56
16QAM	1	0	21.35	21.59	21.47
	1	37	21.76	21.94	21.63
	1	74	21.2	21.59	21.75
	36	0	20.42	20.34	20.43
	36	19	20.26	20.35	20.38
	36	39	20.5	20.29	20.62
	75	0	20.53	20.45	20.48
64QAM	1	0	20.26	20.62	20.38
	1	37	20.35	20.45	20.63
	1	74	20.78	20.49	20.58
	36	0	19.46	19.27	19.47
	36	19	19.27	19.39	19.41
	36	39	19.58	19.43	19.59
	75	0	19.31	19.38	19.32
256QAM	1	0	17.12	17.16	17.26
	1	37	17.85	17.4	17.52
	1	74	17.71	17.22	17.74
	36	0	17.28	17.23	17.5
	36	19	17.3	17.33	17.45
	36	39	17.33	17.47	17.4
	75	0	17.33	17.49	17.36





Maximum Output Power			
Modulation	Cond. Power (dBm)	EIRP (dBm)	EIRP Limit (dBm)
QPSK	22.55	26.05	30
16QAM	21.94	25.44	30
64QAM	20.78	24.28	30
256QAM	17.85	21.35	30

Note: EIRP (dBm) = Cond. Power (dBm) + Antenna Gain (dBi) + Array Gain (if applicable)

**LTE Band 4, Channel Bandwidth: 20 MHz**

Modulation	RB Size	RB Offset	Measurement Conducted Power (dBm)		
			CH 20050	CH 20175	CH 20300
			1720 MHz	1732.5 MHz	1745 MHz
QPSK	1	0	22.42	22.73	22.45
	1	50	22.36	22.52	22.4
	1	99	22.58	22.44	22.41
	50	0	21.32	21.39	21.52
	50	25	21.37	21.43	21.44
	50	50	21.67	21.41	21.47
	100	0	21.53	21.26	21.39
16QAM	1	0	21.9	21.47	21.44
	1	50	21.72	21.43	21.62
	1	99	22.16	21.63	21.55
	50	0	20.37	20.44	20.48
	50	25	20.46	20.55	20.33
	50	50	20.52	20.32	20.45
	100	0	20.48	20.4	20.44
64QAM	1	0	20.09	20.79	20.67
	1	50	20.48	20.51	20.69
	1	99	20.4	20.63	20.68
	50	0	19.22	19.24	19.39
	50	25	19.46	19.44	19.36
	50	50	19.6	19.33	19.47
	100	0	19.35	19.32	19.52
256QAM	1	0	17.81	17.8	17.2
	1	50	17.43	17.33	17.01
	1	99	17.51	17.81	17.57
	50	0	17.3	17.28	17.32
	50	25	17.46	17.27	17.41
	50	50	17.45	17.24	17.49
	100	0	17.4	17.12	17.39



Maximum Output Power			
Modulation	Cond. Power (dBm)	EIRP (dBm)	EIRP Limit (dBm)
QPSK	22.73	26.23	30
16QAM	22.16	25.66	30
64QAM	20.79	24.29	30
256QAM	17.81	21.31	30

Note: EIRP (dBm) = Cond. Power (dBm) + Antenna Gain (dBi) + Array Gain (if applicable)

## 7.1.10LTE Band 30

**LTE Band 30, Channel Bandwidth: 5 MHz**

Modulation	RB Size	RB Offset	Measurement Conducted Power (dBm)		
			CH 27685	CH 27710	CH 27735
			2307.5 MHz	2310 MHz	2312.5 MHz
QPSK	1	0	22.4	22.29	22.27
	1	12	22.29	22.32	22.37
	1	24	22.41	22.27	22.37
	12	0	21.37	21.38	21.18
	12	6	21.33	21.41	21.15
	12	13	21.15	21.21	21.18
	25	0	21.34	21.34	21.32
16QAM	1	0	21.4	21.86	21.13
	1	12	21.54	21.59	21.31
	1	24	21.33	21.56	21.3
	12	0	20.36	20.34	20.16
	12	6	20.28	20.41	20.19
	12	13	20.32	20.26	20.22
	25	0	20.28	21.31	20.34
64QAM	1	0	20.46	20.1	20.51
	1	12	20.37	20.22	20.72
	1	24	20.54	20.18	20.17
	12	0	19.16	19.15	19.3
	12	6	19.33	19.13	19.18
	12	13	19.33	19.17	19.25
	25	0	19.15	19.4	19.21
256QAM	1	0	17.06	17.24	17.24
	1	12	17	17.04	17.85
	1	24	17.85	17.17	17.51
	12	0	17.05	17.22	17.09
	12	6	17.1	17.25	17.18
	12	13	17.02	17.2	16.99
	25	0	17.09	17.2	17.11



Maximum Output Power			
Modulation	Cond. Power (dBm)	EIRP (dBm)	EIRP Limit (dBm)
QPSK	22.41	26.41	30
16QAM	21.86	25.86	30
64QAM	20.72	24.72	30
256QAM	17.85	21.85	30

Note: EIRP (dBm) = Cond. Power (dBm) + Antenna Gain (dBi) + Array Gain (if applicable)

**LTE Band 30, Channel Bandwidth: 10 MHz**

Modulation	RB Size	RB Offset	Measurement Conducted Power (dBm)
			CH 27710
			2310 MHz
QPSK	1	0	22.49
	1	24	22.43
	1	49	22.28
	25	0	21.32
	25	12	21.27
	25	25	21.25
	50	0	21.39
16QAM	1	0	21.78
	1	24	21.33
	1	49	21.82
	25	0	20.2
	25	12	20.41
	25	25	20.29
	50	0	20.42
64QAM	1	0	20.57
	1	24	20.24
	1	49	20
	25	0	19.35
	25	12	19.25
	25	25	19.21
	50	0	19.28
256QAM	1	0	17.31
	1	24	17.24
	1	49	17.23
	25	0	17.22
	25	12	17.09
	25	25	17.11
	50	0	17.18



Maximum Output Power			
Modulation	Cond. Power (dBm)	EIRP (dBm)	EIRP Limit (dBm)
QPSK	22.49	26.49	30
16QAM	21.82	25.82	30
64QAM	20.57	24.57	30
256QAM	17.31	21.31	30

Note: EIRP (dBm) = Cond. Power (dBm) + Antenna Gain (dBi) + Array Gain (if applicable)

7.1.11LTE Band 66

**LTE Band 66, Channel Bandwidth: 1.4 MHz**

Modulation	RB Size	RB Offset	Measurement Conducted Power (dBm)		
			CH 131979	CH 132322	CH 132665
			1710.7 MHz	1745 MHz	1779.3 MHz
QPSK	1	0	22.34	22.44	22.28
	1	2	22.32	22.45	22.33
	1	5	22.47	22.16	22.43
	3	0	22.33	22.46	22.41
	3	1	22.49	22.35	22.36
	3	3	22.37	22.33	22.49
	6	0	21.43	21.27	21.38
16QAM	1	0	21.23	21.93	21.99
	1	2	21.79	21.85	21.44
	1	5	21.37	21.69	21.7
	3	0	21.32	21.34	21.51
	3	1	21.31	21.34	21.5
	3	3	21.44	21.21	21.42
	6	0	20.4	20.39	20.52
64QAM	1	0	20.49	20.28	20.71
	1	2	20.55	20.61	20.78
	1	5	20.5	20.67	20.36
	3	0	20.47	20.45	20.19
	3	1	20.58	20.44	20.27
	3	3	20.66	20.39	20.41
	6	0	19.38	19.34	19.44
256QAM	1	0	17.42	17.41	17.58
	1	2	17.97	17.44	17.47
	1	5	17.36	17.14	17.73
	3	0	17.26	17.44	17.22
	3	1	17.32	17.37	17.26
	3	3	17.38	17.43	17.29
	6	0	17.3	17.23	17.17





Maximum Output Power			
Modulation	Cond. Power (dBm)	EIRP (dBm)	EIRP Limit (dBm)
QPSK	22.49	25.99	30
16QAM	21.99	25.49	30
64QAM	20.78	24.28	30
256QAM	17.97	21.47	30

Note: EIRP (dBm) = Cond. Power (dBm) + Antenna Gain (dBi) + Array Gain (if applicable)

**LTE Band 66, Channel Bandwidth: 3 MHz**

Modulation	RB Size	RB Offset	Measurement Conducted Power (dBm)		
			CH 131987	CH 132322	CH 132657
			1711.5 MHz	1745 MHz	1778.5 MHz
QPSK	1	0	22.19	22.36	22.18
	1	7	22.39	22.26	22.39
	1	14	22.37	22.39	22.33
	8	0	21.51	21.4	21.4
	8	3	21.46	21.42	21.44
	8	7	21.43	21.29	21.41
	15	0	21.41	21.44	21.42
16QAM	1	0	21.46	21.71	21.17
	1	7	21.5	21.09	21.39
	1	14	21.53	21.32	21.56
	8	0	20.59	20.44	20.45
	8	3	20.34	20.29	20.38
	8	7	20.37	20.33	20.62
	15	0	20.41	20.18	20.44
64QAM	1	0	20.49	20.32	20.34
	1	7	20.49	20.37	20.83
	1	14	20.6	20.49	20.36
	8	0	19.48	19.2	19.33
	8	3	19.42	19.31	19.26
	8	7	19.3	19.43	19.36
	15	0	19.55	19.36	19.56
256QAM	1	0	17.21	17.62	17.19
	1	7	17.49	17.55	17.49
	1	14	17.32	17.5	17.25
	8	0	17.51	17.35	17.27
	8	3	17.41	17.28	17.38
	8	7	17.37	17.28	17.46
	15	0	17.43	17.21	17.46



Maximum Output Power			
Modulation	Cond. Power (dBm)	EIRP (dBm)	EIRP Limit (dBm)
QPSK	22.39	25.89	30
16QAM	21.71	25.21	30
64QAM	20.83	24.33	30
256QAM	17.62	21.12	30

Note: EIRP (dBm) = Cond. Power (dBm) + Antenna Gain (dBi) + Array Gain (if applicable)

**LTE Band 66, Channel Bandwidth: 5 MHz**

Modulation	RB Size	RB Offset	Measurement Conducted Power (dBm)		
			CH 131997	CH 132322	CH 132647
			1712.5 MHz	1745 MHz	1777.5 MHz
QPSK	1	0	22.3	22.34	22.43
	1	12	22.58	22.25	22.41
	1	24	22.49	22.54	22.55
	12	0	21.46	21.46	21.42
	12	6	21.46	21.42	21.42
	12	13	21.51	21.19	21.52
	25	0	21.51	21.45	21.4
16QAM	1	0	21.94	21.54	21.64
	1	12	21.8	21.6	21.45
	1	24	21.25	21.57	21.54
	12	0	20.47	20.53	20.37
	12	6	20.47	20.4	20.33
	12	13	20.62	20.25	20.29
	25	0	20.4	21.4	20.5
64QAM	1	0	20.53	20.39	20.65
	1	12	20.74	20.41	20.73
	1	24	20.48	20.51	20.4
	12	0	19.43	19.54	19.36
	12	6	19.47	19.55	19.36
	12	13	19.49	19.19	19.41
	25	0	19.5	19.37	19.36
256QAM	1	0	17.59	17.43	17.84
	1	12	17.42	17.47	17.92
	1	24	17.56	17.52	17.32
	12	0	17.32	17.37	17.4
	12	6	17.4	17.15	17.47
	12	13	17.43	17.37	17.52
	25	0	17.48	17.28	17.41



Maximum Output Power			
Modulation	Cond. Power (dBm)	EIRP (dBm)	EIRP Limit (dBm)
QPSK	22.58	26.08	30
16QAM	21.94	25.44	30
64QAM	20.74	24.24	30
256QAM	17.92	21.42	30

Note: EIRP (dBm) = Cond. Power (dBm) + Antenna Gain (dBi) + Array Gain (if applicable)

**LTE Band 66, Channel Bandwidth: 10 MHz**

Modulation	RB Size	RB Offset	Measurement Conducted Power (dBm)		
			CH 132022	CH 132322	CH 132622
			1715 MHz	1745 MHz	1775 MHz
QPSK	1	0	22.4	22.25	22.3
	1	24	22.44	22.37	22.34
	1	49	22.39	22.28	22.42
	25	0	21.42	21.43	21.41
	25	12	21.51	21.45	21.44
	25	25	21.63	21.25	21.63
	50	0	21.59	21.54	21.45
16QAM	1	0	21.18	21.28	21.77
	1	24	21.58	21.65	21.16
	1	49	21.93	21.62	21.73
	25	0	20.42	20.41	20.49
	25	12	20.45	20.36	20.32
	25	25	20.52	20.36	20.48
	50	0	20.49	20.53	20.55
64QAM	1	0	20.37	20.68	20.42
	1	24	20.63	20.49	20.64
	1	49	20.58	20.53	20.48
	25	0	19.42	19.37	19.45
	25	12	19.45	19.39	19.38
	25	25	19.5	19.44	19.7
	50	0	19.37	19.35	19.55
256QAM	1	0	17.49	17.68	17.21
	1	24	17.09	17.81	17.72
	1	49	17.82	17.19	17.33
	25	0	17.4	17.34	17.28
	25	12	17.52	17.35	17.34
	25	25	17.29	17.27	17.44
	50	0	17.43	17.37	17.51



Maximum Output Power			
Modulation	Cond. Power (dBm)	EIRP (dBm)	EIRP Limit (dBm)
QPSK	22.44	25.94	30
16QAM	21.93	25.43	30
64QAM	20.68	24.18	30
256QAM	17.82	21.32	30

Note: EIRP (dBm) = Cond. Power (dBm) + Antenna Gain (dBi) + Array Gain (if applicable)

**LTE Band 66, Channel Bandwidth: 15 MHz**

Modulation	RB Size	RB Offset	Measurement Conducted Power (dBm)		
			CH 132047	CH 132322	CH 132597
			1717.5 MHz	1745 MHz	1772.5 MHz
QPSK	1	0	22.43	22.44	22.33
	1	37	22.45	22.25	22.43
	1	74	22.38	22.4	22.4
	36	0	21.38	21.44	21.49
	36	19	21.37	21.42	21.32
	36	39	21.42	21.44	21.56
	75	0	21.47	21.47	21.44
16QAM	1	0	21.62	21.4	22.03
	1	37	21.58	21.38	21.64
	1	74	21.3	21.85	21.68
	36	0	20.37	20.49	20.53
	36	19	20.41	20.33	20.43
	36	39	20.59	20.38	20.62
	75	0	20.5	20.54	20.58
64QAM	1	0	20.58	20.31	20.3
	1	37	20.42	20.42	20.44
	1	74	20.66	20.61	20.66
	36	0	19.42	19.36	19.49
	36	19	19.53	19.43	19.32
	36	39	19.58	19.46	19.57
	75	0	19.42	19.45	19.41
256QAM	1	0	17.73	17.39	17.29
	1	37	16.87	17.21	17.34
	1	74	17.26	17.37	17.3
	36	0	17.34	17.29	17.43
	36	19	17.44	17.26	17.41
	36	39	17.38	17.48	17.48
	75	0	17.41	17.36	17.52





Maximum Output Power			
Modulation	Cond. Power (dBm)	EIRP (dBm)	EIRP Limit (dBm)
QPSK	22.45	25.95	30
16QAM	22.03	25.53	30
64QAM	20.66	24.16	30
256QAM	17.73	21.23	30

Note: EIRP (dBm) = Cond. Power (dBm) + Antenna Gain (dBi) + Array Gain (if applicable)

**LTE Band 66, Channel Bandwidth: 20 MHz**

Modulation	RB Size	RB Offset	Measurement Conducted Power (dBm)		
			CH 132072	CH 132322	CH 132572
			1720 MHz	1745 MHz	1770 MHz
QPSK	1	0	22.12	22.57	22.26
	1	50	22.37	22.4	22.33
	1	99	22.52	22.45	22.36
	50	0	21.52	21.47	21.63
	50	25	21.38	21.52	21.57
	50	50	21.58	21.53	21.44
	100	0	21.5	21.42	21.45
16QAM	1	0	21.35	22.11	21.7
	1	50	21.59	21.34	21.58
	1	99	21.63	22.07	21.59
	50	0	20.4	20.54	20.44
	50	25	20.45	20.43	20.44
	50	50	20.57	20.5	20.32
	100	0	20.5	20.47	20.57
64QAM	1	0	20.55	20.23	20.46
	1	50	20.62	20.59	20.38
	1	99	20.46	20.7	20.44
	50	0	19.44	19.47	19.59
	50	25	19.41	19.48	19.59
	50	50	19.53	19.44	19.5
	100	0	19.59	19.53	19.55
256QAM	1	0	17.72	17.07	17.02
	1	50	17.34	17.18	17.81
	1	99	17.4	17.35	17.26
	50	0	17.41	17.44	17.51
	50	25	17.37	17.46	17.43
	50	50	17.67	17.35	17.46
	100	0	17.44	17.43	17.4



Maximum Output Power			
Modulation	Cond. Power (dBm)	EIRP (dBm)	EIRP Limit (dBm)
QPSK	22.57	26.07	30
16QAM	22.11	25.61	30
64QAM	20.7	24.2	30
256QAM	17.81	21.31	30

Note: EIRP (dBm) = Cond. Power (dBm) + Antenna Gain (dBi) + Array Gain (if applicable)

## 7.2 Modulation Characteristics

Input Power:	120 Vac, 60 Hz	Environmental Conditions:	22°C, 74% RH	Tested By:	Willy Cheng
--------------	----------------	---------------------------	--------------	------------	-------------

### 7.2.1 LTE Band 2

#### LTE Band 2, Channel Bandwidth: 20 MHz

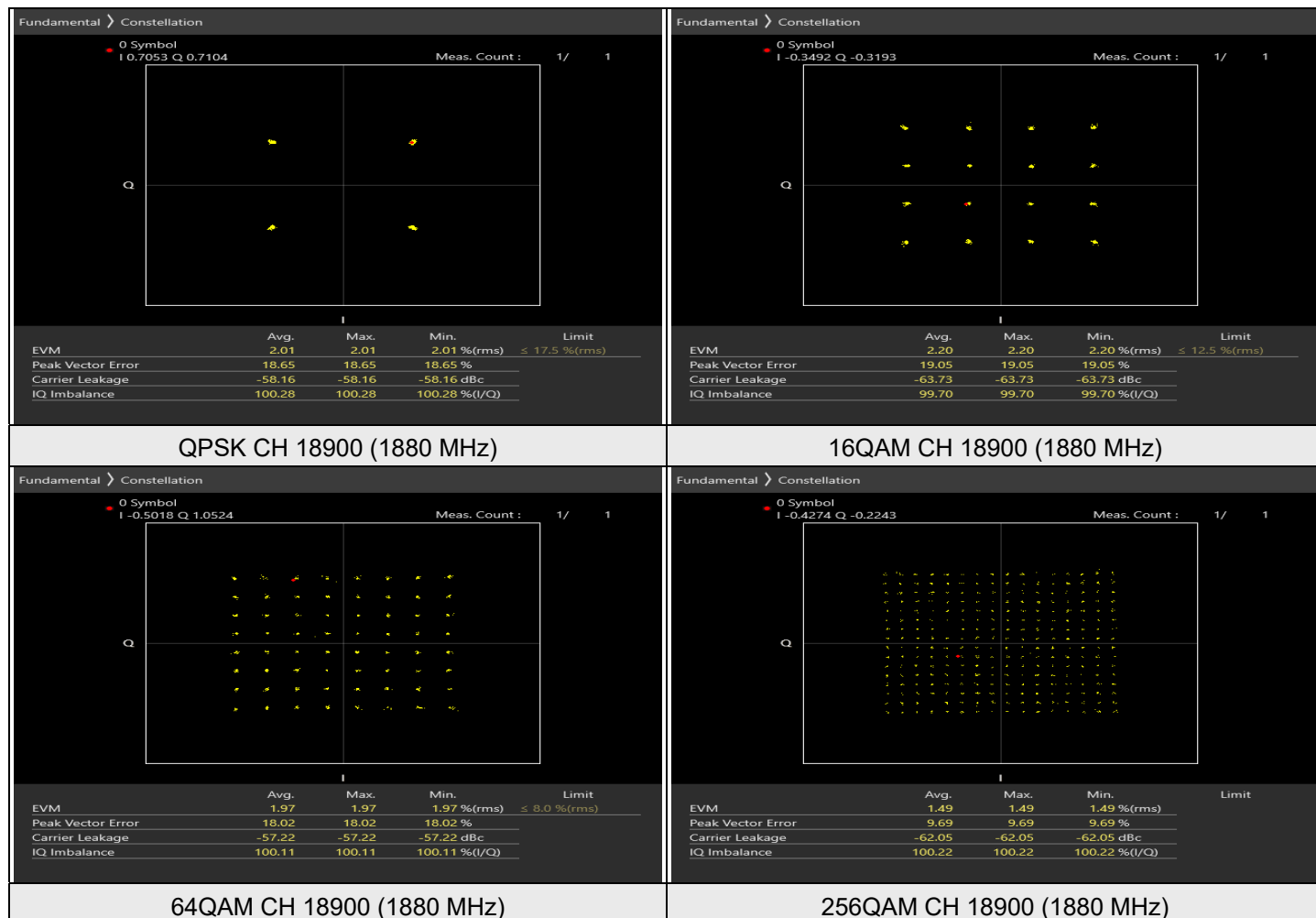

## 7.2.2 LTE Band 4

### LTE Band 4, Channel Bandwidth: 20 MHz



### 7.2.3 LTE Band 5

#### LTE Band 5, Channel Bandwidth: 10 MHz

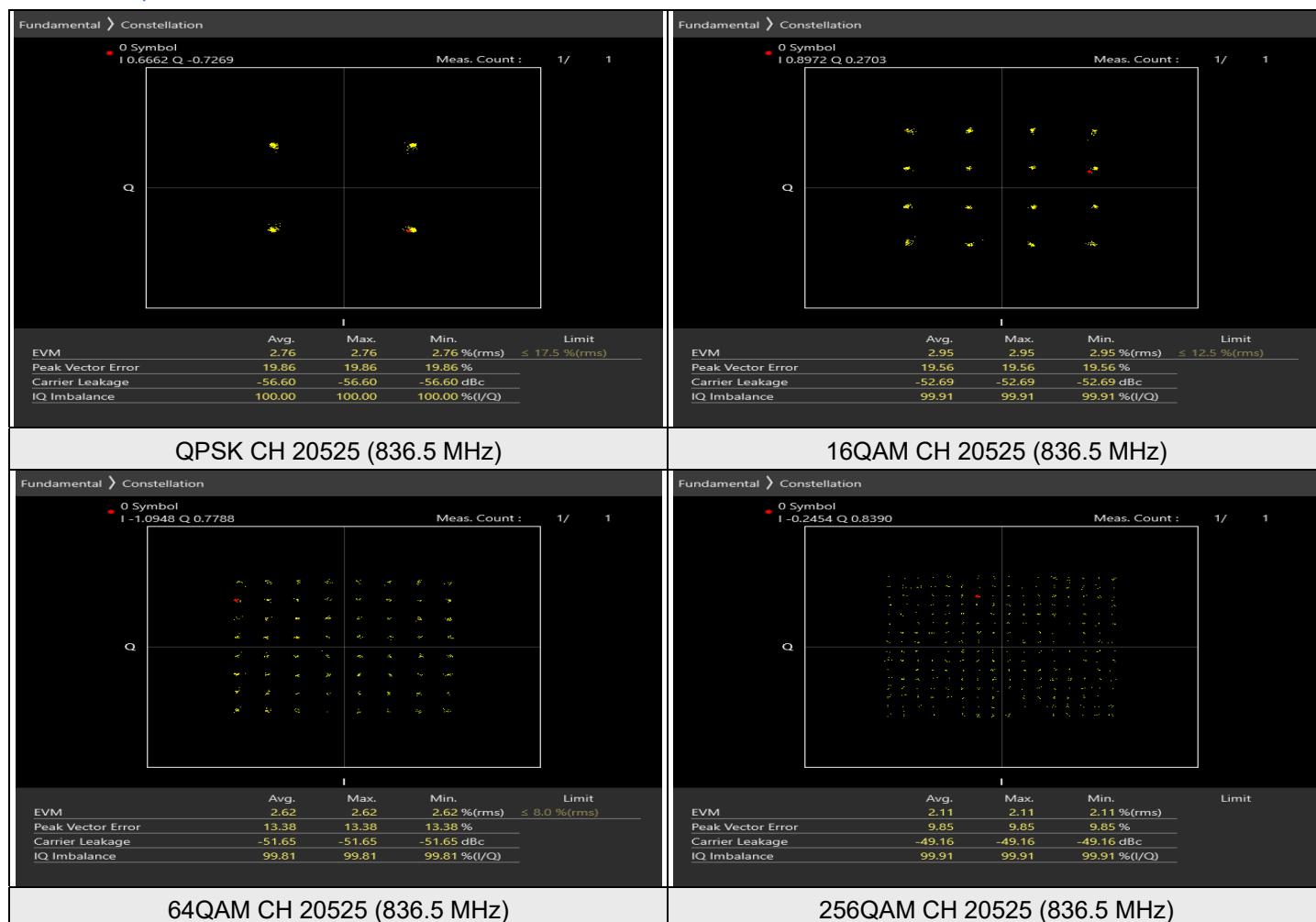

## 7.2.4 LTE Band 12

### LTE Band 12, Channel Bandwidth: 10 MHz

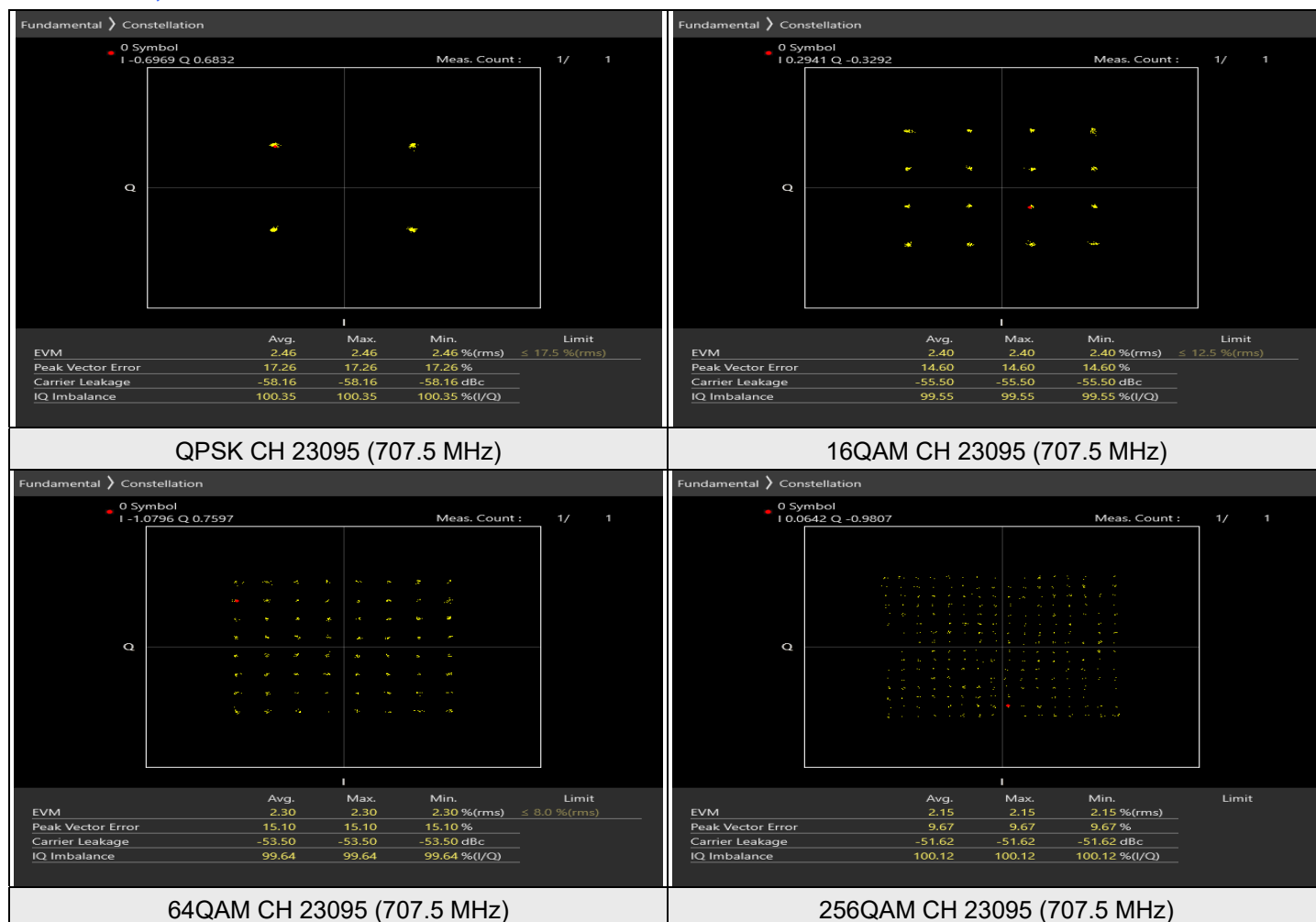

## 7.2.5 LTE Band 14

### LTE Band 14, Channel Bandwidth: 10 MHz

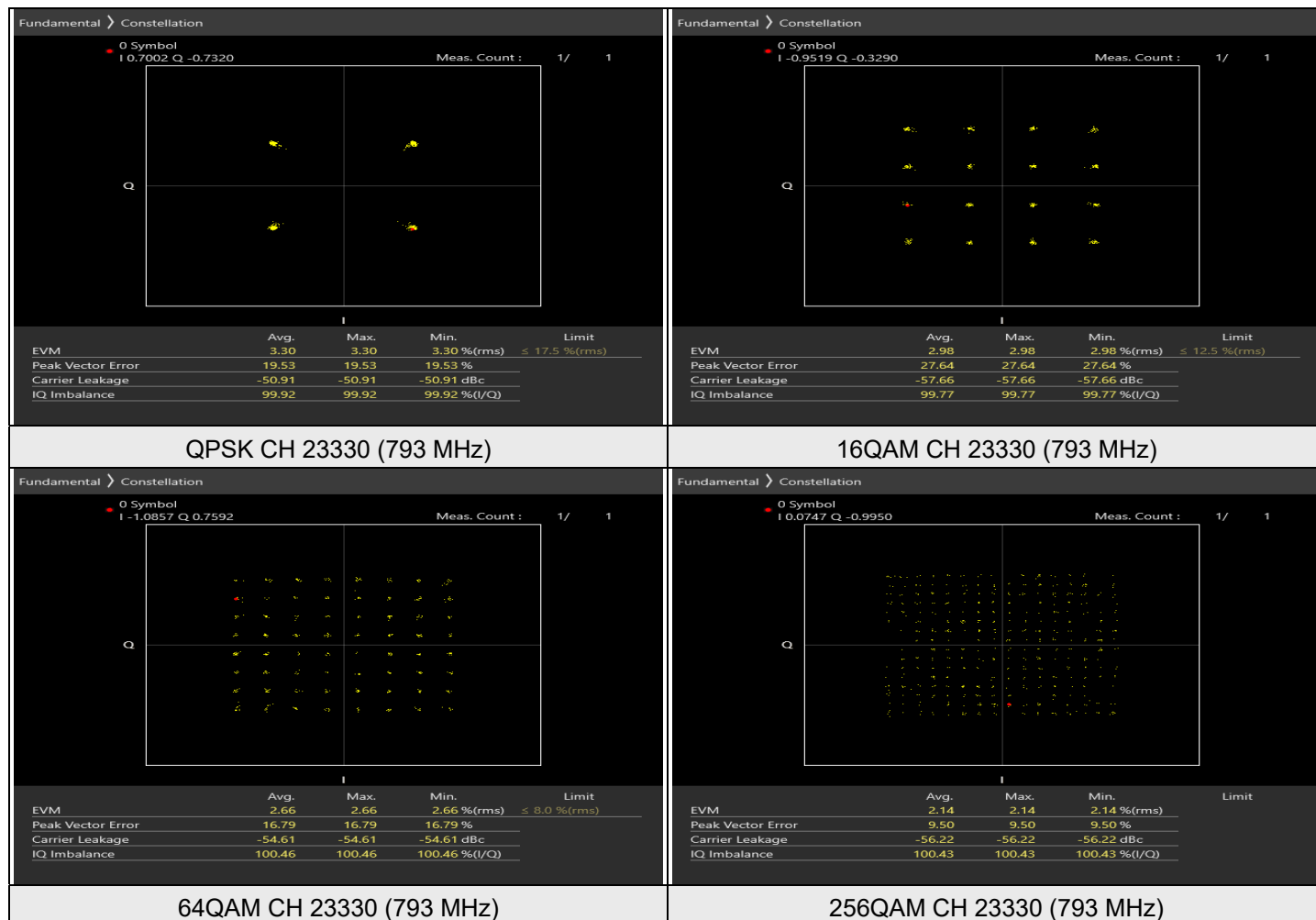



## 7.2.6 LTE Band 30

### LTE Band 30, Channel Bandwidth: 10 MHz



## 7.2.7 LTE Band 66

### LTE Band 66, Channel Bandwidth: 20 MHz

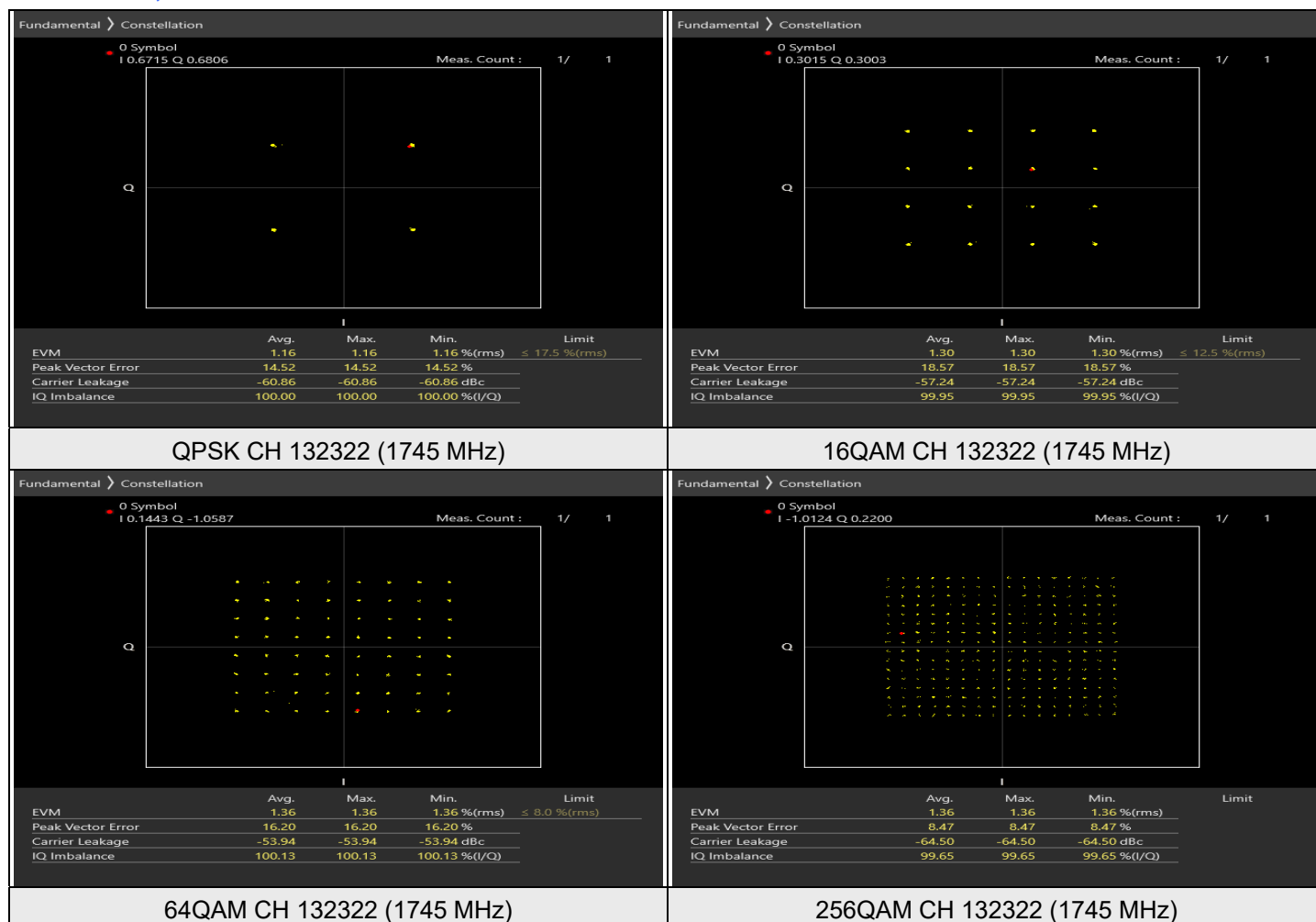

### 7.3 Peak to Average Ratio

Input Power:	120 Vac, 60 Hz	Environmental Conditions:	22°C, 74% RH	Tested By:	Willy Cheng
--------------	----------------	---------------------------	--------------	------------	-------------

#### 7.3.1 LTE Band 2

#### LTE Band 2, Channel Bandwidth: 1.4 MHz

Modulation	Channel	Frequency (MHz)	Measurement Value(dB)	Limit (dB)	Result
QPSK	18607	1850.7	4.96	13	PASS
QPSK	18900	1880	5.35	13	PASS
QPSK	19193	1909.3	4.80	13	PASS
16QAM	18607	1850.7	6.05	13	PASS
16QAM	18900	1880	6.40	13	PASS
16QAM	19193	1909.3	5.71	13	PASS
64QAM	18607	1850.7	6.59	13	PASS
64QAM	18900	1880	6.65	13	PASS
64QAM	19193	1909.3	6.29	13	PASS
256QAM	18607	1850.7	7.09	13	PASS
256QAM	18900	1880	7.53	13	PASS
256QAM	19193	1909.3	7.61	13	PASS

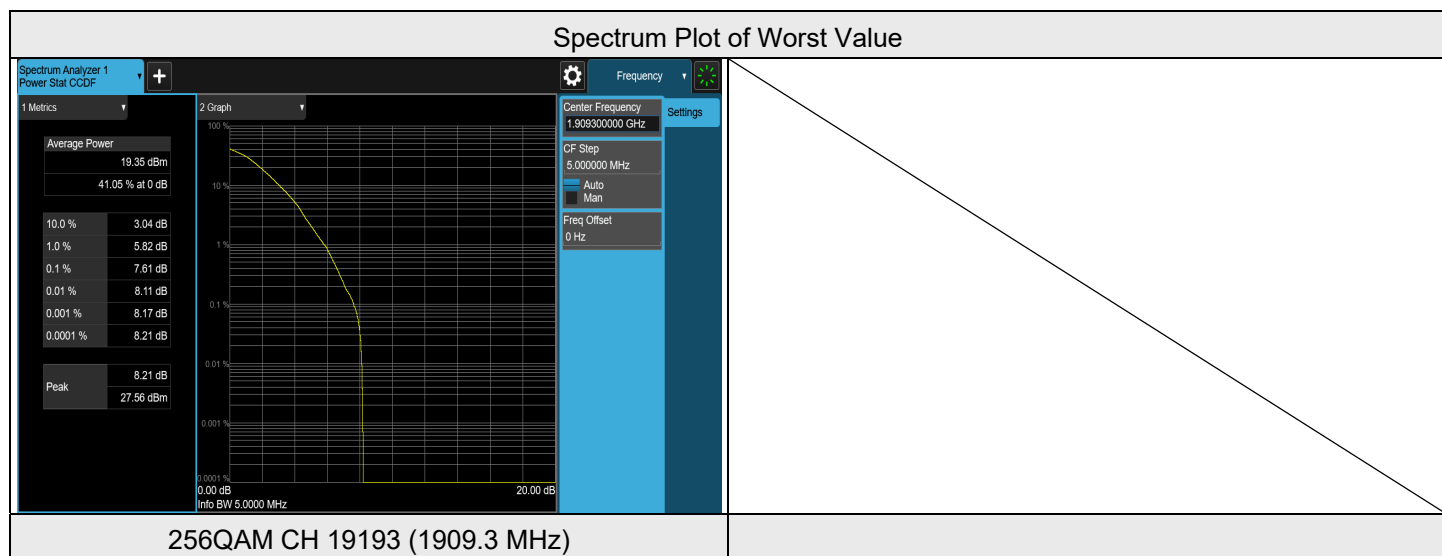

### LTE Band 2, Channel Bandwidth: 3 MHz

Modulation	Channel	Frequency (MHz)	Measurement Value(dB)	Limit (dB)	Result
QPSK	18615	1851.5	4.78	13	PASS
QPSK	18900	1880	5.29	13	PASS
QPSK	19185	1908.5	4.44	13	PASS
16QAM	18615	1851.5	5.67	13	PASS
16QAM	18900	1880	6.21	13	PASS
16QAM	19185	1908.5	5.36	13	PASS
64QAM	18615	1851.5	6.33	13	PASS
64QAM	18900	1880	6.25	13	PASS
64QAM	19185	1908.5	6.09	13	PASS
256QAM	18615	1851.5	6.40	13	PASS
256QAM	18900	1880	6.09	13	PASS
256QAM	19185	1908.5	7.16	13	PASS

Spectrum Plot of Worst Value

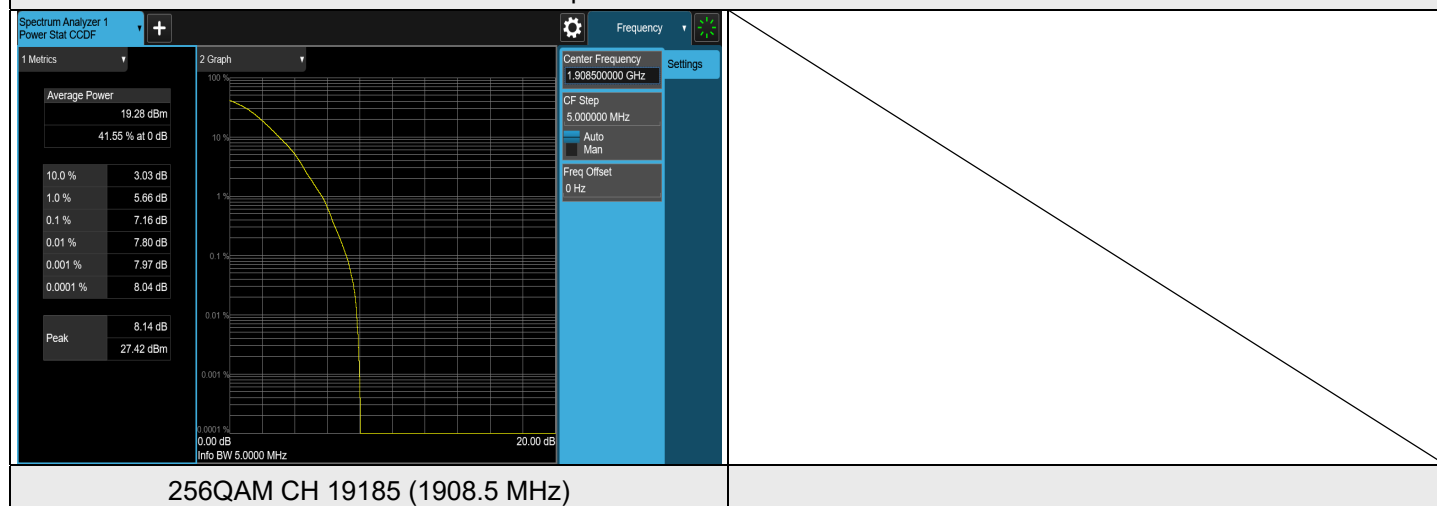

### LTE Band 2, Channel Bandwidth: 5 MHz

Modulation	Channel	Frequency (MHz)	Measurement Value(dB)	Limit (dB)	Result
QPSK	18625	1852.5	5.05	13	PASS
QPSK	18900	1880	5.34	13	PASS
QPSK	19175	1907.5	4.89	13	PASS
16QAM	18625	1852.5	6.05	13	PASS
16QAM	18900	1880	6.41	13	PASS
16QAM	19175	1907.5	5.78	13	PASS
64QAM	18625	1852.5	6.50	13	PASS
64QAM	18900	1880	6.70	13	PASS
64QAM	19175	1907.5	6.40	13	PASS
256QAM	18625	1852.5	7.10	13	PASS
256QAM	18900	1880	7.32	13	PASS
256QAM	19175	1907.5	7.42	13	PASS

Spectrum Plot of Worst Value

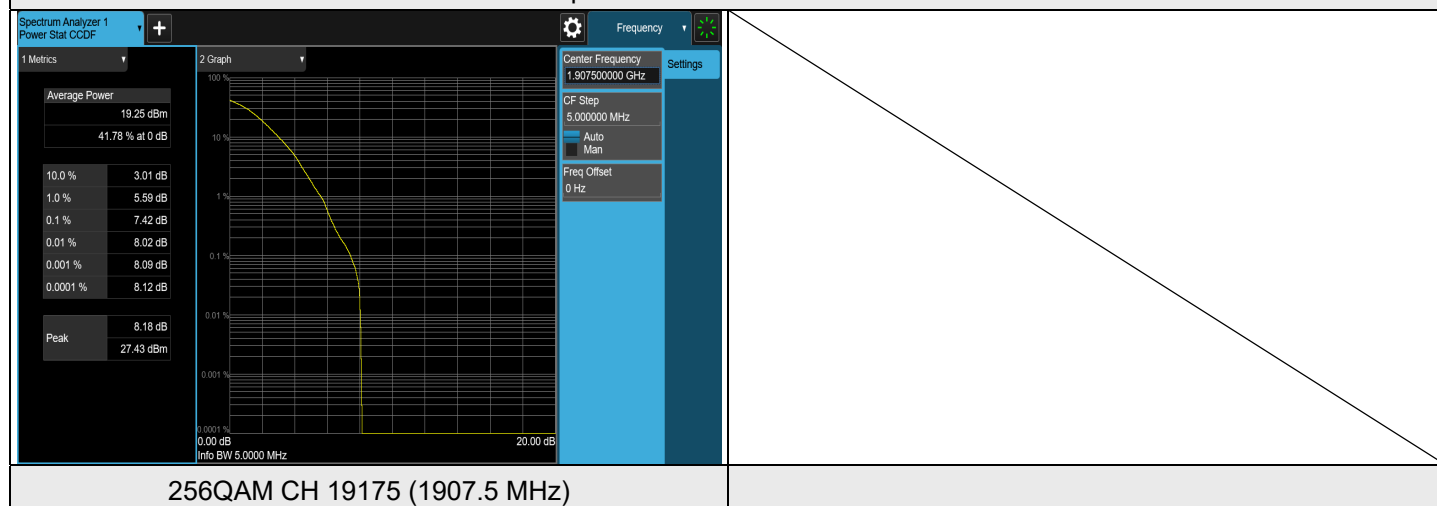

LTE Band 2, Channel Bandwidth: 10 MHz

Modulation	Channel	Frequency (MHz)	Measurement Value(dB)	Limit (dB)	Result
QPSK	18650	1855	5.07	13	PASS
QPSK	18900	1880	5.39	13	PASS
QPSK	19150	1905	5.24	13	PASS
16QAM	18650	1855	6.09	13	PASS
16QAM	18900	1880	6.42	13	PASS
16QAM	19150	1905	6.21	13	PASS
64QAM	18650	1855	6.51	13	PASS
64QAM	18900	1880	6.69	13	PASS
64QAM	19150	1905	6.56	13	PASS
256QAM	18650	1855	7.06	13	PASS
256QAM	18900	1880	7.21	13	PASS
256QAM	19150	1905	7.47	13	PASS

Spectrum Plot of Worst Value

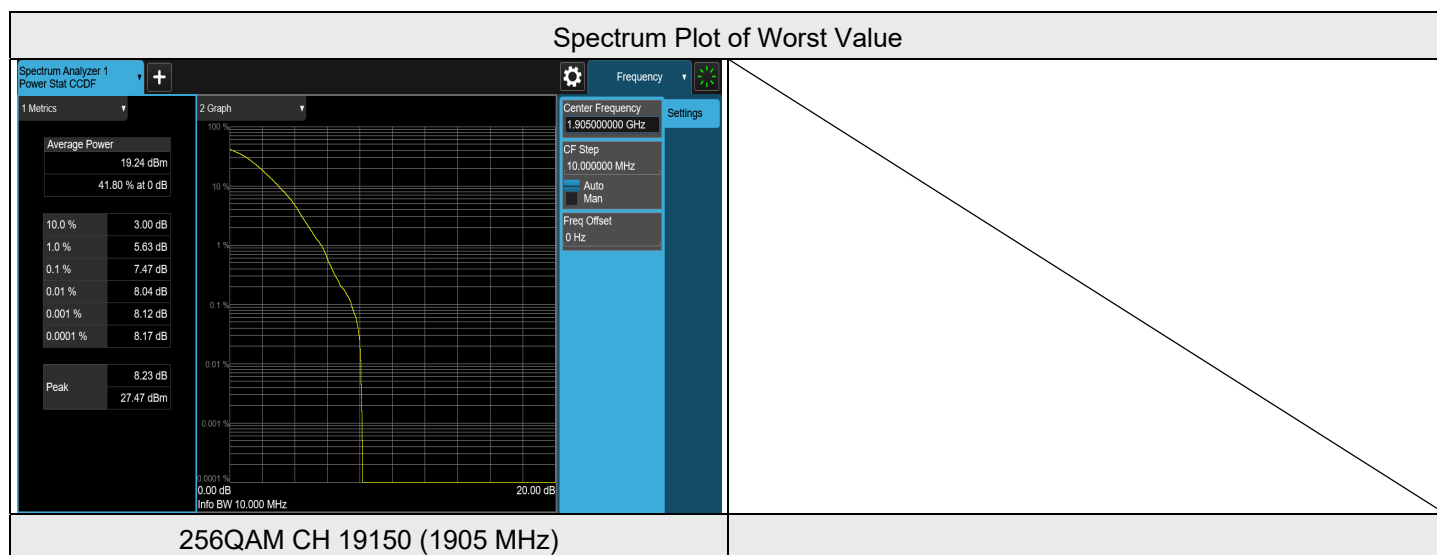

LTE Band 2, Channel Bandwidth: 15 MHz

Modulation	Channel	Frequency (MHz)	Measurement Value(dB)	Limit (dB)	Result
QPSK	18675	1857.5	5.07	13	PASS
QPSK	18900	1880	5.44	13	PASS
QPSK	19125	1902.5	5.02	13	PASS
16QAM	18675	1857.5	6.30	13	PASS
16QAM	18900	1880	6.54	13	PASS
16QAM	19125	1902.5	5.84	13	PASS
64QAM	18675	1857.5	6.65	13	PASS
64QAM	18900	1880	6.64	13	PASS
64QAM	19125	1902.5	6.59	13	PASS
256QAM	18675	1857.5	6.58	13	PASS
256QAM	18900	1880	6.58	13	PASS
256QAM	19125	1902.5	6.89	13	PASS

Spectrum Plot of Worst Value

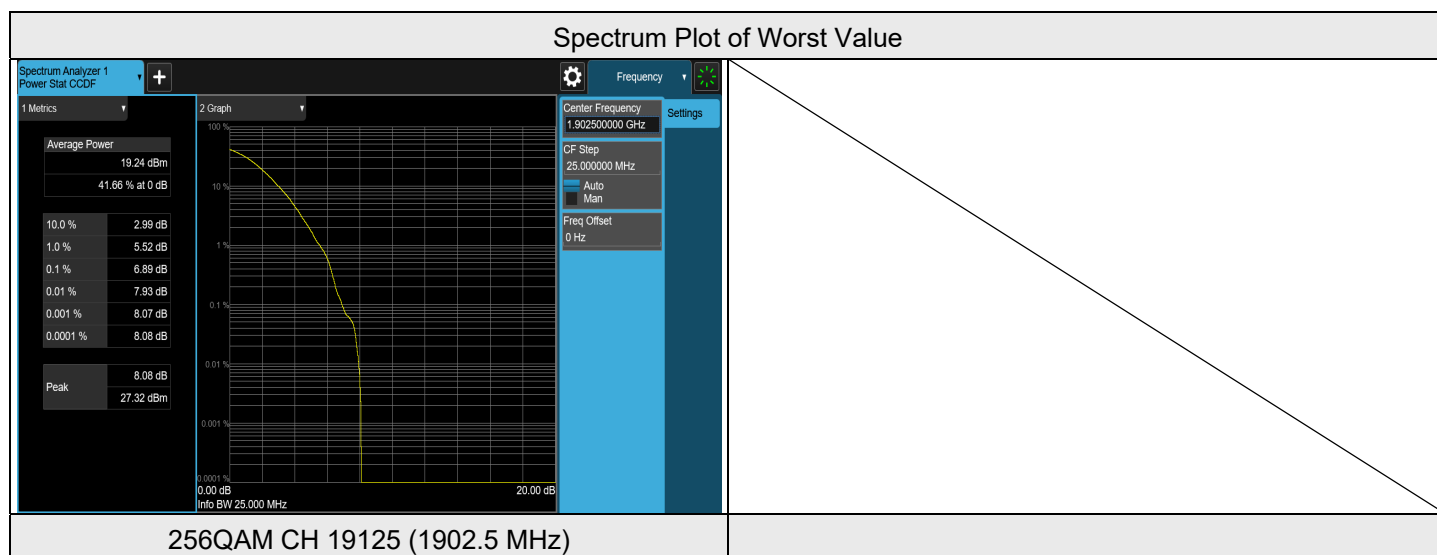

256QAM CH 19125 (1902.5 MHz)

LTE Band 2, Channel Bandwidth: 20 MHz

Modulation	Channel	Frequency (MHz)	Measurement Value(dB)	Limit (dB)	Result
QPSK	18700	1860	5.13	13	PASS
QPSK	18900	1880	5.28	13	PASS
QPSK	19100	1900	4.34	13	PASS
16QAM	18700	1860	5.99	13	PASS
16QAM	18900	1880	6.14	13	PASS
16QAM	19100	1900	5.15	13	PASS
64QAM	18700	1860	6.62	13	PASS
64QAM	18900	1880	6.56	13	PASS
64QAM	19100	1900	6.12	13	PASS
256QAM	18700	1860	7.03	13	PASS
256QAM	18900	1880	6.15	13	PASS
256QAM	19100	1900	7.33	13	PASS

Spectrum Plot of Worst Value

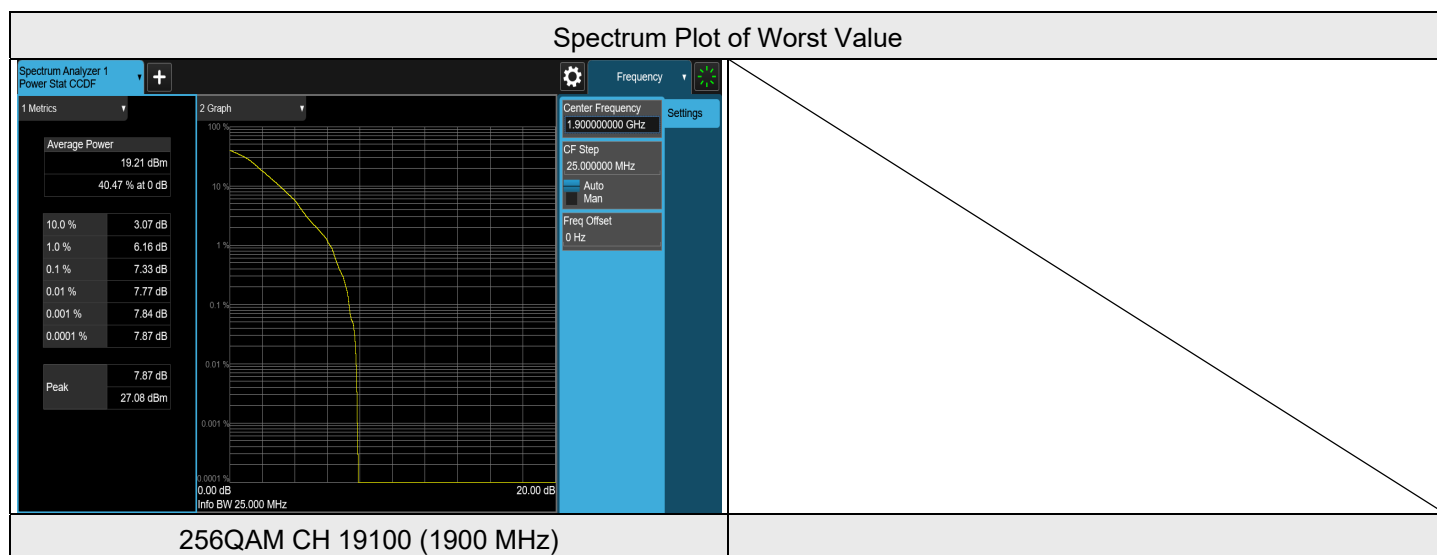



### 7.3.2 LTE Band 4

#### LTE Band 4, Channel Bandwidth: 1.4 MHz

Modulation	Channel	Frequency (MHz)	Measurement Value(dB)	Limit (dB)	Result
QPSK	19957	1710.7	4.53	13	PASS
QPSK	20175	1732.5	4.64	13	PASS
QPSK	20393	1754.3	4.50	13	PASS
16QAM	19957	1710.7	5.49	13	PASS
16QAM	20175	1732.5	5.59	13	PASS
16QAM	20393	1754.3	5.39	13	PASS
64QAM	19957	1710.7	5.94	13	PASS
64QAM	20175	1732.5	6.16	13	PASS
64QAM	20393	1754.3	6.00	13	PASS
256QAM	19957	1710.7	7.24	13	PASS
256QAM	20175	1732.5	7.16	13	PASS
256QAM	20393	1754.3	7.32	13	PASS

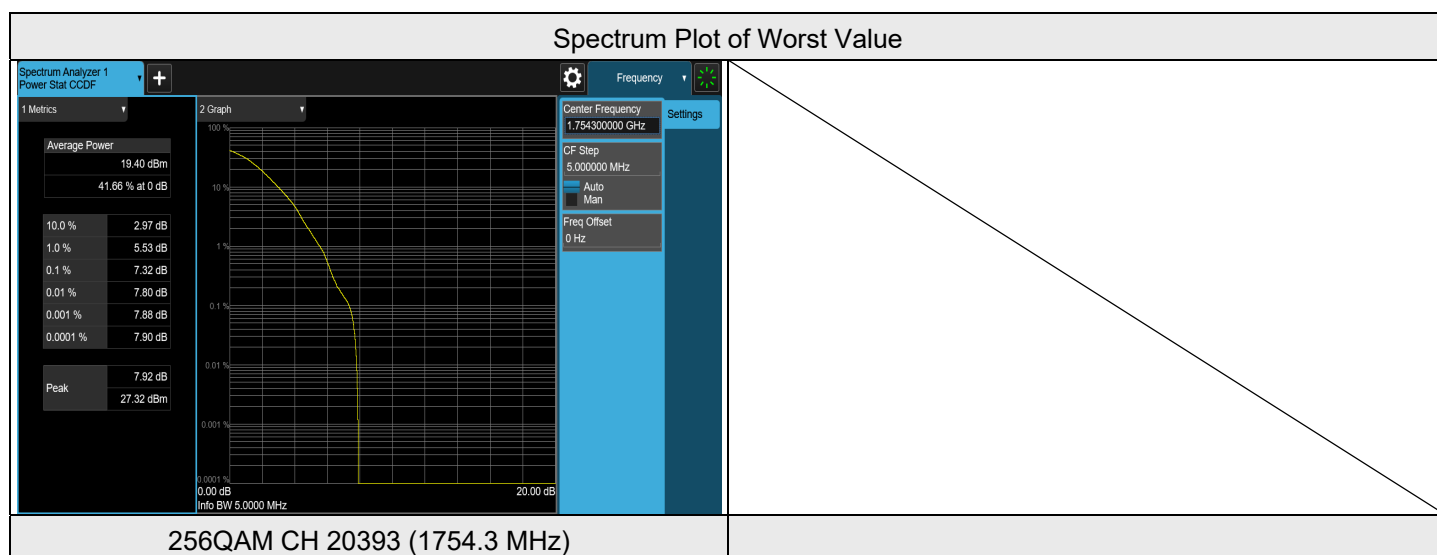

LTE Band 4, Channel Bandwidth: 3 MHz

Modulation	Channel	Frequency (MHz)	Measurement Value(dB)	Limit (dB)	Result
QPSK	19965	1711.5	4.35	13	PASS
QPSK	20175	1732.5	4.52	13	PASS
QPSK	20385	1753.5	4.09	13	PASS
16QAM	19965	1711.5	4.85	13	PASS
16QAM	20175	1732.5	5.36	13	PASS
16QAM	20385	1753.5	4.95	13	PASS
64QAM	19965	1711.5	5.58	13	PASS
64QAM	20175	1732.5	5.90	13	PASS
64QAM	20385	1753.5	5.64	13	PASS
256QAM	19965	1711.5	6.78	13	PASS
256QAM	20175	1732.5	5.30	13	PASS
256QAM	20385	1753.5	7.11	13	PASS

Spectrum Plot of Worst Value

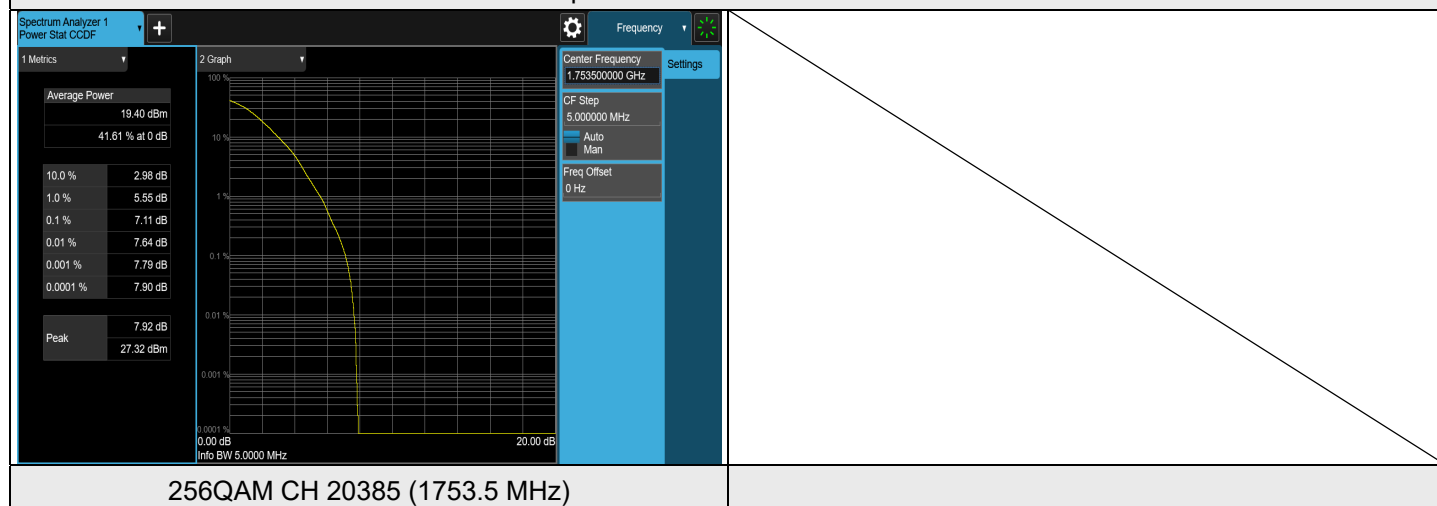

LTE Band 4, Channel Bandwidth: 5 MHz

Modulation	Channel	Frequency (MHz)	Measurement Value(dB)	Limit (dB)	Result
QPSK	19975	1712.5	4.40	13	PASS
QPSK	20175	1732.5	4.55	13	PASS
QPSK	20375	1752.5	4.37	13	PASS
16QAM	19975	1712.5	5.42	13	PASS
16QAM	20175	1732.5	5.47	13	PASS
16QAM	20375	1752.5	5.29	13	PASS
64QAM	19975	1712.5	5.86	13	PASS
64QAM	20175	1732.5	6.14	13	PASS
64QAM	20375	1752.5	5.85	13	PASS
256QAM	19975	1712.5	7.20	13	PASS
256QAM	20175	1732.5	7.00	13	PASS
256QAM	20375	1752.5	7.13	13	PASS

Spectrum Plot of Worst Value

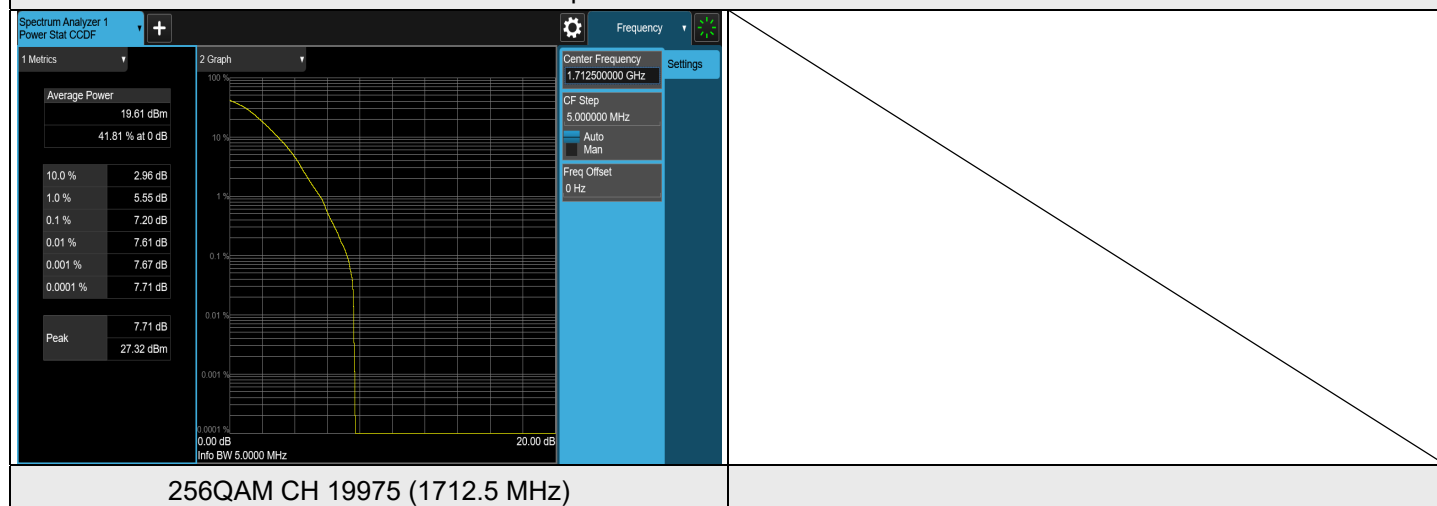

LTE Band 4, Channel Bandwidth: 10 MHz

Modulation	Channel	Frequency (MHz)	Measurement Value(dB)	Limit (dB)	Result
QPSK	20000	1715	4.40	13	PASS
QPSK	20175	1732.5	4.46	13	PASS
QPSK	20350	1750	4.62	13	PASS
16QAM	20000	1715	5.37	13	PASS
16QAM	20175	1732.5	5.37	13	PASS
16QAM	20350	1750	5.61	13	PASS
64QAM	20000	1715	5.85	13	PASS
64QAM	20175	1732.5	6.06	13	PASS
64QAM	20350	1750	6.01	13	PASS
256QAM	20000	1715	7.35	13	PASS
256QAM	20175	1732.5	7.35	13	PASS
256QAM	20350	1750	7.41	13	PASS

Spectrum Plot of Worst Value

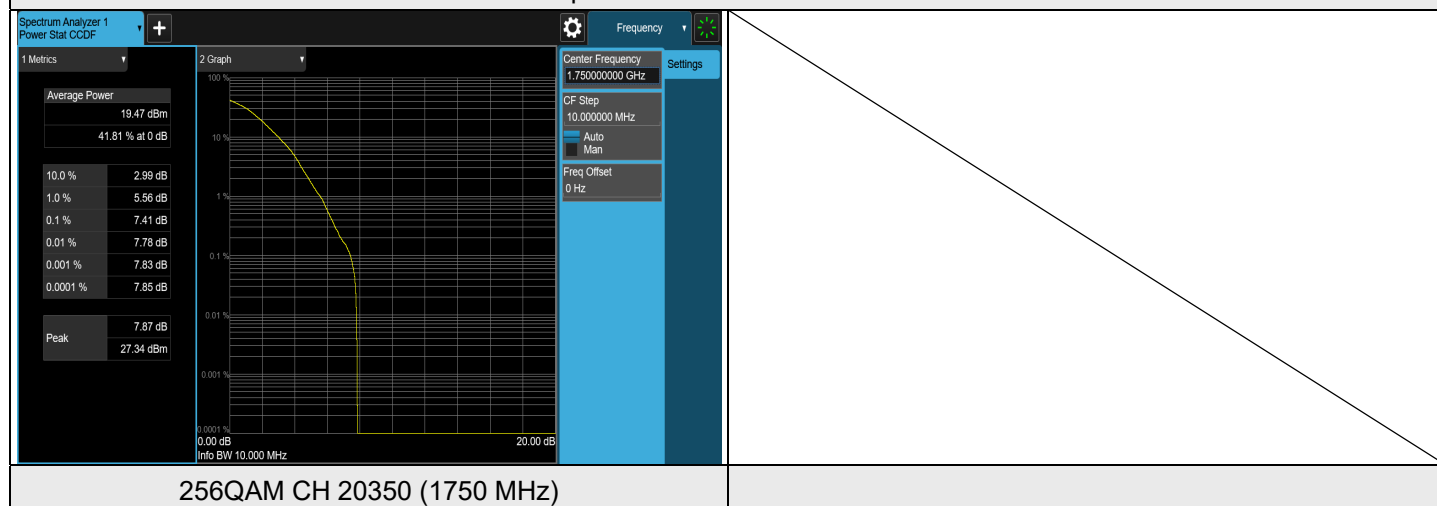

### LTE Band 4, Channel Bandwidth: 15 MHz

Modulation	Channel	Frequency (MHz)	Measurement Value(dB)	Limit (dB)	Result
QPSK	20025	1717.5	4.32	13	PASS
QPSK	20175	1732.5	4.46	13	PASS
QPSK	20325	1747.5	4.87	13	PASS
16QAM	20025	1717.5	5.43	13	PASS
16QAM	20175	1732.5	5.30	13	PASS
16QAM	20325	1747.5	5.76	13	PASS
64QAM	20025	1717.5	5.73	13	PASS
64QAM	20175	1732.5	5.99	13	PASS
64QAM	20325	1747.5	6.41	13	PASS
256QAM	20025	1717.5	6.97	13	PASS
256QAM	20175	1732.5	6.92	13	PASS
256QAM	20325	1747.5	7.39	13	PASS

Spectrum Plot of Worst Value

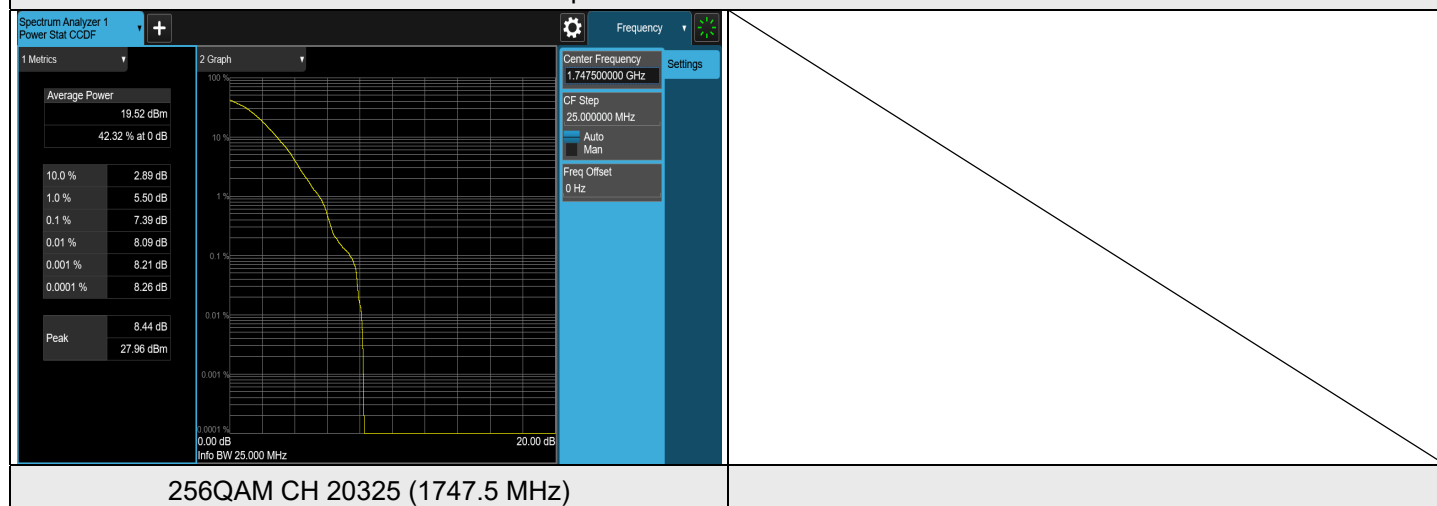

LTE Band 4, Channel Bandwidth: 20 MHz

Modulation	Channel	Frequency (MHz)	Measurement Value(dB)	Limit (dB)	Result
QPSK	20050	1720	4.24	13	PASS
QPSK	20175	1732.5	4.35	13	PASS
QPSK	20300	1745	4.71	13	PASS
16QAM	20050	1720	5.19	13	PASS
16QAM	20175	1732.5	5.31	13	PASS
16QAM	20300	1745	5.60	13	PASS
64QAM	20050	1720	5.85	13	PASS
64QAM	20175	1732.5	6.39	13	PASS
64QAM	20300	1745	6.43	13	PASS
256QAM	20050	1720	7.28	13	PASS
256QAM	20175	1732.5	7.27	13	PASS
256QAM	20300	1745	6.65	13	PASS

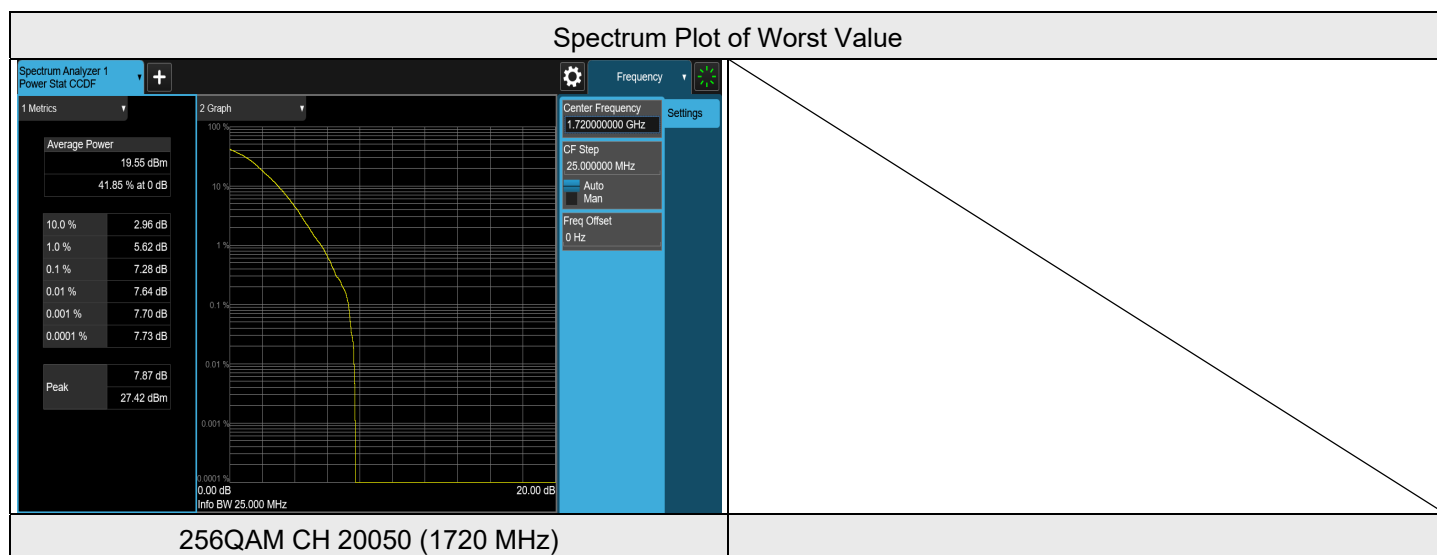

### 7.3.3 LTE Band 5

#### LTE Band 5, Channel Bandwidth: 1.4 MHz

Modulation	Channel	Frequency (MHz)	Measurement Value(dB)	Limit (dB)	Result
QPSK	20407	824.7	5.07	13	PASS
QPSK	20525	836.5	3.64	13	PASS
QPSK	20643	848.3	4.43	13	PASS
16QAM	20407	824.7	6.22	13	PASS
16QAM	20525	836.5	4.60	13	PASS
16QAM	20643	848.3	5.38	13	PASS
64QAM	20407	824.7	6.10	13	PASS
64QAM	20525	836.5	5.13	13	PASS
64QAM	20643	848.3	5.70	13	PASS
256QAM	20407	824.7	6.89	13	PASS
256QAM	20525	836.5	6.31	13	PASS
256QAM	20643	848.3	6.44	13	PASS

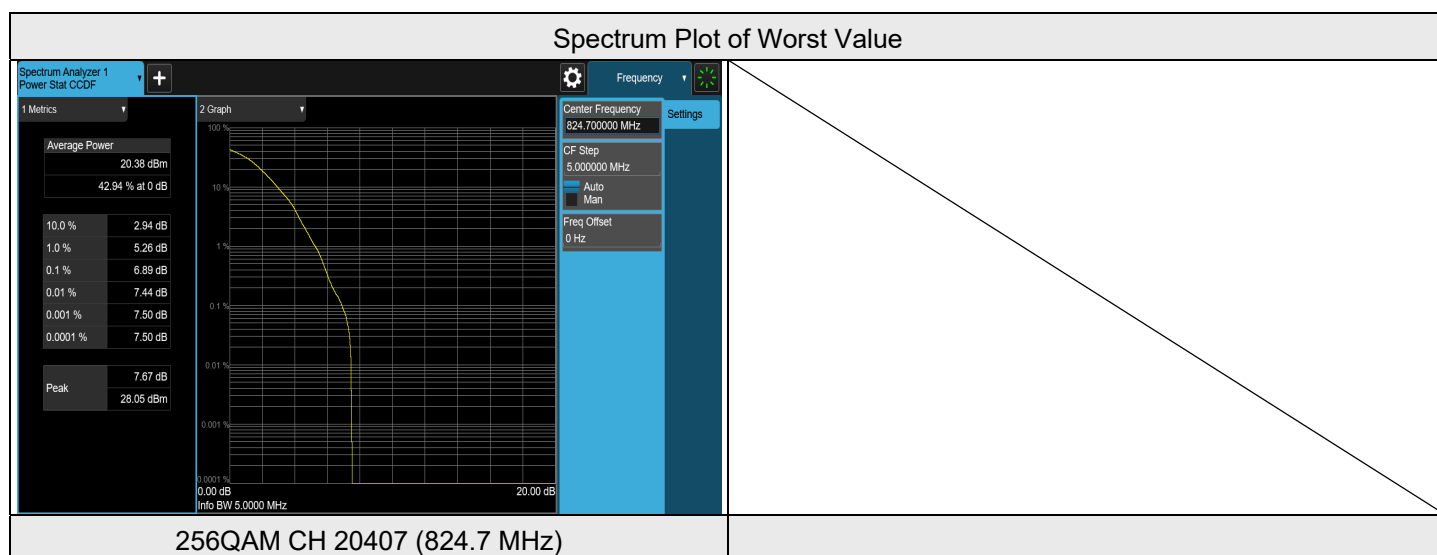

LTE Band 5, Channel Bandwidth: 3 MHz

Modulation	Channel	Frequency (MHz)	Measurement Value(dB)	Limit (dB)	Result
QPSK	20415	825.5	4.56	13	PASS
QPSK	20525	836.5	3.48	13	PASS
QPSK	20635	847.5	3.37	13	PASS
16QAM	20415	825.5	5.62	13	PASS
16QAM	20525	836.5	4.52	13	PASS
16QAM	20635	847.5	4.38	13	PASS
64QAM	20415	825.5	6.02	13	PASS
64QAM	20525	836.5	4.83	13	PASS
64QAM	20635	847.5	4.95	13	PASS
256QAM	20415	825.5	6.63	13	PASS
256QAM	20525	836.5	5.37	13	PASS
256QAM	20635	847.5	6.13	13	PASS

Spectrum Plot of Worst Value

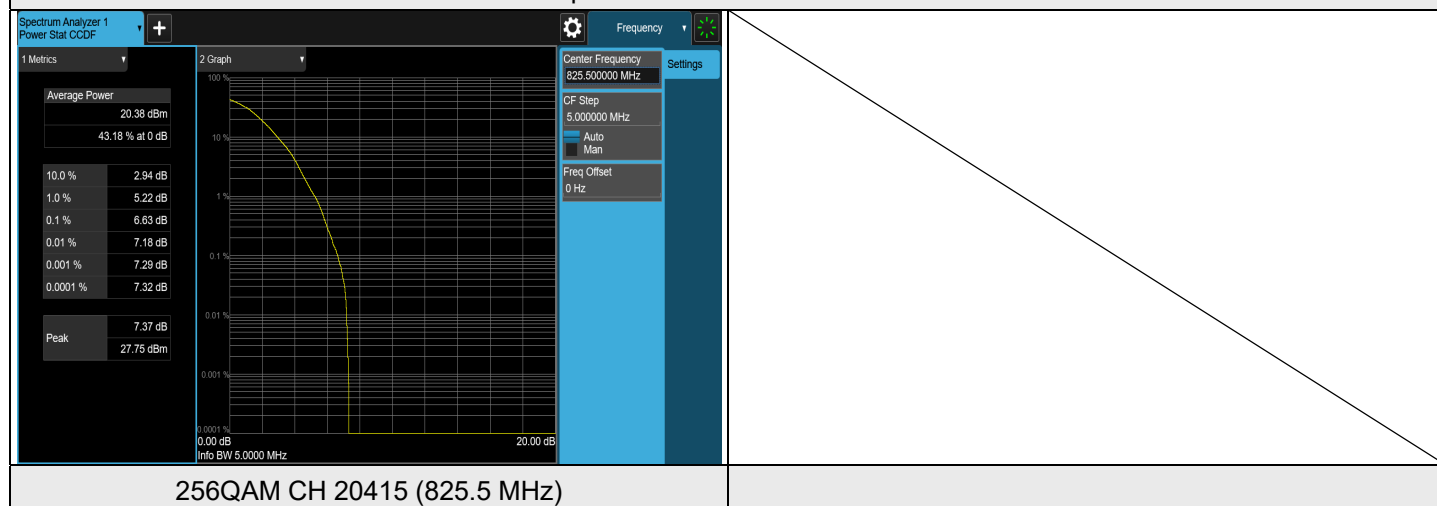



LTE Band 5, Channel Bandwidth: 5 MHz

Modulation	Channel	Frequency (MHz)	Measurement Value(dB)	Limit (dB)	Result
QPSK	20425	826.5	5.08	13	PASS
QPSK	20525	836.5	3.48	13	PASS
QPSK	20625	846.5	3.80	13	PASS
16QAM	20425	826.5	6.19	13	PASS
16QAM	20525	836.5	4.53	13	PASS
16QAM	20625	846.5	4.82	13	PASS
64QAM	20425	826.5	6.10	13	PASS
64QAM	20525	836.5	4.94	13	PASS
64QAM	20625	846.5	5.39	13	PASS
256QAM	20425	826.5	6.74	13	PASS
256QAM	20525	836.5	6.08	13	PASS
256QAM	20625	846.5	6.65	13	PASS

Spectrum Plot of Worst Value

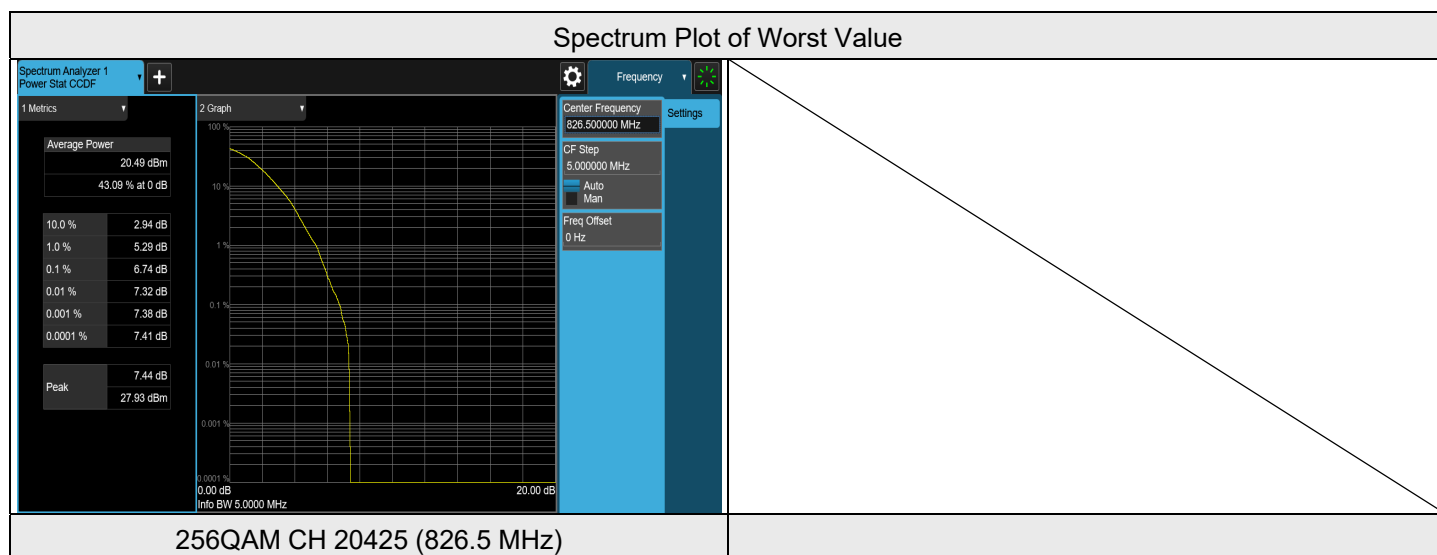

LTE Band 5, Channel Bandwidth: 10 MHz

Modulation	Channel	Frequency (MHz)	Measurement Value(dB)	Limit (dB)	Result
QPSK	20450	829	5.05	13	PASS
QPSK	20525	836.5	3.75	13	PASS
QPSK	20600	844	4.67	13	PASS
16QAM	20450	829	6.18	13	PASS
16QAM	20525	836.5	4.95	13	PASS
16QAM	20600	844	5.66	13	PASS
64QAM	20450	829	6.09	13	PASS
64QAM	20525	836.5	5.34	13	PASS
64QAM	20600	844	5.83	13	PASS
256QAM	20450	829	6.81	13	PASS
256QAM	20525	836.5	6.34	13	PASS
256QAM	20600	844	6.66	13	PASS

Spectrum Plot of Worst Value

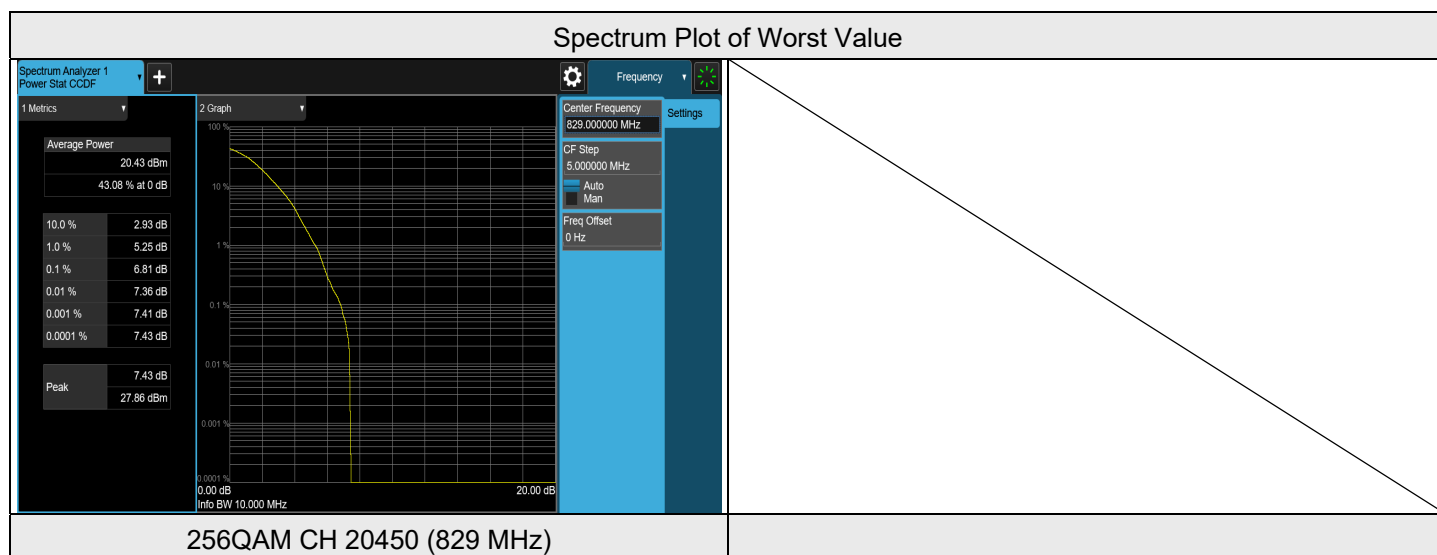

### 7.3.4 LTE Band 12

#### LTE Band 12, Channel Bandwidth: 1.4 MHz

Modulation	Channel	Frequency (MHz)	Measurement Value(dB)	Limit (dB)	Result
QPSK	23017	699.7	4.38	13	PASS
QPSK	23095	707.5	4.67	13	PASS
QPSK	23173	715.3	5.17	13	PASS
16QAM	23017	699.7	5.58	13	PASS
16QAM	23095	707.5	5.64	13	PASS
16QAM	23173	715.3	6.14	13	PASS
64QAM	23017	699.7	5.81	13	PASS
64QAM	23095	707.5	6.35	13	PASS
64QAM	23173	715.3	6.44	13	PASS
256QAM	23017	699.7	6.58	13	PASS
256QAM	23095	707.5	6.74	13	PASS
256QAM	23173	715.3	6.95	13	PASS

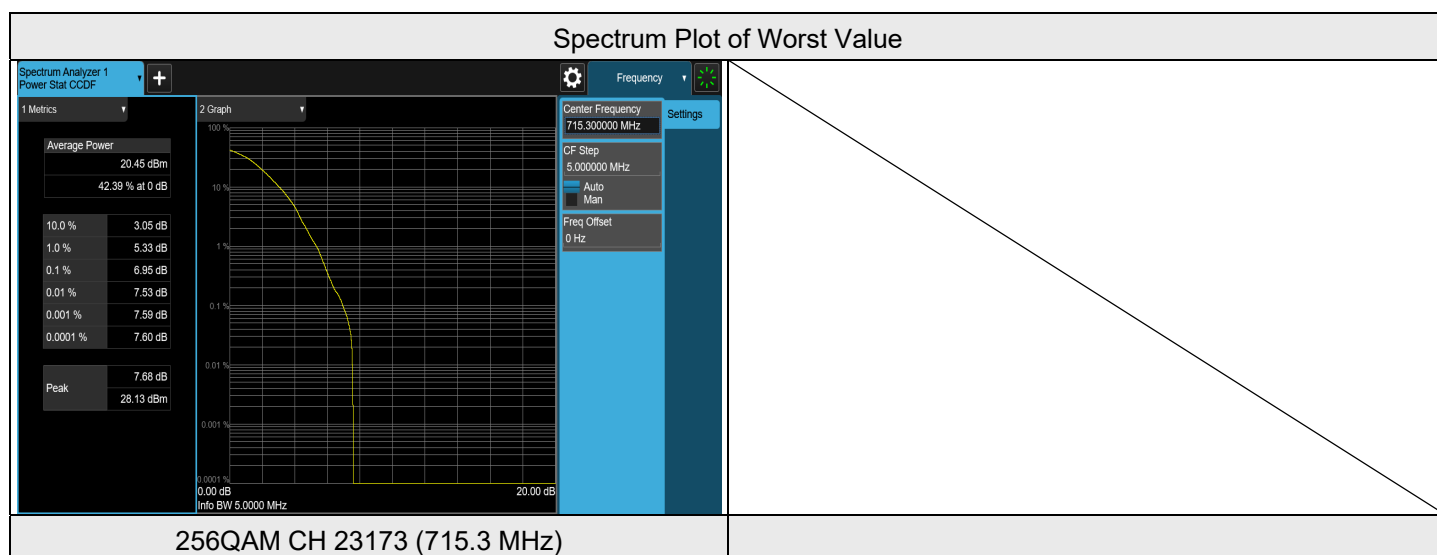

### LTE Band 12, Channel Bandwidth: 3 MHz

Modulation	Channel	Frequency (MHz)	Measurement Value(dB)	Limit (dB)	Result
QPSK	23025	700.5	4.52	13	PASS
QPSK	23095	707.5	4.50	13	PASS
QPSK	23165	714.5	4.34	13	PASS
16QAM	23025	700.5	5.45	13	PASS
16QAM	23095	707.5	5.47	13	PASS
16QAM	23165	714.5	5.31	13	PASS
64QAM	23025	700.5	5.82	13	PASS
64QAM	23095	707.5	6.31	13	PASS
64QAM	23165	714.5	5.81	13	PASS
256QAM	23025	700.5	6.51	13	PASS
256QAM	23095	707.5	6.67	13	PASS
256QAM	23165	714.5	6.31	13	PASS

Spectrum Plot of Worst Value

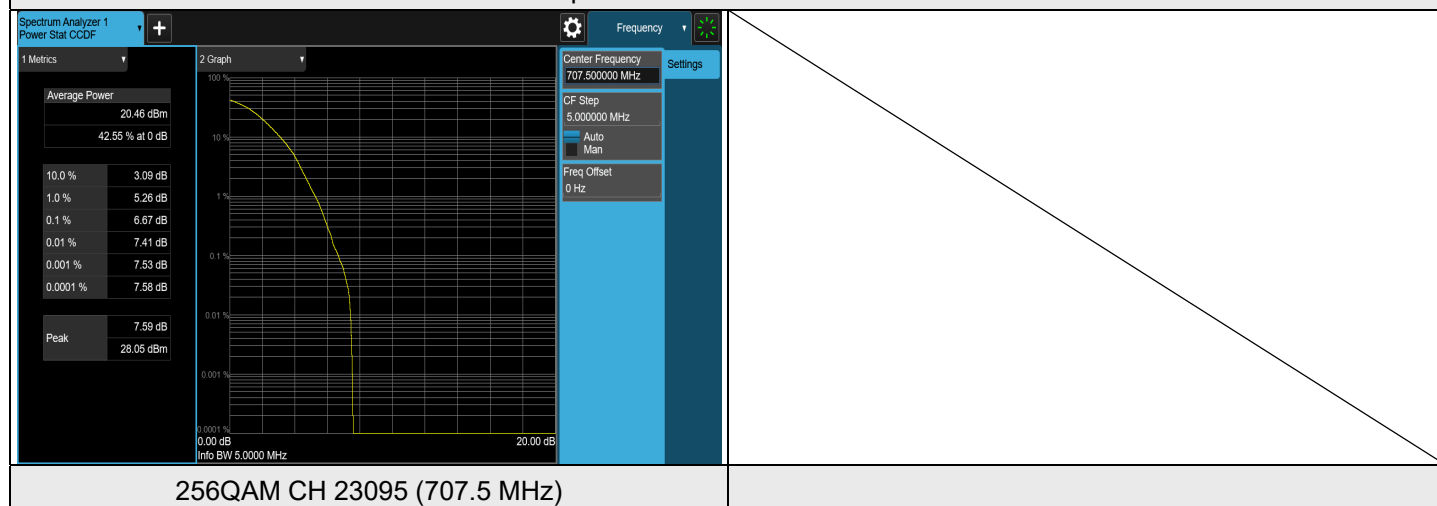

LTE Band 12, Channel Bandwidth: 5 MHz

Modulation	Channel	Frequency (MHz)	Measurement Value(dB)	Limit (dB)	Result
QPSK	23035	701.5	4.61	13	PASS
QPSK	23095	707.5	4.43	13	PASS
QPSK	23155	713.5	4.00	13	PASS
16QAM	23035	701.5	5.61	13	PASS
16QAM	23095	707.5	5.40	13	PASS
16QAM	23155	713.5	5.06	13	PASS
64QAM	23035	701.5	5.79	13	PASS
64QAM	23095	707.5	6.29	13	PASS
64QAM	23155	713.5	5.36	13	PASS
256QAM	23035	701.5	6.50	13	PASS
256QAM	23095	707.5	6.95	13	PASS
256QAM	23155	713.5	6.49	13	PASS

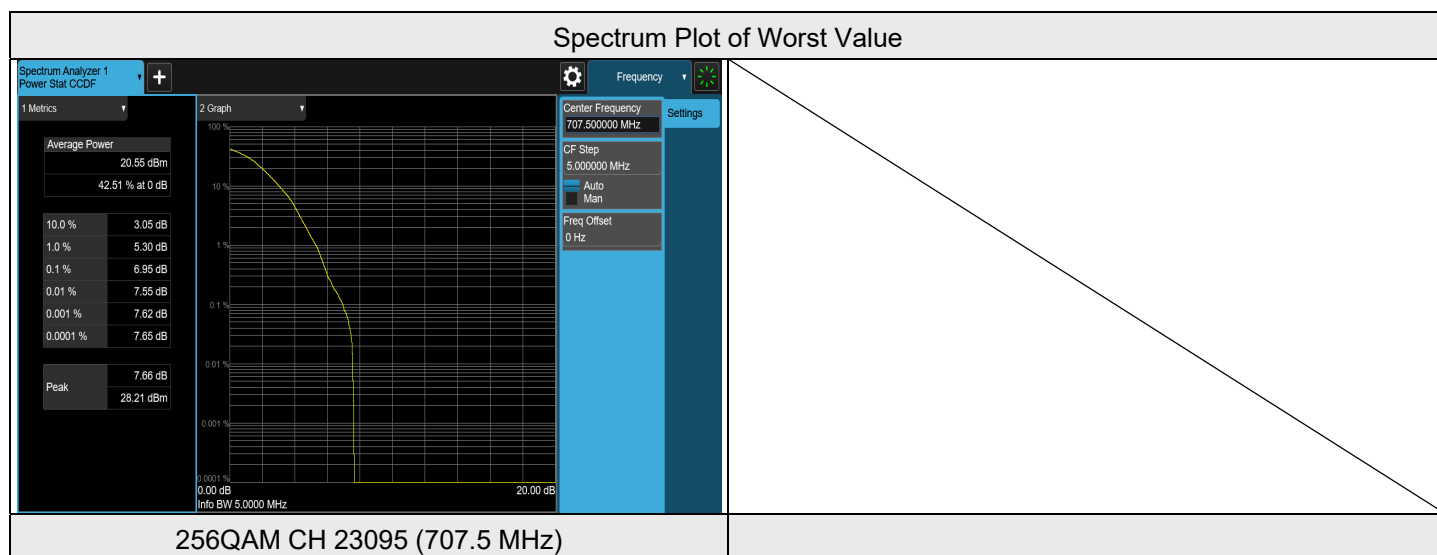

LTE Band 12, Channel Bandwidth: 10 MHz

Modulation	Channel	Frequency (MHz)	Measurement Value(dB)	Limit (dB)	Result
QPSK	23060	704	4.70	13	PASS
QPSK	23095	707.5	4.81	13	PASS
QPSK	23130	711	4.57	13	PASS
16QAM	23060	704	5.70	13	PASS
16QAM	23095	707.5	5.84	13	PASS
16QAM	23130	711	5.58	13	PASS
64QAM	23060	704	5.95	13	PASS
64QAM	23095	707.5	6.62	13	PASS
64QAM	23130	711	6.34	13	PASS
256QAM	23060	704	6.51	13	PASS
256QAM	23095	707.5	7.06	13	PASS
256QAM	23130	711	7.00	13	PASS

Spectrum Plot of Worst Value

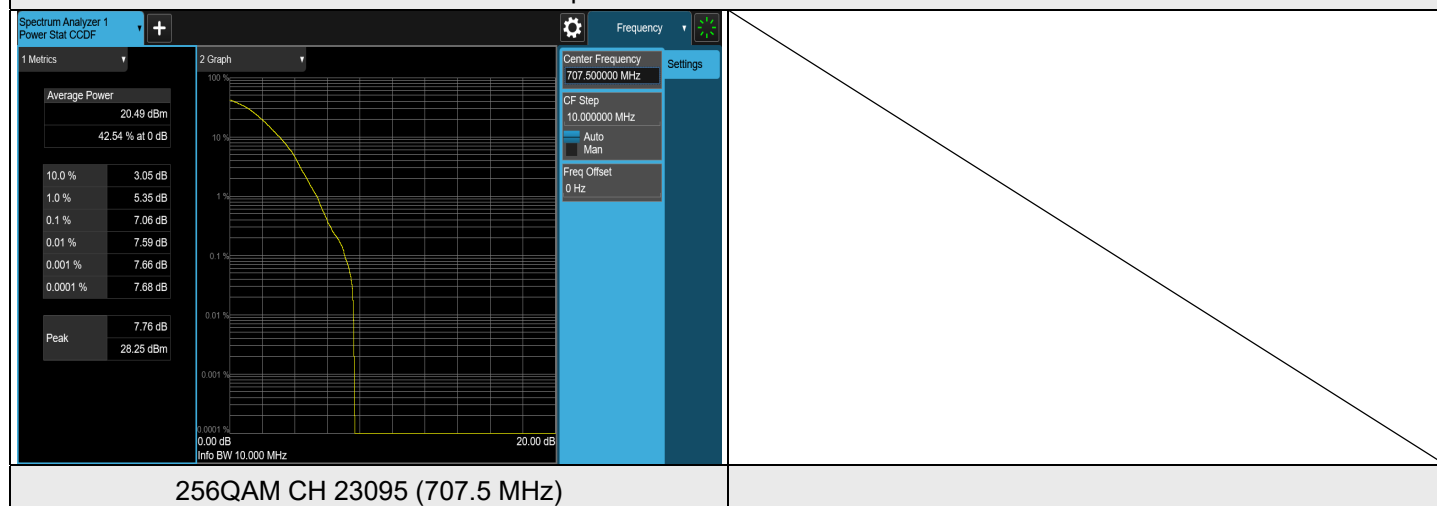

7.3.5 LTE Band 14

LTE Band 14, Channel Bandwidth: 5 MHz

Modulation	Channel	Frequency (MHz)	Measurement Value(dB)	Limit (dB)	Result
QPSK	23305	790.5	2.39	13	PASS
QPSK	23330	793	3.37	13	PASS
QPSK	23355	795.5	4.77	13	PASS
16QAM	23305	790.5	3.37	13	PASS
16QAM	23330	793	4.24	13	PASS
16QAM	23355	795.5	5.84	13	PASS
64QAM	23305	790.5	3.80	13	PASS
64QAM	23330	793	4.72	13	PASS
64QAM	23355	795.5	5.79	13	PASS
256QAM	23305	790.5	5.26	13	PASS
256QAM	23330	793	5.93	13	PASS
256QAM	23355	795.5	6.65	13	PASS

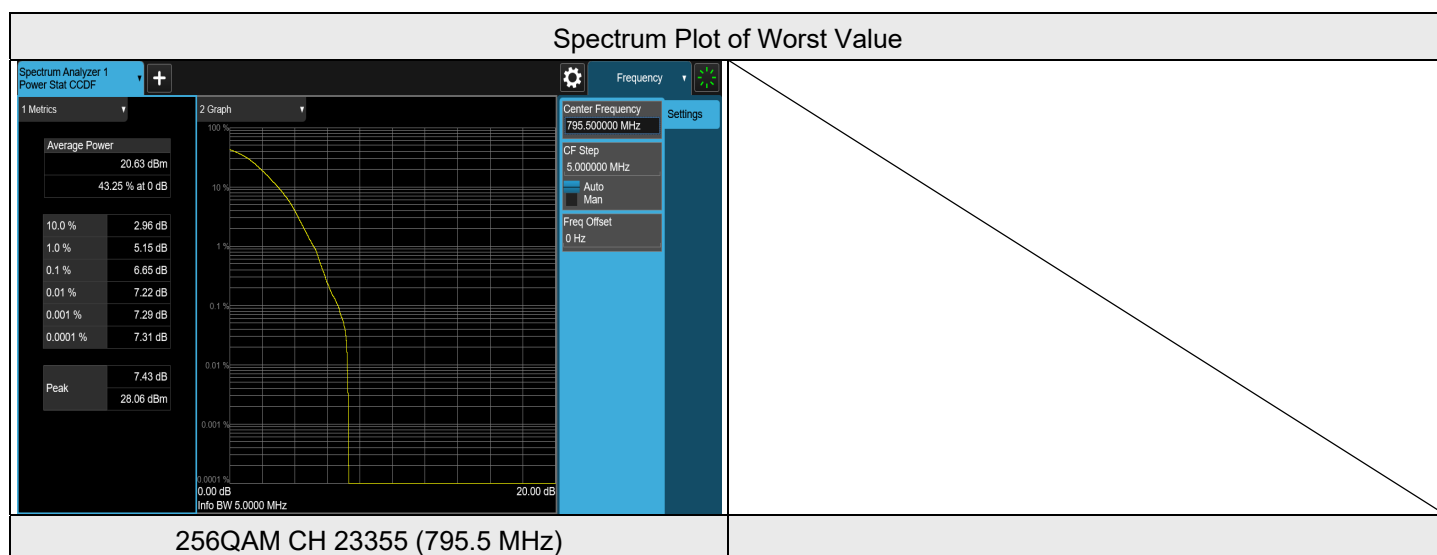

**LTE Band 14, Channel Bandwidth: 10 MHz**

Modulation	Channel	Frequency (MHz)	Measurement Value(dB)	Limit (dB)	Result
QPSK	23330	793	2.43	13	PASS
16QAM	23330	793	3.34	13	PASS
64QAM	23330	793	3.83	13	PASS
256QAM	23330	793	5.34	13	PASS

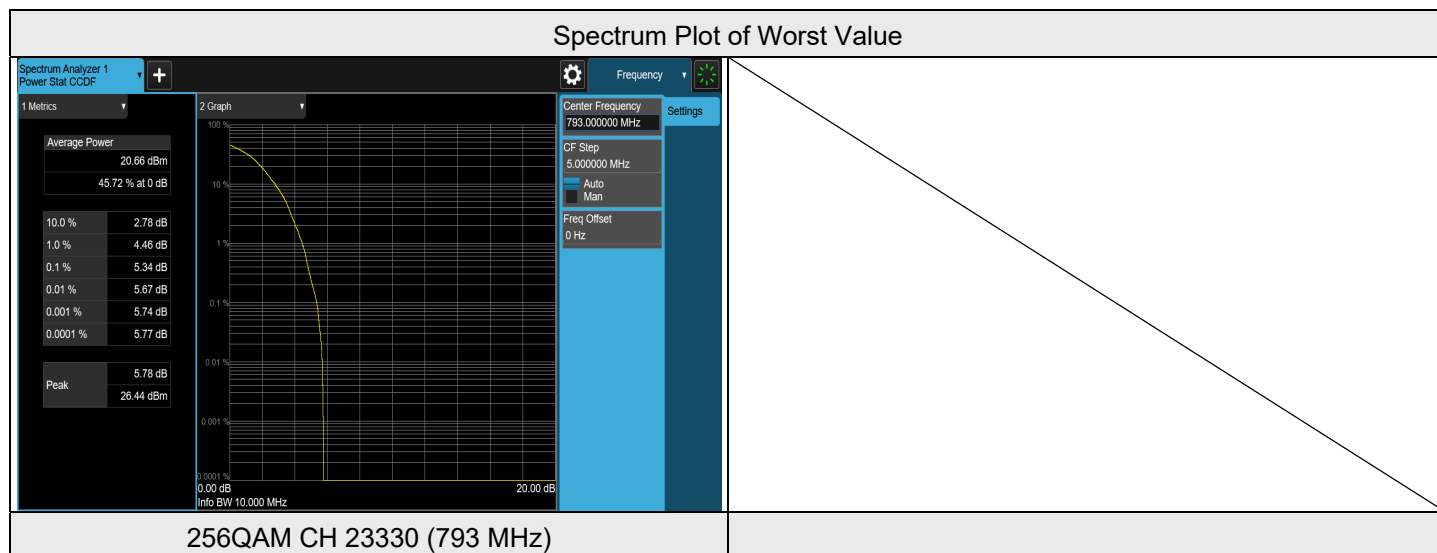



7.3.6 LTE Band 30

LTE Band 30, Channel Bandwidth: 5 MHz

Modulation	Channel	Frequency (MHz)	Measurement Value(dB)	Limit (dB)	Result
QPSK	27685	2307.5	4.36	13	PASS
QPSK	27710	2310	4.22	13	PASS
QPSK	27735	2312.5	4.05	13	PASS
16QAM	27685	2307.5	5.39	13	PASS
16QAM	27710	2310	5.30	13	PASS
16QAM	27735	2312.5	5.16	13	PASS
64QAM	27685	2307.5	5.76	13	PASS
64QAM	27710	2310	5.69	13	PASS
64QAM	27735	2312.5	5.44	13	PASS
256QAM	27685	2307.5	7.10	13	PASS
256QAM	27710	2310	6.87	13	PASS
256QAM	27735	2312.5	7.19	13	PASS

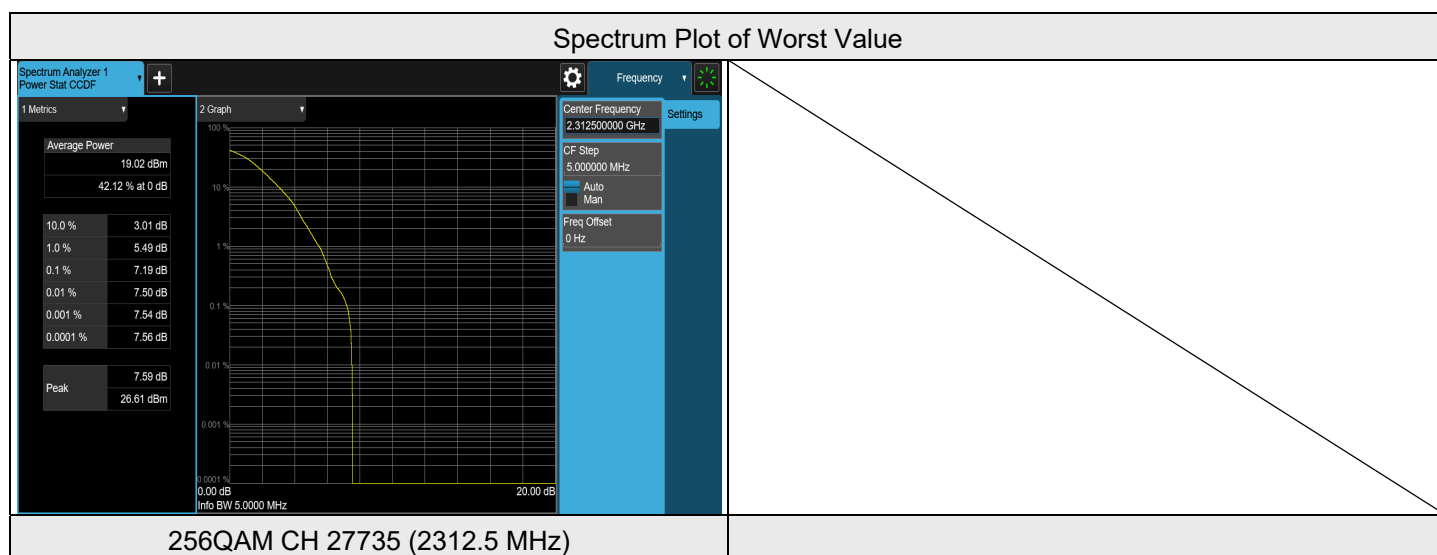

LTE Band 30, Channel Bandwidth: 10 MHz

Modulation	Channel	Frequency (MHz)	Measurement Value(dB)	Limit (dB)	Result
QPSK	27710	2310	4.36	13	PASS
16QAM	27710	2310	5.40	13	PASS
64QAM	27710	2310	5.90	13	PASS
256QAM	27710	2310	7.03	13	PASS

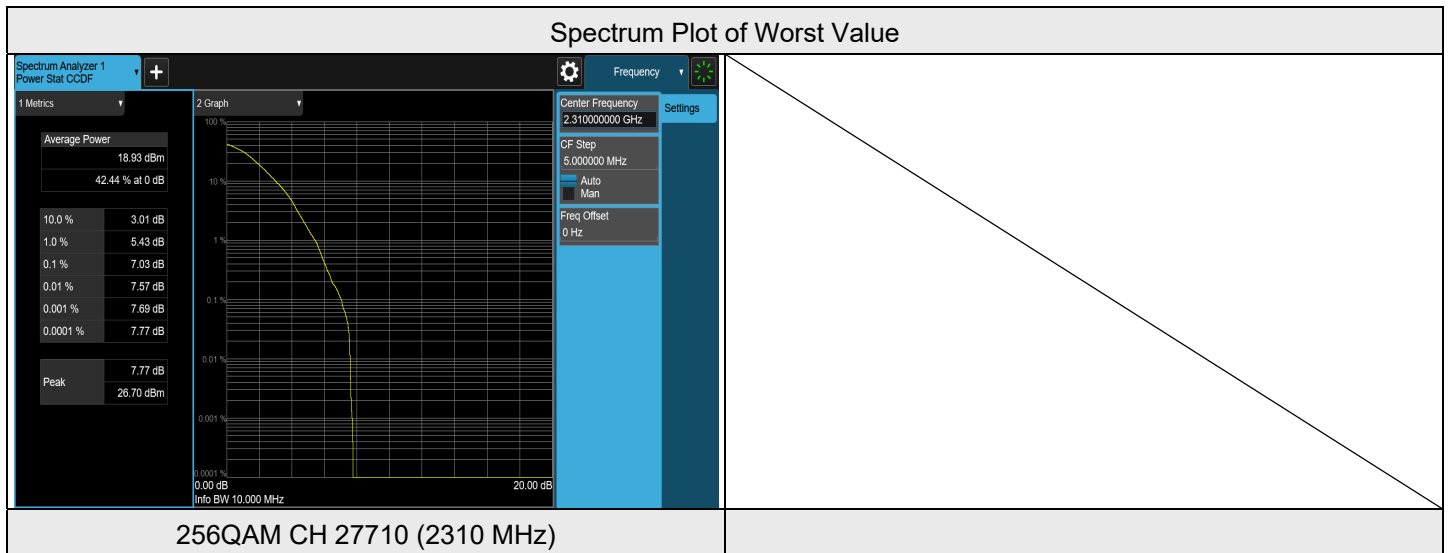

7.3.7 LTE Band 66

LTE Band 66, Channel Bandwidth: 1.4 MHz

Modulation	Channel	Frequency (MHz)	Measurement Value(dB)	Limit (dB)	Result
QPSK	131979	1710.7	4.34	13	PASS
QPSK	132322	1745	4.55	13	PASS
QPSK	132665	1779.3	4.19	13	PASS
16QAM	131979	1710.7	5.44	13	PASS
16QAM	132322	1745	5.60	13	PASS
16QAM	132665	1779.3	5.16	13	PASS
64QAM	131979	1710.7	5.64	13	PASS
64QAM	132322	1745	5.97	13	PASS
64QAM	132665	1779.3	5.48	13	PASS
256QAM	131979	1710.7	6.86	13	PASS
256QAM	132322	1745	6.95	13	PASS
256QAM	132665	1779.3	6.90	13	PASS

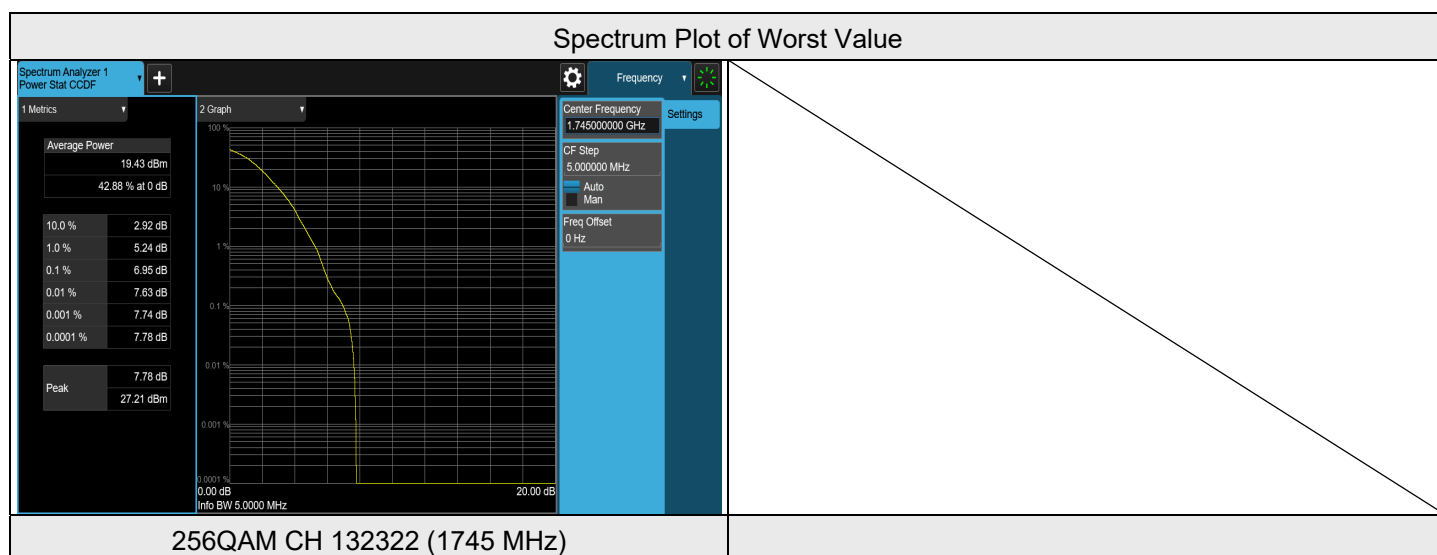

### LTE Band 66, Channel Bandwidth: 3 MHz

Modulation	Channel	Frequency (MHz)	Measurement Value(dB)	Limit (dB)	Result
QPSK	131987	1711.5	4.32	13	PASS
QPSK	132322	1745	4.37	13	PASS
QPSK	132657	1778.5	3.62	13	PASS
16QAM	131987	1711.5	4.79	13	PASS
16QAM	132322	1745	5.27	13	PASS
16QAM	132657	1778.5	4.50	13	PASS
64QAM	131987	1711.5	5.44	13	PASS
64QAM	132322	1745	5.95	13	PASS
64QAM	132657	1778.5	5.15	13	PASS
256QAM	131987	1711.5	5.74	13	PASS
256QAM	132322	1745	6.10	13	PASS
256QAM	132657	1778.5	6.00	13	PASS

Spectrum Plot of Worst Value

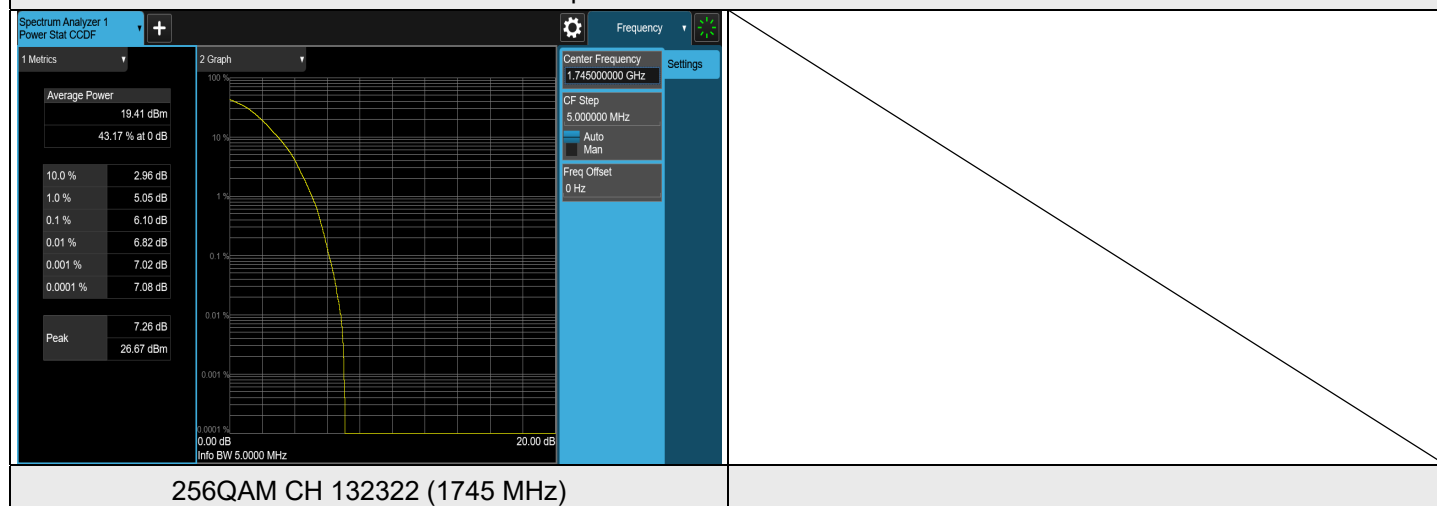

LTE Band 66, Channel Bandwidth: 5 MHz

Modulation	Channel	Frequency (MHz)	Measurement Value(dB)	Limit (dB)	Result
QPSK	131997	1712.5	4.34	13	PASS
QPSK	132322	1745	4.58	13	PASS
QPSK	132647	1777.5	4.04	13	PASS
16QAM	131997	1712.5	5.44	13	PASS
16QAM	132322	1745	5.57	13	PASS
16QAM	132647	1777.5	5.09	13	PASS
64QAM	131997	1712.5	5.69	13	PASS
64QAM	132322	1745	6.04	13	PASS
64QAM	132647	1777.5	5.35	13	PASS
256QAM	131997	1712.5	6.87	13	PASS
256QAM	132322	1745	7.01	13	PASS
256QAM	132647	1777.5	6.72	13	PASS

Spectrum Plot of Worst Value

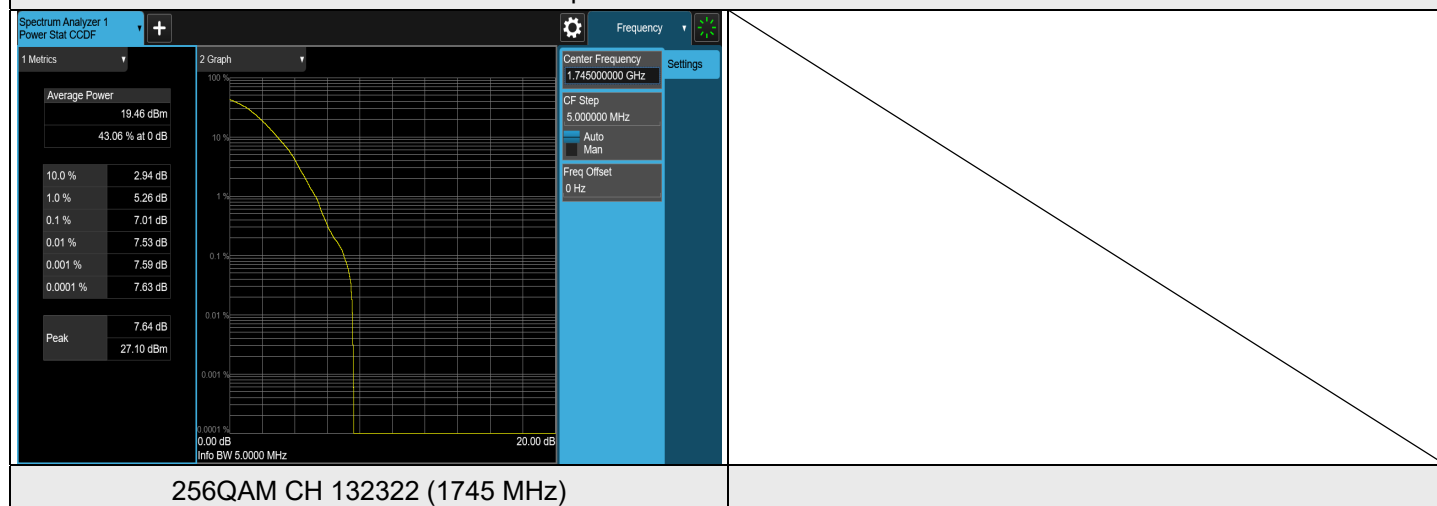

LTE Band 66, Channel Bandwidth: 10 MHz

Modulation	Channel	Frequency (MHz)	Measurement Value(dB)	Limit (dB)	Result
QPSK	132022	1715	4.33	13	PASS
QPSK	132322	1745	4.57	13	PASS
QPSK	132622	1775	4.29	13	PASS
16QAM	132022	1715	5.44	13	PASS
16QAM	132322	1745	5.55	13	PASS
16QAM	132622	1775	5.30	13	PASS
64QAM	132022	1715	5.64	13	PASS
64QAM	132322	1745	6.19	13	PASS
64QAM	132622	1775	5.72	13	PASS
256QAM	132022	1715	6.64	13	PASS
256QAM	132322	1745	6.92	13	PASS
256QAM	132622	1775	6.85	13	PASS

Spectrum Plot of Worst Value

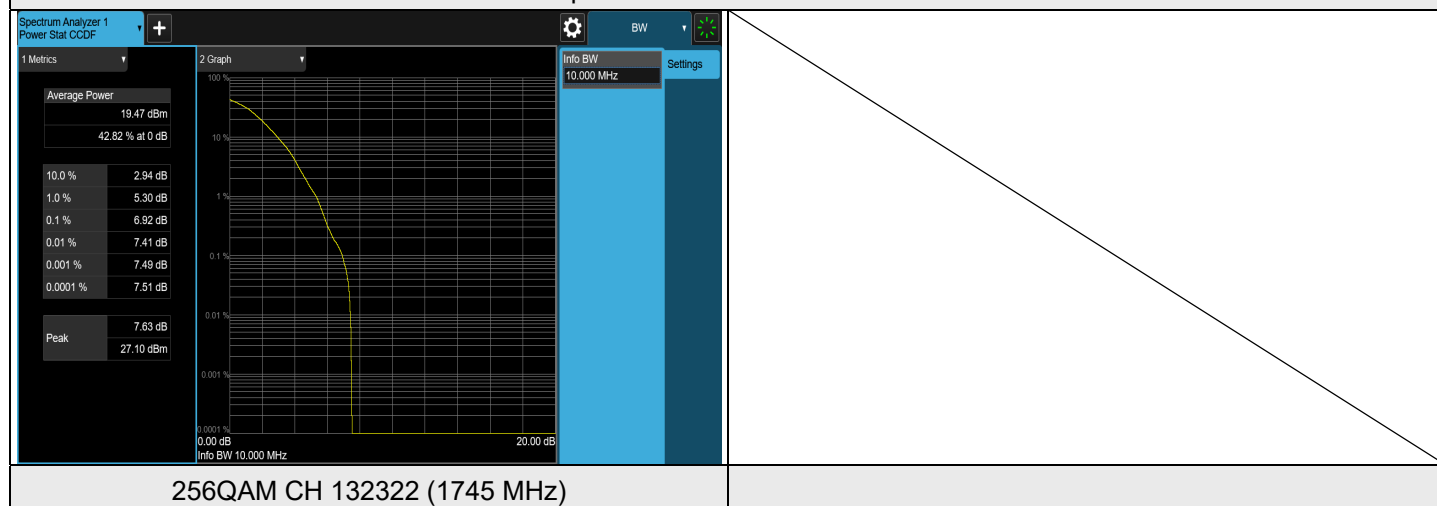

### LTE Band 66, Channel Bandwidth: 15 MHz

Modulation	Channel	Frequency (MHz)	Measurement Value(dB)	Limit (dB)	Result
QPSK	132047	1717.5	4.21	13	PASS
QPSK	132322	1745	4.55	13	PASS
QPSK	132597	1772.5	4.28	13	PASS
16QAM	132047	1717.5	5.03	13	PASS
16QAM	132322	1745	5.32	13	PASS
16QAM	132597	1772.5	5.40	13	PASS
64QAM	132047	1717.5	5.71	13	PASS
64QAM	132322	1745	5.93	13	PASS
64QAM	132597	1772.5	5.89	13	PASS
256QAM	132047	1717.5	7.32	13	PASS
256QAM	132322	1745	6.03	13	PASS
256QAM	132597	1772.5	7.25	13	PASS

Spectrum Plot of Worst Value

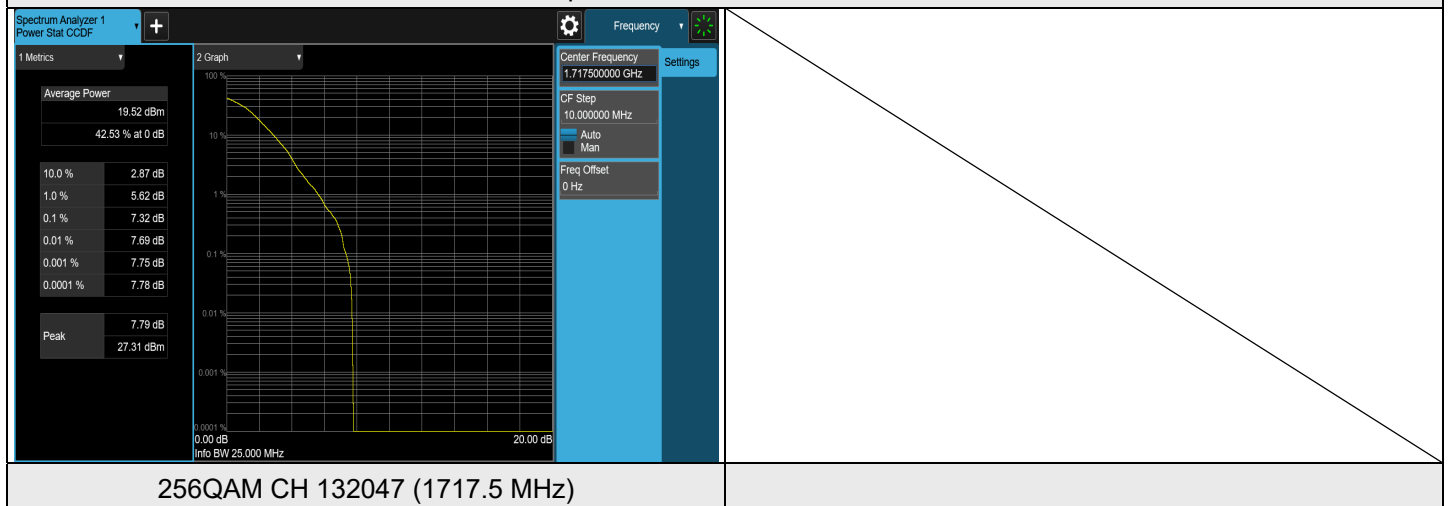

LTE Band 66, Channel Bandwidth: 20 MHz

Modulation	Channel	Frequency (MHz)	Measurement Value(dB)	Limit (dB)	Result
QPSK	132072	1720	3.97	13	PASS
QPSK	132322	1745	4.34	13	PASS
QPSK	132572	1770	4.38	13	PASS
16QAM	132072	1720	5.71	13	PASS
16QAM	132322	1745	5.26	13	PASS
16QAM	132572	1770	5.14	13	PASS
64QAM	132072	1720	5.67	13	PASS
64QAM	132322	1745	5.96	13	PASS
64QAM	132572	1770	5.71	13	PASS
256QAM	132072	1720	7.00	13	PASS
256QAM	132322	1745	6.47	13	PASS
256QAM	132572	1770	7.24	13	PASS

Spectrum Plot of Worst Value

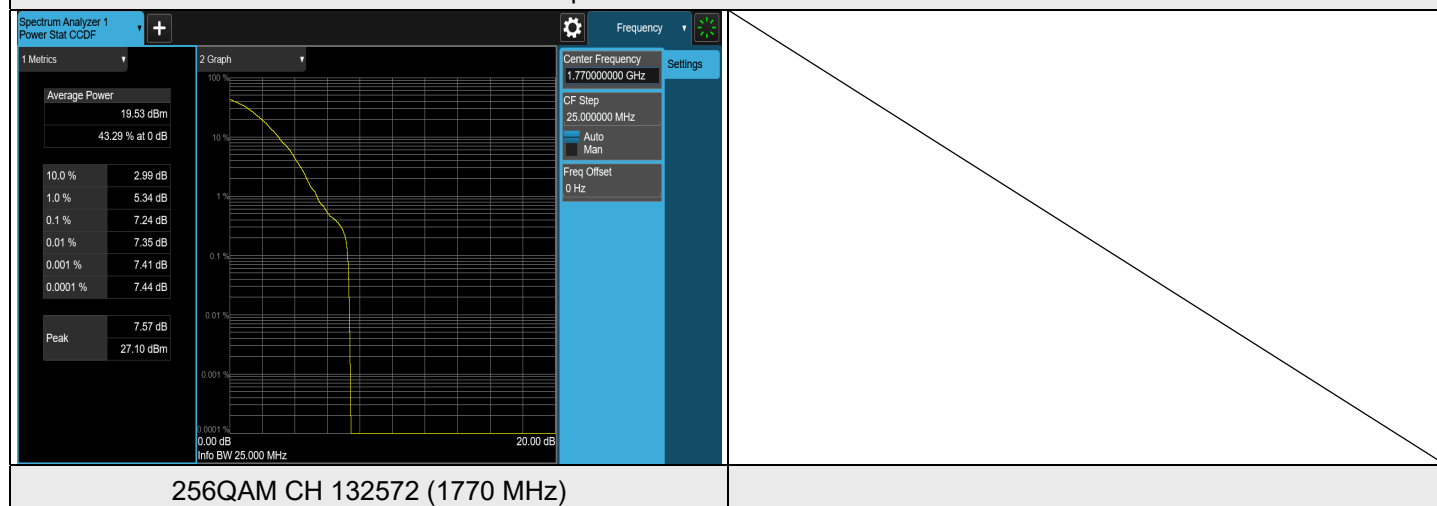



## 7.4 Bandwidth

Input Power:	120 Vac, 60 Hz	Environmental Conditions:	22°C, 74% RH	Tested By:	Willy Cheng
--------------	----------------	---------------------------	--------------	------------	-------------

### 7.4.1 LTE Band 2

#### LTE Band 2, Channel Bandwidth: 1.4 MHz

Modulation	Channel	Frequency (MHz)	Occupied Bandwidth (MHz)	26 dB Bandwidth (MHz)
QPSK	18607	1850.7	1.0884	1.257
QPSK	18900	1880	1.0935	1.267
QPSK	19193	1909.3	1.0930	1.274
16QAM	18607	1850.7	1.0890	1.250
16QAM	18900	1880	1.0902	1.250
16QAM	19193	1909.3	1.0898	1.254
64QAM	18607	1850.7	1.0880	1.257
64QAM	18900	1880	1.0893	1.256
64QAM	19193	1909.3	1.0894	1.261
256QAM	18607	1850.7	1.0845	1.235
256QAM	18900	1880	1.0848	1.233
256QAM	19193	1909.3	1.0863	1.237

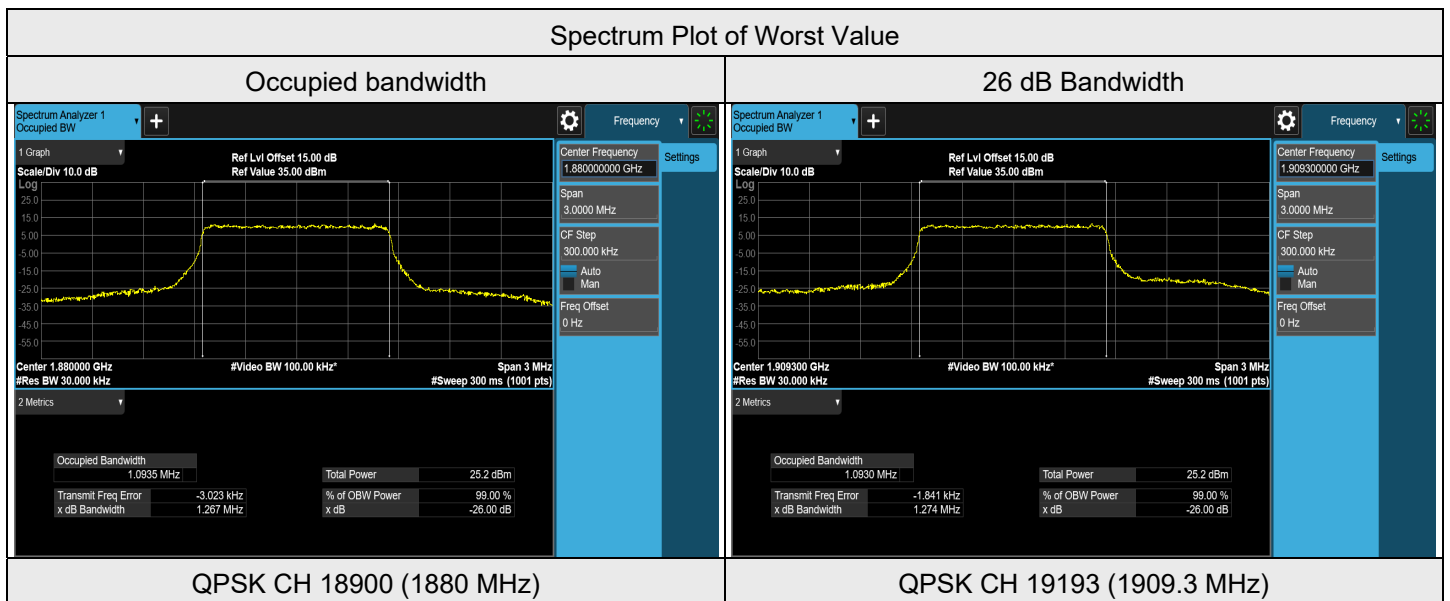

LTE Band 2, Channel Bandwidth: 3 MHz

Modulation	Channel	Frequency (MHz)	Occupied Bandwidth (MHz)	26 dB Bandwidth (MHz)
QPSK	18615	1851.5	2.7007	2.873
QPSK	18900	1880	2.7000	2.879
QPSK	19185	1908.5	2.7019	2.886
16QAM	18615	1851.5	2.6993	2.885
16QAM	18900	1880	2.6997	2.891
16QAM	19185	1908.5	2.7012	2.897
64QAM	18615	1851.5	2.6963	2.873
64QAM	18900	1880	2.6986	2.876
64QAM	19185	1908.5	2.6997	2.888
256QAM	18615	1851.5	2.6981	2.884
256QAM	18900	1880	2.6986	2.878
256QAM	19185	1908.5	2.6990	2.876

Spectrum Plot of Worst Value

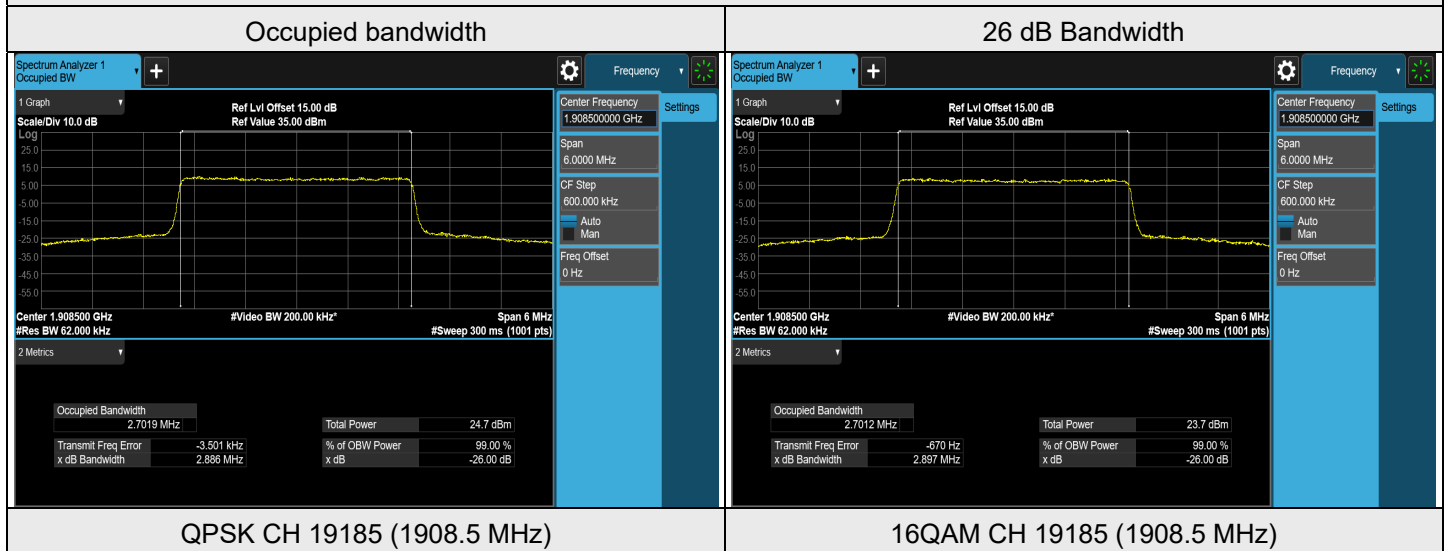

LTE Band 2, Channel Bandwidth: 5 MHz

Modulation	Channel	Frequency (MHz)	Occupied Bandwidth (MHz)	26 dB Bandwidth (MHz)
QPSK	18625	1852.5	4.4917	4.788
QPSK	18900	1880	4.4935	4.792
QPSK	19175	1907.5	4.4960	4.795
16QAM	18625	1852.5	4.4867	4.778
16QAM	18900	1880	4.4903	4.781
16QAM	19175	1907.5	4.4944	4.791
64QAM	18625	1852.5	4.4951	4.817
64QAM	18900	1880	4.4934	4.792
64QAM	19175	1907.5	4.4986	4.819
256QAM	18625	1852.5	4.4849	4.779
256QAM	18900	1880	4.4847	4.769
256QAM	19175	1907.5	4.4885	4.772

Spectrum Plot of Worst Value

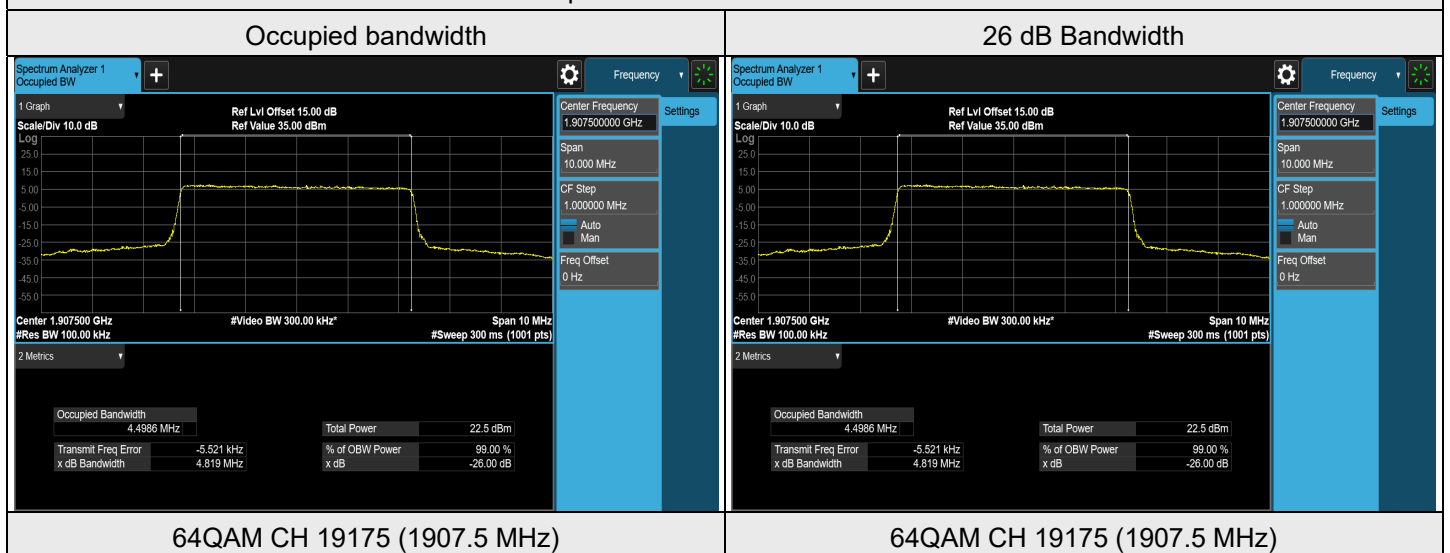

LTE Band 2, Channel Bandwidth: 10 MHz

Modulation	Channel	Frequency (MHz)	Occupied Bandwidth (MHz)	26 dB Bandwidth (MHz)
QPSK	18650	1855	8.9788	9.507
QPSK	18900	1880	8.9752	9.498
QPSK	19150	1905	8.9713	9.491
16QAM	18650	1855	8.9772	9.506
16QAM	18900	1880	8.9720	9.499
16QAM	19150	1905	8.9678	9.485
64QAM	18650	1855	8.9823	9.518
64QAM	18900	1880	8.9788	9.509
64QAM	19150	1905	8.9709	9.504
256QAM	18650	1855	8.9698	9.495
256QAM	18900	1880	8.9648	9.491
256QAM	19150	1905	8.9706	9.504

Spectrum Plot of Worst Value

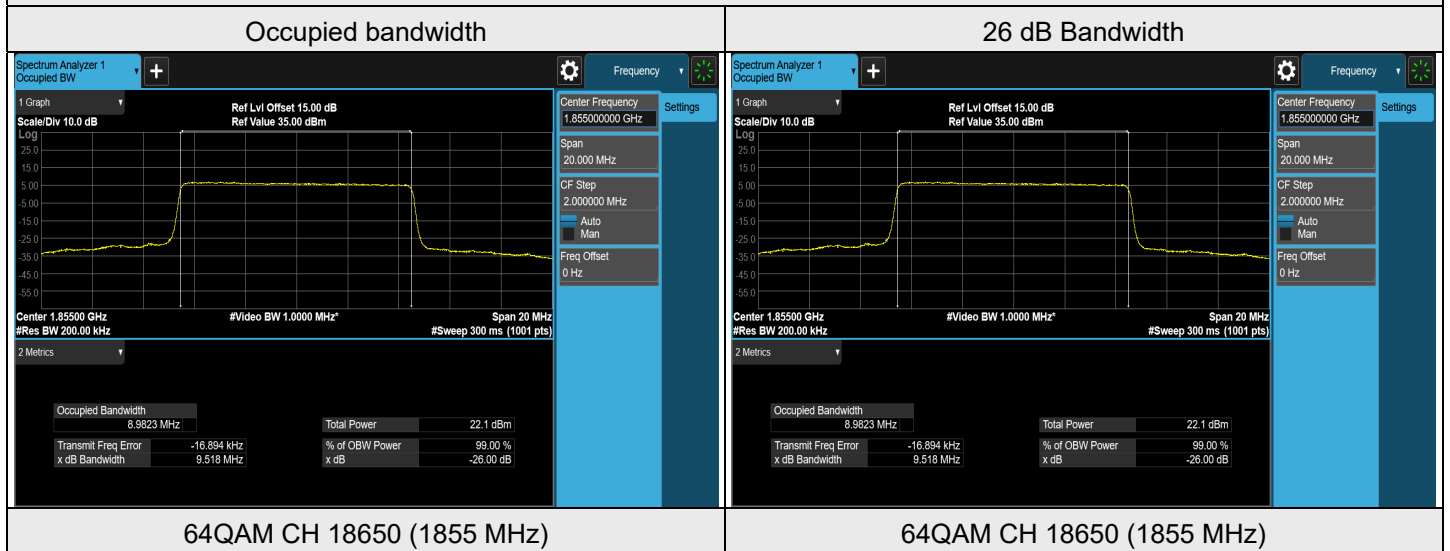

### LTE Band 2, Channel Bandwidth: 15 MHz

Modulation	Channel	Frequency (MHz)	Occupied Bandwidth (MHz)	26 dB Bandwidth (MHz)
QPSK	18675	1857.5	13.4984	14.243
QPSK	18900	1880	13.4625	14.230
QPSK	19125	1902.5	13.4265	14.211
16QAM	18675	1857.5	13.4797	14.253
16QAM	18900	1880	13.4531	14.229
16QAM	19125	1902.5	13.4291	14.205
64QAM	18675	1857.5	13.4710	14.234
64QAM	18900	1880	13.4423	14.228
64QAM	19125	1902.5	13.4197	14.220
256QAM	18675	1857.5	13.4752	14.245
256QAM	18900	1880	13.4385	14.214
256QAM	19125	1902.5	13.4114	14.199

### Spectrum Plot of Worst Value

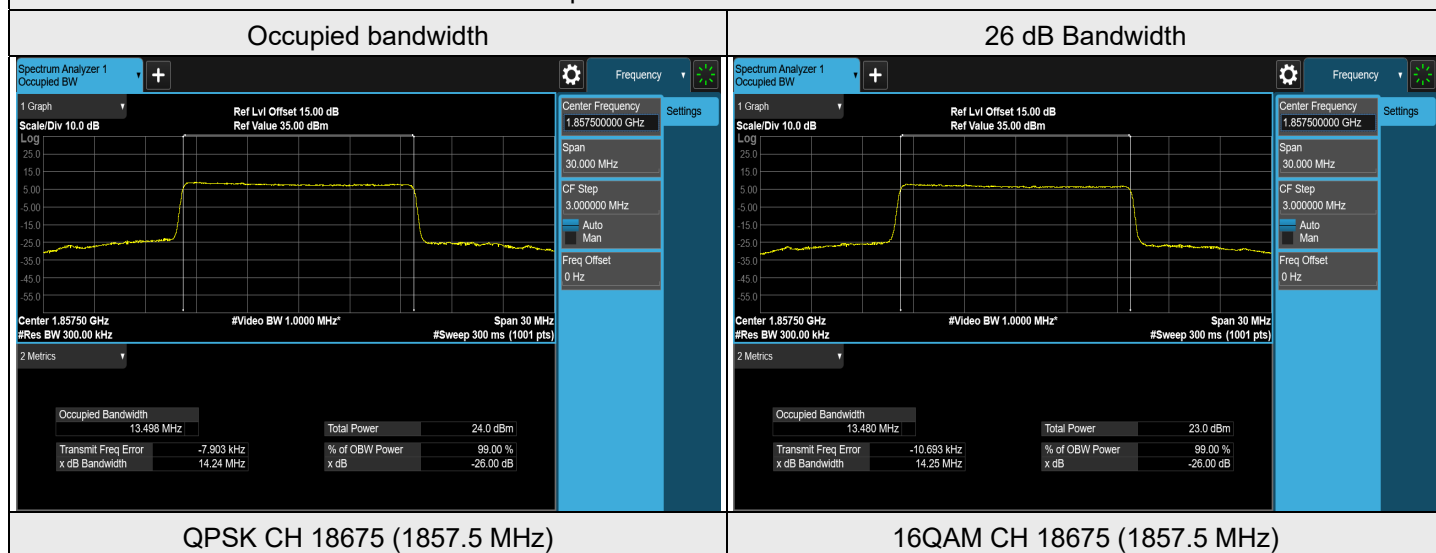

LTE Band 2, Channel Bandwidth: 20 MHz

Modulation	Channel	Frequency (MHz)	Occupied Bandwidth (MHz)	26 dB Bandwidth (MHz)
QPSK	18700	1860	18.0127	19.042
QPSK	18900	1880	17.9491	19.011
QPSK	19100	1900	17.9014	18.992
16QAM	18700	1860	18.0195	19.043
16QAM	18900	1880	17.9513	19.023
16QAM	19100	1900	17.9004	18.998
64QAM	18700	1860	18.0089	19.042
64QAM	18900	1880	17.9414	19.006
64QAM	19100	1900	17.8911	18.986
256QAM	18700	1860	17.9995	19.022
256QAM	18900	1880	17.9378	18.998
256QAM	19100	1900	17.8797	18.974

Spectrum Plot of Worst Value

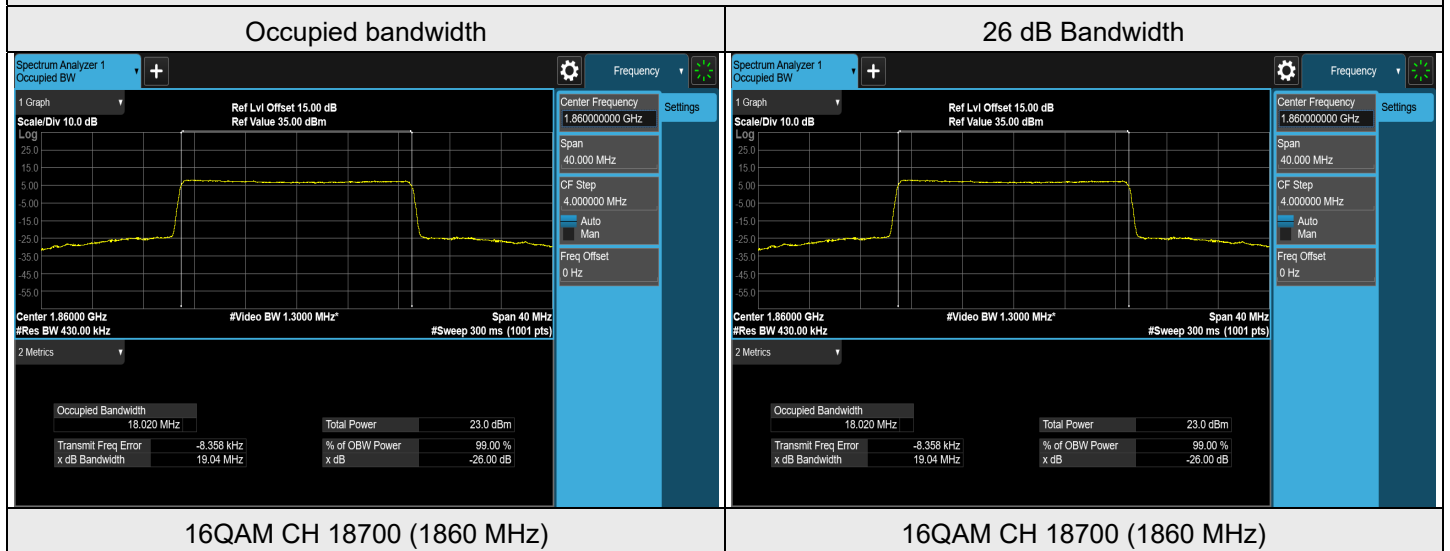

## 7.4.2 LTE Band 4

### LTE Band 4, Channel Bandwidth: 1.4 MHz

Modulation	Channel	Frequency (MHz)	Occupied Bandwidth (MHz)	26 dB Bandwidth (MHz)
QPSK	19957	1710.7	1.0859	1.239
QPSK	20175	1732.5	1.0913	1.256
QPSK	20393	1754.3	1.0932	1.277
16QAM	19957	1710.7	1.0901	1.252
16QAM	20175	1732.5	1.0898	1.254
16QAM	20393	1754.3	1.0919	1.260
64QAM	19957	1710.7	1.0898	1.260
64QAM	20175	1732.5	1.0882	1.262
64QAM	20393	1754.3	1.0891	1.260
256QAM	19957	1710.7	1.0852	1.242
256QAM	20175	1732.5	1.0859	1.230
256QAM	20393	1754.3	1.0851	1.239

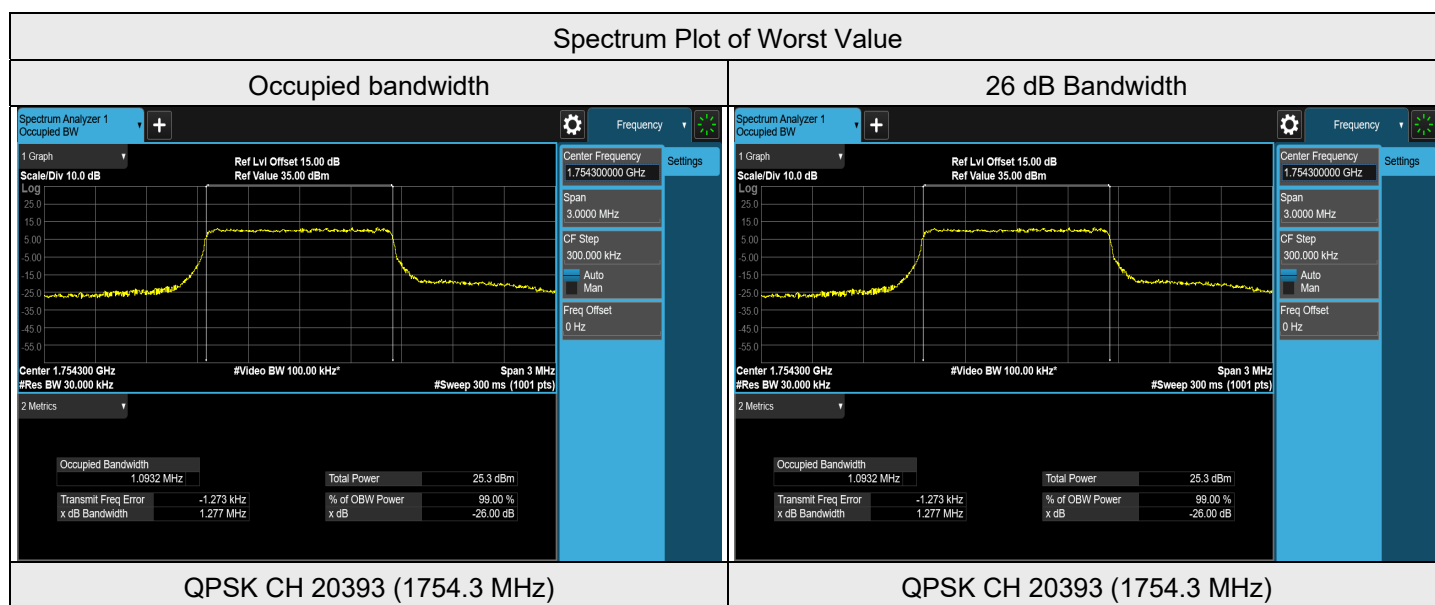

### LTE Band 4, Channel Bandwidth: 3 MHz

Modulation	Channel	Frequency (MHz)	Occupied Bandwidth (MHz)	26 dB Bandwidth (MHz)
QPSK	19965	1711.5	2.7033	2.889
QPSK	20175	1732.5	2.7004	2.881
QPSK	20385	1753.5	2.7000	2.887
16QAM	19965	1711.5	2.7011	2.897
16QAM	20175	1732.5	2.6976	2.888
16QAM	20385	1753.5	2.6988	2.895
64QAM	19965	1711.5	2.6988	2.875
64QAM	20175	1732.5	2.6965	2.872
64QAM	20385	1753.5	2.7001	2.875
256QAM	19965	1711.5	2.6989	2.876
256QAM	20175	1732.5	2.6977	2.876
256QAM	20385	1753.5	2.6998	2.876

### Spectrum Plot of Worst Value

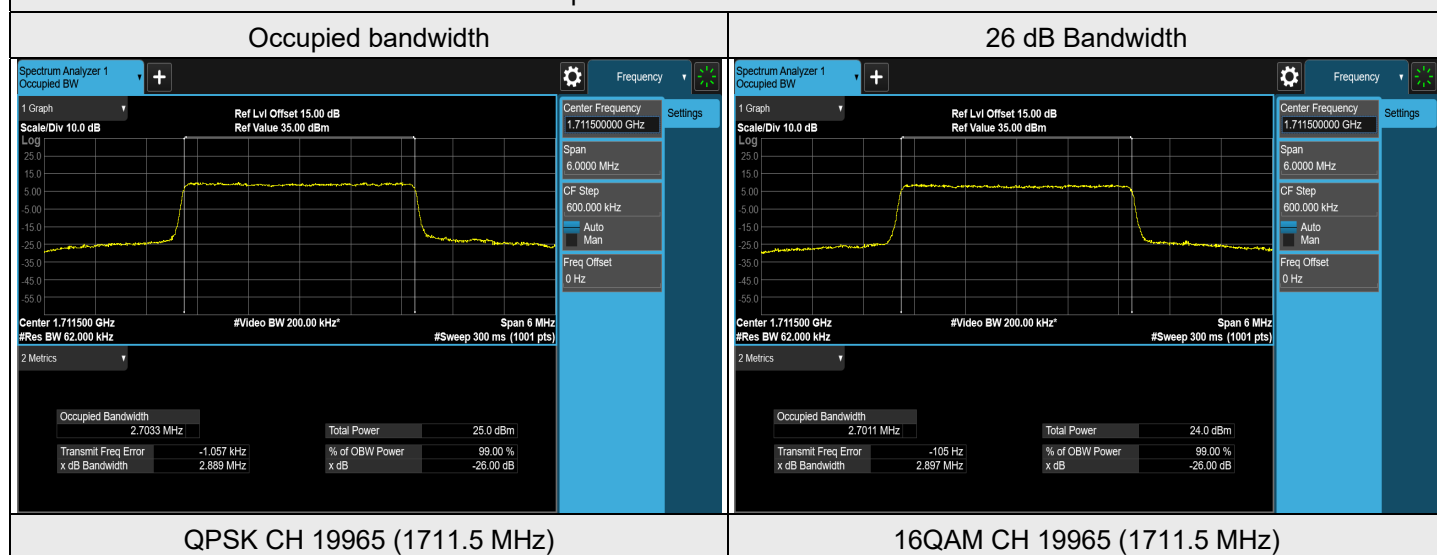



LTE Band 4, Channel Bandwidth: 5 MHz

Modulation	Channel	Frequency (MHz)	Occupied Bandwidth (MHz)	26 dB Bandwidth (MHz)
QPSK	19975	1712.5	4.4966	4.808
QPSK	20175	1732.5	4.4937	4.794
QPSK	20375	1752.5	4.5005	4.815
16QAM	19975	1712.5	4.4943	4.781
16QAM	20175	1732.5	4.4882	4.792
16QAM	20375	1752.5	4.4925	4.785
64QAM	19975	1712.5	4.4979	4.805
64QAM	20175	1732.5	4.4950	4.808
64QAM	20375	1752.5	4.4963	4.799
256QAM	19975	1712.5	4.4865	4.782
256QAM	20175	1732.5	4.4812	4.775
256QAM	20375	1752.5	4.4880	4.785

Spectrum Plot of Worst Value

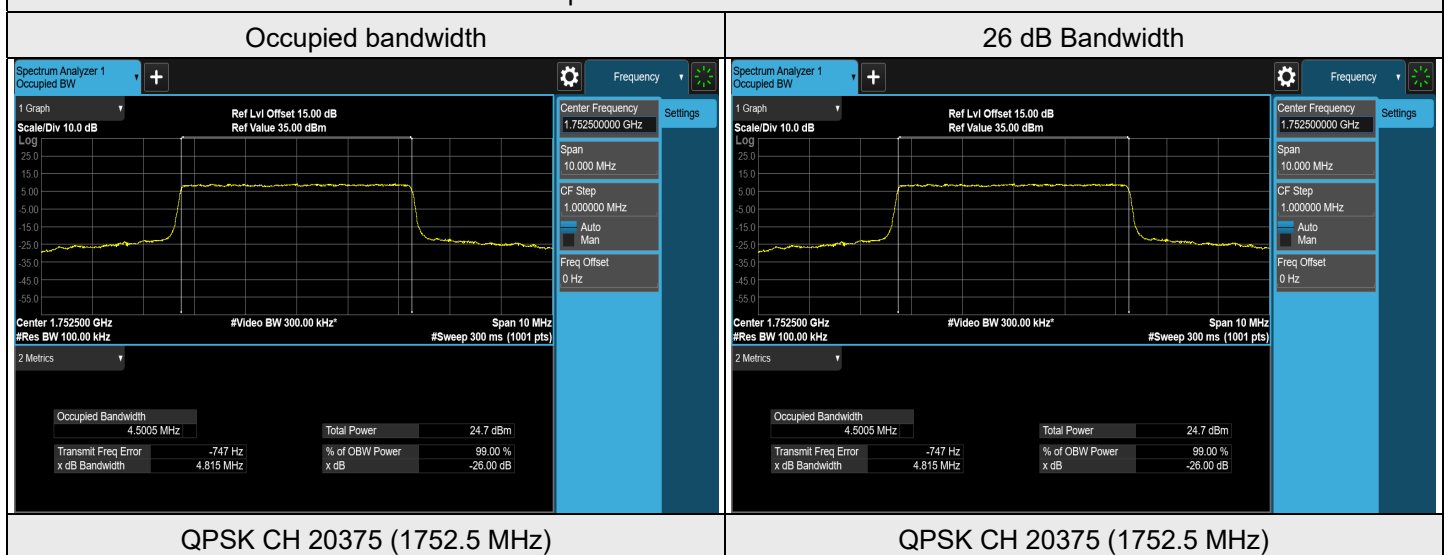

LTE Band 4, Channel Bandwidth: 10 MHz

Modulation	Channel	Frequency (MHz)	Occupied Bandwidth (MHz)	26 dB Bandwidth (MHz)
QPSK	20000	1715	8.9872	9.543
QPSK	20175	1732.5	8.9682	9.497
QPSK	20350	1750	8.9923	9.523
16QAM	20000	1715	8.9837	9.520
16QAM	20175	1732.5	8.9632	9.504
16QAM	20350	1750	8.9897	9.520
64QAM	20000	1715	8.9831	9.516
64QAM	20175	1732.5	8.9675	9.506
64QAM	20350	1750	8.9856	9.528
256QAM	20000	1715	8.9786	9.511
256QAM	20175	1732.5	8.9647	9.502
256QAM	20350	1750	8.9796	9.510

Spectrum Plot of Worst Value

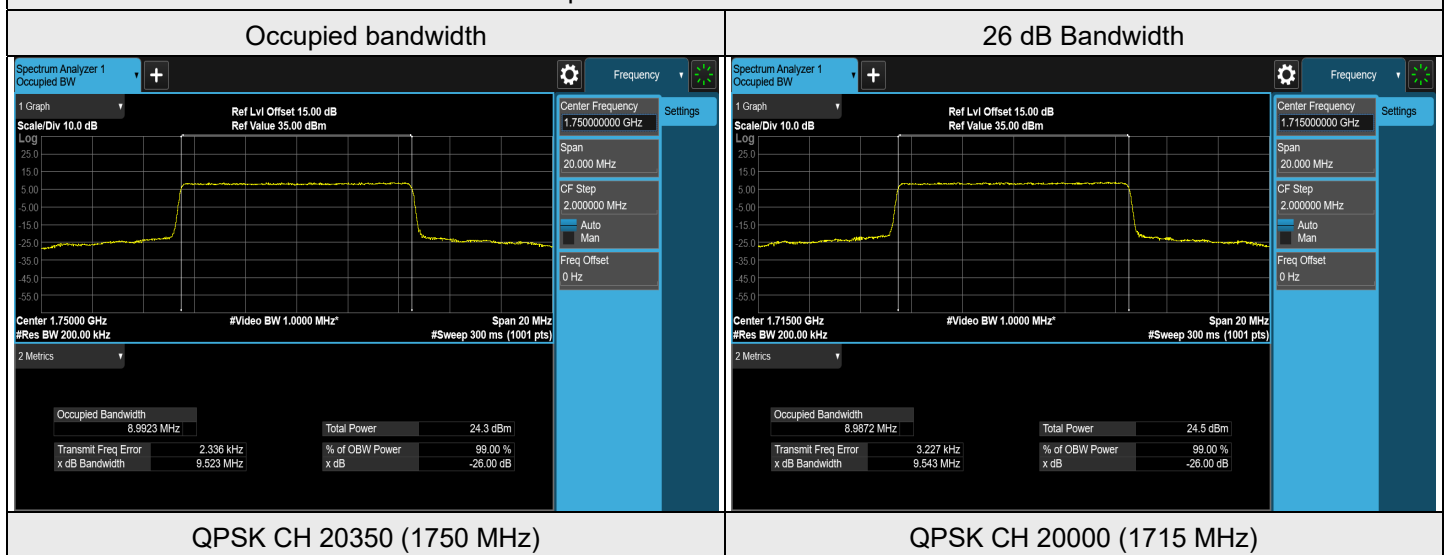

### LTE Band 4, Channel Bandwidth: 15 MHz

Modulation	Channel	Frequency (MHz)	Occupied Bandwidth (MHz)	26 dB Bandwidth (MHz)
QPSK	20025	1717.5	13.4897	14.246
QPSK	20175	1732.5	13.4434	14.215
QPSK	20325	1747.5	13.4960	14.261
16QAM	20025	1717.5	13.4754	14.257
16QAM	20175	1732.5	13.4398	14.214
16QAM	20325	1747.5	13.4802	14.259
64QAM	20025	1717.5	13.4647	14.241
64QAM	20175	1732.5	13.4321	14.221
64QAM	20325	1747.5	13.4676	14.250
256QAM	20025	1717.5	13.4655	14.240
256QAM	20175	1732.5	13.4359	14.213
256QAM	20325	1747.5	13.4750	14.246

### Spectrum Plot of Worst Value

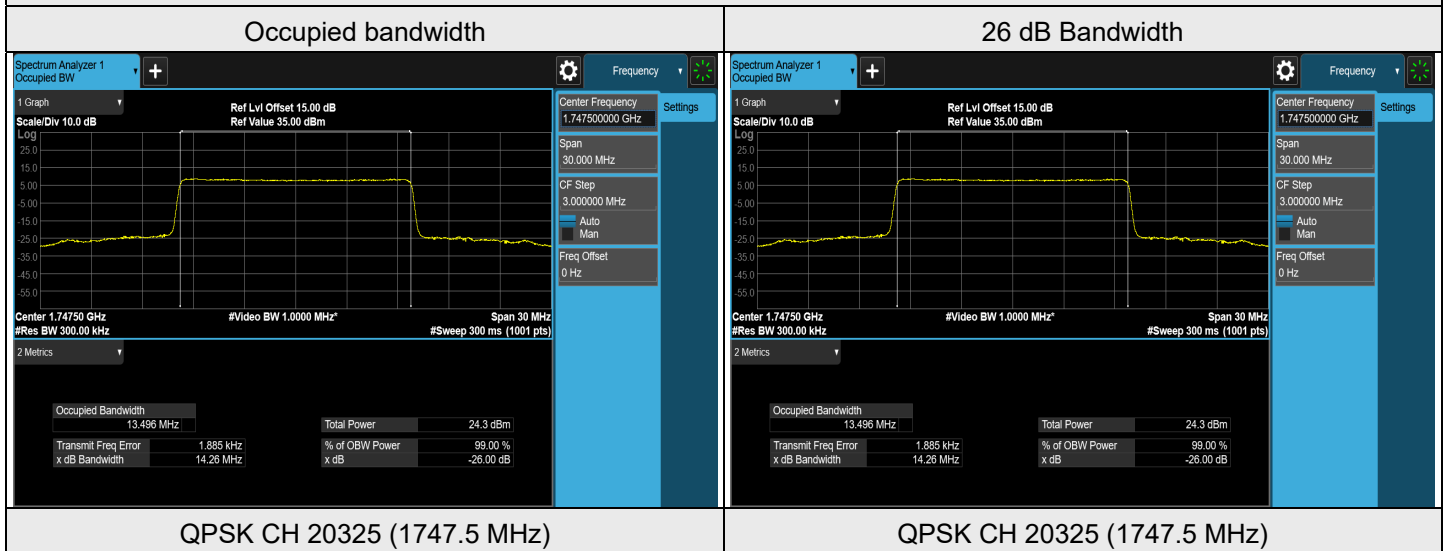

LTE Band 4, Channel Bandwidth: 20 MHz

Modulation	Channel	Frequency (MHz)	Occupied Bandwidth (MHz)	26 dB Bandwidth (MHz)
QPSK	20050	1720	17.9795	19.034
QPSK	20175	1732.5	17.9086	19.008
QPSK	20300	1745	17.9895	19.038
16QAM	20050	1720	17.9838	19.016
16QAM	20175	1732.5	17.9264	19.000
16QAM	20300	1745	17.9943	19.023
64QAM	20050	1720	17.9712	19.013
64QAM	20175	1732.5	17.9154	19.008
64QAM	20300	1745	17.9885	19.026
256QAM	20050	1720	17.9655	18.996
256QAM	20175	1732.5	17.9227	19.003
256QAM	20300	1745	17.9920	18.920

Spectrum Plot of Worst Value

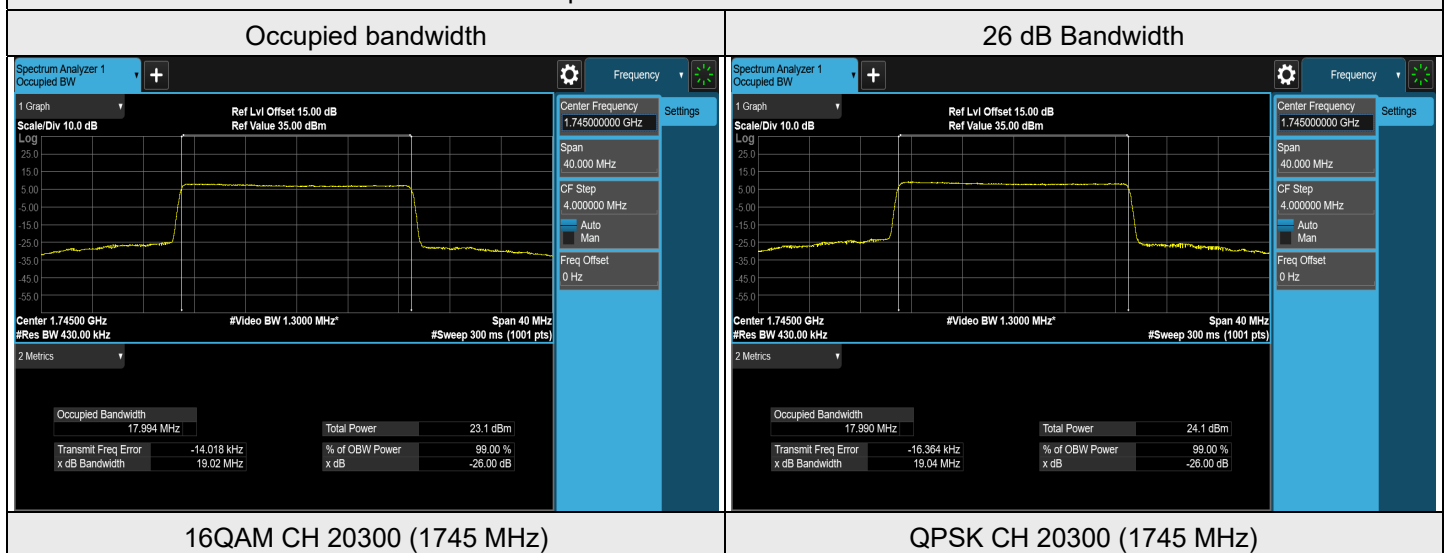

### 7.4.3 LTE Band 5

#### LTE Band 5, Channel Bandwidth: 1.4 MHz

Modulation	Channel	Frequency (MHz)	Occupied Bandwidth (MHz)	26 dB Bandwidth (MHz)
QPSK	20407	824.7	1.0879	1.251
QPSK	20525	836.5	1.0917	1.268
QPSK	20643	848.3	1.0910	1.237
16QAM	20407	824.7	1.0873	1.244
16QAM	20525	836.5	1.0897	1.255
16QAM	20643	848.3	1.0899	1.248
64QAM	20407	824.7	1.0887	1.254
64QAM	20525	836.5	1.0888	1.269
64QAM	20643	848.3	1.0883	1.266
256QAM	20407	824.7	1.0858	1.235
256QAM	20525	836.5	1.0857	1.239
256QAM	20643	848.3	1.0858	1.254

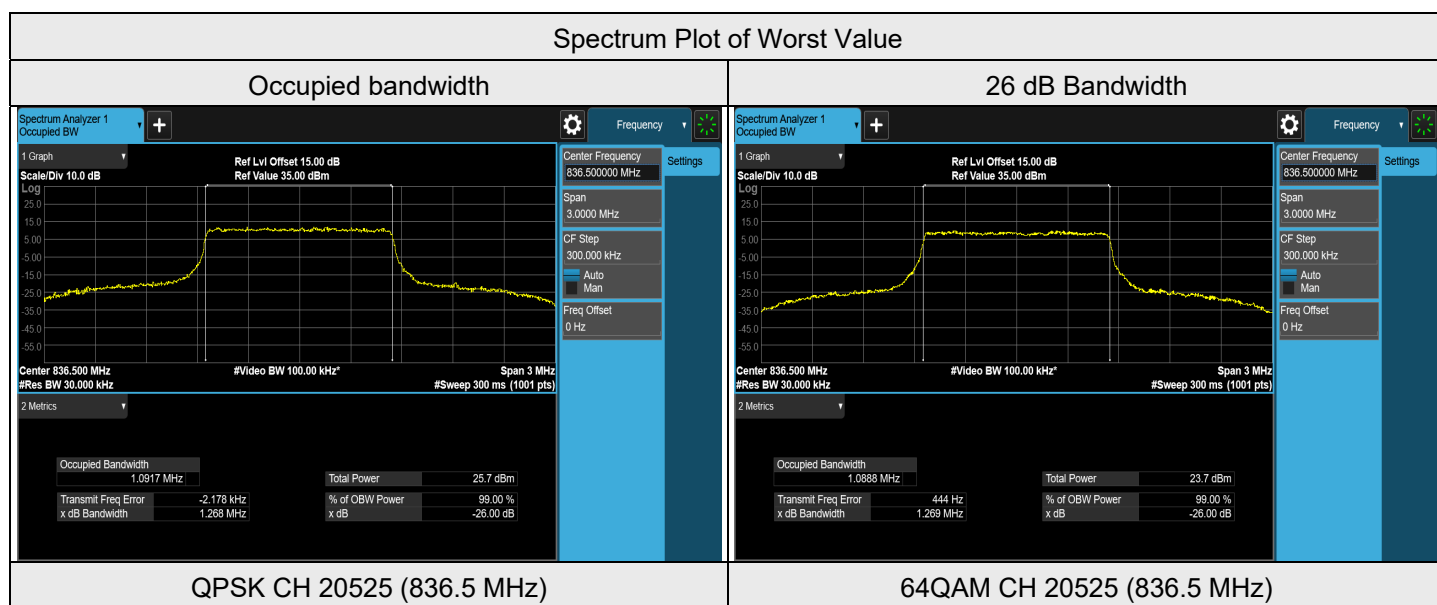

### LTE Band 5, Channel Bandwidth: 3 MHz

Modulation	Channel	Frequency (MHz)	Occupied Bandwidth (MHz)	26 dB Bandwidth (MHz)
QPSK	20415	825.5	2.7023	2.880
QPSK	20525	836.5	2.7003	2.885
QPSK	20635	847.5	2.7015	2.883
16QAM	20415	825.5	2.6987	2.888
16QAM	20525	836.5	2.7011	2.896
16QAM	20635	847.5	2.7028	2.891
64QAM	20415	825.5	2.6975	2.873
64QAM	20525	836.5	2.6989	2.873
64QAM	20635	847.5	2.7009	2.868
256QAM	20415	825.5	2.6993	2.882
256QAM	20525	836.5	2.6978	2.879
256QAM	20635	847.5	2.7010	2.875

### Spectrum Plot of Worst Value

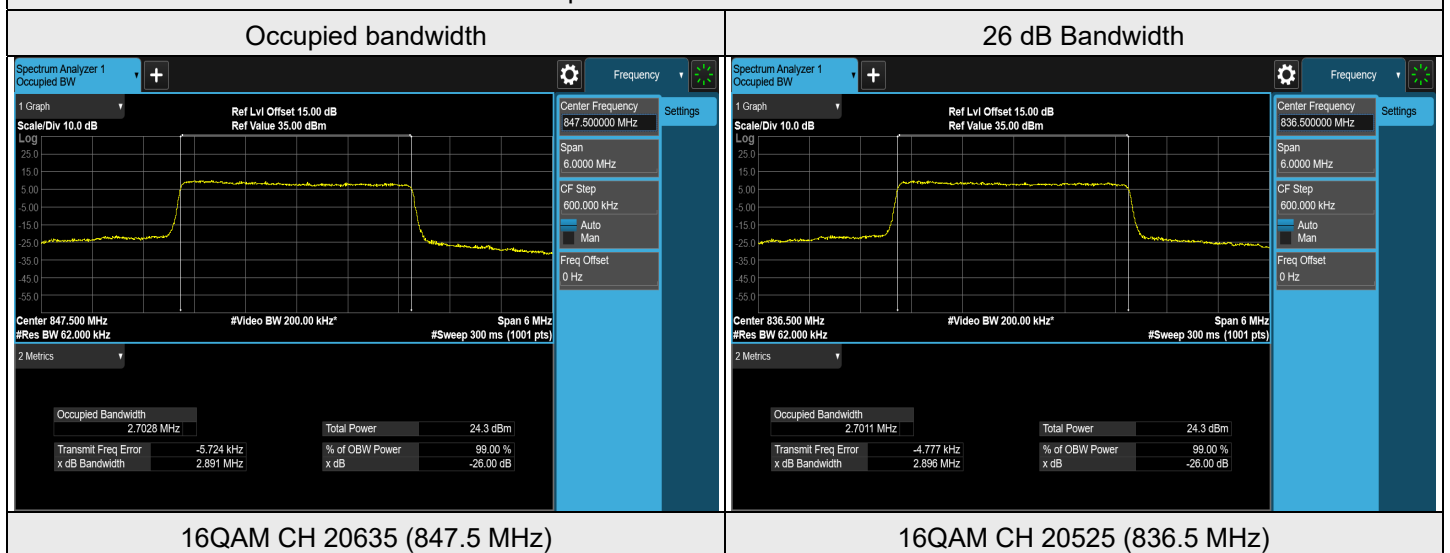

LTE Band 5, Channel Bandwidth: 5 MHz

Modulation	Channel	Frequency (MHz)	Occupied Bandwidth (MHz)	26 dB Bandwidth (MHz)
QPSK	20425	826.5	4.4974	4.797
QPSK	20525	836.5	4.4971	4.828
QPSK	20625	846.5	4.4940	4.813
16QAM	20425	826.5	4.4907	4.772
16QAM	20525	836.5	4.4910	4.792
16QAM	20625	846.5	4.4903	4.785
64QAM	20425	826.5	4.4939	4.786
64QAM	20525	836.5	4.4976	4.827
64QAM	20625	846.5	4.4896	4.790
256QAM	20425	826.5	4.4864	4.788
256QAM	20525	836.5	4.4850	4.764
256QAM	20625	846.5	4.4784	4.766

Spectrum Plot of Worst Value

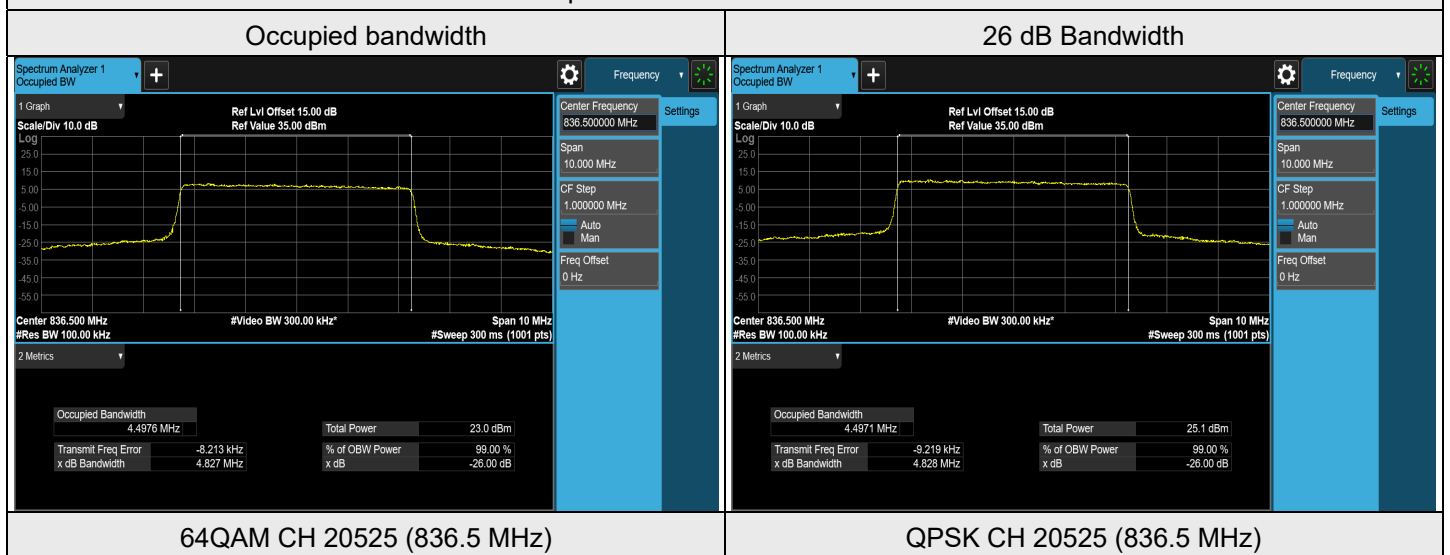

### LTE Band 5, Channel Bandwidth: 10 MHz

Modulation	Channel	Frequency (MHz)	Occupied Bandwidth (MHz)	26 dB Bandwidth (MHz)
QPSK	20450	829	8.9677	9.500
QPSK	20525	836.5	8.9940	9.539
QPSK	20600	844	8.9332	9.479
16QAM	20450	829	8.9683	9.492
16QAM	20525	836.5	8.9892	9.515
16QAM	20600	844	8.9330	9.478
64QAM	20450	829	8.9670	9.500
64QAM	20525	836.5	8.9872	9.536
64QAM	20600	844	8.9332	9.483
256QAM	20450	829	8.9610	9.485
256QAM	20525	836.5	8.9763	9.495
256QAM	20600	844	8.9248	9.471

### Spectrum Plot of Worst Value

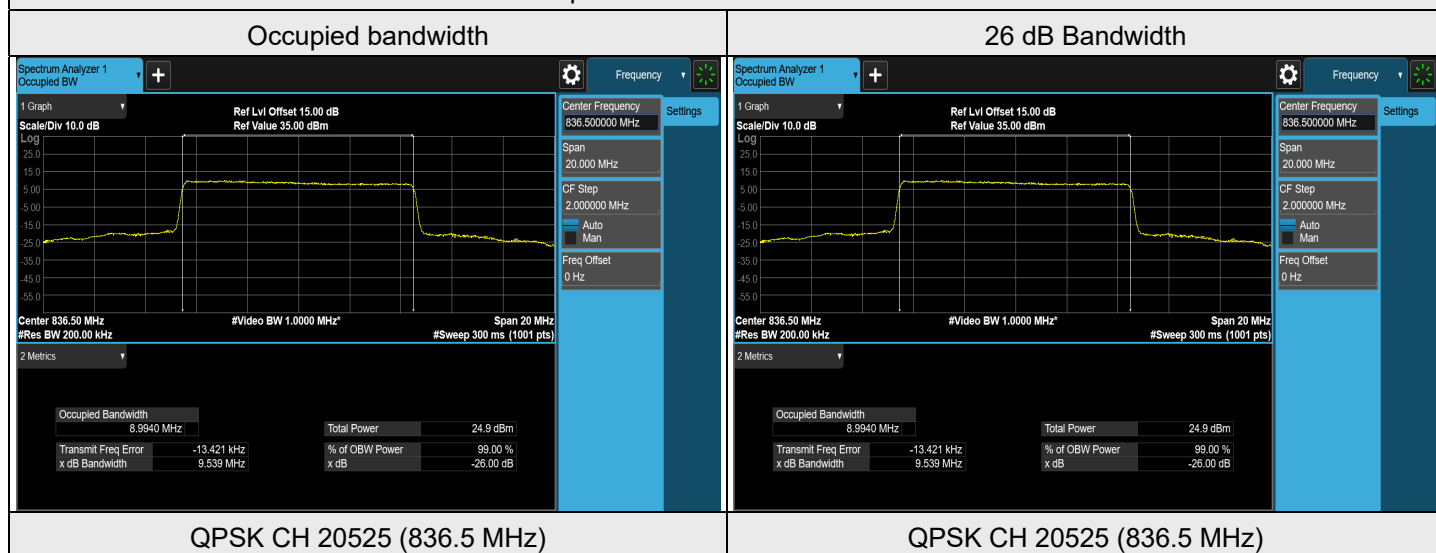



### 7.4.4 LTE Band 12

#### LTE Band 12, Channel Bandwidth: 1.4 MHz

Modulation	Channel	Frequency (MHz)	Occupied Bandwidth (MHz)	26 dB Bandwidth (MHz)
QPSK	23017	699.7	1.0881	1.254
QPSK	23095	707.5	1.0918	1.247
QPSK	23173	715.3	1.0923	1.270
16QAM	23017	699.7	1.0892	1.259
16QAM	23095	707.5	1.0890	1.259
16QAM	23173	715.3	1.0899	1.248
64QAM	23017	699.7	1.0878	1.249
64QAM	23095	707.5	1.0899	1.267
64QAM	23173	715.3	1.0892	1.262
256QAM	23017	699.7	1.0853	1.237
256QAM	23095	707.5	1.0866	1.238
256QAM	23173	715.3	1.0855	1.237

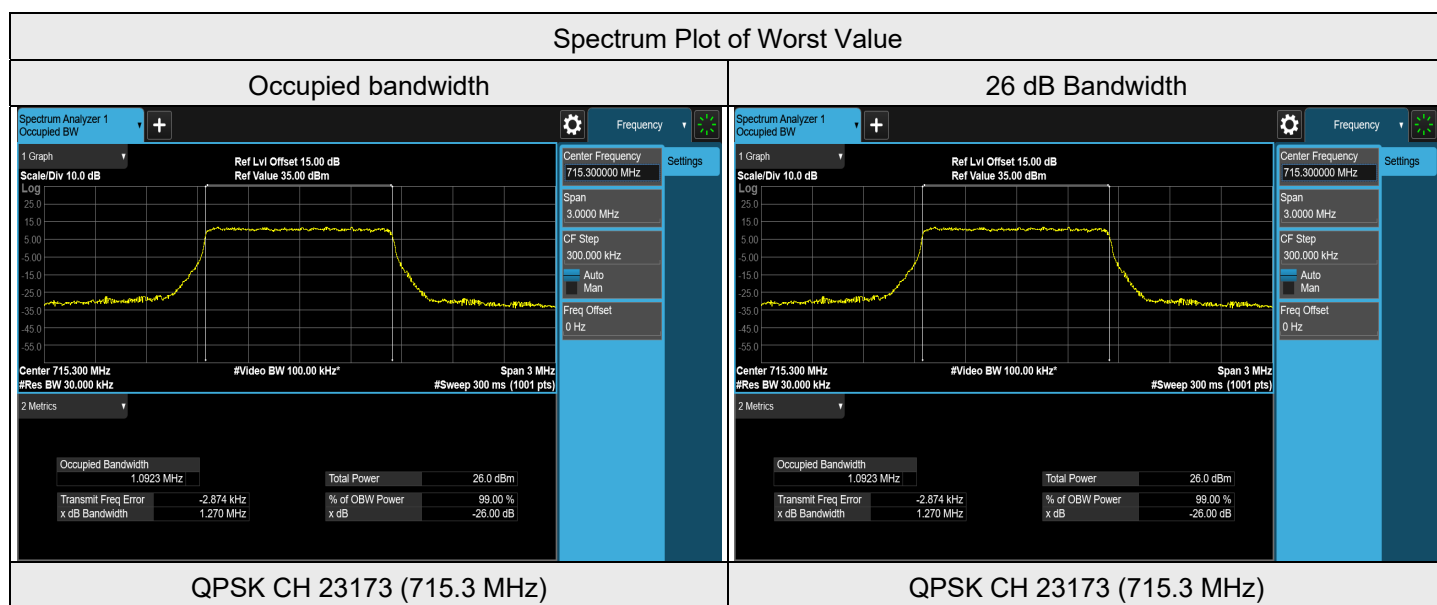

LTE Band 12, Channel Bandwidth: 3 MHz

Modulation	Channel	Frequency (MHz)	Occupied Bandwidth (MHz)	26 dB Bandwidth (MHz)
QPSK	23025	700.5	2.6998	2.869
QPSK	23095	707.5	2.6989	2.876
QPSK	23165	714.5	2.7003	2.872
16QAM	23025	700.5	2.6958	2.869
16QAM	23095	707.5	2.6987	2.882
16QAM	23165	714.5	2.6987	2.881
64QAM	23025	700.5	2.6982	2.870
64QAM	23095	707.5	2.6979	2.866
64QAM	23165	714.5	2.6964	2.870
256QAM	23025	700.5	2.6973	2.871
256QAM	23095	707.5	2.6994	2.877
256QAM	23165	714.5	2.6990	2.868

Spectrum Plot of Worst Value

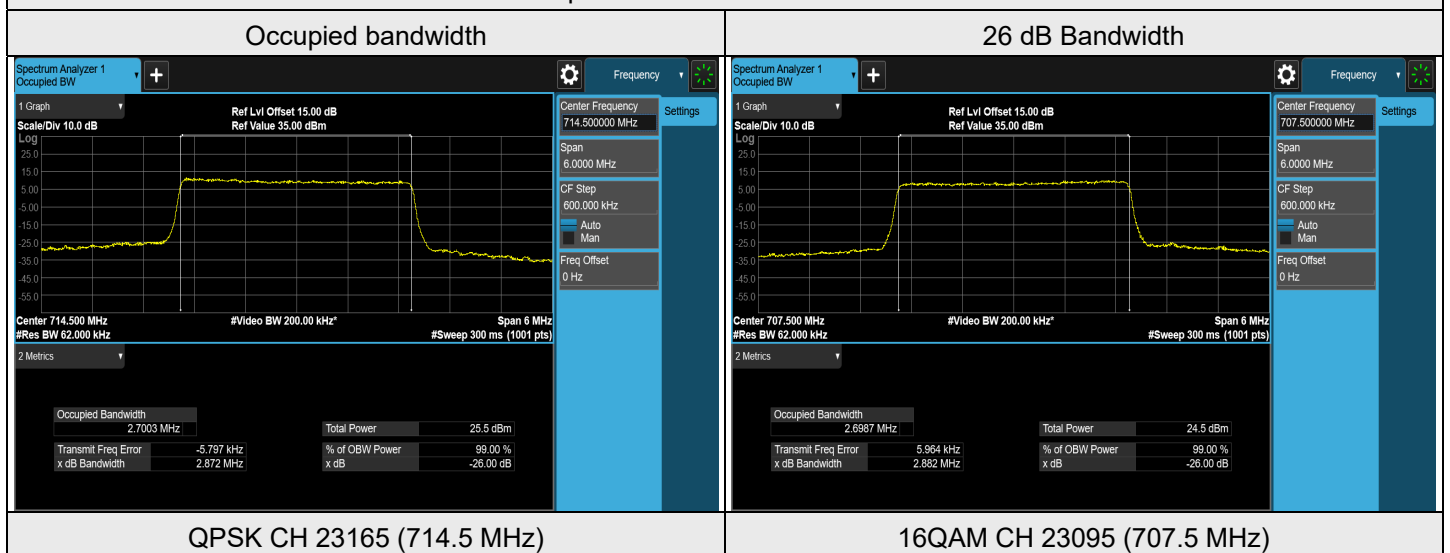

LTE Band 12, Channel Bandwidth: 5 MHz

Modulation	Channel	Frequency (MHz)	Occupied Bandwidth (MHz)	26 dB Bandwidth (MHz)
QPSK	23035	701.5	4.4962	4.780
QPSK	23095	707.5	4.4928	4.791
QPSK	23155	713.5	4.4897	4.789
16QAM	23035	701.5	4.4917	4.769
16QAM	23095	707.5	4.4885	4.778
16QAM	23155	713.5	4.4851	4.779
64QAM	23035	701.5	4.4981	4.784
64QAM	23095	707.5	4.4956	4.778
64QAM	23155	713.5	4.4896	4.788
256QAM	23035	701.5	4.4861	4.762
256QAM	23095	707.5	4.4898	4.789
256QAM	23155	713.5	4.4781	4.757

Spectrum Plot of Worst Value

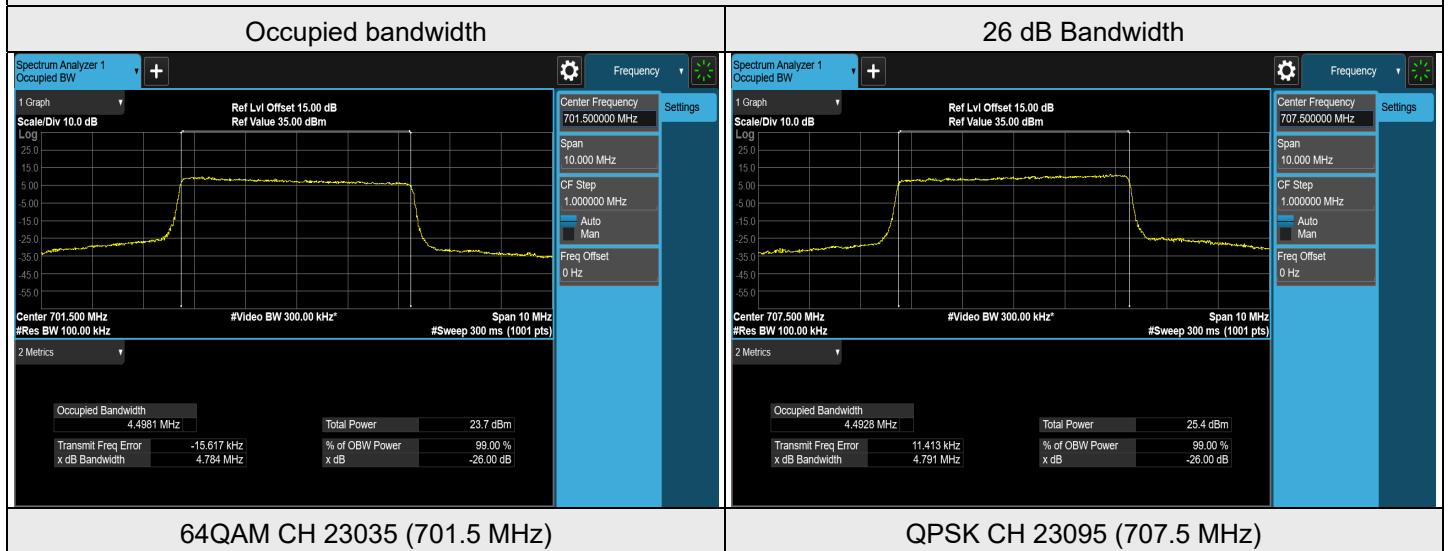

LTE Band 12, Channel Bandwidth: 10 MHz

Modulation	Channel	Frequency (MHz)	Occupied Bandwidth (MHz)	26 dB Bandwidth (MHz)
QPSK	23060	704	9.0250	9.532
QPSK	23095	707.5	8.9635	9.489
QPSK	23130	711	8.9102	9.460
16QAM	23060	704	9.0294	9.512
16QAM	23095	707.5	8.9665	9.472
16QAM	23130	711	8.9054	9.457
64QAM	23060	704	9.0284	9.541
64QAM	23095	707.5	8.9712	9.487
64QAM	23130	711	8.9099	9.451
256QAM	23060	704	9.0248	9.525
256QAM	23095	707.5	8.9702	9.484
256QAM	23130	711	8.8987	9.459

Spectrum Plot of Worst Value

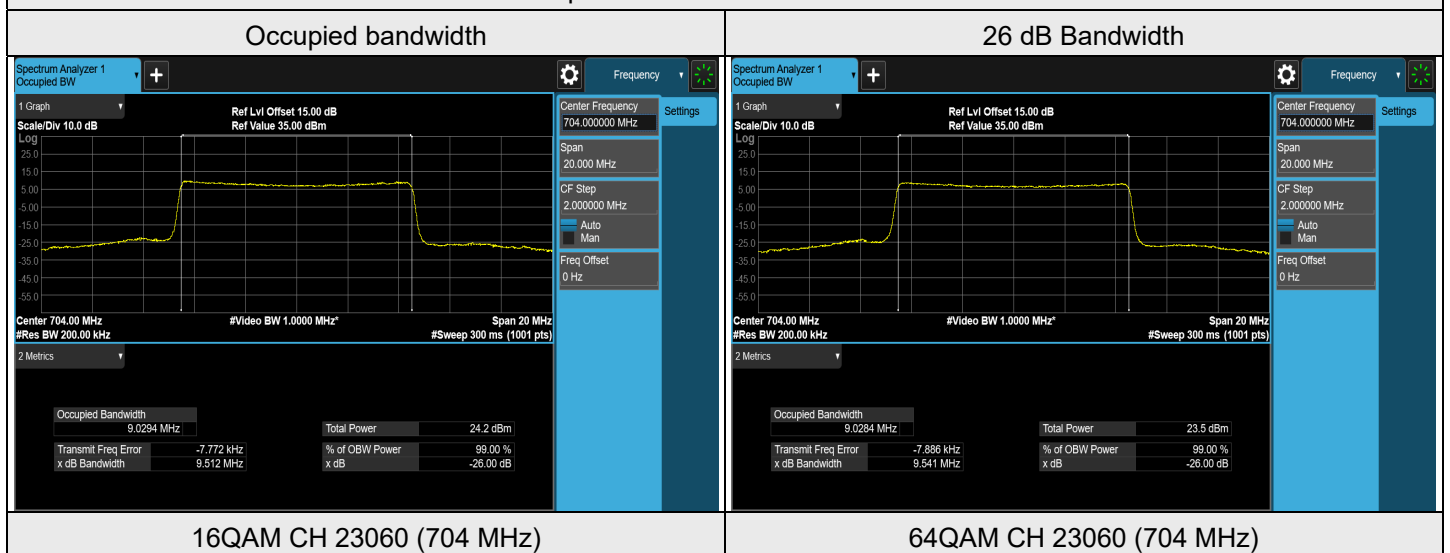

### 7.4.5 LTE Band 14

#### LTE Band 14, Channel Bandwidth: 5 MHz

Modulation	Channel	Frequency (MHz)	Occupied Bandwidth (MHz)	26 dB Bandwidth (MHz)
QPSK	23305	790.5	4.5139	5.730
QPSK	23330	793	4.4998	4.817
QPSK	23355	795.5	4.4896	4.803
16QAM	23305	790.5	4.5057	4.967
16QAM	23330	793	4.4934	4.791
16QAM	23355	795.5	4.4871	4.771
64QAM	23305	790.5	4.5041	4.852
64QAM	23330	793	4.5005	4.828
64QAM	23355	795.5	4.4931	4.793
256QAM	23305	790.5	4.4921	4.788
256QAM	23330	793	4.4890	4.777
256QAM	23355	795.5	4.4823	4.785

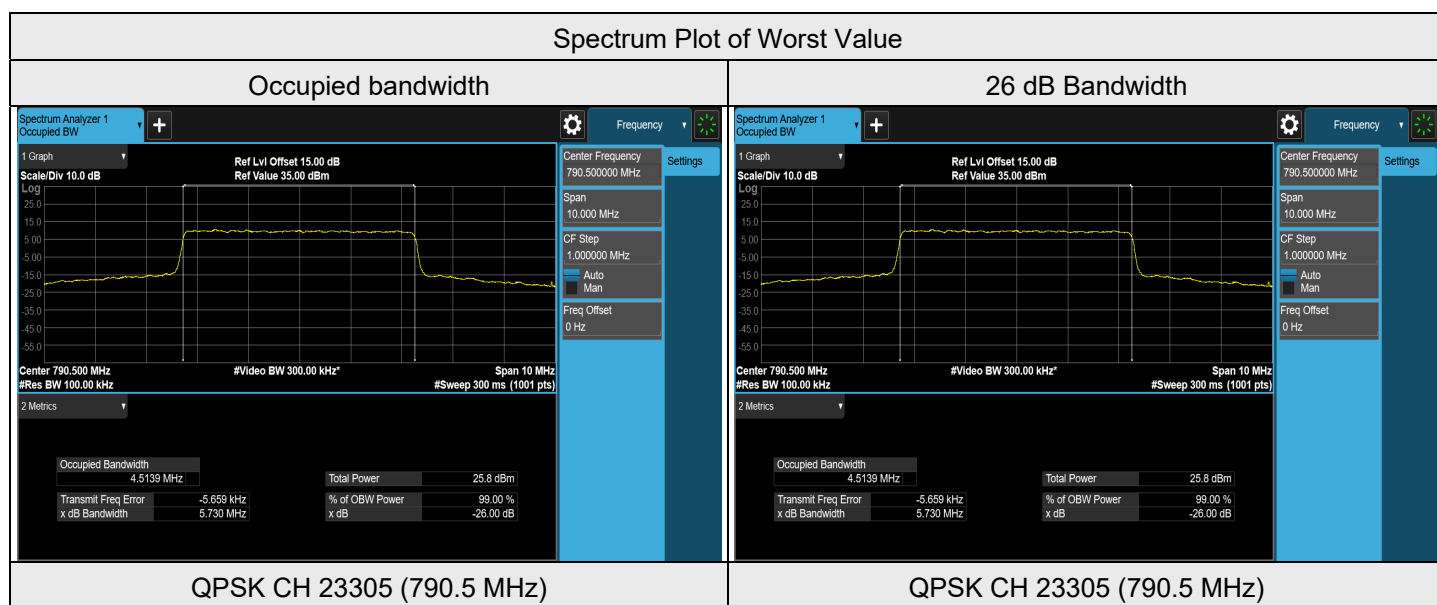

### LTE Band 14, Channel Bandwidth: 10 MHz

Modulation	Channel	Frequency (MHz)	Occupied Bandwidth (MHz)	26 dB Bandwidth (MHz)
QPSK	23330	793	9.0044	9.555
16QAM	23330	793	9.0025	9.527
64QAM	23330	793	9.0012	9.539
256QAM	23330	793	8.9949	9.517

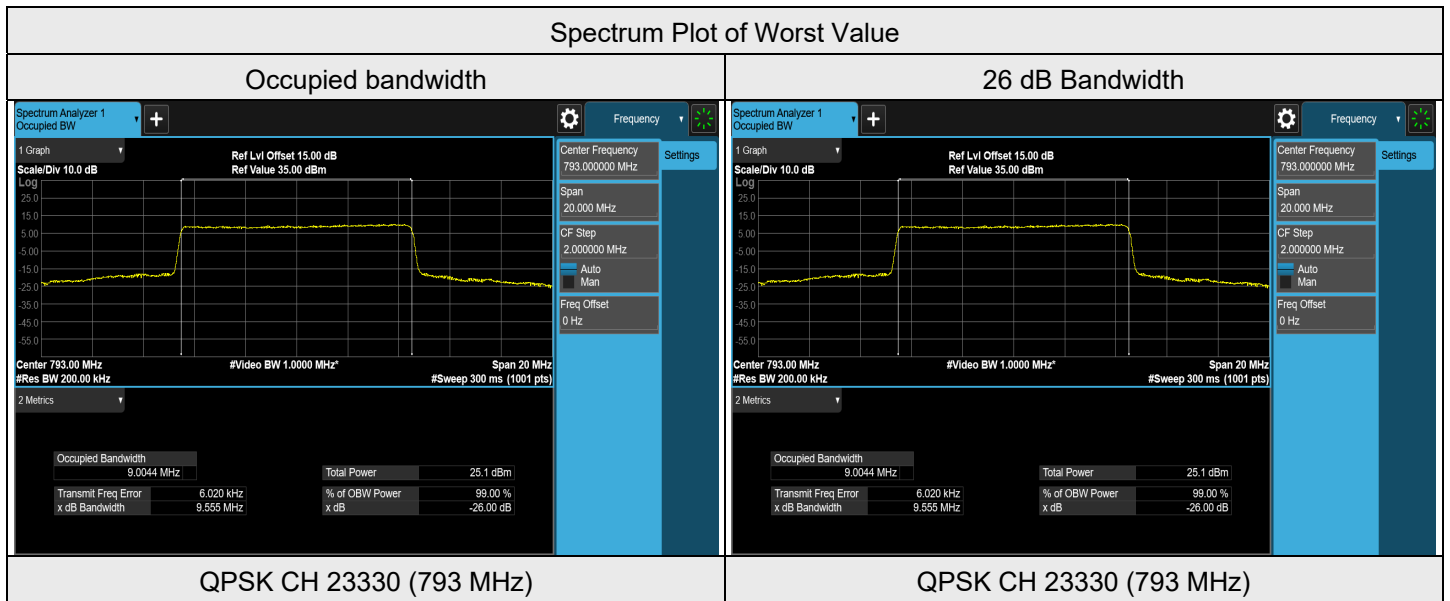

### 7.4.6 LTE Band 30

#### LTE Band 30, Channel Bandwidth: 5 MHz

Modulation	Channel	Frequency (MHz)	Occupied Bandwidth (MHz)	26 dB Bandwidth (MHz)
QPSK	27685	2307.5	4.4856	4.774
QPSK	27710	2310	4.4910	4.798
QPSK	27735	2312.5	4.4951	4.806
16QAM	27685	2307.5	4.4880	4.778
16QAM	27710	2310	4.4896	4.770
16QAM	27735	2312.5	4.4908	4.788
64QAM	27685	2307.5	4.4979	4.785
64QAM	27710	2310	4.4967	4.809
64QAM	27735	2312.5	4.4980	4.801
256QAM	27685	2307.5	4.4850	4.776
256QAM	27710	2310	4.4873	4.786
256QAM	27735	2312.5	4.4870	4.791

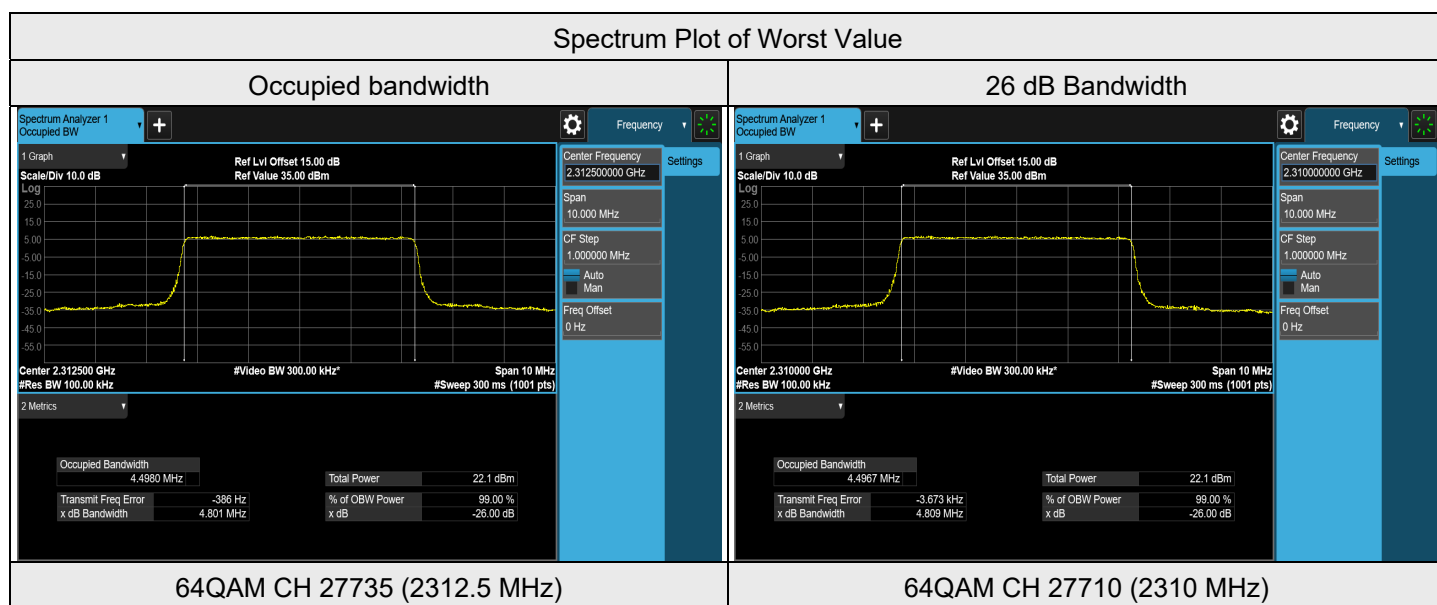

### LTE Band 30, Channel Bandwidth: 10 MHz

Modulation	Channel	Frequency (MHz)	Occupied Bandwidth (MHz)	26 dB Bandwidth (MHz)
QPSK	27710	2310	8.9759	9.507
16QAM	27710	2310	8.9772	9.503
64QAM	27710	2310	8.9790	9.514
256QAM	27710	2310	8.9705	9.508

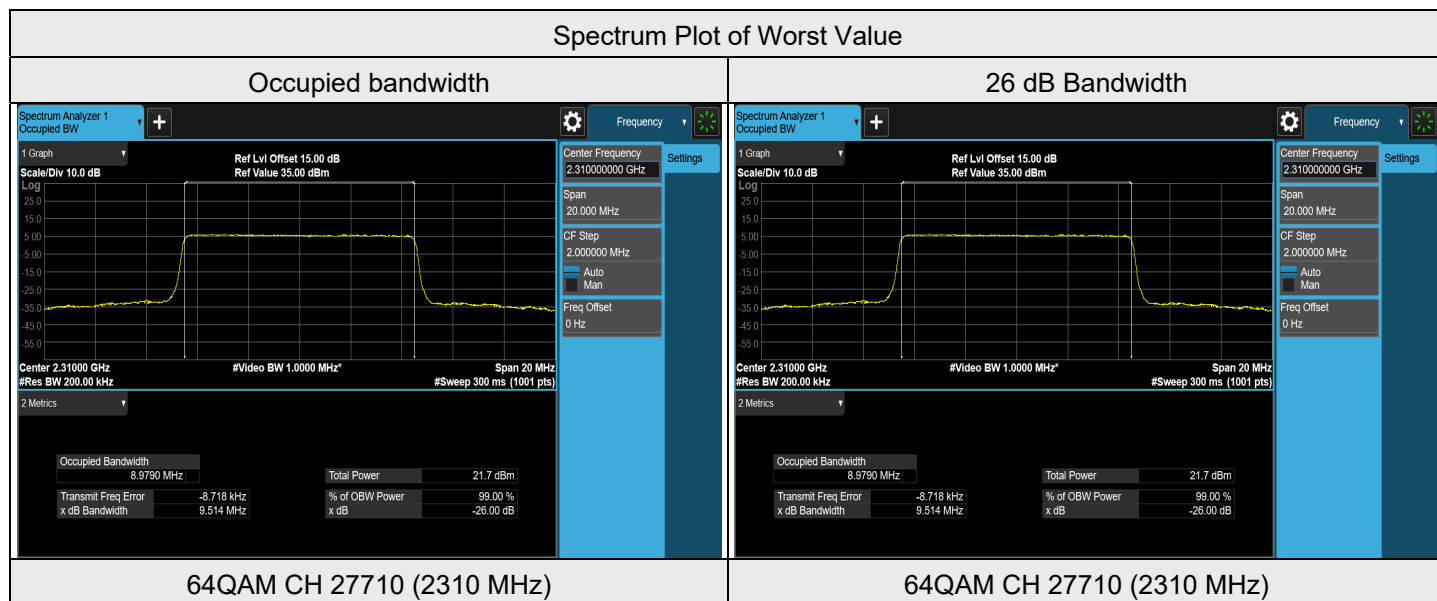



### 7.4.7 LTE Band 66

#### LTE Band 66, Channel Bandwidth: 1.4 MHz

Modulation	Channel	Frequency (MHz)	Occupied Bandwidth (MHz)	26 dB Bandwidth (MHz)
QPSK	131979	1710.7	1.0841	1.239
QPSK	132322	1745	1.0902	1.275
QPSK	132665	1779.3	1.0927	1.264
16QAM	131979	1710.7	1.0905	1.255
16QAM	132322	1745	1.0888	1.250
16QAM	132665	1779.3	1.0883	1.259
64QAM	131979	1710.7	1.0887	1.260
64QAM	132322	1745	1.0889	1.256
64QAM	132665	1779.3	1.0890	1.262
256QAM	131979	1710.7	1.0853	1.227
256QAM	132322	1745	1.0854	1.238
256QAM	132665	1779.3	1.0854	1.237

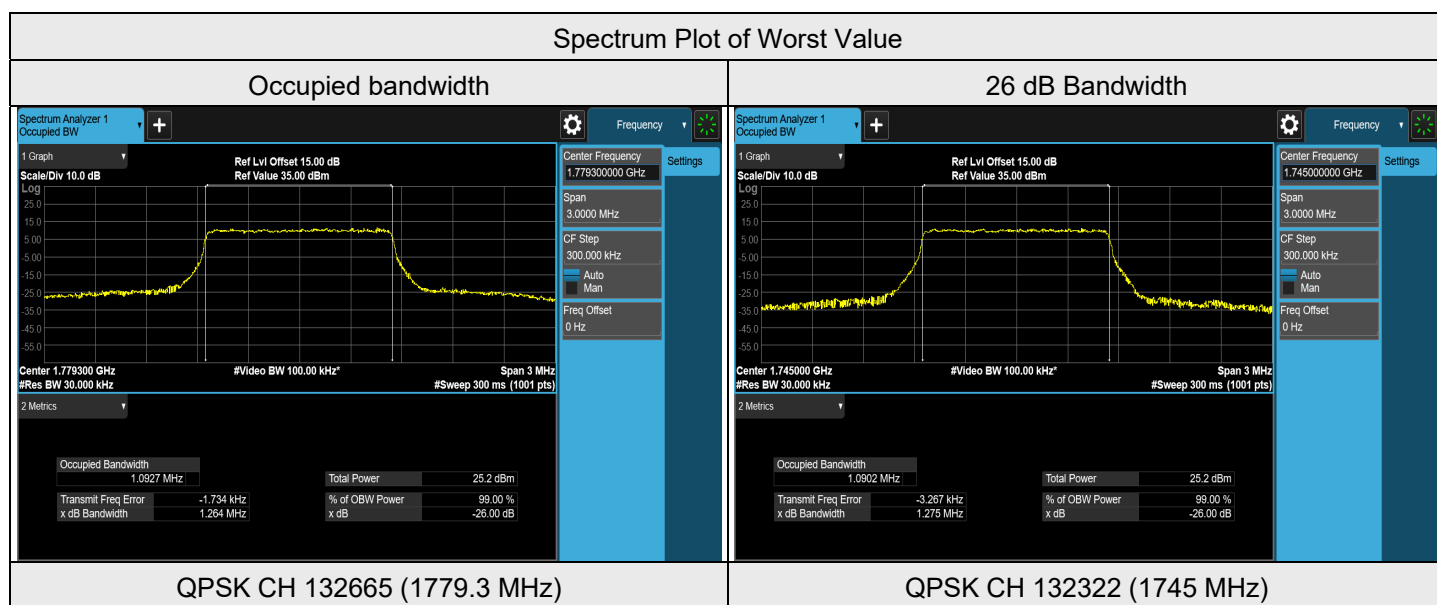

LTE Band 66, Channel Bandwidth: 3 MHz

Modulation	Channel	Frequency (MHz)	Occupied Bandwidth (MHz)	26 dB Bandwidth (MHz)
QPSK	131987	1711.5	2.7004	2.874
QPSK	132322	1745	2.6982	2.876
QPSK	132657	1778.5	2.6994	2.879
16QAM	131987	1711.5	2.6969	2.887
16QAM	132322	1745	2.6983	2.885
16QAM	132657	1778.5	2.6979	2.891
64QAM	131987	1711.5	2.6992	2.873
64QAM	132322	1745	2.6973	2.871
64QAM	132657	1778.5	2.6987	2.872
256QAM	131987	1711.5	2.6995	2.877
256QAM	132322	1745	2.6969	2.884
256QAM	132657	1778.5	2.6976	2.882

Spectrum Plot of Worst Value

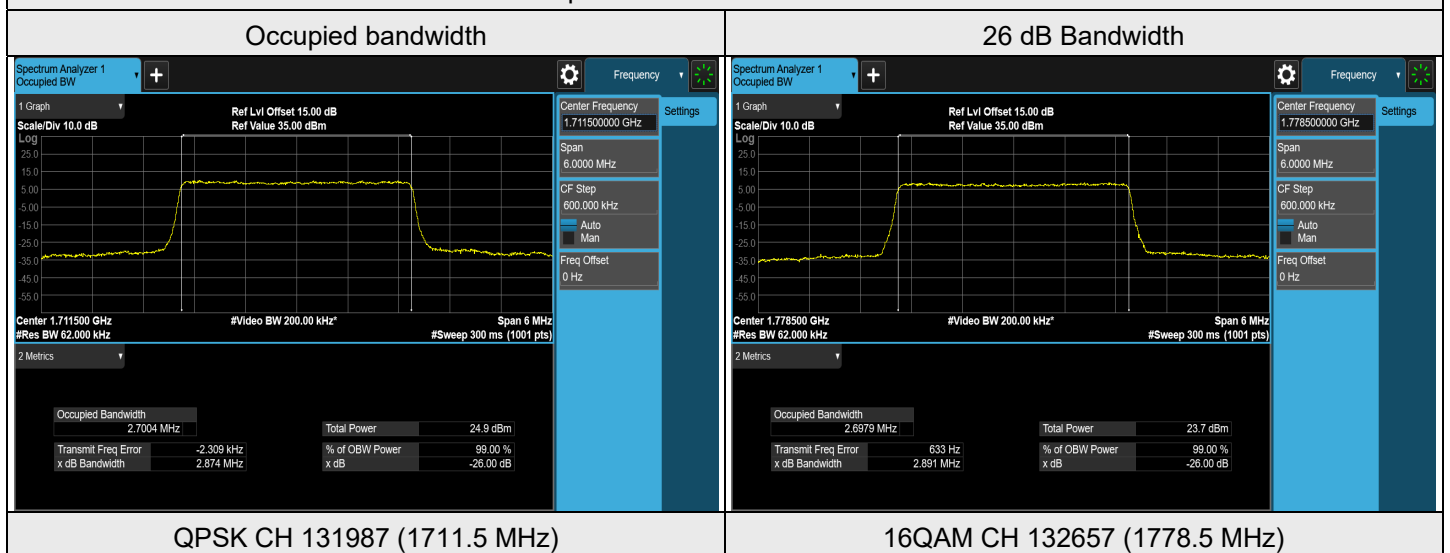

LTE Band 66, Channel Bandwidth: 5 MHz

Modulation	Channel	Frequency (MHz)	Occupied Bandwidth (MHz)	26 dB Bandwidth (MHz)
QPSK	131997	1712.5	4.4944	4.806
QPSK	132322	1745	4.4904	4.792
QPSK	132647	1777.5	4.4920	4.800
16QAM	131997	1712.5	4.4906	4.783
16QAM	132322	1745	4.4863	4.776
16QAM	132647	1777.5	4.4884	4.774
64QAM	131997	1712.5	4.4953	4.818
64QAM	132322	1745	4.4958	4.796
64QAM	132647	1777.5	4.4964	4.816
256QAM	131997	1712.5	4.4831	4.775
256QAM	132322	1745	4.4837	4.774
256QAM	132647	1777.5	4.4875	4.789

Spectrum Plot of Worst Value

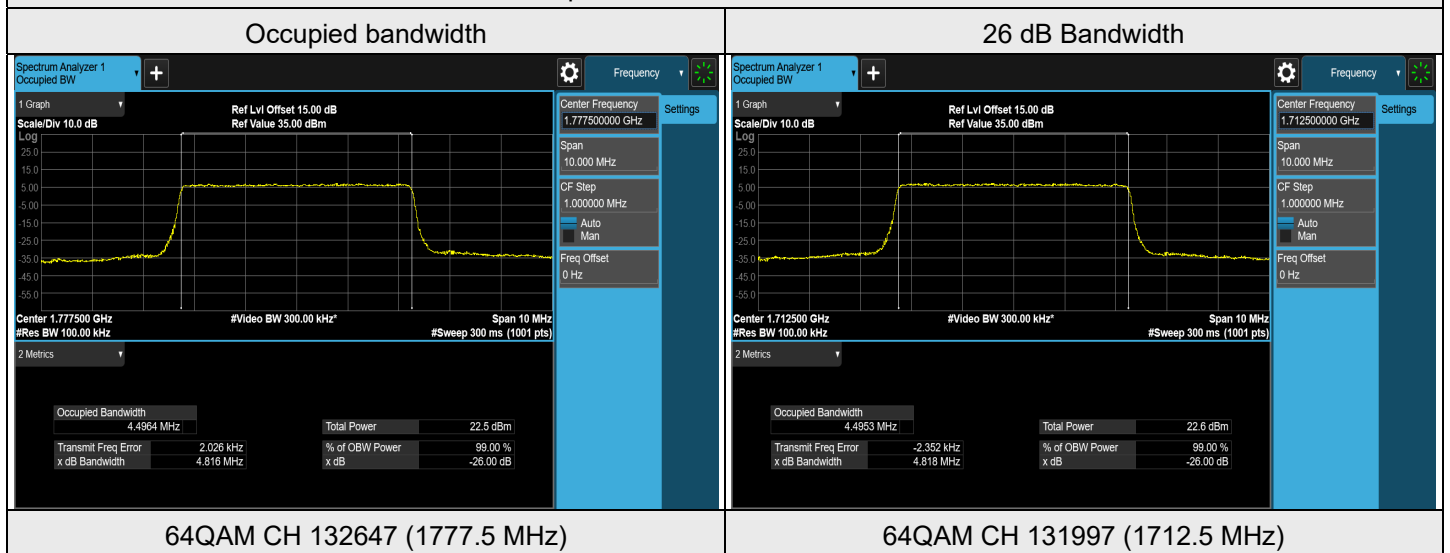

LTE Band 66, Channel Bandwidth: 10 MHz

Modulation	Channel	Frequency (MHz)	Occupied Bandwidth (MHz)	26 dB Bandwidth (MHz)
QPSK	132022	1715	8.9803	9.506
QPSK	132322	1745	8.9769	9.516
QPSK	132622	1775	8.9863	9.516
16QAM	132022	1715	8.9810	9.505
16QAM	132322	1745	8.9747	9.503
16QAM	132622	1775	8.9861	9.508
64QAM	132022	1715	8.9786	9.508
64QAM	132322	1745	8.9793	9.507
64QAM	132622	1775	8.9892	9.522
256QAM	132022	1715	8.9730	9.513
256QAM	132322	1745	8.9690	9.509
256QAM	132622	1775	8.9821	9.519

Spectrum Plot of Worst Value

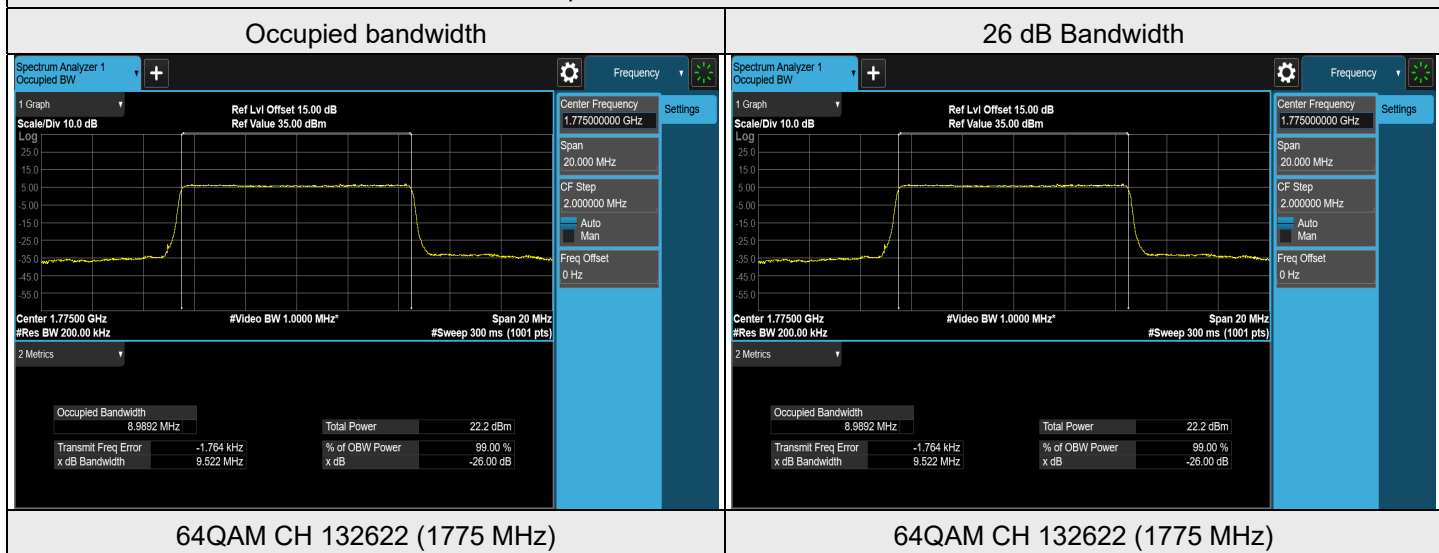

64QAM CH 132622 (1775 MHz)

64QAM CH 132622 (1775 MHz)

**LTE Band 66, Channel Bandwidth: 15 MHz**

Modulation	Channel	Frequency (MHz)	Occupied Bandwidth (MHz)	26 dB Bandwidth (MHz)
QPSK	132047	1717.5	13.4780	14.247
QPSK	132322	1745	13.4718	14.237
QPSK	132597	1772.5	13.4993	14.228
16QAM	132047	1717.5	13.4678	14.239
16QAM	132322	1745	13.4610	14.227
16QAM	132597	1772.5	13.4868	14.226
64QAM	132047	1717.5	13.4642	14.240
64QAM	132322	1745	13.4559	14.234
64QAM	132597	1772.5	13.4755	14.231
256QAM	132047	1717.5	13.4633	14.252
256QAM	132322	1745	13.4632	14.247
256QAM	132597	1772.5	13.4789	14.227

**Spectrum Plot of Worst Value**

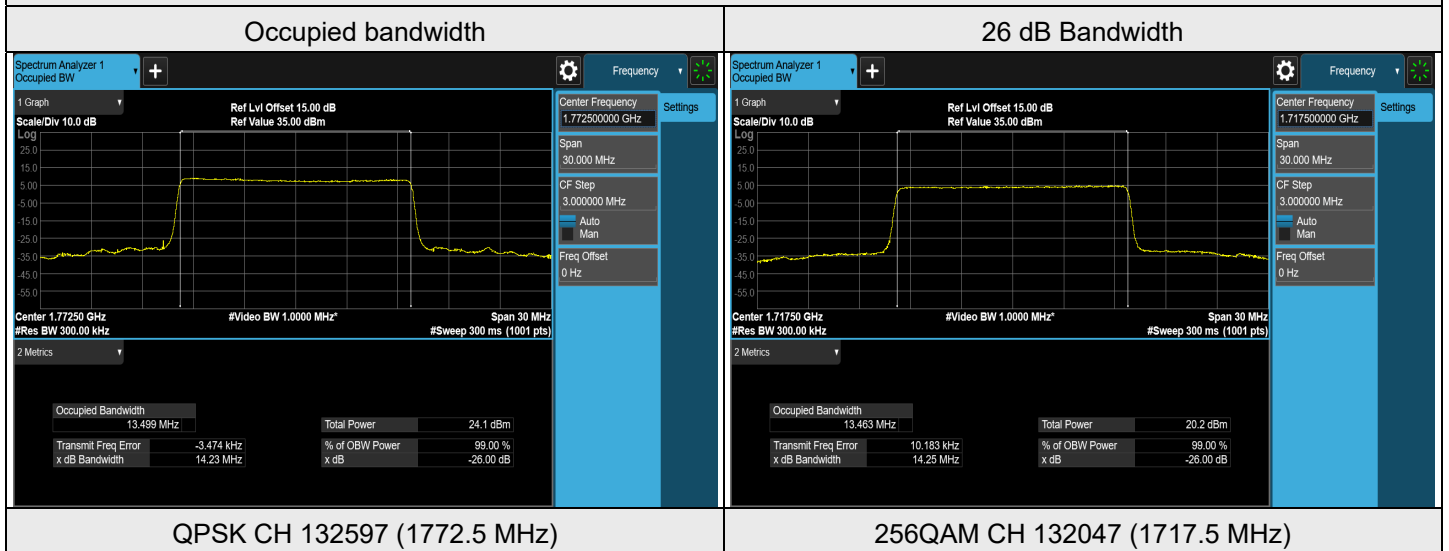

LTE Band 66, Channel Bandwidth: 20 MHz

Modulation	Channel	Frequency (MHz)	Occupied Bandwidth (MHz)	26 dB Bandwidth (MHz)
QPSK	132072	1720	17.9703	19.008
QPSK	132322	1745	17.9791	19.023
QPSK	132572	1770	17.9807	19.008
16QAM	132072	1720	17.9787	19.004
16QAM	132322	1745	17.9901	19.030
16QAM	132572	1770	17.9898	19.007
64QAM	132072	1720	17.9741	19.019
64QAM	132322	1745	17.9849	19.025
64QAM	132572	1770	17.9856	19.018
256QAM	132072	1720	17.9654	19.018
256QAM	132322	1745	17.9811	19.024
256QAM	132572	1770	17.9748	19.013

Spectrum Plot of Worst Value

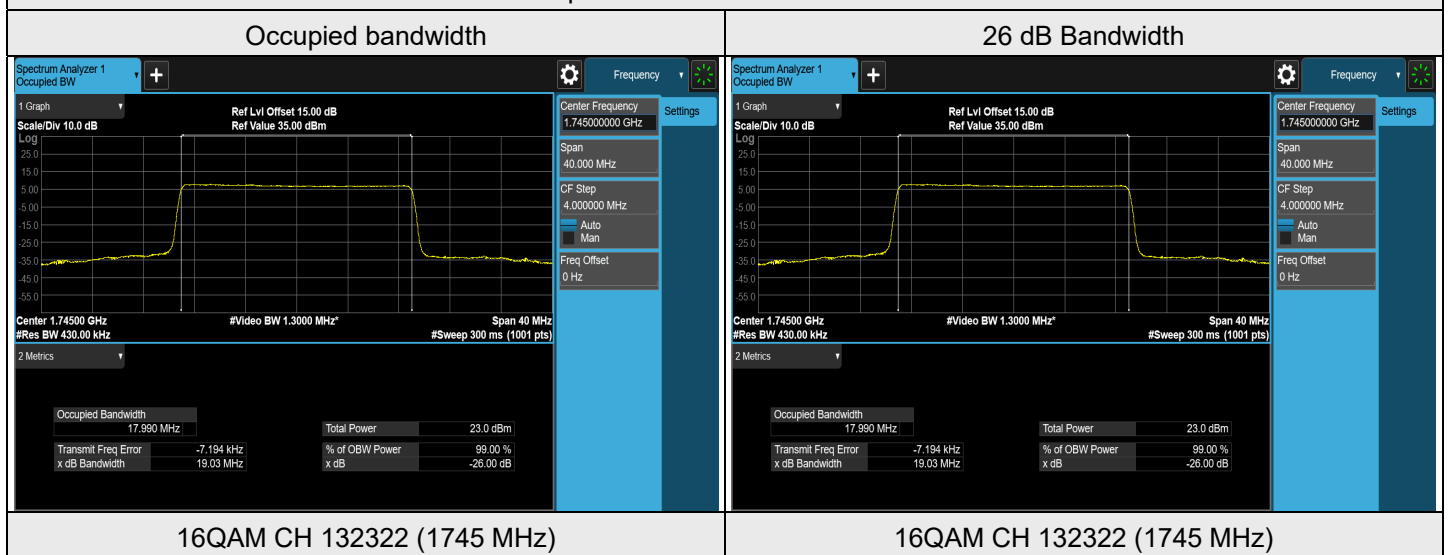

16QAM CH 132322 (1745 MHz)

16QAM CH 132322 (1745 MHz)



## 7.5 Conducted Spurious Emissions

Input Power:	120 Vac, 60 Hz	Environmental Conditions:	22°C, 74% RH	Tested By:	Willy Cheng
--------------	----------------	---------------------------	--------------	------------	-------------

### 7.5.1 LTE Band 2

#### LTE Band 2, Channel Bandwidth: 1.4 MHz

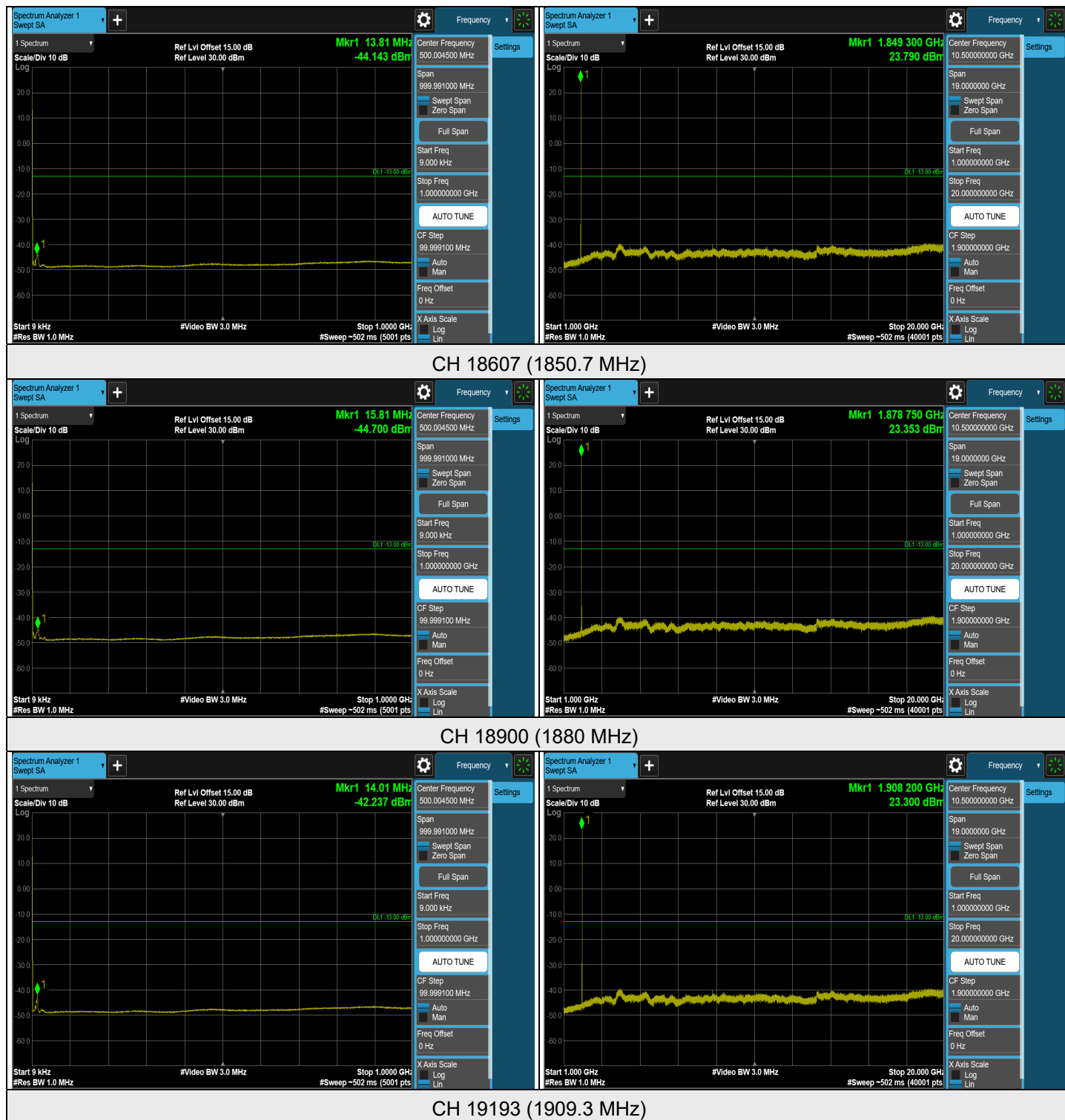

Note: The signal at 9 kHz is IF signal from spectrum analyzer.