

TEST REPORT

CERTIFICATE OF CONFORMITY

Standard: 47 CFR FCC Part 15, Subpart E (Section 15.407)
Report No.: RFBCUN-WTW-P21123242C-3
FCC ID: H8NEAO2522P-2
Product: Outdoor WiFi6 AP
Brand: ASKEY
Model No.: EAO2522P-2
Received Date: 2021/12/27
Test Date: 2021/12/28 ~ 2024/6/7
Issued Date: 2024/6/24

Applicant: ASKEY COMPUTER CORP.

Address: 10F, NO.119, JIANKANG RD., ZHONGHE DIST., NEW TAIPEI CITY 23585, TAIWAN, R.O.C.

Issued By: Bureau Veritas Consumer Products Services (H.K.) Ltd., Taoyuan Branch
Lin Kou Laboratories

Lab Address: No. 47-2, 14th Ling, Chia Pau Vil., Lin Kou Dist., New Taipei City, Taiwan

Test Location(1): No. 19, Hwa Ya 2nd Rd., Wen Hwa Vil., Kewi Shan Dist., Taoyuan City 33383, Taiwan

Test Location(2): No. 70, Wenming Rd., Guishan Dist., Taoyuan City 333, Taiwan (R.O.C.)

FCC Registration / 788550 / TW0003 for Test Location(1)

Designation Number: 281270 / TW0032 for Test Location(2)

Approved by: _____

Jeremy Lin

Jeremy Lin / Project Engineer

, Date: _____

2024/6/24

This test report consists of 139 pages in total. It may be duplicated completely for legal use with the approval of the applicant. It should not be reproduced except in full, without the written approval of our laboratory. The test results in the report only apply to the tested sample. The test results in this report are traceable to the national or international standards.

Prepared by : Gina Liu / Specialist



This report is governed by, and incorporates by reference, the Conditions of Testing as posted at the date of issuance of this report at <http://www.bureauveritas.com/home/about-us/our-business/cps/about-us/terms-conditions/> and is intended for your exclusive use. Any copying or replication of this report to or for any other person or entity, or use of our name or trademark, is permitted only with our prior written permission. This report sets forth our findings solely with respect to the test samples identified herein. The results set forth in this report are not indicative or representative of the quality or characteristics of the lot from which a test sample was taken or any similar or identical product unless specifically and expressly noted. Our report includes all of the tests requested by you and the results thereof based upon the information that you provided to us. Measurement uncertainty is only provided upon request for accredited tests. Statements of conformity are based on simple acceptance criteria without taking measurement uncertainty into account, unless otherwise requested in writing. You have 60 days from date of issuance of this report to notify us of any material error or omission caused by our negligence or if you require measurement uncertainty; provided, however, that such notice shall be in writing and shall specifically address the issue you wish to raise. A failure to raise such issue within the prescribed time shall constitute your unqualified acceptance of the completeness of this report, the tests conducted and the correctness of the report contents.

Table of Contents

Release Control Record	4
1 Certificate	5
2 Summary of Test Results	6
2.1 Measurement Uncertainty	7
2.2 Supplementary Information	7
3 General Information	8
3.1 General Description of EUT	8
3.2 Antenna Description of EUT	9
3.3 Channel List	10
3.4 Test Mode Applicability and Tested Channel Detail	12
3.5 Duty Cycle of Test Signal	14
3.6 Test Program Used and Operation Descriptions	15
3.7 Connection Diagram of EUT and Peripheral Devices	15
3.8 Configuration of Peripheral Devices and Cable Connections	15
4 Test Instruments	16
4.1 26 dB Bandwidth	16
4.2 RF Output Power	16
4.3 Power Spectral Density	16
4.4 6 dB Bandwidth	16
4.5 Occupied Bandwidth	16
4.6 Frequency Stability	17
4.7 AC Power Conducted Emissions	17
4.8 Unwanted Emissions below 1 GHz	18
4.9 Unwanted Emissions above 1 GHz	19
5 Limits of Test Items	20
5.1 26 dB Bandwidth	20
5.2 RF Output Power	20
5.3 Power Spectral Density	20
5.4 6 dB Bandwidth	20
5.5 Occupied Bandwidth	20
5.6 Frequency Stability	21
5.7 AC Power Conducted Emissions	21
5.8 Unwanted Emissions below 1 GHz	21
5.9 Unwanted Emissions above 1 GHz	22
6 Test Arrangements	24
6.1 26 dB Bandwidth	24
6.1.1 Test Setup	24
6.1.2 Test Procedure	24
6.2 RF Output Power	24
6.2.1 Test Setup	24
6.2.2 Test Procedure	24
6.3 Power Spectral Density	25
6.3.1 Test Setup	25
6.3.2 Test Procedure	25
6.4 6 dB Bandwidth	25
6.4.1 Test Setup	25
6.4.2 Test Procedure	25
6.5 Occupied Bandwidth	26
6.5.1 Test Setup	26
6.5.2 Test Procedure	26
6.6 Frequency Stability	26
6.6.1 Test Setup	26
6.6.2 Test Procedure	26
6.7 AC Power Conducted Emissions	27



6.7.1	Test Setup	27
6.7.2	Test Procedure	27
6.8	Unwanted Emissions below 1 GHz	28
6.8.1	Test Setup	28
6.8.2	Test Procedure	29
6.9	Unwanted Emissions above 1 GHz	30
6.9.1	Test Setup	30
6.9.2	Test Procedure	30
7	Test Results of Test Item	31
7.1	26 dB Bandwidth	31
7.2	RF Output Power	35
7.3	Power Spectral Density	51
7.4	6 dB Bandwidth	57
7.5	Occupied Bandwidth	59
7.6	Frequency Stability	65
7.7	AC Power Conducted Emissions	66
7.8	Unwanted Emissions below 1 GHz	68
7.9	Unwanted Emissions above 1 GHz	70
8	Pictures of Test Arrangements	138
9	Information of the Testing Laboratories	139



Release Control Record

Issue No.	Description	Date Issued
RFBCUN-WTW-P21123242C-3	Original release.	2024/6/24

1 Certificate

Product: Outdoor WiFi6 AP

Brand: ASKEY

Test Model: EAO2522P-2

Sample Status: Engineering sample

Applicant: ASKEY COMPUTER CORP.

Test Date: 2021/12/28 ~ 2024/6/7

Standard: 47 CFR FCC Part 15, Subpart E (Section 15.407)

Measurement ANSI C63.10-2013

procedure: KDB 789033 D02 General UNII Test Procedure New Rules v02r01

KDB 662911 D01 Multiple Transmitter Output v02r01

The above equipment has been tested by **Bureau Veritas Consumer Products Services (H.K.) Ltd., Taoyuan Branch**, and found compliance with the requirement of the above standards. The test record, data evaluation & Equipment Under Test (EUT) configurations represented herein are true and accurate accounts of the measurements of the sample's RF characteristics under the conditions specified in this report.

2 Summary of Test Results

47 CFR FCC Part 15, Subpart E (Section 15.407)			
Clause	Test Item	Result	Remark
15.407(a)(2)	26 dB Bandwidth	-	For U-NII-2A U-NII-2C Band output power limitation is determined based on 26dBc bandwidth.
15.407(a)(1) 15.407(a)(2) 15.407(a)(3)	RF Output Power	Pass	Meet the requirement of limit.
15.407(a)(1) 15.407(a)(2) 15.407(a)(3)	Power Spectral Density	Pass	Meet the requirement of limit.
15.407(e)	6 dB Bandwidth	Pass	Meet the requirement of limit. (U-NII-3 Band only)
---	Occupied Bandwidth	-	Reference only.
15.407(g)	Frequency Stability	Pass	Meet the requirement of limit.
15.407(b)(9)	AC Power Conducted Emissions	Pass	Minimum passing margin is -7.20 dB at 23.77000 MHz
15.407(b)(9)	Unwanted Emissions below 1 GHz	Pass	Minimum passing margin is -4.3 dB at 612.97 MHz
15.407(b) (1/10) 15.407(b) (2/10) 15.407(b) (3/10) 15.407(b) (4(i)/10)	Unwanted Emissions above 1 GHz	Pass	Minimum passing margin is -0.2 dB at 5350.00 MHz
15.203	Antenna Requirement	Pass	Antenna connector is ipex(MHF) not a standard connector.

Notes:

1. Determining compliance based on the results of the compliance measurement, not taking into account measurement instrumentation uncertainty.
2. The "Dynamic Frequency Selection measurement" was recorded in DFS test report.

2.1 Measurement Uncertainty

Where relevant, the following measurement uncertainty levels have been estimated for tests performed on the EUT as specified in CISPR 16-4-2:

Measurement	Specification	Expanded Uncertainty (k=2) (±)
26 dB Bandwidth	-	206.5 Hz
RF Output Power	-	1.371 dB
Power Spectral Density	-	1.017 dB
6 dB Bandwidth	-	206.5 Hz
Occupied Bandwidth	-	72 Hz
Frequency Stability	-	0.176 ppm
AC Power Conducted Emissions	9 kHz ~ 30 MHz	2.90 dB
Unwanted Emissions below 1 GHz	9 kHz ~ 30 MHz	3 dB
	30 MHz ~ 1 GHz	2.93 dB
Unwanted Emissions above 1 GHz	1 GHz ~ 18 GHz	1.76 dB
	18 GHz ~ 40 GHz	1.77 dB

The other instruments specified are routine verified to remain within the calibrated levels, no measurement uncertainty is required to be calculated.

2.2 Supplementary Information

There is not any deviation from the test standards for the test method, and no modifications required for compliance.

3 General Information

3.1 General Description of EUT

Product	Outdoor WiFi6 AP
Brand	ASKEY
Test Model	EAO2522P-2
Status of EUT	Engineering sample
Power Supply Rating	50-57 Vdc (POE)
Modulation Type	64QAM, 16QAM, QPSK, BPSK for OFDM 256QAM for OFDM in 11ac mode 1024QAM for OFDMA in 11ax mode
Modulation Technology	OFDM, OFDMA
Transfer Rate	802.11a: 54.0/ 48.0/ 36.0/ 24.0/ 18.0/ 12.0/ 9.0/ 6.0 Mbps 802.11n: up to 300.0 Mbps 802.11ac: up to 866.7 Mbps 802.11ax: up to 1201.0 Mbps
Operating Frequency	5.18 GHz ~ 5.24 GHz 5.26 GHz ~ 5.32 GHz 5.5 GHz ~ 5.72 GHz 5.745 GHz ~ 5.825 GHz
Number of Channel	802.11a, 802.11n (HT20), 802.11ac (VHT20), 802.11ax (HE20): 25 802.11n (HT40), 802.11ac (VHT40), 802.11ax (HE40): 12 802.11ac (VHT80), 802.11ax (HE80): 6
Output Power	CDD mode 5.18 GHz ~ 5.24 GHz : 52.803 mW (17.23 dBm) 5.26 GHz ~ 5.32 GHz : 219.045 mW (23.41 dBm) 5.5 GHz ~ 5.72 GHz : 156.816 mW (21.95 dBm) 5.745 GHz ~ 5.825 GHz : 707.073 mW (28.49 dBm) Beamforming Mode 5.18 GHz ~ 5.24 GHz : 32.187 mW (15.08 dBm) 5.26 GHz ~ 5.32 GHz : 115.349 mW (20.62 dBm) 5.5 GHz ~ 5.72 GHz : 89.763 mW (19.53 dBm) 5.745 GHz ~ 5.825 GHz : 366.56 mW (25.64 dBm)
EUT Category	Outdoor Access Point

Note: The above EUT information is declared by manufacturer and for more detailed features description, please refers to the manufacturer's specifications or user's manual.

3.2 Antenna Description of EUT

1. The antenna information is listed as below.

Antenna No.	Brand	Model	Gain (dBi)				Antenna Type	Connector Type
			5.15~5.25 GHz	5.25~5.35 GHz	5.47~5.725 GHz	5.725~5.85 GHz		
Ant 8	Airgain	N02AKAWC	6.3	6.5	7.5	7.5	Dipole	ipex(MHF)
Ant 9	Airgain	N02AKAWH	5.4	5.8	6.9	6.9	Dipole	ipex(MHF)

2. The EUT will install at outdoor area, the highest antenna gain from the horizon above 30 degrees as below, for more detail information please refer to antenna specification and user manual.

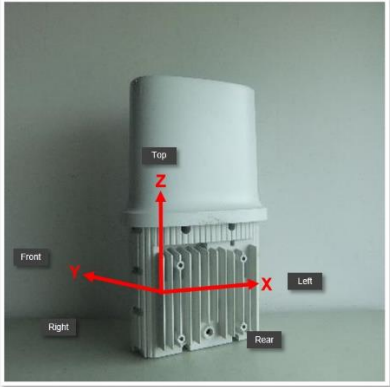
Antenna Model	Antenna gain (dBi)	Antenna install degree
N02AKAWC	1.53	 <i>Orientation of EAO2522P</i>
N02AKAWH	3.46	

* Due to device Will restricted installation position as above photo, thus consider to above 30 degrees highest antenna gain are chosen from XZ and YZ Plane (antenna specification of 30~150 deg)

* Detail antenna specification please refer to antenna datasheet and/or antenna measurement report.

3. The EUT incorporates a MIMO function:

Modulation Mode	5 GHz Band	
	TX & RX Configuration	
802.11a	2TX	2RX
802.11n (HT20)	2TX	2RX
802.11n (HT40)	2TX	2RX
802.11ac (VHT20)	2TX	2RX
802.11ac (VHT40)	2TX	2RX
802.11ac (VHT80)	2TX	2RX
802.11ax (HE20)	2TX	2RX
802.11ax (HE40)	2TX	2RX
802.11ax (HE80)	2TX	2RX

Note:

- All of modulation mode support beamforming function except 802.11a modulation mode.
- The EUT support Beamforming and CDD mode, therefore both mode were investigated and the worst case scenario was identified. The worst case data were presented in test report.
- The modulation and bandwidth are similar for 802.11n mode for 20 MHz (40 MHz), 802.11ac mode for 20 MHz (40 MHz, 80 MHz), 802.11ax mode for 20 MHz (40 MHz, 80 MHz) therefore the manufacturer will control the power for 802.11n/ac mode is same as the 802.11ax mode or lower than it and investigated worst case to representative mode in test report.
- The EUT not support Partial RU mode.

3.3 Channel List

FOR 5180 ~ 5320 MHz

8 channels are provided for 802.11a, 802.11n (HT20), 802.11ac (VHT20), 802.11ax (HE20):

Channel	Frequency	Channel	Frequency
36	5180 MHz	52	5260 MHz
40	5200 MHz	56	5280 MHz
44	5220 MHz	60	5300 MHz
48	5240 MHz	64	5320 MHz

4 channels are provided for 802.11n (HT40), 802.11ac (VHT40), 802.11ax (HE40):

Channel	Frequency	Channel	Frequency
38	5190 MHz	54	5270 MHz
46	5230 MHz	62	5310 MHz

2 channels are provided for 802.11ac (VHT80), 802.11ax (HE80):

Channel	Frequency	Channel	Frequency
42	5210 MHz	58	5290 MHz

FOR 5500 ~ 5720 MHz

12 channels are provided for 802.11a, 802.11n (HT20), 802.11ac (VHT20), 802.11ax (HE20):

Channel	Frequency	Channel	Frequency
100	5500 MHz	124	5620 MHz
104	5520 MHz	128	5640 MHz
108	5540 MHz	132	5660 MHz
112	5560 MHz	136	5680 MHz
116	5580 MHz	140	5700 MHz
120	5600 MHz	144	5720 MHz

6 channels are provided for 802.11n (HT40), 802.11ac (VHT40), 802.11ax (HE40):

Channel	Frequency	Channel	Frequency
102	5510 MHz	126	5630 MHz
110	5550 MHz	134	5670 MHz
118	5590 MHz	142	5710 MHz

3 channels are provided for 802.11ac (VHT80), 802.11ax (HE80):

Channel	Frequency	Channel	Frequency
106	5530 MHz	138	5690 MHz
122	5610 MHz		

FOR 5745 ~ 5825 MHz:

5 channels are provided for 802.11a, 802.11n (HT20), 802.11ac (VHT20), 802.11ax (HE20):

Channel	Frequency	Channel	Frequency
149	5745 MHz	161	5805 MHz
153	5765 MHz	165	5825 MHz
157	5785 MHz		

2 channels are provided for 802.11n (HT40), 802.11ac (VHT40), 802.11ax (HE40):

Channel	Frequency	Channel	Frequency
151	5755 MHz	159	5795 MHz

1 channel is provided for 802.11ac (VHT80), 802.11ax (HE80):

Channel	Frequency
155	5775 MHz

3.4 Test Mode Applicability and Tested Channel Detail

Following channel(s) was (were) selected for the final test as listed below:

Test Item	Mode	Signal Mode	Tested Channel	Modulation	Data Rate Parameter
26 dB Bandwidth	802.11a	CDD	52, 60, 64, 100, 116, 140, 144	BPSK	6Mb/s
	802.11ax (HE20)	CDD	52, 60, 64, 100, 116, 140, 144	BPSK	MCS0
	802.11ax (HE40)	CDD	54, 62, 102, 110, 134, 142	BPSK	MCS0
	802.11ax (HE80)	CDD	58, 106, 122, 138	BPSK	MCS0
RF Output Power	802.11a	CDD	36, 40, 48, 52, 60, 64, 100, 116, 140, 144, 149, 157, 165	BPSK	6Mb/s
	802.11ac (VHT20)	CDD & Beamforming	36, 40, 48, 52, 60, 64, 100, 116, 140, 144, 149, 157, 165	BPSK	MCS0
	802.11ac (VHT40)	CDD & Beamforming	38, 46, 54, 62, 102, 110, 134, 142, 151, 159	BPSK	MCS0
	802.11ac (VHT80)	CDD & Beamforming	42, 58, 106, 122, 138, 155	BPSK	MCS0
	802.11ax (HE20)	CDD & Beamforming	36, 40, 48, 52, 60, 64, 100, 116, 140, 144, 149, 157, 165	BPSK	MCS0
	802.11ax (HE40)	CDD & Beamforming	38, 46, 54, 62, 102, 110, 134, 142, 151, 159	BPSK	MCS0
	802.11ax (HE80)	CDD & Beamforming	42, 58, 106, 122, 138, 155	BPSK	MCS0
Power Spectral Density	802.11a	CDD	36, 40, 48, 52, 60, 64, 100, 116, 140, 144, 149, 157, 165	BPSK	6Mb/s
	802.11ax (HE20)	CDD	36, 40, 48, 52, 60, 64, 100, 116, 140, 144, 149, 157, 165	BPSK	MCS0
	802.11ax (HE40)	CDD	38, 46, 54, 62, 102, 110, 134, 142, 151, 159	BPSK	MCS0
	802.11ax (HE80)	CDD	42, 58, 106, 122, 138, 155	BPSK	MCS0
6 dB Bandwidth	802.11a	CDD	144, 149, 157, 165	BPSK	6Mb/s
	802.11ax (HE20)	CDD	144, 149, 157, 165	BPSK	MCS0
	802.11ax (HE40)	CDD	142, 151, 159	BPSK	MCS0
	802.11ax (HE80)	CDD	138, 155	BPSK	MCS0

Test Item	Mode	Signal Mode	Tested Channel	Modulation	Data Rate Parameter
Occupied Bandwidth	802.11a	CDD	36, 40, 48, 52, 60, 64, 100, 116, 140, 144, 149, 157, 165	BPSK	6Mb/s
	802.11ax (HE20)	CDD	36, 40, 48, 52, 60, 64, 100, 116, 140, 144, 149, 157, 165	BPSK	MCS0
	802.11ax (HE40)	CDD	38, 46, 54, 62, 102, 110, 134, 142, 151, 159	BPSK	MCS0
	802.11ax (HE80)	CDD	42, 58, 106, 122, 138, 155	BPSK	MCS0
Frequency Stability	802.11a	-	36	unmodulated	-
AC Power Conducted Emissions	802.11ax (HE20)	CDD	157	BPSK	MCS0
Unwanted Emissions below 1 GHz	802.11ax (HE20)	CDD	157	BPSK	MCS0
Unwanted Emissions above 1 GHz	802.11a	CDD	36, 40, 48, 52, 60, 64, 100, 116, 140, 144, 149, 157, 165	BPSK	6Mb/s
	802.11ax (HE20)	CDD	36, 40, 48, 52, 60, 64, 100, 116, 140, 144, 149, 157, 165	BPSK	MCS0
	802.11ax (HE40)	CDD	38, 46, 54, 62, 102, 110, 134, 142, 151, 159	BPSK	MCS0
	802.11ax (HE80)	CDD	42, 58, 106, 122, 138, 155	BPSK	MCS0

Note: The EUT is device Will restricted installation position, the EUT was positioned on the z-axis during testing.



3.5 Duty Cycle of Test Signal

802.11a: Duty cycle = 1.961 ms / 2.065 ms x 100% = 95.0%, duty factor = 10 * log (1/Duty cycle) = 0.22 dB

802.11ax (HE20): Duty cycle = 5.416 ms / 5.779 ms x 100% = 93.7%, duty factor = 10 * log (1/Duty cycle) = 0.28 dB

802.11ax (HE40): Duty cycle = 5.432 ms / 5.768 ms x 100% = 94.2%, duty factor = 10 * log (1/Duty cycle) = 0.26 dB

802.11ax (HE80): Duty cycle = 5.418 ms / 5.737 ms x 100% = 94.4%, duty factor = 10 * log (1/Duty cycle) = 0.25 dB



3.6 Test Program Used and Operation Descriptions

Controlling software QSPR Version 5.0-00197 has been activated to set the EUT under transmission condition continuously at specific channel frequency.

3.7 Connection Diagram of EUT and Peripheral Devices

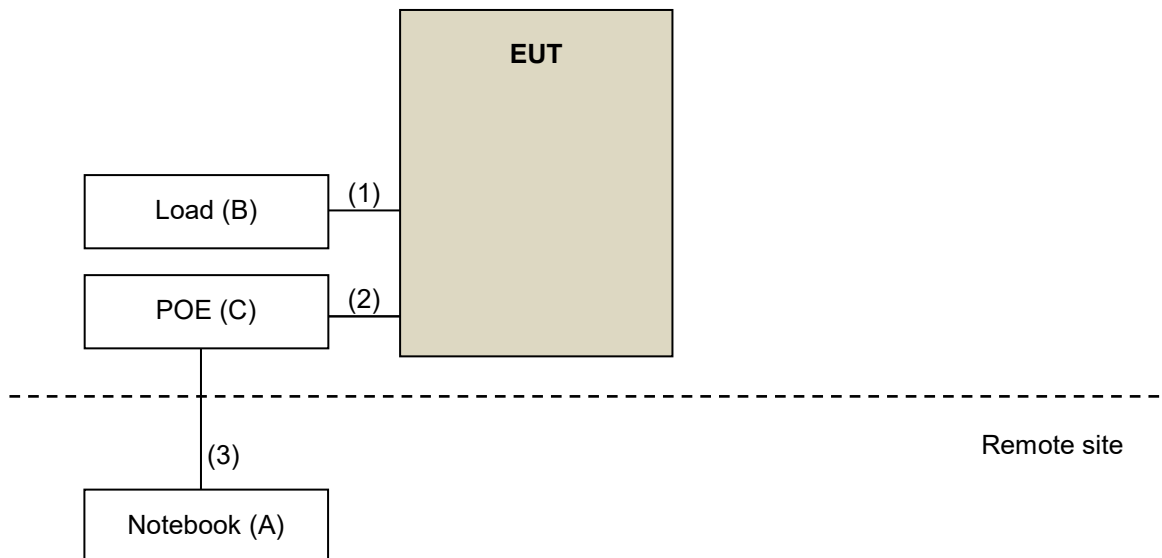

3.8 Configuration of Peripheral Devices and Cable Connections

ID	Product	Brand	Model No.	Serial No.	FCC ID	Remarks
A	Notebook	DELL	E5420	76WNBT1	N/A	--
B	Load	N/A	N/A	N/A	N/A	--
C	POE	Delta	ADH-45AR B	N/A	N/A	Provided by client

ID	Cable Descriptions	Qty.	Length (m)	Shielding (Yes/No)	Cores (Qty.)	Remarks
1	LAN Cable	1	1.5	N	0	RJ45, Cat5e
2	LAN Cable	1	1.5	N	0	RJ45, Cat5e
3	LAN Cable	1	6	N	0	RJ45, Cat5e

4 Test Instruments

The calibration interval of the all test instruments are 12 months and the calibrations are traceable to NML/ROC and NIST/USA.

4.1 26 dB Bandwidth

Description Manufacturer	Model No.	Serial No.	Calibrated Date	Calibrated Until
Signal & Spectrum Analyzer R&S	FSV3044	101105	2024/2/27	2025/2/26
Software BV	ADT_RF Test Software V7.6.5.4	N/A	N/A	N/A

Notes:

1. The test was performed in Oven room.
2. Tested Date: 2024/6/7

4.2 RF Output Power

Description Manufacturer	Model No.	Serial No.	Calibrated Date	Calibrated Until
Peak Power Analyzer Keysight	8990B	MY51000485	2024/1/21	2025/1/20
Signal & Spectrum Analyzer R&S	FSV3044	101105	2024/2/27	2025/2/26
Software BV	ADT_RF Test Software V7.6.5.4	N/A	N/A	N/A
Wideband Power Sensor Keysight	N1923A	MY58020002	2024/1/18	2025/1/17
		MY58140009	2024/1/18	2025/1/17

Notes:

1. The test was performed in Oven room.
2. Tested Date: 2024/6/7

4.3 Power Spectral Density

Refer to section 4.1 to get the tested date and information of the instruments.

4.4 6 dB Bandwidth

Refer to section 4.1 to get the tested date and information of the instruments.

4.5 Occupied Bandwidth

Refer to section 4.1 to get the tested date and information of the instruments.

4.6 Frequency Stability

Description Manufacturer	Model No.	Serial No.	Calibrated Date	Calibrated Until
3-channel DC power supply JIN YIH Technology	ODP3033	ODP30332128138	N/A	N/A
Digital Multimeter Fluke	87III	70360742	2023/7/6	2024/7/5
Signal & Spectrum Analyzer R&S	FSV3044	101105	2024/2/27	2025/2/26
Software BV	ADT_RF Test Software V7.6.5.4	N/A	N/A	N/A
Temperature & Humidity Chamber Terchy	HRM-120RF	931022	2023/12/19	2024/12/18

Notes:

1. The test was performed in Oven room.
2. Tested Date: 2024/6/7

4.7 AC Power Conducted Emissions

Description Manufacturer	Model No.	Serial No.	Calibrated Date	Calibrated Until
50 ohm terminal resistance HUBER+SUHNER	E1-011315	13	2023/11/22	2024/11/21
50 ohm terminal resistance	E1-011279	04	2023/11/22	2024/11/21
	E1-011280	05	2023/11/22	2024/11/21
DC-LISN Schwarzbeck	NNBM 8126G	8126G-069	2023/11/7	2024/11/6
EMI Test Receiver R&S	ESCI	100613	2023/12/4	2024/12/3
Fixed Attenuator Mini-Circuits	HAT-10+	PAD-COND1-01	2024/1/6	2025/1/5
LISN R&S	ENV216	101826	2024/3/25	2025/3/24
	ESH3-Z5	100311	2023/9/6	2024/9/5
RF Coaxial Cable Woken	5D-FB	Cable-cond1-01	2024/1/6	2025/1/5
Software BVADT	BVADT_Cond_ V7.4.1.0	N/A	N/A	N/A
V-LISN Schwarzbeck	NNBL 8226-2	8226-142	2023/8/31	2024/8/30

Notes:

1. The test was performed in HY - Conduction 1.
2. Tested Date: 2024/6/6

4.8 Unwanted Emissions below 1 GHz

Description Manufacturer	Model No.	Serial No.	Calibrated Date	Calibrated Until
Antenna Tower Max-Full	MFT-151SS-0.5T	N/A	N/A	N/A
Bi_Log Antenna Schwarzbeck	VULB 9168	9168-1213	2023/10/13	2024/10/12
EMI Test Receiver R&S	ESR3	102782	2023/12/7	2024/12/6
Loop Antenna Electro-Metrics	EM-6879	269	2023/9/23	2024/9/22
Loop Antenna TESEQ	HLA 6121	45745	2023/8/8	2024/8/7
MXA Signal Analyzer Keysight	N9020B	MY60110513	2023/12/22	2024/12/21
Preamplifier EMCI	EMC330N	980782	2024/1/15	2025/1/14
	EMC001340	980201	2023/9/27	2024/9/26
RF Coaxial Cable EMCI	EMCCFD400-NM-NM- 500	201233	2024/1/15	2025/1/14
	EMCCFD400-NM-NM- 3000	201235	2024/1/15	2025/1/14
	EMCCFD400-NM-NM- 9000	201236(with PAD)	2024/1/15	2025/1/14
Software BV ADT	ADT_Radiated_ V7.6.15.9.5	N/A	N/A	N/A
Turn Table Max-Full	MF-7802BS	N/A	N/A	N/A
Turn Table Controller Max-Full	MF-7802BS	MF780208674	N/A	N/A

Notes:

1. The test was performed in WM - 966 chamber 8.
2. Tested Date: 2024/6/6

4.9 Unwanted Emissions above 1 GHz

Description Manufacturer	Model No.	Serial No.	Calibrated Date	Calibrated Until
Antenna Tower Max-Full	MFT-151SS-0.5T	N/A	N/A	N/A
EMI Test Receiver R&S	ESR3	102782	2021/12/10 2023/12/7	2022/12/9 2024/12/6
Horn Antenna RFSPIN	DRH18-E	210103A18E	2021/11/14 2023/11/12	2022/11/13 2024/11/11
Horn Antenna Schwarzbeck	BBHA 9170	9170-1049	2021/11/14 2023/11/12	2022/11/13 2024/11/11
MXA Signal Analyzer Keysight	N9020B	MY60110513	2021/12/24 2023/12/22	2022/12/23 2024/12/21
Preamplifier EMCI	EMC118A45SE	980808	2021/1/3 2023/12/28	2022/1/2 2024/12/27
	EMC184045SE	980788	2021/1/18 2024/1/15	2022/1/17 2025/1/14
RF Coaxial Cable EMCI	EMC101G-KM-KM-2000	201254	2021/1/18 2024/1/15	2022/1/17 2025/1/14
	EMC101G-KM-KM-3000	201258	2021/1/18 2024/1/15	2022/1/17 2025/1/14
	EMC101G-KM-KM-5000	201261	2021/1/18 2024/1/15	2022/1/17 2025/1/14
	EMC104-SM-SM-1000	210102	2021/1/18 2024/1/15	2022/1/17 2025/1/14
	EMC104-SM-SM-3000	201231	2021/1/18 2024/1/15	2022/1/17 2025/1/14
	EMC104-SM-SM-9000	201243	2021/1/18 2024/1/15	2022/1/17 2025/1/14
Software BV ADT	ADT_Radiated_ V7.6.15.9.5	N/A	N/A	N/A
Turn Table Max-Full	MF-7802BS	N/A	N/A	N/A
Turn Table Controller Max-Full	MF-7802BS	MF780208674	N/A	N/A

Notes:

1. The test was performed in WM - 966 chamber 8.
2. Tested Date: 2021/12/28 ~ 2024/6/4

5 Limits of Test Items

5.1 26 dB Bandwidth

The results are for reference only.

5.2 RF Output Power

Operation Band	EUT Category	Limit
U-NII-1	Outdoor Access Point	1 Watt (30 dBm) (Max. e.i.r.p \leq 125mW(21 dBm) at any elevation angle above 30 degrees as measured from the horizon)
	Fixed point-to-point Access Point	1 Watt (30 dBm)
	Indoor Access Point	1 Watt (30 dBm)
	Mobile and Portable client device	250mW (24 dBm)

Operation Band	Limit
U-NII-2A	250 mW (24 dBm) or 11 dBm+10 log B*
U-NII-2C	250 mW (24 dBm) or 11 dBm+10 log B*
U-NII-3	1 Watt (30 dBm)

*B is the 26 dB emission bandwidth in megahertz

Per KDB 662911 D01 Multiple Transmitter Output Method of conducted output power measurement on IEEE 802.11 devices,

Array Gain = 0 dB (i.e., no array gain) for $N_{ANT} \leq 4$;

Array Gain = 0 dB (i.e., no array gain) for channel widths ≥ 40 MHz for any N_{ANT} ;

Array Gain = $5 \log(N_{ANT}/N_{SS})$ dB or 3 dB, whichever is less, for 20-MHz channel widths with $N_{ANT} \geq 5$.

For power measurements on all other devices: Array Gain = $10 \log(N_{ANT}/N_{SS})$ dB.

5.3 Power Spectral Density

Operation Band	EUT Category	Limit
U-NII-1	Outdoor Access Point	17 dBm/MHz
	Fixed point-to-point Access Point	
	Indoor Access Point	
	Mobile and Portable client device	11 dBm/MHz

Operation Band	Limit
U-NII-2A	11 dBm/MHz
U-NII-2C	11 dBm/MHz
U-NII-3	30 dBm/500 kHz

5.4 6 dB Bandwidth

Within the 5.725-5.850 GHz band, the minimum 6 dB bandwidth of U-NII devices shall be at least 500 kHz.

5.5 Occupied Bandwidth

The results are for reference only.

5.6 Frequency Stability

The frequency of the carrier signal shall be maintained within band of operation.

5.7 AC Power Conducted Emissions

Frequency (MHz)	Conducted Limit (dBuV)	
	Quasi-peak	Average
0.15 - 0.5	66 - 56	56 - 46
0.50 - 5.0	56	46
5.0 - 30.0	60	50

Notes:

1. The lower limit shall apply at the transition frequencies.
2. The limit decreases in line with the logarithm of the frequency in the range of 0.15 to 0.50 MHz.

5.8 Unwanted Emissions below 1 GHz

Radiated emissions which fall in the restricted bands must comply with the radiated emission limits specified as below table.

Frequencies (MHz)	Field Strength (microvolts/meter)	Measurement Distance (meters)
0.009 ~ 0.490	2400/F(kHz)	300
0.490 ~ 1.705	24000/F(kHz)	30
1.705 ~ 30.0	30	30
30 ~ 88	100	3
88 ~ 216	150	3
216 ~ 960	200	3
Above 960	500	3

Notes:

1. The lower limit shall apply at the transition frequencies.
2. Emission level (dBuV/m) = 20 log Emission level (uV/m).

5.9 Unwanted Emissions above 1 GHz

Radiated emissions which fall in the restricted bands must comply with the radiated emission limits specified as below table.

Frequencies (MHz)	Field Strength (microvolts/meter)	Measurement Distance (meters)
Above 960	500	3

Notes:

1. The lower limit shall apply at the transition frequencies.
2. Emission level (dBuV/m) = 20 log Emission level (uV/m).
3. For frequencies above 1000 MHz, the field strength limits are based on average detector, however, the peak field strength of any emission shall not exceed the maximum permitted average limits, specified above by more than 20 dB under any condition of modulation.

Limits of unwanted emission out of the restricted bands

Applicable To	Limit	
789033 D02 General UNII Test Procedure New Rules v02r01	Field Strength at 3 m	
	PK: 74 (dBµV/m)	AV: 54 (dBµV/m)

For transmitters operating in the 5.15-5.25 GHz band:

Applicable To	EIRP Limit	Equivalent Field Strength at 3 m
15.407(b)(1)	PK: -27 (dBm/MHz)	PK: 68.2 (dBµV/m)

For transmitters operating in the 5.25-5.35 GHz band:

Applicable To	EIRP Limit	Equivalent Field Strength at 3 m
15.407(b)(2)	PK: -27 (dBm/MHz)	PK: 68.2 (dBµV/m)

For transmitters operating in the 5.47-5.725 GHz band:

Applicable To	EIRP Limit	Equivalent Field Strength at 3 m
15.407(b)(3)	PK: -27 (dBm/MHz)	PK: 68.2 (dBµV/m)

For transmitters operating in the 5.725-5.850 GHz band:

Applicable To	EIRP Limit	Equivalent Field Strength at 3 m
15.407(b)(4)(i)	PK: -27 (dBm/MHz) ^{*1} PK: 10 (dBm/MHz) ^{*2} PK: 15.6 (dBm/MHz) ^{*3} PK: 27 (dBm/MHz) ^{*4}	PK: 68.2 (dBμV/m) ^{*1} PK: 105.2 (dBμV/m) ^{*2} PK: 110.8 (dBμV/m) ^{*3} PK: 122.2 (dBμV/m) ^{*4}
^{*1} beyond 75 MHz or more above of the band edge. ^{*2} below the band edge increasing linearly to 10 dBm/MHz at 25 MHz above. ^{*3} below the band edge increasing linearly to a level of 15.6 dBm/MHz at 5 MHz above. ^{*4} from 5 MHz above or below the band edge increasing linearly to a level of 27 dBm/MHz at the band edge.		

Note: The following formula is used to convert the equipment isotropic radiated power (eirp) to field strength:

$$E = \frac{1000000 \sqrt{30P}}{3} \mu\text{V/m, where } P \text{ is the eirp (Watts).}$$

6 Test Arrangements

6.1 26 dB Bandwidth

6.1.1 Test Setup

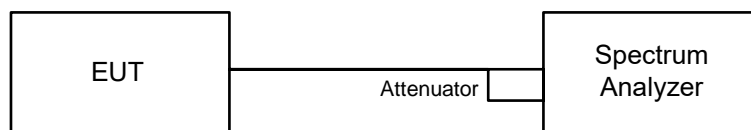

6.1.2 Test Procedure

- Set RBW = approximately 1% of the emission bandwidth.
- Set the VBW > RBW.
- Detector = Peak.
- Trace mode = max hold.
- Measure the maximum width of the emission that is 26 dB down from the peak of the emission. Compare this with the RBW setting of the analyzer. Readjust RBW and repeat measurement as needed until the RBW/EBW ratio is approximately 1%.

6.2 RF Output Power

6.2.1 Test Setup

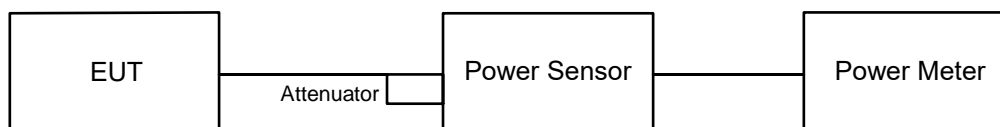

For channel straddling:

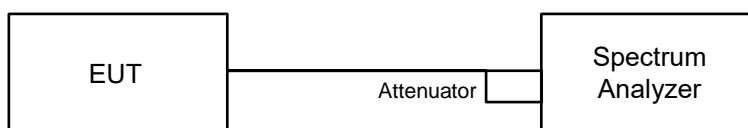

6.2.2 Test Procedure

Method PM is used to perform output power measurement, trigger and gating function of wide band power meter is enabled to measure max output power of TX on burst and set the detector to average. Duty factor is not added to measured value.

For channel straddling:

Method SA-2A

- Set span to encompass the entire emission bandwidth (EBW) of the signal.
- Set RBW = 1 MHz, Set VBW ≥ 3 MHz, Detector = RMS
- Sweep points ≥ $[2 \times \text{span} / \text{RBW}]$. (This gives bin-to-bin spacing ≤ RBW / 2, so that narrowband signals are not lost between frequency bins.)
- Manually set sweep time ≥ $10 \times (\text{number of points in sweep}) \times (\text{total on/off period of the transmitted signal})$.
- Perform a single sweep.
- Record the max value and add $10 \log (1/\text{duty cycle})$.

Note: When measuring straddle channel power, use compute power by integrating the spectrum across the 26 dB EBW or 99% OBW of the signal using the instrument's band power measurement function, with band limits set equal to the EBW or OBW band edges. If the instrument does not have a band power function, then sum the spectrum levels (in power units) at 1 MHz intervals extending across the 26 dB EBW or 99% OBW of the spectrum.

6.3 Power Spectral Density

6.3.1 Test Setup

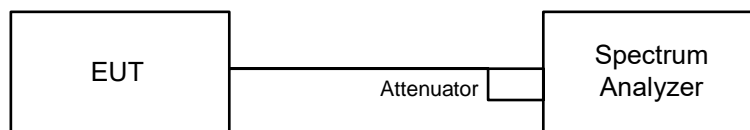

6.3.2 Test Procedure

For specified measurement bandwidth 1 MHz:

Method SA-2

- Set span to encompass the entire emission bandwidth (EBW) of the signal.
- Set RBW = 1 MHz, Set VBW \geq 3 MHz, Detector = RMS
- Sweep points $\geq [2 \times \text{span} / \text{RBW}]$. (This gives bin-to-bin spacing \leq RBW / 2, so that narrowband signals are not lost between frequency bins.)
- Sweep time = auto, trigger set to "free run".
- Trace average at least 100 traces in power averaging mode.
- Use the peak search function on the instrument to find the peak of the spectrum and record its value.
- Record the max value and add 10 log (1/duty cycle).

For specified measurement bandwidth 500 kHz:

Method SA-2

- Set span to encompass the entire emission bandwidth (EBW) of the signal.
- Set RBW = 300 kHz, Set VBW \geq 1 MHz, Detector = RMS
- Scale the observed power level to an equivalent value in 500 kHz by adjusting (increasing) the measured power by a bandwidth correction factor (BWCF) where $\text{BWCF} = 10\log(500 \text{ kHz}/300 \text{ kHz})$
- Sweep points $\geq [2 \times \text{span} / \text{RBW}]$. (This gives bin-to-bin spacing \leq RBW / 2, so that narrowband signals are not lost between frequency bins.)
- Sweep time = auto, trigger set to "free run".
- Trace average at least 100 traces in power averaging mode.
- Use the peak search function on the instrument to find the peak of the spectrum and record its value.
- Record the max value and add 10 log (1/duty cycle).

6.4 6 dB Bandwidth

6.4.1 Test Setup

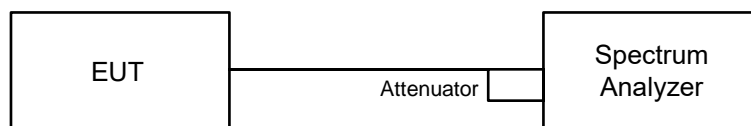

6.4.2 Test Procedure

- Set resolution bandwidth (RBW) = 100 kHz.
- Set the video bandwidth (VBW) \geq 3 x RBW, Detector = Peak.
- Trace mode = max hold.
- Sweep = auto couple.
- Measure the maximum width of the emission that is constrained by the frequencies associated with the two amplitude points (upper and lower) that are attenuated by 6 dB relative to the maximum level measured in the fundamental emission.

6.5 Occupied Bandwidth

6.5.1 Test Setup

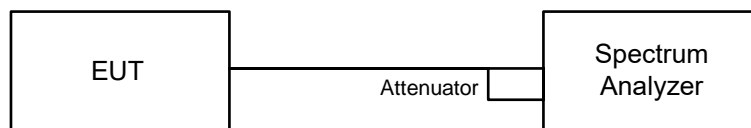

6.5.2 Test Procedure

The transmitter output was connected to the spectrum analyzer through an attenuator. The bandwidth of the fundamental frequency was measured by spectrum analyzer with resolution bandwidth in the range of 1% to 5% of the anticipated emission bandwidth, and a video bandwidth at least 3x the resolution bandwidth and set the detector to Sampling. The width of a frequency band such that, below the lower and above the upper frequency limits, the mean powers emitted are each equal to a specified percentage 0.5% of the total mean power of a given emission.

6.6 Frequency Stability

6.6.1 Test Setup

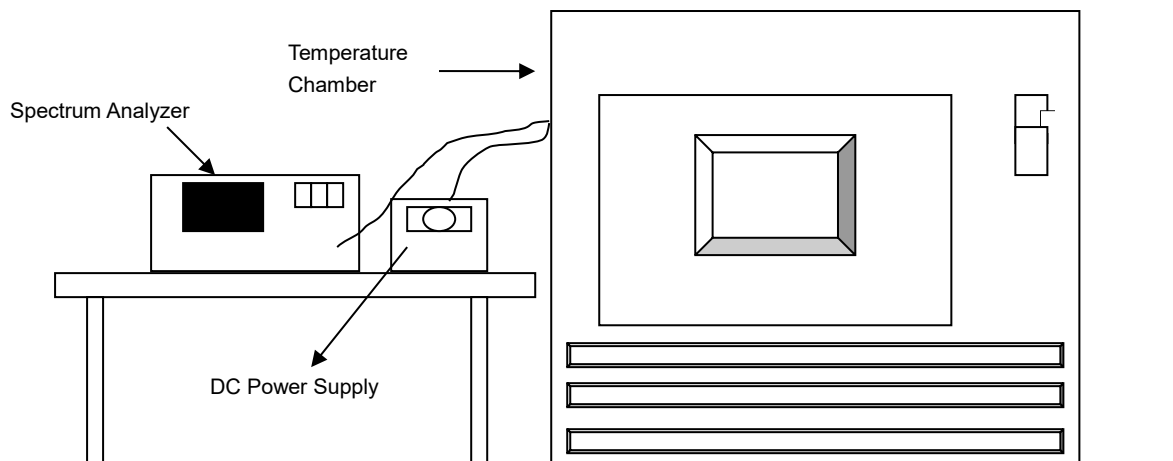

6.6.2 Test Procedure

- The EUT was placed inside the environmental test chamber and powered by nominal DC voltage.
- Turn the EUT on and couple its output to a spectrum analyzer.
- Turn the EUT off and set the chamber to the highest temperature specified.
- Allow sufficient time (approximately 30 min) for the temperature of the chamber to stabilize, turn the EUT on and measure the operating frequency after 2, 5, and 10 Minutes.
- Repeat step (d) with the temperature chamber set to the next desired temperature until measurements down to the lowest specified temperature have been completed.
- The test chamber was allowed to stabilize at +20 degree C for a minimum of 30 Minutes. The supply voltage was then adjusted on the EUT from 85% to 115% and the frequency record.

6.7 AC Power Conducted Emissions

6.7.1 Test Setup

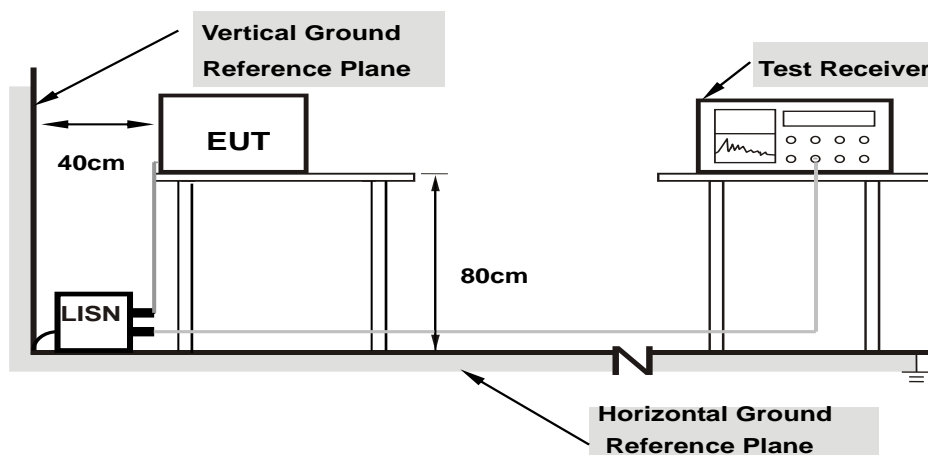

Note: 1.Support units were connected to second LISN.

For the actual test configuration, please refer to the attached file (Test Setup Photo).

6.7.2 Test Procedure

- The EUT was placed on a 0.8 meter to the top of table and placed 0.4 meters from the conducting wall of the shielded room with EUT being connected to the power mains through a line impedance stabilization network (LISN). Other support units were connected to the power mains through another LISN. The two LISNs provide 50 ohm/ 50 uH of coupling impedance for the measuring instrument.
- Both lines of the power mains connected to the EUT were checked for maximum conducted interference.
- The frequency range from 150 kHz to 30 MHz was searched. Emission levels under (Limit – 20 dB) was not recorded.

Note: The resolution bandwidth and video bandwidth of test receiver is 9 kHz for quasi-peak detection (QP) and average detection (AV) at frequency 0.15 MHz-30 MHz.

6.8 Unwanted Emissions below 1 GHz

6.8.1 Test Setup

For Radiated emission below 30 MHz

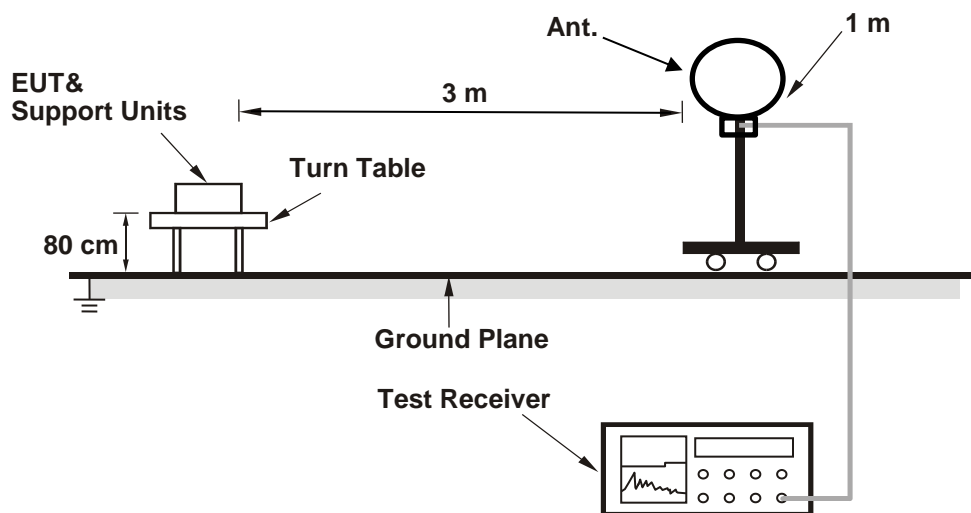

For Radiated emission above 30 MHz

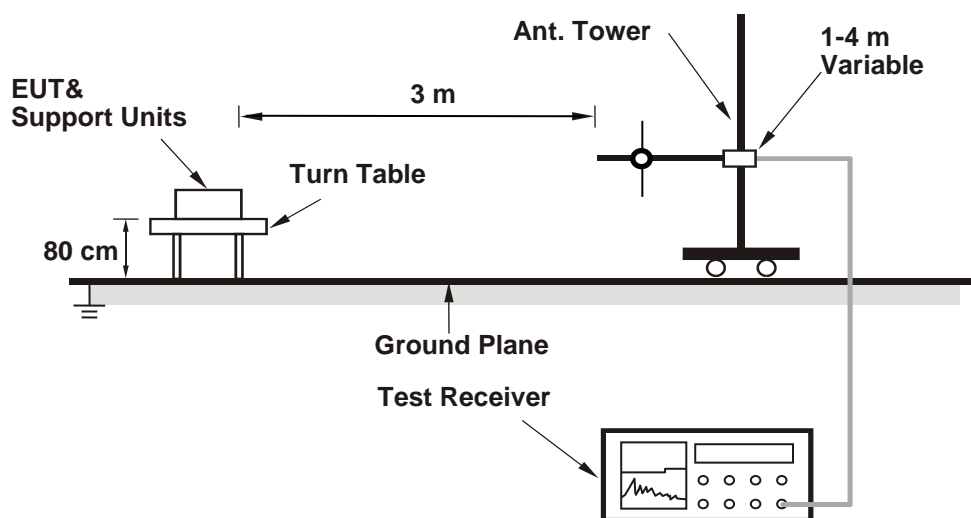

For the actual test configuration, please refer to the attached file (Test Setup Photo).

6.8.2 Test Procedure

For Radiated emission below 30 MHz

- a. The EUT was placed on the top of a rotating table 0.8 meters above the ground at 3 meter chamber room for test. The table was rotated 360 degrees to determine the position of the highest radiation.
- b. The EUT was set 3 meters away from the interference-receiving antenna, which was mounted on the top of a variable-height antenna tower.
- c. Parallel, perpendicular, and ground-parallel orientations of the antenna are set to make the measurement.
- d. For each suspected emission, the EUT was arranged to its worst case and the rotatable table was turned from 0 degrees to 360 degrees to find the maximum reading.
- e. The test-receiver system was set to Quasi-Peak Detect Function and Specified Bandwidth with Maximum Hold Mode, except for the frequency band (9 kHz to 90 kHz and 110 kHz to 490 kHz) set to average detect function and peak detect function.

Notes:

1. The resolution bandwidth and video bandwidth of test receiver/spectrum analyzer is 200 Hz at frequency below 150 kHz.
2. The resolution bandwidth and video bandwidth of test receiver/spectrum analyzer is 9 kHz or 10 kHz at frequency (150 kHz to 30 MHz).
3. All modes of operation were investigated and the worst-case emissions are reported.

For Radiated emission above 30 MHz

- a. The EUT was placed on the top of a rotating table 0.8 meters above the ground at 3 meter chamber room for test. The table was rotated 360 degrees to determine the position of the highest radiation.
- b. The EUT was set 3 meters away from the interference-receiving antenna, which was mounted on the top of a variable-height antenna tower.
- c. The height of antenna is varied from one meter to four meters above the ground to determine the maximum value of the field strength. Both horizontal and vertical polarizations of the antenna are set to make the measurement.
- d. For each suspected emission, the EUT was arranged to its worst case and then the antenna was tuned to heights from 1 meter to 4 meters and the rotatable table was turned from 0 degrees to 360 degrees to find the maximum reading.
- e. The test-receiver system was set to quasi-peak detect function and specified bandwidth with maximum hold mode when the test frequency is below 1 GHz.

Notes:

1. The resolution bandwidth and video bandwidth of test receiver/spectrum analyzer is 120 kHz for Quasi-peak detection (QP) at frequency below 1 GHz.
2. All modes of operation were investigated and the worst-case emissions are reported.

6.9 Unwanted Emissions above 1 GHz

6.9.1 Test Setup

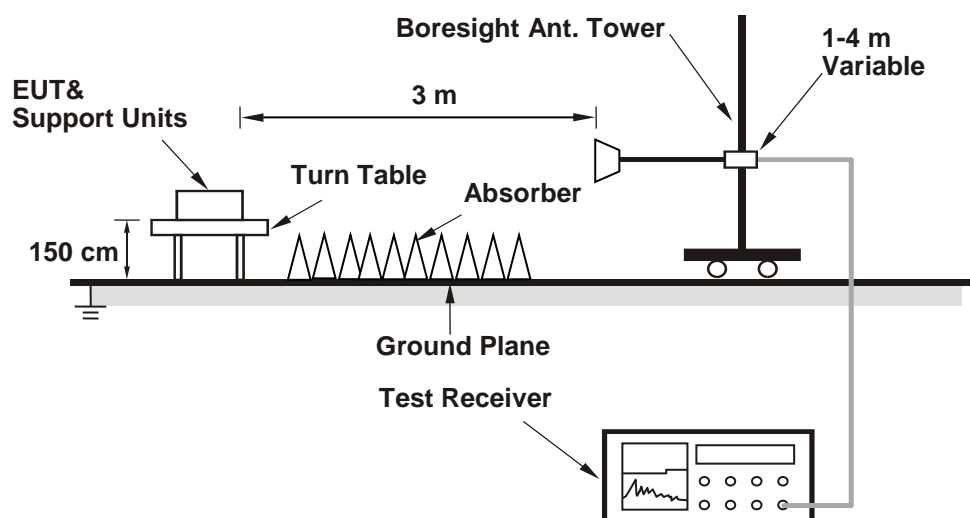

For the actual test configuration, please refer to the attached file (Test Setup Photo).

6.9.2 Test Procedure

- The EUT was placed on the top of a rotating table 1.5 meters above the ground at 3 meter chamber room for test. The table was rotated 360 degrees to determine the position of the highest radiation.
- The EUT was set 3 meters away from the interference-receiving antenna, which was mounted on the top of a variable-height antenna tower.
- The height of antenna is varied from one meter to four meters above the ground to determine the maximum value of the field strength. Both horizontal and vertical polarizations of the antenna are set to make the measurement.
- For each suspected emission, the EUT was arranged to its worst case and then the antenna was tuned to heights from 1 meter to 4 meters and the rotatable table was turned from 0 degrees to 360 degrees to find the maximum reading.
- The test-receiver system was set to peak and average detects function and specified bandwidth with maximum hold mode when the test frequency is above 1 GHz. If the peak reading value also meets average limit, measurement with the average detector is unnecessary.

Notes:

- The resolution bandwidth of test receiver/spectrum analyzer is 1 MHz and the video bandwidth is 3 MHz for Peak detection (PK) and Average detection (AV) at frequency above 1 GHz.
- For fundamental and harmonic signal measurement, the resolution bandwidth of test receiver/spectrum analyzer is 1 MHz and the video bandwidth is $\geq 1/T$ (Duty cycle $< 98\%$) or 10 Hz (Duty cycle $\geq 98\%$) for Average detection (AV) at frequency above 1 GHz.
- All modes of operation were investigated and the worst-case emissions are reported.

7 Test Results of Test Item

7.1 26 dB Bandwidth

Input Power:	54 Vdc	Environmental Conditions:	23°C, 67% RH	Tested By:	Chris Lin
--------------	--------	---------------------------	--------------	------------	-----------

802.11a

Channel	Frequency (MHz)	26 dB Bandwidth (MHz)	
		Chain 0	Chain 1
52	5260	20.48	20.60
60	5300	20.45	20.52
64	5320	20.51	20.46
100	5500	20.63	20.64
116	5580	20.46	20.66
140	5700	20.66	20.71
144 (U-NII-2C)	5720	15.45	15.41
144 (U-NII-3)	5720	5.21	5.05

Determined Output Power Limit			
Channel Number	Freq. (MHz)	Min. B(MHz)	Determined Conducted Power Limit (dBm)
52	5260	20.48	24.11 > 24
60	5300	20.45	24.1 > 24
64	5320	20.46	24.1 > 24
100	5500	20.63	24.14 > 24
116	5580	20.46	24.1 > 24
140	5700	20.66	24.15 > 24
144 (U-NII-2C)	5720	15.41	22.87 < 24

Note: For U-NII-2A, U-NII-2C Band output power limitation is determined based on 26dBc bandwidth.

802.11ax (HE20)

Channel	Frequency (MHz)	26 dB Bandwidth (MHz)	
		Chain 0	Chain 1
52	5260	21.97	21.49
60	5300	21.82	21.23
64	5320	22.02	21.81
100	5500	21.39	22.06
116	5580	21.90	21.41
140	5700	21.87	21.83
144 (U-NII-2C)	5720	16.03	15.68
144 (U-NII-3)	5720	6.08	5.76

Determined Output Power Limit			
Channel Number	Freq. (MHz)	Min. B(MHz)	Determined Conducted Power Limit (dBm)
52	5260	21.49	24.32 > 24
60	5300	21.23	24.26 > 24
64	5320	21.81	24.38 > 24
100	5500	21.39	24.3 > 24
116	5580	21.41	24.3 > 24
140	5700	21.83	24.39 > 24
144 (U-NII-2C)	5720	15.68	22.95 < 24

Note: For U-NII-2A, U-NII-2C Band output power limitation is determined based on 26dBc bandwidth.

802.11ax (HE40)

Channel	Frequency (MHz)	26 dB Bandwidth (MHz)	
		Chain 0	Chain 1
54	5270	41.51	41.34
62	5310	41.95	41.51
102	5510	41.15	41.51
110	5550	41.21	41.38
134	5670	41.56	41.59
142 (U-NII-2C)	5710	35.68	35.82
142 (U-NII-3)	5710	5.63	5.73

Determined Output Power Limit			
Channel Number	Freq. (MHz)	Min. B(MHz)	Determined Conducted Power Limit (dBm)
54	5270	41.34	27.16 > 24
62	5310	41.51	27.18 > 24
102	5510	41.15	27.14 > 24
110	5550	41.21	27.15 > 24
134	5670	41.56	27.18 > 24
142 (U-NII-2C)	5710	35.68	26.52 > 24

Note: For U-NII-2A, U-NII-2C Band output power limitation is determined based on 26dBc bandwidth.

802.11ax (HE80)

Channel	Frequency (MHz)	26 dB Bandwidth (MHz)	
		Chain 0	Chain 1
58	5290	83.22	82.95
106	5530	82.75	83.39
122	5610	83.36	83.10
138 (U-NII-2C)	5690	76.39	76.60
138 (U-NII-3)	5690	6.77	6.49

Determined Output Power Limit			
Channel Number	Freq. (MHz)	Min. B(MHz)	Determined Conducted Power Limit (dBm)
58	5290	82.95	30.18 > 24
106	5530	82.75	30.17 > 24
122	5610	83.10	30.19 > 24
138 (U-NII-2C)	5690	76.39	29.83 > 24

Note: For U-NII-2A, U-NII-2C Band output power limitation is determined based on 26dBc bandwidth.

Spectrum Plot of Minimum Value

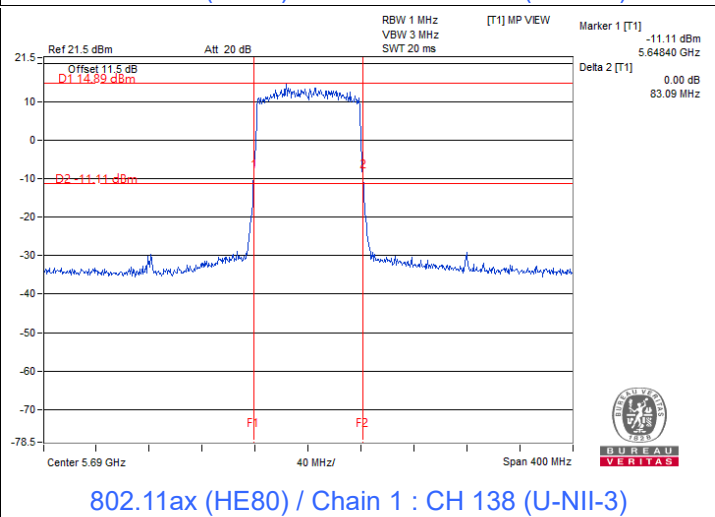
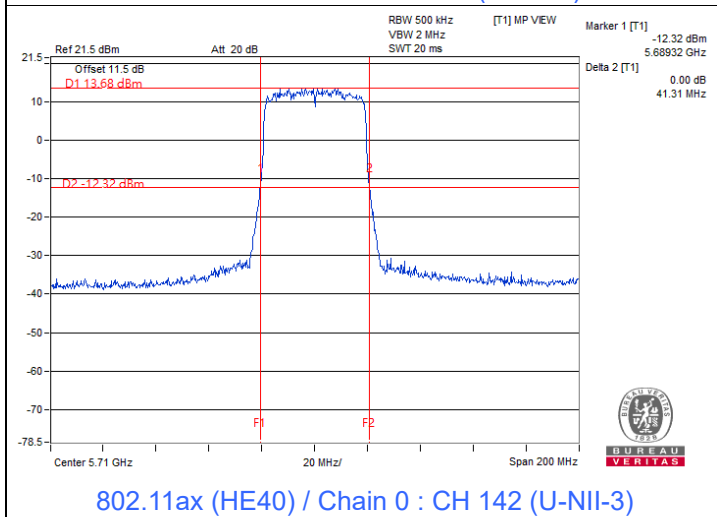
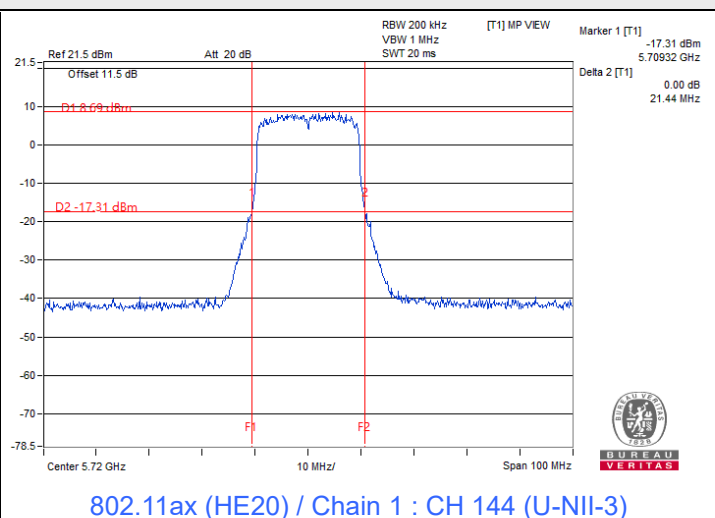
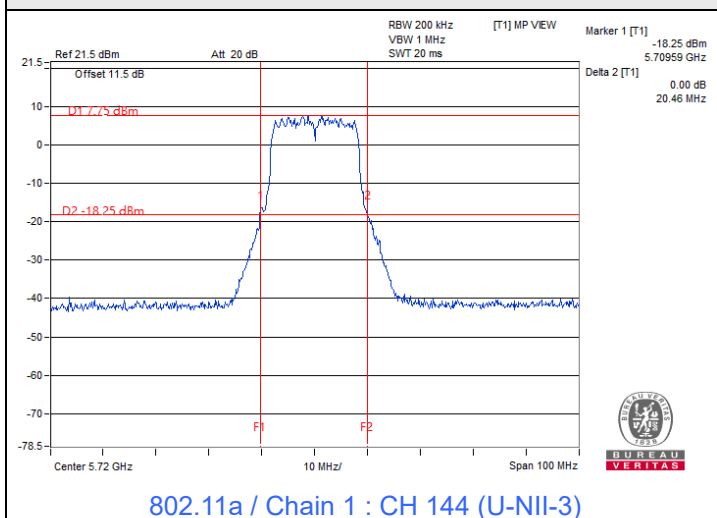

Notes:

1. For U-NII-2C straddle channel = 5725 MHz - Marker 1
2. For U-NII-3 straddle channel = Marker 1 + Delta 2 - 5725 MHz

7.2 RF Output Power

Input Power:	54 Vdc	Environmental Conditions:	23°C, 67% RH	Tested By:	Chris Lin
--------------	--------	---------------------------	--------------	------------	-----------

802.11a

Chan.	Chan. Freq. (MHz)	Average Power (dBm)		Total Power (mW)	Total Power (dBm)	Power Limit (dBm)	Above 30 Deg. Gain (dBi)	EIRP (mW)	EIRP (dBm)	EIRP Limit (dBm)	Test Result
		Chain 0	Chain 1								
36	5180	14.20	14.07	51.83	17.15	29.7	3.46	114.969	20.61	21	Pass
40	5200	14.05	13.95	50.241	17.01	29.7	3.46	111.444	20.47	21	Pass
48	5240	13.77	13.82	47.922	16.81	29.7	3.46	106.3	20.27	21	Pass

Chan.	Chan. Freq. (MHz)	Average Power (dBm)		Total Power (mW)	Total Power (dBm)	Power Limit (dBm)	Test Result
		Chain 0	Chain 1				
52	5260	18.12	17.24	117.83	20.71	23.5	Pass
60	5300	17.25	17.52	109.582	20.40	23.5	Pass
64	5320	17.46	17.31	109.546	20.40	23.5	Pass
100	5500	16.42	16.35	87.005	19.40	22.5	Pass
116	5580	14.40	16.43	71.496	18.54	22.5	Pass
140	5700	16.38	16.28	85.913	19.34	22.5	Pass
*144 (U-NII-2C)	5720	15.99	15.95	83.268	19.20	21.34	Pass
*144 (U-NII-3)	5720	9.56	9.53	18.966	12.78	28.5	Pass
149	5745	25.55	25.26	694.66	28.42	28.5	Pass
157	5785	25.58	25.37	705.76	28.49	28.5	Pass
165	5825	25.45	25.33	691.945	28.40	28.5	Pass

Notes:

- * : Test was performed in accordance with measurement follow FCC KDB 789033 UNII test procedure Method SA-2A and use spectrum analyzer test , the duty factor was included in the total power.
- Directional gain is the maximum gain of antennas.
- For U-NII-1, the maximum gain is 6.3 dBi > 6 dBi, so the output power limit shall be reduced to $30 - (6.3 - 6) = 29.7$ dBm.
- For U-NII-2A, the maximum gain is 6.5 dBi > 6 dBi, so the output power limit shall be reduced to [Determined Conducted Power Limit - (6.5 - 6)].
- For U-NII-2C, the maximum gain is 7.5 dBi > 6 dBi, so the output power limit shall be reduced to [Determined Conducted Power Limit - (7.5 - 6)].
- For U-NII-3, the maximum gain is 7.5 dBi > 6 dBi, so the output power limit shall be reduced to $30 - (7.5 - 6) = 28.5$ dBm.
- For U-NII-1, the gain of above 30 degrees from the horizon is 3.46 dBi, EIRP (dBm) = Average Power (dBm) + 3.46 dBi

802.11ac (VHT20)

Chan.	Chan. Freq. (MHz)	Average Power (dBm)		Total Power (mW)	Total Power (dBm)	Power Limit (dBm)	Above 30 Deg. Gain (dBi)	EIRP (mW)	EIRP (dBm)	EIRP Limit (dBm)	Test Result
		Chain 0	Chain 1								
36	5180	14.08	13.90	50.133	17.00	29.7	3.46	111.205	20.46	21	Pass
40	5200	13.90	14.08	50.133	17.00	29.7	3.46	111.205	20.46	21	Pass
48	5240	14.03	13.97	50.239	17.01	29.7	3.46	111.44	20.47	21	Pass

Chan.	Chan. Freq. (MHz)	Average Power (dBm)		Total Power (mW)	Total Power (dBm)	Power Limit (dBm)	Test Result
		Chain 0	Chain 1				
52	5260	17.20	17.19	104.841	20.21	23.5	Pass
60	5300	17.31	17.14	105.588	20.24	23.5	Pass
64	5320	17.35	17.18	106.565	20.28	23.5	Pass
100	5500	16.65	16.78	93.881	19.73	22.5	Pass
116	5580	16.88	16.83	96.948	19.87	22.5	Pass
140	5700	16.82	16.81	96.057	19.83	22.5	Pass
*144 (U-NII-2C)	5720	15.71	15.68	79.197	18.99	21.45	Pass
*144 (U-NII-3)	5720	10.28	10.24	22.657	13.55	28.5	Pass
149	5745	25.65	25.01	684.239	28.35	28.5	Pass
157	5785	25.72	25.15	700.591	28.45	28.5	Pass
165	5825	25.62	25.07	686.12	28.36	28.5	Pass

Notes:

- * : Test was performed in accordance with measurement follow FCC KDB 789033 UNII test procedure Method SA-2A and use spectrum analyzer test , the duty factor was included in the total power.
- Directional gain is the maximum gain of antennas.
- For U-NII-1, the maximum gain is 6.3 dBi > 6 dBi, so the output power limit shall be reduced to $30 - (6.3 - 6) = 29.7$ dBm.
- For U-NII-2A, the maximum gain is 6.5 dBi > 6 dBi, so the output power limit shall be reduced to [Determined Conducted Power Limit - (6.5 - 6)].
- For U-NII-2C, the maximum gain is 7.5 dBi > 6 dBi, so the output power limit shall be reduced to [Determined Conducted Power Limit - (7.5 - 6)].
- For U-NII-3, the maximum gain is 7.5 dBi > 6 dBi, so the output power limit shall be reduced to $30 - (7.5 - 6) = 28.5$ dBm.
- For U-NII-1, the gain of above 30 degrees from the horizon is 3.46 dBi, EIRP (dBm) = Average Power (dBm) + 3.46 dBi

802.11ac (VHT40)

Chan.	Chan. Freq. (MHz)	Average Power (dBm)		Total Power (mW)	Total Power (dBm)	Power Limit (dBm)	Above 30 Deg. Gain (dBi)	EIRP (mW)	EIRP (dBm)	EIRP Limit (dBm)	Test Result
		Chain 0	Chain 1								
38	5190	13.95	13.97	49.777	16.97	29.7	3.46	110.415	20.43	21	Pass
46	5230	14.30	14.11	52.679	17.22	29.7	3.46	116.852	20.68	21	Pass

Chan.	Chan. Freq. (MHz)	Average Power (dBm)		Total Power (mW)	Total Power (dBm)	Power Limit (dBm)	Test Result
		Chain 0	Chain 1				
54	5270	20.24	20.20	210.395	23.23	23.5	Pass
62	5310	19.92	20.19	202.647	23.07	23.5	Pass
102	5510	18.78	18.52	146.631	21.66	22.5	Pass
110	5550	18.84	18.81	152.592	21.84	22.5	Pass
134	5670	18.45	19.12	151.642	21.81	22.5	Pass
*142 (U-NII-2C)	5710	18.60	18.57	153.32	21.86	22.5	Pass
*142 (U-NII-3)	5710	9.26	9.24	17.869	12.52	28.5	Pass
151	5755	25.37	25.18	673.96	28.29	28.5	Pass
159	5795	25.37	25.29	682.415	28.34	28.5	Pass

Notes:

- * : Test was performed in accordance with measurement follow FCC KDB 789033 UNII test procedure Method SA-2A and use spectrum analyzer test , the duty factor was included in the total power.
- Directional gain is the maximum gain of antennas.
- For U-NII-1, the maximum gain is 6.3 dBi > 6 dBi, so the output power limit shall be reduced to $30 - (6.3 - 6) = 29.7$ dBm.
- For U-NII-2A, the maximum gain is 6.5 dBi > 6 dBi, so the output power limit shall be reduced to [Determined Conducted Power Limit - (6.5 - 6)].
- For U-NII-2C, the maximum gain is 7.5 dBi > 6 dBi, so the output power limit shall be reduced to [Determined Conducted Power Limit - (7.5 - 6)].
- For U-NII-3, the maximum gain is 7.5 dBi > 6 dBi, so the output power limit shall be reduced to $30 - (7.5 - 6) = 28.5$ dBm.
- For U-NII-1, the gain of above 30 degrees from the horizon is 3.46 dBi, EIRP (dBm) = Average Power (dBm) + 3.46 dBi

802.11ac (VHT80)

Chan.	Chan. Freq. (MHz)	Average Power (dBm)		Total Power (mW)	Total Power (dBm)	Power Limit (dBm)	Above 30 Deg. Gain (dBi)	EIRP (mW)	EIRP (dBm)	EIRP Limit (dBm)	Test Result
		Chain 0	Chain 1								
42	5210	14.05	13.92	50.07	17.00	29.7	3.46	111.065	20.46	21	Pass

Chan.	Chan. Freq. (MHz)	Average Power (dBm)		Total Power (mW)	Total Power (dBm)	Power Limit (dBm)	Test Result
		Chain 0	Chain 1				
58	5290	18.38	18.48	139.335	21.44	23.5	Pass
106	5530	18.31	18.30	135.372	21.32	22.5	Pass
122	5610	18.52	18.66	144.573	21.60	22.5	Pass
*138 (U-NII-2C)	5690	18.57	18.65	153.778	21.87	22.5	Pass
*138 (U-NII-3)	5690	5.43	5.39	7.36	8.67	28.5	Pass
155	5775	23.18	23.20	416.899	26.20	28.5	Pass

Notes:

- * : Test was performed in accordance with measurement follow FCC KDB 789033 UNII test procedure Method SA-2A and use spectrum analyzer test , the duty factor was included in the total power.
- Directional gain is the maximum gain of antennas.
- For U-NII-1, the maximum gain is 6.3 dBi > 6 dBi, so the output power limit shall be reduced to $30 - (6.3 - 6) = 29.7$ dBm.
- For U-NII-2A, the maximum gain is 6.5 dBi > 6 dBi, so the output power limit shall be reduced to [Determined Conducted Power Limit - (6.5 - 6)].
- For U-NII-2C, the maximum gain is 7.5 dBi > 6 dBi, so the output power limit shall be reduced to [Determined Conducted Power Limit - (7.5 - 6)].
- For U-NII-3, the maximum gain is 7.5 dBi > 6 dBi, so the output power limit shall be reduced to $30 - (7.5 - 6) = 28.5$ dBm.
- For U-NII-1, the gain of above 30 degrees from the horizon is 3.46 dBi, EIRP (dBm) = Average Power (dBm) + 3.46 dBi

802.11ax (HE20)

Chan.	Chan. Freq. (MHz)	Average Power (dBm)		Total Power (mW)	Total Power (dBm)	Power Limit (dBm)	Above 30 Deg. Gain (dBi)	EIRP (mW)	EIRP (dBm)	EIRP Limit (dBm)	Test Result
		Chain 0	Chain 1								
36	5180	14.10	13.95	50.535	17.04	29.7	3.46	112.097	20.5	21	Pass
40	5200	13.95	14.10	50.535	17.04	29.7	3.46	112.097	20.5	21	Pass
48	5240	14.06	14.01	50.645	17.05	29.7	3.46	112.341	20.51	21	Pass

Chan.	Chan. Freq. (MHz)	Average Power (dBm)		Total Power (mW)	Total Power (dBm)	Power Limit (dBm)	Test Result
		Chain 0	Chain 1				
52	5260	17.33	17.28	107.532	20.32	23.5	Pass
60	5300	17.40	17.21	107.556	20.32	23.5	Pass
64	5320	17.42	17.24	108.174	20.34	23.5	Pass
100	5500	17.01	16.89	99.099	19.96	22.5	Pass
116	5580	16.98	16.92	99.092	19.96	22.5	Pass
140	5700	16.97	16.92	98.978	19.96	22.5	Pass
*144 (U-NII-2C)	5720	15.78	15.74	80.391	19.05	21.45	Pass
*144 (U-NII-3)	5720	10.33	10.31	22.972	13.61	28.5	Pass
149	5745	25.68	25.06	690.455	28.39	28.5	Pass
157	5785	25.76	25.19	707.073	28.49	28.5	Pass
165	5825	25.64	25.11	690.777	28.39	28.5	Pass

Notes:

- * : Test was performed in accordance with measurement follow FCC KDB 789033 UNII test procedure Method SA-2A and use spectrum analyzer test , the duty factor was included in the total power.
- Directional gain is the maximum gain of antennas.
- For U-NII-1, the maximum gain is 6.3 dBi > 6 dBi, so the output power limit shall be reduced to $30 - (6.3 - 6) = 29.7$ dBm.
- For U-NII-2A, the maximum gain is 6.5 dBi > 6 dBi, so the output power limit shall be reduced to [Determined Conducted Power Limit - (6.5 - 6)].
- For U-NII-2C, the maximum gain is 7.5 dBi > 6 dBi, so the output power limit shall be reduced to [Determined Conducted Power Limit - (7.5 - 6)].
- For U-NII-3, the maximum gain is 7.5 dBi > 6 dBi, so the output power limit shall be reduced to $30 - (7.5 - 6) = 28.5$ dBm.
- For U-NII-1, the gain of above 30 degrees from the horizon is 3.46 dBi, EIRP (dBm) = Average Power (dBm) + 3.46 dBi

802.11ax (HE40)

Chan.	Chan. Freq. (MHz)	Average Power (dBm)		Total Power (mW)	Total Power (dBm)	Power Limit (dBm)	Above 30 Deg. Gain (dBi)	EIRP (mW)	EIRP (dBm)	EIRP Limit (dBm)	Test Result
		Chain 0	Chain 1								
38	5190	13.98	14.15	51.005	17.08	29.7	3.46	113.139	20.54	21	Pass
46	5230	14.32	14.11	52.803	17.23	29.7	3.46	117.127	20.69	21	Pass

Chan.	Chan. Freq. (MHz)	Average Power (dBm)		Total Power (mW)	Total Power (dBm)	Power Limit (dBm)	Test Result
		Chain 0	Chain 1				
54	5270	20.38	20.41	219.045	23.41	23.5	Pass
62	5310	20.01	20.37	209.124	23.20	23.5	Pass
102	5510	18.84	18.59	148.837	21.73	22.5	Pass
110	5550	18.96	18.88	155.973	21.93	22.5	Pass
134	5670	18.52	19.19	154.106	21.88	22.5	Pass
*142 (U-NII-2C)	5710	18.67	18.66	156.169	21.94	22.5	Pass
*142 (U-NII-3)	5710	9.32	9.33	18.18	12.60	28.5	Pass
151	5755	25.41	25.22	680.196	28.33	28.5	Pass
159	5795	25.43	25.34	691.12	28.40	28.5	Pass

Notes:

- * : Test was performed in accordance with measurement follow FCC KDB 789033 UNII test procedure Method SA-2A and use spectrum analyzer test , the duty factor was included in the total power.
- Directional gain is the maximum gain of antennas.
- For U-NII-1, the maximum gain is 6.3 dBi > 6 dBi, so the output power limit shall be reduced to $30 - (6.3 - 6) = 29.7$ dBm.
- For U-NII-2A, the maximum gain is 6.5 dBi > 6 dBi, so the output power limit shall be reduced to [Determined Conducted Power Limit - (6.5 - 6)].
- For U-NII-2C, the maximum gain is 7.5 dBi > 6 dBi, so the output power limit shall be reduced to [Determined Conducted Power Limit - (7.5 - 6)].
- For U-NII-3, the maximum gain is 7.5 dBi > 6 dBi, so the output power limit shall be reduced to $30 - (7.5 - 6) = 28.5$ dBm.
- For U-NII-1, the gain of above 30 degrees from the horizon is 3.46 dBi, EIRP (dBm) = Average Power (dBm) + 3.46 dBi

802.11ax (HE80)

Chan.	Chan. Freq. (MHz)	Average Power (dBm)		Total Power (mW)	Total Power (dBm)	Power Limit (dBm)	Above 30 Deg. Gain (dBi)	EIRP (mW)	EIRP (dBm)	EIRP Limit (dBm)	Test Result
		Chain 0	Chain 1								
42	5210	14.10	13.95	50.535	17.04	29.7	3.46	112.097	20.5	21	Pass

Chan.	Chan. Freq. (MHz)	Average Power (dBm)		Total Power (mW)	Total Power (dBm)	Power Limit (dBm)	Test Result
		Chain 0	Chain 1				
58	5290	18.42	18.52	140.624	21.48	23.5	Pass
106	5530	18.45	18.41	139.327	21.44	22.5	Pass
122	5610	18.59	18.75	147.266	21.68	22.5	Pass
*138 (U-NII-2C)	5690	18.66	18.73	156.816	21.95	22.5	Pass
*138 (U-NII-3)	5690	5.48	5.43	7.437	8.71	28.5	Pass
155	5775	23.22	23.23	420.272	26.24	28.5	Pass

Notes:

- * : Test was performed in accordance with measurement follow FCC KDB 789033 UNII test procedure Method SA-2A and use spectrum analyzer test , the duty factor was included in the total power.
- Directional gain is the maximum gain of antennas.
- For U-NII-1, the maximum gain is 6.3 dBi > 6 dBi, so the output power limit shall be reduced to $30 - (6.3 - 6) = 29.7$ dBm.
- For U-NII-2A, the maximum gain is 6.5 dBi > 6 dBi, so the output power limit shall be reduced to [Determined Conducted Power Limit - (6.5 - 6)].
- For U-NII-2C, the maximum gain is 7.5 dBi > 6 dBi, so the output power limit shall be reduced to [Determined Conducted Power Limit - (7.5 - 6)].
- For U-NII-3, the maximum gain is 7.5 dBi > 6 dBi, so the output power limit shall be reduced to $30 - (7.5 - 6) = 28.5$ dBm.
- For U-NII-1, the gain of above 30 degrees from the horizon is 3.46 dBi, EIRP (dBm) = Average Power (dBm) + 3.46 dBi

802.11ac (VHT20) Beamforming

Chan.	Chan. Freq. (MHz)	Average Power (dBm)		Total Power (mW)	Total Power (dBm)	Power Limit (dBm)	Above 30 Deg. Gain (dBi)	EIRP (mW)	EIRP (dBm)	EIRP Limit (dBm)	Test Result
		Chain 0	Chain 1								
36	5180	11.88	11.67	30.106	14.79	27.13	5.56	108.306	20.35	21	Pass
40	5200	11.72	11.89	30.312	14.82	27.13	5.56	109.047	20.38	21	Pass
48	5240	11.79	11.74	30.029	14.78	27.13	5.56	108.029	20.34	21	Pass

Chan.	Chan. Freq. (MHz)	Average Power (dBm)		Total Power (mW)	Total Power (dBm)	Power Limit (dBm)	Test Result
		Chain 0	Chain 1				
52	5260	17.20	17.19	104.841	20.21	20.83	Pass
60	5300	17.31	17.14	105.588	20.24	20.83	Pass
64	5320	17.35	17.18	106.565	20.28	20.83	Pass
100	5500	16.42	16.25	86.023	19.35	19.78	Pass
116	5580	16.32	16.34	85.908	19.34	19.78	Pass
140	5700	16.34	16.32	85.908	19.34	19.78	Pass
*144 (U-NII-2C)	5720	15.22	15.18	70.666	18.49	18.73	Pass
*144 (U-NII-3)	5720	9.71	9.68	19.893	12.99	25.78	Pass
149	5745	22.91	22.21	361.775	25.58	25.78	Pass
157	5785	22.86	22.21	359.538	25.56	25.78	Pass
165	5825	22.82	22.21	357.767	25.54	25.78	Pass

Notes:

- * : Test was performed in accordance with measurement follow FCC KDB 789033 UNII test procedure Method SA-2A and use spectrum analyzer test , the duty factor was included in the total power.
- Directional gain = $10 \log[(10^{\text{Chain0}/20} + 10^{\text{Chain1}/20})^2 / 2]$
- For U-NII-1, the directional gain is 8.87 dBi > 6 dBi, so the output power limit shall be reduced to $30-(8.87-6) = 27.13$ dBm.
- For U-NII-2A, the directional gain is 9.17 dBi > 6 dBi, so the output power limit shall be reduced to [Determined Conducted Power Limit-(9.17-6)].
- For U-NII-2C, the directional gain is 10.22 dBi > 6 dBi, so the output power limit shall be reduced to [Determined Conducted Power Limit-(10.22-6)].
- For U-NII-3, the directional gain is 10.22 dBi > 6 dBi, so the output power limit shall be reduced to $30-(10.22-6) = 25.78$ dBm.
- For U-NII-1, the gain of above 30 degrees from the horizon is 5.56 dBi, EIRP (dBm) = Average Power (dBm) + 5.56 dBi

802.11ac (VHT40) Beamforming

Chan.	Chan. Freq. (MHz)	Average Power (dBm)		Total Power (mW)	Total Power (dBm)	Power Limit (dBm)	Above 30 Deg. Gain (dBi)	EIRP (mW)	EIRP (dBm)	EIRP Limit (dBm)	Test Result
		Chain 0	Chain 1								
38	5190	11.81	11.98	30.947	14.91	27.13	5.56	111.332	20.47	21	Pass
46	5230	12.13	11.90	31.819	15.03	27.13	5.56	114.469	20.59	21	Pass

Chan.	Chan. Freq. (MHz)	Average Power (dBm)		Total Power (mW)	Total Power (dBm)	Power Limit (dBm)	Test Result
		Chain 0	Chain 1				
54	5270	17.21	17.25	105.69	20.24	20.83	Pass
62	5310	17.30	17.70	112.588	20.51	20.83	Pass
102	5510	16.21	15.95	81.138	19.09	19.78	Pass
110	5550	16.27	16.15	83.574	19.22	19.78	Pass
134	5670	15.97	16.60	85.245	19.31	19.78	Pass
*142 (U-NII-2C)	5710	16.10	16.13	86.816	19.39	19.78	Pass
*142 (U-NII-3)	5710	6.12	6.09	8.662	9.38	25.78	Pass
151	5755	22.61	22.41	356.57	25.52	25.78	Pass
159	5795	22.56	22.41	354.482	25.50	25.78	Pass

Notes:

- * : Test was performed in accordance with measurement follow FCC KDB 789033 UNII test procedure Method SA-2A and use spectrum analyzer test , the duty factor was included in the total power.
- Directional gain = $10 \log[(10^{\text{Chain0}/20} + 10^{\text{Chain1}/20})^2 / 2]$
- For U-NII-1, the directional gain is 8.87 dBi > 6 dBi, so the output power limit shall be reduced to $30 - (8.87 - 6) = 27.13$ dBm.
- For U-NII-2A, the directional gain is 9.17 dBi > 6 dBi, so the output power limit shall be reduced to [Determined Conducted Power Limit - (9.17 - 6)].
- For U-NII-2C, the directional gain is 10.22 dBi > 6 dBi, so the output power limit shall be reduced to [Determined Conducted Power Limit - (10.22 - 6)].
- For U-NII-3, the directional gain is 10.22 dBi > 6 dBi, so the output power limit shall be reduced to $30 - (10.22 - 6) = 25.78$ dBm.
- For U-NII-1, the gain of above 30 degrees from the horizon is 5.56 dBi, EIRP (dBm) = Average Power (dBm) + 5.56 dBi

802.11ac (VHT80) Beamforming

Chan.	Chan. Freq. (MHz)	Average Power (dBm)		Total Power (mW)	Total Power (dBm)	Power Limit (dBm)	Above 30 Deg. Gain (dBi)	EIRP (mW)	EIRP (dBm)	EIRP Limit (dBm)	Test Result
		Chain 0	Chain 1								
42	5210	11.91	11.75	30.486	14.84	27.13	5.56	109.673	20.4	21	Pass

Chan.	Chan. Freq. (MHz)	Average Power (dBm)		Total Power (mW)	Total Power (dBm)	Power Limit (dBm)	Test Result
		Chain 0	Chain 1				
58	5290	17.23	17.27	106.178	20.26	20.83	Pass
106	5530	16.31	16.23	84.732	19.28	19.78	Pass
122	5610	16.42	16.52	88.728	19.48	19.78	Pass
*138 (U-NII-2C)	5690	16.11	16.02	85.585	19.32	19.78	Pass
*138 (U-NII-3)	5690	2.31	3.35	4.092	6.12	25.78	Pass
155	5775	22.12	22.20	328.888	25.17	25.78	Pass

Notes:

- * : Test was performed in accordance with measurement follow FCC KDB 789033 UNII test procedure Method SA-2A and use spectrum analyzer test , the duty factor was included in the total power.
- Directional gain = $10 \log[(10^{\text{Chain0}/20} + 10^{\text{Chain1}/20})^2 / 2]$
- For U-NII-1, the directional gain is 8.87 dBi > 6 dBi, so the output power limit shall be reduced to $30-(8.87-6) = 27.13$ dBm.
- For U-NII-2A, the directional gain is 9.17 dBi > 6 dBi, so the output power limit shall be reduced to [Determined Conducted Power Limit-(9.17-6)].
- For U-NII-2C, the directional gain is 10.22 dBi > 6 dBi, so the output power limit shall be reduced to [Determined Conducted Power Limit-(10.22-6)].
- For U-NII-3, the directional gain is 10.22 dBi > 6 dBi, so the output power limit shall be reduced to $30-(10.22-6) = 25.78$ dBm.
- For U-NII-1, the gain of above 30 degrees from the horizon is 5.56 dBi, EIRP (dBm) = Average Power (dBm) + 5.56 dBi

802.11ax (HE20) Beamforming

Chan.	Chan. Freq. (MHz)	Average Power (dBm)		Total Power (mW)	Total Power (dBm)	Power Limit (dBm)	Above 30 Deg. Gain (dBi)	EIRP (mW)	EIRP (dBm)	EIRP Limit (dBm)	Test Result
		Chain 0	Chain 1								
36	5180	11.93	11.77	30.627	14.86	27.13	5.56	110.18	20.42	21	Pass
40	5200	11.76	11.97	30.737	14.88	27.13	5.56	110.576	20.44	21	Pass
48	5240	11.86	11.86	30.692	14.87	27.13	5.56	110.414	20.43	21	Pass

Chan.	Chan. Freq. (MHz)	Average Power (dBm)		Total Power (mW)	Total Power (dBm)	Power Limit (dBm)	Test Result
		Chain 0	Chain 1				
52	5260	17.33	17.28	107.532	20.32	20.83	Pass
60	5300	17.40	17.21	107.556	20.32	20.83	Pass
64	5320	17.42	17.24	108.174	20.34	20.83	Pass
100	5500	16.51	16.39	88.323	19.46	19.78	Pass
116	5580	16.48	16.42	88.316	19.46	19.78	Pass
140	5700	16.47	16.42	88.214	19.46	19.78	Pass
*144 (U-NII-2C)	5720	15.21	15.18	70.584	18.49	18.73	Pass
*144 (U-NII-3)	5720	9.85	9.79	20.475	13.11	25.78	Pass
149	5745	22.91	22.21	361.775	25.58	25.78	Pass
157	5785	22.86	22.21	359.538	25.56	25.78	Pass
165	5825	22.82	22.21	357.767	25.54	25.78	Pass

Notes:

- * : Test was performed in accordance with measurement follow FCC KDB 789033 UNII test procedure Method SA-2A and use spectrum analyzer test , the duty factor was included in the total power.
- Directional gain = $10 \log[(10^{\text{Chain0}/20} + 10^{\text{Chain1}/20})^2 / 2]$
- For U-NII-1, the directional gain is 8.87 dBi > 6 dBi, so the output power limit shall be reduced to $30-(8.87-6) = 27.13$ dBm.
- For U-NII-2A, the directional gain is 9.17 dBi > 6 dBi, so the output power limit shall be reduced to [Determined Conducted Power Limit-(9.17-6)].
- For U-NII-2C, the directional gain is 10.22 dBi > 6 dBi, so the output power limit shall be reduced to [Determined Conducted Power Limit-(10.22-6)].
- For U-NII-3, the directional gain is 10.22 dBi > 6 dBi, so the output power limit shall be reduced to $30-(10.22-6) = 25.78$ dBm.
- For U-NII-1, the gain of above 30 degrees from the horizon is 5.56 dBi, EIRP (dBm) = Average Power (dBm) + 5.56 dBi

802.11ax (HE40) Beamforming

Chan.	Chan. Freq. (MHz)	Average Power (dBm)		Total Power (mW)	Total Power (dBm)	Power Limit (dBm)	Above 30 Deg. Gain (dBi)	EIRP (mW)	EIRP (dBm)	EIRP Limit (dBm)	Test Result
		Chain 0	Chain 1								
38	5190	11.83	12.03	31.199	14.94	27.13	5.56	112.238	20.5	21	Pass
46	5230	12.18	11.95	32.187	15.08	27.13	5.56	115.793	20.64	21	Pass

Chan.	Chan. Freq. (MHz)	Average Power (dBm)		Total Power (mW)	Total Power (dBm)	Power Limit (dBm)	Test Result
		Chain 0	Chain 1				
54	5270	17.31	17.47	109.674	20.40	20.83	Pass
62	5310	17.40	17.81	115.349	20.62	20.83	Pass
102	5510	16.30	16.03	82.745	19.18	19.58	Pass
110	5550	16.35	16.24	85.225	19.31	19.78	Pass
134	5670	16.06	16.70	87.138	19.40	19.78	Pass
*142 (U-NII-2C)	5710	16.27	16.25	89.763	19.53	19.78	Pass
*142 (U-NII-3)	5710	6.28	6.26	8.997	9.54	25.78	Pass
151	5755	22.73	22.53	366.56	25.64	25.78	Pass
159	5795	22.67	22.53	363.987	25.61	25.78	Pass

Notes:

- * : Test was performed in accordance with measurement follow FCC KDB 789033 UNII test procedure Method SA-2A and use spectrum analyzer test , the duty factor was included in the total power.
- Directional gain = $10 \log[(10^{\text{Chain0}/20} + 10^{\text{Chain1}/20})^2 / 2]$
- For U-NII-1, the directional gain is 8.87 dBi > 6 dBi, so the output power limit shall be reduced to $30 - (8.87 - 6) = 27.13$ dBm.
- For U-NII-2A, the directional gain is 9.17 dBi > 6 dBi, so the output power limit shall be reduced to [Determined Conducted Power Limit - (9.17 - 6)].
- For U-NII-2C, the directional gain is 10.22 dBi > 6 dBi, so the output power limit shall be reduced to [Determined Conducted Power Limit - (10.22 - 6)].
- For U-NII-3, the directional gain is 10.22 dBi > 6 dBi, so the output power limit shall be reduced to $30 - (10.22 - 6) = 25.78$ dBm.
- For U-NII-1, the gain of above 30 degrees from the horizon is 5.56 dBi, EIRP (dBm) = Average Power (dBm) + 5.56 dBi

802.11ax (HE80) Beamforming

Chan.	Chan. Freq. (MHz)	Average Power (dBm)		Total Power (mW)	Total Power (dBm)	Power Limit (dBm)	Above 30 Deg. Gain (dBi)	EIRP (mW)	EIRP (dBm)	EIRP Limit (dBm)	Test Result
		Chain 0	Chain 1								
42	5210	11.92	11.79	30.66	14.87	27.13	5.56	110.299	20.43	21	Pass

Chan.	Chan. Freq. (MHz)	Average Power (dBm)		Total Power (mW)	Total Power (dBm)	Power Limit (dBm)	Test Result
		Chain 0	Chain 1				
58	5290	17.37	17.48	110.552	20.44	20.83	Pass
106	5530	16.41	16.35	86.904	19.39	19.78	Pass
122	5610	16.51	16.54	89.853	19.54	19.78	Pass
*138 (U-NII-2C)	5690	16.21	16.15	87.879	19.44	19.78	Pass
*138 (U-NII-3)	5690	2.42	3.41	4.171	6.20	25.78	Pass
155	5775	22.12	22.20	328.888	25.17	25.78	Pass

Notes:

- * : Test was performed in accordance with measurement follow FCC KDB 789033 UNII test procedure Method SA-2A and use spectrum analyzer test , the duty factor was included in the total power.
- Directional gain = $10 \log[(10^{\text{Chain0}/20} + 10^{\text{Chain1}/20})^2 / 2]$
- For U-NII-1, the directional gain is 8.87 dBi > 6 dBi, so the output power limit shall be reduced to $30 - (8.87 - 6) = 27.13$ dBm.
- For U-NII-2A, the directional gain is 9.17 dBi > 6 dBi, so the output power limit shall be reduced to [Determined Conducted Power Limit - (9.17 - 6)].
- For U-NII-2C, the directional gain is 10.22 dBi > 6 dBi, so the output power limit shall be reduced to [Determined Conducted Power Limit - (10.22 - 6)].
- For U-NII-3, the directional gain is 10.22 dBi > 6 dBi, so the output power limit shall be reduced to $30 - (10.22 - 6) = 25.78$ dBm.
- For U-NII-1, the gain of above 30 degrees from the horizon is 5.56 dBi, EIRP (dBm) = Average Power (dBm) + 5.56 dBi

Spectrum Plot for channel straddling

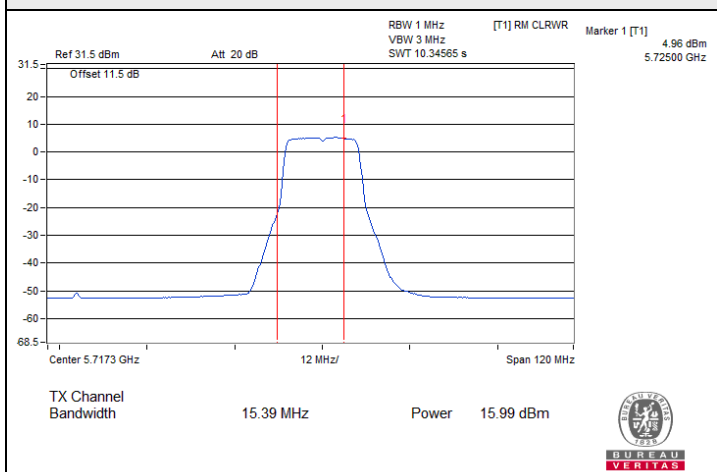

802.11a / Chain 0 : CH 144 (U-NII-2C)

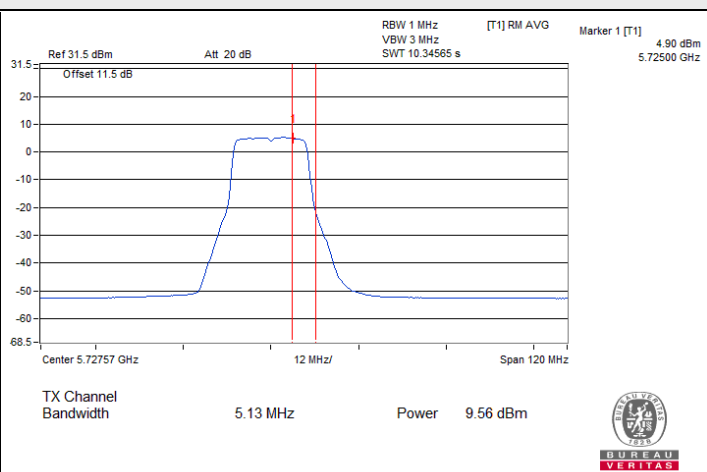

802.11a / Chain 0 : CH 144 (U-NII-3)

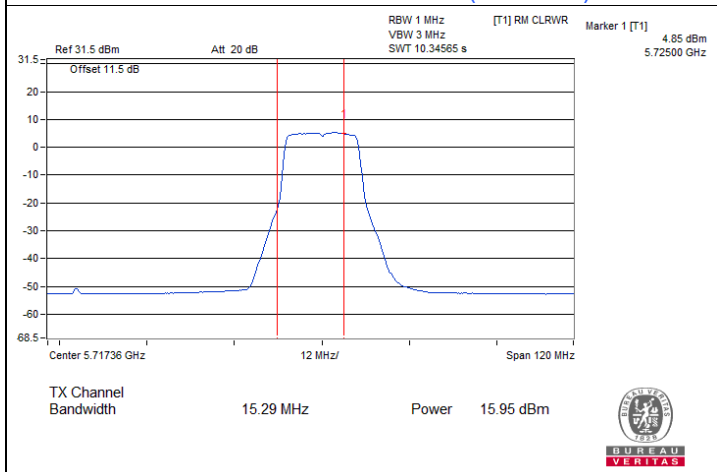

802.11a / Chain 1 : CH 144 (U-NII-2C)

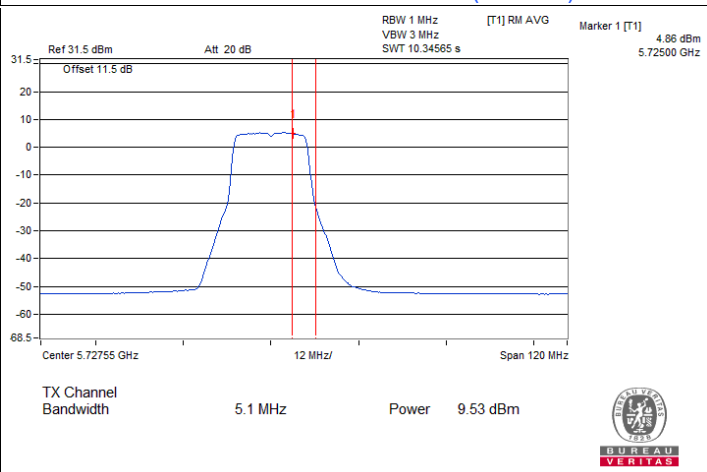

802.11a / Chain 1 : CH 144 (U-NII-3)

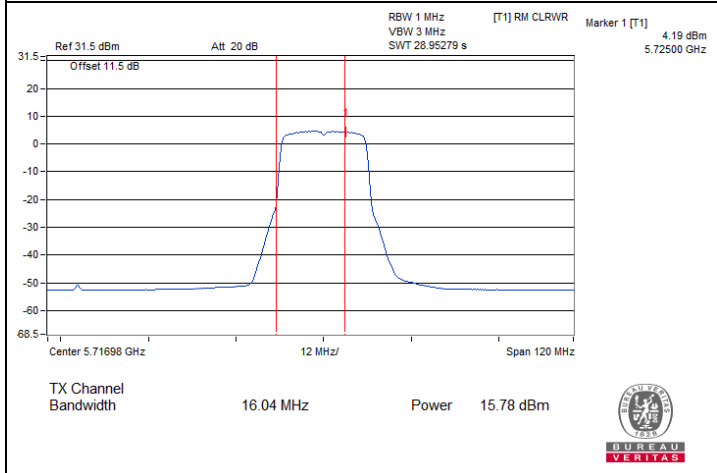

802.11ax (HE20) / Chain 0 : CH 144 (U-NII-2C)

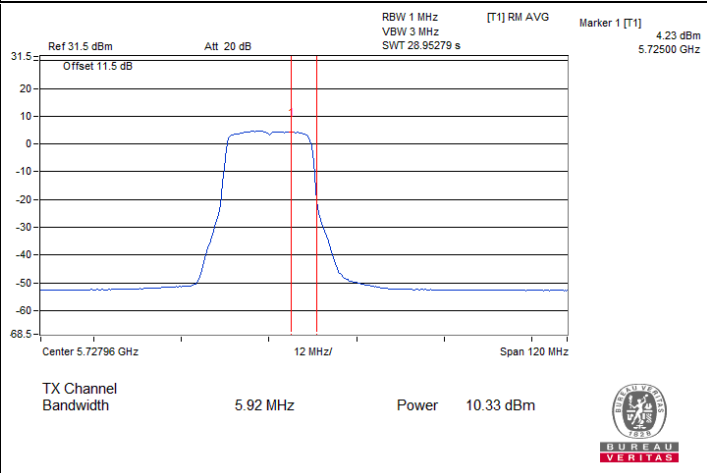

802.11ax (HE20) / Chain 0 : CH 144 (U-NII-3)

Spectrum Plot for channel straddling

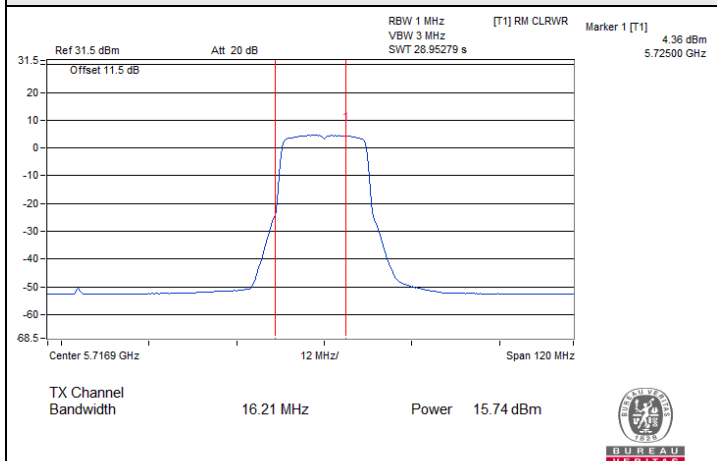

802.11ax (HE20) / Chain 1 : CH 144 (U-NII-2C)

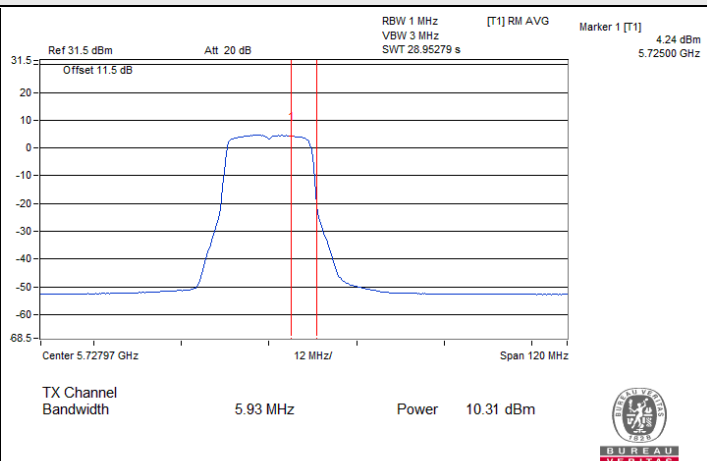

802.11ax (HE20) / Chain 1 : CH 144 (U-NII-3)

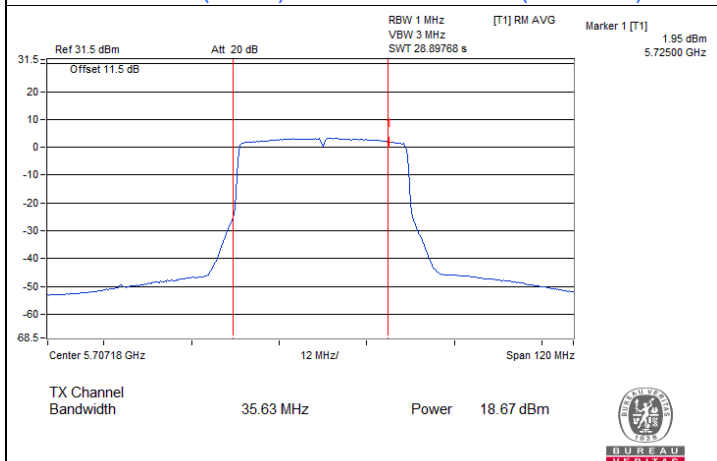

802.11ax (HE40) / Chain 0 : CH 142 (U-NII-2C)

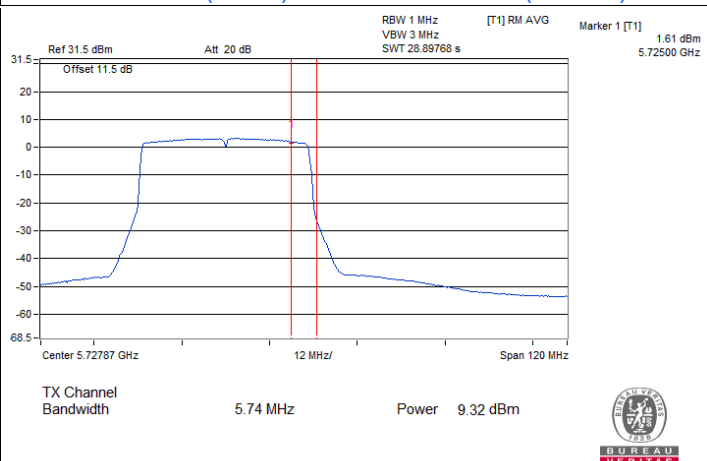

802.11ax (HE40) / Chain 0 : CH 142 (U-NII-3)

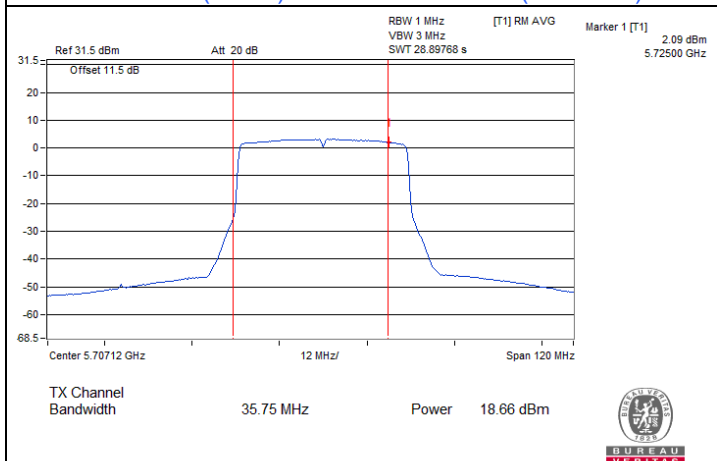

802.11ax (HE40) / Chain 1 : CH 142 (U-NII-2C)

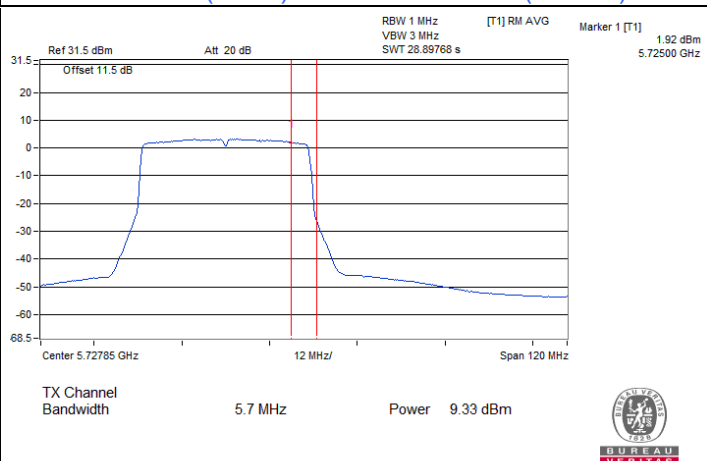

802.11ax (HE40) / Chain 1 : CH 142 (U-NII-3)



Spectrum Plot for channel straddling

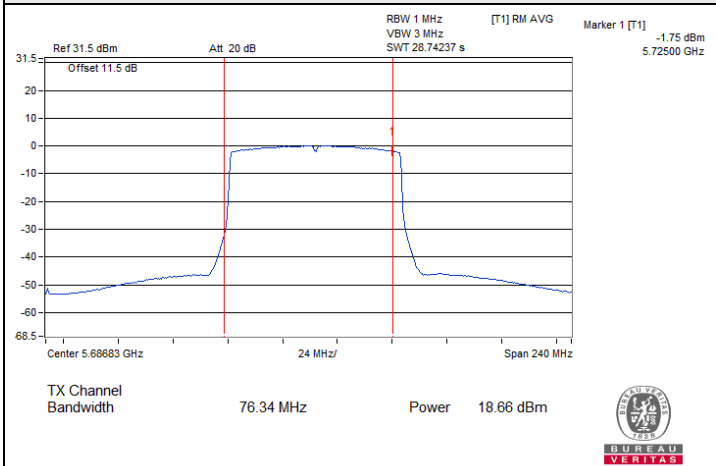

802.11ax (HE80) / Chain 0 : CH 138 (U-NII-2C)

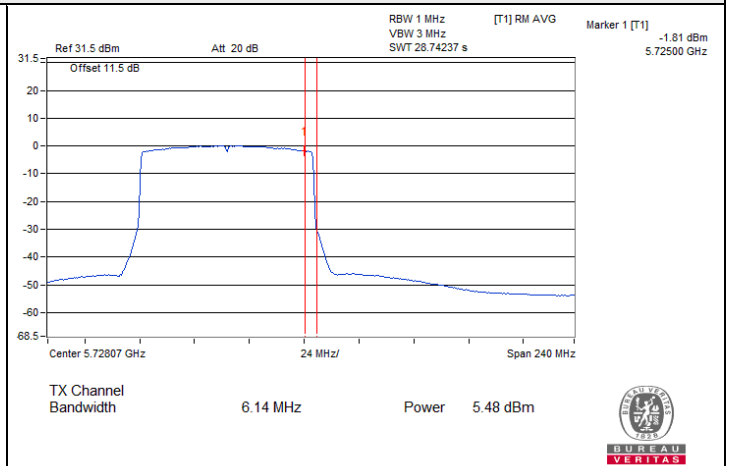

802.11ax (HE80) / Chain 0 : CH 138 (U-NII-3)

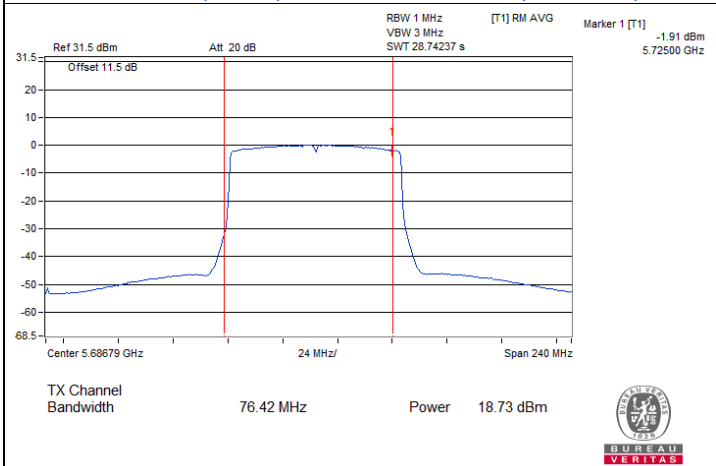

802.11ax (HE80) / Chain 1 : CH 138 (U-NII-2C)

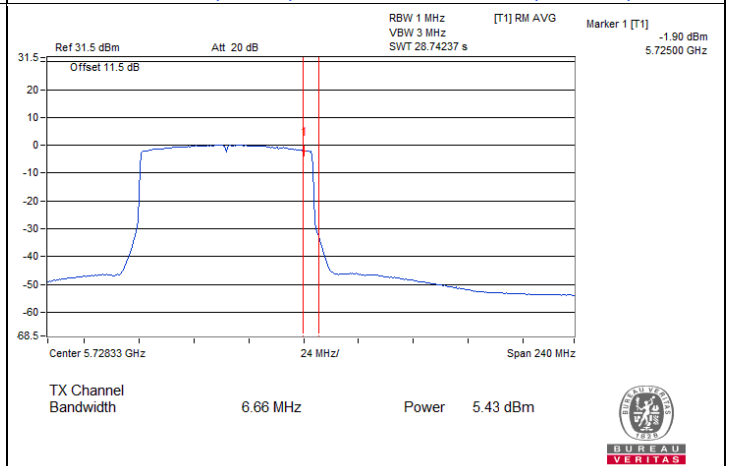

802.11ax (HE80) / Chain 1 : CH 138 (U-NII-3)

7.3 Power Spectral Density

Input Power:	54 Vdc	Environmental Conditions:	23°C, 67% RH	Tested By:	Chris Lin
--------------	--------	---------------------------	--------------	------------	-----------

802.11a

Chan.	Chan. Freq. (MHz)	PSD w/o Duty Factor (dBm/MHz)		Duty Factor (dB)	Total PSD (dBm/MHz)	Max. PSD Limit (dBm/MHz)	Test Result
		Chain 0	Chain 1				
36	5180	1.21	0.50	0.22	4.10	14.13	Pass
40	5200	1.03	0.74	0.22	4.12	14.13	Pass
48	5240	0.83	0.86	0.22	4.08	14.13	Pass
52	5260	4.18	4.67	0.22	7.66	7.83	Pass
60	5300	4.51	4.54	0.22	7.76	7.83	Pass
64	5320	4.34	4.51	0.22	7.66	7.83	Pass
100	5500	3.13	3.18	0.22	6.39	6.78	Pass
116	5580	3.18	3.16	0.22	6.40	6.78	Pass
140	5700	2.94	3.09	0.22	6.25	6.78	Pass
144 (U-NII-2C)	5720	3.20	3.31	0.22	6.49	6.78	Pass

Notes:

- Method E) 2) a) of power density measurement of KDB 662911 is using for calculating total power density. Total power density is summing entire spectra across corresponding frequency bins on the various outputs by computer.
- Directional gain = $10 \log[(10\text{Chain0}/20 + 10\text{Chain1}/20)^2 / 2]$
- For U-NII-1, the directional gain is 8.87 dBi > 6dBi, so the power density limit shall be reduced to $17-(8.87-6) = 14.13$ dBm/MHz.
- For U-NII-2A, the directional gain is 9.17 dBi > 6 dBi, so the power density limit shall be reduced to $11-(9.17-6) = 7.83$ dBm/MHz.
- For U-NII-2C, the directional gain is 10.22 dBi > 6 dBi, so the power density limit shall be reduced to $11-(10.22-6) = 6.78$ dBm/MHz.

802.11ax (HE20)

Chan.	Chan. Freq. (MHz)	PSD w/o Duty Factor (dBm/MHz)		Duty Factor (dB)	Total PSD (dBm/MHz)	Max. PSD Limit (dBm/MHz)	Test Result
		Chain 0	Chain 1				
36	5180	0.80	0.82	0.28	4.10	14.13	Pass
40	5200	0.42	0.96	0.28	3.99	14.13	Pass
48	5240	0.79	0.70	0.28	4.04	14.13	Pass
52	5260	4.37	4.50	0.28	7.73	7.83	Pass
60	5300	4.44	4.19	0.28	7.61	7.83	Pass
64	5320	4.37	4.41	0.28	7.68	7.83	Pass
100	5500	2.97	3.11	0.28	6.33	6.78	Pass
116	5580	3.13	3.11	0.28	6.41	6.78	Pass
140	5700	3.23	3.22	0.28	6.52	6.78	Pass
144 (U-NII-2C)	5720	3.20	3.23	0.28	6.51	6.78	Pass

Notes:

- Method E) 2) a) of power density measurement of KDB 662911 is using for calculating total power density. Total power density is summing entire spectra across corresponding frequency bins on the various outputs by computer.
- Directional gain = $10 \log[(10^{\text{Chain0}/20} + 10^{\text{Chain1}/20})^2 / 2]$
- For U-NII-1, the directional gain is 8.87 dBi > 6dBi, so the power density limit shall be reduced to $17-(8.87-6) = 14.13$ dBm/MHz.
- For U-NII-2A, the directional gain is 9.17 dBi > 6 dBi, so the power density limit shall be reduced to $11-(9.17-6) = 7.83$ dBm/MHz.
- For U-NII-2C, the directional gain is 10.22 dBi > 6 dBi, so the power density limit shall be reduced to $11-(10.22-6) = 6.78$ dBm/MHz.

802.11ax (HE40)

Chan.	Chan. Freq. (MHz)	PSD w/o Duty Factor (dBm/MHz)		Duty Factor (dB)	Total PSD (dBm/MHz)	Max. PSD Limit (dBm/MHz)	Test Result
		Chain 0	Chain 1				
38	5190	-3.17	-3.23	0.26	0.07	14.13	Pass
46	5230	-2.89	-3.07	0.26	0.29	14.13	Pass
54	5270	3.73	3.82	0.26	7.05	7.83	Pass
62	5310	3.66	3.57	0.26	6.89	7.83	Pass
102	5510	3.10	3.02	0.26	6.33	6.78	Pass
110	5550	3.15	2.92	0.26	6.31	6.78	Pass
134	5670	3.06	3.24	0.26	6.42	6.78	Pass
142 (U-NII-2C)	5710	3.12	3.07	0.26	6.37	6.78	Pass

Notes:

- Method E) 2) a) of power density measurement of KDB 662911 is using for calculating total power density. Total power density is summing entire spectra across corresponding frequency bins on the various outputs by computer.
- Directional gain = $10 \log[(10^{\text{Chain0}/20} + 10^{\text{Chain1}/20})^2 / 2]$
- For U-NII-1, the directional gain is 8.87 dBi > 6dBi, so the power density limit shall be reduced to $17-(8.87-6) = 14.13$ dBm/MHz.
- For U-NII-2A, the directional gain is 9.17 dBi > 6 dBi, so the power density limit shall be reduced to $11-(9.17-6) = 7.83$ dBm/MHz.
- For U-NII-2C, the directional gain is 10.22 dBi > 6 dBi, so the power density limit shall be reduced to $11-(10.22-6) = 6.78$ dBm/MHz.

802.11ax (HE80)

Chan.	Chan. Freq. (MHz)	PSD w/o Duty Factor (dBm/MHz)		Duty Factor (dB)	Total PSD (dBm/MHz)	Max. PSD Limit (dBm/MHz)	Test Result
		Chain 0	Chain 1				
42	5210	-5.42	-5.57	0.25	-2.23	14.13	Pass
58	5290	-1.22	-1.17	0.25	2.07	7.83	Pass
106	5530	-0.38	-0.88	0.25	2.64	6.78	Pass
122	5610	0.00	0.00	0.25	3.26	6.78	Pass
138 (U-NII-2C)	5690	0.72	0.47	0.25	3.86	6.78	Pass

Notes:

- Method E) 2) a) of power density measurement of KDB 662911 is using for calculating total power density. Total power density is summing entire spectra across corresponding frequency bins on the various outputs by computer.
- Directional gain = $10 \log[(10^{\text{Chain0}/20} + 10^{\text{Chain1}/20})^2 / 2]$
- For U-NII-1, the directional gain is 8.87 dBi > 6dBi, so the power density limit shall be reduced to $17-(8.87-6) = 14.13$ dBm/MHz.
- For U-NII-2A, the directional gain is 9.17 dBi > 6 dBi, so the power density limit shall be reduced to $11-(9.17-6) = 7.83$ dBm/MHz.
- For U-NII-2C, the directional gain is 10.22 dBi > 6 dBi, so the power density limit shall be reduced to $11-(10.22-6) = 6.78$ dBm/MHz.

802.11a

Chan.	Chan. Freq. (MHz)	PSD w/o Duty Factor (dBm/300kHz)		Total PSD w/o Duty Factor (dBm/300kHz)	Duty Factor (dB)	Total PSD (dBm/500kHz)	PSD Limit (dBm/500kHz)	Test Result
		Chain 0	Chain 1					
144 (U-NII-3)	5720	-5.90	-6.03	-2.95	0.22	-0.51	25.78	Pass
149	5745	3.94	3.95	6.96	0.22	9.40	25.78	Pass
157	5785	3.85	3.87	6.87	0.22	9.31	25.78	Pass
165	5825	3.76	3.81	6.8	0.22	9.24	25.78	Pass

- Notes:
- Method E) 2) b) Measure and sum spectral maxima across the outputs of KDB 662911 is using for calculating total power density.
 - Directional gain = $10 \log[(10^{\text{Chain0}/20} + 10^{\text{Chain1}/20})^2 / 2]$
 - For U-NII-3, the directional gain is 10.22 dBi > 6 dBi, so the power density limit shall be reduced to $30 - (10.22 - 6) = 25.78$ dBm/500kHz.

802.11ax (HE20)

Chan.	Chan. Freq. (MHz)	PSD w/o Duty Factor (dBm/300kHz)		Total PSD w/o Duty Factor (dBm/300kHz)	Duty Factor (dB)	Total PSD (dBm/500kHz)	PSD Limit (dBm/500kHz)	Test Result
		Chain 0	Chain 1					
144 (U-NII-3)	5720	-6.16	-6.24	-3.19	0.28	-0.69	25.78	Pass
149	5745	2.59	2.41	5.51	0.28	8.01	25.78	Pass
157	5785	2.42	2.35	5.4	0.28	7.90	25.78	Pass
165	5825	2.39	2.25	5.33	0.28	7.83	25.78	Pass

- Notes:
- Method E) 2) b) Measure and sum spectral maxima across the outputs of KDB 662911 is using for calculating total power density.
 - Directional gain = $10 \log[(10^{\text{Chain0}/20} + 10^{\text{Chain1}/20})^2 / 2]$
 - For U-NII-3, the directional gain is 10.22 dBi > 6 dBi, so the power density limit shall be reduced to $30 - (10.22 - 6) = 25.78$ dBm/500kHz.

802.11ax (HE40)

Chan.	Chan. Freq. (MHz)	PSD w/o Duty Factor (dBm/300kHz)		Total PSD w/o Duty Factor (dBm/300kHz)	Duty Factor (dB)	Total PSD (dBm/500kHz)	PSD Limit (dBm/500kHz)	Test Result
		Chain 0	Chain 1					
142 (U-NII-3)	5710	-7.10	-7.06	-4.07	0.26	-1.59	25.78	Pass
151	5755	-0.42	-0.42	2.59	0.26	5.07	25.78	Pass
159	5795	-0.52	-0.48	2.51	0.26	4.99	25.78	Pass

- Notes:
- Method E) 2) b) Measure and sum spectral maxima across the outputs of KDB 662911 is using for calculating total power density.
 - Directional gain = $10 \log[(10^{\text{Chain0}/20} + 10^{\text{Chain1}/20})^2 / 2]$
 - For U-NII-3, the directional gain is 10.22 dBi > 6 dBi, so the power density limit shall be reduced to $30 - (10.22 - 6) = 25.78$ dBm/500kHz.



802.11ax (HE80)

Chan.	Chan. Freq. (MHz)	PSD w/o Duty Factor (dBm/300kHz)		Total PSD w/o Duty Factor (dBm/300kHz)	Duty Factor (dB)	Total PSD (dBm/500kHz)	PSD Limit (dBm/500kHz)	Test Result
		Chain 0	Chain 1					
138 (U-NII-3)	5690	-10.57	-10.42	-7.48	0.25	-5.01	25.78	Pass
155	5775	-6.25	-6.07	-3.15	0.25	-0.68	25.78	Pass

- Notes:
- Method E) 2) b) Measure and sum spectral maxima across the outputs of KDB 662911 is using for calculating total power density.
 - Directional gain = $10 \log[(10^{\text{Chain0}/20} + 10^{\text{Chain1}/20})^2 / 2]$
 - For U-NII-3, the directional gain is 10.22 dBi > 6 dBi, so the power density limit shall be reduced to $30 - (10.22 - 6) = 25.78$ dBm/500kHz.

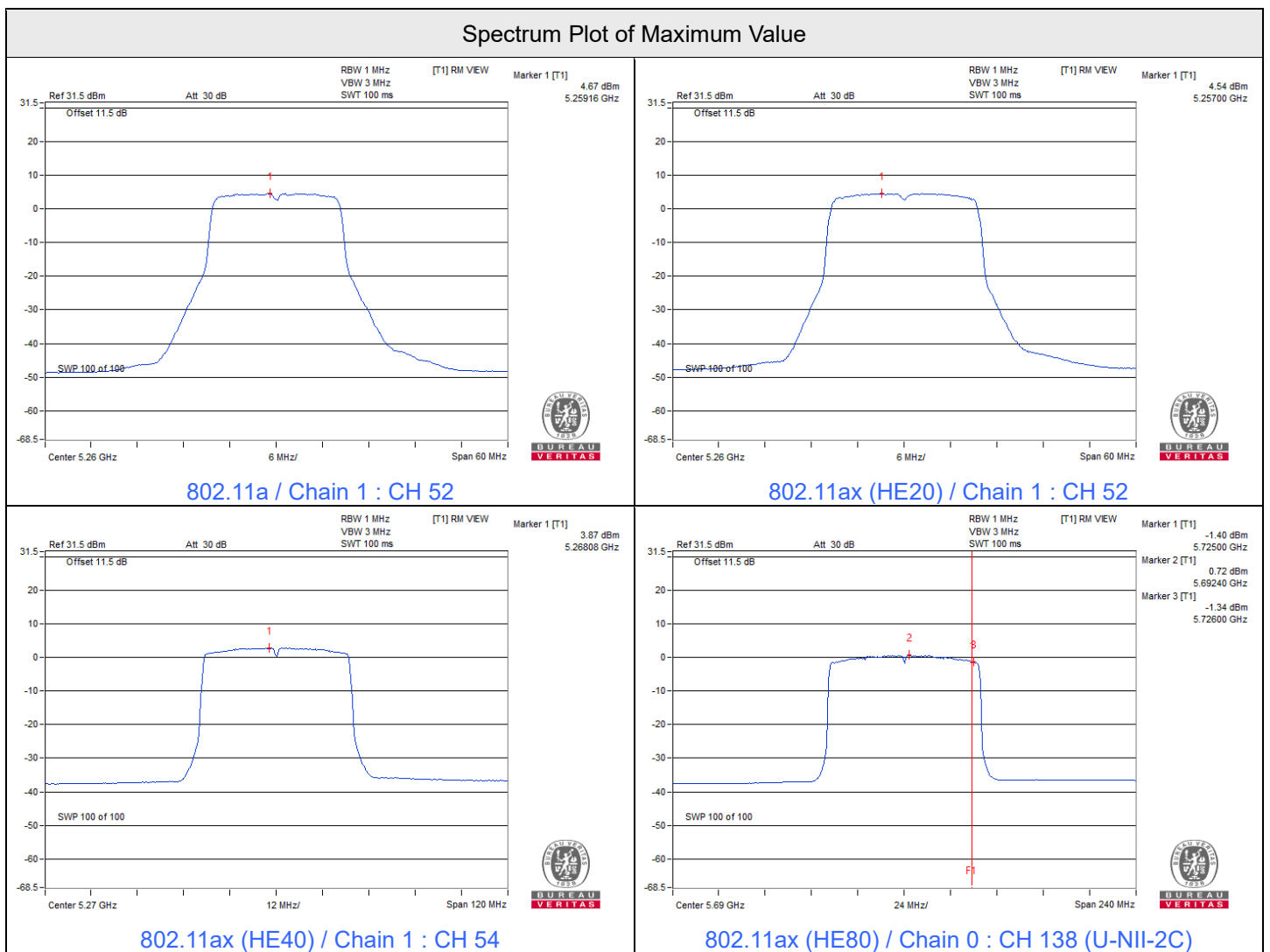



Spectrum Plot of Maximum Value

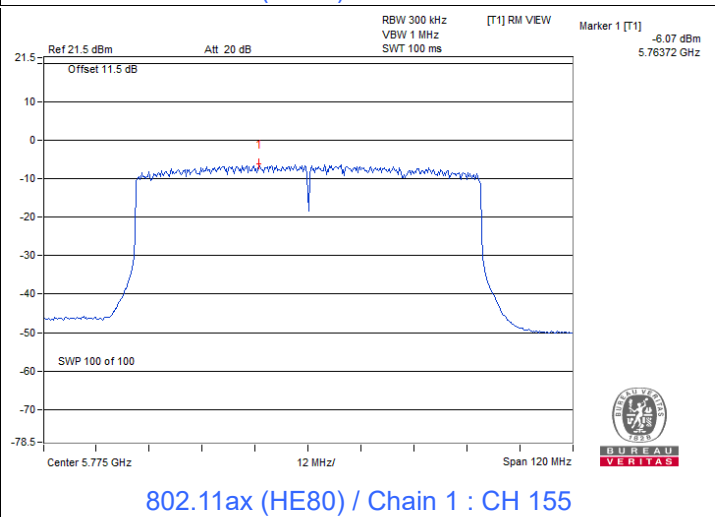
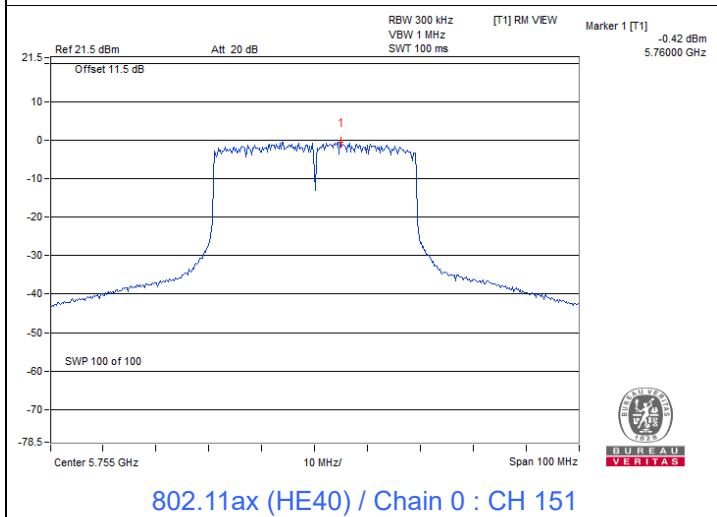
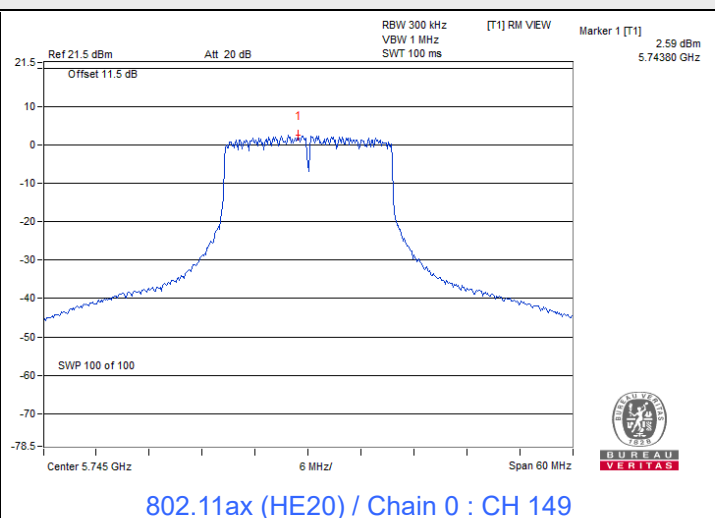
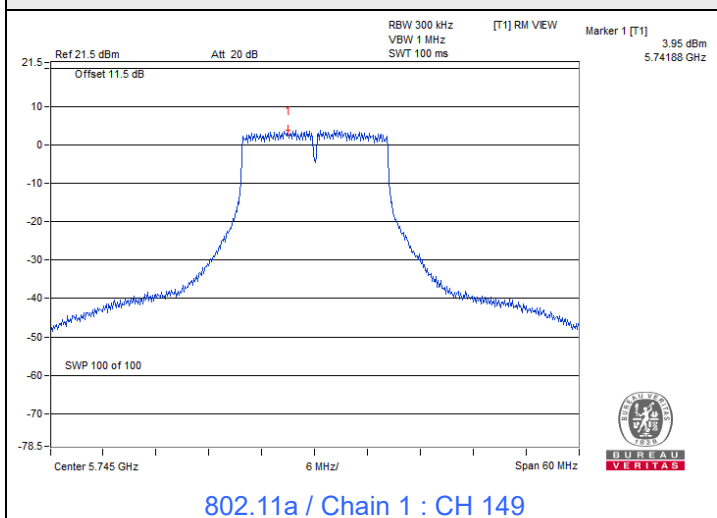

7.4 6 dB Bandwidth

Input Power:	54 Vdc	Environmental Conditions:	23°C, 67% RH	Tested By:	Chris Lin
--------------	--------	---------------------------	--------------	------------	-----------

802.11a

Channel	Frequency (MHz)	6 dB Bandwidth (MHz)		Minimum Limit (MHz)	Test Result
		Chain 0	Chain 1		
144 (U-NII-3)	5720	2.91	3.00	0.5	Pass
149	5745	16.33	16.32	0.5	Pass
157	5785	16.33	16.08	0.5	Pass
165	5825	16.31	16.07	0.5	Pass

802.11ax (HE20)

Channel	Frequency (MHz)	6 dB Bandwidth (MHz)		Minimum Limit (MHz)	Test Result
		Chain 0	Chain 1		
144 (U-NII-3)	5720	4.21	4.17	0.5	Pass
149	5745	18.66	18.00	0.5	Pass
157	5785	18.23	18.12	0.5	Pass
165	5825	18.34	17.63	0.5	Pass

802.11ax (HE40)

Channel	Frequency (MHz)	6 dB Bandwidth (MHz)		Minimum Limit (MHz)	Test Result
		Chain 0	Chain 1		
142 (U-NII-3)	5710	3.84	4.02	0.5	Pass
151	5755	37.79	37.87	0.5	Pass
159	5795	37.51	37.51	0.5	Pass

802.11ax (HE80)

Channel	Frequency (MHz)	6 dB Bandwidth (MHz)		Minimum Limit (MHz)	Test Result
		Chain 0	Chain 1		
138 (U-NII-3)	5690	3.40	3.12	0.5	Pass
155	5775	75.49	77.49	0.5	Pass



Spectrum Plot of Minimum Value

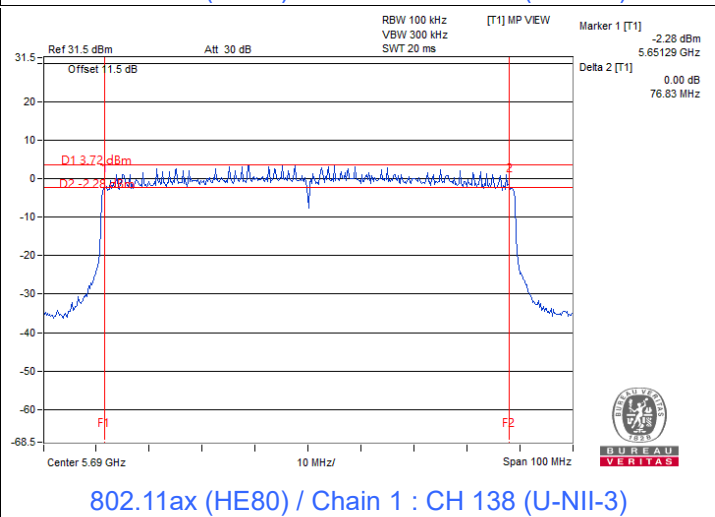
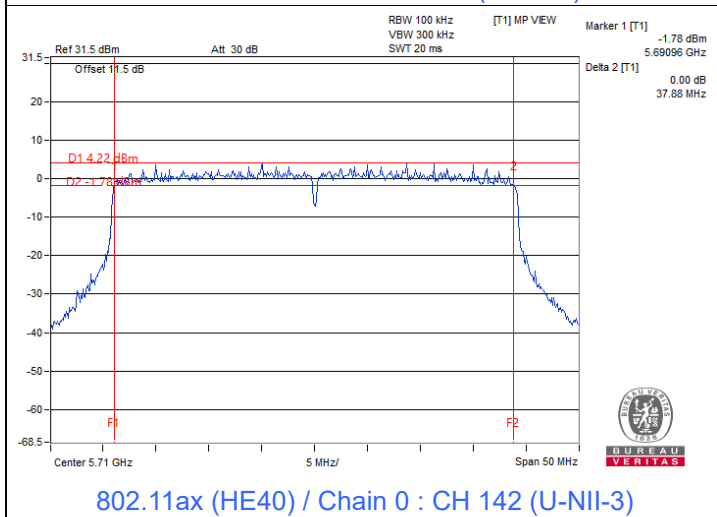
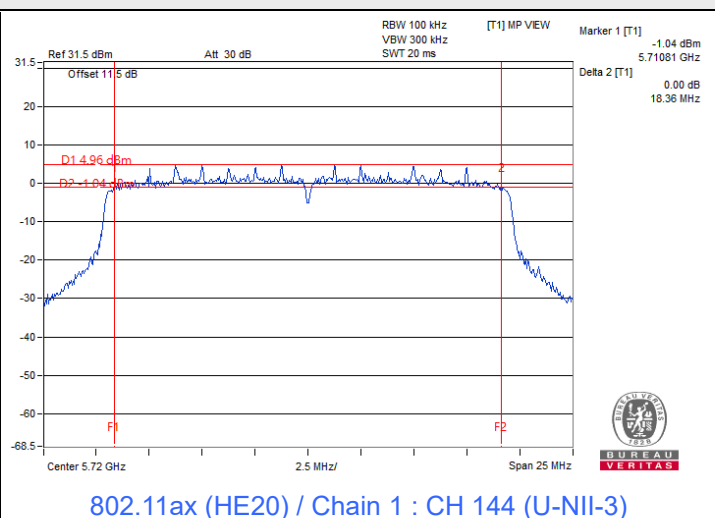
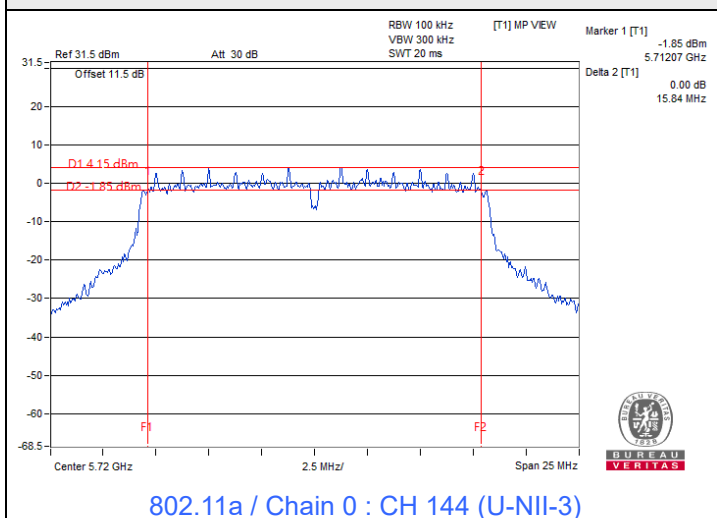

Note: For U-NII-3 straddle channel = Marker 1 + Delta 2 - 5725 MHz

7.5 Occupied Bandwidth

Input Power:	54 Vdc	Environmental Conditions:	23°C, 67% RH	Tested By:	Chris Lin
--------------	--------	---------------------------	--------------	------------	-----------

802.11a

Channel	Frequency (MHz)	Occupied Bandwidth (MHz)	
		Chain 0	Chain 1
36	5180	16.44	16.44
40	5200	16.44	16.44
48	5240	16.44	16.44
52	5260	16.56	16.56
60	5300	16.44	16.56
64	5320	16.56	16.56
100	5500	16.56	16.56
116	5580	16.56	16.44
140	5700	16.44	16.44
144 (U-NII-2C)	5720	13.28	13.28
144 (U-NII-3)	5720	3.16	3.28
149	5745	16.56	16.56
157	5785	16.56	16.44
165	5825	16.44	16.56

802.11ax (HE20)

Channel	Frequency (MHz)	Occupied Bandwidth (MHz)	
		Chain 0	Chain 1
36	5180	18.96	18.96
40	5200	18.96	19.08
48	5240	18.96	18.96
52	5260	18.96	19.08
60	5300	18.96	18.96
64	5320	19.08	18.96
100	5500	19.08	19.08
116	5580	19.08	19.08
140	5700	18.96	18.96
144 (U-NII-2C)	5720	14.48	14.48
144 (U-NII-3)	5720	4.48	4.48
149	5745	18.96	18.96
157	5785	18.96	19.08
165	5825	18.96	18.96

802.11ax (HE40)

Channel	Frequency (MHz)	Occupied Bandwidth (MHz)	
		Chain 0	Chain 1
38	5190	37.92	37.92
46	5230	37.92	37.92
54	5270	38.64	38.64
62	5310	37.92	38.64
102	5510	37.92	38.16
110	5550	37.92	37.92
134	5670	37.92	37.92
142 (U-NII-2C)	5710	33.96	33.96
142 (U-NII-3)	5710	3.96	3.96
151	5755	38.04	38.16
159	5795	38.04	38.04

802.11ax (HE80)

Channel	Frequency (MHz)	Occupied Bandwidth (MHz)	
		Chain 0	Chain 1
42	5210	77.28	77.28
58	5290	78.24	77.76
106	5530	77.28	77.28
122	5610	77.28	77.28
138 (U-NII-2C)	5690	73.88	73.88
138 (U-NII-3)	5690	3.40	3.40
155	5775	77.28	77.28



Spectrum Plot of Maximum Value

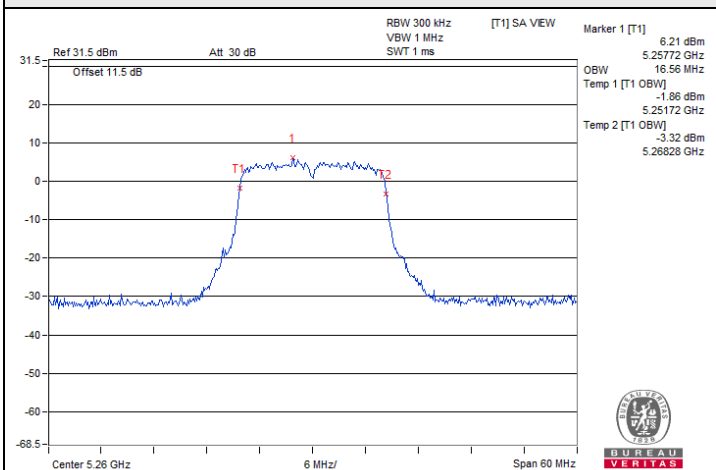

802.11a / Chain 0 : CH 52

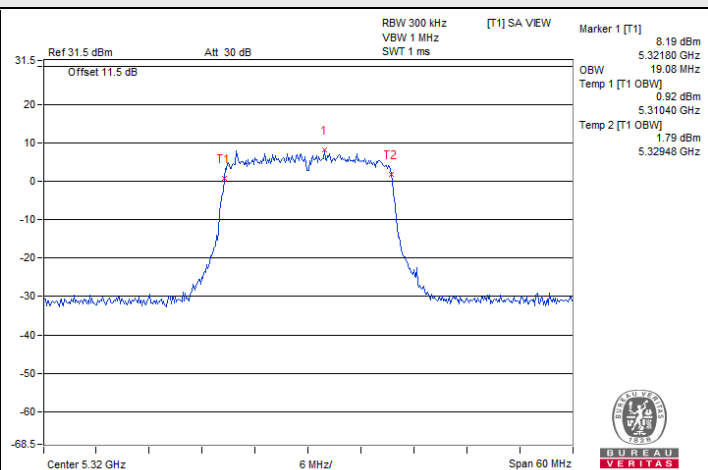

802.11ax (HE20) / Chain 0 : CH 64

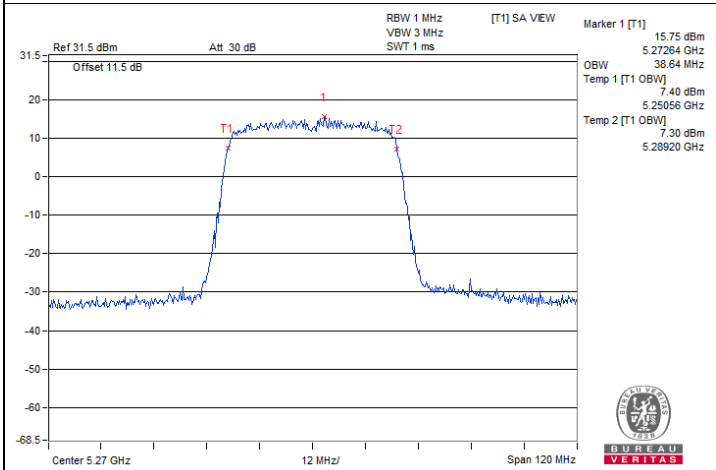

802.11ax (HE40) / Chain 0 : CH 54

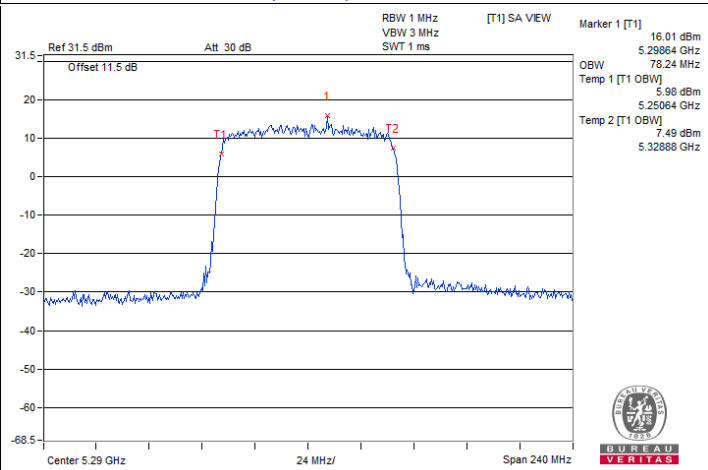

802.11ax (HE80) / Chain 0 : CH 58

Spectrum Plot for nearby DFS band (DFS is required, if 99% OCP straddle into U-NII-2A)

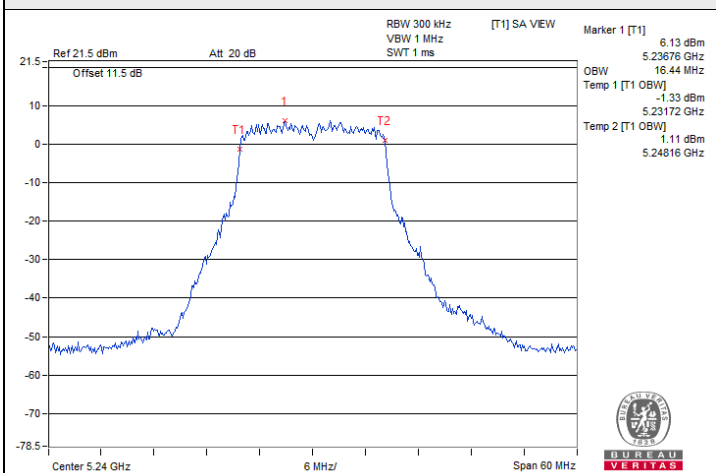

802.11a / Chain 0 : CH 48

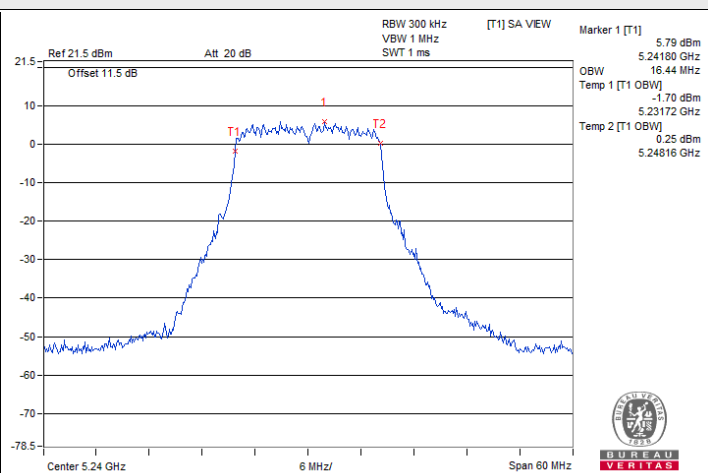

802.11a / Chain 1 : CH 48

Spectrum Plot for nearby DFS band (DFS is required, if 99% OCP straddle into U-NII-2A)

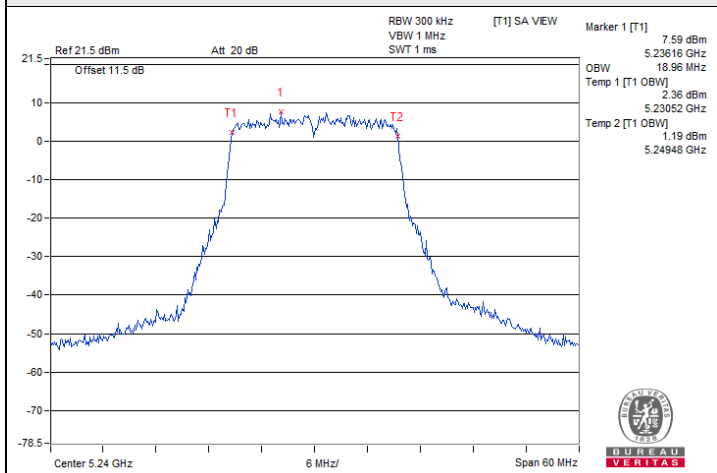

802.11ax (HE20) / Chain 0 : CH 48

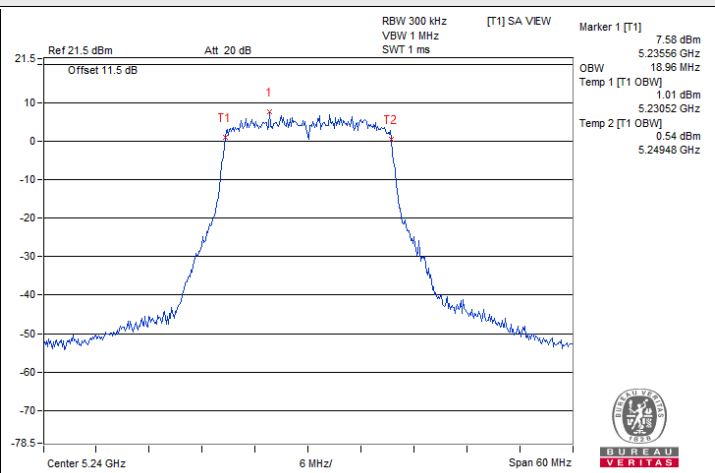

802.11ax (HE20) / Chain 1 : CH 48

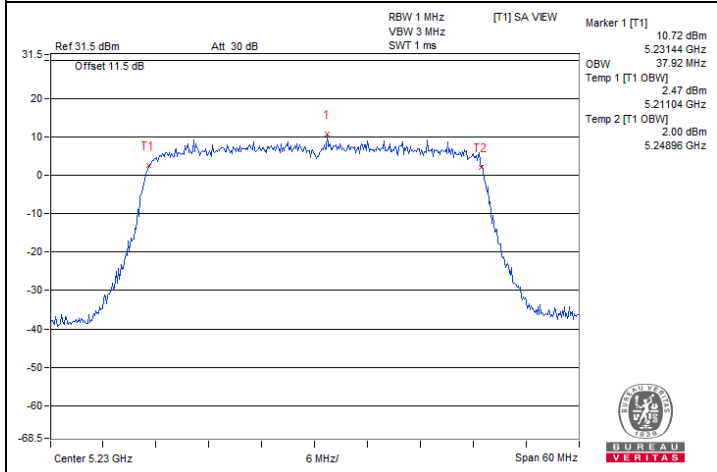

802.11ax (HE40) / Chain 0 : CH 46

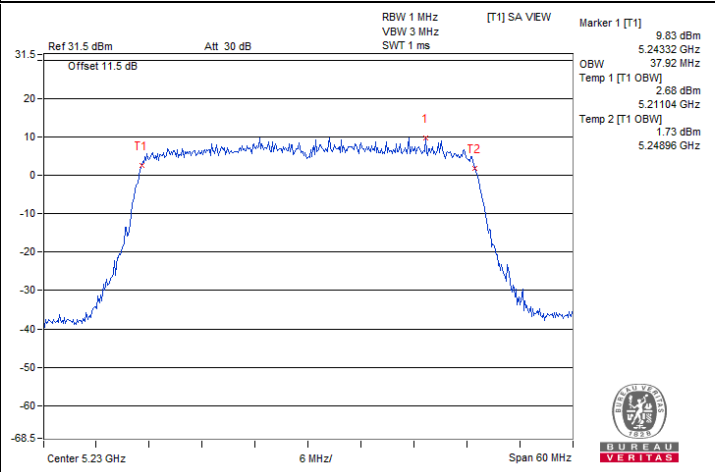

802.11ax (HE40) / Chain 1 : CH 46

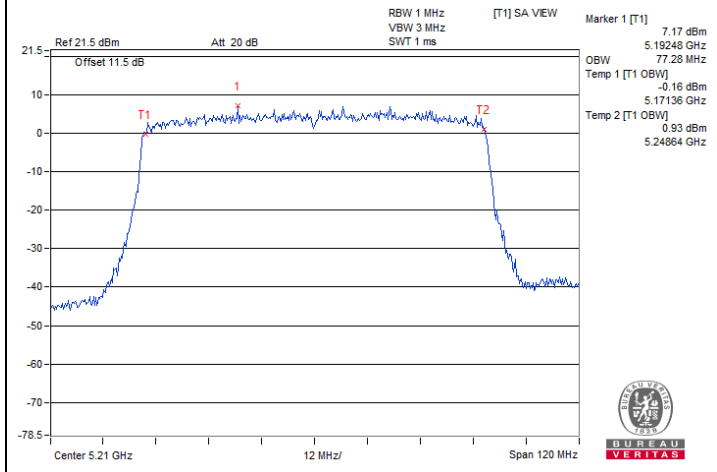

802.11ax (HE80) / Chain 0 : CH 42

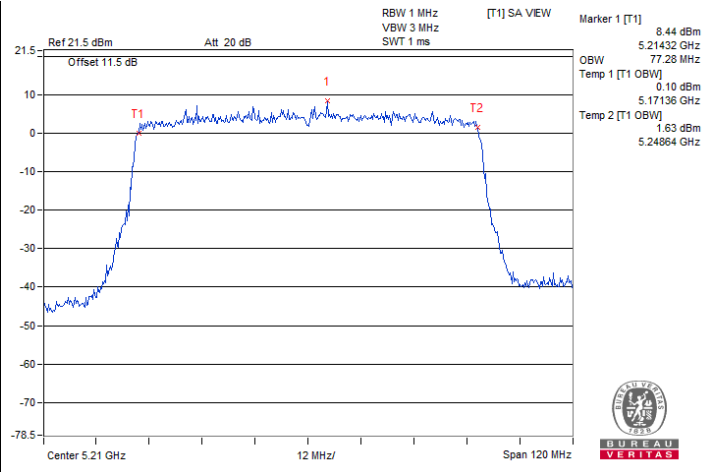

802.11ax (HE80) / Chain 1 : CH 42

Spectrum Plot for nearby DFS band (DFS is required, if 99% OCP straddle into U-NII-2C)

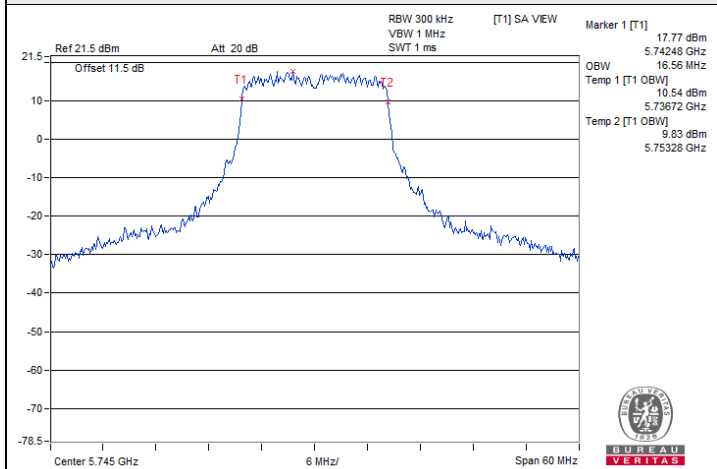
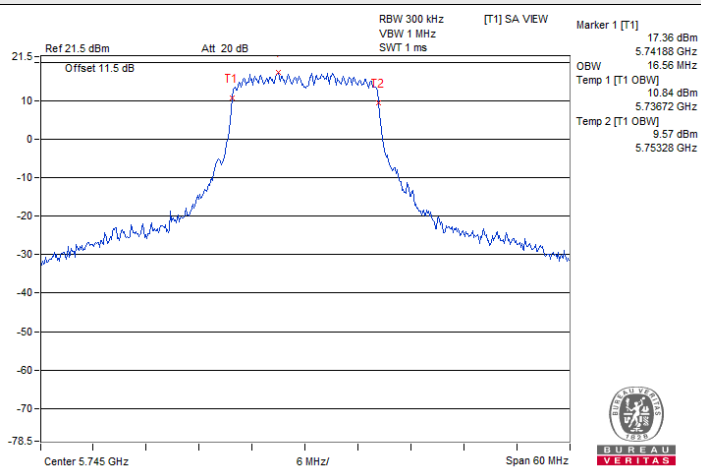
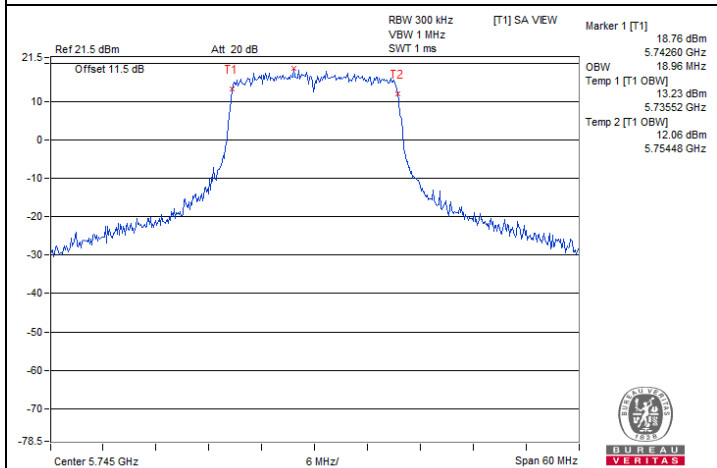
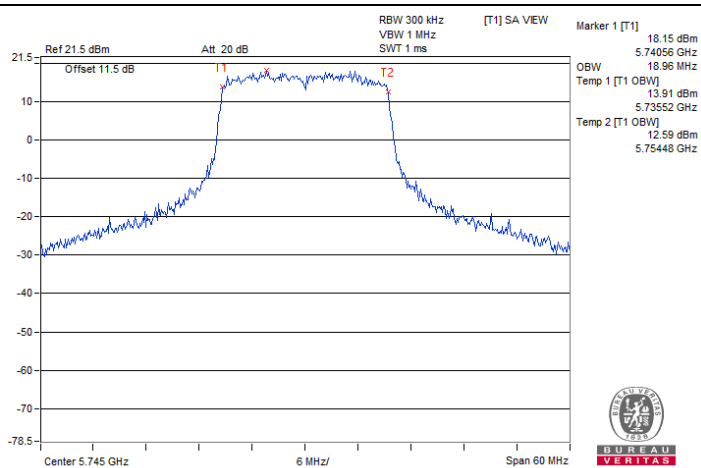
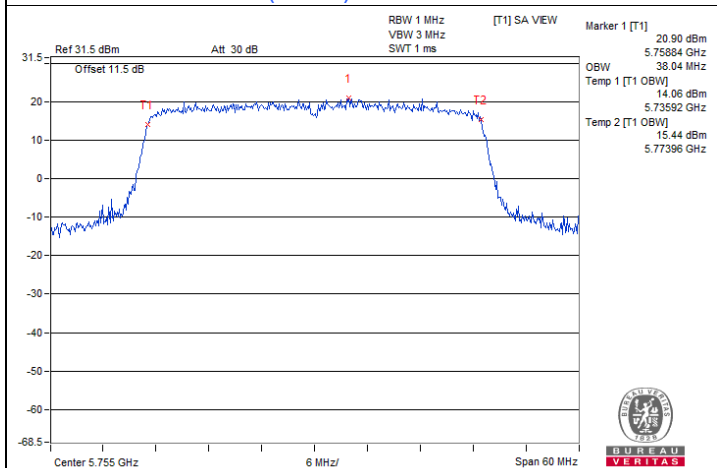
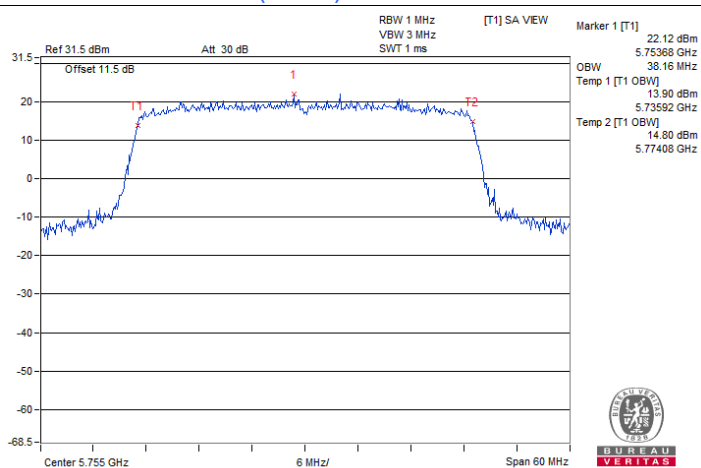
**802.11a / Chain 0 : CH 149****802.11a / Chain 1 : CH 149****802.11ax (HE20) / Chain 0 : CH 149****802.11ax (HE20) / Chain 1 : CH 149****802.11ax (HE40) / Chain 0 : CH 151****802.11ax (HE40) / Chain 1 : CH 151**



Spectrum Plot for nearby DFS band (DFS is required, if 99% OCP straddle into U-NII-2C)

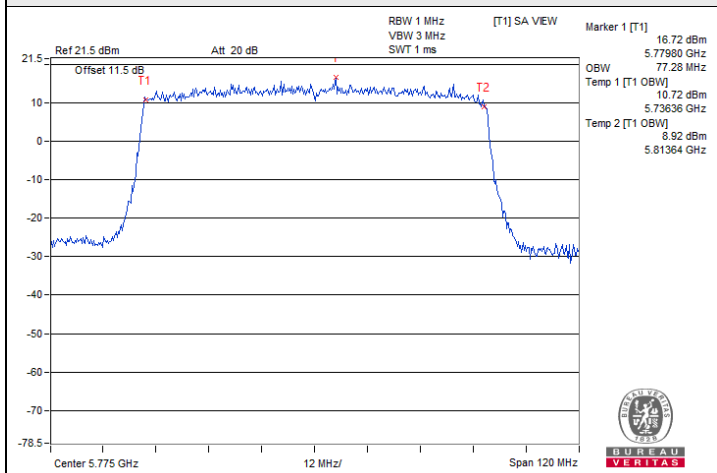

802.11ax (HE80) / Chain 0 : CH 155

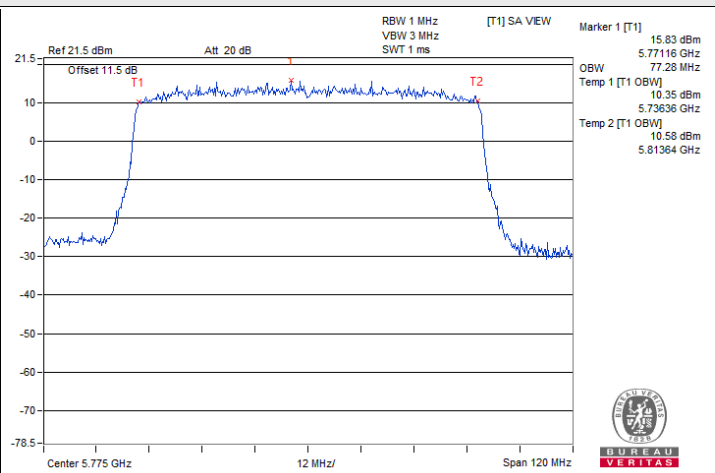

802.11ax (HE80) / Chain 1 : CH 155

7.6 Frequency Stability

Input Power:	54 Vdc	Environmental Conditions:	23°C, 67% RH	Tested By:	Chris Lin
--------------	--------	---------------------------	--------------	------------	-----------

Frequency Stability Versus Temperature									
Operating Frequency: 5180 MHz									
Temp. (°C)	Power Supply (Vdc)	0 Minute		2 Minutes		5 Minutes		10 Minutes	
		Measured Frequency (MHz)	Test Result	Measured Frequency (MHz)	Test Result	Measured Frequency (MHz)	Test Result	Measured Frequency (MHz)	Test Result
70	54	5180.0238	Pass	5180.0226	Pass	5180.0195	Pass	5180.0237	Pass
60	54	5180.0102	Pass	5180.006	Pass	5180.0095	Pass	5180.0095	Pass
50	54	5180.0007	Pass	5180.0021	Pass	5180.0043	Pass	5180.0004	Pass
40	54	5179.9969	Pass	5179.9987	Pass	5179.9969	Pass	5179.9973	Pass
30	54	5180.0095	Pass	5180.0092	Pass	5180.0086	Pass	5180.0091	Pass
20	54	5179.992	Pass	5179.989	Pass	5179.9915	Pass	5179.991	Pass
10	54	5180.0005	Pass	5180.0008	Pass	5179.9971	Pass	5179.9992	Pass
0	54	5180.0008	Pass	5180.0004	Pass	5179.9999	Pass	5179.9977	Pass
-10	54	5179.9946	Pass	5179.9914	Pass	5179.9933	Pass	5179.9928	Pass
-20	54	5180.0179	Pass	5180.0188	Pass	5180.0188	Pass	5180.0187	Pass
-30	54	5180.0103	Pass	5180.0096	Pass	5180.0089	Pass	5180.0119	Pass

Frequency Stability Versus Voltage									
Operating Frequency: 5180 MHz									
Temp. (°C)	Power Supply (Vdc)	0 Minute		2 Minutes		5 Minutes		10 Minutes	
		Measured Frequency (MHz)	Test Result	Measured Frequency (MHz)	Test Result	Measured Frequency (MHz)	Test Result	Measured Frequency (MHz)	Test Result
20	62.1	5180.0046	Pass	5180.001	Pass	5180.0013	Pass	5180.0016	Pass
	54	5179.992	Pass	5179.989	Pass	5179.9915	Pass	5179.991	Pass
	45.9	5179.988	Pass	5179.9843	Pass	5179.9888	Pass	5179.9861	Pass

7.7 AC Power Conducted Emissions

RF Mode	802.11ax (HE20)	Channel	CH 157 : 5785 MHz
Frequency Range	150 kHz ~ 30 MHz	Detector Function & Resolution Bandwidth	Quasi-Peak (QP) / Average (AV), 9 kHz
Input Power	120 Vac, 60 Hz	Environmental Conditions	23 °C, 67 % RH
Tested By	Karl Li		

Phase Of Power : Line (L)										
No	Frequency (MHz)	Correction Factor (dB)	Reading Value (dBuV)		Emission Level (dBuV)		Limit (dBuV)		Margin (dB)	
			Q.P.	AV.	Q.P.	AV.	Q.P.	AV.	Q.P.	AV.
1	0.15800	9.72	34.39	17.17	44.11	26.89	65.57	55.57	-21.46	-28.68
2	0.17000	9.72	32.62	16.54	42.34	26.26	64.96	54.96	-22.62	-28.70
3	0.29400	9.77	27.25	17.94	37.02	27.71	60.41	50.41	-23.39	-22.70
4	0.32976	9.79	31.07	22.81	40.86	32.60	59.46	49.46	-18.60	-16.86
5	7.92984	10.11	28.24	22.48	38.35	32.59	60.00	50.00	-21.65	-17.41
6	23.77000	10.54	32.33	32.26	42.87	42.80	60.00	50.00	-17.13	-7.20

Remarks:

1. Q.P. and AV. are abbreviations of quasi-peak and average individually.
2. The emission levels of other frequencies were very low against the limit.
3. Margin value = Emission level – Limit value
4. Correction factor = Insertion loss + Cable loss
5. Emission Level = Correction Factor + Reading Value

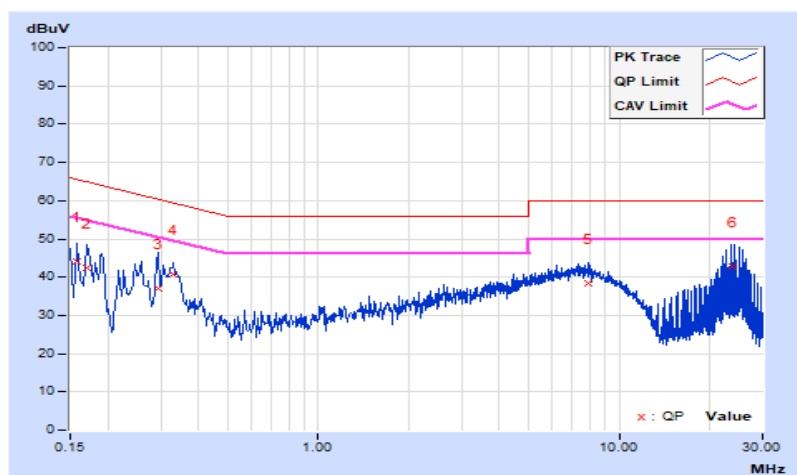

RF Mode	802.11ax (HE20)	Channel	CH 157 : 5785 MHz
Frequency Range	150 kHz ~ 30 MHz	Detector Function & Resolution Bandwidth	Quasi-Peak (QP) / Average (AV), 9 kHz
Input Power	120 Vac, 60 Hz	Environmental Conditions	23 °C, 67 % RH
Tested By	Karl Li		

Phase Of Power : Neutral (N)										
No	Frequency (MHz)	Correction Factor (dB)	Reading Value (dBuV)		Emission Level (dBuV)		Limit (dBuV)		Margin (dB)	
			Q.P.	AV.	Q.P.	AV.	Q.P.	AV.	Q.P.	AV.
1	0.17708	9.70	36.39	27.02	46.09	36.72	64.62	54.62	-18.53	-17.90
2	0.22600	9.73	25.77	14.59	35.50	24.32	62.60	52.60	-27.10	-28.28
3	0.34200	9.82	30.49	23.90	40.31	33.72	59.15	49.15	-18.84	-15.43
4	0.53000	9.88	17.42	9.57	27.30	19.45	56.00	46.00	-28.70	-26.55
5	7.20600	10.14	28.08	22.15	38.22	32.29	60.00	50.00	-21.78	-17.71
6	23.77000	10.71	32.01	31.86	42.72	42.57	60.00	50.00	-17.28	-7.43

Remarks:

1. Q.P. and AV. are abbreviations of quasi-peak and average individually.
2. The emission levels of other frequencies were very low against the limit.
3. Margin value = Emission level – Limit value
4. Correction factor = Insertion loss + Cable loss
5. Emission Level = Correction Factor + Reading Value

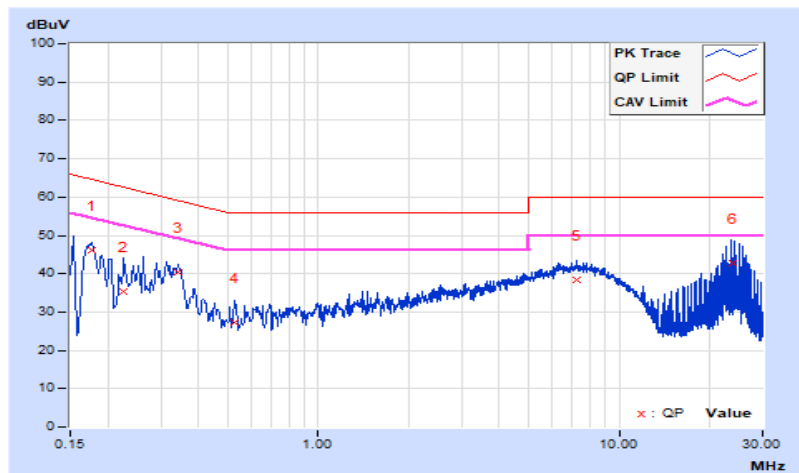

7.8 Unwanted Emissions below 1 GHz

RF Mode	802.11ax (HE20)	Channel	CH 157 : 5785 MHz
Frequency Range	30 MHz ~ 1 GHz	Detector Function & Bandwidth	QP: RB=120kHz, DET=Quasi-Peak
Input Power	120 Vac, 60 Hz	Environmental Conditions	23 °C, 67 % RH
Tested By	Karl Lee		

Antenna Polarity & Test Distance : Horizontal at 3 m								
No	Frequency (MHz)	Emission Level (dBuV/m)	Limit (dBuV/m)	Margin (dB)	Antenna Height (m)	Table Angle (Degree)	Raw Value (dBuV)	Correction Factor (dB/m)
1	82.38	29.3 QP	40.0	-10.7	1.52 H	253	47.7	-18.4
2	154.16	26.3 QP	43.5	-17.2	1.09 H	241	38.9	-12.6
3	304.51	36.5 QP	46.0	-9.5	1.72 H	24	48.8	-12.3
4	540.22	38.8 QP	46.0	-7.2	2.61 H	184	45.4	-6.6
5	622.67	35.1 QP	46.0	-10.9	1.36 H	226	39.7	-4.6
6	801.15	33.2 QP	46.0	-12.8	1.75 H	154	35.3	-2.1

Remarks:

1. Emission Level(dBuV/m) = Raw Value(dBuV) + Correction Factor(dB/m)
2. Correction Factor(dB/m) = Antenna Factor(dB/m) + Cable Factor(dB) – Pre-Amplifier Factor(dB)
3. Margin value = Emission Level – Limit value
4. The other emission levels were very low against the limit of frequency range 30 MHz ~ 1 GHz.
5. The frequency range 9 kHz ~ 30 MHz: all emissions are more than 20 dB below the limit, therefore do not be recorded in this report.

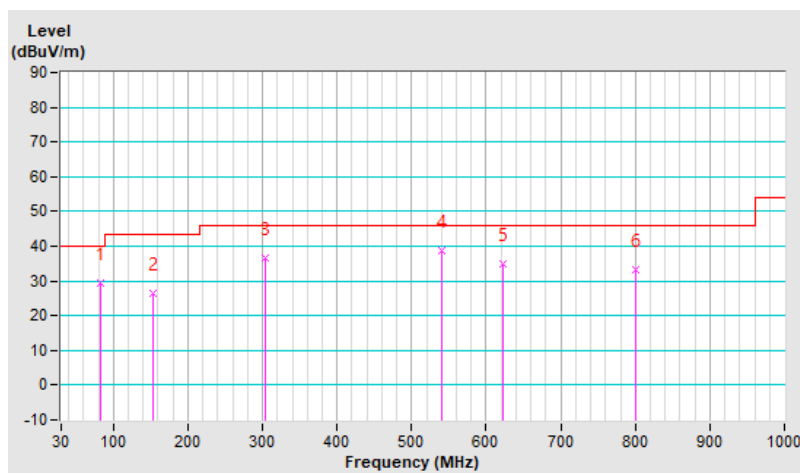

RF Mode	802.11ax (HE20)	Channel	CH 157 : 5785 MHz
Frequency Range	30 MHz ~ 1 GHz	Detector Function & Bandwidth	QP: RB=120kHz, DET=Quasi-Peak
Input Power	120 Vac, 60 Hz	Environmental Conditions	23 °C, 67 % RH
Tested By	Karl Lee		

Antenna Polarity & Test Distance : Vertical at 3 m								
No	Frequency (MHz)	Emission Level (dBuV/m)	Limit (dBuV/m)	Margin (dB)	Antenna Height (m)	Table Angle (Degree)	Raw Value (dBuV)	Correction Factor (dB/m)
1	89.17	29.2 QP	43.5	-14.3	1.72 V	206	48.0	-18.8
2	223.03	28.8 QP	46.0	-17.2	1.86 V	56	45.1	-16.3
3	300.63	38.6 QP	46.0	-7.4	2.75 V	151	51.0	-12.4
4	439.34	40.6 QP	46.0	-5.4	1.65 V	249	49.2	-8.6
5	612.97	41.7 QP	46.0	-4.3	1.62 V	175	46.4	-4.7
6	899.12	38.3 QP	46.0	-7.7	2.11 V	196	39.0	-0.7

Remarks:

1. Emission Level(dBuV/m) = Raw Value(dBuV) + Correction Factor(dB/m)
2. Correction Factor(dB/m) = Antenna Factor(dB/m) + Cable Factor(dB) – Pre-Amplifier Factor(dB)
3. Margin value = Emission Level – Limit value
4. The other emission levels were very low against the limit of frequency range 30 MHz ~ 1 GHz.
5. The frequency range 9 kHz ~ 30 MHz: all emissions are more than 20 dB below the limit, therefore do not be recorded in this report.

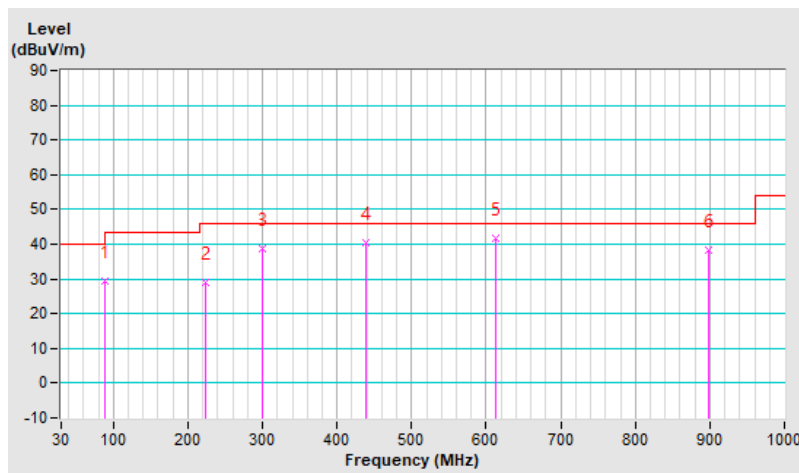

7.9 Unwanted Emissions above 1 GHz

RF Mode	802.11a	Channel	CH 36 : 5180 MHz
Frequency Range	1 GHz ~ 40 GHz	Detector Function & Bandwidth	PK: RB=1 MHz, VB=3 MHz, DET=Peak AV: RB=1 MHz, VB=1 kHz, DET=Peak
Input Power	120 Vac, 60 Hz	Environmental Conditions	21°C, 68% RH
Tested By	Karl Lee		

Antenna Polarity & Test Distance : Horizontal at 3 m								
No	Frequency (MHz)	Emission Level (dBuV/m)	Limit (dBuV/m)	Margin (dB)	Antenna Height (m)	Table Angle (Degree)	Raw Value (dBuV)	Correction Factor (dB/m)
1	5150.00	56.3 PK	74.0	-17.7	1.39 H	274	54.1	2.2
2	5150.00	45.0 AV	54.0	-9.0	1.39 H	274	42.8	2.2
3	*5180.00	102.8 PK			1.39 H	274	62.6	40.2
4	*5180.00	93.5 AV			1.39 H	274	53.3	40.2
5	#10360.00	56.4 PK	68.2	-11.8	1.51 H	321	48.5	7.9
Antenna Polarity & Test Distance : Vertical at 3 m								
No	Frequency (MHz)	Emission Level (dBuV/m)	Limit (dBuV/m)	Margin (dB)	Antenna Height (m)	Table Angle (Degree)	Raw Value (dBuV)	Correction Factor (dB/m)
1	4700.00	56.0 PK	74.0	-18.0	1.26 V	109	54.5	1.5
2	4700.00	44.8 AV	54.0	-9.2	1.26 V	109	43.3	1.5
3	*5180.00	112.5 PK			1.26 V	109	72.3	40.2
4	*5180.00	103.4 AV			1.26 V	109	63.2	40.2
5	#10360.00	57.5 PK	68.2	-10.7	1.11 V	10	49.6	7.9

Remarks:

1. Emission Level(dBuV/m) = Raw Value(dBuV) + Correction Factor(dB/m)
2. Correction Factor(dB/m) = Antenna Factor(dB/m) + Cable Factor(dB) – Pre-Amplifier Factor(dB)
3. Margin value = Emission Level – Limit value
4. The other emission levels were very low against the limit.
5. " * ": Fundamental frequency, the limit was restricted at the RF Output Power.
6. " # ": The radiated frequency is out of the restricted band.



RF Mode	802.11a	Channel	CH 40 : 5200 MHz
Frequency Range	1 GHz ~ 40 GHz	Detector Function & Bandwidth	PK: RB=1 MHz, VB=3 MHz, DET=Peak AV: RB=1 MHz, VB=1 kHz, DET=Peak
Input Power	120 Vac, 60 Hz	Environmental Conditions	21°C, 68% RH
Tested By	Karl Lee		

Antenna Polarity & Test Distance : Horizontal at 3 m								
No	Frequency (MHz)	Emission Level (dBuV/m)	Limit (dBuV/m)	Margin (dB)	Antenna Height (m)	Table Angle (Degree)	Raw Value (dBuV)	Correction Factor (dB/m)
1	*5200.00	102.8 PK			1.45 H	275	62.7	40.1
2	*5200.00	92.4 AV			1.45 H	275	52.3	40.1
3	#10400.00	56.5 PK	68.2	-11.7	1.45 H	304	48.6	7.9
Antenna Polarity & Test Distance : Vertical at 3 m								
No	Frequency (MHz)	Emission Level (dBuV/m)	Limit (dBuV/m)	Margin (dB)	Antenna Height (m)	Table Angle (Degree)	Raw Value (dBuV)	Correction Factor (dB/m)
1	*5200.00	112.1 PK			1.27 V	103	72.0	40.1
2	*5200.00	102.6 AV			1.27 V	103	62.5	40.1
3	#10400.00	54.8 PK	68.2	-13.4	1.69 V	56	46.9	7.9

Remarks:

1. Emission Level(dBuV/m) = Raw Value(dBuV) + Correction Factor(dB/m)
2. Correction Factor(dB/m) = Antenna Factor(dB/m) + Cable Factor(dB) – Pre-Amplifier Factor(dB)
3. Margin value = Emission Level – Limit value
4. The other emission levels were very low against the limit.
5. " * ": Fundamental frequency, the limit was restricted at the RF Output Power.
6. " # ": The radiated frequency is out of the restricted band.



RF Mode	802.11a	Channel	CH 48 : 5240 MHz
Frequency Range	1 GHz ~ 40 GHz	Detector Function & Bandwidth	PK: RB=1 MHz, VB=3 MHz, DET=Peak AV: RB=1 MHz, VB=1 kHz, DET=Peak
Input Power	120 Vac, 60 Hz	Environmental Conditions	21°C, 68% RH
Tested By	Karl Lee		

Antenna Polarity & Test Distance : Horizontal at 3 m

No	Frequency (MHz)	Emission Level (dBuV/m)	Limit (dBuV/m)	Margin (dB)	Antenna Height (m)	Table Angle (Degree)	Raw Value (dBuV)	Correction Factor (dB/m)
1	*5240.00	103.6 PK			1.76 H	195	63.6	40.0
2	*5240.00	94.1 AV			1.76 H	195	54.1	40.0
3	5350.00	54.5 PK	74.0	-19.5	1.76 H	195	52.6	1.9
4	5350.00	44.1 AV	54.0	-9.9	1.76 H	195	42.2	1.9
5	#10480.00	55.5 PK	68.2	-12.7	2.59 H	333	47.8	7.7

Antenna Polarity & Test Distance : Vertical at 3 m

No	Frequency (MHz)	Emission Level (dBuV/m)	Limit (dBuV/m)	Margin (dB)	Antenna Height (m)	Table Angle (Degree)	Raw Value (dBuV)	Correction Factor (dB/m)
1	*5240.00	112.4 PK			1.20 V	108	72.4	40.0
2	*5240.00	102.9 AV			1.20 V	108	62.9	40.0
3	5375.90	54.6 PK	74.0	-19.4	1.20 V	108	52.7	1.9
4	5375.90	45.6 AV	54.0	-8.4	1.20 V	108	43.7	1.9
5	#10480.00	56.4 PK	68.2	-11.8	1.59 V	327	48.7	7.7

Remarks:

1. Emission Level(dBuV/m) = Raw Value(dBuV) + Correction Factor(dB/m)
2. Correction Factor(dB/m) = Antenna Factor(dB/m) + Cable Factor(dB) – Pre-Amplifier Factor(dB)
3. Margin value = Emission Level – Limit value
4. The other emission levels were very low against the limit.
5. " * " : Fundamental frequency, the limit was restricted at the RF Output Power.
6. " # " : The radiated frequency is out of the restricted band.



RF Mode	802.11ax (HE20)	Channel	CH 36 : 5180 MHz
Frequency Range	1 GHz ~ 40 GHz	Detector Function & Bandwidth	PK: RB=1 MHz, VB=3 MHz, DET=Peak AV: RB=1 MHz, VB=1 kHz, DET=Peak
Input Power	120 Vac, 60 Hz	Environmental Conditions	21°C, 68% RH
Tested By	Karl Lee		

Antenna Polarity & Test Distance : Horizontal at 3 m

No	Frequency (MHz)	Emission Level (dBuV/m)	Limit (dBuV/m)	Margin (dB)	Antenna Height (m)	Table Angle (Degree)	Raw Value (dBuV)	Correction Factor (dB/m)
1	5150.00	55.8 PK	74.0	-18.2	1.58 H	196	53.6	2.2
2	5150.00	45.3 AV	54.0	-8.7	1.58 H	196	43.1	2.2
3	*5180.00	104.1 PK			1.58 H	196	63.9	40.2
4	*5180.00	92.8 AV			1.58 H	196	52.6	40.2
5	#10360.00	56.9 PK	68.2	-11.3	1.63 H	322	49.0	7.9

Antenna Polarity & Test Distance : Vertical at 3 m

No	Frequency (MHz)	Emission Level (dBuV/m)	Limit (dBuV/m)	Margin (dB)	Antenna Height (m)	Table Angle (Degree)	Raw Value (dBuV)	Correction Factor (dB/m)
1	5150.00	55.8 PK	74.0	-18.2	1.00 V	101	53.6	2.2
2	5150.00	45.8 AV	54.0	-8.2	1.00 V	101	43.6	2.2
3	*5180.00	114.7 PK			1.00 V	101	74.5	40.2
4	*5180.00	102.3 AV			1.00 V	101	62.1	40.2
5	#10360.00	57.2 PK	68.2	-11.0	1.08 V	357	49.3	7.9

Remarks:

1. Emission Level(dBuV/m) = Raw Value(dBuV) + Correction Factor(dB/m)
2. Correction Factor(dB/m) = Antenna Factor(dB/m) + Cable Factor(dB) – Pre-Amplifier Factor(dB)
3. Margin value = Emission Level – Limit value
4. The other emission levels were very low against the limit.
5. " * ": Fundamental frequency, the limit was restricted at the RF Output Power.
6. " # ": The radiated frequency is out of the restricted band.



RF Mode	802.11ax (HE20)	Channel	CH 40 : 5200 MHz
Frequency Range	1 GHz ~ 40 GHz	Detector Function & Bandwidth	PK: RB=1 MHz, VB=3 MHz, DET=Peak AV: RB=1 MHz, VB=1 kHz, DET=Peak
Input Power	120 Vac, 60 Hz	Environmental Conditions	21°C, 68% RH
Tested By	Karl Lee		

Antenna Polarity & Test Distance : Horizontal at 3 m								
No	Frequency (MHz)	Emission Level (dBuV/m)	Limit (dBuV/m)	Margin (dB)	Antenna Height (m)	Table Angle (Degree)	Raw Value (dBuV)	Correction Factor (dB/m)
1	*5200.00	103.6 PK			1.40 H	6	63.5	40.1
2	*5200.00	92.7 AV			1.40 H	6	52.6	40.1
3	#10400.00	56.3 PK	68.2	-11.9	1.56 H	321	48.4	7.9
Antenna Polarity & Test Distance : Vertical at 3 m								
No	Frequency (MHz)	Emission Level (dBuV/m)	Limit (dBuV/m)	Margin (dB)	Antenna Height (m)	Table Angle (Degree)	Raw Value (dBuV)	Correction Factor (dB/m)
1	*5200.00	113.7 PK			1.19 V	100	73.6	40.1
2	*5200.00	102.6 AV			1.19 V	100	62.5	40.1
3	#10400.00	56.0 PK	68.2	-12.2	1.20 V	356	48.1	7.9

Remarks:

1. Emission Level(dBuV/m) = Raw Value(dBuV) + Correction Factor(dB/m)
2. Correction Factor(dB/m) = Antenna Factor(dB/m) + Cable Factor(dB) – Pre-Amplifier Factor(dB)
3. Margin value = Emission Level – Limit value
4. The other emission levels were very low against the limit.
5. " * ": Fundamental frequency, the limit was restricted at the RF Output Power.
6. " # ": The radiated frequency is out of the restricted band.



RF Mode	802.11ax (HE20)	Channel	CH 48 : 5240 MHz
Frequency Range	1 GHz ~ 40 GHz	Detector Function & Bandwidth	PK: RB=1 MHz, VB=3 MHz, DET=Peak AV: RB=1 MHz, VB=1 kHz, DET=Peak
Input Power	120 Vac, 60 Hz	Environmental Conditions	21°C, 68% RH
Tested By	Karl Lee		

Antenna Polarity & Test Distance : Horizontal at 3 m								
No	Frequency (MHz)	Emission Level (dBuV/m)	Limit (dBuV/m)	Margin (dB)	Antenna Height (m)	Table Angle (Degree)	Raw Value (dBuV)	Correction Factor (dB/m)
1	*5240.00	104.3 PK			1.79 H	197	64.3	40.0
2	*5240.00	92.6 AV			1.79 H	197	52.6	40.0
3	5350.00	55.4 PK	74.0	-18.6	1.79 H	197	53.5	1.9
4	5350.00	43.9 AV	54.0	-10.1	1.79 H	197	42.0	1.9
5	#10480.00	55.9 PK	68.2	-12.3	1.74 H	335	48.2	7.7

Antenna Polarity & Test Distance : Vertical at 3 m								
No	Frequency (MHz)	Emission Level (dBuV/m)	Limit (dBuV/m)	Margin (dB)	Antenna Height (m)	Table Angle (Degree)	Raw Value (dBuV)	Correction Factor (dB/m)
1	*5240.00	113.7 PK			1.32 V	103	73.7	40.0
2	*5240.00	102.4 AV			1.32 V	103	62.4	40.0
3	5376.00	55.4 PK	74.0	-18.6	1.32 V	103	53.5	1.9
4	5376.00	45.3 AV	54.0	-8.7	1.32 V	103	43.4	1.9
5	#10480.00	55.5 PK	68.2	-12.7	1.57 V	330	47.8	7.7

Remarks:

1. Emission Level(dBuV/m) = Raw Value(dBuV) + Correction Factor(dB/m)
2. Correction Factor(dB/m) = Antenna Factor(dB/m) + Cable Factor(dB) – Pre-Amplifier Factor(dB)
3. Margin value = Emission Level – Limit value
4. The other emission levels were very low against the limit.
5. " * " : Fundamental frequency, the limit was restricted at the RF Output Power.
6. " # " : The radiated frequency is out of the restricted band.



RF Mode	802.11ax (HE40)	Channel	CH 38 : 5190 MHz
Frequency Range	1 GHz ~ 40 GHz	Detector Function & Bandwidth	PK: RB=1 MHz, VB=3 MHz, DET=Peak AV: RB=1 MHz, VB=1 kHz, DET=Peak
Input Power	120 Vac, 60 Hz	Environmental Conditions	21°C, 68% RH
Tested By	Karl Lee		

Antenna Polarity & Test Distance : Horizontal at 3 m

No	Frequency (MHz)	Emission Level (dBuV/m)	Limit (dBuV/m)	Margin (dB)	Antenna Height (m)	Table Angle (Degree)	Raw Value (dBuV)	Correction Factor (dB/m)
1	5150.00	55.2 PK	74.0	-18.8	1.53 H	193	53.0	2.2
2	5150.00	45.7 AV	54.0	-8.3	1.53 H	193	43.5	2.2
3	*5190.00	100.4 PK			1.53 H	193	60.2	40.2
4	*5190.00	90.4 AV			1.53 H	193	50.2	40.2
5	#10380.00	56.2 PK	68.2	-12.0	1.62 H	322	48.3	7.9

Antenna Polarity & Test Distance : Vertical at 3 m

No	Frequency (MHz)	Emission Level (dBuV/m)	Limit (dBuV/m)	Margin (dB)	Antenna Height (m)	Table Angle (Degree)	Raw Value (dBuV)	Correction Factor (dB/m)
1	5150.00	56.0 PK	74.0	-18.0	1.22 V	103	53.8	2.2
2	5150.00	45.2 AV	54.0	-8.8	1.22 V	103	43.0	2.2
3	*5190.00	109.2 PK			1.22 V	103	69.0	40.2
4	*5190.00	99.6 AV			1.22 V	103	59.4	40.2
5	#10380.00	56.3 PK	68.2	-11.9	1.21 V	357	48.4	7.9

Remarks:

1. Emission Level(dBuV/m) = Raw Value(dBuV) + Correction Factor(dB/m)
2. Correction Factor(dB/m) = Antenna Factor(dB/m) + Cable Factor(dB) – Pre-Amplifier Factor(dB)
3. Margin value = Emission Level – Limit value
4. The other emission levels were very low against the limit.
5. " * ": Fundamental frequency, the limit was restricted at the RF Output Power.
6. " # ": The radiated frequency is out of the restricted band.



RF Mode	802.11ax (HE40)	Channel	CH 46 : 5230 MHz
Frequency Range	1 GHz ~ 40 GHz	Detector Function & Bandwidth	PK: RB=1 MHz, VB=3 MHz, DET=Peak AV: RB=1 MHz, VB=1 kHz, DET=Peak
Input Power	120 Vac, 60 Hz	Environmental Conditions	21°C, 68% RH
Tested By	Karl Lee		

Antenna Polarity & Test Distance : Horizontal at 3 m

No	Frequency (MHz)	Emission Level (dBuV/m)	Limit (dBuV/m)	Margin (dB)	Antenna Height (m)	Table Angle (Degree)	Raw Value (dBuV)	Correction Factor (dB/m)
1	*5230.00	101.4 PK			1.85 H	194	61.4	40.0
2	*5230.00	90.2 AV			1.85 H	194	50.2	40.0
3	5350.00	55.1 PK	74.0	-18.9	1.85 H	194	53.2	1.9
4	5350.00	44.1 AV	54.0	-9.9	1.85 H	194	42.2	1.9
5	#10460.00	56.6 PK	68.2	-11.6	1.47 H	302	48.8	7.8

Antenna Polarity & Test Distance : Vertical at 3 m

No	Frequency (MHz)	Emission Level (dBuV/m)	Limit (dBuV/m)	Margin (dB)	Antenna Height (m)	Table Angle (Degree)	Raw Value (dBuV)	Correction Factor (dB/m)
1	*5230.00	110.8 PK			1.42 V	98	70.8	40.0
2	*5230.00	99.6 AV			1.42 V	98	59.6	40.0
3	5350.00	55.0 PK	74.0	-19.0	1.42 V	98	53.1	1.9
4	5350.00	45.0 AV	54.0	-9.0	1.42 V	98	43.1	1.9
5	#10460.00	56.0 PK	68.2	-12.2	1.49 V	351	48.2	7.8

Remarks:

1. Emission Level(dBuV/m) = Raw Value(dBuV) + Correction Factor(dB/m)
2. Correction Factor(dB/m) = Antenna Factor(dB/m) + Cable Factor(dB) – Pre-Amplifier Factor(dB)
3. Margin value = Emission Level – Limit value
4. The other emission levels were very low against the limit.
5. " * " : Fundamental frequency, the limit was restricted at the RF Output Power.
6. " # " : The radiated frequency is out of the restricted band.

RF Mode	802.11ax (HE80)	Channel	CH 42 : 5210 MHz
Frequency Range	1 GHz ~ 40 GHz	Detector Function & Bandwidth	PK: RB=1 MHz, VB=3 MHz, DET=Peak AV: RB=1 MHz, VB=1 kHz, DET=Peak
Input Power	120 Vac, 60 Hz	Environmental Conditions	21°C, 68% RH
Tested By	Karl Lee		

Antenna Polarity & Test Distance : Horizontal at 3 m

No	Frequency (MHz)	Emission Level (dBuV/m)	Limit (dBuV/m)	Margin (dB)	Antenna Height (m)	Table Angle (Degree)	Raw Value (dBuV)	Correction Factor (dB/m)
1	*5210.00	97.2 PK			1.73 H	194	57.1	40.1
2	*5210.00	87.1 AV			1.73 H	194	47.0	40.1
3	5350.00	54.3 PK	74.0	-19.7	1.73 H	194	52.4	1.9
4	5350.00	44.3 AV	54.0	-9.7	1.73 H	194	42.4	1.9
5	#10420.00	57.3 PK	68.2	-10.9	1.48 H	303	49.4	7.9

Antenna Polarity & Test Distance : Vertical at 3 m

No	Frequency (MHz)	Emission Level (dBuV/m)	Limit (dBuV/m)	Margin (dB)	Antenna Height (m)	Table Angle (Degree)	Raw Value (dBuV)	Correction Factor (dB/m)
1	*5210.00	108.1 PK			1.18 V	99	68.0	40.1
2	*5210.00	97.0 AV			1.18 V	99	56.9	40.1
3	5350.00	54.9 PK	74.0	-19.1	1.19 V	99	53.0	1.9
4	5350.00	45.6 AV	54.0	-8.4	1.19 V	99	43.7	1.9
5	#10420.00	57.4 PK	68.2	-10.8	1.00 V	351	49.5	7.9

Remarks:

1. Emission Level(dBuV/m) = Raw Value(dBuV) + Correction Factor(dB/m)
2. Correction Factor(dB/m) = Antenna Factor(dB/m) + Cable Factor(dB) – Pre-Amplifier Factor(dB)
3. Margin value = Emission Level – Limit value
4. The other emission levels were very low against the limit.
5. " * " : Fundamental frequency, the limit was restricted at the RF Output Power.
6. " # " : The radiated frequency is out of the restricted band.



RF Mode	802.11a	Channel	CH 52 : 5260 MHz
Frequency Range	1 GHz ~ 40 GHz	Detector Function & Bandwidth	PK: RB=1 MHz, VB=3 MHz, DET=Peak AV: RB=1 MHz, VB=1 kHz, DET=Peak
Input Power	120 Vac, 60 Hz	Environmental Conditions	23°C, 67% RH
Tested By	Karl Lee		

Antenna Polarity & Test Distance : Horizontal at 3 m

No	Frequency (MHz)	Emission Level (dBuV/m)	Limit (dBuV/m)	Margin (dB)	Antenna Height (m)	Table Angle (Degree)	Raw Value (dBuV)	Correction Factor (dB/m)
1	5150.00	57.8 PK	74.0	-16.2	1.11 H	204	55.0	2.8
2	5150.00	45.1 AV	54.0	-8.9	1.11 H	204	42.3	2.8
3	*5260.00	111.1 PK			1.11 H	204	70.8	40.3
4	*5260.00	101.5 AV			1.11 H	204	61.2	40.3
5	#10520.00	57.5 PK	68.2	-10.7	1.75 H	153	48.2	9.3

Antenna Polarity & Test Distance : Vertical at 3 m

No	Frequency (MHz)	Emission Level (dBuV/m)	Limit (dBuV/m)	Margin (dB)	Antenna Height (m)	Table Angle (Degree)	Raw Value (dBuV)	Correction Factor (dB/m)
1	5150.00	59.5 PK	74.0	-14.5	1.57 V	25	56.7	2.8
2	5150.00	45.9 AV	54.0	-8.1	1.57 V	25	43.1	2.8
3	*5260.00	123.4 PK			1.57 V	25	83.1	40.3
4	*5260.00	112.7 AV			1.57 V	25	72.4	40.3
5	#10520.00	56.9 PK	68.2	-11.3	1.28 V	263	47.6	9.3

Remarks:

1. Emission Level(dBuV/m) = Raw Value(dBuV) + Correction Factor(dB/m)
2. Correction Factor(dB/m) = Antenna Factor(dB/m) + Cable Factor(dB) – Pre-Amplifier Factor(dB)
3. Margin value = Emission Level – Limit value
4. The other emission levels were very low against the limit.
5. " * ": Fundamental frequency, the limit was restricted at the RF Output Power.
6. " # ": The radiated frequency is out of the restricted band.



RF Mode	802.11a	Channel	CH 60 : 5300 MHz
Frequency Range	1 GHz ~ 40 GHz	Detector Function & Bandwidth	PK: RB=1 MHz, VB=3 MHz, DET=Peak AV: RB=1 MHz, VB=1 kHz, DET=Peak
Input Power	120 Vac, 60 Hz	Environmental Conditions	23°C, 67% RH
Tested By	Karl Lee		

Antenna Polarity & Test Distance : Horizontal at 3 m

No	Frequency (MHz)	Emission Level (dBuV/m)	Limit (dBuV/m)	Margin (dB)	Antenna Height (m)	Table Angle (Degree)	Raw Value (dBuV)	Correction Factor (dB/m)
1	*5300.00	111.0 PK			1.09 H	208	70.6	40.4
2	*5300.00	101.4 AV			1.09 H	208	61.0	40.4
3	10600.00	57.8 PK	74.0	-16.2	1.68 H	151	48.4	9.4
4	10600.00	45.1 AV	54.0	-8.9	1.68 H	151	35.7	9.4

Antenna Polarity & Test Distance : Vertical at 3 m

No	Frequency (MHz)	Emission Level (dBuV/m)	Limit (dBuV/m)	Margin (dB)	Antenna Height (m)	Table Angle (Degree)	Raw Value (dBuV)	Correction Factor (dB/m)
1	*5300.00	123.3 PK			1.57 V	25	82.9	40.4
2	*5300.00	112.5 AV			1.57 V	25	72.1	40.4
3	10600.00	57.6 PK	74.0	-16.4	1.34 V	257	48.2	9.4
4	10600.00	44.8 AV	54.0	-9.2	1.34 V	257	35.4	9.4

Remarks:

1. Emission Level(dBuV/m) = Raw Value(dBuV) + Correction Factor(dB/m)
2. Correction Factor(dB/m) = Antenna Factor(dB/m) + Cable Factor(dB) – Pre-Amplifier Factor(dB)
3. Margin value = Emission Level – Limit value
4. The other emission levels were very low against the limit.
5. " * " : Fundamental frequency, the limit was restricted at the RF Output Power.



RF Mode	802.11a	Channel	CH 64 : 5320 MHz
Frequency Range	1 GHz ~ 40 GHz	Detector Function & Bandwidth	PK: RB=1 MHz, VB=3 MHz, DET=Peak AV: RB=1 MHz, VB=1 kHz, DET=Peak
Input Power	120 Vac, 60 Hz	Environmental Conditions	23°C, 67% RH
Tested By	Karl Lee		

Antenna Polarity & Test Distance : Horizontal at 3 m

No	Frequency (MHz)	Emission Level (dBuV/m)	Limit (dBuV/m)	Margin (dB)	Antenna Height (m)	Table Angle (Degree)	Raw Value (dBuV)	Correction Factor (dB/m)
1	*5320.00	115.4 PK			1.40 H	160	75.1	40.3
2	*5320.00	104.8 AV			1.40 H	160	64.5	40.3
3	5350.00	57.7 PK	74.0	-16.3	1.40 H	160	55.1	2.6
4	5350.00	46.3 AV	54.0	-7.7	1.40 H	160	43.7	2.6
5	10640.00	57.3 PK	74.0	-16.7	1.62 H	138	48.2	9.1
6	10640.00	44.6 AV	54.0	-9.4	1.62 H	138	35.5	9.1

Antenna Polarity & Test Distance : Vertical at 3 m

No	Frequency (MHz)	Emission Level (dBuV/m)	Limit (dBuV/m)	Margin (dB)	Antenna Height (m)	Table Angle (Degree)	Raw Value (dBuV)	Correction Factor (dB/m)
1	*5320.00	124.8 PK			1.54 V	25	84.5	40.3
2	*5320.00	114.2 AV			1.54 V	25	73.9	40.3
3	5350.00	62.1 PK	74.0	-11.9	1.54 V	25	59.5	2.6
4	5350.00	51.1 AV	54.0	-2.9	1.54 V	25	48.5	2.6
5	10640.00	56.9 PK	74.0	-17.1	1.59 V	161	47.8	9.1
6	10640.00	44.2 AV	54.0	-9.8	1.59 V	161	35.1	9.1

Remarks:

1. Emission Level(dBuV/m) = Raw Value(dBuV) + Correction Factor(dB/m)
2. Correction Factor(dB/m) = Antenna Factor(dB/m) + Cable Factor(dB) – Pre-Amplifier Factor(dB)
3. Margin value = Emission Level – Limit value
4. The other emission levels were very low against the limit.
5. " * ": Fundamental frequency, the limit was restricted at the RF Output Power.



RF Mode	802.11ax (HE20)	Channel	CH 52 : 5260 MHz
Frequency Range	1 GHz ~ 40 GHz	Detector Function & Bandwidth	PK: RB=1 MHz, VB=3 MHz, DET=Peak AV: RB=1 MHz, VB=1 kHz, DET=Peak
Input Power	120 Vac, 60 Hz	Environmental Conditions	25°C, 67% RH
Tested By	Karl Lee		

Antenna Polarity & Test Distance : Horizontal at 3 m

No	Frequency (MHz)	Emission Level (dBuV/m)	Limit (dBuV/m)	Margin (dB)	Antenna Height (m)	Table Angle (Degree)	Raw Value (dBuV)	Correction Factor (dB/m)
1	5150.00	57.9 PK	74.0	-16.1	1.52 H	158	55.1	2.8
2	5150.00	45.3 AV	54.0	-8.7	1.52 H	158	42.5	2.8
3	*5260.00	117.3 PK			1.52 H	158	77.0	40.3
4	*5260.00	102.7 AV			1.52 H	158	62.4	40.3
5	#10520.00	57.6 PK	68.2	-10.6	2.05 H	149	48.3	9.3

Antenna Polarity & Test Distance : Vertical at 3 m

No	Frequency (MHz)	Emission Level (dBuV/m)	Limit (dBuV/m)	Margin (dB)	Antenna Height (m)	Table Angle (Degree)	Raw Value (dBuV)	Correction Factor (dB/m)
1	5150.00	59.6 PK	74.0	-14.4	1.32 V	100	56.8	2.8
2	5150.00	47.1 AV	54.0	-6.9	1.32 V	100	44.3	2.8
3	*5260.00	126.8 PK			1.32 V	100	86.5	40.3
4	*5260.00	111.7 AV			1.32 V	100	71.4	40.3
5	#10520.00	57.4 PK	68.2	-10.8	1.93 V	52	48.1	9.3

Remarks:

1. Emission Level(dBuV/m) = Raw Value(dBuV) + Correction Factor(dB/m)
2. Correction Factor(dB/m) = Antenna Factor(dB/m) + Cable Factor(dB) – Pre-Amplifier Factor(dB)
3. Margin value = Emission Level – Limit value
4. The other emission levels were very low against the limit.
5. " * " : Fundamental frequency, the limit was restricted at the RF Output Power.
6. " # " : The radiated frequency is out of the restricted band.



RF Mode	802.11ax (HE20)	Channel	CH 60 : 5300 MHz
Frequency Range	1 GHz ~ 40 GHz	Detector Function & Bandwidth	PK: RB=1 MHz, VB=3 MHz, DET=Peak AV: RB=1 MHz, VB=1 kHz, DET=Peak
Input Power	120 Vac, 60 Hz	Environmental Conditions	25°C, 67% RH
Tested By	Karl Lee		

Antenna Polarity & Test Distance : Horizontal at 3 m

No	Frequency (MHz)	Emission Level (dBuV/m)	Limit (dBuV/m)	Margin (dB)	Antenna Height (m)	Table Angle (Degree)	Raw Value (dBuV)	Correction Factor (dB/m)
1	*5300.00	117.6 PK			1.52 H	158	77.2	40.4
2	*5300.00	102.9 AV			1.52 H	158	62.5	40.4
3	10600.00	57.4 PK	74.0	-16.6	1.69 H	31	48.0	9.4
4	10600.00	47.6 AV	54.0	-6.4	1.69 H	31	38.2	9.4

Antenna Polarity & Test Distance : Vertical at 3 m

No	Frequency (MHz)	Emission Level (dBuV/m)	Limit (dBuV/m)	Margin (dB)	Antenna Height (m)	Table Angle (Degree)	Raw Value (dBuV)	Correction Factor (dB/m)
1	*5300.00	126.6 PK			1.36 V	100	86.2	40.4
2	*5300.00	111.6 AV			1.36 V	100	71.2	40.4
3	10600.00	57.6 PK	74.0	-16.4	2.19 V	274	48.2	9.4
4	10600.00	44.8 AV	54.0	-9.2	2.19 V	274	35.4	9.4

Remarks:

1. Emission Level(dBuV/m) = Raw Value(dBuV) + Correction Factor(dB/m)
2. Correction Factor(dB/m) = Antenna Factor(dB/m) + Cable Factor(dB) – Pre-Amplifier Factor(dB)
3. Margin value = Emission Level – Limit value
4. The other emission levels were very low against the limit.
5. " * " : Fundamental frequency, the limit was restricted at the RF Output Power.



RF Mode	802.11ax (HE20)	Channel	CH 64 : 5320 MHz
Frequency Range	1 GHz ~ 40 GHz	Detector Function & Bandwidth	PK: RB=1 MHz, VB=3 MHz, DET=Peak AV: RB=1 MHz, VB=1 kHz, DET=Peak
Input Power	120 Vac, 60 Hz	Environmental Conditions	25°C, 67% RH
Tested By	Karl Lee		

Antenna Polarity & Test Distance : Horizontal at 3 m

No	Frequency (MHz)	Emission Level (dBuV/m)	Limit (dBuV/m)	Margin (dB)	Antenna Height (m)	Table Angle (Degree)	Raw Value (dBuV)	Correction Factor (dB/m)
1	*5320.00	118.5 PK			1.49 H	159	78.2	40.3
2	*5320.00	103.2 AV			1.49 H	159	62.9	40.3
3	5350.00	58.4 PK	74.0	-15.6	1.49 H	159	55.8	2.6
4	5350.00	46.6 AV	54.0	-7.4	1.49 H	159	44.0	2.6
5	10640.00	57.4 PK	74.0	-16.6	2.71 H	95	48.3	9.1
6	10640.00	44.7 AV	54.0	-9.3	2.71 H	95	35.6	9.1

Antenna Polarity & Test Distance : Vertical at 3 m

No	Frequency (MHz)	Emission Level (dBuV/m)	Limit (dBuV/m)	Margin (dB)	Antenna Height (m)	Table Angle (Degree)	Raw Value (dBuV)	Correction Factor (dB/m)
1	*5320.00	127.0 PK			1.32 V	100	86.7	40.3
2	*5320.00	112.3 AV			1.32 V	100	72.0	40.3
3	5350.00	62.8 PK	74.0	-11.2	1.32 V	100	60.2	2.6
4	5350.00	51.1 AV	54.0	-2.9	1.32 V	100	48.5	2.6
5	10640.00	56.8 PK	74.0	-17.2	1.60 V	245	47.7	9.1
6	10640.00	44.2 AV	54.0	-9.8	1.60 V	245	35.1	9.1

Remarks:

1. Emission Level(dBuV/m) = Raw Value(dBuV) + Correction Factor(dB/m)
2. Correction Factor(dB/m) = Antenna Factor(dB/m) + Cable Factor(dB) – Pre-Amplifier Factor(dB)
3. Margin value = Emission Level – Limit value
4. The other emission levels were very low against the limit.
5. " * ": Fundamental frequency, the limit was restricted at the RF Output Power.



RF Mode	802.11ax (HE40)	Channel	CH 54 : 5270 MHz
Frequency Range	1 GHz ~ 40 GHz	Detector Function & Bandwidth	PK: RB=1 MHz, VB=3 MHz, DET=Peak AV: RB=1 MHz, VB=1 kHz, DET=Peak
Input Power	120 Vac, 60 Hz	Environmental Conditions	25°C, 67% RH
Tested By	Karl Lee		

Antenna Polarity & Test Distance : Horizontal at 3 m

No	Frequency (MHz)	Emission Level (dBuV/m)	Limit (dBuV/m)	Margin (dB)	Antenna Height (m)	Table Angle (Degree)	Raw Value (dBuV)	Correction Factor (dB/m)
1	5150.00	57.8 PK	74.0	-16.2	1.62 H	158	55.0	2.8
2	5150.00	45.9 AV	54.0	-8.1	1.62 H	158	43.1	2.8
3	*5270.00	115.3 PK			1.62 H	158	75.0	40.3
4	*5270.00	100.6 AV			1.62 H	158	60.3	40.3
5	5350.00	58.1 PK	74.0	-15.9	1.62 H	158	55.5	2.6
6	5350.00	45.8 AV	54.0	-8.2	1.62 H	158	43.2	2.6
7	#10540.00	56.9 PK	68.2	-11.3	1.28 H	271	47.6	9.3

Antenna Polarity & Test Distance : Vertical at 3 m

No	Frequency (MHz)	Emission Level (dBuV/m)	Limit (dBuV/m)	Margin (dB)	Antenna Height (m)	Table Angle (Degree)	Raw Value (dBuV)	Correction Factor (dB/m)
1	5150.00	60.2 PK	74.0	-13.8	1.36 V	100	57.4	2.8
2	5150.00	47.4 AV	54.0	-6.6	1.36 V	100	44.6	2.8
3	*5270.00	126.0 PK			1.36 V	100	85.7	40.3
4	*5270.00	110.4 AV			1.36 V	100	70.1	40.3
5	5350.00	61.6 PK	74.0	-12.4	1.36 V	100	59.0	2.6
6	5350.00	49.2 AV	54.0	-4.8	1.36 V	100	46.6	2.6
7	#10540.00	57.8 PK	68.2	-10.4	1.18 V	167	48.5	9.3

Remarks:

1. Emission Level(dBuV/m) = Raw Value(dBuV) + Correction Factor(dB/m)
2. Correction Factor(dB/m) = Antenna Factor(dB/m) + Cable Factor(dB) – Pre-Amplifier Factor(dB)
3. Margin value = Emission Level – Limit value
4. The other emission levels were very low against the limit.
5. " * " : Fundamental frequency, the limit was restricted at the RF Output Power.
6. " # " : The radiated frequency is out of the restricted band.



RF Mode	802.11ax (HE40)	Channel	CH 62 : 5310 MHz
Frequency Range	1 GHz ~ 40 GHz	Detector Function & Bandwidth	PK: RB=1 MHz, VB=3 MHz, DET=Peak AV: RB=1 MHz, VB=1 kHz, DET=Peak
Input Power	120 Vac, 60 Hz	Environmental Conditions	25°C, 67% RH
Tested By	Karl Lee		

Antenna Polarity & Test Distance : Horizontal at 3 m								
No	Frequency (MHz)	Emission Level (dBuV/m)	Limit (dBuV/m)	Margin (dB)	Antenna Height (m)	Table Angle (Degree)	Raw Value (dBuV)	Correction Factor (dB/m)
1	5150.00	58.1 PK	74.0	-15.9	1.52 H	156	55.3	2.8
2	5150.00	45.5 AV	54.0	-8.5	1.52 H	156	42.7	2.8
3	*5310.00	113.4 PK			1.52 H	156	73.1	40.3
4	*5310.00	98.8 AV			1.52 H	156	58.5	40.3
5	5350.00	59.4 PK	74.0	-14.6	1.52 H	156	56.8	2.6
6	5350.00	47.1 AV	54.0	-6.9	1.52 H	156	44.5	2.6
7	10620.00	57.6 PK	74.0	-16.4	1.97 H	154	48.4	9.2
8	10620.00	44.8 AV	54.0	-9.2	1.97 H	154	35.6	9.2
Antenna Polarity & Test Distance : Vertical at 3 m								
No	Frequency (MHz)	Emission Level (dBuV/m)	Limit (dBuV/m)	Margin (dB)	Antenna Height (m)	Table Angle (Degree)	Raw Value (dBuV)	Correction Factor (dB/m)
1	5150.00	59.7 PK	74.0	-14.3	1.36 V	100	56.9	2.8
2	5150.00	47.0 AV	54.0	-7.0	1.36 V	100	44.2	2.8
3	*5310.00	123.3 PK			1.36 V	100	83.0	40.3
4	*5310.00	108.9 AV			1.36 V	100	68.6	40.3
5	5350.00	65.8 PK	74.0	-8.2	1.36 V	100	63.2	2.6
6	5350.00	53.8 AV	54.0	-0.2	1.36 V	100	51.2	2.6
7	10620.00	57.1 PK	74.0	-16.9	2.63 V	151	47.9	9.2
8	10620.00	44.4 AV	54.0	-9.6	2.63 V	151	35.2	9.2

Remarks:

1. Emission Level(dBuV/m) = Raw Value(dBuV) + Correction Factor(dB/m)
2. Correction Factor(dB/m) = Antenna Factor(dB/m) + Cable Factor(dB) – Pre-Amplifier Factor(dB)
3. Margin value = Emission Level – Limit value
4. The other emission levels were very low against the limit.
5. " * ": Fundamental frequency, the limit was restricted at the RF Output Power.



RF Mode	802.11ax (HE80)	Channel	CH 58 : 5290 MHz
Frequency Range	1 GHz ~ 40 GHz	Detector Function & Bandwidth	PK: RB=1 MHz, VB=3 MHz, DET=Peak AV: RB=1 MHz, VB=1 kHz, DET=Peak
Input Power	120 Vac, 60 Hz	Environmental Conditions	25°C, 67% RH
Tested By	Karl Lee		

Antenna Polarity & Test Distance : Horizontal at 3 m

No	Frequency (MHz)	Emission Level (dBuV/m)	Limit (dBuV/m)	Margin (dB)	Antenna Height (m)	Table Angle (Degree)	Raw Value (dBuV)	Correction Factor (dB/m)
1	5150.00	58.0 PK	74.0	-16.0	1.58 H	158	55.2	2.8
2	5150.00	45.4 AV	54.0	-8.6	1.58 H	158	42.6	2.8
3	*5290.00	108.5 PK			1.58 H	158	68.1	40.4
4	*5290.00	93.5 AV			1.58 H	158	53.1	40.4
5	5350.00	58.4 PK	74.0	-15.6	1.58 H	158	55.8	2.6
6	5350.00	47.1 AV	54.0	-6.9	1.58 H	158	44.5	2.6
7	#10580.00	57.0 PK	68.2	-11.2	2.65 H	138	47.7	9.3

Antenna Polarity & Test Distance : Vertical at 3 m

No	Frequency (MHz)	Emission Level (dBuV/m)	Limit (dBuV/m)	Margin (dB)	Antenna Height (m)	Table Angle (Degree)	Raw Value (dBuV)	Correction Factor (dB/m)
1	5150.00	58.9 PK	74.0	-15.1	1.38 V	100	56.1	2.8
2	5150.00	46.9 AV	54.0	-7.1	1.38 V	100	44.1	2.8
3	*5290.00	116.9 PK			1.38 V	100	76.5	40.4
4	*5290.00	102.1 AV			1.38 V	100	61.7	40.4
5	5350.00	64.6 PK	74.0	-9.4	1.38 V	100	62.0	2.6
6	5350.00	53.7 AV	54.0	-0.3	1.38 V	100	51.1	2.6
7	#10580.00	57.5 PK	68.2	-10.7	1.65 V	284	48.2	9.3

Remarks:

1. Emission Level(dBuV/m) = Raw Value(dBuV) + Correction Factor(dB/m)
2. Correction Factor(dB/m) = Antenna Factor(dB/m) + Cable Factor(dB) – Pre-Amplifier Factor(dB)
3. Margin value = Emission Level – Limit value
4. The other emission levels were very low against the limit.
5. " * " : Fundamental frequency, the limit was restricted at the RF Output Power.
6. " # " : The radiated frequency is out of the restricted band.



RF Mode	802.11a	Channel	CH 100 : 5500 MHz
Frequency Range	1 GHz ~ 40 GHz	Detector Function & Bandwidth	PK: RB=1 MHz, VB=3 MHz, DET=Peak AV: RB=1 MHz, VB=1 kHz, DET=Peak
Input Power	120 Vac, 60 Hz	Environmental Conditions	23°C, 67% RH
Tested By	Karl Lee		

Antenna Polarity & Test Distance : Horizontal at 3 m

No	Frequency (MHz)	Emission Level (dBuV/m)	Limit (dBuV/m)	Margin (dB)	Antenna Height (m)	Table Angle (Degree)	Raw Value (dBuV)	Correction Factor (dB/m)
1	5460.00	58.4 PK	74.0	-15.6	1.79 H	149	55.6	2.8
2	5460.00	45.5 AV	54.0	-8.5	1.79 H	149	42.7	2.8
3	#5470.00	58.6 PK	68.2	-9.6	1.79 H	149	55.8	2.8
4	*5500.00	114.9 PK			1.79 H	149	74.5	40.4
5	*5500.00	104.7 AV			1.79 H	149	64.3	40.4
6	11000.00	57.8 PK	74.0	-16.2	1.43 H	280	48.1	9.7
7	11000.00	45.0 AV	54.0	-9.0	1.43 H	280	35.3	9.7

Antenna Polarity & Test Distance : Vertical at 3 m

No	Frequency (MHz)	Emission Level (dBuV/m)	Limit (dBuV/m)	Margin (dB)	Antenna Height (m)	Table Angle (Degree)	Raw Value (dBuV)	Correction Factor (dB/m)
1	5460.00	60.9 PK	74.0	-13.1	1.54 V	24	58.1	2.8
2	5460.00	49.4 AV	54.0	-4.6	1.54 V	24	46.6	2.8
3	#5470.00	63.8 PK	68.2	-4.4	1.54 V	24	61.0	2.8
4	*5500.00	124.4 PK			1.54 V	24	84.0	40.4
5	*5500.00	114.4 AV			1.54 V	24	74.0	40.4
6	11000.00	57.9 PK	74.0	-16.1	1.22 V	138	48.2	9.7
7	11000.00	45.2 AV	54.0	-8.8	1.22 V	138	35.5	9.7

Remarks:

1. Emission Level(dBuV/m) = Raw Value(dBuV) + Correction Factor(dB/m)
2. Correction Factor(dB/m) = Antenna Factor(dB/m) + Cable Factor(dB) – Pre-Amplifier Factor(dB)
3. Margin value = Emission Level – Limit value
4. The other emission levels were very low against the limit.
5. " * " : Fundamental frequency, the limit was restricted at the RF Output Power.
6. " # " : The radiated frequency is out of the restricted band.



RF Mode	802.11a	Channel	CH 116 : 5580 MHz
Frequency Range	1 GHz ~ 40 GHz	Detector Function & Bandwidth	PK: RB=1 MHz, VB=3 MHz, DET=Peak AV: RB=1 MHz, VB=1 kHz, DET=Peak
Input Power	120 Vac, 60 Hz	Environmental Conditions	23°C, 67% RH
Tested By	Karl Lee		

Antenna Polarity & Test Distance : Horizontal at 3 m

No	Frequency (MHz)	Emission Level (dBuV/m)	Limit (dBuV/m)	Margin (dB)	Antenna Height (m)	Table Angle (Degree)	Raw Value (dBuV)	Correction Factor (dB/m)
1	*5580.00	115.8 PK			1.81 H	160	74.7	41.1
2	*5580.00	105.7 AV			1.81 H	160	64.6	41.1
3	11160.00	57.2 PK	74.0	-16.8	1.74 H	298	47.8	9.4
4	11160.00	44.5 AV	54.0	-9.5	1.74 H	298	35.1	9.4

Antenna Polarity & Test Distance : Vertical at 3 m

No	Frequency (MHz)	Emission Level (dBuV/m)	Limit (dBuV/m)	Margin (dB)	Antenna Height (m)	Table Angle (Degree)	Raw Value (dBuV)	Correction Factor (dB/m)
1	*5580.00	125.3 PK			1.56 V	29	84.2	41.1
2	*5580.00	115.3 AV			1.56 V	29	74.2	41.1
3	11160.00	57.8 PK	74.0	-16.2	1.34 V	154	48.4	9.4
4	11160.00	44.9 AV	54.0	-9.1	1.34 V	154	35.5	9.4

Remarks:

1. Emission Level(dBuV/m) = Raw Value(dBuV) + Correction Factor(dB/m)
2. Correction Factor(dB/m) = Antenna Factor(dB/m) + Cable Factor(dB) – Pre-Amplifier Factor(dB)
3. Margin value = Emission Level – Limit value
4. The other emission levels were very low against the limit.
5. " * " : Fundamental frequency, the limit was restricted at the RF Output Power.



RF Mode	802.11a	Channel	CH 140 : 5700 MHz
Frequency Range	1 GHz ~ 40 GHz	Detector Function & Bandwidth	PK: RB=1 MHz, VB=3 MHz, DET=Peak AV: RB=1 MHz, VB=1 kHz, DET=Peak
Input Power	120 Vac, 60 Hz	Environmental Conditions	23°C, 67% RH
Tested By	Karl Lee		

Antenna Polarity & Test Distance : Horizontal at 3 m

No	Frequency (MHz)	Emission Level (dBuV/m)	Limit (dBuV/m)	Margin (dB)	Antenna Height (m)	Table Angle (Degree)	Raw Value (dBuV)	Correction Factor (dB/m)
1	*5700.00	112.3 PK			1.68 H	158	70.6	41.7
2	*5700.00	102.2 AV			1.68 H	158	60.5	41.7
3	#5725.00	59.5 PK	68.2	-8.7	1.68 H	158	55.5	4.0
4	11400.00	57.9 PK	74.0	-16.1	1.01 H	184	48.2	9.7
5	11400.00	45.1 AV	54.0	-8.9	1.01 H	184	35.4	9.7

Antenna Polarity & Test Distance : Vertical at 3 m

No	Frequency (MHz)	Emission Level (dBuV/m)	Limit (dBuV/m)	Margin (dB)	Antenna Height (m)	Table Angle (Degree)	Raw Value (dBuV)	Correction Factor (dB/m)
1	*5700.00	124.4 PK			1.90 V	8	82.7	41.7
2	*5700.00	113.8 AV			1.90 V	8	72.1	41.7
3	#5725.00	67.7 PK	68.2	-0.5	1.90 V	8	63.7	4.0
4	11400.00	57.7 PK	74.0	-16.3	1.15 V	249	48.0	9.7
5	11400.00	45.0 AV	54.0	-9.0	1.15 V	249	35.3	9.7

Remarks:

1. Emission Level(dBuV/m) = Raw Value(dBuV) + Correction Factor(dB/m)
2. Correction Factor(dB/m) = Antenna Factor(dB/m) + Cable Factor(dB) – Pre-Amplifier Factor(dB)
3. Margin value = Emission Level – Limit value
4. The other emission levels were very low against the limit.
5. " * " : Fundamental frequency, the limit was restricted at the RF Output Power.
6. " # " : The radiated frequency is out of the restricted band.



RF Mode	802.11a	Channel	CH 144 : 5720 MHz
Frequency Range	1 GHz ~ 40 GHz	Detector Function & Bandwidth	PK: RB=1 MHz, VB=3 MHz, DET=Peak AV: RB=1 MHz, VB=1 kHz, DET=Peak
Input Power	120 Vac, 60 Hz	Environmental Conditions	25°C, 67% RH
Tested By	Karl Lee		

Antenna Polarity & Test Distance : Horizontal at 3 m

No	Frequency (MHz)	Emission Level (dBuV/m)	Limit (dBuV/m)	Margin (dB)	Antenna Height (m)	Table Angle (Degree)	Raw Value (dBuV)	Correction Factor (dB/m)
1	5460.00	58.7 PK	74.0	-15.3	1.92 H	88	55.9	2.8
2	5460.00	45.1 AV	54.0	-8.9	1.92 H	88	42.3	2.8
3	#5470.00	57.2 PK	68.2	-11.0	1.92 H	88	54.4	2.8
4	*5720.00	113.4 PK			1.92 H	88	71.6	41.8
5	*5720.00	106.5 AV			1.92 H	88	64.7	41.8
6	11440.00	57.4 PK	74.0	-16.6	1.61 H	84	47.8	9.6
7	11440.00	44.5 AV	54.0	-9.5	1.61 H	84	34.9	9.6

Antenna Polarity & Test Distance : Vertical at 3 m

No	Frequency (MHz)	Emission Level (dBuV/m)	Limit (dBuV/m)	Margin (dB)	Antenna Height (m)	Table Angle (Degree)	Raw Value (dBuV)	Correction Factor (dB/m)
1	5460.00	59.7 PK	74.0	-14.3	1.85 V	20	56.9	2.8
2	5460.00	46.5 AV	54.0	-7.5	1.85 V	20	43.7	2.8
3	#5470.00	59.2 PK	68.2	-9.0	1.85 V	20	56.4	2.8
4	*5720.00	125.4 PK			1.85 V	20	83.6	41.8
5	*5720.00	115.6 AV			1.85 V	20	73.8	41.8
6	11440.00	57.9 PK	74.0	-16.1	1.56 V	281	48.3	9.6
7	11440.00	45.3 AV	54.0	-8.7	1.56 V	281	35.7	9.6

Remarks:

1. Emission Level(dBuV/m) = Raw Value(dBuV) + Correction Factor(dB/m)
2. Correction Factor(dB/m) = Antenna Factor(dB/m) + Cable Factor(dB) – Pre-Amplifier Factor(dB)
3. Margin value = Emission Level – Limit value
4. The other emission levels were very low against the limit.
5. " * " : Fundamental frequency, the limit was restricted at the RF Output Power.
6. " # " : The radiated frequency is out of the restricted band.



RF Mode	802.11ax (HE20)	Channel	CH 100 : 5500 MHz
Frequency Range	1 GHz ~ 40 GHz	Detector Function & Bandwidth	PK: RB=1 MHz, VB=3 MHz, DET=Peak AV: RB=1 MHz, VB=1 kHz, DET=Peak
Input Power	120 Vac, 60 Hz	Environmental Conditions	23°C, 67% RH
Tested By	Karl Lee		

Antenna Polarity & Test Distance : Horizontal at 3 m								
No	Frequency (MHz)	Emission Level (dBuV/m)	Limit (dBuV/m)	Margin (dB)	Antenna Height (m)	Table Angle (Degree)	Raw Value (dBuV)	Correction Factor (dB/m)
1	5460.00	58.0 PK	74.0	-16.0	1.52 H	157	55.2	2.8
2	5460.00	46.0 AV	54.0	-8.0	1.52 H	157	43.2	2.8
3	#5470.00	57.6 PK	68.2	-10.6	1.52 H	157	54.8	2.8
4	*5500.00	117.3 PK			1.52 H	157	76.9	40.4
5	*5500.00	102.2 AV			1.52 H	157	61.8	40.4
6	11000.00	57.7 PK	74.0	-16.3	2.06 H	128	48.0	9.7
7	11000.00	45.0 AV	54.0	-9.0	2.06 H	128	35.3	9.7
Antenna Polarity & Test Distance : Vertical at 3 m								
No	Frequency (MHz)	Emission Level (dBuV/m)	Limit (dBuV/m)	Margin (dB)	Antenna Height (m)	Table Angle (Degree)	Raw Value (dBuV)	Correction Factor (dB/m)
1	5460.00	62.2 PK	74.0	-11.8	1.48 V	100	59.4	2.8
2	5460.00	50.0 AV	54.0	-4.0	1.48 V	100	47.2	2.8
3	#5470.00	64.3 PK	68.2	-3.9	1.48 V	100	61.5	2.8
4	*5500.00	127.7 PK			1.48 V	100	87.3	40.4
5	*5500.00	112.6 AV			1.48 V	100	72.2	40.4
6	11000.00	57.3 PK	74.0	-16.7	2.93 V	107	47.6	9.7
7	11000.00	44.5 AV	54.0	-9.5	2.93 V	107	34.8	9.7

Remarks:

1. Emission Level(dBuV/m) = Raw Value(dBuV) + Correction Factor(dB/m)
2. Correction Factor(dB/m) = Antenna Factor(dB/m) + Cable Factor(dB) – Pre-Amplifier Factor(dB)
3. Margin value = Emission Level – Limit value
4. The other emission levels were very low against the limit.
5. " * " : Fundamental frequency, the limit was restricted at the RF Output Power.
6. " # " : The radiated frequency is out of the restricted band.



RF Mode	802.11ax (HE20)	Channel	CH 116 : 5580 MHz
Frequency Range	1 GHz ~ 40 GHz	Detector Function & Bandwidth	PK: RB=1 MHz, VB=3 MHz, DET=Peak AV: RB=1 MHz, VB=1 kHz, DET=Peak
Input Power	120 Vac, 60 Hz	Environmental Conditions	23°C, 67% RH
Tested By	Karl Lee		

Antenna Polarity & Test Distance : Horizontal at 3 m

No	Frequency (MHz)	Emission Level (dBuV/m)	Limit (dBuV/m)	Margin (dB)	Antenna Height (m)	Table Angle (Degree)	Raw Value (dBuV)	Correction Factor (dB/m)
1	*5580.00	117.9 PK			1.49 H	157	76.8	41.1
2	*5580.00	102.7 AV			1.49 H	157	61.6	41.1
3	11160.00	57.6 PK	74.0	-16.4	2.43 H	152	48.2	9.4
4	11160.00	44.8 AV	54.0	-9.2	2.43 H	152	35.4	9.4

Antenna Polarity & Test Distance : Vertical at 3 m

No	Frequency (MHz)	Emission Level (dBuV/m)	Limit (dBuV/m)	Margin (dB)	Antenna Height (m)	Table Angle (Degree)	Raw Value (dBuV)	Correction Factor (dB/m)
1	*5580.00	128.2 PK			1.48 V	100	87.1	41.1
2	*5580.00	113.1 AV			1.48 V	100	72.0	41.1
3	11160.00	57.2 PK	74.0	-16.8	2.21 V	126	47.8	9.4
4	11160.00	44.5 AV	54.0	-9.5	2.21 V	126	35.1	9.4

Remarks:

1. Emission Level(dBuV/m) = Raw Value(dBuV) + Correction Factor(dB/m)
2. Correction Factor(dB/m) = Antenna Factor(dB/m) + Cable Factor(dB) – Pre-Amplifier Factor(dB)
3. Margin value = Emission Level – Limit value
4. The other emission levels were very low against the limit.
5. " * " : Fundamental frequency, the limit was restricted at the RF Output Power.



RF Mode	802.11ax (HE20)	Channel	CH 140 : 5700 MHz
Frequency Range	1 GHz ~ 40 GHz	Detector Function & Bandwidth	PK: RB=1 MHz, VB=3 MHz, DET=Peak AV: RB=1 MHz, VB=1 kHz, DET=Peak
Input Power	120 Vac, 60 Hz	Environmental Conditions	23°C, 67% RH
Tested By	Karl Lee		

Antenna Polarity & Test Distance : Horizontal at 3 m

No	Frequency (MHz)	Emission Level (dBuV/m)	Limit (dBuV/m)	Margin (dB)	Antenna Height (m)	Table Angle (Degree)	Raw Value (dBuV)	Correction Factor (dB/m)
1	*5700.00	115.2 PK			1.42 H	155	73.5	41.7
2	*5700.00	99.5 AV			1.42 H	155	57.8	41.7
3	#5725.00	60.1 PK	68.2	-8.1	1.42 H	155	56.1	4.0
4	11400.00	57.5 PK	74.0	-16.5	1.26 H	51	47.8	9.7
5	11400.00	44.8 AV	54.0	-9.2	1.26 H	51	35.1	9.7

Antenna Polarity & Test Distance : Vertical at 3 m

No	Frequency (MHz)	Emission Level (dBuV/m)	Limit (dBuV/m)	Margin (dB)	Antenna Height (m)	Table Angle (Degree)	Raw Value (dBuV)	Correction Factor (dB/m)
1	*5700.00	126.7 PK			1.56 V	100	85.0	41.7
2	*5700.00	111.8 AV			1.56 V	100	70.1	41.7
3	#5725.00	66.4 PK	68.2	-1.8	1.56 V	100	62.4	4.0
4	11400.00	57.9 PK	74.0	-16.1	1.52 V	146	48.2	9.7
5	11400.00	48.1 AV	54.0	-5.9	1.52 V	146	38.4	9.7

Remarks:

1. Emission Level(dBuV/m) = Raw Value(dBuV) + Correction Factor(dB/m)
2. Correction Factor(dB/m) = Antenna Factor(dB/m) + Cable Factor(dB) – Pre-Amplifier Factor(dB)
3. Margin value = Emission Level – Limit value
4. The other emission levels were very low against the limit.
5. " * ": Fundamental frequency, the limit was restricted at the RF Output Power.
6. " # ": The radiated frequency is out of the restricted band.



RF Mode	802.11ax (HE20)	Channel	CH 144 : 5720 MHz
Frequency Range	1 GHz ~ 40 GHz	Detector Function & Bandwidth	PK: RB=1 MHz, VB=3 MHz, DET=Peak AV: RB=1 MHz, VB=1 kHz, DET=Peak
Input Power	120 Vac, 60 Hz	Environmental Conditions	25°C, 67% RH
Tested By	Karl Lee		

Antenna Polarity & Test Distance : Horizontal at 3 m

No	Frequency (MHz)	Emission Level (dBuV/m)	Limit (dBuV/m)	Margin (dB)	Antenna Height (m)	Table Angle (Degree)	Raw Value (dBuV)	Correction Factor (dB/m)
1	5460.00	57.8 PK	74.0	-16.2	1.92 H	86	55.0	2.8
2	5460.00	45.4 AV	54.0	-8.6	1.92 H	86	42.6	2.8
3	#5470.00	56.9 PK	68.2	-11.3	1.92 H	86	54.1	2.8
4	*5720.00	116.6 PK			1.92 H	86	74.8	41.8
5	*5720.00	102.2 AV			1.92 H	86	60.4	41.8
6	11440.00	57.8 PK	74.0	-16.2	1.61 H	84	48.2	9.6
7	11440.00	45.0 AV	54.0	-9.0	1.61 H	84	35.4	9.6

Antenna Polarity & Test Distance : Vertical at 3 m

No	Frequency (MHz)	Emission Level (dBuV/m)	Limit (dBuV/m)	Margin (dB)	Antenna Height (m)	Table Angle (Degree)	Raw Value (dBuV)	Correction Factor (dB/m)
1	5460.00	59.9 PK	74.0	-14.1	1.85 V	16	57.1	2.8
2	5460.00	46.4 AV	54.0	-7.6	1.85 V	16	43.6	2.8
3	#5470.00	59.1 PK	68.2	-9.1	1.85 V	16	56.3	2.8
4	*5720.00	127.9 PK			1.85 V	16	86.1	41.8
5	*5720.00	113.3 AV			1.85 V	16	71.5	41.8
6	11440.00	58.1 PK	74.0	-15.9	1.56 V	281	48.5	9.6
7	11440.00	45.3 AV	54.0	-8.7	1.56 V	281	35.7	9.6

Remarks:

1. Emission Level(dBuV/m) = Raw Value(dBuV) + Correction Factor(dB/m)
2. Correction Factor(dB/m) = Antenna Factor(dB/m) + Cable Factor(dB) – Pre-Amplifier Factor(dB)
3. Margin value = Emission Level – Limit value
4. The other emission levels were very low against the limit.
5. " * " : Fundamental frequency, the limit was restricted at the RF Output Power.
6. " # " : The radiated frequency is out of the restricted band.



RF Mode	802.11ax (HE40)	Channel	CH 102 : 5510 MHz
Frequency Range	1 GHz ~ 40 GHz	Detector Function & Bandwidth	PK: RB=1 MHz, VB=3 MHz, DET=Peak AV: RB=1 MHz, VB=1 kHz, DET=Peak
Input Power	120 Vac, 60 Hz	Environmental Conditions	23°C, 67% RH
Tested By	Karl Lee		

Antenna Polarity & Test Distance : Horizontal at 3 m

No	Frequency (MHz)	Emission Level (dBuV/m)	Limit (dBuV/m)	Margin (dB)	Antenna Height (m)	Table Angle (Degree)	Raw Value (dBuV)	Correction Factor (dB/m)
1	5460.00	58.7 PK	74.0	-15.3	1.52 H	157	55.9	2.8
2	5460.00	45.9 AV	54.0	-8.1	1.52 H	157	43.1	2.8
3	#5470.00	58.8 PK	68.2	-9.4	1.52 H	157	56.0	2.8
4	*5510.00	113.4 PK			1.52 H	157	73.0	40.4
5	*5510.00	97.9 AV			1.52 H	157	57.5	40.4
6	11020.00	57.5 PK	74.0	-16.5	1.06 H	249	47.8	9.7
7	11020.00	44.7 AV	54.0	-9.3	1.06 H	249	35.0	9.7

Antenna Polarity & Test Distance : Vertical at 3 m

No	Frequency (MHz)	Emission Level (dBuV/m)	Limit (dBuV/m)	Margin (dB)	Antenna Height (m)	Table Angle (Degree)	Raw Value (dBuV)	Correction Factor (dB/m)
1	5460.00	63.3 PK	74.0	-10.7	1.48 V	94	60.5	2.8
2	5460.00	49.7 AV	54.0	-4.3	1.48 V	94	46.9	2.8
3	#5470.00	66.4 PK	68.2	-1.8	1.48 V	94	63.6	2.8
4	*5510.00	123.3 PK			1.48 V	94	82.9	40.4
5	*5510.00	108.2 AV			1.48 V	94	67.8	40.4
6	11020.00	58.1 PK	74.0	-15.9	1.81 V	254	48.4	9.7
7	11020.00	45.4 AV	54.0	-8.6	1.81 V	254	35.7	9.7

Remarks:

1. Emission Level(dBuV/m) = Raw Value(dBuV) + Correction Factor(dB/m)
2. Correction Factor(dB/m) = Antenna Factor(dB/m) + Cable Factor(dB) – Pre-Amplifier Factor(dB)
3. Margin value = Emission Level – Limit value
4. The other emission levels were very low against the limit.
5. " * " : Fundamental frequency, the limit was restricted at the RF Output Power.
6. " # " : The radiated frequency is out of the restricted band.



RF Mode	802.11ax (HE40)	Channel	CH 110 : 5550 MHz
Frequency Range	1 GHz ~ 40 GHz	Detector Function & Bandwidth	PK: RB=1 MHz, VB=3 MHz, DET=Peak AV: RB=1 MHz, VB=1 kHz, DET=Peak
Input Power	120 Vac, 60 Hz	Environmental Conditions	23°C, 67% RH
Tested By	Karl Lee		

Antenna Polarity & Test Distance : Horizontal at 3 m

No	Frequency (MHz)	Emission Level (dBuV/m)	Limit (dBuV/m)	Margin (dB)	Antenna Height (m)	Table Angle (Degree)	Raw Value (dBuV)	Correction Factor (dB/m)
1	*5550.00	113.6 PK			1.52 H	157	72.8	40.8
2	*5550.00	98.1 AV			1.52 H	157	57.3	40.8
3	11100.00	57.2 PK	74.0	-16.8	1.75 H	51	47.6	9.6
4	11100.00	44.5 AV	54.0	-9.5	1.75 H	51	34.9	9.6

Antenna Polarity & Test Distance : Vertical at 3 m

No	Frequency (MHz)	Emission Level (dBuV/m)	Limit (dBuV/m)	Margin (dB)	Antenna Height (m)	Table Angle (Degree)	Raw Value (dBuV)	Correction Factor (dB/m)
1	*5550.00	125.4 PK			1.57 V	96	84.6	40.8
2	*5550.00	110.7 AV			1.57 V	96	69.9	40.8
3	11100.00	57.7 PK	74.0	-16.3	2.92 V	141	48.1	9.6
4	11100.00	44.9 AV	54.0	-9.1	2.92 V	141	35.3	9.6

Remarks:

1. Emission Level(dBuV/m) = Raw Value(dBuV) + Correction Factor(dB/m)
2. Correction Factor(dB/m) = Antenna Factor(dB/m) + Cable Factor(dB) – Pre-Amplifier Factor(dB)
3. Margin value = Emission Level – Limit value
4. The other emission levels were very low against the limit.
5. " * ": Fundamental frequency, the limit was restricted at the RF Output Power.



RF Mode	802.11ax (HE40)	Channel	CH 134 : 5670 MHz
Frequency Range	1 GHz ~ 40 GHz	Detector Function & Bandwidth	PK: RB=1 MHz, VB=3 MHz, DET=Peak AV: RB=1 MHz, VB=1 kHz, DET=Peak
Input Power	120 Vac, 60 Hz	Environmental Conditions	23°C, 67% RH
Tested By	Karl Lee		

Antenna Polarity & Test Distance : Horizontal at 3 m

No	Frequency (MHz)	Emission Level (dBuV/m)	Limit (dBuV/m)	Margin (dB)	Antenna Height (m)	Table Angle (Degree)	Raw Value (dBuV)	Correction Factor (dB/m)
1	5460.00	58.4 PK	74.0	-15.6	1.61 H	91	55.6	2.8
2	5460.00	45.2 AV	54.0	-8.8	1.61 H	91	42.4	2.8
3	#5470.00	57.4 PK	68.2	-10.8	1.61 H	91	54.6	2.8
4	*5670.00	112.7 PK			1.61 H	91	71.1	41.6
5	*5670.00	98.7 AV			1.61 H	91	57.1	41.6
6	#5725.00	60.0 PK	68.2	-8.2	1.61 H	91	56.0	4.0
7	11340.00	57.7 PK	74.0	-16.3	1.62 H	58	48.2	9.5
8	11340.00	45.0 AV	54.0	-9.0	1.62 H	58	35.5	9.5

Antenna Polarity & Test Distance : Vertical at 3 m

No	Frequency (MHz)	Emission Level (dBuV/m)	Limit (dBuV/m)	Margin (dB)	Antenna Height (m)	Table Angle (Degree)	Raw Value (dBuV)	Correction Factor (dB/m)
1	5460.00	60.4 PK	74.0	-13.6	1.52 V	96	57.6	2.8
2	5460.00	47.5 AV	54.0	-6.5	1.52 V	96	44.7	2.8
3	#5470.00	60.2 PK	68.2	-8.0	1.52 V	96	57.4	2.8
4	*5670.00	125.4 PK			1.52 V	96	83.8	41.6
5	*5670.00	110.1 AV			1.52 V	96	68.5	41.6
6	#5725.00	66.4 PK	68.2	-1.8	1.52 V	96	62.4	4.0
7	11340.00	57.3 PK	74.0	-16.7	1.25 V	194	47.8	9.5
8	11340.00	44.6 AV	54.0	-9.4	1.25 V	194	35.1	9.5

Remarks:

1. Emission Level(dBuV/m) = Raw Value(dBuV) + Correction Factor(dB/m)
2. Correction Factor(dB/m) = Antenna Factor(dB/m) + Cable Factor(dB) – Pre-Amplifier Factor(dB)
3. Margin value = Emission Level – Limit value
4. The other emission levels were very low against the limit.
5. " * " : Fundamental frequency, the limit was restricted at the RF Output Power.
6. " # " : The radiated frequency is out of the restricted band.



RF Mode	802.11ax (HE40)	Channel	CH 142 : 5710 MHz
Frequency Range	1 GHz ~ 40 GHz	Detector Function & Bandwidth	PK: RB=1 MHz, VB=3 MHz, DET=Peak AV: RB=1 MHz, VB=1 kHz, DET=Peak
Input Power	120 Vac, 60 Hz	Environmental Conditions	25°C, 67% RH
Tested By	Karl Lee		

Antenna Polarity & Test Distance : Horizontal at 3 m

No	Frequency (MHz)	Emission Level (dBuV/m)	Limit (dBuV/m)	Margin (dB)	Antenna Height (m)	Table Angle (Degree)	Raw Value (dBuV)	Correction Factor (dB/m)
1	5460.00	57.8 PK	74.0	-16.2	1.92 H	86	55.0	2.8
2	5460.00	45.2 AV	54.0	-8.8	1.92 H	86	42.4	2.8
3	#5470.00	57.6 PK	68.2	-10.6	1.92 H	86	54.8	2.8
4	*5710.00	114.5 PK			1.92 H	86	72.7	41.8
5	*5710.00	99.8 AV			1.92 H	86	58.0	41.8
6	11420.00	57.8 PK	74.0	-16.2	1.34 H	84	48.1	9.7
7	11420.00	45.1 AV	54.0	-8.9	1.34 H	84	35.4	9.7

Antenna Polarity & Test Distance : Vertical at 3 m

No	Frequency (MHz)	Emission Level (dBuV/m)	Limit (dBuV/m)	Margin (dB)	Antenna Height (m)	Table Angle (Degree)	Raw Value (dBuV)	Correction Factor (dB/m)
1	5460.00	59.5 PK	74.0	-14.5	1.85 V	18	56.7	2.8
2	5460.00	46.7 AV	54.0	-7.3	1.85 V	18	43.9	2.8
3	#5470.00	59.2 PK	68.2	-9.0	1.85 V	18	56.4	2.8
4	*5710.00	126.1 PK			1.85 V	18	84.3	41.8
5	*5710.00	111.3 AV			1.85 V	18	69.5	41.8
6	11420.00	57.3 PK	74.0	-16.7	2.11 V	353	47.6	9.7
7	11420.00	44.5 AV	54.0	-9.5	2.11 V	353	34.8	9.7

Remarks:

1. Emission Level(dBuV/m) = Raw Value(dBuV) + Correction Factor(dB/m)
2. Correction Factor(dB/m) = Antenna Factor(dB/m) + Cable Factor(dB) – Pre-Amplifier Factor(dB)
3. Margin value = Emission Level – Limit value
4. The other emission levels were very low against the limit.
5. " * " : Fundamental frequency, the limit was restricted at the RF Output Power.
6. " # " : The radiated frequency is out of the restricted band.



RF Mode	802.11ax (HE80)	Channel	CH 106 : 5530 MHz
Frequency Range	1 GHz ~ 40 GHz	Detector Function & Bandwidth	PK: RB=1 MHz, VB=3 MHz, DET=Peak AV: RB=1 MHz, VB=1 kHz, DET=Peak
Input Power	120 Vac, 60 Hz	Environmental Conditions	23°C, 67% RH
Tested By	Karl Lee		

Antenna Polarity & Test Distance : Horizontal at 3 m

No	Frequency (MHz)	Emission Level (dBuV/m)	Limit (dBuV/m)	Margin (dB)	Antenna Height (m)	Table Angle (Degree)	Raw Value (dBuV)	Correction Factor (dB/m)
1	5460.00	60.4 PK	74.0	-13.6	1.52 H	157	57.6	2.8
2	5460.00	47.6 AV	54.0	-6.4	1.52 H	157	44.8	2.8
3	#5470.00	60.1 PK	68.2	-8.1	1.52 H	157	57.3	2.8
4	*5530.00	106.4 PK			1.52 H	157	65.7	40.7
5	*5530.00	91.3 AV			1.52 H	157	50.6	40.7
6	#5725.00	59.9 PK	68.2	-8.3	1.52 H	157	55.9	4.0
7	11060.00	57.4 PK	74.0	-16.6	1.78 H	175	47.8	9.6
8	11060.00	44.7 AV	54.0	-9.3	1.78 H	175	35.1	9.6

Antenna Polarity & Test Distance : Vertical at 3 m

No	Frequency (MHz)	Emission Level (dBuV/m)	Limit (dBuV/m)	Margin (dB)	Antenna Height (m)	Table Angle (Degree)	Raw Value (dBuV)	Correction Factor (dB/m)
1	5460.00	66.7 PK	74.0	-7.3	1.60 V	96	63.9	2.8
2	5460.00	53.6 AV	54.0	-0.4	1.60 V	96	50.8	2.8
3	#5470.00	67.7 PK	68.2	-0.5	1.60 V	96	64.9	2.8
4	*5530.00	117.4 PK			1.60 V	96	76.7	40.7
5	*5530.00	102.3 AV			1.60 V	96	61.6	40.7
6	#5725.00	60.8 PK	68.2	-7.4	1.60 V	96	56.8	4.0
7	11060.00	57.8 PK	74.0	-16.2	2.53 V	144	48.2	9.6
8	11060.00	45.0 AV	54.0	-9.0	2.53 V	144	35.4	9.6

Remarks:

1. Emission Level(dBuV/m) = Raw Value(dBuV) + Correction Factor(dB/m)
2. Correction Factor(dB/m) = Antenna Factor(dB/m) + Cable Factor(dB) – Pre-Amplifier Factor(dB)
3. Margin value = Emission Level – Limit value
4. The other emission levels were very low against the limit.
5. " * " : Fundamental frequency, the limit was restricted at the RF Output Power.
6. " # " : The radiated frequency is out of the restricted band.



RF Mode	802.11ax (HE80)	Channel	CH 122 : 5610 MHz
Frequency Range	1 GHz ~ 40 GHz	Detector Function & Bandwidth	PK: RB=1 MHz, VB=3 MHz, DET=Peak AV: RB=1 MHz, VB=1 kHz, DET=Peak
Input Power	120 Vac, 60 Hz	Environmental Conditions	23°C, 67% RH
Tested By	Karl Lee		

Antenna Polarity & Test Distance : Horizontal at 3 m

No	Frequency (MHz)	Emission Level (dBuV/m)	Limit (dBuV/m)	Margin (dB)	Antenna Height (m)	Table Angle (Degree)	Raw Value (dBuV)	Correction Factor (dB/m)
1	5460.00	59.5 PK	74.0	-14.5	1.51 H	155	56.7	2.8
2	5460.00	45.5 AV	54.0	-8.5	1.51 H	155	42.7	2.8
3	#5470.00	58.7 PK	68.2	-9.5	1.51 H	155	55.9	2.8
4	*5610.00	109.6 PK			1.51 H	155	68.3	41.3
5	*5610.00	94.8 AV			1.51 H	155	53.5	41.3
6	#5725.00	60.7 PK	68.2	-7.5	1.51 H	155	56.7	4.0
7	11220.00	56.7 PK	74.0	-17.3	2.11 H	249	47.6	9.1
8	11220.00	44.0 AV	54.0	-10.0	2.11 H	249	34.9	9.1

Antenna Polarity & Test Distance : Vertical at 3 m

No	Frequency (MHz)	Emission Level (dBuV/m)	Limit (dBuV/m)	Margin (dB)	Antenna Height (m)	Table Angle (Degree)	Raw Value (dBuV)	Correction Factor (dB/m)
1	5460.00	61.4 PK	74.0	-12.6	1.55 V	95	58.6	2.8
2	5460.00	48.6 AV	54.0	-5.4	1.55 V	95	45.8	2.8
3	#5470.00	61.0 PK	68.2	-7.2	1.55 V	95	58.2	2.8
4	*5610.00	122.3 PK			1.55 V	95	81.0	41.3
5	*5610.00	107.3 AV			1.55 V	95	66.0	41.3
6	#5725.00	65.3 PK	68.2	-2.9	1.55 V	95	61.3	4.0
7	11220.00	57.4 PK	74.0	-16.6	2.95 V	105	48.3	9.1
8	11220.00	44.7 AV	54.0	-9.3	2.95 V	105	35.6	9.1

Remarks:

1. Emission Level(dBuV/m) = Raw Value(dBuV) + Correction Factor(dB/m)
2. Correction Factor(dB/m) = Antenna Factor(dB/m) + Cable Factor(dB) – Pre-Amplifier Factor(dB)
3. Margin value = Emission Level – Limit value
4. The other emission levels were very low against the limit.
5. " * " : Fundamental frequency, the limit was restricted at the RF Output Power.
6. " # " : The radiated frequency is out of the restricted band.



RF Mode	802.11ax (HE80)	Channel	CH 138 : 5690 MHz
Frequency Range	1 GHz ~ 40 GHz	Detector Function & Bandwidth	PK: RB=1 MHz, VB=3 MHz, DET=Peak AV: RB=1 MHz, VB=1 kHz, DET=Peak
Input Power	120 Vac, 60 Hz	Environmental Conditions	25°C, 67% RH
Tested By	Karl Lee		

Antenna Polarity & Test Distance : Horizontal at 3 m

No	Frequency (MHz)	Emission Level (dBuV/m)	Limit (dBuV/m)	Margin (dB)	Antenna Height (m)	Table Angle (Degree)	Raw Value (dBuV)	Correction Factor (dB/m)
1	5460.00	58.6 PK	74.0	-15.4	1.92 H	86	55.8	2.8
2	5460.00	45.3 AV	54.0	-8.7	1.92 H	86	42.5	2.8
3	#5470.00	57.9 PK	68.2	-10.3	1.92 H	86	55.1	2.8
4	*5690.00	110.0 PK			1.92 H	86	68.3	41.7
5	*5690.00	95.8 AV			1.92 H	86	54.1	41.7
6	#5850.00	59.7 PK	68.2	-8.5	1.92 H	86	55.3	4.4
7	11380.00	57.5 PK	74.0	-16.5	1.26 H	48	47.8	9.7
8	11380.00	44.6 AV	54.0	-9.4	1.26 H	48	34.9	9.7

Antenna Polarity & Test Distance : Vertical at 3 m

No	Frequency (MHz)	Emission Level (dBuV/m)	Limit (dBuV/m)	Margin (dB)	Antenna Height (m)	Table Angle (Degree)	Raw Value (dBuV)	Correction Factor (dB/m)
1	5460.00	60.6 PK	74.0	-13.4	1.82 V	24	57.8	2.8
2	5460.00	47.2 AV	54.0	-6.8	1.82 V	24	44.4	2.8
3	#5470.00	59.8 PK	68.2	-8.4	1.82 V	24	57.0	2.8
4	*5690.00	122.2 PK			1.82 V	24	80.5	41.7
5	*5690.00	106.8 AV			1.82 V	24	65.1	41.7
6	#5850.00	67.9 PK	68.2	-0.3	1.82 V	24	63.5	4.4
7	11380.00	58.0 PK	74.0	-16.0	1.88 V	314	48.3	9.7
8	11380.00	45.3 AV	54.0	-8.7	1.88 V	314	35.6	9.7

Remarks:

1. Emission Level(dBuV/m) = Raw Value(dBuV) + Correction Factor(dB/m)
2. Correction Factor(dB/m) = Antenna Factor(dB/m) + Cable Factor(dB) – Pre-Amplifier Factor(dB)
3. Margin value = Emission Level – Limit value
4. The other emission levels were very low against the limit.
5. " * " : Fundamental frequency, the limit was restricted at the RF Output Power.
6. " # " : The radiated frequency is out of the restricted band.



RF Mode	802.11a	Channel	CH 149 : 5745 MHz
Frequency Range	1 GHz ~ 40 GHz	Detector Function & Bandwidth	PK: RB=1 MHz, VB=3 MHz, DET=Peak AV: RB=1 MHz, VB=1 kHz, DET=Peak
Input Power	120 Vac, 60 Hz	Environmental Conditions	21°C, 68% RH
Tested By	Karl Lee		

Antenna Polarity & Test Distance : Horizontal at 3 m

No	Frequency (MHz)	Emission Level (dBuV/m)	Limit (dBuV/m)	Margin (dB)	Antenna Height (m)	Table Angle (Degree)	Raw Value (dBuV)	Correction Factor (dB/m)
1	#5627.60	61.1 PK	68.2	-7.1	1.00 H	318	58.2	2.9
2	*5745.00	113.5 PK			1.00 H	318	71.8	41.7
3	*5745.00	104.5 AV			1.00 H	318	62.8	41.7
4	#5935.60	62.4 PK	68.2	-5.8	1.00 H	318	59.0	3.4
5	11490.00	58.6 PK	74.0	-15.4	1.53 H	23	49.6	9.0
6	11490.00	50.4 AV	54.0	-3.6	1.53 H	23	41.4	9.0

Antenna Polarity & Test Distance : Vertical at 3 m

No	Frequency (MHz)	Emission Level (dBuV/m)	Limit (dBuV/m)	Margin (dB)	Antenna Height (m)	Table Angle (Degree)	Raw Value (dBuV)	Correction Factor (dB/m)
1	#5627.20	62.8 PK	68.2	-5.4	1.80 V	98	59.9	2.9
2	*5745.00	127.7 PK			1.80 V	98	86.0	41.7
3	*5745.00	118.1 AV			1.80 V	98	76.4	41.7
4	#5952.40	62.8 PK	68.2	-5.4	1.80 V	98	59.4	3.4
5	11490.00	57.9 PK	74.0	-16.1	1.71 V	37	48.9	9.0
6	11490.00	47.9 AV	54.0	-6.1	1.71 V	37	38.9	9.0

Remarks:

1. Emission Level(dBuV/m) = Raw Value(dBuV) + Correction Factor(dB/m)
2. Correction Factor(dB/m) = Antenna Factor(dB/m) + Cable Factor(dB) – Pre-Amplifier Factor(dB)
3. Margin value = Emission Level – Limit value
4. The other emission levels were very low against the limit.
5. " * ": Fundamental frequency, the limit was restricted at the RF Output Power.



RF Mode	802.11a	Channel	CH 157 : 5785 MHz
Frequency Range	1 GHz ~ 40 GHz	Detector Function & Bandwidth	PK: RB=1 MHz, VB=3 MHz, DET=Peak AV: RB=1 MHz, VB=1 kHz, DET=Peak
Input Power	120 Vac, 60 Hz	Environmental Conditions	21°C, 68% RH
Tested By	Karl Lee		

Antenna Polarity & Test Distance : Horizontal at 3 m

No	Frequency (MHz)	Emission Level (dBUV/m)	Limit (dBUV/m)	Margin (dB)	Antenna Height (m)	Table Angle (Degree)	Raw Value (dBUV)	Correction Factor (dB/m)
1	#5601.20	62.8 PK	68.2	-5.4	1.69 H	269	60.2	2.6
2	*5785.00	116.1 PK			1.69 H	269	74.3	41.8
3	*5785.00	106.5 AV			1.69 H	269	64.7	41.8
4	#5967.60	63.5 PK	68.2	-4.7	1.69 H	269	60.1	3.4
5	11570.00	60.1 PK	74.0	-13.9	1.60 H	356	51.2	8.9
6	11570.00	49.6 AV	54.0	-4.4	1.60 H	356	40.7	8.9

Antenna Polarity & Test Distance : Vertical at 3 m

No	Frequency (MHz)	Emission Level (dBUV/m)	Limit (dBUV/m)	Margin (dB)	Antenna Height (m)	Table Angle (Degree)	Raw Value (dBUV)	Correction Factor (dB/m)
1	#5641.60	63.7 PK	68.2	-4.5	1.80 V	108	60.7	3.0
2	*5785.00	129.1 PK			1.80 V	108	87.3	41.8
3	*5785.00	119.3 AV			1.80 V	108	77.5	41.8
4	#5978.40	64.0 PK	68.2	-4.2	1.80 V	108	60.7	3.3
5	11570.00	59.2 PK	74.0	-14.8	2.19 V	341	50.3	8.9
6	11570.00	48.1 AV	54.0	-5.9	2.19 V	341	39.2	8.9

Remarks:

1. Emission Level(dBUV/m) = Raw Value(dBUV) + Correction Factor(dB/m)
2. Correction Factor(dB/m) = Antenna Factor(dB/m) + Cable Factor(dB) – Pre-Amplifier Factor(dB)
3. Margin value = Emission Level – Limit value
4. The other emission levels were very low against the limit.
5. " * " : Fundamental frequency, the limit was restricted at the RF Output Power.
6. " # " : The radiated frequency is out of the restricted band.



RF Mode	802.11a	Channel	CH 165 : 5825 MHz
Frequency Range	1 GHz ~ 40 GHz	Detector Function & Bandwidth	PK: RB=1 MHz, VB=3 MHz, DET=Peak AV: RB=1 MHz, VB=1 kHz, DET=Peak
Input Power	120 Vac, 60 Hz	Environmental Conditions	21°C, 68% RH
Tested By	Karl Lee		

Antenna Polarity & Test Distance : Horizontal at 3 m

No	Frequency (MHz)	Emission Level (dBUV/m)	Limit (dBUV/m)	Margin (dB)	Antenna Height (m)	Table Angle (Degree)	Raw Value (dBUV)	Correction Factor (dB/m)
1	#5638.80	62.0 PK	68.2	-6.2	1.69 H	267	59.0	3.0
2	*5825.00	114.9 PK			1.69 H	267	73.1	41.8
3	*5825.00	104.6 AV			1.69 H	267	62.8	41.8
4	#5965.20	62.9 PK	68.2	-5.3	1.69 H	267	59.5	3.4
5	11650.00	59.7 PK	74.0	-14.3	1.76 H	335	50.9	8.8
6	11650.00	52.2 AV	54.0	-1.8	1.76 H	335	43.4	8.8

Antenna Polarity & Test Distance : Vertical at 3 m

No	Frequency (MHz)	Emission Level (dBUV/m)	Limit (dBUV/m)	Margin (dB)	Antenna Height (m)	Table Angle (Degree)	Raw Value (dBUV)	Correction Factor (dB/m)
1	#5626.80	63.4 PK	68.2	-4.8	1.74 V	110	60.5	2.9
2	*5825.00	127.9 PK			1.74 V	110	86.1	41.8
3	*5825.00	117.8 AV			1.74 V	110	76.0	41.8
4	#5967.20	63.5 PK	68.2	-4.7	1.74 V	110	60.1	3.4
5	11650.00	58.7 PK	74.0	-15.3	1.53 V	332	49.9	8.8
6	11650.00	47.5 AV	54.0	-6.5	1.53 V	332	38.7	8.8

Remarks:

1. Emission Level(dBUV/m) = Raw Value(dBUV) + Correction Factor(dB/m)
2. Correction Factor(dB/m) = Antenna Factor(dB/m) + Cable Factor(dB) – Pre-Amplifier Factor(dB)
3. Margin value = Emission Level – Limit value
4. The other emission levels were very low against the limit.
5. " * " : Fundamental frequency, the limit was restricted at the RF Output Power.
6. " # " : The radiated frequency is out of the restricted band.



RF Mode	802.11ax (HE20)	Channel	CH 149 : 5745 MHz
Frequency Range	1 GHz ~ 40 GHz	Detector Function & Bandwidth	PK: RB=1 MHz, VB=3 MHz, DET=Peak AV: RB=1 MHz, VB=1 kHz, DET=Peak
Input Power	120 Vac, 60 Hz	Environmental Conditions	21°C, 68% RH
Tested By	Karl Lee		

Antenna Polarity & Test Distance : Horizontal at 3 m

No	Frequency (MHz)	Emission Level (dBuV/m)	Limit (dBuV/m)	Margin (dB)	Antenna Height (m)	Table Angle (Degree)	Raw Value (dBuV)	Correction Factor (dB/m)
1	#5603.20	60.7 PK	68.2	-7.5	1.67 H	265	58.1	2.6
2	*5745.00	116.8 PK			1.67 H	265	75.1	41.7
3	*5745.00	105.5 AV			1.67 H	265	63.8	41.7
4	#5993.20	62.9 PK	68.2	-5.3	1.67 H	265	59.5	3.4
5	11490.00	59.2 PK	74.0	-14.8	1.58 H	355	50.2	9.0
6	11490.00	50.6 AV	54.0	-3.4	1.58 H	355	41.6	9.0

Antenna Polarity & Test Distance : Vertical at 3 m

No	Frequency (MHz)	Emission Level (dBuV/m)	Limit (dBuV/m)	Margin (dB)	Antenna Height (m)	Table Angle (Degree)	Raw Value (dBuV)	Correction Factor (dB/m)
1	#5641.60	62.9 PK	68.2	-5.3	1.81 V	91	59.9	3.0
2	*5745.00	129.6 PK			1.81 V	91	87.9	41.7
3	*5745.00	117.9 AV			1.81 V	91	76.2	41.7
4	#5944.80	62.5 PK	68.2	-5.7	1.81 V	91	59.1	3.4
5	11490.00	58.0 PK	74.0	-16.0	1.85 V	58	49.0	9.0
6	11490.00	47.1 AV	54.0	-6.9	1.85 V	58	38.1	9.0

Remarks:

1. Emission Level(dBuV/m) = Raw Value(dBuV) + Correction Factor(dB/m)
2. Correction Factor(dB/m) = Antenna Factor(dB/m) + Cable Factor(dB) – Pre-Amplifier Factor(dB)
3. Margin value = Emission Level – Limit value
4. The other emission levels were very low against the limit.
5. " * " : Fundamental frequency, the limit was restricted at the RF Output Power.
6. " # " : The radiated frequency is out of the restricted band.



RF Mode	802.11ax (HE20)	Channel	CH 157 : 5785 MHz
Frequency Range	1 GHz ~ 40 GHz	Detector Function & Bandwidth	PK: RB=1 MHz, VB=3 MHz, DET=Peak AV: RB=1 MHz, VB=1 kHz, DET=Peak
Input Power	120 Vac, 60 Hz	Environmental Conditions	21°C, 68% RH
Tested By	Karl Lee		

Antenna Polarity & Test Distance : Horizontal at 3 m

No	Frequency (MHz)	Emission Level (dBuV/m)	Limit (dBuV/m)	Margin (dB)	Antenna Height (m)	Table Angle (Degree)	Raw Value (dBuV)	Correction Factor (dB/m)
1	#5642.80	62.5 PK	68.2	-5.7	1.70 H	266	59.5	3.0
2	*5785.00	114.6 PK			1.70 H	266	72.8	41.8
3	*5785.00	105.0 AV			1.70 H	266	63.2	41.8
4	#5952.80	63.3 PK	68.2	-4.9	1.70 H	266	59.9	3.4
5	11570.00	59.0 PK	74.0	-15.0	1.26 H	34	50.1	8.9
6	11570.00	48.9 AV	54.0	-5.1	1.26 H	34	40.0	8.9

Antenna Polarity & Test Distance : Vertical at 3 m

No	Frequency (MHz)	Emission Level (dBuV/m)	Limit (dBuV/m)	Margin (dB)	Antenna Height (m)	Table Angle (Degree)	Raw Value (dBuV)	Correction Factor (dB/m)
1	#5600.00	62.9 PK	68.2	-5.3	1.84 V	106	60.3	2.6
2	*5785.00	128.7 PK			1.84 V	106	86.9	41.8
3	*5785.00	118.2 AV			1.84 V	106	76.4	41.8
4	#5995.60	63.2 PK	68.2	-5.0	1.84 V	106	59.8	3.4
5	11570.00	58.5 PK	74.0	-15.5	1.72 V	32	49.6	8.9
6	11570.00	48.0 AV	54.0	-6.0	1.72 V	32	39.1	8.9

Remarks:

1. Emission Level(dBuV/m) = Raw Value(dBuV) + Correction Factor(dB/m)
2. Correction Factor(dB/m) = Antenna Factor(dB/m) + Cable Factor(dB) – Pre-Amplifier Factor(dB)
3. Margin value = Emission Level – Limit value
4. The other emission levels were very low against the limit.
5. " * " : Fundamental frequency, the limit was restricted at the RF Output Power.
6. " # " : The radiated frequency is out of the restricted band.



RF Mode	802.11ax (HE20)	Channel	CH 165 : 5825 MHz
Frequency Range	1 GHz ~ 40 GHz	Detector Function & Bandwidth	PK: RB=1 MHz, VB=3 MHz, DET=Peak AV: RB=1 MHz, VB=1 kHz, DET=Peak
Input Power	120 Vac, 60 Hz	Environmental Conditions	21°C, 68% RH
Tested By	Karl Lee		

Antenna Polarity & Test Distance : Horizontal at 3 m

No	Frequency (MHz)	Emission Level (dBuV/m)	Limit (dBuV/m)	Margin (dB)	Antenna Height (m)	Table Angle (Degree)	Raw Value (dBuV)	Correction Factor (dB/m)
1	#5648.80	61.6 PK	68.2	-6.6	1.66 H	267	58.5	3.1
2	*5825.00	116.0 PK			1.66 H	267	74.2	41.8
3	*5825.00	104.6 AV			1.66 H	267	62.8	41.8
4	#5937.60	63.3 PK	68.2	-4.9	1.66 H	267	59.9	3.4
5	11650.00	60.0 PK	74.0	-14.0	1.75 H	334	51.2	8.8
6	11650.00	52.4 AV	54.0	-1.6	1.75 H	334	43.6	8.8

Antenna Polarity & Test Distance : Vertical at 3 m

No	Frequency (MHz)	Emission Level (dBuV/m)	Limit (dBuV/m)	Margin (dB)	Antenna Height (m)	Table Angle (Degree)	Raw Value (dBuV)	Correction Factor (dB/m)
1	#5639.20	63.5 PK	68.2	-4.7	1.86 V	105	60.5	3.0
2	*5825.00	128.8 PK			1.86 V	105	87.0	41.8
3	*5825.00	117.5 AV			1.86 V	105	75.7	41.8
4	#5964.00	63.9 PK	68.2	-4.3	1.86 V	105	60.5	3.4
5	11650.00	58.2 PK	74.0	-15.8	1.48 V	331	49.4	8.8
6	11650.00	48.3 AV	54.0	-5.7	1.48 V	331	39.5	8.8

Remarks:

1. Emission Level(dBuV/m) = Raw Value(dBuV) + Correction Factor(dB/m)
2. Correction Factor(dB/m) = Antenna Factor(dB/m) + Cable Factor(dB) – Pre-Amplifier Factor(dB)
3. Margin value = Emission Level – Limit value
4. The other emission levels were very low against the limit.
5. " * " : Fundamental frequency, the limit was restricted at the RF Output Power.
6. " # " : The radiated frequency is out of the restricted band.



RF Mode	802.11ax (HE40)	Channel	CH 151 : 5755 MHz
Frequency Range	1 GHz ~ 40 GHz	Detector Function & Bandwidth	PK: RB=1 MHz, VB=3 MHz, DET=Peak AV: RB=1 MHz, VB=1 kHz, DET=Peak
Input Power	120 Vac, 60 Hz	Environmental Conditions	21°C, 68% RH
Tested By	Karl Lee		

Antenna Polarity & Test Distance : Horizontal at 3 m

No	Frequency (MHz)	Emission Level (dBuV/m)	Limit (dBuV/m)	Margin (dB)	Antenna Height (m)	Table Angle (Degree)	Raw Value (dBuV)	Correction Factor (dB/m)
1	#5626.00	61.3 PK	68.2	-6.9	1.67 H	314	58.4	2.9
2	*5755.00	111.4 PK			1.67 H	314	69.7	41.7
3	*5755.00	101.8 AV			1.67 H	314	60.1	41.7
4	#5991.60	62.3 PK	68.2	-5.9	1.67 H	314	58.9	3.4
5	11510.00	59.6 PK	74.0	-14.4	1.63 H	355	50.6	9.0
6	11510.00	51.1 AV	54.0	-2.9	1.63 H	355	42.1	9.0

Antenna Polarity & Test Distance : Vertical at 3 m

No	Frequency (MHz)	Emission Level (dBuV/m)	Limit (dBuV/m)	Margin (dB)	Antenna Height (m)	Table Angle (Degree)	Raw Value (dBuV)	Correction Factor (dB/m)
1	#5642.80	67.7 PK	68.2	-0.5	1.83 V	93	64.7	3.0
2	*5755.00	125.3 PK			1.83 V	93	83.6	41.7
3	*5755.00	115.2 AV			1.83 V	93	73.5	41.7
4	#5956.00	64.5 PK	68.2	-3.7	1.83 V	93	61.1	3.4
5	11510.00	57.6 PK	74.0	-16.4	1.45 V	55	48.6	9.0
6	11510.00	47.3 AV	54.0	-6.7	1.45 V	55	38.3	9.0

Remarks:

1. Emission Level(dBuV/m) = Raw Value(dBuV) + Correction Factor(dB/m)
2. Correction Factor(dB/m) = Antenna Factor(dB/m) + Cable Factor(dB) – Pre-Amplifier Factor(dB)
3. Margin value = Emission Level – Limit value
4. The other emission levels were very low against the limit.
5. " * " : Fundamental frequency, the limit was restricted at the RF Output Power.
6. " # " : The radiated frequency is out of the restricted band.



RF Mode	802.11ax (HE40)	Channel	CH 159 : 5795 MHz
Frequency Range	1 GHz ~ 40 GHz	Detector Function & Bandwidth	PK: RB=1 MHz, VB=3 MHz, DET=Peak AV: RB=1 MHz, VB=1 kHz, DET=Peak
Input Power	120 Vac, 60 Hz	Environmental Conditions	21°C, 68% RH
Tested By	Karl Lee		

Antenna Polarity & Test Distance : Horizontal at 3 m

No	Frequency (MHz)	Emission Level (dBuV/m)	Limit (dBuV/m)	Margin (dB)	Antenna Height (m)	Table Angle (Degree)	Raw Value (dBuV)	Correction Factor (dB/m)
1	#5646.40	61.2 PK	68.2	-7.0	1.68 H	268	58.2	3.0
2	*5795.00	112.6 PK			1.68 H	268	70.8	41.8
3	*5795.00	102.2 AV			1.68 H	268	60.4	41.8
4	#5962.00	62.4 PK	68.2	-5.8	1.68 H	268	59.0	3.4
5	11590.00	58.5 PK	74.0	-15.5	1.63 H	358	49.6	8.9
6	11590.00	50.3 AV	54.0	-3.7	1.63 H	358	41.4	8.9

Antenna Polarity & Test Distance : Vertical at 3 m

No	Frequency (MHz)	Emission Level (dBuV/m)	Limit (dBuV/m)	Margin (dB)	Antenna Height (m)	Table Angle (Degree)	Raw Value (dBuV)	Correction Factor (dB/m)
1	#5616.80	64.0 PK	68.2	-4.2	1.87 V	96	61.3	2.7
2	*5795.00	124.9 PK			1.87 V	96	83.1	41.8
3	*5795.00	115.1 AV			1.87 V	96	73.3	41.8
4	#5997.20	64.3 PK	68.2	-3.9	1.87 V	96	60.9	3.4
5	11590.00	58.6 PK	74.0	-15.4	1.47 V	34	49.7	8.9
6	11590.00	48.0 AV	54.0	-6.0	1.47 V	34	39.1	8.9

Remarks:

1. Emission Level(dBuV/m) = Raw Value(dBuV) + Correction Factor(dB/m)
2. Correction Factor(dB/m) = Antenna Factor(dB/m) + Cable Factor(dB) – Pre-Amplifier Factor(dB)
3. Margin value = Emission Level – Limit value
4. The other emission levels were very low against the limit.
5. " * " : Fundamental frequency, the limit was restricted at the RF Output Power.
6. " # " : The radiated frequency is out of the restricted band.



RF Mode	802.11ax (HE80)	Channel	CH 155 : 5775 MHz
Frequency Range	1 GHz ~ 40 GHz	Detector Function & Bandwidth	PK: RB=1 MHz, VB=3 MHz, DET=Peak AV: RB=1 MHz, VB=1 kHz, DET=Peak
Input Power	120 Vac, 60 Hz	Environmental Conditions	21°C, 68% RH
Tested By	Karl Lee		

Antenna Polarity & Test Distance : Horizontal at 3 m

No	Frequency (MHz)	Emission Level (dBuV/m)	Limit (dBuV/m)	Margin (dB)	Antenna Height (m)	Table Angle (Degree)	Raw Value (dBuV)	Correction Factor (dB/m)
1	#5644.40	62.9 PK	68.2	-5.3	1.73 H	268	59.9	3.0
2	*5775.00	106.2 PK			1.73 H	268	64.4	41.8
3	*5775.00	96.8 AV			1.73 H	268	55.0	41.8
4	#5963.60	62.6 PK	68.2	-5.6	1.73 H	268	59.2	3.4
5	11550.00	59.0 PK	74.0	-15.0	1.62 H	356	50.1	8.9
6	11550.00	49.8 AV	54.0	-4.2	1.62 H	356	40.9	8.9

Antenna Polarity & Test Distance : Vertical at 3 m

No	Frequency (MHz)	Emission Level (dBuV/m)	Limit (dBuV/m)	Margin (dB)	Antenna Height (m)	Table Angle (Degree)	Raw Value (dBuV)	Correction Factor (dB/m)
1	#5648.40	67.9 PK	68.2	-0.3	1.65 V	107	64.8	3.1
2	*5775.00	117.7 PK			1.65 V	107	75.9	41.8
3	*5775.00	109.5 AV			1.65 V	107	67.7	41.8
4	#5927.60	67.4 PK	68.2	-0.8	1.65 V	107	64.1	3.3
5	11550.00	57.8 PK	74.0	-16.2	1.47 V	57	48.9	8.9
6	11550.00	47.4 AV	54.0	-6.6	1.47 V	57	38.5	8.9

Remarks:

1. Emission Level(dBuV/m) = Raw Value(dBuV) + Correction Factor(dB/m)
2. Correction Factor(dB/m) = Antenna Factor(dB/m) + Cable Factor(dB) – Pre-Amplifier Factor(dB)
3. Margin value = Emission Level – Limit value
4. The other emission levels were very low against the limit.
5. " * " : Fundamental frequency, the limit was restricted at the RF Output Power.
6. " # " : The radiated frequency is out of the restricted band.

Frequency Range	4.5 GHz ~ 5.46 GHz	Detector Function & Bandwidth	PK: RB=1 MHz, VB=3 MHz, DET=Peak AV: RB=1 MHz, VB=1 kHz, DET=Peak
-----------------	--------------------	-------------------------------	--

802.11a Channel 36

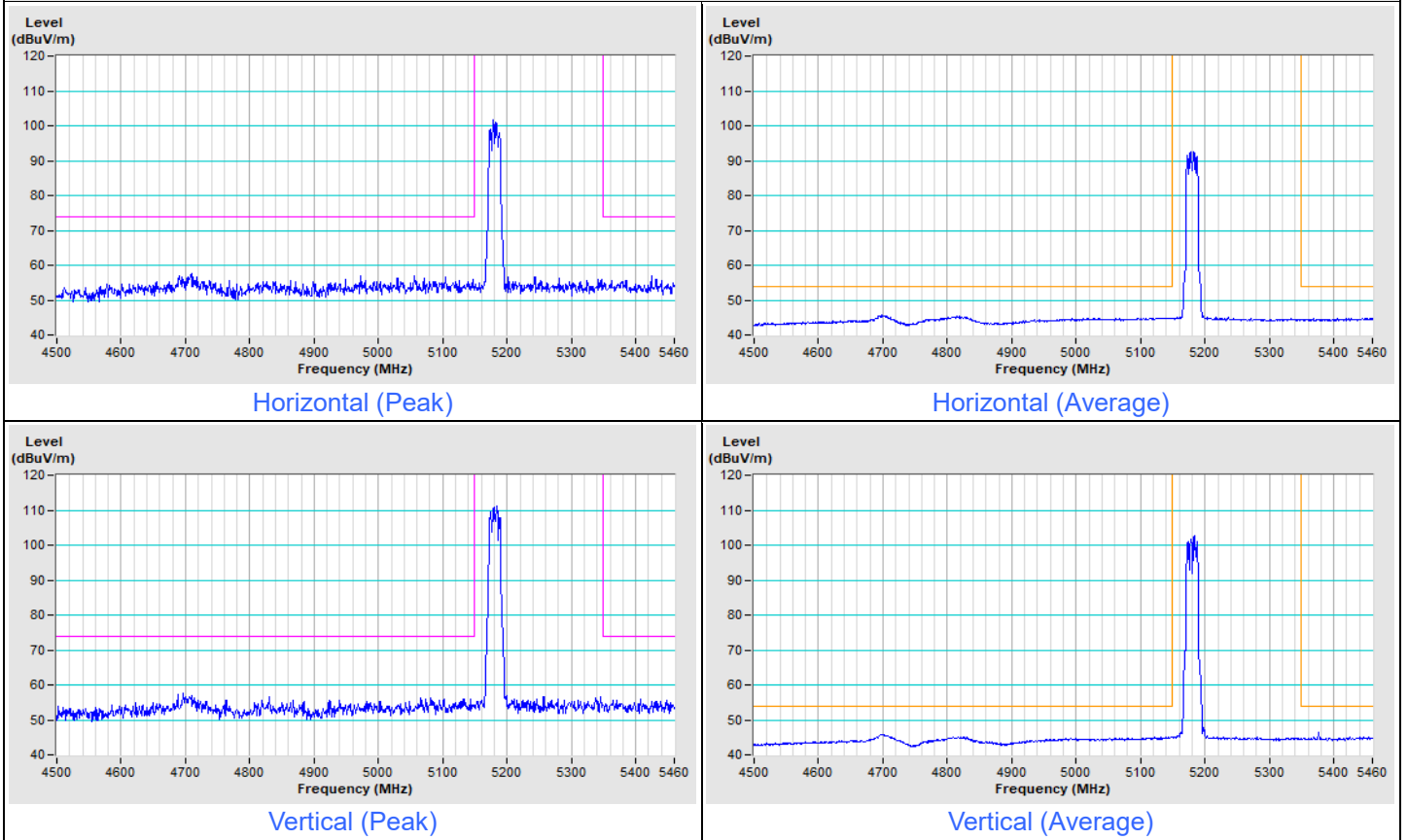

802.11a Channel 48

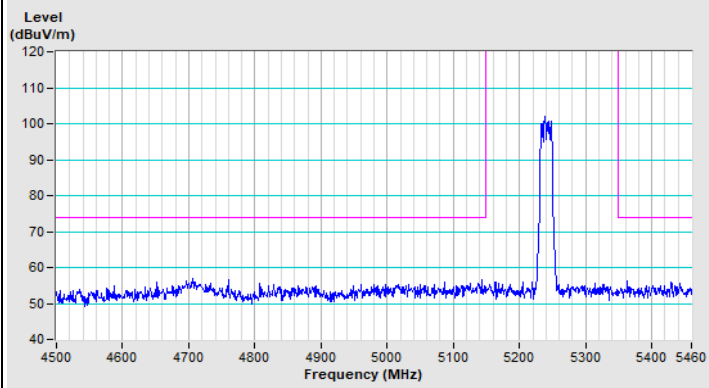

Horizontal (Peak)

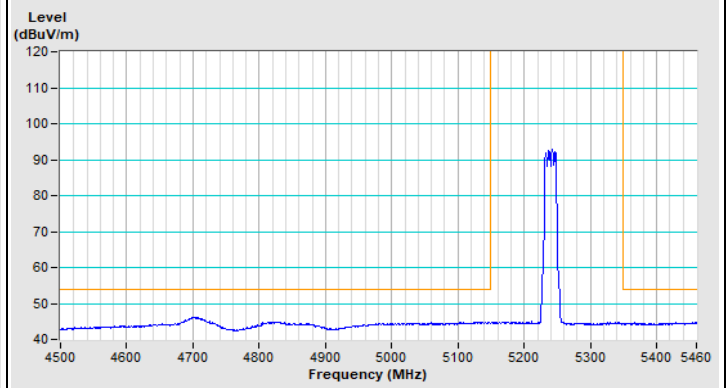

Horizontal (Average)

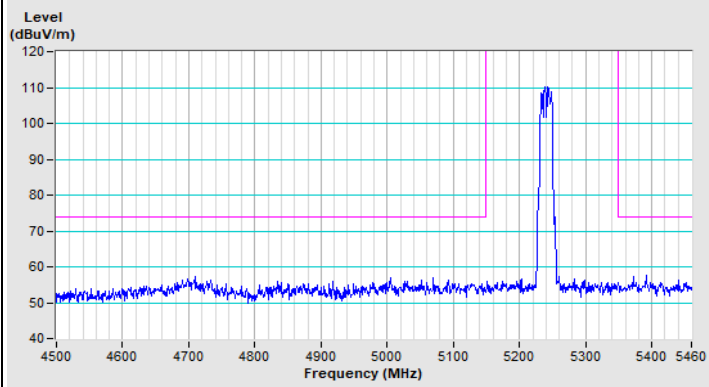

Vertical (Peak)

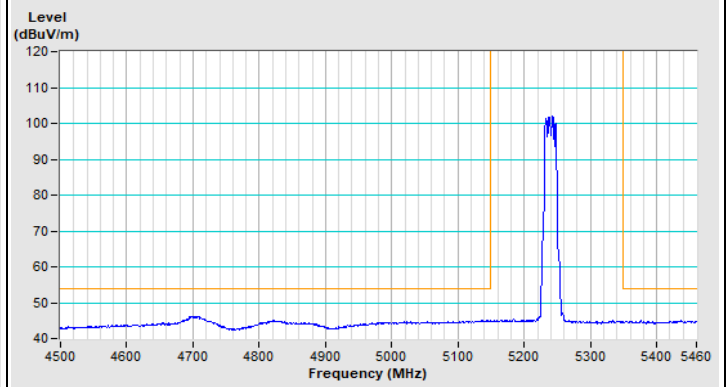

Vertical (Average)

Frequency Range	4.5 GHz ~ 5.46 GHz	Detector Function & Bandwidth	PK: RB=1 MHz, VB=3 MHz, DET=Peak AV: RB=1 MHz, VB=1 kHz, DET=Peak
-----------------	--------------------	-------------------------------	--

802.11ax (HE20) Channel 36

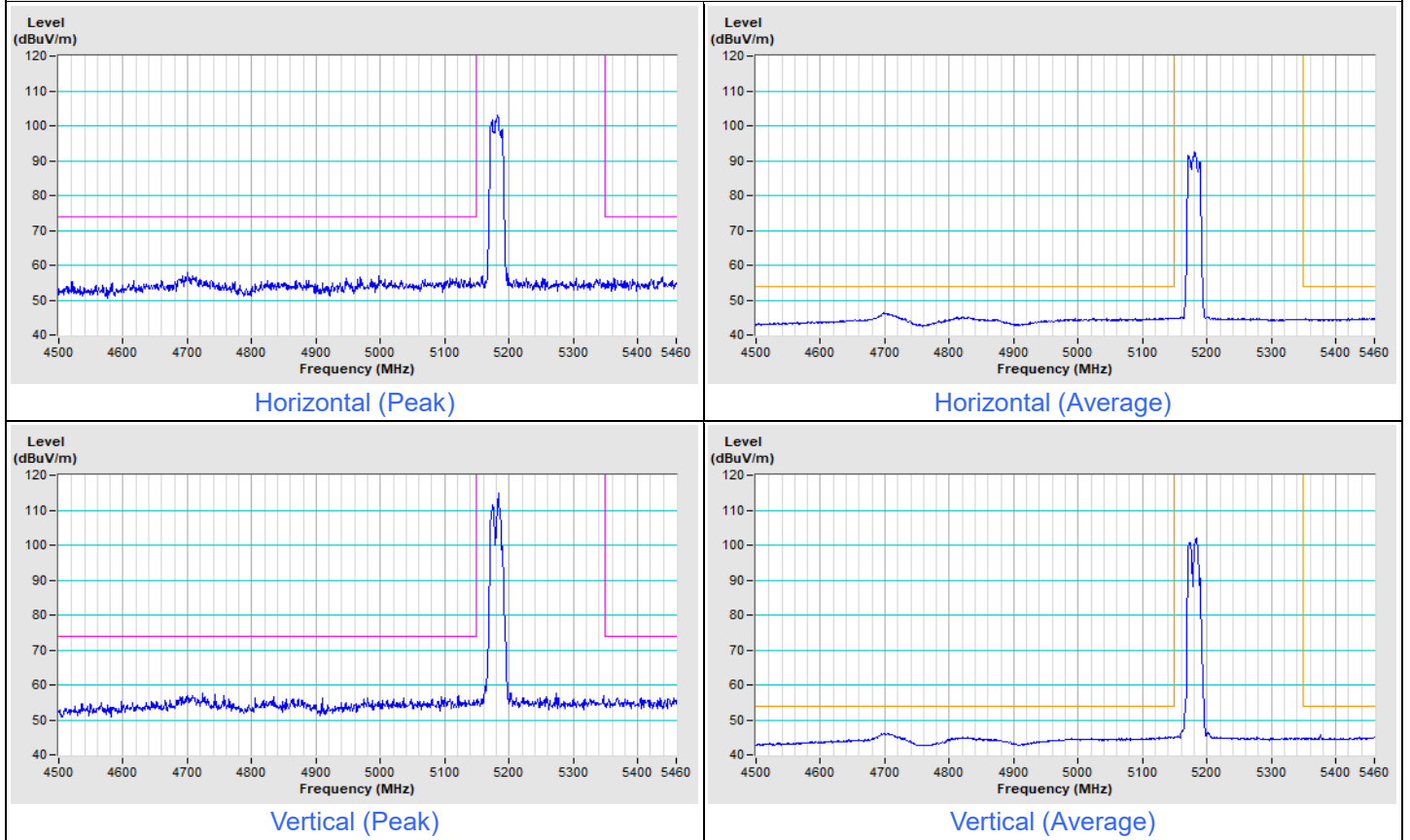

802.11ax (HE20) Channel 48

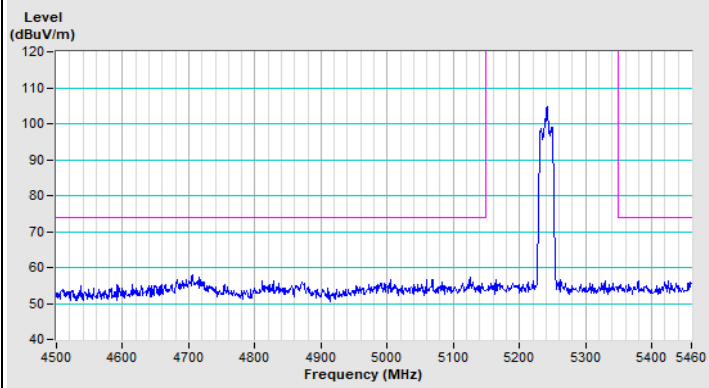

Horizontal (Peak)

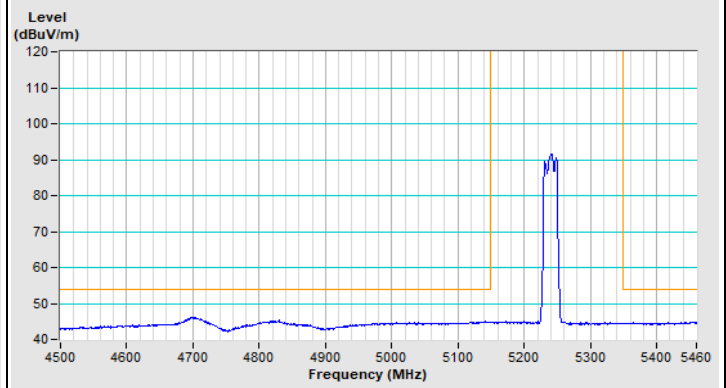

Horizontal (Average)

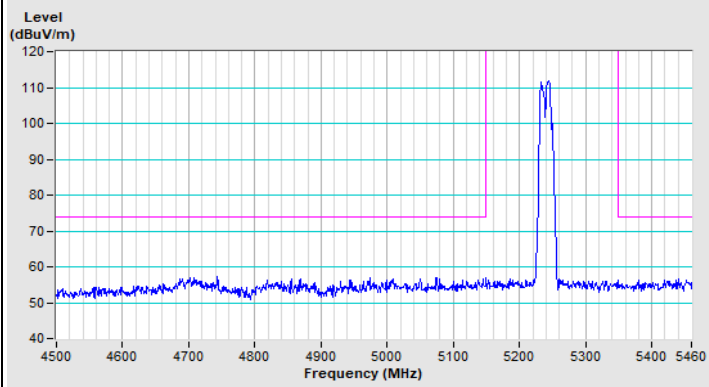

Vertical (Peak)

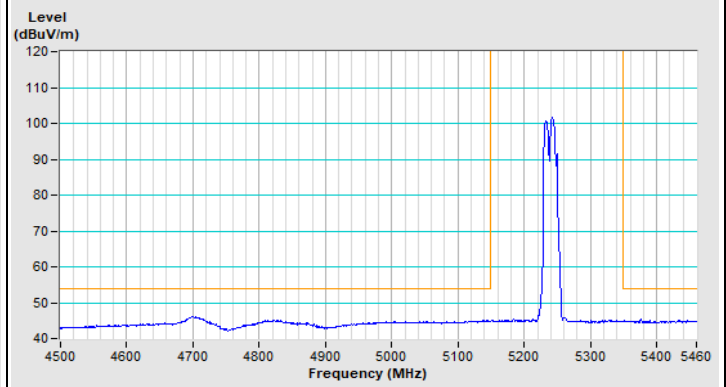

Vertical (Average)

Frequency Range	4.5 GHz ~ 5.46 GHz	Detector Function & Bandwidth	PK: RB=1 MHz, VB=3 MHz, DET=Peak AV: RB=1 MHz, VB=1 kHz, DET=Peak
-----------------	--------------------	-------------------------------	--

802.11ax (HE40) Channel 38

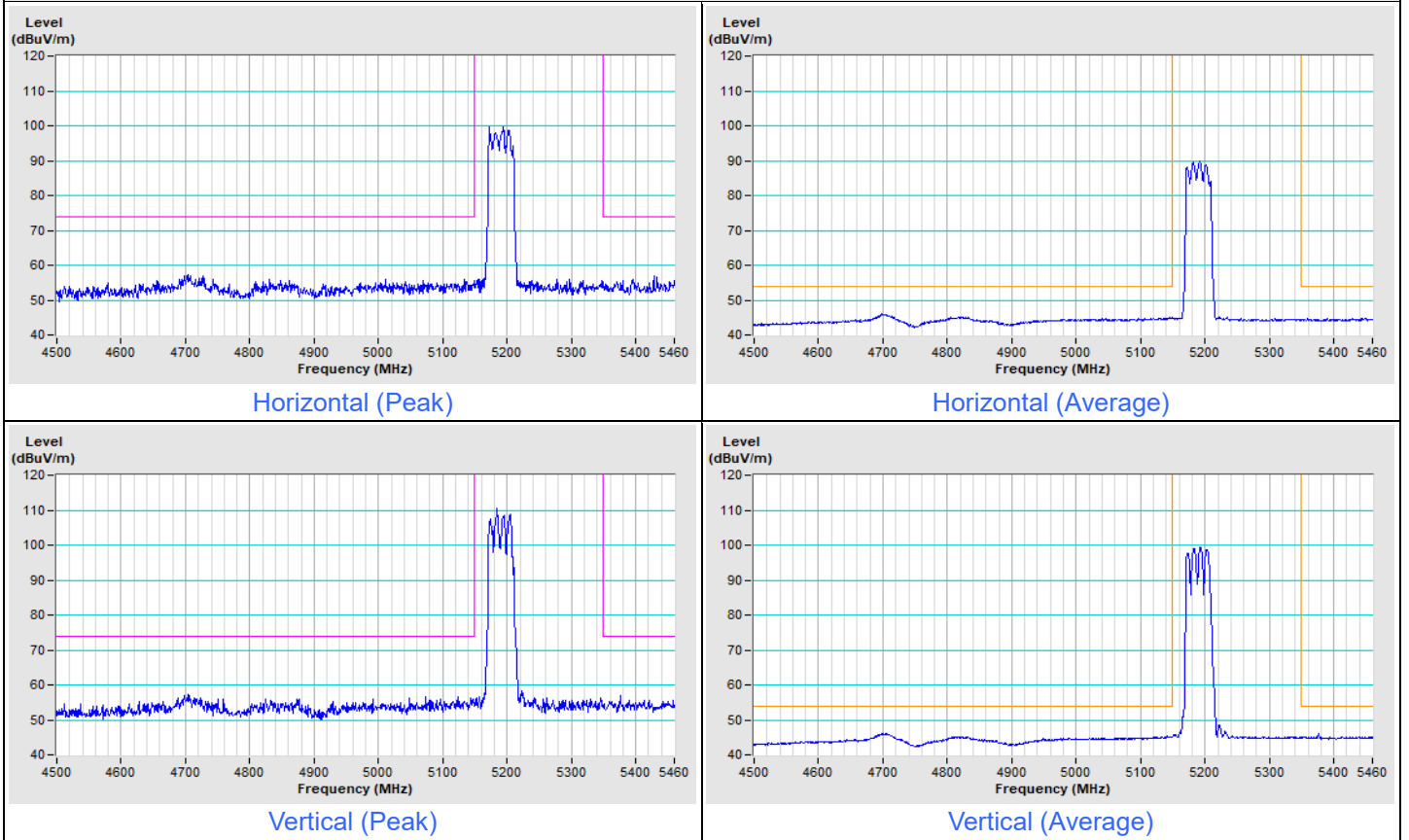

802.11ax (HE40) Channel 46

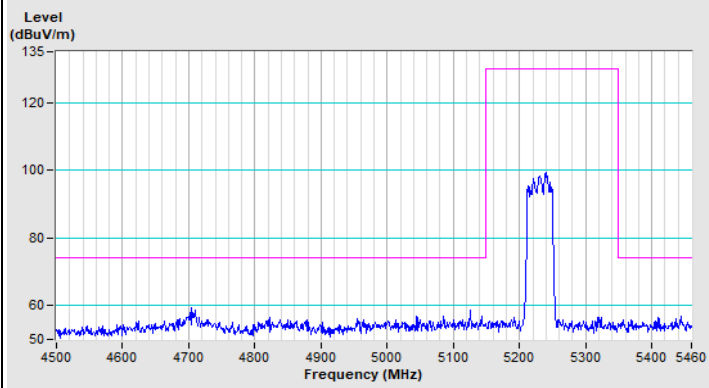

Horizontal (Peak)

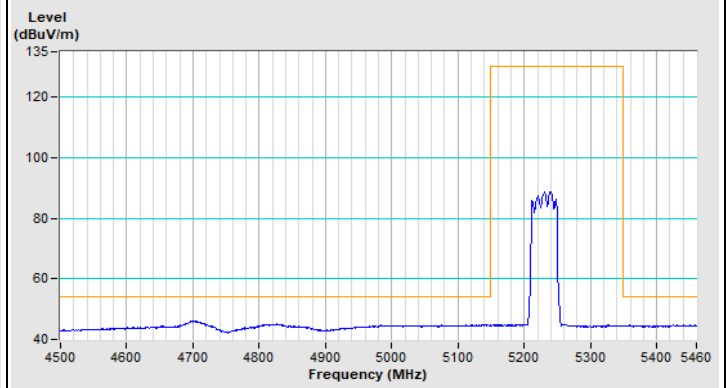

Horizontal (Average)

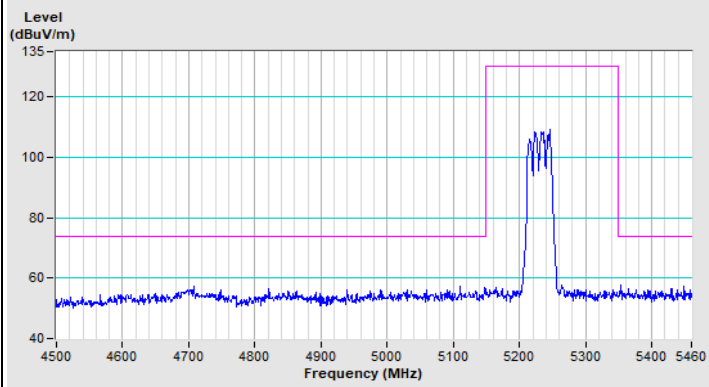

Vertical (Peak)

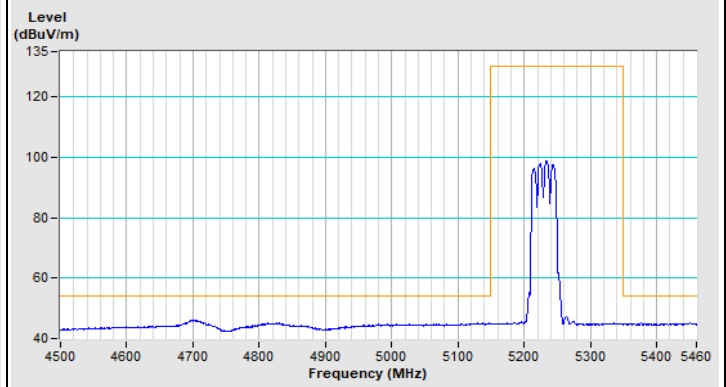

Vertical (Average)



Frequency Range	4.5 GHz ~ 5.46 GHz	Detector Function & Bandwidth	PK: RB=1 MHz, VB=3 MHz, DET=Peak AV: RB=1 MHz, VB=1 kHz, DET=Peak
-----------------	--------------------	-------------------------------	--

802.11ax (HE80) Channel 42

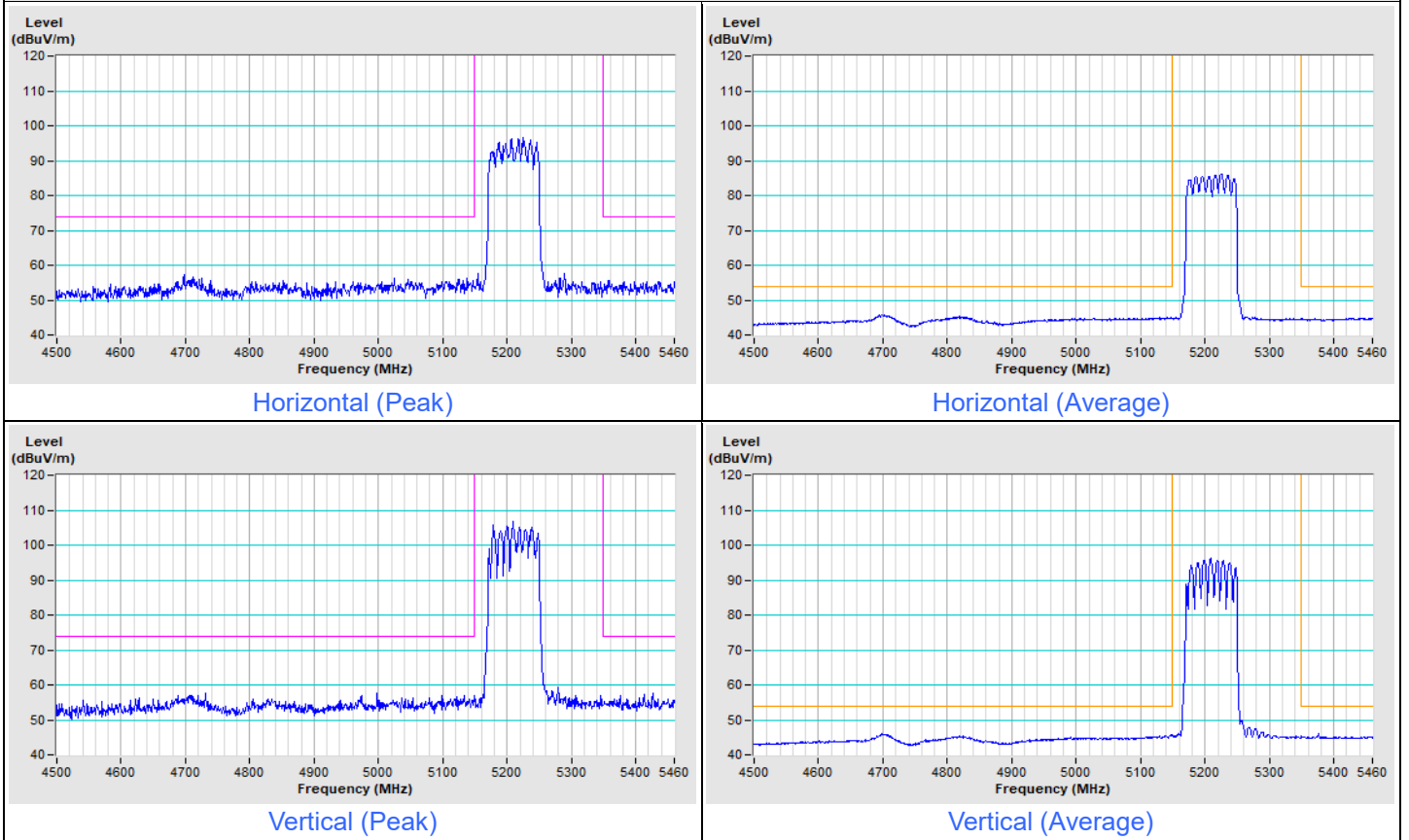

Frequency Range	4.5 GHz ~ 5.46 GHz	Detector Function & Bandwidth	PK: RB=1 MHz, VB=3 MHz, DET=Peak AV: RB=1 MHz, VB=1 kHz, DET=Peak
-----------------	--------------------	-------------------------------	--

802.11a Channel 52

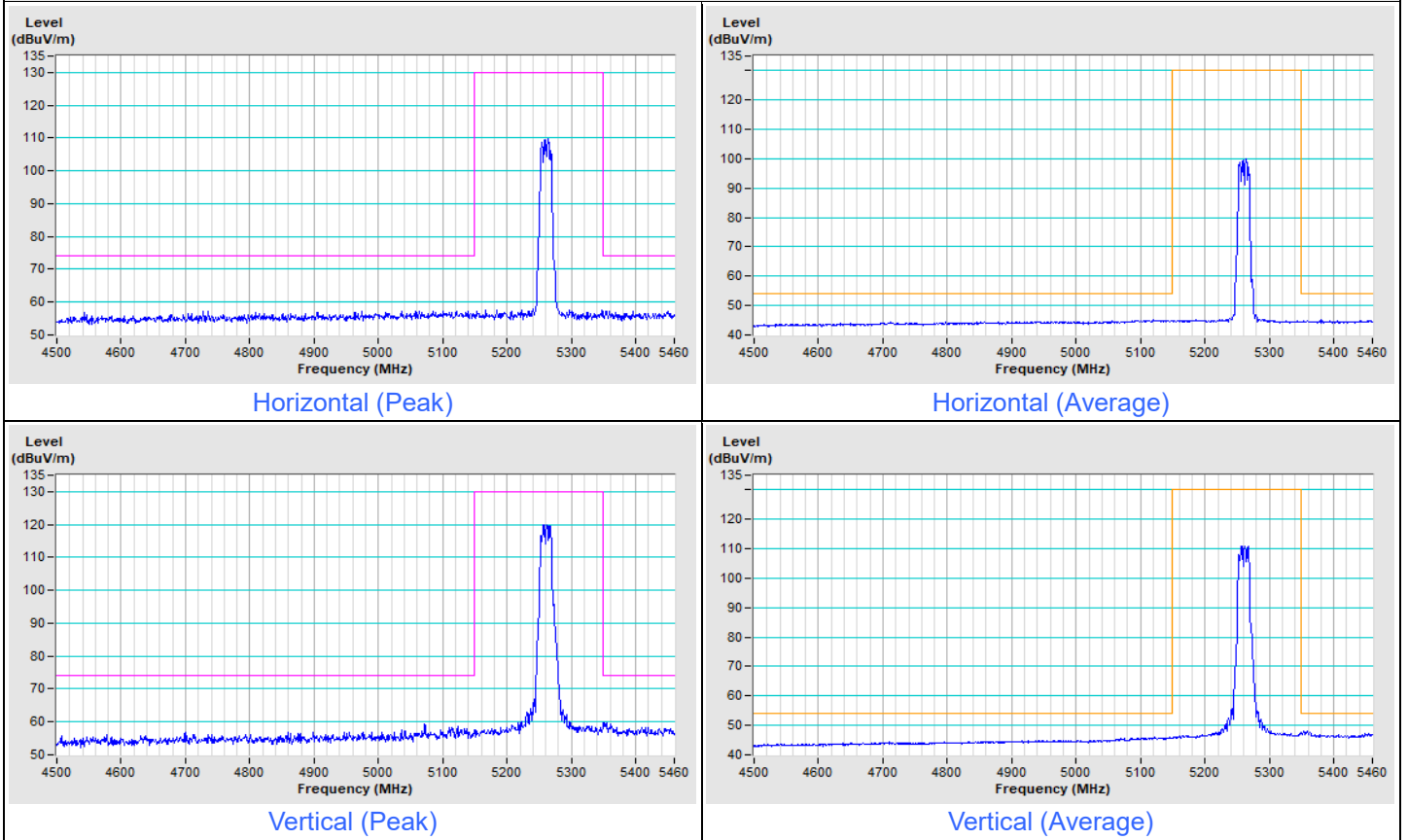

802.11a Channel 64

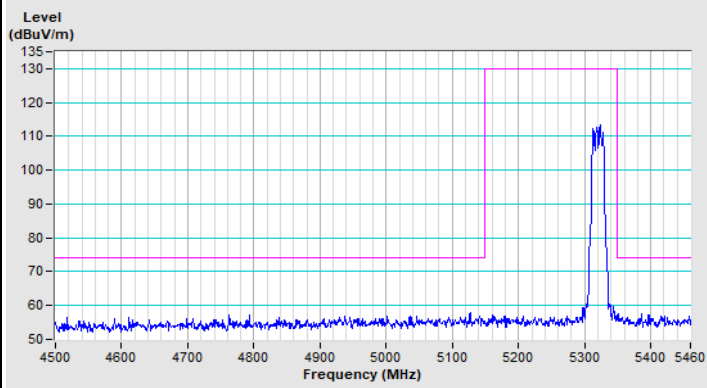

Horizontal (Peak)

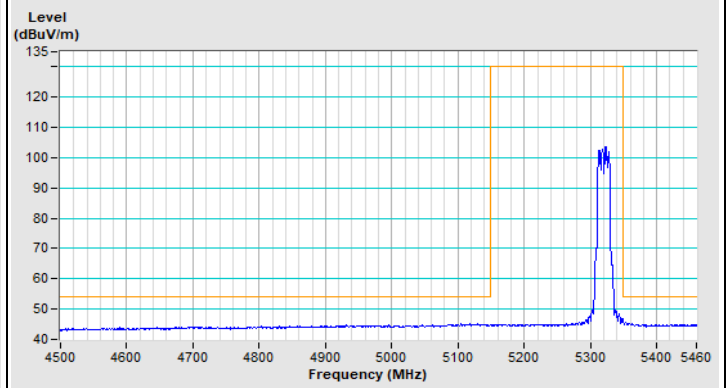

Horizontal (Average)

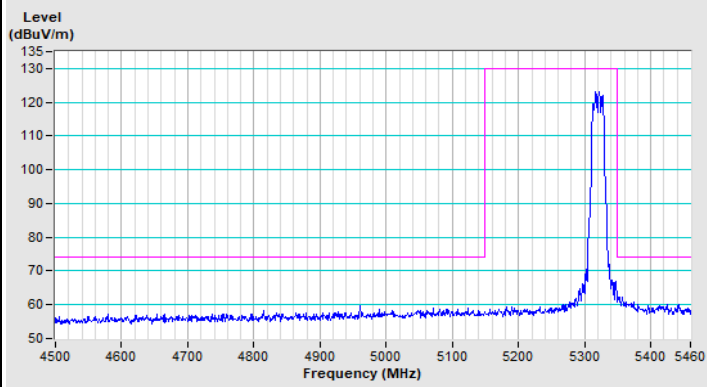

Vertical (Peak)

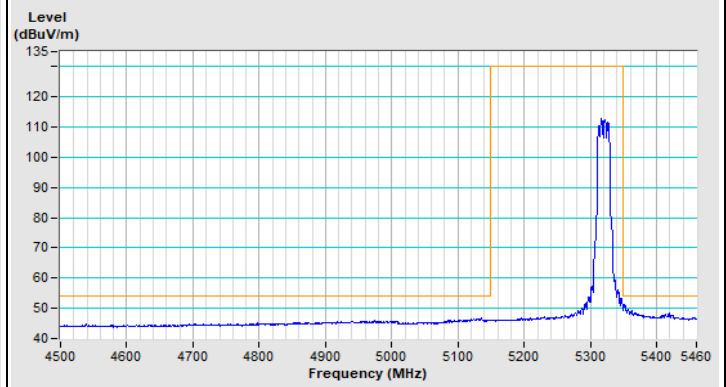

Vertical (Average)

Frequency Range	4.5 GHz ~ 5.46 GHz	Detector Function & Bandwidth	PK: RB=1 MHz, VB=3 MHz, DET=Peak AV: RB=1 MHz, VB=1 kHz, DET=Peak
-----------------	--------------------	-------------------------------	--

802.11ax (HE20) Channel 52

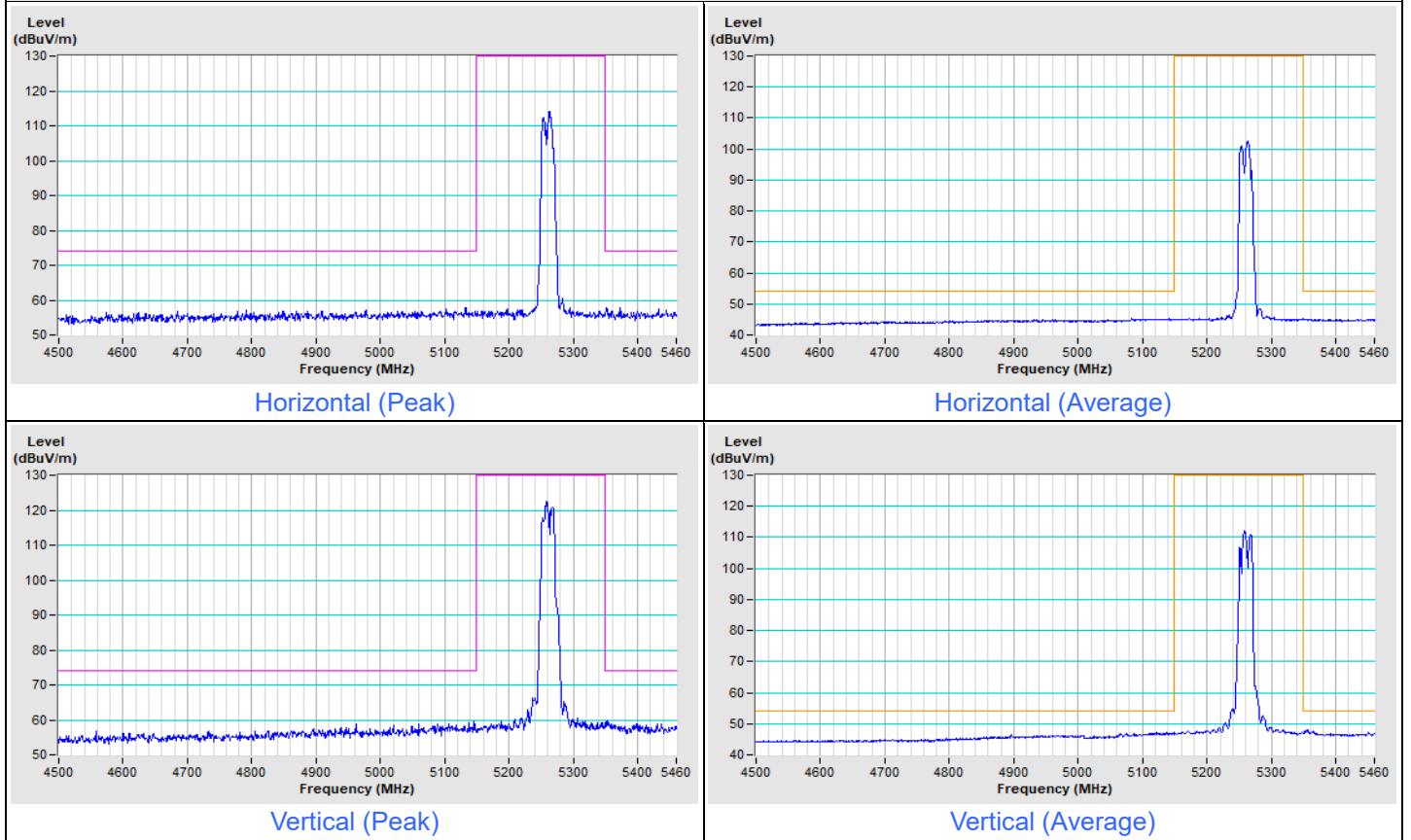

802.11ax (HE20) Channel 64

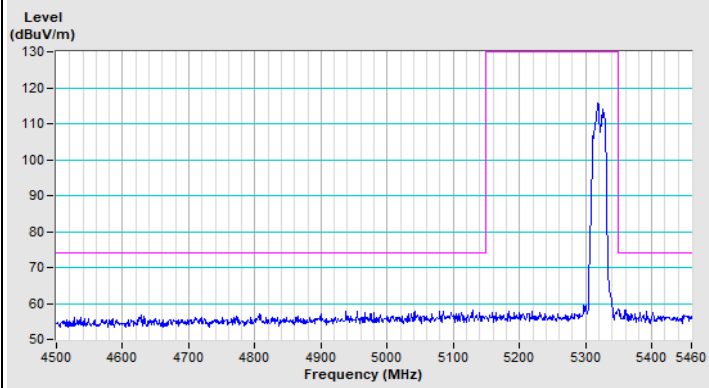

Horizontal (Peak)

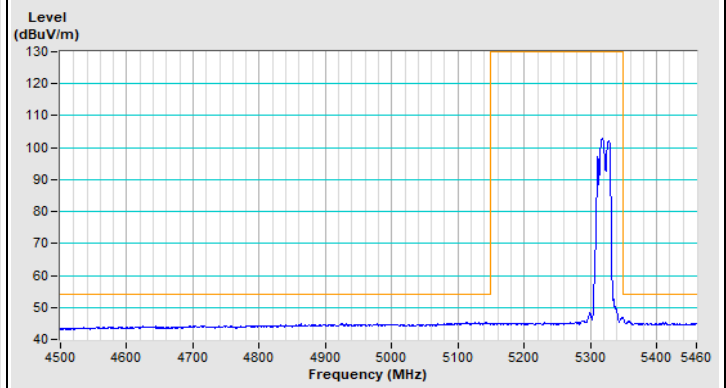

Horizontal (Average)

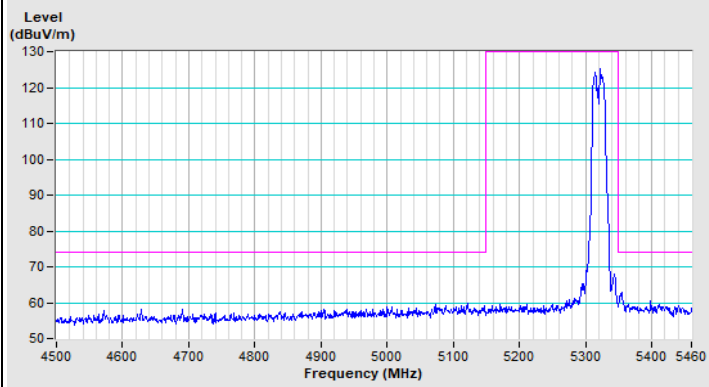

Vertical (Peak)

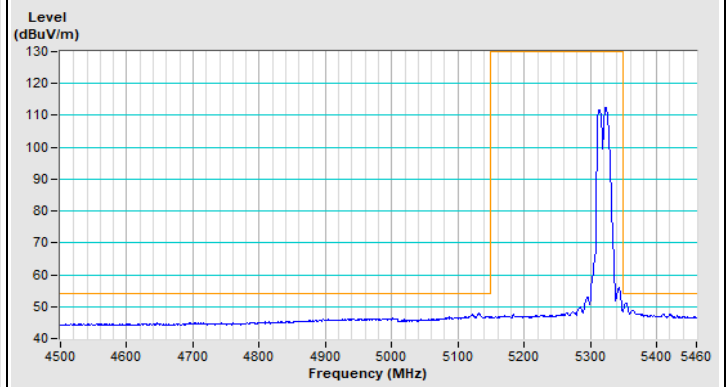

Vertical (Average)



Frequency Range	4.5 GHz ~ 5.46 GHz	Detector Function & Bandwidth	PK: RB=1 MHz, VB=3 MHz, DET=Peak AV: RB=1 MHz, VB=1 kHz, DET=Peak
-----------------	--------------------	-------------------------------	--

802.11ax (HE40) Channel 54

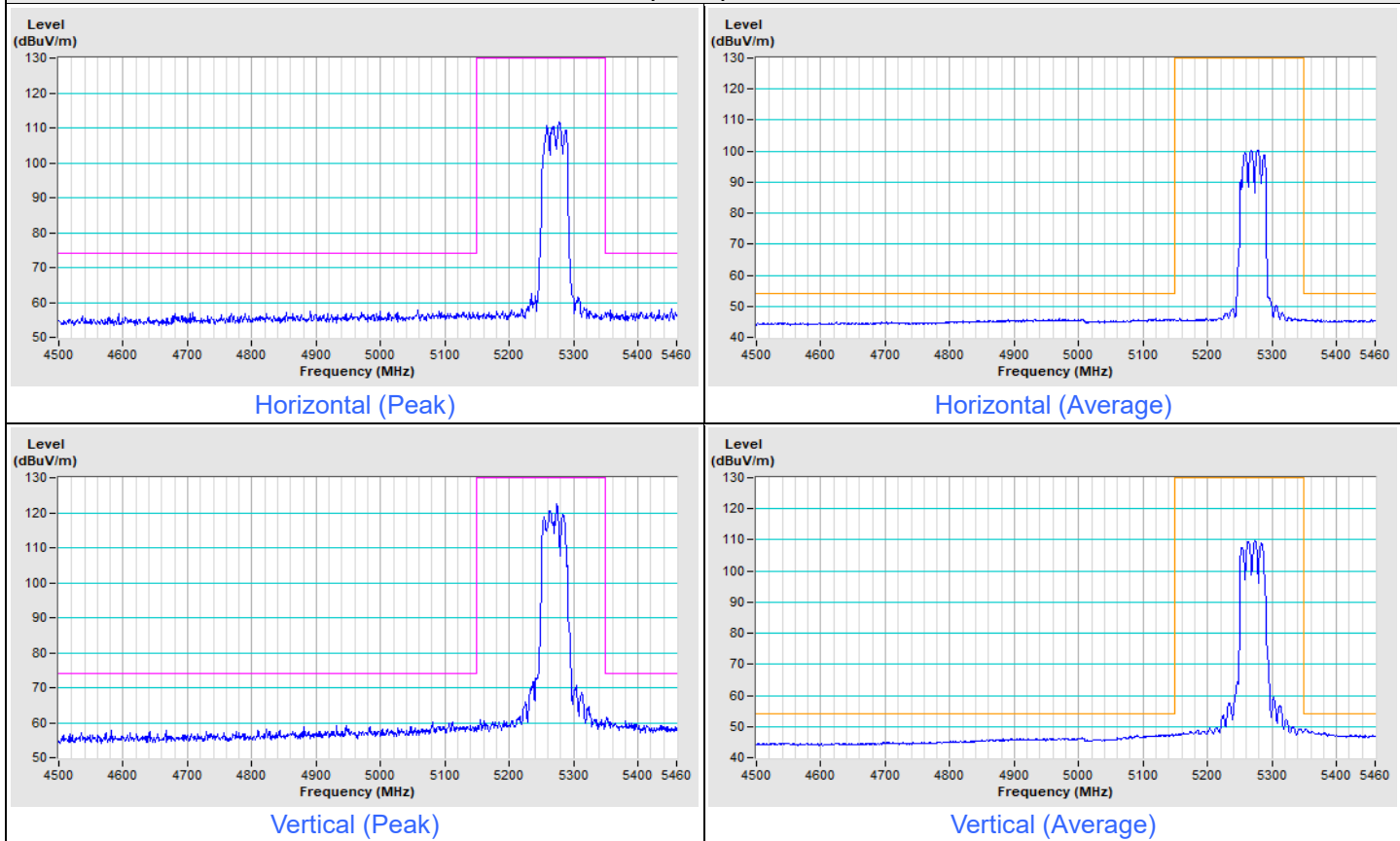

802.11ax (HE40) Channel 62

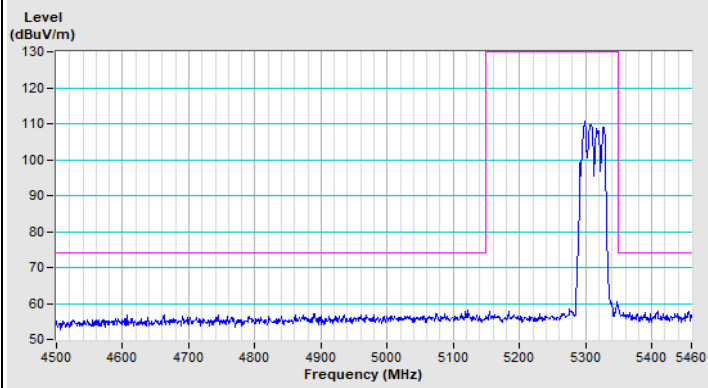

Horizontal (Peak)

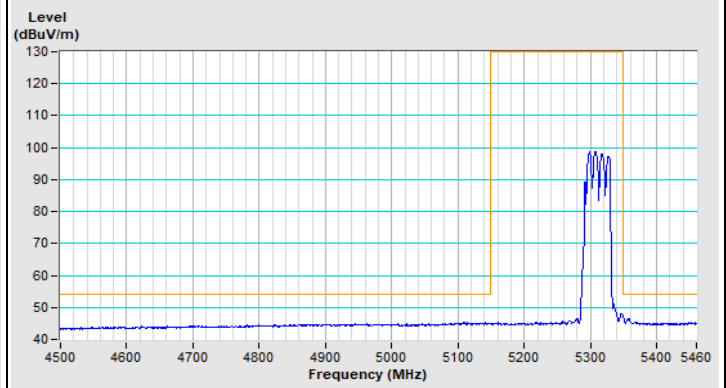

Horizontal (Average)

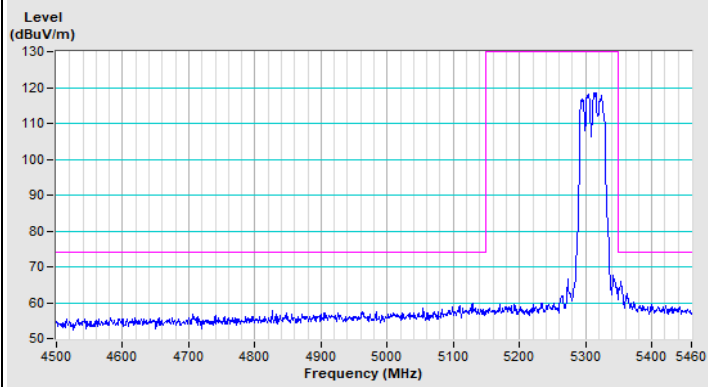

Vertical (Peak)

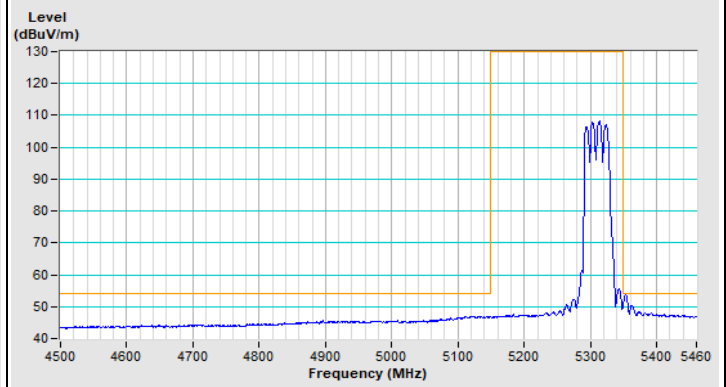

Vertical (Average)

Frequency Range	4.5 GHz ~ 5.46 GHz	Detector Function & Bandwidth	PK: RB=1 MHz, VB=3 MHz, DET=Peak AV: RB=1 MHz, VB=1 kHz, DET=Peak
-----------------	--------------------	-------------------------------	--

802.11ax (HE80) Channel 58

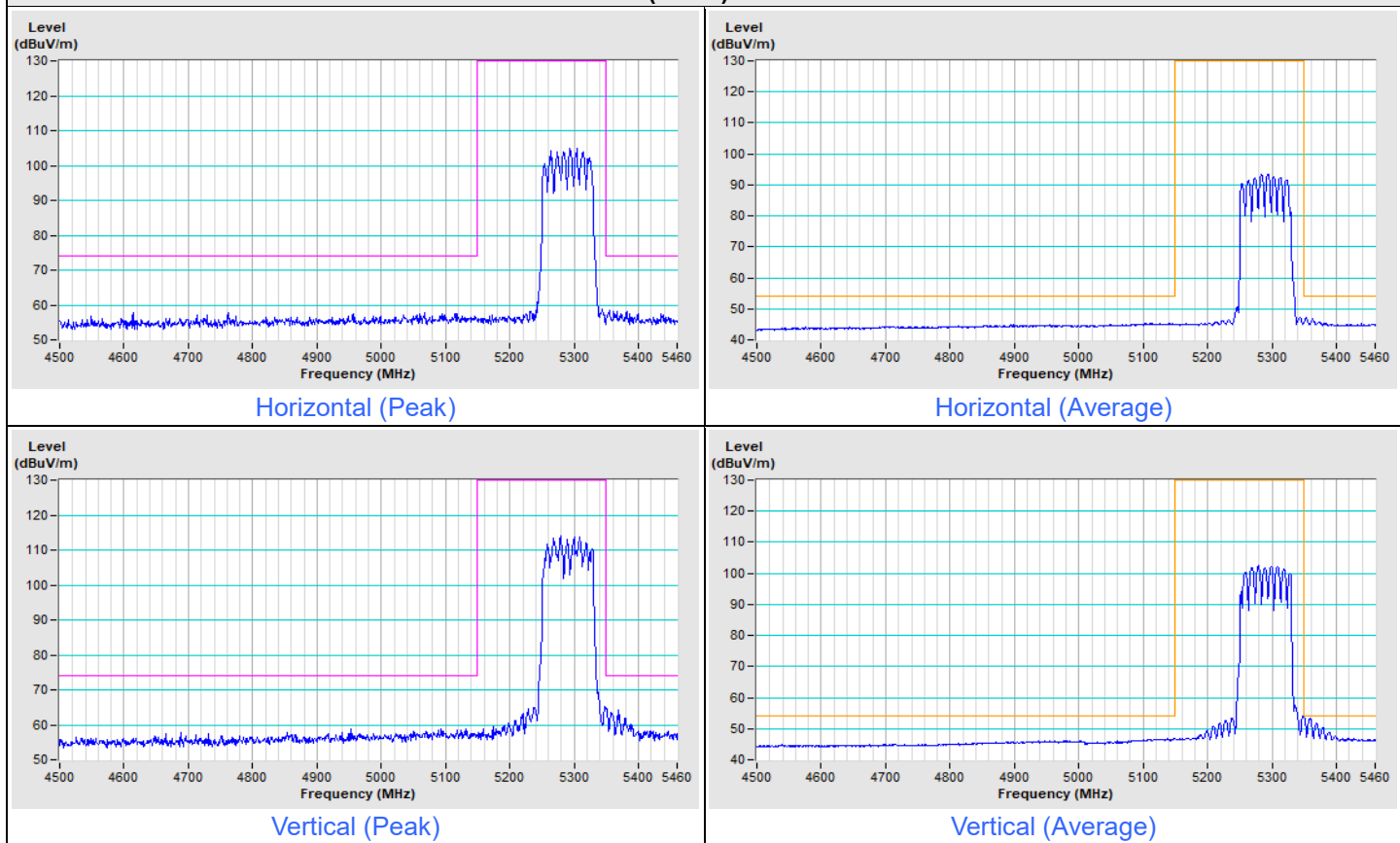



Frequency Range	5.35 GHz ~ 5.85 GHz	Detector Function & Bandwidth	PK: RB=1 MHz, VB=3 MHz, DET=Peak AV: RB=1 MHz, VB=1 kHz, DET=Peak
-----------------	---------------------	-------------------------------	--

802.11a Channel 100

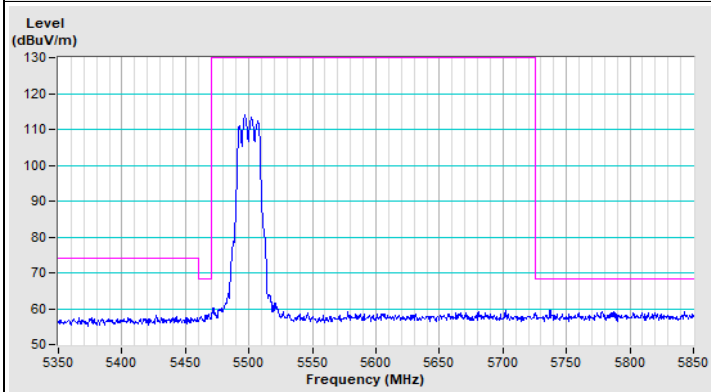

Horizontal (Peak)

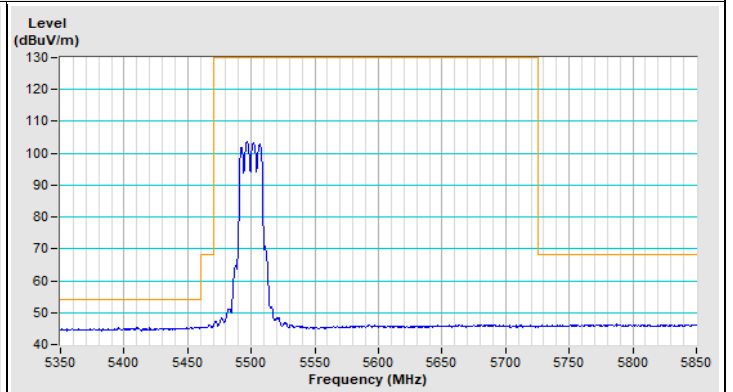

Horizontal (Average)

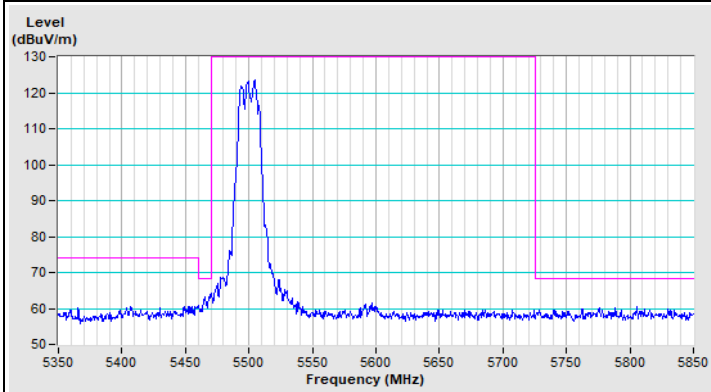

Vertical (Peak)

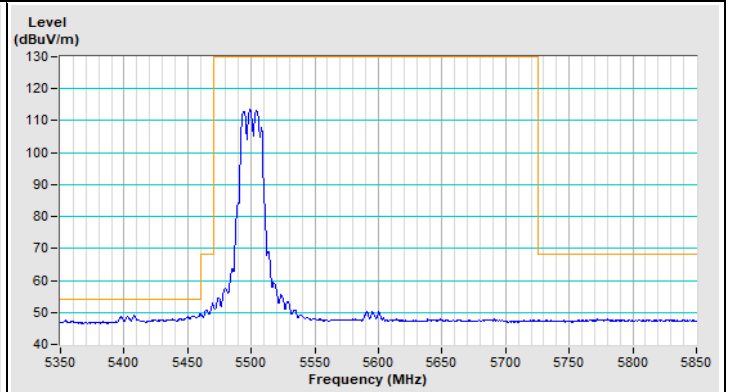

Vertical (Average)

802.11a Channel 140

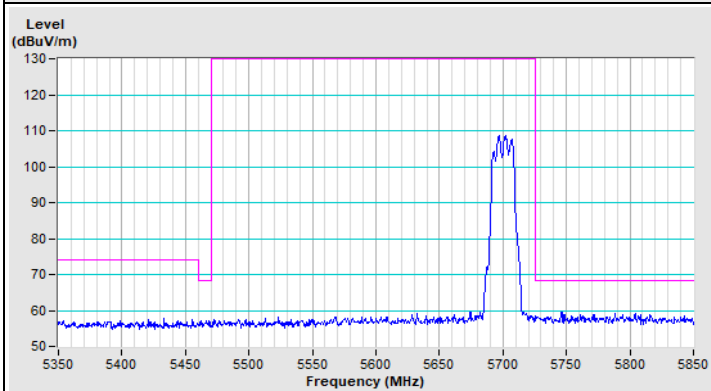

Horizontal (Peak)

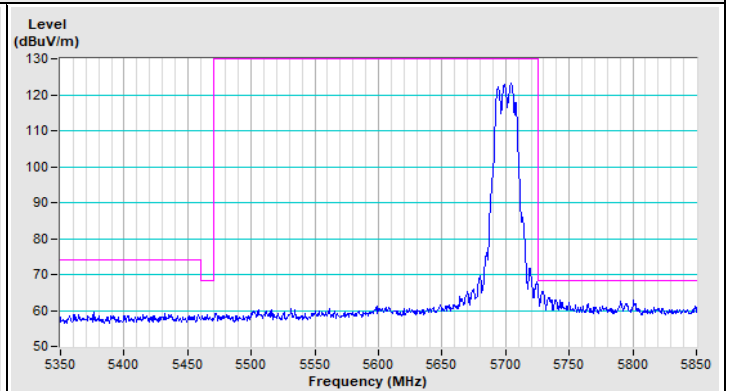

Vertical (Peak)

Frequency Range	5.35 GHz ~ 5.95 GHz	Detector Function & Bandwidth	PK: RB=1 MHz, VB=3 MHz, DET=Peak
-----------------	---------------------	-------------------------------	----------------------------------

802.11a Channel 144

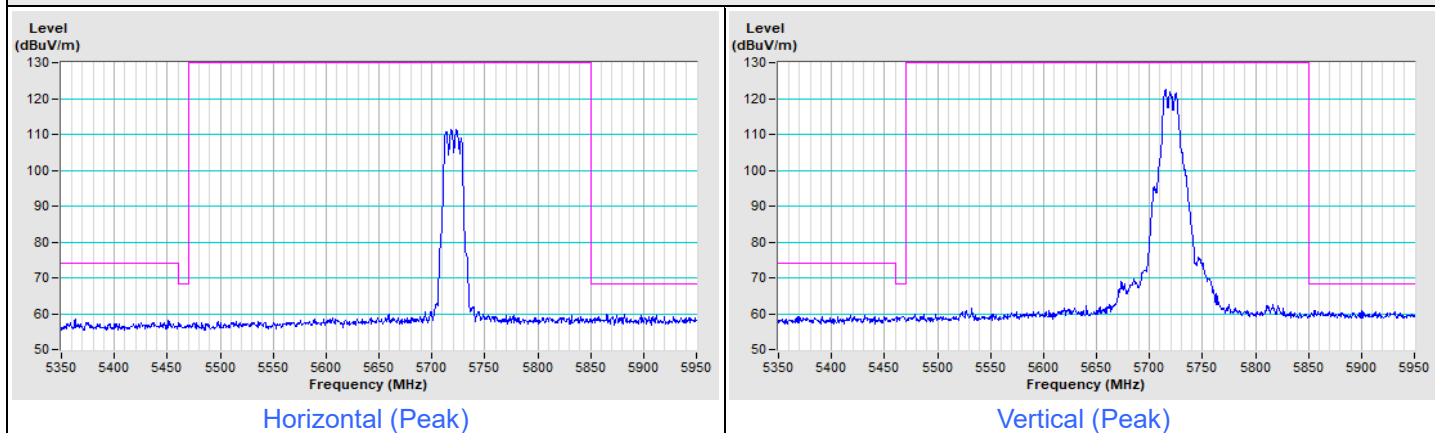

Frequency Range	5.35 GHz ~ 5.85 GHz	Detector Function & Bandwidth	PK: RB=1 MHz, VB=3 MHz, DET=Peak AV: RB=1 MHz, VB=1 kHz, DET=Peak
-----------------	---------------------	-------------------------------	--

802.11ax (HE20) Channel 100

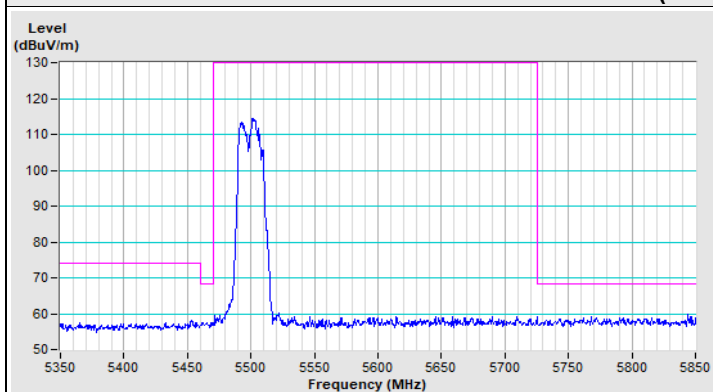

Horizontal (Peak)

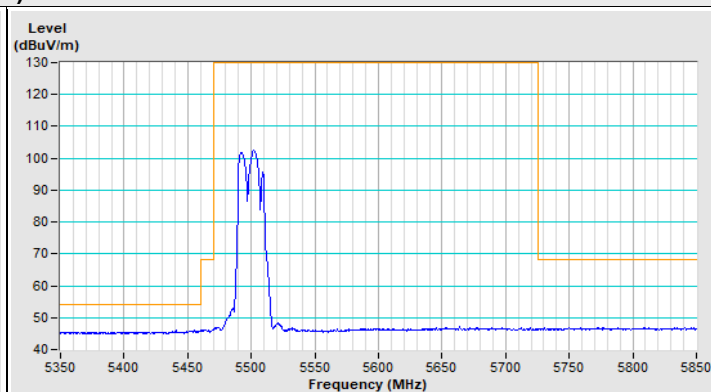

Horizontal (Average)

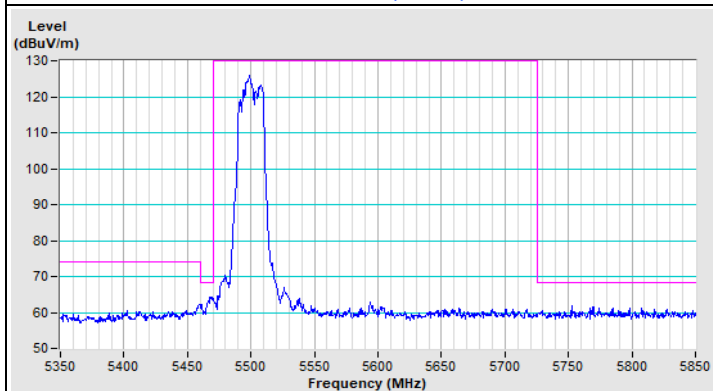

Vertical (Peak)

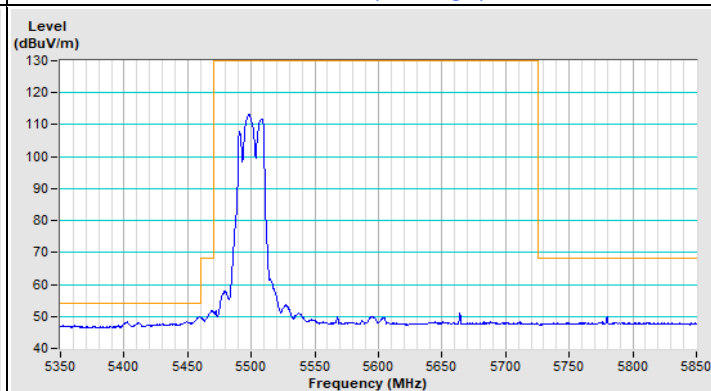

Vertical (Average)

802.11ax (HE20) Channel 140

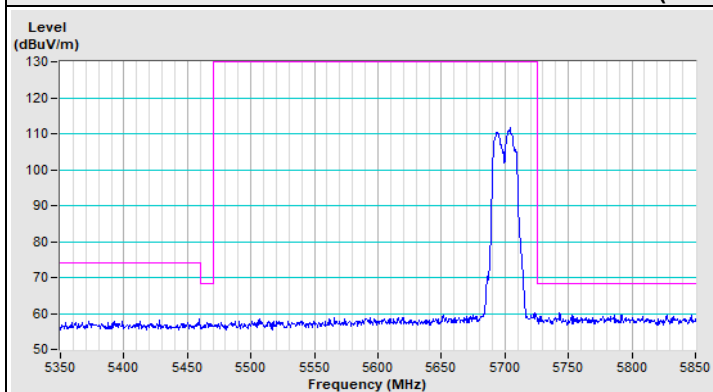

Horizontal (Peak)

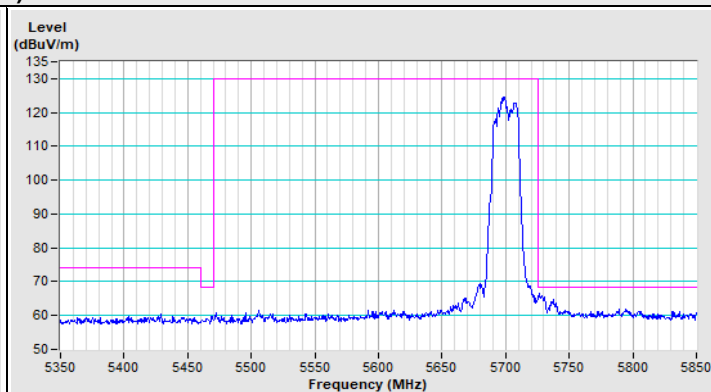

Vertical (Peak)

Frequency Range	5.35 GHz ~ 5.95 GHz	Detector Function & Bandwidth	PK: RB=1 MHz, VB=3 MHz, DET=Peak
-----------------	---------------------	-------------------------------	----------------------------------

802.11ax (HE20) Channel 144

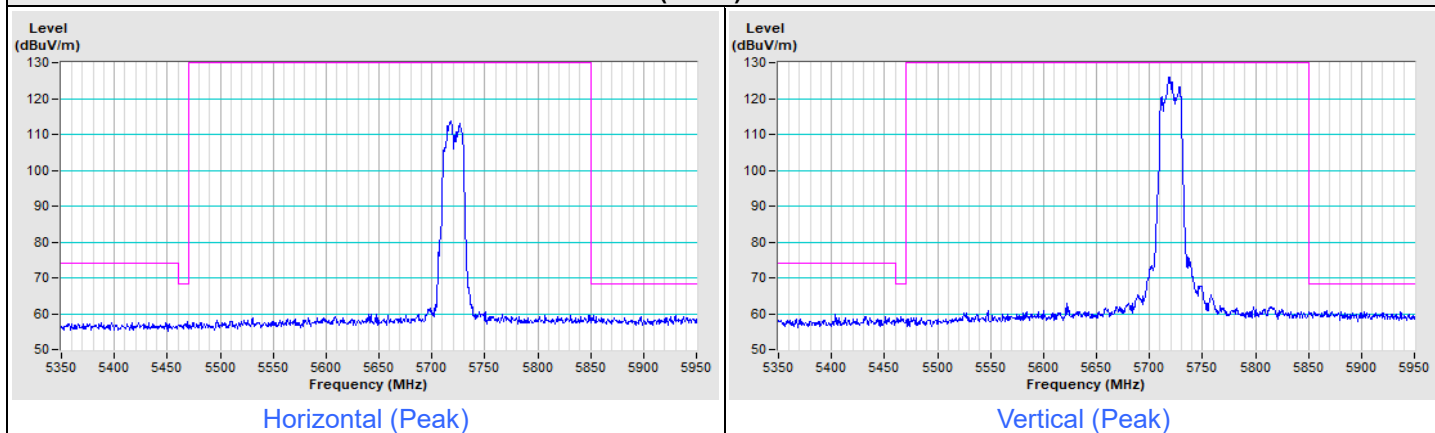

Frequency Range	5.35 GHz ~ 5.85 GHz	Detector Function & Bandwidth	PK: RB=1 MHz, VB=3 MHz, DET=Peak AV: RB=1 MHz, VB=1 kHz, DET=Peak
-----------------	---------------------	-------------------------------	--

802.11ax (HE40) Channel 102

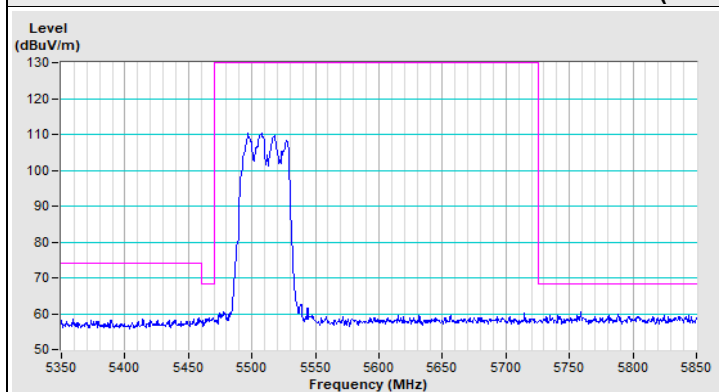

Horizontal (Peak)

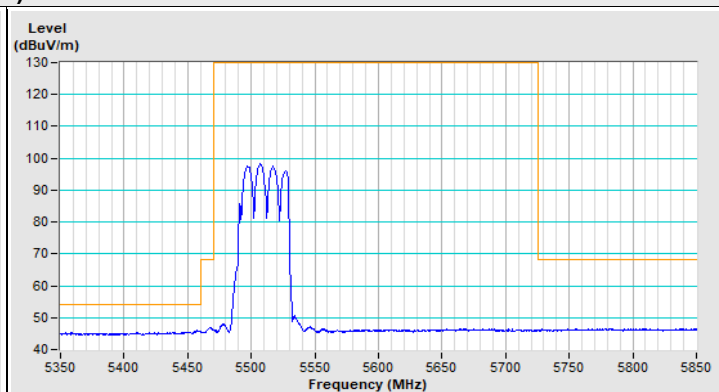

Horizontal (Average)

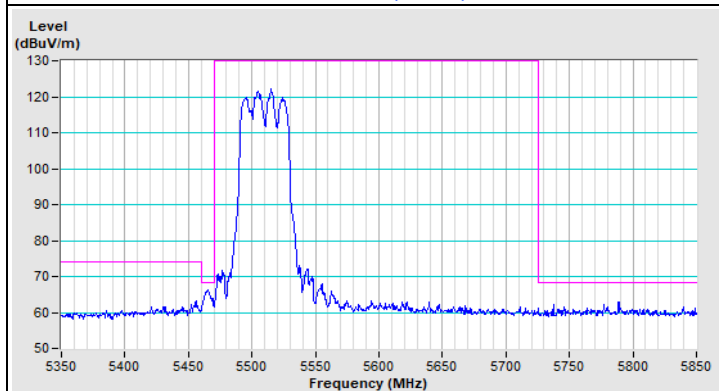

Vertical (Peak)

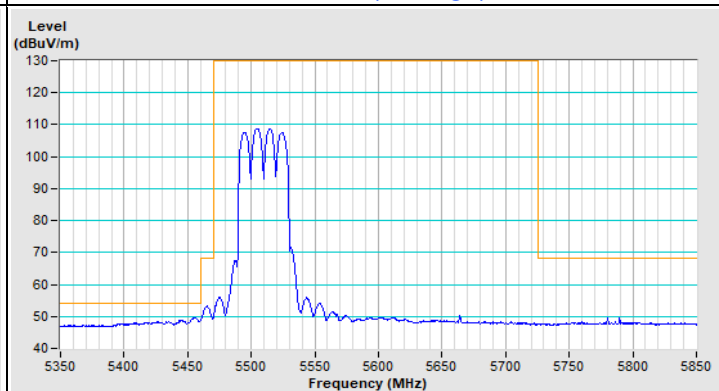

Vertical (Average)

802.11ax (HE40) Channel 134

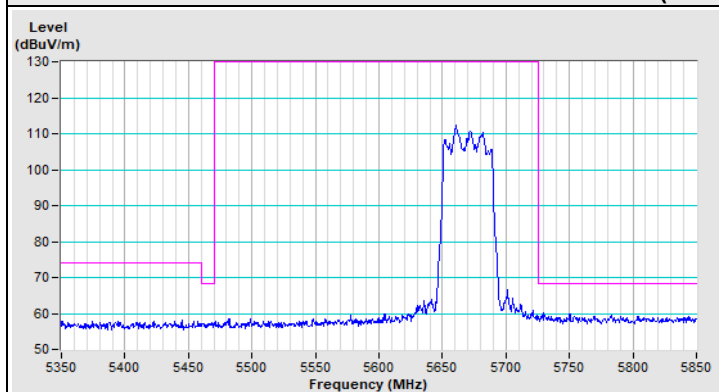

Horizontal (Peak)

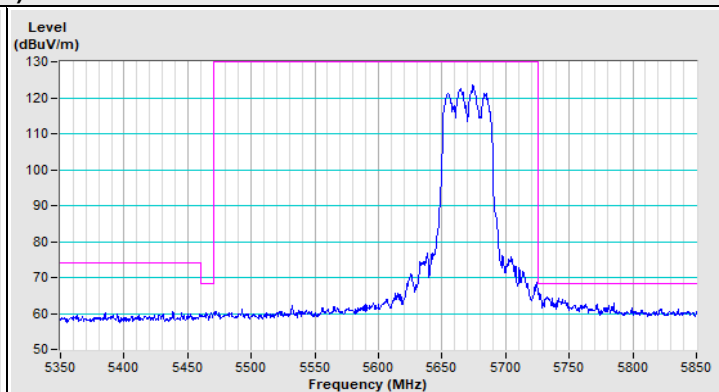

Vertical (Peak)

Frequency Range	5.35 GHz ~ 5.95 GHz	Detector Function & Bandwidth	PK: RB=1 MHz, VB=3 MHz, DET=Peak
-----------------	---------------------	-------------------------------	----------------------------------

802.11ax (HE40) Channel 142

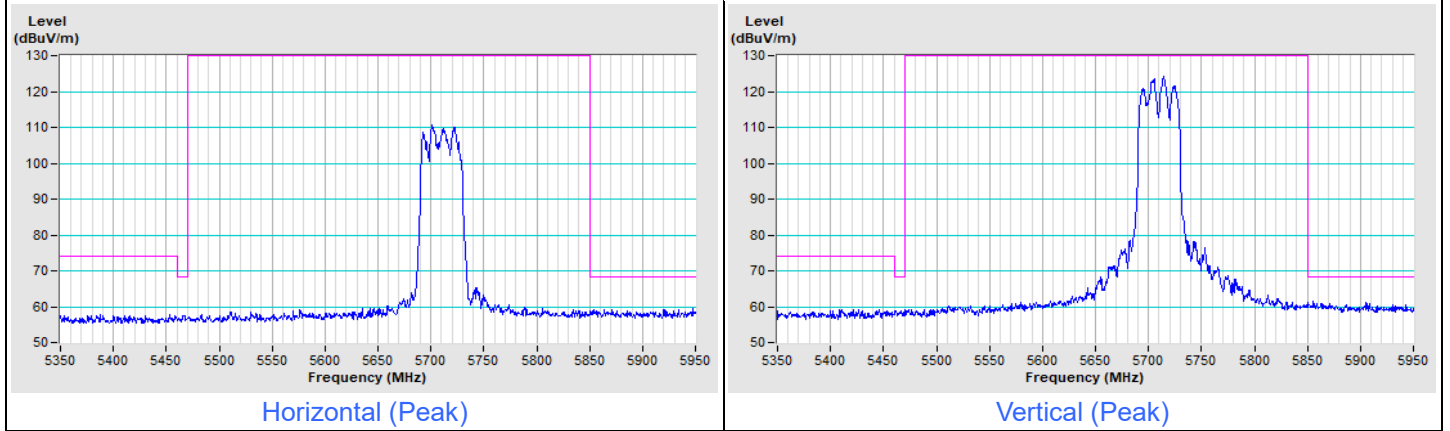

Frequency Range	5.35 GHz ~ 5.85 GHz	Detector Function & Bandwidth	PK: RB=1 MHz, VB=3 MHz, DET=Peak AV: RB=1 MHz, VB=1 kHz, DET=Peak
-----------------	---------------------	-------------------------------	--

802.11ax (HE80) Channel 106

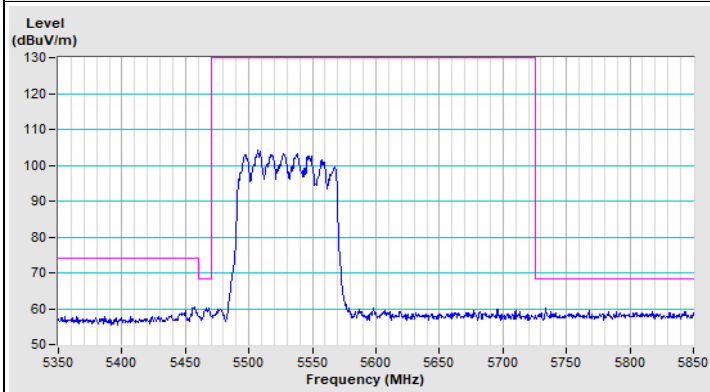

Horizontal (Peak)

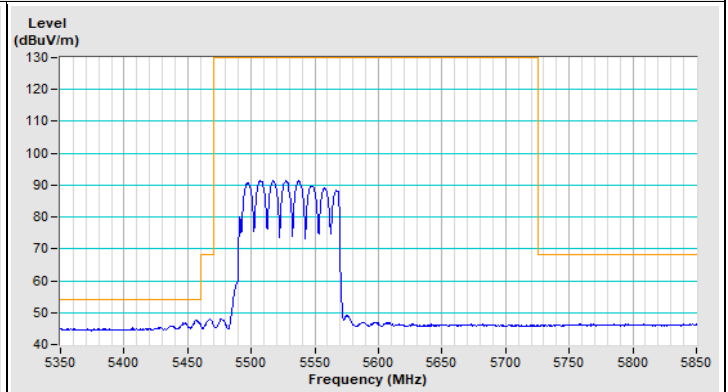

Horizontal (Average)

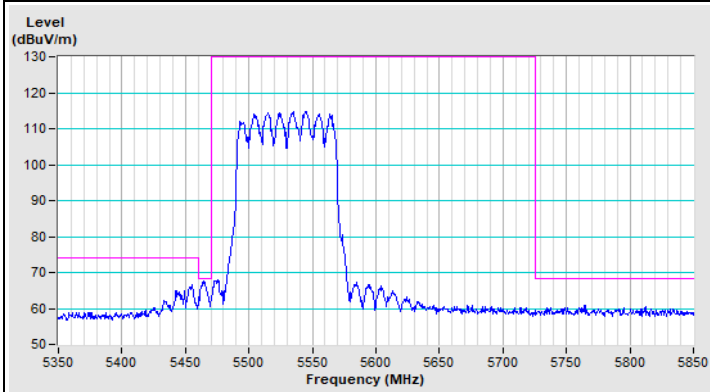

Vertical (Peak)

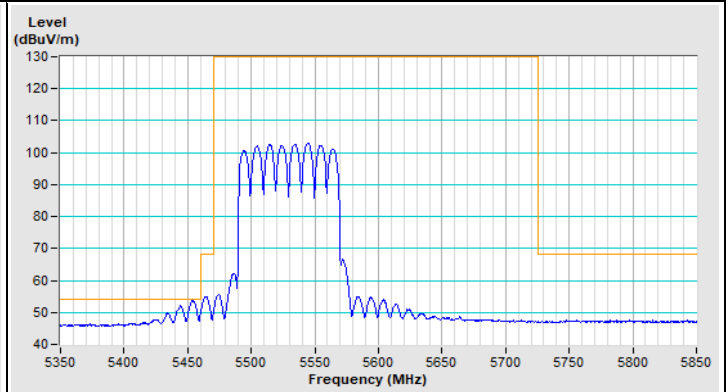

Vertical (Average)

802.11ax (HE80) Channel 122

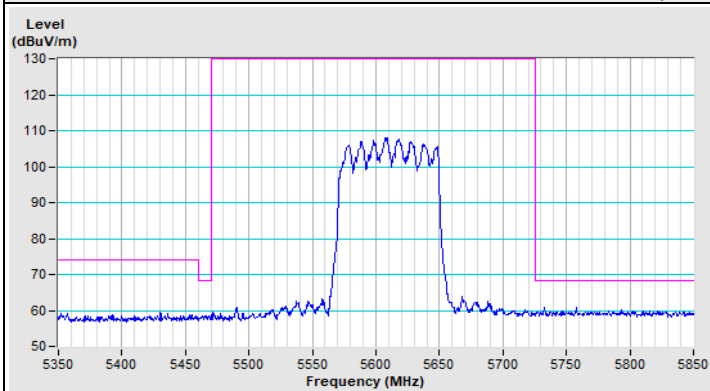

Horizontal (Peak)

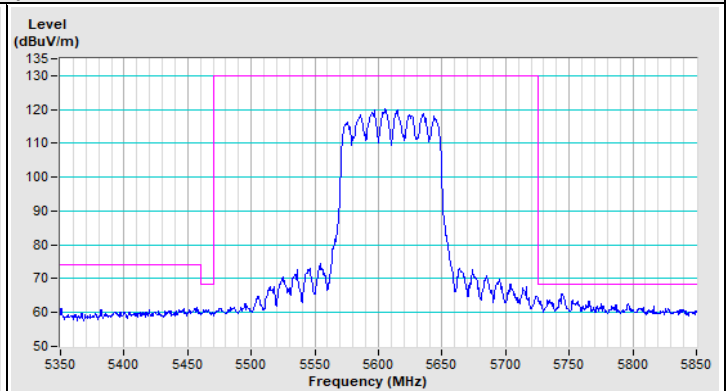

Vertical (Peak)

Frequency Range	5.35 GHz ~ 5.95 GHz	Detector Function & Bandwidth	PK: RB=1 MHz, VB=3 MHz, DET=Peak
-----------------	---------------------	-------------------------------	----------------------------------

802.11ax (HE80) Channel 138

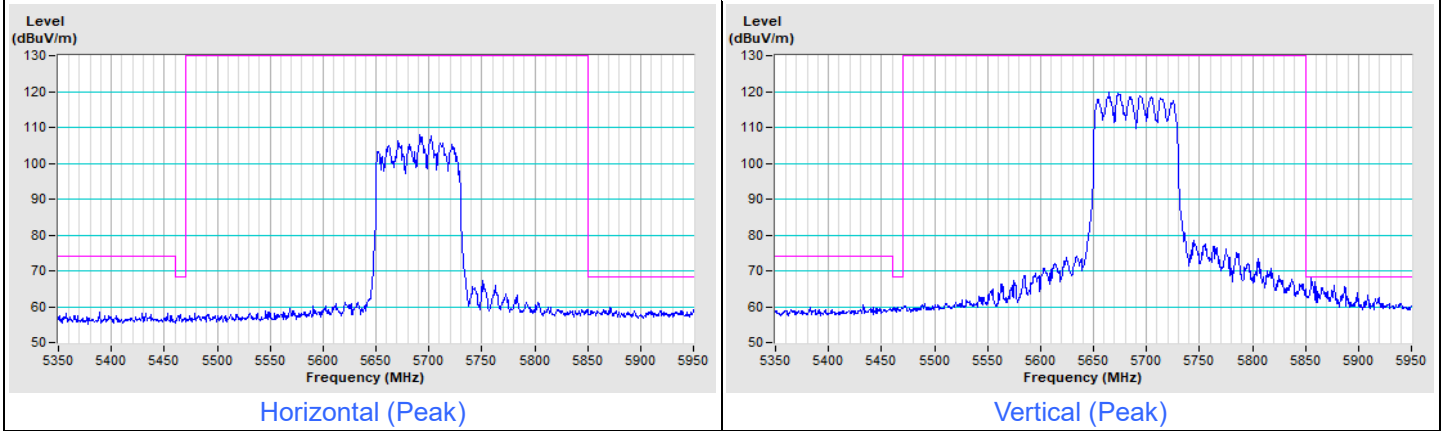

Frequency Range	5.6 GHz ~ 6 GHz	Detector Function & Bandwidth	PK: RB=1 MHz, VB=3 MHz, DET=Peak
-----------------	-----------------	-------------------------------	----------------------------------

802.11a Channel 149

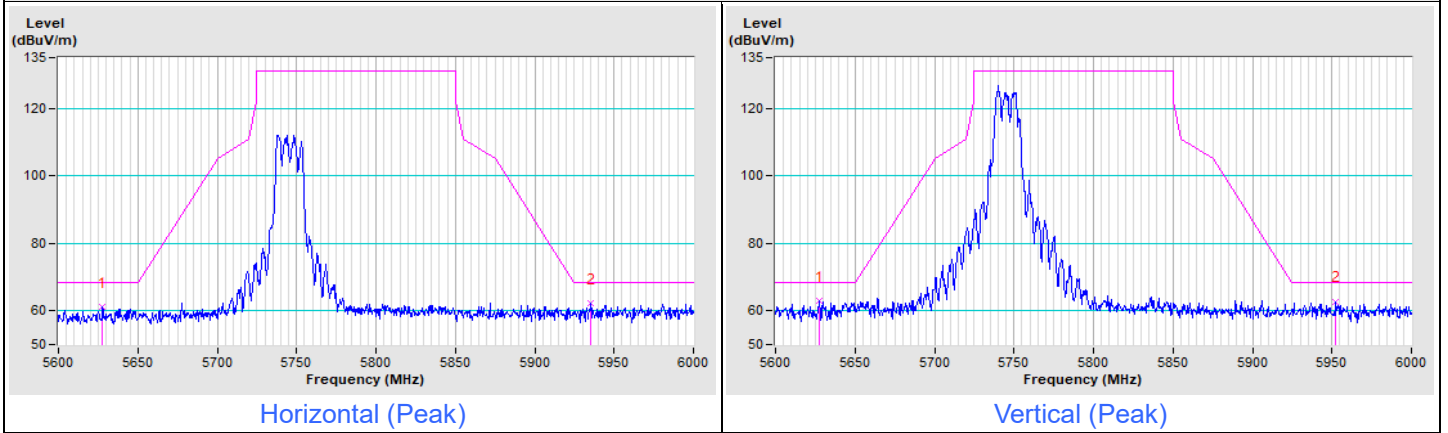

802.11a Channel 157

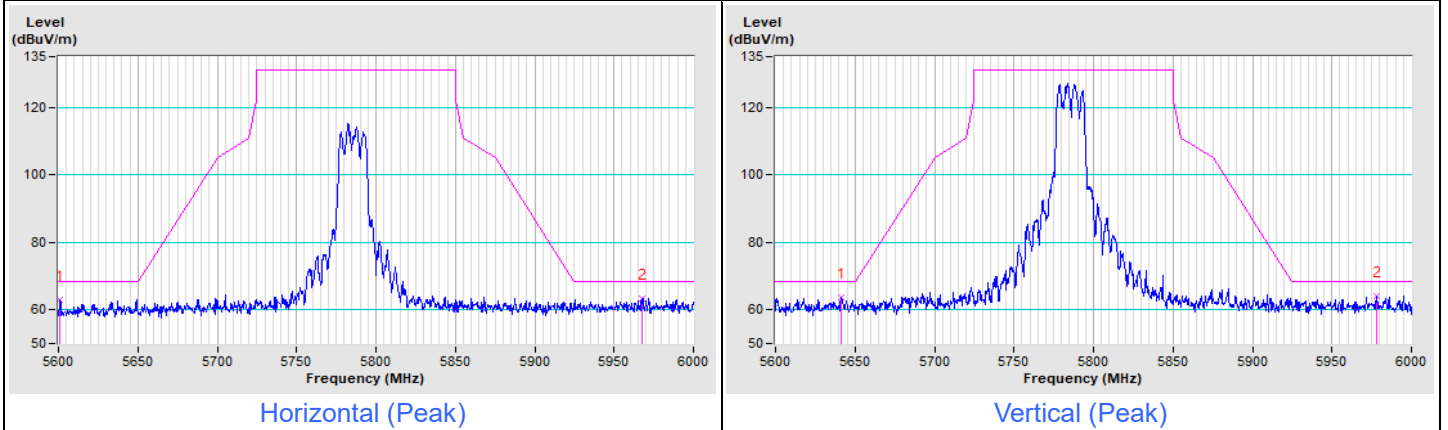

802.11a Channel 165

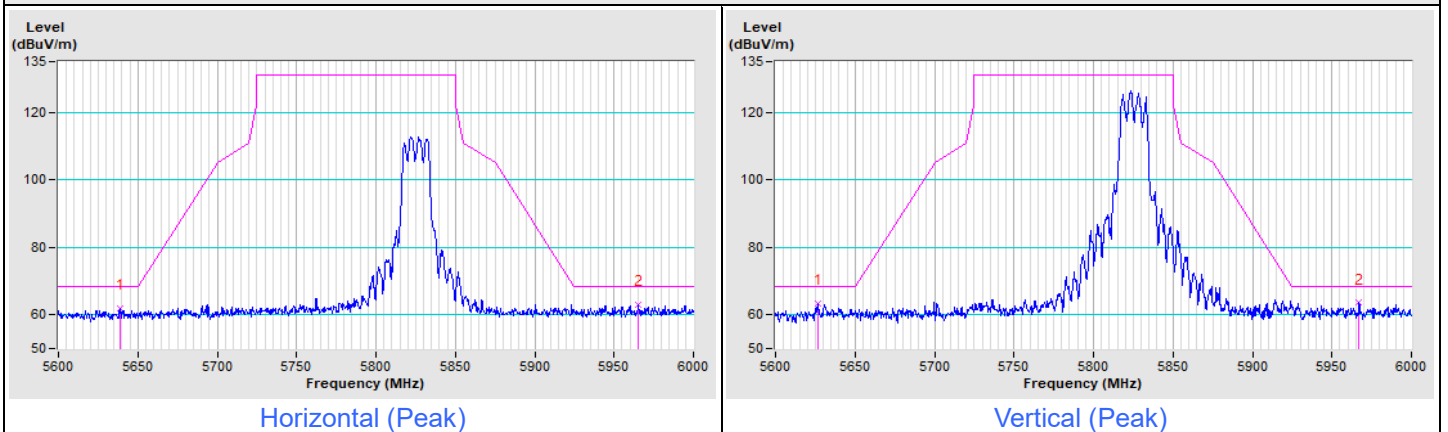

Frequency Range	5.6 GHz ~ 6 GHz	Detector Function & Bandwidth	PK: RB=1 MHz, VB=3 MHz, DET=Peak
-----------------	-----------------	-------------------------------	----------------------------------

802.11ax (HE20) Channel 149

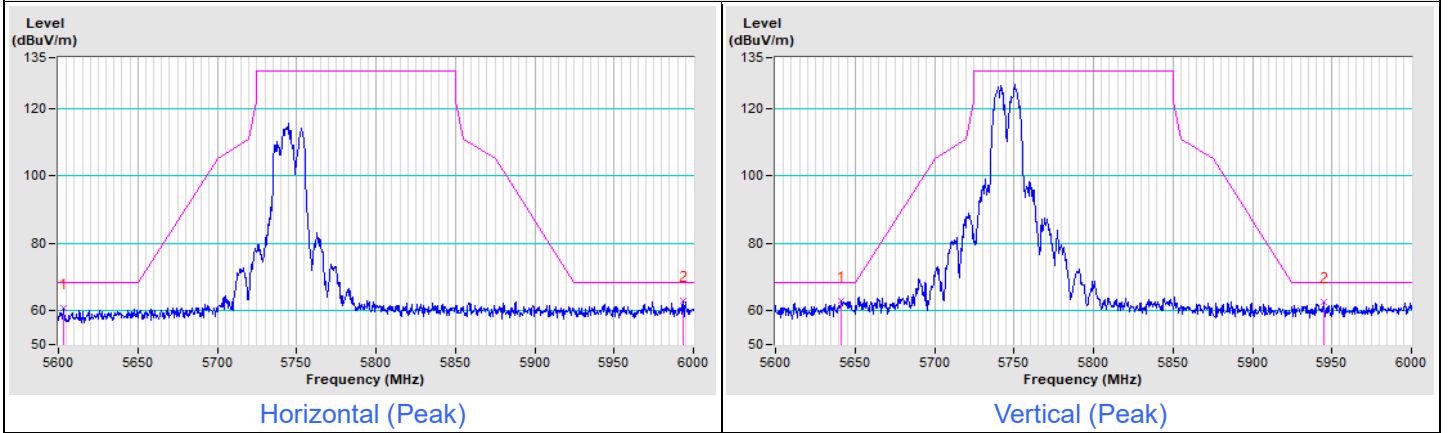

802.11ax (HE20) Channel 157

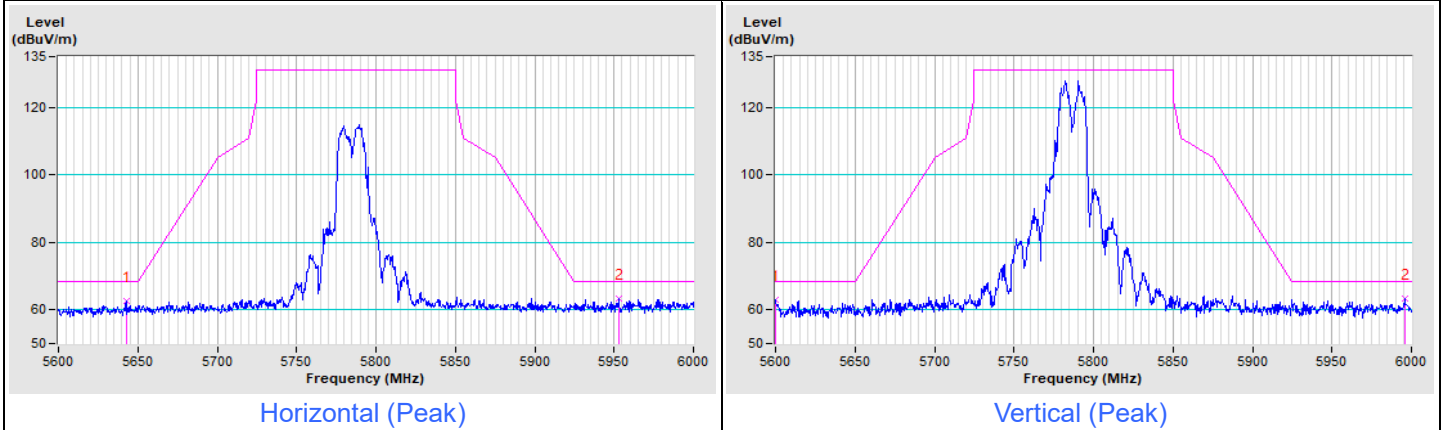

802.11ax (HE20) Channel 165

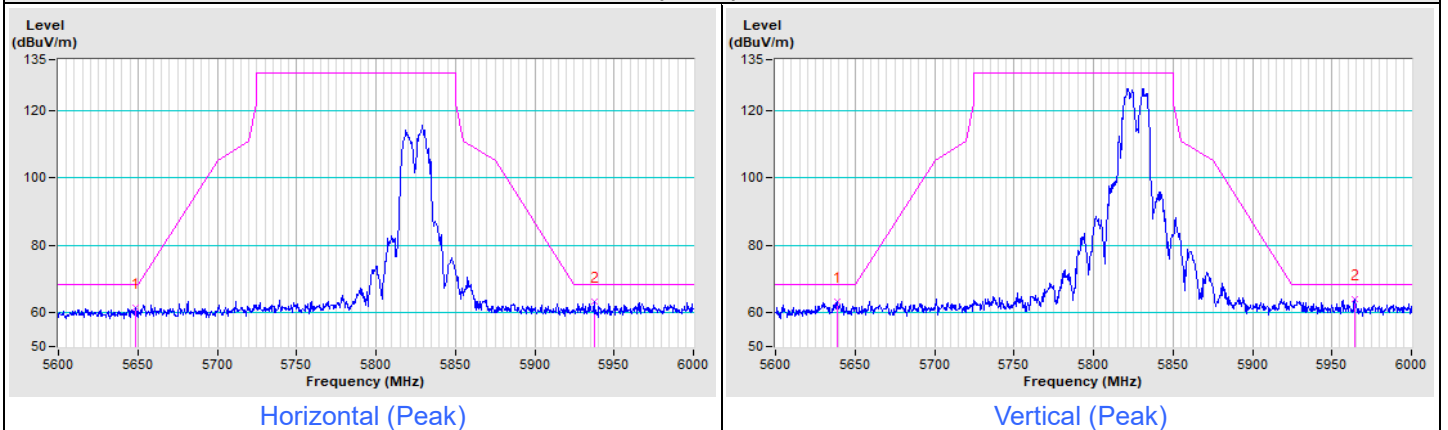

Frequency Range	5.6 GHz ~ 6 GHz	Detector Function & Bandwidth	PK: RB=1 MHz, VB=3 MHz, DET=Peak
-----------------	-----------------	-------------------------------	----------------------------------

802.11ax (HE40) Channel 151

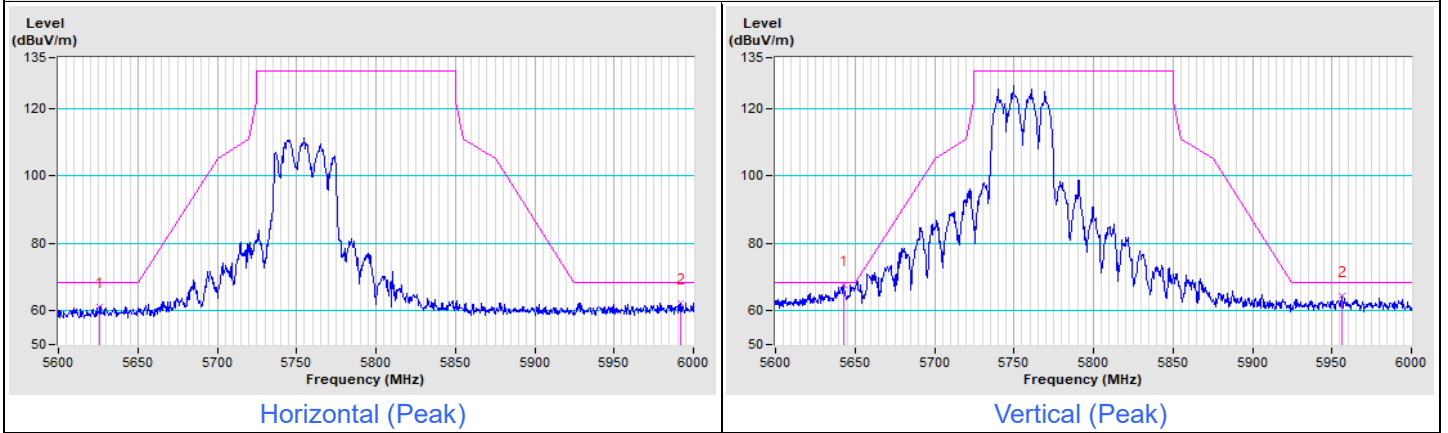

802.11ax (HE40) Channel 159

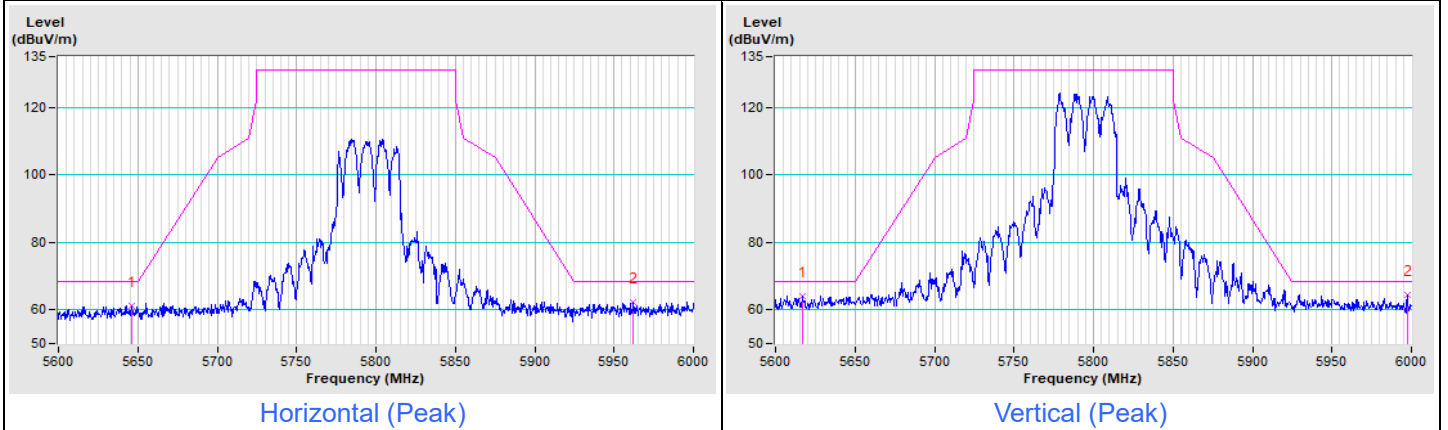

Frequency Range	5.6 GHz ~ 6 GHz	Detector Function & Bandwidth	PK: RB=1 MHz, VB=3 MHz, DET=Peak
-----------------	-----------------	-------------------------------	----------------------------------

802.11ax (HE80) Channel 155

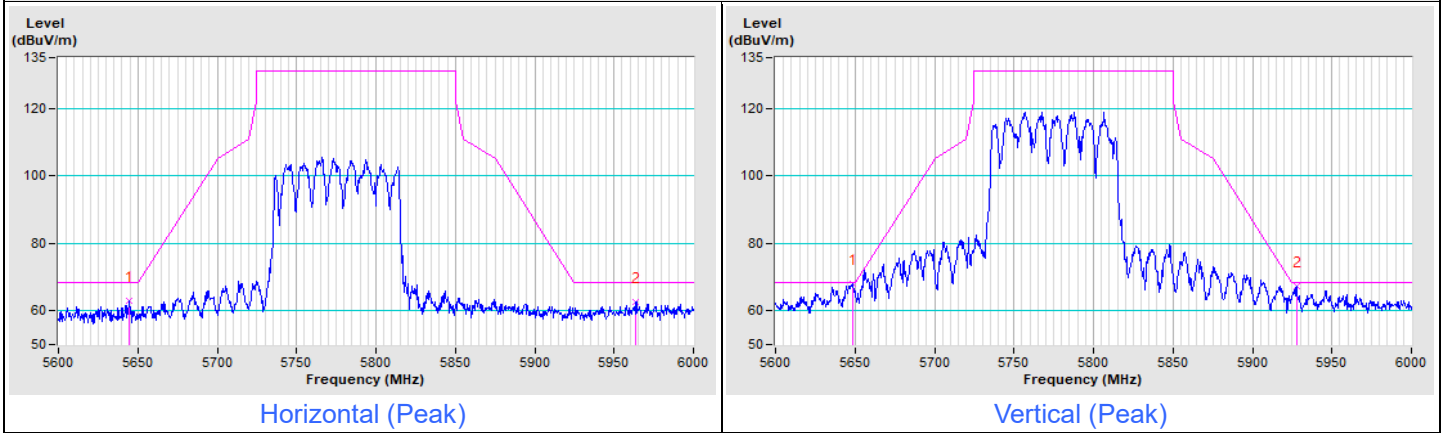

8 Pictures of Test Arrangements

Please refer to the attached file (Test Setup Photo)

9 Information of the Testing Laboratories

We, Bureau Veritas Consumer Products Services (H.K.) Ltd., Taoyuan Branch, were founded in 1988 to provide our best service in EMC, Radio, Telecom and Safety consultation. Our laboratories are FCC recognized accredited test firms and accredited according to ISO/IEC 17025.

If you have any comments, please feel free to contact us at the following:

Lin Kou EMC/RF Lab

Tel: 886-2-26052180

Fax: 886-2-26051924

Hsin Chu EMC/RF/Telecom Lab

Tel: 886-3-6668565

Fax: 886-3-6668323

Hwa Ya EMC/RF/Safety Lab

Tel: 886-3-3183232

Fax: 886-3-3270892

Email: service.adt@bureauveritas.com

Web Site: <http://ee.bureauveritas.com.tw>

The address and road map of all our labs can be found in our web site also.

--- END ---