

FCC Test Report (Co-Located)

Report No.: RF190530C17B-10

FCC ID: H8NCDR8011

Test Model: CDR8010-DBB1

Serial Model: CDR8011-DBA1, CDR8011-DDA1, CDR8011-DDB1, CDR8011-SBA1, CDR8011-SBB1, CDR8011-SDA1, CDR8011-SDB1 (refer to item 3.1 for more details)

Received Date: Feb. 25, 2019

Test Date: Jun. 26 ~ Aug. 28, 2019

Issued Date: Sep. 04, 2019

Applicant: ASKEY COMPUTER CORP.

Address: 10F, NO. 119, JIANKANG RD., ZHONGHE DIST., NEW TAIPEI CITY
23585, TAIWAN, R.O.C.

Issued By: Bureau Veritas Consumer Products Services (H.K.) Ltd., Taoyuan Branch
Lin Kou Laboratories

Lab Address: No. 47-2, 14th Ling, Chia Pau Vil., Lin Kou Dist., New Taipei City, Taiwan
(R.O.C.)

Test Location: No. 19, Hwa Ya 2nd Rd., Wen Hwa Vil., Kwei Shan Dist., Taoyuan City
33383, TAIWAN (R.O.C.)

**FCC Registration/
Designation Number:** 788550 / TW0003



This report is for your exclusive use. Any copying or replication of this report to or for any other person or entity, or use of our name or trademark, is permitted only with our prior written permission. This report sets forth our findings solely with respect to the test samples identified herein. The results set forth in this report are not indicative or representative of the quality or characteristics of the lot from which a test sample was taken or any similar or identical product unless specifically and expressly noted. Our report includes all of the tests requested by you and the results thereof based upon the information that you provided to us. You have 60 days from date of issuance of this report to notify us of any material error or omission caused by our negligence, provided, however, that such notice shall be in writing and shall specifically address the issue you wish to raise. A failure to raise such issue within the prescribed time shall constitute your unqualified acceptance of the completeness of this report, the tests conducted and the correctness of the report contents. Unless specific mention, the uncertainty of measurement has been explicitly taken into account to declare the compliance or non-compliance to the specification. The report must not be used by the client to claim product certification, approval, or endorsement by TAF or any government agencies.

Table of Contents

Release Control Record	3
1 Certificate of Conformity	4
2 Summary of Test Results	5
2.1 Measurement Uncertainty	5
2.2 Test Site and Instruments.....	6
3 General Information	7
3.1 General Description of EUT	7
3.2 Configuration of System under Test.....	9
3.2.1 Description of Support Units.....	10
3.2.2 Test Mode Applicability and Tested Channel Detail.....	11
3.3 General Description of Applied Standards	13
4 Test Types and Results	14
4.1 Radiated Emission Measurement	14
4.1.1 Limits of Radiated Emission Measurement	14
4.1.2 Test Procedure	15
4.1.3 Deviation from Test Standard	16
4.1.4 Test Setup.....	17
4.1.5 Test Results	20
5 Pictures of Test Arrangements	56
Appendix – Information of the Testing Laboratories	57

Release Control Record

Issue No.	Description	Date Issued
RF190530C17B-10	Original release	Sep. 04, 2019

1 Certificate of Conformity

Product: iDVR800

Brand: ASKEY

Test Model: CDR8010-DBB1

Serial Model: CDR8011-DBA1, CDR8011-DDA1, CDR8011-DDB1, CDR8011-SBA1, CDR8011-SBB1, CDR8011-SDA1, CDR8011-SDB1 (refer to item 3.1 for more details)

Sample Status: Engineering sample

Applicant: ASKEY COMPUTER CORP.

Test Date: Jun. 26 ~ Aug. 28, 2019

Standards: 47 CFR FCC Part 15, Subpart C (Section 15.247)
47 CFR FCC Part 15, Subpart E (Section 15.407)
FCC Part 22, Subpart H
FCC Part 24, Subpart E
FCC Part 27, Subpart C, L, H, F
FCC Part 90, Subpart S
ANSI 63.26-2015
ANSI C63.10-2013

The above equipment has been tested by **Bureau Veritas Consumer Products Services (H.K.) Ltd., Taoyuan Branch**, and found compliance with the requirement of the above standards. The test record, data evaluation & Equipment Under Test (EUT) configurations represented herein are true and accurate accounts of the measurements of the sample's RF characteristics under the conditions specified in this report.

Prepared by : Pettie Chen, **Date:** Sep. 04, 2019
Pettie Chen / Senior Specialist

Approved by : Bruce Chen, **Date:** Sep. 04, 2019
Bruce Chen / Senior Project Engineer

2 Summary of Test Results

Applied Standard	47 CFR FCC Part 15, Subpart C (Section 15.247) 47 CFR FCC Part 15, Subpart E (Section 15.407) FCC Part 22, Subpart H FCC Part 24, Subpart E FCC Part 27, Subpart C, L, H, F FCC Part 90, Subpart S ANSI 63.26-2015 ANSI C63.10-2013		
FCC Clause	Test Item	Result	Remarks
2.1046 22.913 (a)	Effective Radiated Power	Pass	Meet the requirement of limit.
2.1046 24.232 (c)	Effective Radiated Power	Pass	Meet the requirement of limit.
2.1046 27.50	Effective Radiated Power	Pass	Meet the requirement of limit.
2.1046 90.635 (b)	Effective Radiated Power	Pass	Meet the requirement of limit.
15.205 / 15.209 / 15.247(d) 15.407(b) (1/2/3/4(ii)/6)	Radiated Emissions	Pass	Meet the requirement of limit. Minimum passing margin is -8.1dB at 2390.00MHz.
2.1053 22.917	Radiated Spurious Emissions	Pass	Meet the requirement of limit. Minimum passing margin is -31.80dB at 1695.00MHz.
2.1053 24.238	Radiated Spurious Emissions	Pass	Meet the requirement of limit. Minimum passing margin is -33.10dB at 3703.00MHz.
2.1053 27.53(a) 27.53(c) 27.53(h) 27.53(m)	Radiated Spurious Emissions	Pass	Meet the requirement of limit. Minimum passing margin is -7.20dB at 1564.00MHz.
2.1053 90.691	Radiated Spurious Emissions	Pass	Meet the requirement of limit. Minimum passing margin is -30.20dB at 1645.00MHz.

Note: Determining compliance based on the results of the compliance measurement, not taking into account measurement instrumentation uncertainty.

2.1 Measurement Uncertainty

Where relevant, the following measurement uncertainty levels have been estimated for tests performed on the EUT as specified in CISPR 16-4-2:

Measurement	Frequency	Expanded Uncertainty (k=2) (\pm)
Radiated Emissions up to 1 GHz	9kHz ~ 30MHz	3.04 dB
	30MHz ~ 200MHz	3.59 dB
	200MHz ~ 1000MHz	3.60 dB
Radiated Emissions above 1 GHz	1GHz ~ 18GHz	2.29 dB
	18GHz ~ 40GHz	2.29 dB

2.2 Test Site and Instruments

Description & Manufacturer	Model No.	Serial No.	Cal. Date	Cal. Due
Test Receiver KEYSIGHT	N9038A	MY55420137	Apr. 15, 2019	Apr. 14, 2020
Spectrum Analyzer ROHDE & SCHWARZ	FSP40	100269	Jun. 04, 2019	Jun. 03, 2020
BILOG Antenna SCHWARZBECK	VULB9168	9168-160	Nov. 21, 2018	Nov. 20, 2019
HORN Antenna SCHWARZBECK	BBHA 9120 D	9120D-1169	Nov. 25, 2018	Nov. 24, 2019
HORN Antenna SCHWARZBECK	BBHA 9170	BBHA9170241	Nov. 25, 2018	Nov. 24, 2019
Preamplifier Agilent (Below 1GHz)	8447D	2944A10638	Aug. 08, 2018	Aug. 07, 2019
			Jul. 11, 2019	Jul. 10, 2020
Preamplifier Agilent (Above 1GHz)	8449B	3008A02367	Feb. 19, 2019	Feb. 18, 2020
RF signal cable HUBER+SUHNER&EMCI	SUCOFLEX 104 & EMC104-SM-SM80 00	CABLE-CH9-02 (248780+171006)	Jan. 19, 2019	Jan. 18, 2020
RF signal cable HUBER+SUHNER	SUCOFLEX 104	CABLE-CH9-(250795/4)	Aug. 08, 2018	Aug. 07, 2019
			Jul. 11, 2019	Jul. 10, 2020
RF signal cable Woken	8D-FB	Cable-CH9-01	Jul. 31, 2018	Jul. 30, 2019
			Jul. 30, 2019	Jul. 29, 2020
Software BV ADT	ADT_Radiated_ V7.6.15.9.5	NA	NA	NA
Antenna Tower EMCO	2070/2080	512.835.4684	NA	NA
Turn Table EMCO	2087-2.03	NA	NA	NA
Antenna Tower & Turn BV ADT	AT100	AT93021705	NA	NA
Turn Table BV ADT	TT100	TT93021705	NA	NA
Turn Table Controller BV ADT	SC100	SC93021705	NA	NA
Boresight Antenna Fixture	FBA-01	FBA-SIP01	NA	NA
Pre-amplifier (18GHz-40GHz) EMC	EMC184045B	980175	Nov. 14, 2018	Nov. 13, 2019
WIT Standard Temperature And Humidity Chamber	TH-4S-C	W981030	Jun. 03, 2019	Jun. 02, 2020
JFW 20dB attenuation	50HF-020-SMA	NA	NA	NA

Note: 1. The calibration interval of the above test instruments is 12 months and the calibrations are traceable to NML/ROC and NIST/USA.
2. The test was performed in HwaYa Chamber 9.

3 General Information

3.1 General Description of EUT

Product	iDVR800			
Brand	ASKEY			
Test Model	CDR8010-DBB1			
Serial Model	CDR8011-DBA1, CDR8011-DDA1, CDR8011-DDB1, CDR8011-SBA1, CDR8011-SBB1, CDR8011-SDA1, CDR8011-SDB1			
Model Difference	Refer to Note			
Status of EUT	Engineering sample			
Power Supply Rating	12Vdc / 24Vdc (Car Charger) 3.7Vdc (Battery)			
Modulation Type	WLAN	CCK, DQPSK, DBPSK for DSSS 256QAM, 64QAM, 16QAM, QPSK, BPSK for OFDM		
	BT EDR	GFSK, $\pi/4$ -DQPSK, 8DPSK		
	BT LE	GFSK		
	NFC	ASK		
	LTE	QPSK, 16QAM		
Operating Frequency	WLAN	2412 ~ 2462MHz, 5180 ~ 5240MHz, 5260 ~ 5320MHz, 5500 ~ 5700MHz, 5745 ~ 5825MHz		
	BT EDR	2402~2480MHz		
	BT LE	2402~2480MHz		
	NFC	13.56MHz		
	LTE	LTE Band 2	Channel Bandwidth 1.4MHz	1850.7MHz ~ 1909.3MHz
			Channel Bandwidth 3MHz	1851.5MHz ~ 1908.5MHz
			Channel Bandwidth 5MHz	1852.5MHz ~ 1907.5MHz
			Channel Bandwidth 10MHz	1855.0MHz ~ 1905.0MHz
			Channel Bandwidth 15MHz	1857.5MHz ~ 1902.5MHz
			Channel Bandwidth 20MHz	1860.0MHz ~ 1900.0MHz
		LTE Band 4	Channel Bandwidth 1.4MHz	1710.7MHz ~ 1754.3MHz
			Channel Bandwidth 3MHz	1711.5MHz ~ 1753.5MHz
			Channel Bandwidth 5MHz	1712.5MHz ~ 1752.5MHz
			Channel Bandwidth 10MHz	1715.0MHz ~ 1750.0MHz
			Channel Bandwidth 15MHz	1717.5MHz ~ 1747.5MHz
			Channel Bandwidth 20MHz	1720.0MHz ~ 1745.0MHz
		LTE Band 5	Channel Bandwidth 1.4MHz	824.7MHz ~ 848.3MHz
			Channel Bandwidth 3MHz	825.5MHz ~ 847.5MHz
			Channel Bandwidth 5MHz	826.5MHz ~ 846.5MHz
			Channel Bandwidth 10MHz	829.0MHz ~ 844.0MHz
LTE Band 12		Channel Bandwidth 1.4MHz	699.7MHz ~ 715.3MHz	
		Channel Bandwidth 3MHz	700.5MHz ~ 714.5MHz	
	Channel Bandwidth 5MHz	701.5MHz ~ 713.5MHz		
	Channel Bandwidth 10MHz	704.0MHz ~ 711.0MHz		
LTE Band 13	Channel Bandwidth 5MHz	779.5MHz ~ 784.5MHz		
	Channel Bandwidth 10MHz	782.0MHz		

Operating Frequency	LTE	LTE Band 17	Channel Bandwidth 5MHz	706.5MHz ~ 713.5MHz
			Channel Bandwidth 10MHz	709.0MHz ~ 711.0MHz
		LTE Band 26 (Part 22)	Channel Bandwidth 1.4MHz	824.7 ~ 848.3MHz
			Channel Bandwidth 3MHz	825.5 ~ 847.5MHz
			Channel Bandwidth 5MHz	826.5 ~ 846.5MHz
			Channel Bandwidth 10MHz	829.0 ~ 844.0MHz
			Channel Bandwidth 15MHz	831.5 ~ 841.5MHz
		LTE Band 26 (Part 90S)	Channel Bandwidth 1.4MHz	814.7 ~ 823.3MHz
			Channel Bandwidth 3MHz	815.5 ~ 822.5MHz
			Channel Bandwidth 5MHz	816.5 ~ 821.5MHz
			Channel Bandwidth 10MHz	819.0MHz
		Antenna Type	Refer to Note as below	
Antenna Connector	Refer to Note as below			
Accessory Device	Car charger, SD Card			
Data Cable Supplied	NA			

Note:

1. All models are listed as below. Model CDR8010-DBB1 is the representative for final test.

Model	PCB	Camera	NFC	Fan	eSIM	RAM
CDR8010-DBB1	Same PCB	Dual	Yes	Yes	N/A	3GB
CDR8011-DBA1			Yes	Yes		N/A
CDR8011-DDA1			Yes	No		N/A
CDR8011-DDB1			Yes	No		3GB
CDR8011-SBA1		Single	Yes	Yes		N/A
CDR8011-SBB1			Yes	Yes		3GB
CDR8011-SDA1			Yes	No		N/A
CDR8011-SDB1			Yes	No		3GB

2. The EUT is powered by the following car charger and battery.

Car charger	
Brand	Sunny
Model	SYD1202-1005
Input Power	12Vdc / 24Vdc, 1.5A
Output Power	5Vdc, 2.1A
Power Line	5.1m cable with USB Type C connector

Battery	
Brand	FUJI ELECTRONICS(SHENZHEN)CO., LTD
Model	ICP463048XS
Rating	3.7Vdc, 750mA

3. The following antennas were provided to the EUT.

Antenna Type	PIFA					
Connector Type	I-PEX					
Brand	WHAYU					
Model	C407-510916-A					
Antenna gain (dBi)						
2400MHz	2450MHz	2500MHz	5150MHz	5350MHz	5725MHz	5825MHz
1.32	-0.68	-0.46	3.39	-0.04	3.44	2.40

Ant. No.	Type	Connector	Gain (dBi)							
			LTE B2	LTE B4	LTE B5	LTE B12	LTE B13	LTE B17	LTE B26 (Part 22)	LTE B26 (Part 90S)
Main	PIFA	I-PEX	2.04	1.51	-0.70	-4.02	-1.88	-4.02	-0.70	-1.25
Aux. (RX only)	PIFA	I-PEX	-1.79	0.35	0.01	-6.18	-2.44	-6.56	0.01	0.11

3.2 Configuration of System under Test

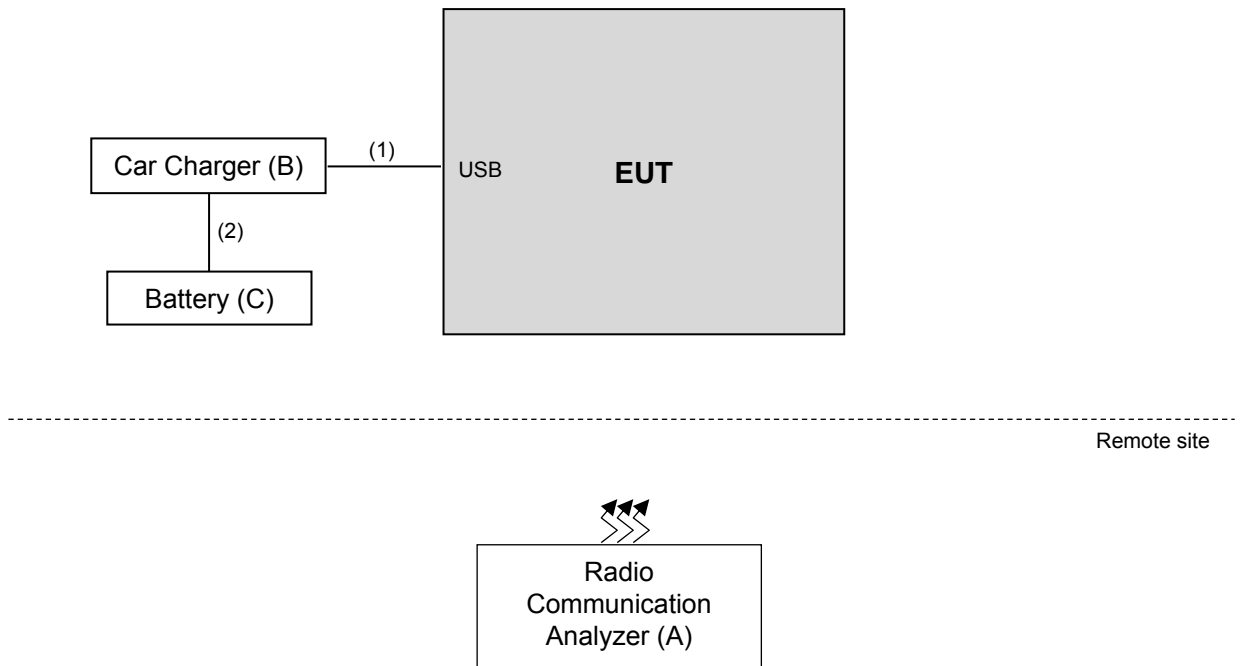

3.2.1 Description of Support Units

The EUT has been tested as an independent unit together with other necessary accessories or support units. The following support units or accessories were used to form a representative test configuration during the tests.

ID	Product	Brand	Model No.	Serial No.	FCC ID	Remarks
A.	Radio Communication Analyzer	Anritsu	MT8860C	1702001	NA	-
B.	Car Charger	Sunny	SYD1202-1005	NA	NA	Accessory of EUT
C.	Battery	YUASA	ST-CLN126-6S	NA	NA	-

Note:

1. All power cords of the above support units are non-shielded (1.8m).
2. Item A acted as a communication partner to transfer data.

ID	Descriptions	Qty.	Length (m)	Shielding (Yes/No)	Cores (Qty.)	Remarks
1.	Type C to car charger	1	5.1	N	0	Accessory of EUT
2.	DC cable	1	1	N	0	-

3.2.2 Test Mode Applicability and Tested Channel Detail

EUT CONFIGURE MODE	Test item	MODE	FREQ. RANGE (MHz)	AVAILABLE CHANNEL	TESTED CHANNEL
	Radiated Emission Below 1GHz	LTE Band 2 (BW: 3MHz) + 802.11g	1851.5~1908.5	18615 to 19185	18615+6
			2412~2462	1 to 11	
		LTE Band 2 (BW: 3MHz) + 802.11n (HT20)	1851.5~1908.5	18615 to 19185	18615+48
			5180~5240	36 to 48	
			5260~5320	52 to 64	
			5500~5700 5745~5825	100 to 140 149 to 165	
		LTE Band 2 (BW: 3MHz) + BT LE	1851.5~1908.5	18615 to 19185	18615+0
			2402~2480	0 to 39	
		LTE Band 13 (BW: 5MHz) + 802.11g	779.5 ~ 784.5	23205 to 23255	23230+6
			2412~2462	1 to 11	
		LTE Band 13 (BW: 5MHz) + 802.11n (HT20)	779.5 ~ 784.5	23205 to 23255	23230+48
			5180~5240	36 to 48	
			5260~5320	52 to 64	
			5500~5700 5745~5825	100 to 140 149 to 165	
		LTE Band 13 (BW: 5MHz) + BT LE	779.5 ~ 784.5	23205 to 23255	23230+0
			2402~2480	0 to 39	
		LTE Band 26 (BW: 3MHz) + 802.11g	825.5~847.5	26805 to 27025	27025+6
			2412~2462	1 to 11	
LTE Band 26 (BW: 3MHz) + 802.11n (HT20)	825.5~847.5	26805 to 27025	27025+48		
	5180~5240	36 to 48			
	5260~5320	52 to 64			
	5500~5700 5745~5825	100 to 140 149 to 165			
LTE Band 26 (BW: 3MHz) + BT LE	825.5~847.5	26805 to 27025	27025+0		
	2402~2480	0 to 39			
LTE Band 26 (BW: 3MHz) + 802.11g	815.5~822.5	26705 to 26775	26775+6		
	2412~2462	1 to 11			
LTE Band 26 (BW: 3MHz) + 802.11n (HT20)	815.5~822.5	26705 to 26775	26775+48		
	5180~5240	36 to 48			
	5260~5320	52 to 64			
	5500~5700 5745~5825	100 to 140 149 to 165			
LTE Band 26 (BW: 3MHz) + BT LE	815.5~822.5	26705 to 26775	26775+0		
	2402~2480	0 to 39			

EUT CONFIGURE MODE	Test item	MODE	FREQ. RANGE (MHz)	AVAILABLE CHANNEL	TESTED CHANNEL
	Radiated Emission Above 1GHz	LTE Band 2 (BW: 3MHz) + 802.11g	1851.5~1908.5	18615 to 19185	18615+6
			2412~2462	1 to 11	
		LTE Band 2 (BW: 3MHz) + 802.11n (HT20)	1851.5~1908.5	18615 to 19185	18615+48
			5180~5240	36 to 48	
			5260~5320	52 to 64	
			5500~5700	100 to 140	
		LTE Band 2 (BW: 3MHz) + BT LE	5745~5825	149 to 165	18615+0
			1851.5~1908.5	18615 to 19185	
		LTE Band 13 (BW: 5MHz) + 802.11g	2402~2480	0 to 39	23230+6
			779.5 ~ 784.5	23205 to 23255	
		LTE Band 13 (BW: 5MHz) + 802.11n (HT20)	2412~2462	1 to 11	23230+48
			779.5 ~ 784.5	23205 to 23255	
			5180~5240	36 to 48	
			5260~5320	52 to 64	
		LTE Band 13 (BW: 5MHz) + BT LE	5500~5700	100 to 140	23230+0
			5745~5825	149 to 165	
LTE Band 26 (BW: 3MHz) + 802.11g	779.5 ~ 784.5	23205 to 23255	27025+6		
	825.5~847.5	26805 to 27025			
LTE Band 26 (BW: 3MHz) + 802.11n (HT20)	2412~2462	1 to 11	27025+48		
	825.5~847.5	26805 to 27025			
	5180~5240	36 to 48			
	5260~5320	52 to 64			
LTE Band 26 (BW: 3MHz) + BT LE	5500~5700	100 to 140	27025+0		
	5745~5825	149 to 165			
LTE Band 26 (BW: 3MHz) + 802.11g	825.5~847.5	26805 to 27025	26775+6		
	2402~2480	0 to 39			
LTE Band 26 (BW: 3MHz) + 802.11n (HT20)	815.5~822.5	26705 to 26775	26775+48		
	2412~2462	1 to 11			
	815.5~822.5	26705 to 26775			
	5180~5240	36 to 48			
LTE Band 26 (BW: 3MHz) + BT LE	5260~5320	52 to 64	26775+0		
	5500~5700	100 to 140			
LTE Band 26 (BW: 3MHz) + 802.11g	5745~5825	149 to 165	26775+0		
	815.5~822.5	26705 to 26775			
LTE Band 26 (BW: 3MHz) + BT LE	2402~2480	0 to 39	26775+0		
	2402~2480	0 to 39			

Test Condition:

Test Item	Environmental Conditions	Input Power (system)	Tested By
Radiated Emission	25deg. C, 70%RH	120Vac, 60Hz	Greg Lin

3.3 General Description of Applied Standards

The EUT is a RF Product. According to the specification of the EUT declared by the manufacturer, it must comply with the requirements of the following standards:

47 CFR FCC Part 15, Subpart C (Section 15.247)
47 CFR FCC Part 15, Subpart E (Section 15.407)
FCC Part 22, Subpart H
FCC Part 24, Subpart E
FCC Part 27, Subpart C, L, H, F
FCC Part 90, Subpart S
ANSI 63.26-2015
ANSI C63.10-2013

All test items have been performed and recorded as per the above standards.

4 Test Types and Results

4.1 Radiated Emission Measurement

4.1.1 Limits of Radiated Emission Measurement

For WLAN, BT LE:

Radiated emissions which fall in the restricted bands must comply with the radiated emission limits specified as below table. Other emissions shall be at least 30dB below the highest level of the desired power:

Frequencies (MHz)	Field Strength (microvolts/meter)	Measurement Distance (meters)
0.009 ~ 0.490	2400/F(kHz)	300
0.490 ~ 1.705	24000/F(kHz)	30
1.705 ~ 30.0	30	30
30 ~ 88	100	3
88 ~ 216	150	3
216 ~ 960	200	3
Above 960	500	3

Note:

1. The lower limit shall apply at the transition frequencies.
2. Emission level (dBuV/m) = 20 log Emission level (uV/m).
3. For frequencies above 1000MHz, the field strength limits are based on average detector, however, the peak field strength of any emission shall not exceed the maximum permitted average limits, specified above by more than 20dB under any condition of modulation.

For LTE Band 2, Band 26:

Out of band emissions, the power of any emission outside of the authorized operating frequency ranges must be attenuated below the transmitting power by a factor of at least $43 + 10 \log (P)$ dB, so the limit level is:
 $P(\text{dBm}) - (43 + 10 \log(P)) \text{ dB} = -13\text{dBm}$

For LTE Band 13:

According to FCC 27.53(c)(2) for on any frequency outside the 776-788 MHz band, the power of any emission shall be attenuated outside the band below the transmitter power (P) by at least $43 + 10 \log (P)$ dB.
 For operations in the 775-788 MHz, emissions in the band 1559-1610 MHz shall be limited to -70 dBW/MHz. The limit of emissions is equal to -40 dBm.

4.1.2 Test Procedure

For WLAN, BT LE:

For Radiated emission below 30MHz

- a. The EUT was placed on the top of a rotating table 0.8 meters above the ground at a 3 meter chamber room. The table was rotated 360 degrees to determine the position of the highest radiation.
- b. The EUT was set 3 meters away from the interference-receiving antenna, which was mounted on the top of a variable-height antenna tower.
- c. Parallel, perpendicular, and ground-parallel orientations of the antenna are set to make the measurement.
- d. For each suspected emission, the EUT was arranged to its worst case and the rotatable table was turned from 0 degrees to 360 degrees to find the maximum reading.
- e. The test-receiver system was set to Quasi-Peak Detect Function and Specified Bandwidth with Maximum Hold Mode.

Note:

1. The resolution bandwidth and video bandwidth of test receiver/spectrum analyzer is 9kHz at frequency below 30MHz.

For Radiated emission above 30MHz

- a. The EUT was placed on the top of a rotating table 0.8 meters (for 30MHz ~ 1GHz) / 1.5 meters (for above 1GHz) above the ground at 3 meter chamber room for test. The table was rotated 360 degrees to determine the position of the highest radiation.
- b. The EUT was set 3 meters away from the interference-receiving antenna, which was mounted on the top of a variable-height antenna tower.
- c. The height of antenna is varied from one meter to four meters above the ground to determine the maximum value of the field strength. Both horizontal and vertical polarizations of the antenna are set to make the measurement.
- d. For each suspected emission, the EUT was arranged to its worst case and then the antenna was tuned to heights from 1 meter to 4 meters and the rotatable table was turned from 0 degrees to 360 degrees to find the maximum reading.
- e. The test-receiver system was set to quasi-peak detect function and specified bandwidth with maximum hold mode when the test frequency is below 1 GHz.
- f. The test-receiver system was set to peak and average detect function and specified bandwidth with maximum hold mode when the test frequency is above 1 GHz. If the peak reading value also meets average limit, measurement with the average detector is unnecessary.

Note:

1. The resolution bandwidth and video bandwidth of test receiver/spectrum analyzer is 120kHz for Quasi-peak detection (QP) at frequency below 1GHz.
2. The resolution bandwidth of test receiver/spectrum analyzer is 1 MHz and the video bandwidth is 3 MHz for Peak detection (PK) at frequency above 1GHz.
3. The resolution bandwidth of test receiver/spectrum analyzer is 1MHz and the video bandwidth is $\geq 1/T$ (Duty cycle < 98%) or 10Hz (Duty cycle $\geq 98\%$) for Average detection (AV) at frequency above 1GHz.
4. All modes of operation were investigated and the worst-case emissions are reported.

For LTE Band 2, Band 13, Band 26:

- a. The power was measured with R&S Spectrum Analyzer. All measurements were done at 3 channels (low, middle and high channel of operational frequency range.)
- b. Substitution method is used for E.I.R.P measurement. In the semi-anechoic chamber, EUT placed on the 0.8m height of Turn Table, rotated the table around 360 degrees to search the maximum radiation power and receiver antenna shall be rotated vertical and horizontal polarization and moved height from 1m to 4m to find the maximum polar radiated power. The “Read Value” is the spectrum reading the maximum power value.
- c. The substitution antenna is substituted for EUT at the same position and signals generator export the CW signal to the substitution antenna via a TX cable. Rotated the Turn Table and moved receiving antenna to find the maximum radiation power. Adjust output power level of S.G to get a Value of spectrum reading equal to “Read Value” of step b. Record the power level of S.G
- d. $EIRP = \text{Output power level of S.G} - \text{TX cable loss} + \text{Antenna gain of substitution antenna}$.

Note: The resolution bandwidth and video bandwidth of test receiver/spectrum analyzer is 1MHz/3MHz.

4.1.3 Deviation from Test Standard

No deviation.

4.1.4 Test Setup

For WLAN, BT LE:

For Radiated emission below 30MHz

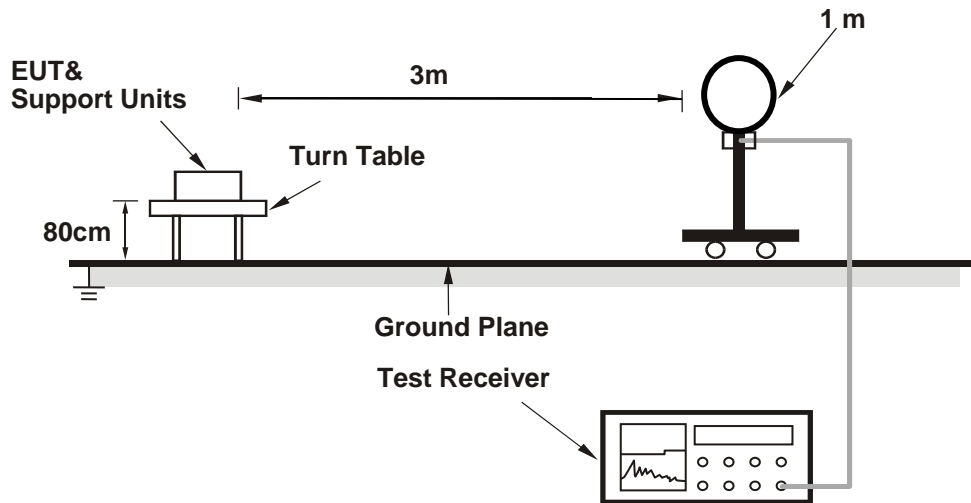

For Radiated emission 30MHz to 1GHz

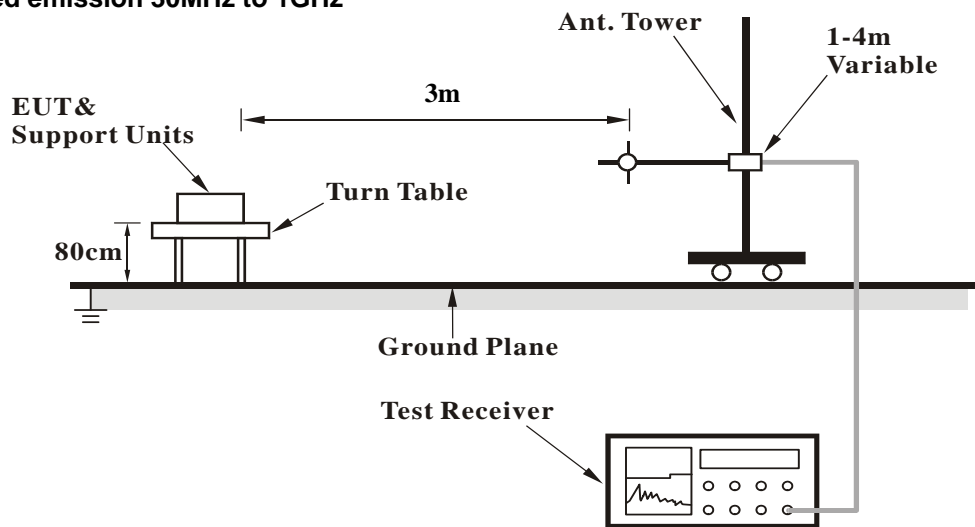

For Radiated emission above 1GHz

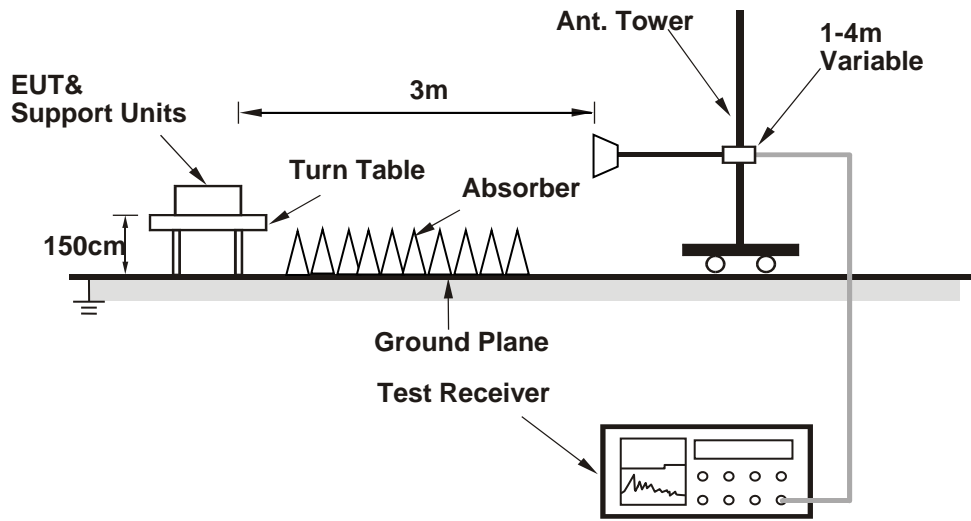

For the actual test configuration, please refer to the attached file (Test Setup Photo).

For LTE Band 2, Band 13, Band 26:

For Radiated Emission below or equal 1GHz

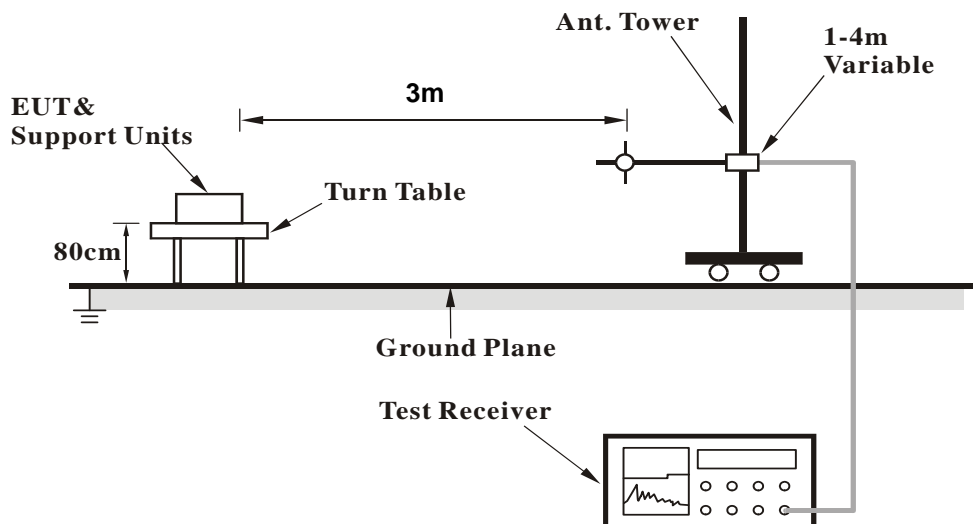

For Radiated Emission above 1GHz

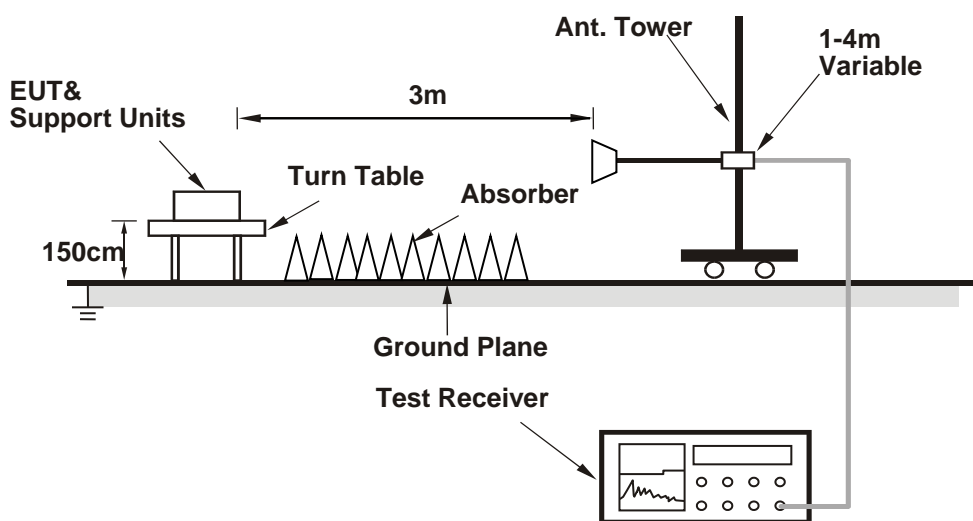

For the actual test configuration, please refer to the attached file (Test Setup Photo).

4.1.5 Test Results

Below 1GHz Data:

LTE Band 2 (BW: 3MHz) CH18615 + 802.11g CH 6

Mode	TX channel 18615+6	Frequency Range	Below 1000 MHz
------	--------------------	-----------------	----------------

Antenna Polarity & Test Distance: Horizontal at 3 m							
No.	Freq. (MHz)	Reading (dBm)	S.G Power Value (dBm)	Correction Factor (dB)	EIRP (dBm)	Limit (dBm)	Margin (dB)
1	35.62	-54.6	-35.2	-16.0	-51.2	-13.0	-38.2
2	97.48	-56.3	-63.9	-1.2	-65.1	-13.0	-52.1
3	194.48	-44.1	-50.0	-2.6	-52.6	-13.0	-39.6
4	259.14	-53.2	-56.6	-1.5	-58.1	-13.0	-45.1
5	419.41	-68.6	-72.3	3.5	-68.8	-13.0	-55.8
6	814.43	-70.5	-68.4	3.9	-64.5	-13.0	-51.5

Remarks:

1. EIRP (dBm) = S.G Value (dBm) + Correction Factor (dB).
2. Correction Factor (dB) = Substitution Antenna Gain (dB) + Cable Loss (dB).

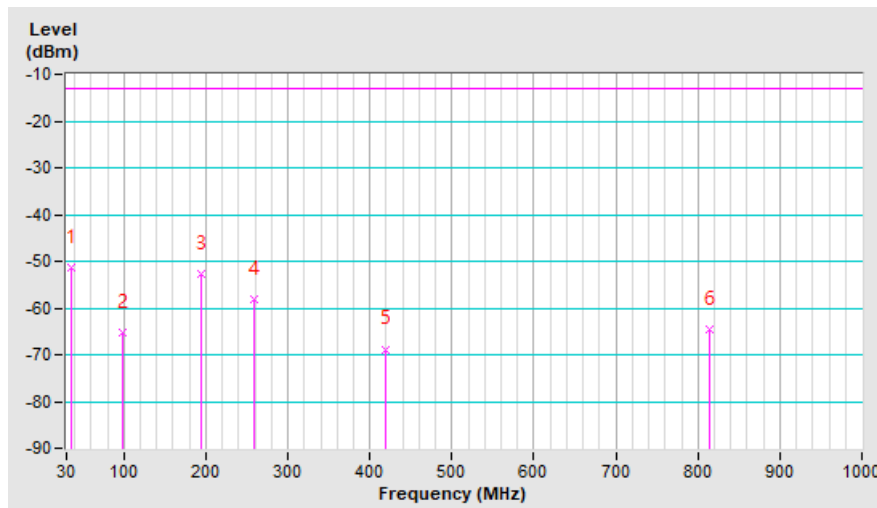

Mode	TX channel 18615+6	Frequency Range	Below 1000 MHz
------	--------------------	-----------------	----------------

Antenna Polarity & Test Distance: Vertical at 3 m							
No.	Freq. (MHz)	Reading (dBm)	S.G Power Value (dBm)	Correction Factor (dB)	EIRP (dBm)	Limit (dBm)	Margin (dB)
1	38.43	-46.7	-41.8	-14.3	-56.1	-13.0	-43.1
2	142.46	-66.1	-65.3	-3.0	-68.3	-13.0	-55.3
3	184.64	-52.7	-52.9	-2.9	-55.8	-13.0	-42.8
4	250.71	-59.3	-58.0	-1.3	-59.3	-13.0	-46.3
5	572.64	-68.2	-70.2	3.7	-66.5	-13.0	-53.5
6	897.38	-71.2	-66.4	3.5	-62.9	-13.0	-49.9

Remarks:

1. EIRP (dBm) = S.G Value (dBm) + Correction Factor (dB).
2. Correction Factor (dB) = Substitution Antenna Gain (dB) + Cable Loss (dB).

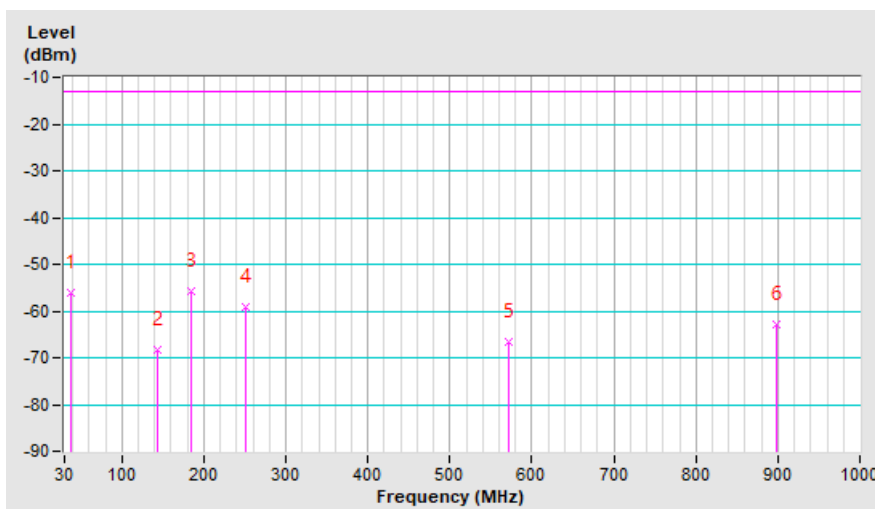

LTE Band 2 (BW: 3MHz) CH18615 + 802.11n (HT20) CH 48

Mode	TX channel 18615+48	Frequency Range	Below 1000 MHz
------	---------------------	-----------------	----------------

Antenna Polarity & Test Distance: Horizontal at 3 m							
No.	Freq. (MHz)	Reading (dBm)	S.G Power Value (dBm)	Correction Factor (dB)	EIRP (dBm)	Limit (dBm)	Margin (dB)
1	32.81	-43.9	-22.9	-17.8	-40.7	-13.0	-27.7
2	82.01	-56.8	-62.5	0.5	-62.0	-13.0	-49.0
3	177.61	-44.7	-49.6	-3.0	-52.6	-13.0	-39.6
4	247.90	-48.7	-53.9	-1.5	-55.4	-13.0	-42.4
5	375.83	-65.4	-70.9	3.7	-67.2	-13.0	-54.2
6	924.09	-71.0	-66.4	3.6	-62.8	-13.0	-49.8

Remarks:

1. EIRP (dBm) = S.G Value (dBm) + Correction Factor (dB).
2. Correction Factor (dB) = Substitution Antenna Gain (dB) + Cable Loss (dB).

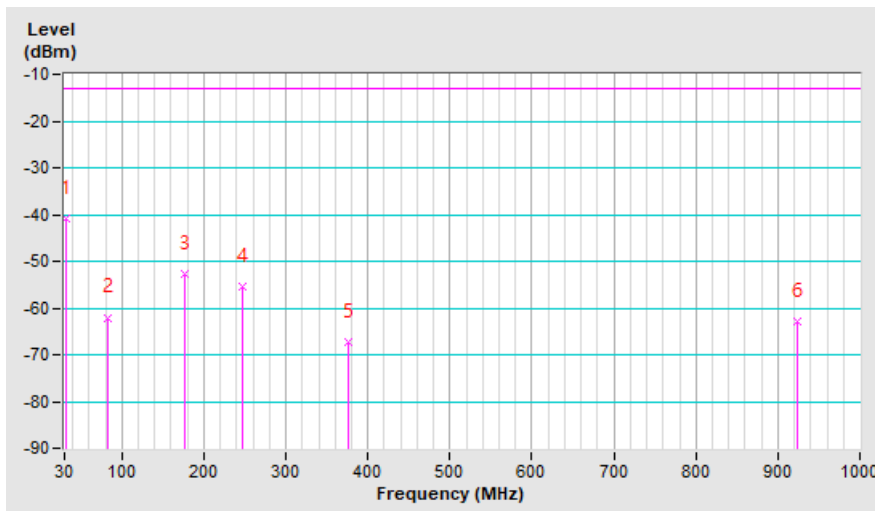

Mode	TX channel 18615+48	Frequency Range	Below 1000 MHz
------	---------------------	-----------------	----------------

Antenna Polarity & Test Distance: Vertical at 3 m							
No.	Freq. (MHz)	Reading (dBm)	S.G Power Value (dBm)	Correction Factor (dB)	EIRP (dBm)	Limit (dBm)	Margin (dB)
1	39.84	-49.1	-45.1	-13.7	-58.8	-13.0	-45.8
2	142.46	-66.1	-65.3	-3.0	-68.3	-13.0	-55.3
3	261.96	-59.7	-57.0	-1.6	-58.6	-13.0	-45.6
4	385.67	-67.3	-71.3	3.5	-67.8	-13.0	-54.8
5	607.78	-67.6	-66.9	3.6	-63.3	-13.0	-50.3
6	893.16	-70.7	-65.9	3.5	-62.4	-13.0	-49.4

Remarks:

1. EIRP (dBm) = S.G Value (dBm) + Correction Factor (dB).
2. Correction Factor (dB) = Substitution Antenna Gain (dB) + Cable Loss (dB).

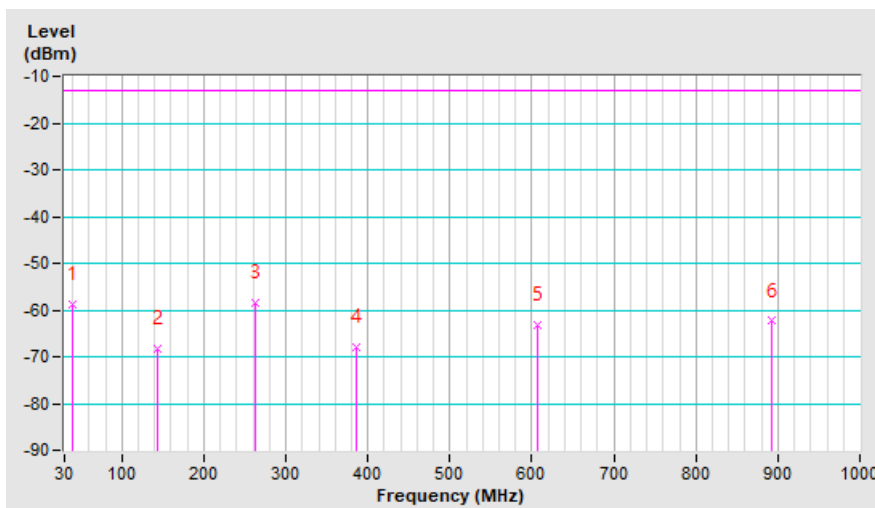

LTE Band 2 (BW: 3MHz) CH18615 + BT LE CH 0

Mode	TX channel 18615+0	Frequency Range	Below 1000 MHz
------	--------------------	-----------------	----------------

Antenna Polarity & Test Distance: Horizontal at 3 m							
No.	Freq. (MHz)	Reading (dBm)	S.G Power Value (dBm)	Correction Factor (dB)	EIRP (dBm)	Limit (dBm)	Margin (dB)
1	37.03	-57.0	-38.5	-15.1	-53.6	-13.0	-40.6
2	72.17	-53.3	-59.2	-0.2	-59.4	-13.0	-46.4
3	204.32	-43.4	-49.4	-2.0	-51.4	-13.0	-38.4
4	298.51	-60.1	-62.9	-0.4	-63.3	-13.0	-50.3
5	450.33	-68.6	-72.1	3.4	-68.7	-13.0	-55.7
6	886.13	-70.2	-66.4	3.4	-63.0	-13.0	-50.0

Remarks:

1. EIRP (dBm) = S.G Value (dBm) + Correction Factor (dB).
2. Correction Factor (dB) = Substitution Antenna Gain (dB) + Cable Loss (dB).

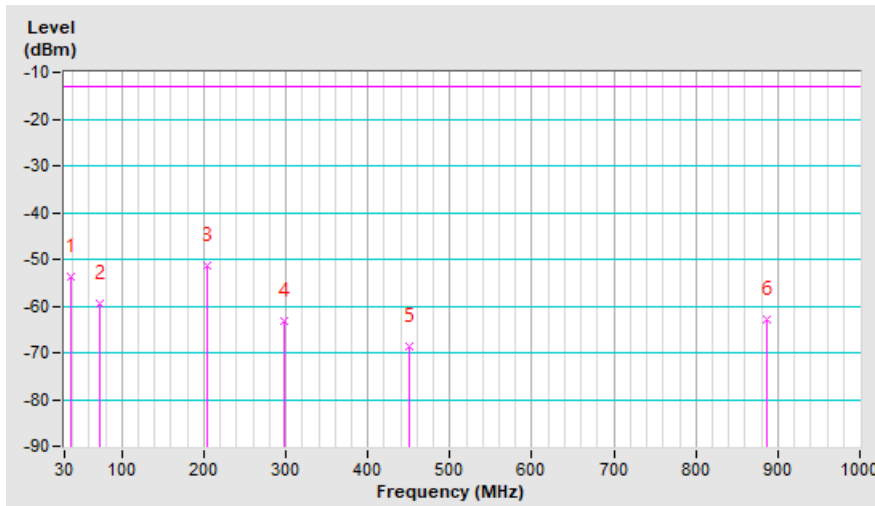

Mode	TX channel 18615+0	Frequency Range	Below 1000 MHz
------	--------------------	-----------------	----------------

Antenna Polarity & Test Distance: Vertical at 3 m							
No.	Freq. (MHz)	Reading (dBm)	S.G Power Value (dBm)	Correction Factor (dB)	EIRP (dBm)	Limit (dBm)	Margin (dB)
1	35.62	-41.1	-34.9	-16.0	-50.9	-13.0	-37.9
2	91.86	-61.1	-67.4	-0.5	-67.9	-13.0	-54.9
3	215.57	-49.7	-51.4	-2.0	-53.4	-13.0	-40.4
4	273.20	-62.4	-58.4	-1.5	-59.9	-13.0	-46.9
5	534.68	-68.1	-70.7	3.8	-66.9	-13.0	-53.9
6	932.52	-70.9	-65.8	3.7	-62.1	-13.0	-49.1

Remarks:

1. EIRP (dBm) = S.G Value (dBm) + Correction Factor (dB).
2. Correction Factor (dB) = Substitution Antenna Gain (dB) + Cable Loss (dB).

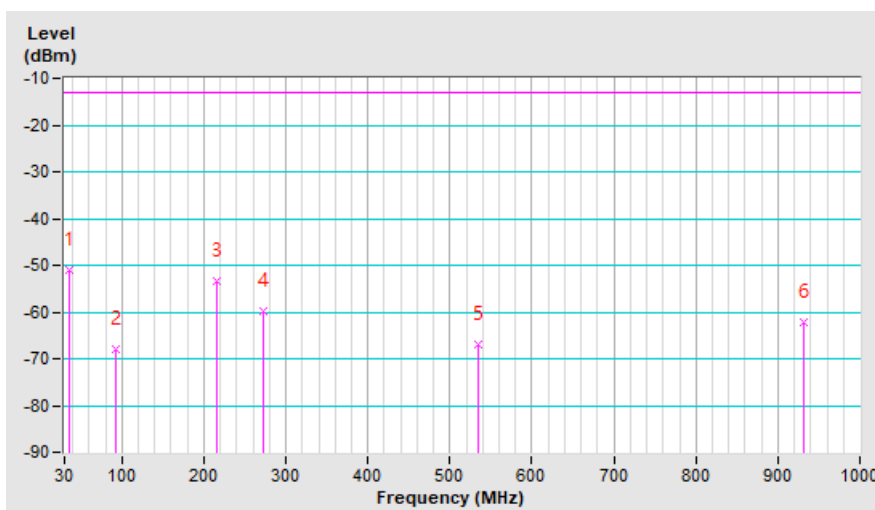

LTE Band 13 (BW: 5MHz) CH23230 + 802.11g CH 6

Mode	TX channel 23230+6	Frequency Range	Below 1000 MHz
------	--------------------	-----------------	----------------

Antenna Polarity & Test Distance: Horizontal at 3 m							
No.	Freq. (MHz)	Reading (dBm)	S.G Power Value (dBm)	Correction Factor (dB)	ERP (dBm)	Limit (dBm)	Margin (dB)
1	39.70	-64.7	-50.8	-13.7	-64.5	-13.0	-51.5
2	187.14	-45.6	-53.3	-2.7	-56.0	-13.0	-43.0
3	303.54	-58.4	-68.7	3.7	-65.0	-13.0	-52.0
4	555.74	-64.2	-69.6	3.7	-65.9	-13.0	-52.9
5	800.18	-64.0	-64.6	4.0	-60.6	-13.0	-47.6
6	912.70	-65.0	-63.1	3.6	-59.5	-13.0	-46.5

Remarks:

1. ERP (dBm) = S.G Value (dBm) + Correction Factor (dB).
2. Correction Factor (dB) = Substitution Antenna Gain (dB) + Cable Loss (dB).

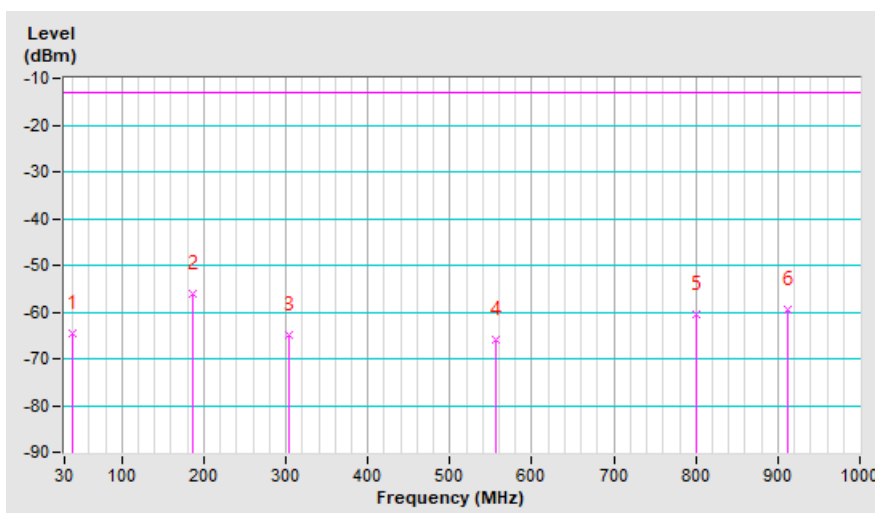

Mode	TX channel 23230+6	Frequency Range	Below 1000 MHz
------	--------------------	-----------------	----------------

Antenna Polarity & Test Distance: Vertical at 3 m							
No.	Freq. (MHz)	Reading (dBm)	S.G Power Value (dBm)	Correction Factor (dB)	ERP (dBm)	Limit (dBm)	Margin (dB)
1	64.92	-56.2	-61.3	-1.9	-63.2	-13.0	-50.2
2	163.86	-56.1	-56.3	-2.9	-59.2	-13.0	-46.2
3	266.68	-60.0	-57.1	-1.6	-58.7	-13.0	-45.7
4	394.72	-64.1	-68.1	3.3	-64.8	-13.0	-51.8
5	528.58	-70.5	-73.5	3.9	-69.6	-13.0	-56.6
6	722.58	-67.0	-64.3	3.6	-60.7	-13.0	-47.7

Remarks:

1. ERP (dBm) = S.G Value (dBm) + Correction Factor (dB).
2. Correction Factor (dB) = Substitution Antenna Gain (dB) + Cable Loss (dB).

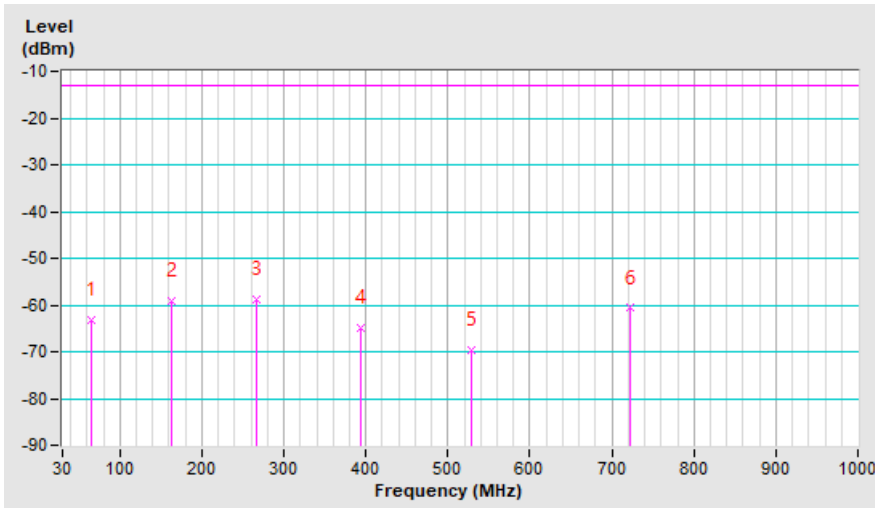

LTE Band 13 (BW: 5MHz) CH23230 + 802.11n (HT20) CH 48

Mode	TX channel 23230+48	Frequency Range	Below 1000 MHz
------	---------------------	-----------------	----------------

Antenna Polarity & Test Distance: Horizontal at 3 m							
No.	Freq. (MHz)	Reading (dBm)	S.G Power Value (dBm)	Correction Factor (dB)	ERP (dBm)	Limit (dBm)	Margin (dB)
1	138.64	-58.1	-63.0	-3.2	-66.2	-13.0	-53.2
2	165.80	-52.1	-57.9	-3.0	-60.9	-13.0	-47.9
3	264.74	-57.0	-62.0	-1.6	-63.6	-13.0	-50.6
4	613.94	-65.3	-69.2	3.7	-65.5	-13.0	-52.5
5	743.92	-64.5	-66.4	3.7	-62.7	-13.0	-49.7
6	996.12	-64.8	-61.3	3.3	-58.0	-13.0	-45.0

Remarks:

1. ERP (dBm) = S.G Value (dBm) + Correction Factor (dB).
2. Correction Factor (dB) = Substitution Antenna Gain (dB) + Cable Loss (dB).

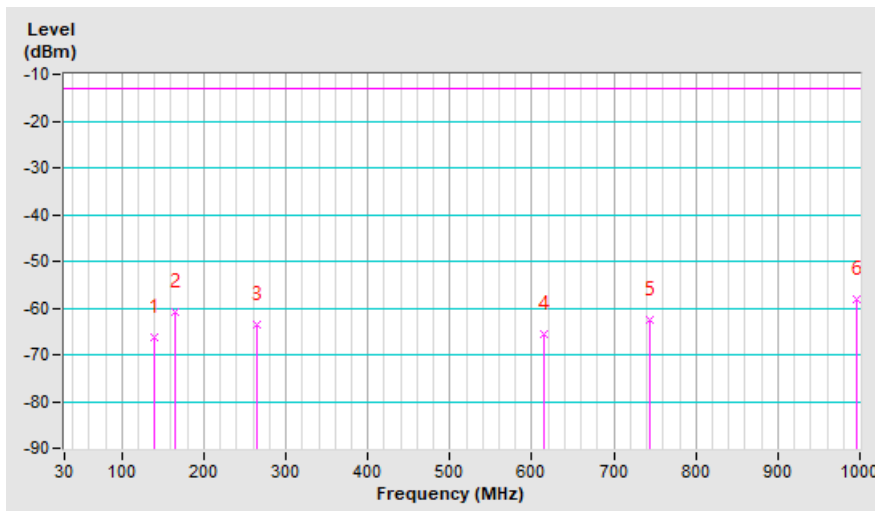

Mode	TX channel 23230+48	Frequency Range	Below 1000 MHz
------	---------------------	-----------------	----------------

Antenna Polarity & Test Distance: Vertical at 3 m							
No.	Freq. (MHz)	Reading (dBm)	S.G Power Value (dBm)	Correction Factor (dB)	ERP (dBm)	Limit (dBm)	Margin (dB)
1	39.70	-52.3	-48.2	-13.7	-61.9	-13.0	-48.9
2	198.78	-51.8	-50.4	-2.4	-52.8	-13.0	-39.8
3	289.96	-59.3	-56.5	-1.7	-58.2	-13.0	-45.2
4	361.74	-64.9	-69.1	3.8	-65.3	-13.0	-52.3
5	635.28	-69.6	-68.5	3.7	-64.8	-13.0	-51.8
6	722.58	-67.0	-64.3	3.6	-60.7	-13.0	-47.7

Remarks:

1. ERP (dBm) = S.G Value (dBm) + Correction Factor (dB).
2. Correction Factor (dB) = Substitution Antenna Gain (dB) + Cable Loss (dB).

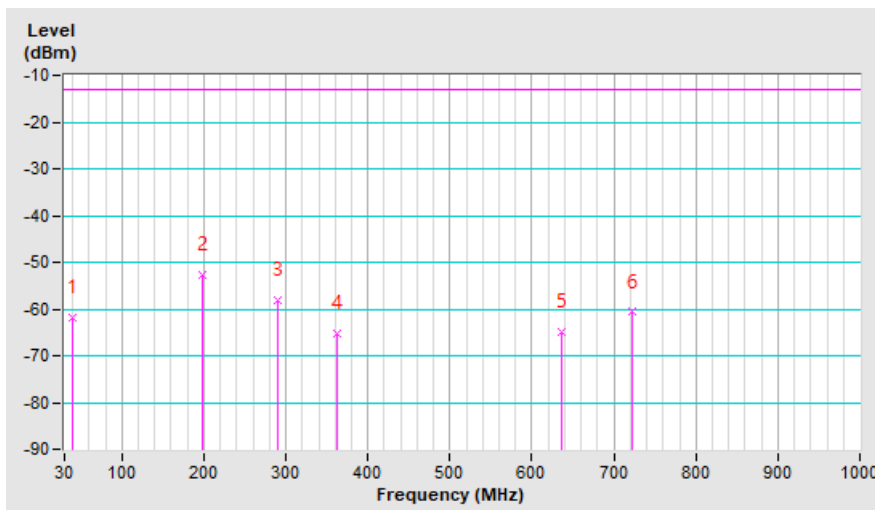

LTE Band 13 (BW: 5MHz) CH23230 + BT LE CH 0

Mode	TX channel 23230+0	Frequency Range	Below 1000 MHz
------	--------------------	-----------------	----------------

Antenna Polarity & Test Distance: Horizontal at 3 m							
No.	Freq. (MHz)	Reading (dBm)	S.G Power Value (dBm)	Correction Factor (dB)	ERP (dBm)	Limit (dBm)	Margin (dB)
1	80.44	-59.7	-67.2	0.5	-66.7	-13.0	-53.7
2	169.68	-47.5	-53.7	-2.8	-56.5	-13.0	-43.5
3	272.50	-55.0	-60.0	-1.5	-61.5	-13.0	-48.5
4	476.20	-64.9	-70.8	3.6	-67.2	-13.0	-54.2
5	660.50	-64.8	-68.2	3.7	-64.5	-13.0	-51.5
6	986.42	-64.2	-61.0	3.5	-57.5	-13.0	-44.5

Remarks:

1. ERP (dBm) = S.G Value (dBm) + Correction Factor (dB).
2. Correction Factor (dB) = Substitution Antenna Gain (dB) + Cable Loss (dB).

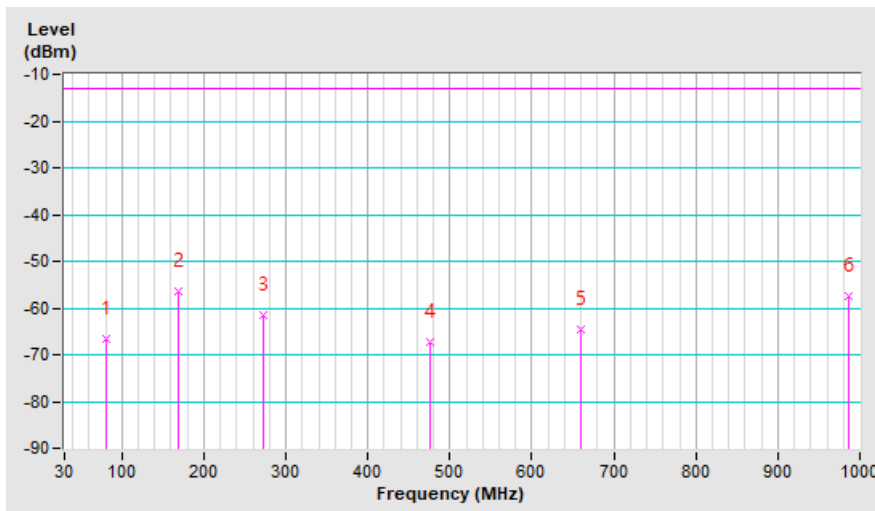

Mode	TX channel 23230+0	Frequency Range	Below 1000 MHz
------	--------------------	-----------------	----------------

Antenna Polarity & Test Distance: Vertical at 3 m							
No.	Freq. (MHz)	Reading (dBm)	S.G Power Value (dBm)	Correction Factor (dB)	ERP (dBm)	Limit (dBm)	Margin (dB)
1	136.70	-63.5	-63.5	-3.2	-66.7	-13.0	-53.7
2	293.84	-61.7	-59.7	-1.8	-61.5	-13.0	-48.5
3	342.34	-65.7	-70.2	3.9	-66.3	-13.0	-53.3
4	497.54	-68.9	-72.7	3.8	-68.9	-13.0	-55.9
5	736.16	-72.2	-69.2	3.7	-65.5	-13.0	-52.5
6	934.04	-73.4	-68.2	3.7	-64.5	-13.0	-51.5

Remarks:

1. ERP (dBm) = S.G Value (dBm) + Correction Factor (dB).
2. Correction Factor (dB) = Substitution Antenna Gain (dB) + Cable Loss (dB).

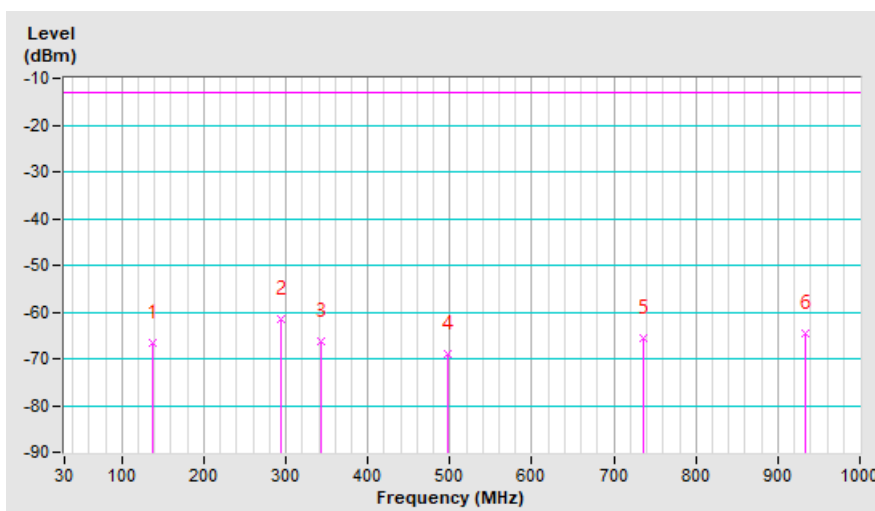

LTE Band 26 (BW: 3MHz) CH 27025 + 802.11g CH 6

Mode	TX channel 27025+6	Frequency Range	Below 1000 MHz
------	--------------------	-----------------	----------------

Antenna Polarity & Test Distance: Horizontal at 3 m							
No.	Freq. (MHz)	Reading (dBm)	S.G Power Value (dBm)	Correction Factor (dB)	ERP (dBm)	Limit (dBm)	Margin (dB)
1	35.82	-54.2	-37.0	-15.9	-52.9	-13.0	-39.9
2	138.64	-55.6	-60.6	-3.2	-63.8	-13.0	-50.8
3	198.78	-48.0	-56.2	-2.4	-58.6	-13.0	-45.6
4	353.98	-62.3	-71.5	3.9	-67.6	-13.0	-54.6
5	600.36	-65.1	-69.6	3.8	-65.8	-13.0	-52.8
6	813.76	-65.1	-65.3	4.0	-61.3	-13.0	-48.3

Remarks:

1. ERP (dBm) = S.G Value (dBm) + Correction Factor (dB).
2. Correction Factor (dB) = Substitution Antenna Gain (dB) + Cable Loss (dB).

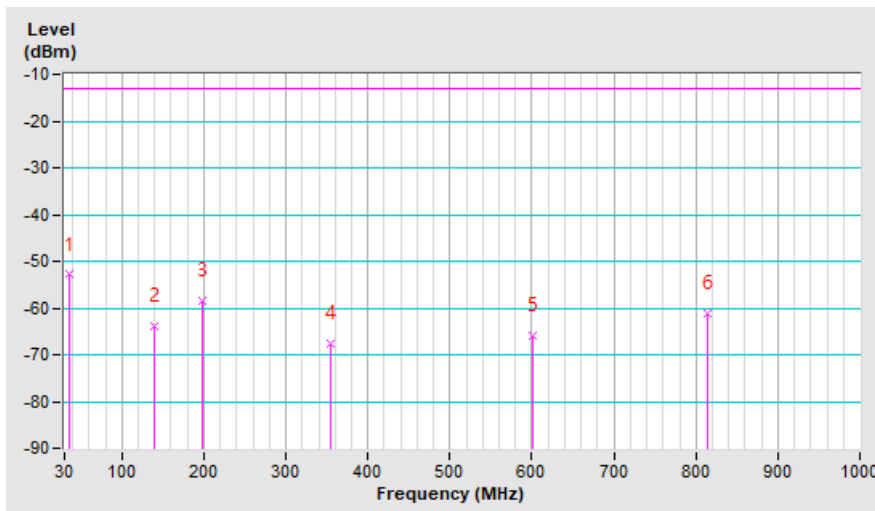

Mode	TX channel 27025+6	Frequency Range	Below 1000 MHz
------	--------------------	-----------------	----------------

Antenna Polarity & Test Distance: Vertical at 3 m							
No.	Freq. (MHz)	Reading (dBm)	S.G Power Value (dBm)	Correction Factor (dB)	ERP (dBm)	Limit (dBm)	Margin (dB)
1	37.76	-43.2	-40.1	-14.7	-54.8	-13.0	-41.8
2	80.44	-54.9	-62.2	0.5	-61.7	-13.0	-48.7
3	177.44	-40.4	-43.3	-3.0	-46.3	-13.0	-33.3
4	383.08	-61.1	-67.3	3.5	-63.8	-13.0	-50.8
5	709.00	-64.6	-64.3	3.5	-60.8	-13.0	-47.8
6	992.24	-64.3	-60.0	3.4	-56.6	-13.0	-43.6

Remarks:

1. ERP (dBm) = S.G Value (dBm) + Correction Factor (dB).
2. Correction Factor (dB) = Substitution Antenna Gain (dB) + Cable Loss (dB).

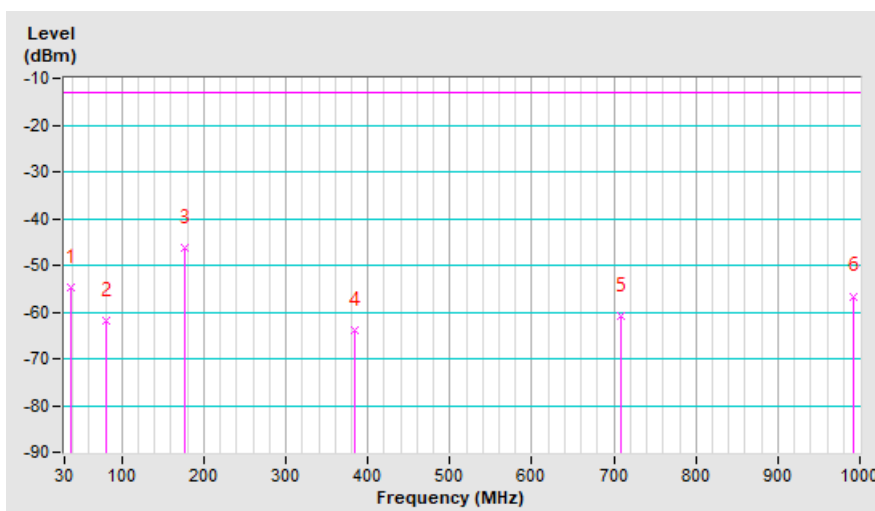

LTE Band 26 (BW: 3MHz) CH 27025 + 802.11n (HT20) CH 48

Mode	TX channel 27025+48	Frequency Range	Below 1000 MHz
------	---------------------	-----------------	----------------

Antenna Polarity & Test Distance: Horizontal at 3 m							
No.	Freq. (MHz)	Reading (dBm)	S.G Power Value (dBm)	Correction Factor (dB)	ERP (dBm)	Limit (dBm)	Margin (dB)
1	31.94	-48.9	-29.3	-18.3	-47.6	-13.0	-34.6
2	169.68	-48.2	-54.3	-2.8	-57.1	-13.0	-44.1
3	216.24	-48.8	-57.3	-2.0	-59.3	-13.0	-46.3
4	299.66	-59.5	-68.5	2.5	-66.0	-13.0	-53.0
5	621.70	-64.8	-68.6	3.7	-64.9	-13.0	-51.9
6	903.00	-65.0	-63.2	3.6	-59.6	-13.0	-46.6

Remarks:

- ERP (dBm) = S.G Value (dBm) + Correction Factor (dB).
- Correction Factor (dB) = Substitution Antenna Gain (dB) + Cable Loss (dB).

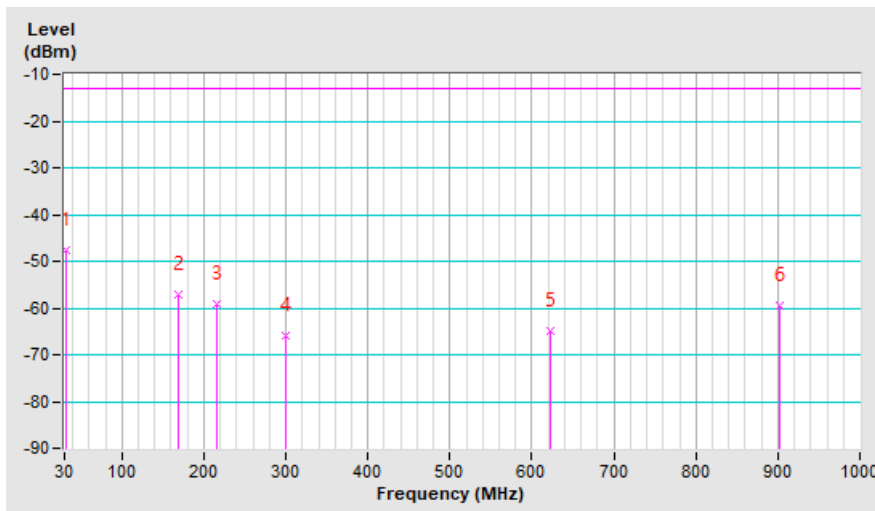

Mode	TX channel 27025+48	Frequency Range	Below 1000 MHz
------	---------------------	-----------------	----------------

Antenna Polarity & Test Distance: Vertical at 3 m							
No.	Freq. (MHz)	Reading (dBm)	S.G Power Value (dBm)	Correction Factor (dB)	ERP (dBm)	Limit (dBm)	Margin (dB)
1	30.00	-41.0	-33.7	-19.4	-53.1	-13.0	-40.1
2	80.44	-54.9	-62.2	0.5	-61.7	-13.0	-48.7
3	194.90	-48.4	-49.0	-2.6	-51.6	-13.0	-38.6
4	412.18	-63.2	-69.0	3.3	-65.7	-13.0	-52.7
5	652.74	-64.8	-64.9	3.6	-61.3	-13.0	-48.3
6	930.16	-64.2	-61.2	3.7	-57.5	-13.0	-44.5

Remarks:

1. ERP (dBm) = S.G Value (dBm) + Correction Factor (dB).
2. Correction Factor (dB) = Substitution Antenna Gain (dB) + Cable Loss (dB).

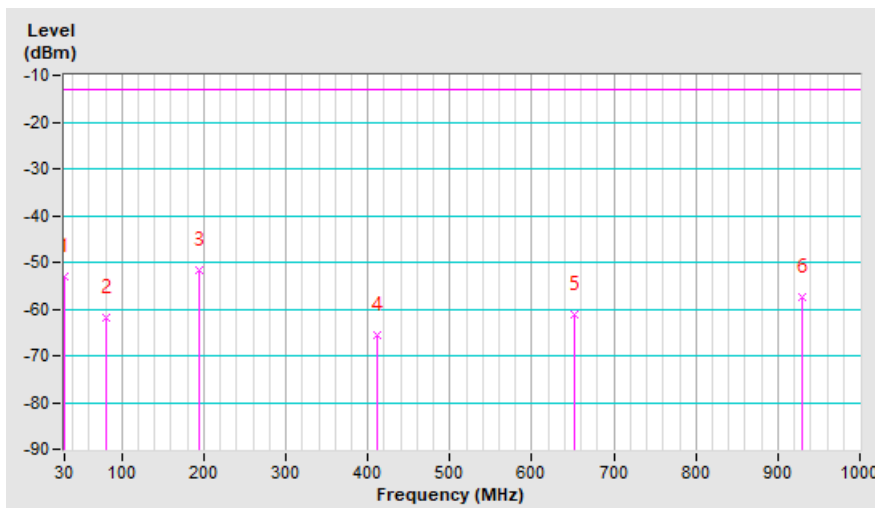

LTE Band 26 (BW: 3MHz) CH 27025 + BT LE CH 0

Mode	TX channel 27025+0	Frequency Range	Below 1000 MHz
------	--------------------	-----------------	----------------

Antenna Polarity & Test Distance: Horizontal at 3 m							
No.	Freq. (MHz)	Reading (dBm)	S.G Power Value (dBm)	Correction Factor (dB)	ERP (dBm)	Limit (dBm)	Margin (dB)
1	30.00	-49.1	-27.9	-19.4	-47.3	-13.0	-34.3
2	90.14	-57.8	-67.7	-0.2	-67.9	-13.0	-54.9
3	189.08	-48.3	-56.1	-2.8	-58.9	-13.0	-45.9
4	247.28	-53.3	-60.8	-1.5	-62.3	-13.0	-49.3
5	383.08	-62.2	-69.0	3.5	-65.5	-13.0	-52.5
6	947.62	-64.2	-61.8	3.8	-58.0	-13.0	-45.0

Remarks:

- ERP (dBm) = S.G Value (dBm) + Correction Factor (dB).
- Correction Factor (dB) = Substitution Antenna Gain (dB) + Cable Loss (dB).

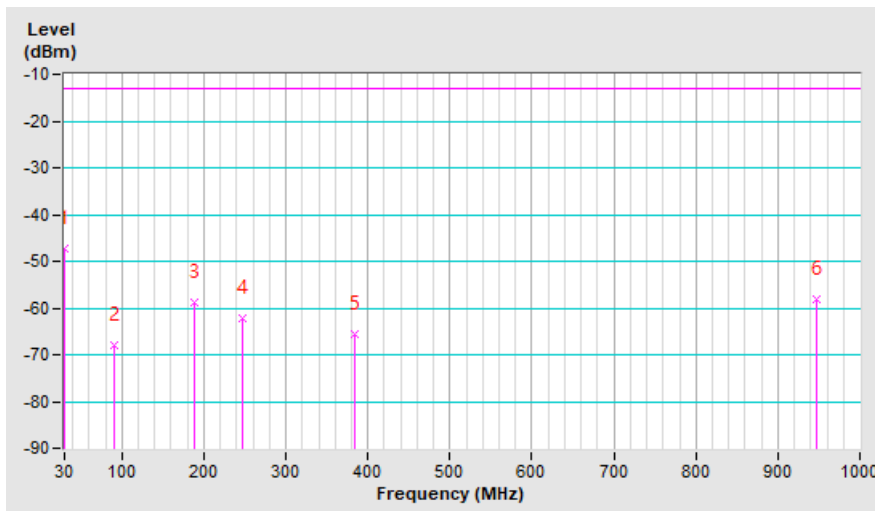

Mode	TX channel 27025+0	Frequency Range	Below 1000 MHz
------	--------------------	-----------------	----------------

Antenna Polarity & Test Distance: Vertical at 3 m							
No.	Freq. (MHz)	Reading (dBm)	S.G Power Value (dBm)	Correction Factor (dB)	ERP (dBm)	Limit (dBm)	Margin (dB)
1	31.94	-43.1	-37.5	-18.3	-55.8	-13.0	-42.8
2	92.08	-52.3	-60.8	-0.6	-61.4	-13.0	-48.4
3	204.60	-51.0	-53.0	-2.0	-55.0	-13.0	-42.0
4	400.54	-62.5	-68.8	3.3	-65.5	-13.0	-52.5
5	662.44	-64.8	-65.2	3.7	-61.5	-13.0	-48.5
6	897.18	-65.2	-62.5	3.5	-59.0	-13.0	-46.0

Remarks:

1. ERP (dBm) = S.G Value (dBm) + Correction Factor (dB).
2. Correction Factor (dB) = Substitution Antenna Gain (dB) + Cable Loss (dB).

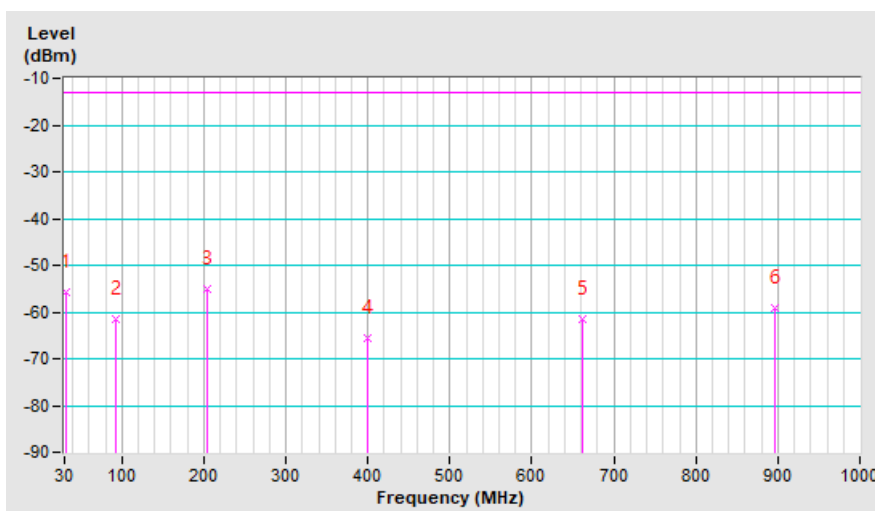

LTE Band 26 (BW: 3MHz) CH 26775 + 802.11g CH 6

Mode	TX channel 26775+6	Frequency Range	Below 1000 MHz
------	--------------------	-----------------	----------------

Antenna Polarity & Test Distance: Horizontal at 3 m							
No.	Freq. (MHz)	Reading (dBm)	S.G Power Value (dBm)	Correction Factor (dB)	ERP (dBm)	Limit (dBm)	Margin (dB)
1	41.64	-64.5	-52.3	-12.3	-64.6	-13.0	-51.6
2	189.08	-47.2	-55.0	-2.8	-57.8	-13.0	-44.8
3	291.90	-56.4	-60.2	-2.1	-62.3	-13.0	-49.3
4	394.72	-65.8	-71.9	3.3	-68.6	-13.0	-55.6
5	565.44	-69.9	-75.0	3.8	-71.2	-13.0	-58.2
6	881.66	-72.3	-70.8	3.3	-67.5	-13.0	-54.5

Remarks:

- ERP (dBm) = S.G Value (dBm) + Correction Factor (dB).
- Correction Factor (dB) = Substitution Antenna Gain (dB) + Cable Loss (dB).

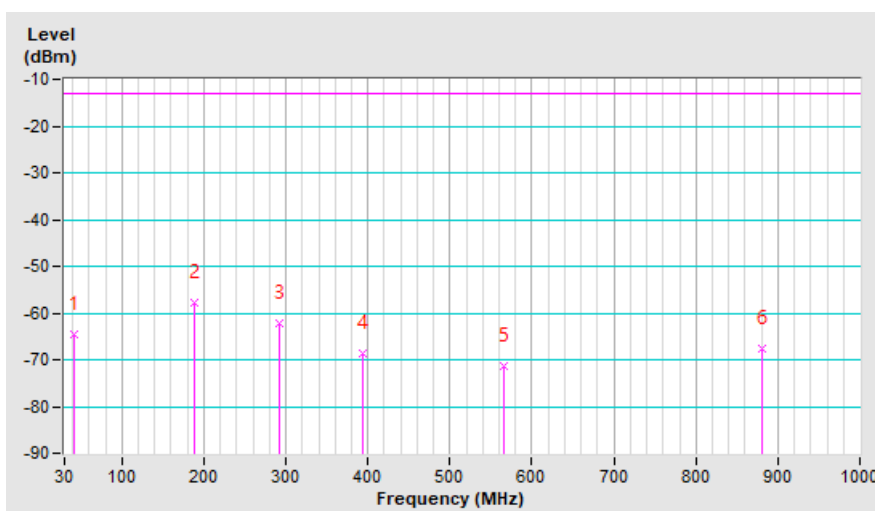

Mode	TX channel 26775+6	Frequency Range	Below 1000 MHz
------	--------------------	-----------------	----------------

Antenna Polarity & Test Distance: Vertical at 3 m							
No.	Freq. (MHz)	Reading (dBm)	S.G Power Value (dBm)	Correction Factor (dB)	ERP (dBm)	Limit (dBm)	Margin (dB)
1	57.16	-53.0	-57.3	-4.7	-62.0	-13.0	-49.0
2	169.68	-46.8	-49.3	-2.8	-52.1	-13.0	-39.1
3	289.96	-65.8	-65.1	-1.7	-66.8	-13.0	-53.8
4	412.18	-67.0	-72.9	3.3	-69.6	-13.0	-56.6
5	544.10	-68.5	-73.1	3.8	-69.3	-13.0	-56.3
6	821.52	-72.5	-71.2	3.9	-67.3	-13.0	-54.3

Remarks:

1. ERP (dBm) = S.G Value (dBm) + Correction Factor (dB).
2. Correction Factor (dB) = Substitution Antenna Gain (dB) + Cable Loss (dB).

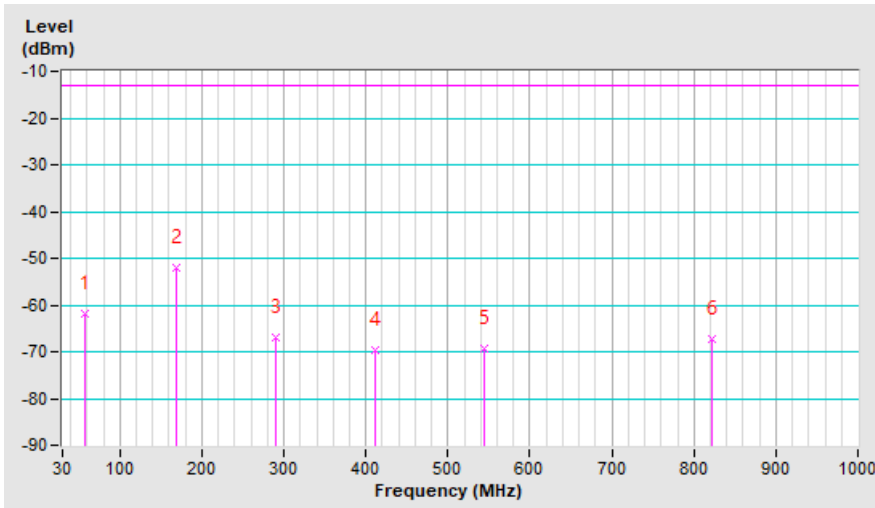

LTE Band 26 (BW: 3MHz) CH 26775 + 802.11n (HT20) CH 48

Mode	TX channel 26775+48	Frequency Range	Below 1000 MHz
------	---------------------	-----------------	----------------

Antenna Polarity & Test Distance: Horizontal at 3 m							
No.	Freq. (MHz)	Reading (dBm)	S.G Power Value (dBm)	Correction Factor (dB)	ERP (dBm)	Limit (dBm)	Margin (dB)
1	37.76	-58.4	-42.6	-14.7	-57.3	-13.0	-44.3
2	169.68	-48.0	-54.2	-2.8	-57.0	-13.0	-44.0
3	239.52	-55.2	-62.7	-1.5	-64.2	-13.0	-51.2
4	357.86	-63.8	-72.8	4.0	-68.8	-13.0	-55.8
5	613.94	-70.1	-74.0	3.7	-70.3	-13.0	-57.3
6	906.88	-72.5	-70.8	3.6	-67.2	-13.0	-54.2

Remarks:

1. ERP (dBm) = S.G Value (dBm) + Correction Factor (dB).
2. Correction Factor (dB) = Substitution Antenna Gain (dB) + Cable Loss (dB).

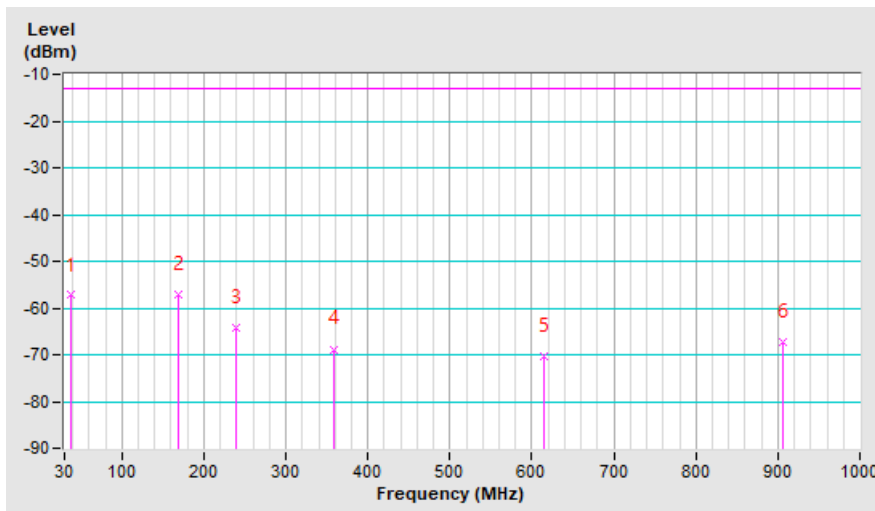

Mode	TX channel 26775+48	Frequency Range	Below 1000 MHz
------	---------------------	-----------------	----------------

Antenna Polarity & Test Distance: Vertical at 3 m

No.	Freq. (MHz)	Reading (dBm)	S.G Power Value (dBm)	Correction Factor (dB)	ERP (dBm)	Limit (dBm)	Margin (dB)
1	95.96	-57.4	-66.4	-1.2	-67.6	-13.0	-54.6
2	204.60	-52.0	-54.0	-2.0	-56.0	-13.0	-43.0
3	249.22	-58.9	-59.8	-1.4	-61.2	-13.0	-48.2
4	352.04	-64.7	-71.1	3.9	-67.2	-13.0	-54.2
5	606.18	-71.5	-73.1	3.7	-69.4	-13.0	-56.4
6	765.26	-71.8	-70.8	3.8	-67.0	-13.0	-54.0

Remarks:

1. ERP (dBm) = S.G Value (dBm) + Correction Factor (dB).
2. Correction Factor (dB) = Substitution Antenna Gain (dB) + Cable Loss (dB).

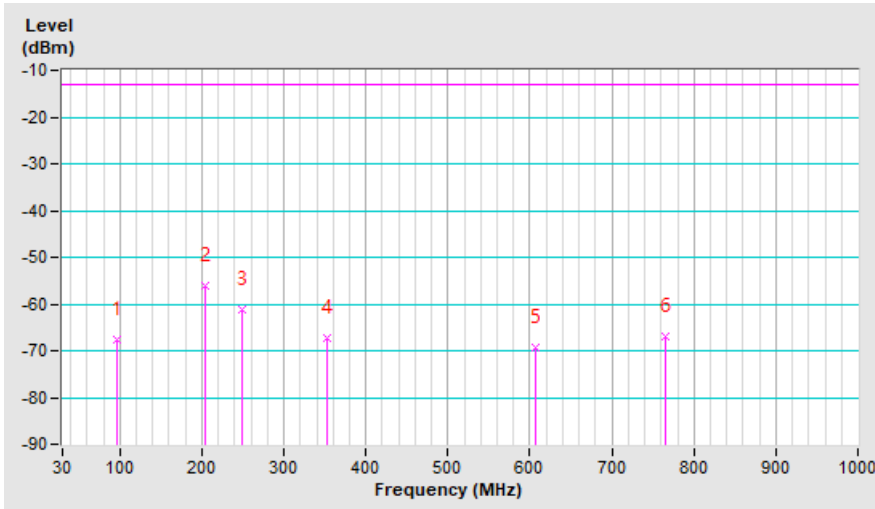

LTE Band 26 (BW: 3MHz) CH 26775 + BT LE CH 0

Mode	TX channel 26775+0	Frequency Range	Below 1000 MHz
------	--------------------	-----------------	----------------

Antenna Polarity & Test Distance: Horizontal at 3 m							
No.	Freq. (MHz)	Reading (dBm)	S.G Power Value (dBm)	Correction Factor (dB)	ERP (dBm)	Limit (dBm)	Margin (dB)
1	59.10	-59.6	-62.4	-3.8	-66.2	-13.0	-53.2
2	152.22	-60.9	-64.5	-2.8	-67.3	-13.0	-54.3
3	255.04	-57.2	-63.3	-1.4	-64.7	-13.0	-51.7
4	352.04	-64.2	-73.4	3.9	-69.5	-13.0	-56.5
5	635.28	-71.0	-74.7	3.7	-71.0	-13.0	-58.0
6	924.34	-73.3	-70.9	3.6	-67.3	-13.0	-54.3

Remarks:

- ERP (dBm) = S.G Value (dBm) + Correction Factor (dB).
- Correction Factor (dB) = Substitution Antenna Gain (dB) + Cable Loss (dB).

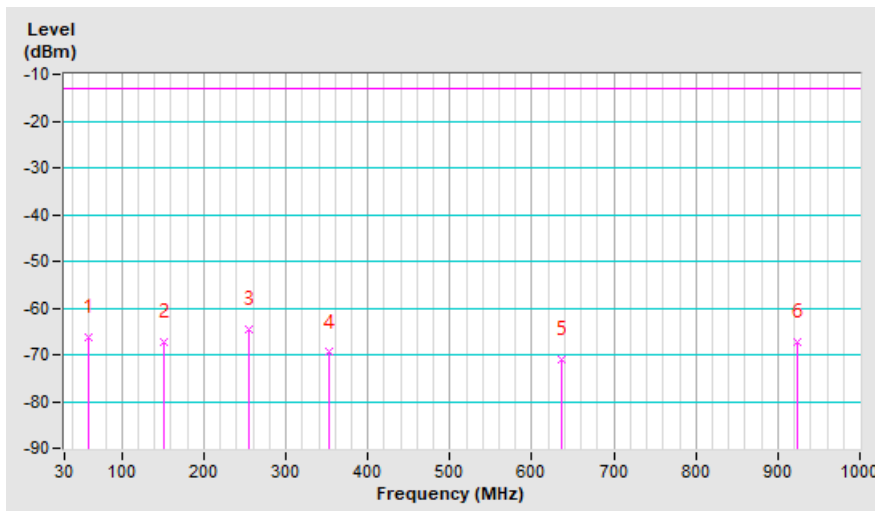

Mode	TX channel 26775+0	Frequency Range	Below 1000 MHz
------	--------------------	-----------------	----------------

Antenna Polarity & Test Distance: Vertical at 3 m							
No.	Freq. (MHz)	Reading (dBm)	S.G Power Value (dBm)	Correction Factor (dB)	ERP (dBm)	Limit (dBm)	Margin (dB)
1	35.82	-44.6	-40.6	-15.9	-56.5	-13.0	-43.5
2	181.32	-42.0	-44.5	-3.0	-47.5	-13.0	-34.5
3	363.68	-62.3	-68.7	3.9	-64.8	-13.0	-51.8
4	633.34	-70.7	-71.5	3.6	-67.9	-13.0	-54.9
5	840.92	-70.4	-68.9	3.7	-65.2	-13.0	-52.2
6	998.06	-73.6	-69.1	3.3	-65.8	-13.0	-52.8

Remarks:

1. ERP (dBm) = S.G Value (dBm) + Correction Factor (dB).
2. Correction Factor (dB) = Substitution Antenna Gain (dB) + Cable Loss (dB).

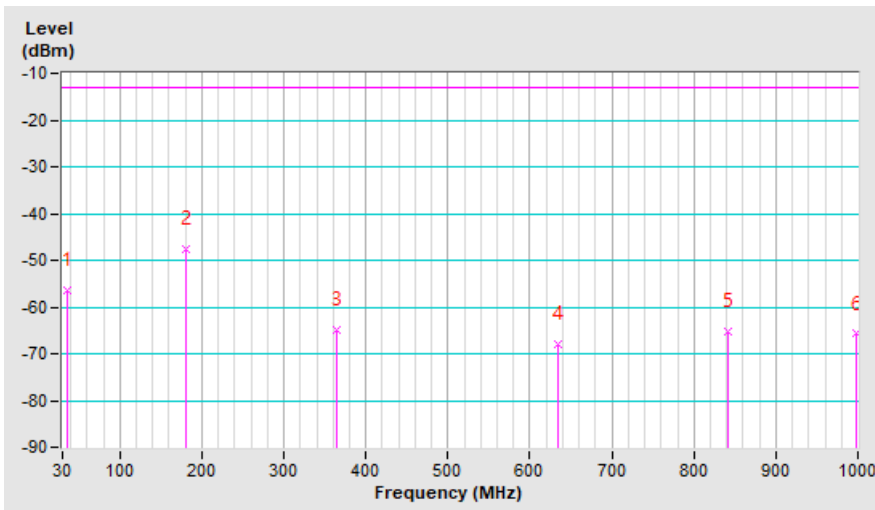

Above 1GHz Data:

LTE Band 2 (BW: 3MHz) CH18615 + 802.11g CH 6
 LTE Band 2 (BW: 3MHz)

CHANNEL		18615					
Antenna Polarity & Test Distance: Horizontal at 3 m (For FCC Part 24)							
No.	Freq. (MHz)	Reading (dBm)	S.G Power Value (dBm)	Correction Factor (dB)	EIRP (dBm)	Limit (dBm)	Margin (dB)
1	3703.00	-56.2	-47.7	1.4	-46.3	-13.0	-33.3
Antenna Polarity & Test Distance: Vertical at 3 m (For FCC Part 24)							
No.	Freq. (MHz)	Reading (dBm)	S.G Power Value (dBm)	Correction Factor (dB)	EIRP (dBm)	Limit (dBm)	Margin (dB)
1	3703.00	-60.8	-52.6	1.4	-51.2	-13.0	-38.2

Remarks:

1. EIRP (dBm) = S.G Value (dBm) + Correction Factor (dB).
2. Correction Factor (dB) = Substitution Antenna Gain (dB) + Cable Loss (dB).

802.11g

CHANNEL	6	DETECTOR FUNCTION	Peak (PK) Average (AV)
FREQUENCY RANGE	1GHz ~ 25GHz		

ANTENNA POLARITY & TEST DISTANCE: HORIZONTAL AT 3 m (For FCC 15.247)								
NO.	FREQ. (MHz)	EMISSION LEVEL (dBuV/m)	LIMIT (dBuV/m)	MARGIN (dB)	ANTENNA HEIGHT (m)	TABLE ANGLE (Degree)	RAW VALUE (dBuV)	CORRECTION FACTOR (dB/m)
1	*2437.00	113.7 PK			2.08 H	210	81.9	31.8
2	*2437.00	103.3 AV			2.08 H	210	71.5	31.8
3	4874.00	46.2 PK	74.0	-27.8	1.40 H	180	42.7	3.5
4	4874.00	33.5 AV	54.0	-20.5	1.40 H	180	30.0	3.5
ANTENNA POLARITY & TEST DISTANCE: VERTICAL AT 3 m (For FCC 15.247)								
NO.	FREQ. (MHz)	EMISSION LEVEL (dBuV/m)	LIMIT (dBuV/m)	MARGIN (dB)	ANTENNA HEIGHT (m)	TABLE ANGLE (Degree)	RAW VALUE (dBuV)	CORRECTION FACTOR (dB/m)
1	*2437.00	112.7 PK			1.29 V	151	80.9	31.8
2	*2437.00	102.6 AV			1.29 V	151	70.8	31.8
3	4874.00	38.4 PK	74.0	-35.6	2.80 V	219	34.9	3.5
4	4874.00	26.4 AV	54.0	-27.6	2.80 V	219	22.9	3.5

Remarks:

1. Emission Level(dBuV/m) = Raw Value(dBuV) + Correction Factor(dB/m)
2. Correction Factor(dB/m) = Antenna Factor(dB/m) + Cable Factor(dB)
3. The other emission levels were very low against the limit.
4. Margin value = Emission Level – Limit value
5. " * ": Fundamental frequency.

LTE Band 2 (BW: 3MHz) CH18615 + 802.11n (HT20) CH 48
 LTE Band 2 (BW: 3MHz)

CHANNEL		18615					
Antenna Polarity & Test Distance: Horizontal at 3 m (For FCC Part 24)							
No.	Freq. (MHz)	Reading (dBm)	S.G Power Value (dBm)	Correction Factor (dB)	EIRP (dBm)	Limit (dBm)	Margin (dB)
1	3703.00	-56.0	-47.5	1.4	-46.1	-13.0	-33.1
Antenna Polarity & Test Distance: Vertical at 3 m (For FCC Part 24)							
No.	Freq. (MHz)	Reading (dBm)	S.G Power Value (dBm)	Correction Factor (dB)	EIRP (dBm)	Limit (dBm)	Margin (dB)
1	3703.00	-60.5	-52.3	1.4	-50.9	-13.0	-37.9

Remarks:

1. EIRP (dBm) = S.G Value (dBm) + Correction Factor (dB).
2. Correction Factor (dB) = Substitution Antenna Gain (dB) + Cable Loss (dB).

802.11n (HT20)

CHANNEL	48	DETECTOR FUNCTION	Peak (PK) Average (AV)
FREQUENCY RANGE	1GHz ~ 25GHz		

ANTENNA POLARITY & TEST DISTANCE: HORIZONTAL AT 3 m (For FCC 15.247)								
NO.	FREQ. (MHz)	EMISSION LEVEL (dBuV/m)	LIMIT (dBuV/m)	MARGIN (dB)	ANTENNA HEIGHT (m)	TABLE ANGLE (Degree)	RAW VALUE (dBuV)	CORRECTION FACTOR (dB/m)
1	*5240.00	111.5 PK			1.56 H	186	73.8	37.7
2	*5240.00	100.4 AV			1.56 H	186	62.7	37.7
3	5350.00	54.1 PK	74.0	-19.9	1.43 H	175	50.7	3.4
4	5350.00	43.8 AV	54.0	-10.2	1.43 H	175	40.4	3.4
5	#10480.00	55.8 PK	68.2	-12.4	1.29 H	229	40.4	15.4
ANTENNA POLARITY & TEST DISTANCE: VERTICAL AT 3 m (For FCC 15.247)								
NO.	FREQ. (MHz)	EMISSION LEVEL (dBuV/m)	LIMIT (dBuV/m)	MARGIN (dB)	ANTENNA HEIGHT (m)	TABLE ANGLE (Degree)	RAW VALUE (dBuV)	CORRECTION FACTOR (dB/m)
1	*5240.00	112.6 PK			1.11 V	151	74.9	37.7
2	*5240.00	101.6 AV			1.11 V	151	63.9	37.7
3	5350.00	55.3 PK	74.0	-18.7	1.19 V	159	51.9	3.4
4	5350.00	43.9 AV	54.0	-10.1	1.19 V	159	40.5	3.4
5	#10480.00	57.2 PK	68.2	-11.0	2.59 V	103	41.8	15.4

Remarks:

1. Emission Level(dBuV/m) = Raw Value(dBuV) + Correction Factor(dB/m)
2. Correction Factor(dB/m) = Antenna Factor(dB/m) + Cable Factor(dB)
3. The other emission levels were very low against the limit.
4. Margin value = Emission Level – Limit value
5. " * ": Fundamental frequency.
6. " # ": The radiated frequency is out of the restricted band.

LTE Band 2 (BW: 3MHz) CH18615 + BT LE CH 0

LTE Band 2 (BW: 3MHz)

CHANNEL		18615					
Antenna Polarity & Test Distance: Horizontal at 3 m (For FCC Part 24)							
No.	Freq. (MHz)	Reading (dBm)	S.G Power Value (dBm)	Correction Factor (dB)	EIRP (dBm)	Limit (dBm)	Margin (dB)
1	3703.00	-56.0	-47.5	1.4	-46.1	-13.0	-33.1
Antenna Polarity & Test Distance: Vertical at 3 m (For FCC Part 24)							
No.	Freq. (MHz)	Reading (dBm)	S.G Power Value (dBm)	Correction Factor (dB)	EIRP (dBm)	Limit (dBm)	Margin (dB)
1	3703.00	-60.3	-52.1	1.4	-50.7	-13.0	-37.7

Remarks:

1. EIRP (dBm) = S.G Value (dBm) + Correction Factor (dB).
2. Correction Factor (dB) = Substitution Antenna Gain (dB) + Cable Loss (dB).

BT LE

CHANNEL	0	DETECTOR FUNCTION	Peak (PK) Average (AV)
FREQUENCY RANGE	1GHz ~ 25GHz		

ANTENNA POLARITY & TEST DISTANCE: HORIZONTAL AT 3 m (For FCC 15.247)								
NO.	FREQ. (MHz)	EMISSION LEVEL (dBuV/m)	LIMIT (dBuV/m)	MARGIN (dB)	ANTENNA HEIGHT (m)	TABLE ANGLE (Degree)	RAW VALUE (dBuV)	CORRECTION FACTOR (dB/m)
1	2390.00	57.8 PK	74.0	-16.2	2.32 H	254	26.0	31.8
2	2390.00	45.6 AV	54.0	-8.4	2.32 H	254	13.8	31.8
3	*2402.00	98.3 PK			2.29 H	253	66.5	31.8
4	*2402.00	93.7 AV			2.29 H	253	61.9	31.8
5	4804.00	46.2 PK	74.0	-27.8	2.84 H	148	42.5	3.7
6	4804.00	32.9 AV	54.0	-21.1	2.84 H	148	29.2	3.7
ANTENNA POLARITY & TEST DISTANCE: VERTICAL AT 3 m (For FCC 15.247)								
NO.	FREQ. (MHz)	EMISSION LEVEL (dBuV/m)	LIMIT (dBuV/m)	MARGIN (dB)	ANTENNA HEIGHT (m)	TABLE ANGLE (Degree)	RAW VALUE (dBuV)	CORRECTION FACTOR (dB/m)
1	2390.00	57.8 PK	74.0	-16.2	1.20 V	230	26.0	31.8
2	2390.00	45.8 AV	54.0	-8.2	1.20 V	230	14.0	31.8
3	*2402.00	93.6 PK			1.28 V	210	61.8	31.8
4	*2402.00	88.6 AV			1.28 V	210	56.8	31.8
5	4804.00	45.2 PK	74.0	-28.8	1.59 V	249	41.5	3.7
6	4804.00	32.4 AV	54.0	-21.6	1.59 V	249	28.7	3.7

Remarks:

1. Emission Level(dBuV/m) = Raw Value(dBuV) + Correction Factor(dB/m)
2. Correction Factor(dB/m) = Antenna Factor(dB/m) + Cable Factor(dB)
3. The other emission levels were very low against the limit.
4. Margin value = Emission Level – Limit value
5. " * ": Fundamental frequency.

LTE Band 13 (BW: 5MHz) CH23230 + 802.11g CH 6
 LTE Band 13 (BW: 5MHz)

CHANNEL		23230					
Antenna Polarity & Test Distance: Horizontal at 3 m (For FCC Part 27)							
No.	Freq. (MHz)	Reading (dBm)	S.G Power Value (dBm)	Correction Factor (dB)	ERP (dBm)	Limit (dBm)	Margin (dB)
1	1564.00	-56.2	-48.4	1.2	-47.2	-40.0	-7.2
Antenna Polarity & Test Distance: Vertical at 3 m (For FCC Part 27)							
No.	Freq. (MHz)	Reading (dBm)	S.G Power Value (dBm)	Correction Factor (dB)	ERP (dBm)	Limit (dBm)	Margin (dB)
1	1564.00	-60.2	-53.3	1.2	-52.1	-40.0	-12.1

Remarks:

1. ERP (dBm) = S.G Value (dBm) + Correction Factor (dB).
2. Correction Factor (dB) = Substitution Antenna Gain (dB) + Cable Loss (dB).

802.11g

CHANNEL	6	DETECTOR FUNCTION	Peak (PK) Average (AV)
FREQUENCY RANGE	1GHz ~ 25GHz		

ANTENNA POLARITY & TEST DISTANCE: HORIZONTAL AT 3 m (For FCC 15.247)								
NO.	FREQ. (MHz)	EMISSION LEVEL (dBuV/m)	LIMIT (dBuV/m)	MARGIN (dB)	ANTENNA HEIGHT (m)	TABLE ANGLE (Degree)	RAW VALUE (dBuV)	CORRECTION FACTOR (dB/m)
1	*2437.00	113.8 PK			2.22 H	255	82.0	31.8
2	*2437.00	103.6 AV			2.22 H	255	71.8	31.8
3	4874.00	46.4 PK	74.0	-27.6	1.44 H	189	42.9	3.5
4	4874.00	33.6 AV	54.0	-20.4	1.44 H	189	30.1	3.5
ANTENNA POLARITY & TEST DISTANCE: VERTICAL AT 3 m (For FCC 15.247)								
NO.	FREQ. (MHz)	EMISSION LEVEL (dBuV/m)	LIMIT (dBuV/m)	MARGIN (dB)	ANTENNA HEIGHT (m)	TABLE ANGLE (Degree)	RAW VALUE (dBuV)	CORRECTION FACTOR (dB/m)
1	*2437.00	112.1 PK			1.15 V	141	80.3	31.8
2	*2437.00	101.9 AV			1.15 V	141	70.1	31.8
3	4874.00	38.0 PK	74.0	-36.0	3.00 V	198	34.5	3.5
4	4874.00	26.0 AV	54.0	-28.0	3.00 V	198	22.5	3.5

Remarks:

1. Emission Level(dBuV/m) = Raw Value(dBuV) + Correction Factor(dB/m)
2. Correction Factor(dB/m) = Antenna Factor(dB/m) + Cable Factor(dB)
3. The other emission levels were very low against the limit.
4. Margin value = Emission Level – Limit value
5. " * ": Fundamental frequency.

LTE Band 13 (BW: 5MHz) CH23230 + 802.11n (HT20) CH 48
 LTE Band 13 (BW: 5MHz)

CHANNEL		23230					
Antenna Polarity & Test Distance: Horizontal at 3 m (For FCC Part 27)							
No.	Freq. (MHz)	Reading (dBm)	S.G Power Value (dBm)	Correction Factor (dB)	ERP (dBm)	Limit (dBm)	Margin (dB)
1	1564.00	-56.8	-48.9	1.2	-47.7	-40.0	-7.7
Antenna Polarity & Test Distance: Vertical at 3 m (For FCC Part 27)							
No.	Freq. (MHz)	Reading (dBm)	S.G Power Value (dBm)	Correction Factor (dB)	ERP (dBm)	Limit (dBm)	Margin (dB)
1	1564.00	-60.0	-53.1	1.2	-51.9	-40.0	-11.9

Remarks:

1. ERP (dBm) = S.G Value (dBm) + Correction Factor (dB).
2. Correction Factor (dB) = Substitution Antenna Gain (dB) + Cable Loss (dB).

802.11n (HT20)

CHANNEL	48	DETECTOR FUNCTION	Peak (PK) Average (AV)
FREQUENCY RANGE	1GHz ~ 25GHz		

ANTENNA POLARITY & TEST DISTANCE: HORIZONTAL AT 3 m (For FCC 15.247)								
NO.	FREQ. (MHz)	EMISSION LEVEL (dBuV/m)	LIMIT (dBuV/m)	MARGIN (dB)	ANTENNA HEIGHT (m)	TABLE ANGLE (Degree)	RAW VALUE (dBuV)	CORRECTION FACTOR (dB/m)
1	*5240.00	111.3 PK			1.50 H	180	73.6	37.7
2	*5240.00	100.2 AV			1.50 H	180	62.5	37.7
3	5350.00	54.1 PK	74.0	-19.9	1.43 H	170	50.7	3.4
4	5350.00	43.5 AV	54.0	-10.5	1.43 H	170	40.1	3.4
5	#10480.00	55.7 PK	68.2	-12.5	1.21 H	223	40.3	15.4
ANTENNA POLARITY & TEST DISTANCE: VERTICAL AT 3 m (For FCC 15.247)								
NO.	FREQ. (MHz)	EMISSION LEVEL (dBuV/m)	LIMIT (dBuV/m)	MARGIN (dB)	ANTENNA HEIGHT (m)	TABLE ANGLE (Degree)	RAW VALUE (dBuV)	CORRECTION FACTOR (dB/m)
1	*5240.00	112.7 PK			1.15 V	161	75.0	37.7
2	*5240.00	101.7 AV			1.15 V	160	64.0	37.7
3	5350.00	55.4 PK	74.0	-18.6	1.21 V	158	52.0	3.4
4	5350.00	44.1 AV	54.0	-9.9	1.21 V	158	40.7	3.4
5	#10480.00	57.4 PK	68.2	-10.8	2.58 V	108	42.0	15.4

Remarks:

1. Emission Level(dBuV/m) = Raw Value(dBuV) + Correction Factor(dB/m)
2. Correction Factor(dB/m) = Antenna Factor(dB/m) + Cable Factor(dB)
3. The other emission levels were very low against the limit.
4. Margin value = Emission Level – Limit value
5. " * ": Fundamental frequency.
6. " # ": The radiated frequency is out of the restricted band.

LTE Band 13 (BW: 5MHz) CH23230 + BT LE CH 0
 LTE Band 13 (BW: 5MHz)

CHANNEL		23230					
Antenna Polarity & Test Distance: Horizontal at 3 m (For FCC Part 22)							
No.	Freq. (MHz)	Reading (dBm)	S.G Power Value (dBm)	Correction Factor (dB)	ERP (dBm)	Limit (dBm)	Margin (dB)
1	1564.00	-56.4	-48.6	1.2	-47.4	-40.0	-7.4
Antenna Polarity & Test Distance: Vertical at 3 m (For FCC Part 22)							
No.	Freq. (MHz)	Reading (dBm)	S.G Power Value (dBm)	Correction Factor (dB)	ERP (dBm)	Limit (dBm)	Margin (dB)
1	1564.00	-60.5	-53.6	1.2	-52.4	-40.0	-12.4

Remarks:

1. ERP (dBm) = S.G Value (dBm) + Correction Factor (dB).
2. Correction Factor (dB) = Substitution Antenna Gain (dB) + Cable Loss (dB).

BT LE

CHANNEL	0	DETECTOR FUNCTION	Peak (PK) Average (AV)
FREQUENCY RANGE	1GHz ~ 25GHz		

ANTENNA POLARITY & TEST DISTANCE: HORIZONTAL AT 3 m (For FCC 15.247)								
NO.	FREQ. (MHz)	EMISSION LEVEL (dBuV/m)	LIMIT (dBuV/m)	MARGIN (dB)	ANTENNA HEIGHT (m)	TABLE ANGLE (Degree)	RAW VALUE (dBuV)	CORRECTION FACTOR (dB/m)
1	2390.00	57.9 PK	74.0	-16.1	2.33 H	255	26.1	31.8
2	2390.00	45.7 AV	54.0	-8.3	2.33 H	255	13.9	31.8
3	*2402.00	98.5 PK			2.30 H	255	66.7	31.8
4	*2402.00	93.8 AV			2.30 H	255	62.0	31.8
5	4804.00	46.4 PK	74.0	-27.6	2.85 H	151	42.7	3.7
6	4804.00	33.1 AV	54.0	-20.9	2.85 H	151	29.4	3.7
ANTENNA POLARITY & TEST DISTANCE: VERTICAL AT 3 m (For FCC 15.247)								
NO.	FREQ. (MHz)	EMISSION LEVEL (dBuV/m)	LIMIT (dBuV/m)	MARGIN (dB)	ANTENNA HEIGHT (m)	TABLE ANGLE (Degree)	RAW VALUE (dBuV)	CORRECTION FACTOR (dB/m)
1	2390.00	57.7 PK	74.0	-16.3	1.19 V	229	25.9	31.8
2	2390.00	45.7 AV	54.0	-8.3	1.19 V	229	13.9	31.8
3	*2402.00	93.3 PK			1.22 V	220	61.5	31.8
4	*2402.00	88.3 AV			1.22 V	220	56.5	31.8
5	4804.00	45.5 PK	74.0	-28.5	1.58 V	248	41.8	3.7
6	4804.00	32.7 AV	54.0	-21.3	1.58 V	248	29.0	3.7

Remarks:

1. Emission Level(dBuV/m) = Raw Value(dBuV) + Correction Factor(dB/m)
2. Correction Factor(dB/m) = Antenna Factor(dB/m) + Cable Factor(dB)
3. The other emission levels were very low against the limit.
4. Margin value = Emission Level – Limit value
5. " * ": Fundamental frequency.

LTE Band 26 (BW: 3MHz) CH 27025 + 802.11g CH 6
 LTE Band 26 (BW: 3MHz)

CHANNEL		27025					
Antenna Polarity & Test Distance: Horizontal at 3 m(For FCC Part 22)							
No.	Freq. (MHz)	Reading (dBm)	S.G Power Value (dBm)	Correction Factor (dB)	ERP (dBm)	Limit (dBm)	Margin (dB)
1	1695.00	-53.5	-45.9	0.7	-45.2	-13.0	-32.2
Antenna Polarity & Test Distance: Vertical at 3 m(For FCC Part 22)							
No.	Freq. (MHz)	Reading (dBm)	S.G Power Value (dBm)	Correction Factor (dB)	ERP (dBm)	Limit (dBm)	Margin (dB)
1	1695.00	-56.2	-48.9	0.7	-48.2	-13.0	-35.2

Remarks:

1. ERP (dBm) = S.G Value (dBm) + Correction Factor (dB).
2. Correction Factor (dB) = Substitution Antenna Gain (dB) + Cable Loss (dB).

802.11g

CHANNEL		6	DETECTOR FUNCTION	Peak (PK) Average (AV)
FREQUENCY RANGE		1GHz ~ 25GHz		

ANTENNA POLARITY & TEST DISTANCE: HORIZONTAL AT 3 m (For FCC 15.247)								
NO.	FREQ. (MHz)	EMISSION LEVEL (dBuV/m)	LIMIT (dBuV/m)	MARGIN (dB)	ANTENNA HEIGHT (m)	TABLE ANGLE (Degree)	RAW VALUE (dBuV)	CORRECTION FACTOR (dB/m)
1	*2437.00	113.4 PK			2.20 H	220	81.6	31.8
2	*2437.00	102.7 AV			2.20 H	220	70.9	31.8
3	4874.00	45.6 PK	74.0	-28.4	1.33 H	179	42.1	3.5
4	4874.00	32.9 AV	54.0	-21.1	1.33 H	179	29.4	3.5
ANTENNA POLARITY & TEST DISTANCE: VERTICAL AT 3 m (For FCC 15.247)								
NO.	FREQ. (MHz)	EMISSION LEVEL (dBuV/m)	LIMIT (dBuV/m)	MARGIN (dB)	ANTENNA HEIGHT (m)	TABLE ANGLE (Degree)	RAW VALUE (dBuV)	CORRECTION FACTOR (dB/m)
1	*2437.00	112.8 PK			1.31 V	162	81.0	31.8
2	*2437.00	102.8 AV			1.31 V	162	71.0	31.8
3	4874.00	38.6 PK	74.0	-35.4	2.84 V	222	35.1	3.5
4	4874.00	26.8 AV	54.0	-27.2	2.84 V	222	23.3	3.5

Remarks:

1. Emission Level(dBuV/m) = Raw Value(dBuV) + Correction Factor(dB/m)
2. Correction Factor(dB/m) = Antenna Factor(dB/m) + Cable Factor(dB)
3. The other emission levels were very low against the limit.
4. Margin value = Emission Level – Limit value
5. " * ": Fundamental frequency.

LTE Band 26 (BW: 3MHz) CH 27025 + 802.11n (HT20) CH 48
 LTE Band 26 (BW: 3MHz)

CHANNEL		27025					
Antenna Polarity & Test Distance: Horizontal at 3 m (For FCC Part 22)							
No.	Freq. (MHz)	Reading (dBm)	S.G Power Value (dBm)	Correction Factor (dB)	ERP (dBm)	Limit (dBm)	Margin (dB)
1	1695.00	-53.0	-45.5	0.7	-44.8	-13.0	-31.8
Antenna Polarity & Test Distance: Vertical at 3 m (For FCC Part 22)							
No.	Freq. (MHz)	Reading (dBm)	S.G Power Value (dBm)	Correction Factor (dB)	ERP (dBm)	Limit (dBm)	Margin (dB)
1	1695.00	-56.6	-49.3	0.7	-48.6	-13.0	-35.6

Remarks:

1. ERP (dBm) = S.G Value (dBm) + Correction Factor (dB).
2. Correction Factor (dB) = Substitution Antenna Gain (dB) + Cable Loss (dB).

802.11n (HT20)

CHANNEL	48	DETECTOR FUNCTION	Peak (PK) Average (AV)
FREQUENCY RANGE	1GHz ~ 25GHz		

ANTENNA POLARITY & TEST DISTANCE: HORIZONTAL AT 3 m (For FCC 15.247)								
NO.	FREQ. (MHz)	EMISSION LEVEL (dBuV/m)	LIMIT (dBuV/m)	MARGIN (dB)	ANTENNA HEIGHT (m)	TABLE ANGLE (Degree)	RAW VALUE (dBuV)	CORRECTION FACTOR (dB/m)
1	*5240.00	111.6 PK			1.59 H	189	73.9	37.7
2	*5240.00	100.4 AV			1.59 H	189	62.7	37.7
3	5350.00	54.0 PK	74.0	-20.0	1.46 H	178	50.6	3.4
4	5350.00	43.9 AV	54.0	-10.1	1.46 H	176	40.5	3.4
5	#10480.00	55.9 PK	68.2	-12.3	1.30 H	230	40.5	15.4
ANTENNA POLARITY & TEST DISTANCE: VERTICAL AT 3 m (For FCC 15.247)								
NO.	FREQ. (MHz)	EMISSION LEVEL (dBuV/m)	LIMIT (dBuV/m)	MARGIN (dB)	ANTENNA HEIGHT (m)	TABLE ANGLE (Degree)	RAW VALUE (dBuV)	CORRECTION FACTOR (dB/m)
1	*5240.00	112.5 PK			1.09 V	140	74.8	37.7
2	*5240.00	101.5 AV			1.09 V	140	63.8	37.7
3	5350.00	55.1 PK	74.0	-18.9	1.12 V	155	51.7	3.4
4	5350.00	43.8 AV	54.0	-10.2	1.12 V	155	40.4	3.4
5	#10480.00	57.0 PK	68.2	-11.2	2.60 V	133	41.6	15.4

Remarks:

1. Emission Level(dBuV/m) = Raw Value(dBuV) + Correction Factor(dB/m)
2. Correction Factor(dB/m) = Antenna Factor(dB/m) + Cable Factor(dB)
3. The other emission levels were very low against the limit.
4. Margin value = Emission Level – Limit value
5. " * ": Fundamental frequency.
6. " # ": The radiated frequency is out of the restricted band.

LTE Band 26 (BW: 3MHz) CH 27025 + BT LE CH 0
 LTE Band 26 (BW: 3MHz)

CHANNEL		27025					
Antenna Polarity & Test Distance: Horizontal at 3 m (For FCC Part 22)							
No.	Freq. (MHz)	Reading (dBm)	S.G Power Value (dBm)	Correction Factor (dB)	ERP (dBm)	Limit (dBm)	Margin (dB)
1	1695.00	-53.2	-45.7	0.7	-45.0	-13.0	-32.0
Antenna Polarity & Test Distance: Vertical at 3 m (For FCC Part 22)							
No.	Freq. (MHz)	Reading (dBm)	S.G Power Value (dBm)	Correction Factor (dB)	ERP (dBm)	Limit (dBm)	Margin (dB)
1	1695.00	-56.1	-48.8	0.7	-48.1	-13.0	-35.1

Remarks:

1. ERP (dBm) = S.G Value (dBm) + Correction Factor (dB).
2. Correction Factor (dB) = Substitution Antenna Gain (dB) + Cable Loss (dB).

BT LE

CHANNEL	0	DETECTOR FUNCTION	Peak (PK) Average (AV)
FREQUENCY RANGE	1GHz ~ 25GHz		

ANTENNA POLARITY & TEST DISTANCE: HORIZONTAL AT 3 m (For FCC 15.247)								
NO.	FREQ. (MHz)	EMISSION LEVEL (dBuV/m)	LIMIT (dBuV/m)	MARGIN (dB)	ANTENNA HEIGHT (m)	TABLE ANGLE (Degree)	RAW VALUE (dBuV)	CORRECTION FACTOR (dB/m)
1	2390.00	57.6 PK	74.0	-16.4	2.22 H	244	25.8	31.8
2	2390.00	45.4 AV	54.0	-8.6	2.22 H	244	13.6	31.8
3	*2402.00	98.1 PK			2.29 H	233	66.3	31.8
4	*2402.00	93.5 AV			2.29 H	233	61.7	31.8
5	4804.00	46.0 PK	74.0	-28.0	2.89 H	144	42.3	3.7
6	4804.00	32.7 AV	54.0	-21.3	2.89 H	144	29.0	3.7
ANTENNA POLARITY & TEST DISTANCE: VERTICAL AT 3 m (For FCC 15.247)								
NO.	FREQ. (MHz)	EMISSION LEVEL (dBuV/m)	LIMIT (dBuV/m)	MARGIN (dB)	ANTENNA HEIGHT (m)	TABLE ANGLE (Degree)	RAW VALUE (dBuV)	CORRECTION FACTOR (dB/m)
1	2390.00	57.9 PK	74.0	-16.1	1.23 V	240	26.1	31.8
2	2390.00	45.9 AV	54.0	-8.1	1.23 V	240	14.1	31.8
3	*2402.00	93.4 PK			1.28 V	249	61.6	31.8
4	*2402.00	88.5 AV			1.28 V	249	56.7	31.8
5	4804.00	45.0 PK	74.0	-29.0	1.62 V	260	41.3	3.7
6	4804.00	32.2 AV	54.0	-21.8	1.62 V	260	28.5	3.7

Remarks:

1. Emission Level(dBuV/m) = Raw Value(dBuV) + Correction Factor(dB/m)
2. Correction Factor(dB/m) = Antenna Factor(dB/m) + Cable Factor(dB)
3. The other emission levels were very low against the limit.
4. Margin value = Emission Level – Limit value
5. " * ": Fundamental frequency.
6. " # ": The radiated frequency is out of the restricted band.

LTE Band 26 (BW: 3MHz) CH 26775 + 802.11g CH 6
 LTE Band 26 (BW: 3MHz)

CHANNEL		26775					
Antenna Polarity & Test Distance: Horizontal at 3 m (For FCC Part 90S)							
No.	Freq. (MHz)	Reading (dBm)	S.G Power Value (dBm)	Correction Factor (dB)	ERP (dBm)	Limit (dBm)	Margin (dB)
1	1645.00	-52.5	-44.8	1.0	-43.8	-13.0	-30.8
Antenna Polarity & Test Distance: Vertical at 3 m (For FCC Part 90S)							
No.	Freq. (MHz)	Reading (dBm)	S.G Power Value (dBm)	Correction Factor (dB)	ERP (dBm)	Limit (dBm)	Margin (dB)
1	1645.00	-55.5	-48.2	1.0	-47.2	-13.0	-34.2

Remarks:

1. ERP (dBm) = S.G Value (dBm) + Correction Factor (dB).
2. Correction Factor (dB) = Substitution Antenna Gain (dB) + Cable Loss (dB).

802.11g

CHANNEL	6	DETECTOR FUNCTION	Peak (PK) Average (AV)
FREQUENCY RANGE	1GHz ~ 25GHz		

ANTENNA POLARITY & TEST DISTANCE: HORIZONTAL AT 3 m (For FCC 15.247)								
NO.	FREQ. (MHz)	EMISSION LEVEL (dBuV/m)	LIMIT (dBuV/m)	MARGIN (dB)	ANTENNA HEIGHT (m)	TABLE ANGLE (Degree)	RAW VALUE (dBuV)	CORRECTION FACTOR (dB/m)
1	*2437.00	113.6 PK			2.18 H	230	81.8	31.8
2	*2437.00	103.1 AV			2.18 H	230	71.3	31.8
3	4874.00	45.9 PK	74.0	-28.1	1.30 H	170	42.4	3.5
4	4874.00	33.3 AV	54.0	-20.7	1.30 H	170	29.8	3.5
ANTENNA POLARITY & TEST DISTANCE: VERTICAL AT 3 m (For FCC 15.247)								
NO.	FREQ. (MHz)	EMISSION LEVEL (dBuV/m)	LIMIT (dBuV/m)	MARGIN (dB)	ANTENNA HEIGHT (m)	TABLE ANGLE (Degree)	RAW VALUE (dBuV)	CORRECTION FACTOR (dB/m)
1	*2437.00	112.3 PK			1.19 V	146	80.5	31.8
2	*2437.00	102.2 AV			1.19 V	146	70.4	31.8
3	4874.00	38.3 PK	74.0	-35.7	2.88 V	199	34.8	3.5
4	4874.00	26.2 AV	54.0	-27.8	2.88 V	199	22.7	3.5

Remarks:

1. Emission Level(dBuV/m) = Raw Value(dBuV) + Correction Factor(dB/m)
2. Correction Factor(dB/m) = Antenna Factor(dB/m) + Cable Factor(dB)
3. The other emission levels were very low against the limit.
4. Margin value = Emission Level – Limit value
5. " * ": Fundamental frequency.

LTE Band 26 (BW: 3MHz) CH 26775 + 802.11n (HT20) CH 48
 LTE Band 26 (BW: 3MHz)

CHANNEL		26775					
Antenna Polarity & Test Distance: Horizontal at 3 m (For FCC Part 90S)							
No.	Freq. (MHz)	Reading (dBm)	S.G Power Value (dBm)	Correction Factor (dB)	ERP (dBm)	Limit (dBm)	Margin (dB)
1	1645.00	-52.0	-44.2	1.0	-43.2	-13.0	-30.2
Antenna Polarity & Test Distance: Vertical at 3 m (For FCC Part 90S)							
No.	Freq. (MHz)	Reading (dBm)	S.G Power Value (dBm)	Correction Factor (dB)	ERP (dBm)	Limit (dBm)	Margin (dB)
1	1645.00	-55.0	-47.8	1.0	-46.8	-13.0	-33.8

Remarks:

1. ERP (dBm) = S.G Value (dBm) + Correction Factor (dB).
2. Correction Factor (dB) = Substitution Antenna Gain (dB) + Cable Loss (dB).

802.11n (HT20)

CHANNEL	48	DETECTOR FUNCTION	Peak (PK) Average (AV)
FREQUENCY RANGE	1GHz ~ 25GHz		

ANTENNA POLARITY & TEST DISTANCE: HORIZONTAL AT 3 m (For FCC 15.247)								
NO.	FREQ. (MHz)	EMISSION LEVEL (dBuV/m)	LIMIT (dBuV/m)	MARGIN (dB)	ANTENNA HEIGHT (m)	TABLE ANGLE (Degree)	RAW VALUE (dBuV)	CORRECTION FACTOR (dB/m)
1	*5240.00	111.2 PK			1.49 H	179	73.5	37.7
2	*5240.00	100.1 AV			1.49 H	179	62.4	37.7
3	5350.00	53.9 PK	74.0	-20.1	1.43 H	169	50.5	3.4
4	5350.00	43.4 AV	54.0	-10.6	1.43 H	169	40.0	3.4
5	#10480.00	55.4 PK	68.2	-12.8	1.19 H	221	40.0	15.4
ANTENNA POLARITY & TEST DISTANCE: VERTICAL AT 3 m (For FCC 15.247)								
NO.	FREQ. (MHz)	EMISSION LEVEL (dBuV/m)	LIMIT (dBuV/m)	MARGIN (dB)	ANTENNA HEIGHT (m)	TABLE ANGLE (Degree)	RAW VALUE (dBuV)	CORRECTION FACTOR (dB/m)
1	*5240.00	112.8 PK			1.20 V	169	75.1	37.7
2	*5240.00	101.6 AV			1.20 V	169	63.9	37.7
3	5350.00	55.6 PK	74.0	-18.4	1.21 V	160	52.2	3.4
4	5350.00	44.2 AV	54.0	-9.8	1.21 V	160	40.8	3.4
5	#10480.00	57.5 PK	68.2	-10.7	2.55 V	109	42.1	15.4

Remarks:

1. Emission Level(dBuV/m) = Raw Value(dBuV) + Correction Factor(dB/m)
2. Correction Factor(dB/m) = Antenna Factor(dB/m) + Cable Factor(dB)
3. The other emission levels were very low against the limit.
4. Margin value = Emission Level – Limit value
5. " * ": Fundamental frequency.
6. " # ": The radiated frequency is out of the restricted band.

LTE Band 26 (BW: 3MHz) CH 26775 + BT LE CH 0
 LTE Band 26 (BW: 3MHz)

CHANNEL		26775					
Antenna Polarity & Test Distance: Horizontal at 3 m (For FCC Part 90S)							
No.	Freq. (MHz)	Reading (dBm)	S.G Power Value (dBm)	Correction Factor (dB)	ERP (dBm)	Limit (dBm)	Margin (dB)
1	1645.00	-52.8	-45.0	1.0	-44.0	-13.0	-31.0
Antenna Polarity & Test Distance: Vertical at 3 m (For FCC Part 90S)							
No.	Freq. (MHz)	Reading (dBm)	S.G Power Value (dBm)	Correction Factor (dB)	ERP (dBm)	Limit (dBm)	Margin (dB)
1	1645.00	-55.2	-48.0	1.0	-47.0	-13.0	-34.0

Remarks:

1. ERP (dBm) = S.G Value (dBm) + Correction Factor (dB).
2. Correction Factor (dB) = Substitution Antenna Gain (dB) + Cable Loss (dB).

BT LE

CHANNEL	0	DETECTOR FUNCTION	Peak (PK) Average (AV)
FREQUENCY RANGE	1GHz ~ 25GHz		

ANTENNA POLARITY & TEST DISTANCE: HORIZONTAL AT 3 m (For FCC 15.247)								
NO.	FREQ. (MHz)	EMISSION LEVEL (dBuV/m)	LIMIT (dBuV/m)	MARGIN (dB)	ANTENNA HEIGHT (m)	TABLE ANGLE (Degree)	RAW VALUE (dBuV)	CORRECTION FACTOR (dB/m)
1	2390.00	58.1 PK	74.0	-15.9	2.30 H	252	26.3	31.8
2	2390.00	45.6 AV	54.0	-8.4	2.30 H	252	13.8	31.8
3	*2402.00	98.4 PK			2.30 H	252	66.6	31.8
4	*2402.00	94.0 AV			2.30 H	256	62.2	31.8
5	4804.00	46.2 PK	74.0	-27.8	2.80 H	166	42.5	3.7
6	4804.00	33.2 AV	54.0	-20.8	2.80 H	166	29.5	3.7
ANTENNA POLARITY & TEST DISTANCE: VERTICAL AT 3 m (For FCC 15.247)								
NO.	FREQ. (MHz)	EMISSION LEVEL (dBuV/m)	LIMIT (dBuV/m)	MARGIN (dB)	ANTENNA HEIGHT (m)	TABLE ANGLE (Degree)	RAW VALUE (dBuV)	CORRECTION FACTOR (dB/m)
1	2390.00	57.4 PK	74.0	-16.6	1.13 V	226	25.6	31.8
2	2390.00	45.4 AV	54.0	-8.6	1.13 V	226	13.6	31.8
3	*2402.00	93.0 PK			1.00 V	221	61.2	31.8
4	*2402.00	88.1 AV			1.00 V	221	56.3	31.8
5	4804.00	45.2 PK	74.0	-28.8	1.54 V	230	41.5	3.7
6	4804.00	32.1 AV	54.0	-21.9	1.54 V	230	28.4	3.7

Remarks:

1. Emission Level(dBuV/m) = Raw Value(dBuV) + Correction Factor(dB/m)
2. Correction Factor(dB/m) = Antenna Factor(dB/m) + Cable Factor(dB)
3. The other emission levels were very low against the limit.
4. Margin value = Emission Level – Limit value
5. " * ": Fundamental frequency.

5 Pictures of Test Arrangements

Please refer to the attached file (Test Setup Photo).

Appendix – Information of the Testing Laboratories

We, Bureau Veritas Consumer Products Services (H.K.) Ltd., Taoyuan Branch, were founded in 1988 to provide our best service in EMC, Radio, Telecom and Safety consultation. Our laboratories are accredited and approved according to ISO/IEC 17025.

If you have any comments, please feel free to contact us at the following:

Linko EMC/RF Lab

Tel: 886-2-26052180

Fax: 886-2-26051924

Hsin Chu EMC/RF/Telecom Lab

Tel: 886-3-6668565

Fax: 886-3-6668323

Hwa Ya EMC/RF/Safety Lab

Tel: 886-3-3183232

Fax: 886-3-3270892

Email: service.adt@tw.bureauveritas.com

Web Site: www.bureauveritas-adt.com

The address and road map of all our labs can be found in our web site also.

--- END ---