

# FCC Test Report

Product Name	DCM (Data Communication Module)
Model No.	5-104348-192
FCC ID.	H8NCDD6020

Applicant	ASKEY COMPUTER CORP.
Address	10F, NO.119, JIANKANG RD., ZHONGHE DIST., NEW TAIPEI CITY 23585

Date of Receipt	Oct. 13, 2017
Issued Date	Nov. 28, 2017
Report No.	17A0157R-RFUSP26V00
Report Version	V1.0



The test results relate only to the samples tested.

The test results shown in the test report are traceable to the national/international standard through the calibration report of the equipment and evaluated measurement uncertainty herein.

This report must not be used to claim product endorsement by TAF or any agency of the government.

The test report shall not be reproduced without the written approval of DEKRA Testing and Certification Co., Ltd..

# Test Report

Issued Date: Nov. 28, 2017

Report No.: 17A0157R-RFUSP26V00



Product Name	DCM (Data Communication Module)
Applicant	ASKEY COMPUTER CORP.
Address	10F, NO.119, JIANKANG RD., ZHONGHE DIST., NEW TAIPEI CITY 23585
Manufacturer	ASKEY COMPUTER CORP.
Model No.	5-104348-192
FCC ID.	H8NCDD6020
EUT Rated Voltage	DC 12V (Power by Battery)
EUT Test Voltage	DC 12V (Power by Battery)
Trade Name	DENSO CORPORATION
Applicable Standard	FCC CFR Title 47 Part 15 Subpart C: 2016 ANSI C63.4: 2014, ANSI C63.10: 2013 KDB 558074 D01 DTS Meas Guidance v04
Test Result	Complied

Documented By :

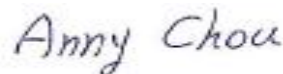

( Senior Adm. Specialist / Anny Chou )

Tested By :



( Engineer / Eason Chen )

Approved By :



( Director / Vincent Lin )

## TABLE OF CONTENTS

Description	Page
<b>1. GENERAL INFORMATION .....</b>	<b>4</b>
1.1. EUT Description.....	4
1.2. Operational Description.....	7
1.3. Tested System Details.....	8
1.4. Configuration of Tested System .....	8
1.5. EUT Exercise Software .....	9
1.6. Test Facility .....	10
1.7. List of Test Equipment.....	11
<b>2. CONDUCTED EMISSION .....</b>	<b>12</b>
2.1. Test Setup .....	12
2.2. Limits.....	13
2.3. Test Procedure .....	13
2.4. Uncertainty .....	13
2.5. Test Result of Conducted Emission.....	14
<b>3. PEAK POWER OUTPUT .....</b>	<b>15</b>
3.1. Test Setup .....	15
3.2. Limit .....	15
3.3. Test Procedure .....	15
3.4. Uncertainty .....	15
3.5. Test Result of Peak Power Output.....	16
<b>4. RADIATED EMISSION .....</b>	<b>17</b>
4.1. Test Setup .....	17
4.2. Limits.....	19
4.3. Test Procedure .....	20
4.4. Uncertainty .....	20
4.5. Test Result of Radiated Emission.....	21
<b>5. RF ANTENNA CONDUCTED TEST .....</b>	<b>25</b>
5.1. Test Setup .....	25
5.2. Limits.....	25
5.3. Test Procedure .....	25
5.4. Uncertainty .....	25
5.5. Test Result of RF Antenna Conducted Test.....	26
<b>6. BAND EDGE .....</b>	<b>27</b>
6.1. Test Setup .....	27
6.2. Limit .....	28
6.3. Test Procedure .....	28
6.4. Uncertainty .....	28
6.5. Test Result of Band Edge .....	29
<b>7. 6DB BANDWIDTH .....</b>	<b>33</b>
7.1. Test Setup .....	33
7.2. Limits.....	33
7.3. Test Procedure .....	33
7.4. Uncertainty .....	33
7.5. Test Result of 6dB Bandwidth.....	34
<b>8. POWER DENSITY .....</b>	<b>37</b>
8.1. Test Setup .....	37
8.2. Limits.....	37
8.3. Test Procedure .....	37
8.4. Uncertainty .....	37
8.5. Test Result of Power Density .....	38
<b>9. EMI REDUCTION METHOD DURING COMPLIANCE TESTING .....</b>	<b>41</b>
Attachment 1: EUT Test Photographs	
Attachment 2: EUT Detailed Photographs	

## 1. GENERAL INFORMATION

### 1.1. EUT Description

Product Name	DCM (Data Communication Module)
Trade Name	DENSO CORPORATION
Model No.	5-104348-192
FCC ID.	H8NCDD6020
Frequency Range	2402 – 2480MHz
Channel Number	V4.1: 40CH
Type of Modulation	V4.1: GFSK(1Mbps)
Antenna Type	PIFA Antenna
Channel Control	Auto
Antenna Gain	Refer to the table “Antenna List”

#### Antenna List

No.	Manufacturer	Part No.	Antenna Type	Peak Gain
1	ASKEY	CDD6020	PIFA Antenna	2.74dBi for 2.4GHz

Note: The antenna of EUT is conforming to FCC 15.203.

Center Frequency of Each Channel: (For V4.1)

Channel	Frequency	Channel	Frequency	Channel	Frequency	Channel	Frequency
Channel 00:	2402 MHz	Channel 01:	2404 MHz	Channel 02:	2406 MHz	Channel 03:	2408 MHz
Channel 04:	2410 MHz	Channel 05:	2412 MHz	Channel 06:	2414 MHz	Channel 07:	2416 MHz
Channel 08:	2418 MHz	Channel 09:	2420 MHz	Channel 10:	2422 MHz	Channel 11:	2424 MHz
Channel 12:	2426 MHz	Channel 13:	2428 MHz	Channel 14:	2430 MHz	Channel 15:	2432 MHz
Channel 16:	2434 MHz	Channel 17:	2436 MHz	Channel 18:	2438 MHz	Channel 19:	2440 MHz
Channel 20:	2442 MHz	Channel 21:	2444 MHz	Channel 22:	2446 MHz	Channel 23:	2448 MHz
Channel 24:	2450 MHz	Channel 25:	2452 MHz	Channel 26:	2454 MHz	Channel 27:	2456 MHz
Channel 28:	2458 MHz	Channel 29:	2460 MHz	Channel 30:	2462 MHz	Channel 31:	2464 MHz
Channel 32:	2466 MHz	Channel 33:	2468 MHz	Channel 34:	2470 MHz	Channel 35:	2472 MHz
Channel 36:	2474 MHz	Channel 37:	2476 MHz	Channel 38:	2478 MHz	Channel 39:	2480 MHz

Duty Cycle:

BLE	0.620
-----	-------

\*Duty cycle = Ton / (Ton + Toff)

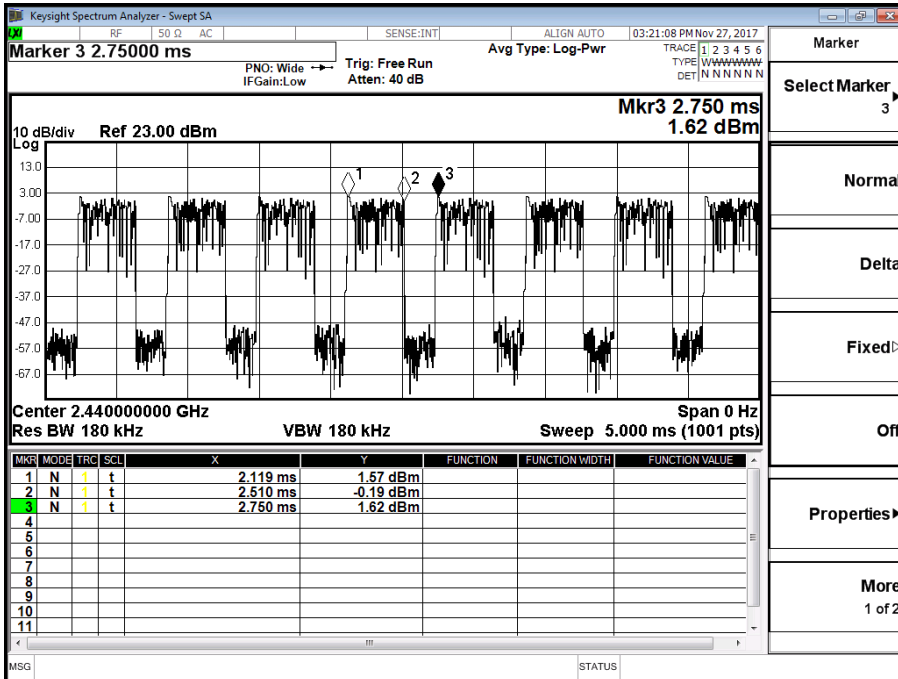

Note:

1. The EUT is a DCM (Data Communication Module) with a built-in WLAN + Bluetooth transceiver, this report for Bluetooth V4.1.
2. These tests were conducted on a sample for the purpose of demonstrating compliance of Bluetooth transmitter with Part 15 Subpart C Paragraph 15.247 for spread spectrum devices.
3. Regarding to the operation frequency, the lowest, middle and highest frequency are selected to perform the test.
4. The radiation measurements are performed in X, Y, Z axis positioning. Only the worst case is shown in the report.

Test Mode	Mode 1: Transmit - BLE (GFSK)
-----------	-------------------------------

### 1.3. Tested System Details

The types for all equipment, plus descriptions of all cables used in the tested system (including inserted cards) are:

	Product	Manufacturer	Model No.	Serial No.	Power Cord
1	Digital camera	ASKEY	N/A	N/A	N/A
2	Note Book	DELL	Inspiron 15 3000	N/A	N/A
3	LTE Antenna	ASKEY	N/A	N/A	N/A
4	GPS Antenna	ASKEY	N/A	N/A	Non-shielded, 1.4m
5	Battery (DC 12V)	TRANE	12B50PE	N/A	N/A
6	FLASH	Transcend	JF110	132706-1218	N/A

Signal Cable Type	Signal cable Description
A Power Cable	Non-shielded, 0.5m
B USB Cable	Non-shielded, 0.4m
C USB Cable	Non-shielded, 1.4m
D Signal Cable	Non-shielded, 1.2m
E Signal Cable	Non-shielded, 2.9m
F Signal Cable	Non-shielded, 1.4m, two PCS
G Signal Cable	Non-shielded, 1.4m

### 1.4. Configuration of Tested System

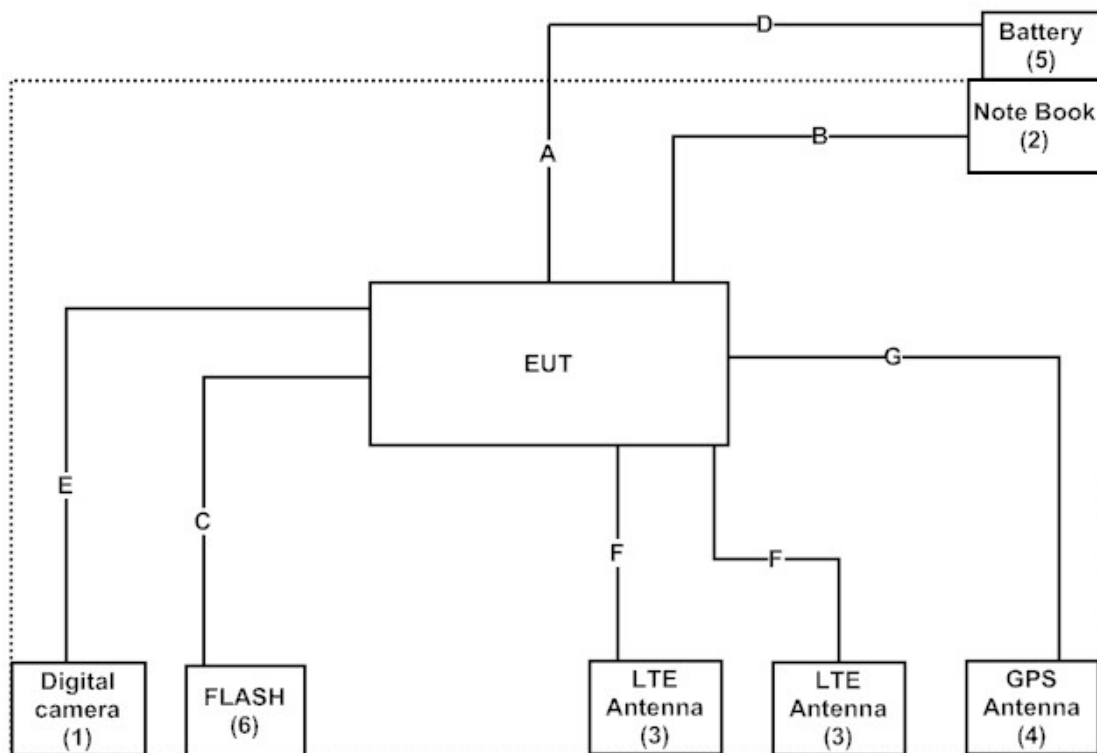

## 1.5. EUT Exercise Software

1. Setup the EUT as shown in Section 1.4.
2. Execute software "QRCT V3.0.230.0" on the Notebook PC.
3. Configure the test mode, the test channel, and the data rate.
4. Press "OK" to start the continuous Transmit.
5. Verify that the EUT works properly.



## 1.6. Test Facility

Ambient conditions in the laboratory:

Items	Required (IEC 68-1)	Actual
Temperature (°C)	15-35	20-35
Humidity (%RH)	25-75	30-65
Barometric pressure (mbar)	860-1060	950-1000

The related certificate for our laboratories about the test site and management system can be downloaded from DEKRA Testing and Certification Co., Ltd. Web Site:

<http://www.dekra.com.tw/english/about/certificates.aspx?bval=5>

The address and introduction of DEKRA Testing and Certification Co., Ltd. laboratories can be founded in our Web site: [http://www.dekra.com.tw/index\\_en.aspx](http://www.dekra.com.tw/index_en.aspx)

Site Description: Accredited by TAF  
Accredited Number: 3023

Site Name: DEKRA Testing and Certification Co., Ltd  
Site Address: No.5-22, Ruishukeng, Linkou Dist., New Taipei City 24451,  
Taiwan, R.O.C.  
TEL : 886-2-8601-3788 / FAX : 886-2-8601-3789  
E-Mail : [info.tw@dekra.com](mailto:info.tw@dekra.com)

FCC Accreditation Number: TW3023

## 1.7. List of Test Equipment

### For Conducted measurements /CB3/SR8

	Equipment	Manufacturer	Model No.	Serial No.	Cali. Date	Due. Date
X	Spectrum Analyzer	Agilent	N9010A	MY48030495	2017/7/22	2018/7/21
X	Power Meter	Anritsu	ML2495A	6K00003357	2017/6/23	2018/6/22
X	EMI Test Receiver	R&S	ESCS 30	100369	2017/10/13	2018/10/12
X	LISN	R&S	ESH3-Z5	836679/017	2017/1/7	2018/1/6
X	LISN	R&S	ENV216	100097	2017/1/7	2018/1/6
X	Coaxial Cable	QTK(Arnist)	RG 400	LC018-RG	2017/6/25	2018/6/24

### For Radiated measurements /Site3/CB8

	Equipment	Manufacturer	Model No.	Serial No.	Cali. Date	Due. Date
X	Spectrum Analyzer	R&S	FSP40	100170	2017/1/5	2018/1/4
X	Loop Antenna	Teseq	HLA6121	37133	2017/3/18	2018/3/17
X	Bi-Log Antenna	Schaffner Chase	CBL6112B	2707	2017/9/10	2018/9/9
X	Horn Antenna	ETS-Lindgren	3117	00135205	2017/4/6	2018/4/5
X	Horn Antenna	Schwarzbeck	BBHA9170	9170430	2017/1/11	2018/1/10
X	Pre-Amplifier	QTK	AP/0100A	CHM/0901069	2017/6/28	2018/6/27
X	Pre-Amplifier	EMCI	EMC012630SE	980210	2017/1/27	2018/1/26
X	Pre-Amplifier	NARDA WE	DBL-1840N506	013	2017/9/30	2018/9/29
X	Filter	MicroTRON	BRM50701	019	2017/10/20	2018/10/19
	Filter	Microwave Circuits	N0257881	36681	2016/12/7	2017/12/6
X	EMI Test Receiver	R&S	ESR26	101385	2017/9/29	2018/9/28
X	Coaxial Cable	QTK(Arnist)	SUCOFLEX 106	L1606-015C	2017/6/25	2018/6/24
X	EMI Test Receiver	R&S	ESCS 30	838251/001	2017/7/21	2018/7/20
X	Coaxial Cable	QTK(Arnist)	RG 214	LC003-RG	2017/6/21	2018/6/20
X	Coaxial signal switch	Anritsu	MP59B	6201415889	2017/6/16	2018/6/15

Note:

1. All equipments are calibrated every one year.
2. The test instruments marked with "X" are used to measure the final test results.
3. Test Software version : QuieTek EMI 2.0 V2.1.113

## 2. Conducted Emission

### 2.1. Test Setup

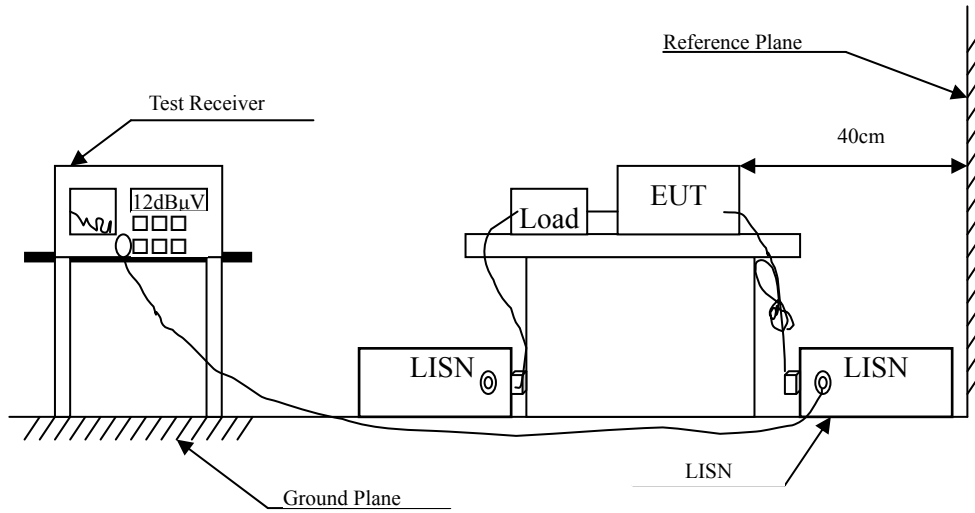

## 2.2. Limits

<b>FCC Part 15 Subpart C Paragraph 15.207 (dB<math>\mu</math>V) Limit</b>		
Frequency MHz	Limits	
	QP	AV
0.15 - 0.50	66-56	56-46
0.50-5.0	56	46
5.0 - 30	60	50

Remarks: In the above table, the tighter limit applies at the band edges.

## 2.3. Test Procedure

The EUT and Peripherals are connected to the main power through a line impedance stabilization network (L.I.S.N.). This provides a 50 ohm /50uH coupling impedance for the measuring equipment. The peripheral devices are also connected to the main power through a LISN that provides a 50ohm /50uH coupling impedance with 50ohm termination. (Please refer to the block diagram of the test setup and photographs.)

Both sides of A.C. line are checked for maximum conducted interference. In order to find the maximum emission, the relative positions of equipment and all the interface cables must be changed according to ANSI C63.4: 2014 on conducted measurement.

Conducted emissions were investigated over the frequency range from 0.15MHz to 30MHz using a receiver bandwidth of 9kHz.

The EUT was setup to ANSI C63.4, 2014; tested to DTS test procedure of FCC KDB-558074 for compliance to FCC 47CFR Subpart C requirements.

## 2.4. Uncertainty

$\pm 2.26$  dB

---

## **2.5. Test Result of Conducted Emission**

Owing to the DC operation of EUT, this test item is not performed.

### 3. Peak Power Output

#### 3.1. Test Setup

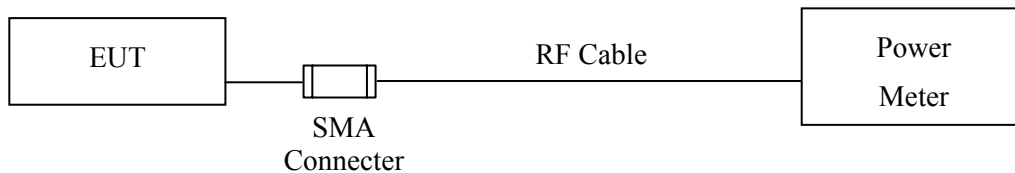

#### 3.2. Limit

The maximum peak power shall be less 1Watt.

#### 3.3. Test Procedure

Tested according to DTS test procedure of KDB 558074 for compliance to FCC 47CFR 15.247 requirements. The maximum peak conducted output power using KDB 558074 section 9.1.3 PKPM1 Peak power meter method.

#### 3.4. Uncertainty

$\pm 1.19$  dB

### 3.5. Test Result of Peak Power Output

Product : DCM (Data Communication Module)  
Test Item : Peak Power Output  
Test Site : No.3 OATS  
Test date : 2017/11/16  
Test Mode : Mode 1: Transmit - BLE (GFSK)

Channel No.	Frequency (MHz)	Measurement (dBm)	Required Limit	Result
Channel 00	2402.00	2.09	1 Watt= 30 dBm	Pass
Channel 19	2440.00	2.78	1 Watt= 30 dBm	Pass
Channel 39	2480.00	1.39	1 Watt= 30 dBm	Pass

#### 4. Radiated Emission

##### 4.1. Test Setup

Under 30MHz

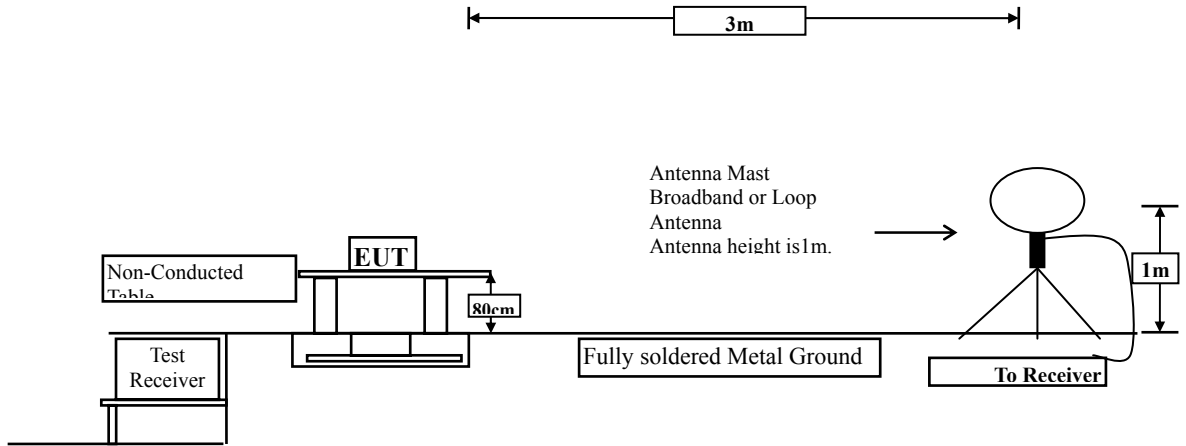

Below 1GHz

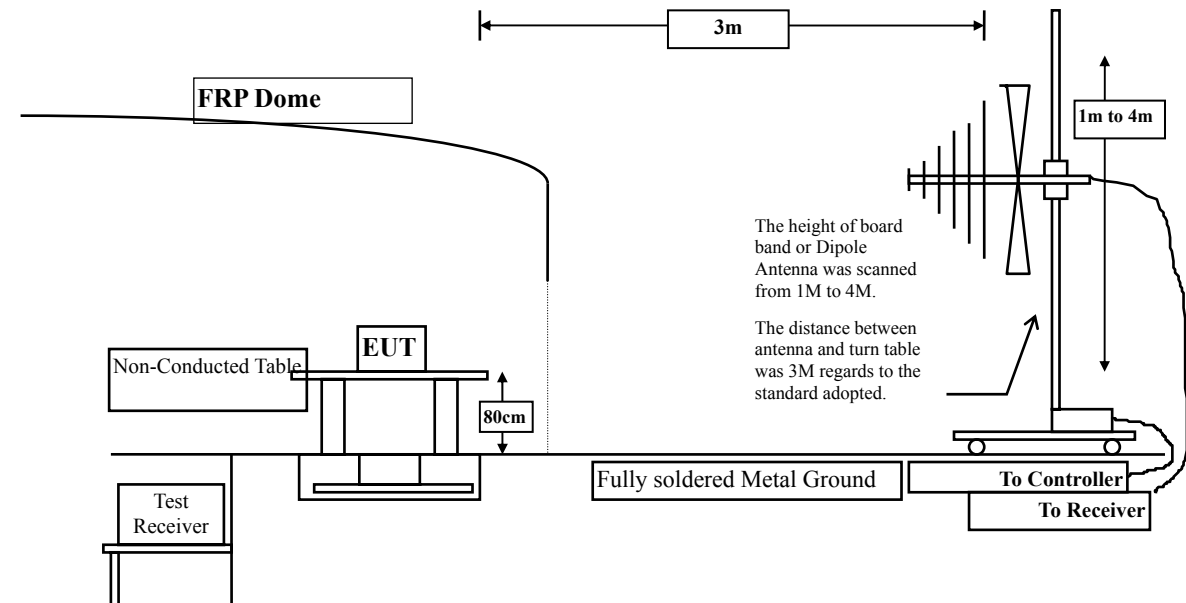



Above 1GHz

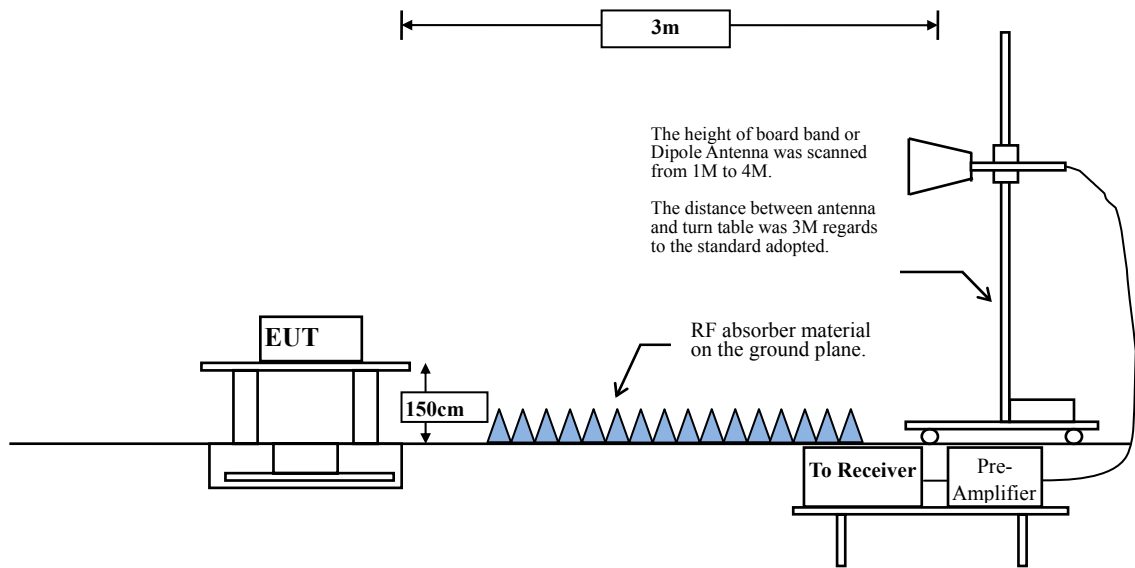

## 4.2. Limits

### ➤ General Radiated Emission Limits

Emissions radiated outside of the specified frequency bands, except for harmonics, shall be attenuated by at least 20dB below the level of the fundamental or to the general radiated emission limits in paragraph 15.209, whichever is the lesser attenuation.

<b>FCC Part 15 Subpart C Paragraph 15.209 Limits</b>		
Frequency MHz	Field strength (microvolts/meter)	Measurement distance (meter)
0.009-0.490	2400/F(kHz)	300
0.490-1.705	24000/F(kHz)	30
1.705-30	30	30
30-88	100	3
88-216	150	3
216-960	200	3
Above 960	500	3

- Remarks:
1. RF Voltage (dB $\mu$ V) = 20 log RF Voltage (uV)
  2. In the Above Table, the tighter limit applies at the band edges.
  3. Distance refers to the distance in meters between the measuring instrument antenna and the closed point of any part of the device or system.

### 4.3. Test Procedure

The EUT was setup according to ANSI C63.10: 2013 and tested according to DTS test procedure of KDB558074 for compliance to FCC 47CFR 15.247 requirements.

Measuring the frequency range below 1GHz, the EUT is placed on a turn table which is 0.8 meter above ground, when measuring the frequency range above 1GHz, the EUT is placed on a turn table which is 1.5 meter above ground.

The turn table is rotated 360 degrees to determine the position of the maximum emission level.

The EUT was positioned such that the distance from antenna to the EUT was 3 meters.

The antenna is scanned between 1 meter and 4 meters to find out the maximum emission level. This is repeated for both horizontal and vertical polarization of the antenna. In order to find the maximum emission, all of the interface cables were manipulated according to ANSI C63.10: 2013 on radiated measurement.

The resolution bandwidth below 30MHz setting on the field strength meter is 9kHz and 30MHz~1GHz is 120kHz and above 1GHz is 1MHz.

Radiated emission measurements below 30MHz are made using Loop Antenna and 30MHz~1GHz are made using broadband Bilog antenna and above 1GHz are made using Horn Antennas.

The measurement is divided into the Preliminary Measurement and the Final Measurement.

The suspected frequencies are searched for in Preliminary Measurement with the measurement antenna kept pointed at the source of the emission both in azimuth and elevation, with the polarization of the antenna oriented for maximum response. The antenna is pointed at an angle towards the source of the emission, and the EUT is rotated in both height and polarization to maximize the measured emission. The emission is kept within the illumination area of the 3 dB bandwidth of the antenna.

The worst radiated emission is measured in the Open Area Test Site on the Final Measurement.

The measurement frequency range from 9kHz - 10th Harmonic of fundamental was investigated.

The average measurement tested according to KDB 558074 section 12.2.5.3. Reduced VBW averaging across on- and off-times of the EUT transmissions with max hold.

$VBW \geq 1/T$ :

Duty Cycle	T	1/T	VBW Setting
0.620	0.391	2557	3 kHz

### 4.4. Uncertainty

± 4.08 dB above 1GHz

± 4.22 dB below 1GHz

#### 4.5. Test Result of Radiated Emission

Product : DCM (Data Communication Module)  
 Test Item : Harmonic Radiated Emission  
 Test Site : No.3 OATS  
 Test date : 2017/11/15  
 Test Mode : Mode 1: Transmit - BLE (GFSK)(2402MHz)

Frequency MHz	Correct Factor dB	Reading Level dB $\mu$ V	Measurement Level dB $\mu$ V/m	Margin dB	Limit dB $\mu$ V/m
<b>Horizontal</b>					
<b>Peak Detector:</b>					
4804.000	2.511	39.715	42.225	-31.775	74.000
7206.000	9.511	37.014	46.525	-27.475	74.000
9608.000	10.394	36.494	46.888	-27.112	74.000
<b>Average Detector:</b>					
--					
<b>Vertical</b>					
<b>Peak Detector:</b>					
4804.000	2.923	40.730	43.652	-30.348	74.000
7206.000	9.988	38.236	48.225	-25.775	74.000
9608.000	10.847	35.700	46.547	-27.453	74.000
<b>Average Detector:</b>					
--					

Note:

1. All Readings below 1GHz are Quasi-Peak, above 1GHz are performed with peak and/or average measurements as necessary.
2. Peak measurements: RBW = 1MHz, VBW = 3 MHz, Sweep: Auto.
3. Average measurements: RBW = 1MHz, VBW = 3 kHz, Sweep: Auto.
4. Measurement Level = Reading Level + Correct Factor.
5. Correct Factor = Antenna factor + Cable loss – Amplifier gain.
6. The average measurement was not performed when the peak measured data under the limit of average detection.
7. The emission levels of other frequencies are very lower than the limit and not show in test report.

Product : DCM (Data Communication Module)  
 Test Item : Harmonic Radiated Emission  
 Test Site : No.3 OATS  
 Test date : 2017/11/15  
 Test Mode : Mode 1: Transmit - BLE (GFSK) (2440MHz)

Frequency MHz	Correct Factor dB	Reading Level dB $\mu$ V	Measurement Level dB $\mu$ V/m	Margin dB	Limit dB $\mu$ V/m
<b>Horizontal</b>					
<b>Peak Detector:</b>					
4880.000	2.038	40.287	42.325	-31.675	74.000
7320.000	9.699	37.245	46.944	-27.056	74.000
9760.000	9.665	37.545	47.210	-26.790	74.000
<b>Average Detector:</b>					
--					
<b>Vertical</b>					
<b>Peak Detector:</b>					
4880.000	2.499	39.931	42.430	-31.570	74.000
7320.000	10.303	36.204	46.507	-27.493	74.000
9760.000	10.299	37.278	47.578	-26.422	74.000
<b>Average Detector:</b>					
--					

## Note:

- All Readings below 1GHz are Quasi-Peak, above 1GHz are performed with peak and/or average measurements as necessary.
- Peak measurements: RBW = 1MHz, VBW = 3 MHz, Sweep: Auto.
- Average measurements: RBW = 1MHz, VBW = 3 kHz, Sweep: Auto.
- Measurement Level = Reading Level + Correct Factor.
- Correct Factor = Antenna factor + Cable loss – Amplifier gain.
- The average measurement was not performed when the peak measured data under the limit of average detection.
- The emission levels of other frequencies are very lower than the limit and not show in test report.

Product : DCM (Data Communication Module)  
 Test Item : Harmonic Radiated Emission  
 Test Site : No.3 OATS  
 Test date : 2017/11/15  
 Test Mode : Mode 1: Transmit - BLE (GFSK) (2480MHz)

Frequency MHz	Correct Factor dB	Reading Level dB $\mu$ V	Measurement Level dB $\mu$ V/m	Margin dB	Limit dB $\mu$ V/m
<b>Horizontal</b>					
<b>Peak Detector:</b>					
4960.000	2.582	39.754	42.336	-31.664	74.000
7440.000	10.555	35.759	46.314	-27.686	74.000
9920.000	10.206	37.008	47.214	-26.786	74.000
<b>Average Detector:</b>					
--					
<b>Vertical</b>					
<b>Peak Detector:</b>					
4960.000	3.398	39.556	42.955	-31.045	74.000
7440.000	11.214	35.122	46.336	-27.664	74.000
9920.000	11.245	36.260	47.505	-26.495	74.000
<b>Average Detector:</b>					
--					

## Note:

- All Readings below 1GHz are Quasi-Peak, above 1GHz are performed with peak and/or average measurements as necessary.
- Peak measurements: RBW = 1MHz, VBW = 3 MHz, Sweep: Auto.
- Average measurements: RBW = 1MHz, VBW = 3 kHz, Sweep: Auto.
- Measurement Level = Reading Level + Correct Factor.
- Correct Factor = Antenna factor + Cable loss – Amplifier gain.
- The average measurement was not performed when the peak measured data under the limit of average detection.
- The emission levels of other frequencies are very lower than the limit and not show in test report.

Product : DCM (Data Communication Module)  
 Test Item : General Radiated Emission  
 Test Site : No.3 OATS  
 Test date : 2017/11/14  
 Test Mode : Mode 1: Transmit - BLE (GFSK) (2440MHz)

Frequency MHz	Correct Factor dB	Reading Level dB $\mu$ V	Measurement Level dB $\mu$ V/m	Margin dB	Limit dB $\mu$ V/m
<b>Horizontal</b>					
239.520	-6.878	40.073	33.195	-12.805	46.000
442.250	0.206	34.305	34.511	-11.489	46.000
556.710	2.695	33.344	36.039	-9.961	46.000
647.890	1.609	32.926	34.536	-11.464	46.000
742.950	3.904	31.421	35.325	-10.675	46.000
856.440	7.114	24.720	31.834	-14.166	46.000
<b>Vertical</b>					
216.240	-6.051	38.972	32.921	-13.079	46.000
288.020	-5.487	41.776	36.289	-9.711	46.000
407.330	-4.457	36.672	32.215	-13.785	46.000
551.860	-1.200	36.226	35.026	-10.974	46.000
647.890	-3.171	32.926	29.756	-16.244	46.000
782.720	2.757	29.061	31.818	-14.182	46.000

## Note:

- All Readings below 1GHz are Quasi-Peak, above 1GHz are performed with peak and/or average measurements as necessary.
- Peak measurements: RBW = 1MHz, VBW = 3 MHz, Sweep: Auto.
- Average measurements: RBW = 1MHz, VBW = 3 kHz, Sweep: Auto.
- Measurement Level = Reading Level + Correct Factor.
- Correct Factor = Antenna factor + Cable loss – Amplifier gain.
- The average measurement was not performed when the peak measured data under the limit of average detection.
- The emission levels of other frequencies are very lower than the limit and not show in test report.
- No emission found between lowest internal used/generated frequency to 30MHz.

## 5. RF Antenna Conducted Test

### 5.1. Test Setup

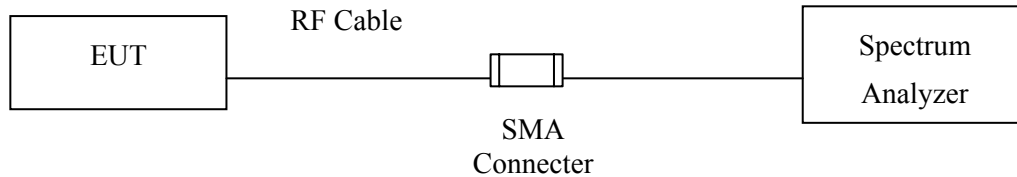

### 5.2. Limits

According to FCC Section 15.247(d). In any 100 kHz bandwidth outside the frequency band in which the spread spectrum or digitally modulated intentional radiator is operating, the radio frequency power that is produced by the intentional radiator shall be at least 20 dB below that in the 100 kHz bandwidth within the band that contains the highest level of the desired power, based on either an RF conducted or measurement, provided the transmitter demonstrates compliance with the peak conducted power limits. If the transmitter complies with the conducted power limits based on the use of RMS averaging over a time interval, the attenuation required under this paragraph shall be 30 dB instead of 20 dB.

### 5.3. Test Procedure

The EUT was tested according to DTS test procedure of KDB558074 for compliance to FCC 47CFR 15.247 requirements.

### 5.4. Uncertainty

$\pm 1.20\text{dB}$



### 5.5. Test Result of RF Antenna Conducted Test

Product : DCM (Data Communication Module)  
Test Item : RF Antenna Conducted Test  
Test Site : No.3 OATS  
Test date : 2017/11/16  
Test Mode : Mode 1: Transmit - BLE (GFSK)

**Figure Channel 00:**

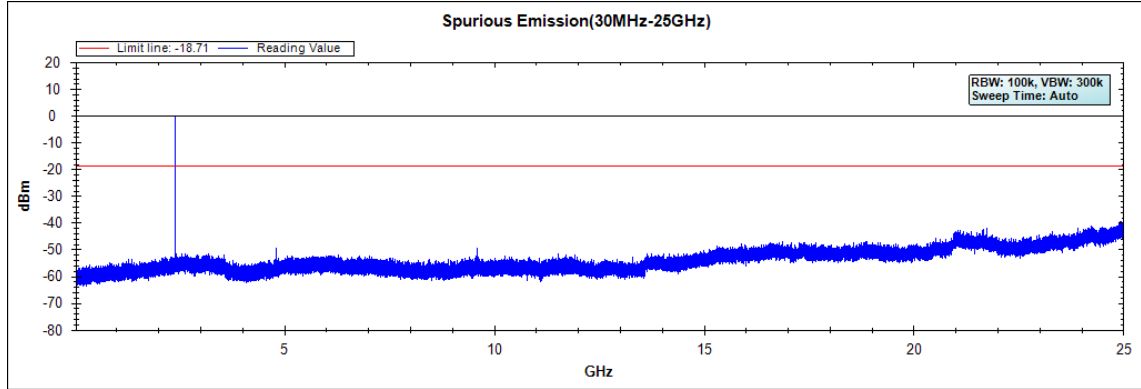

**Figure Channel 19:**

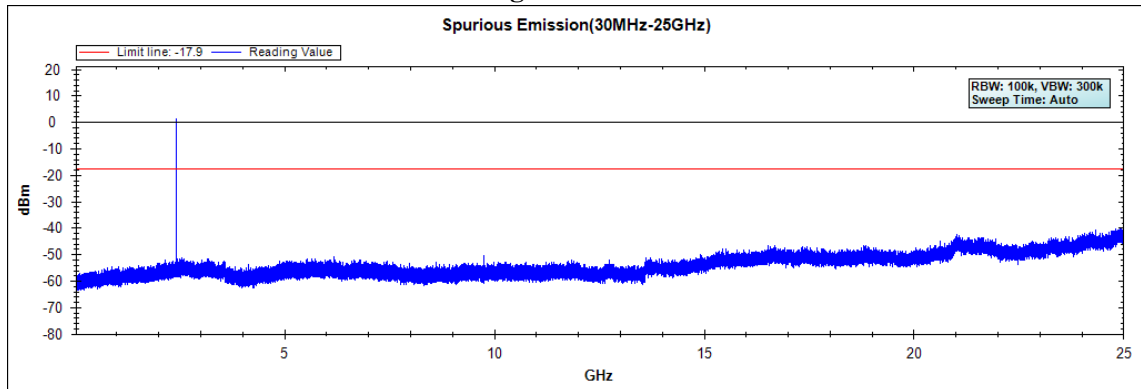

**Figure Channel 39:**

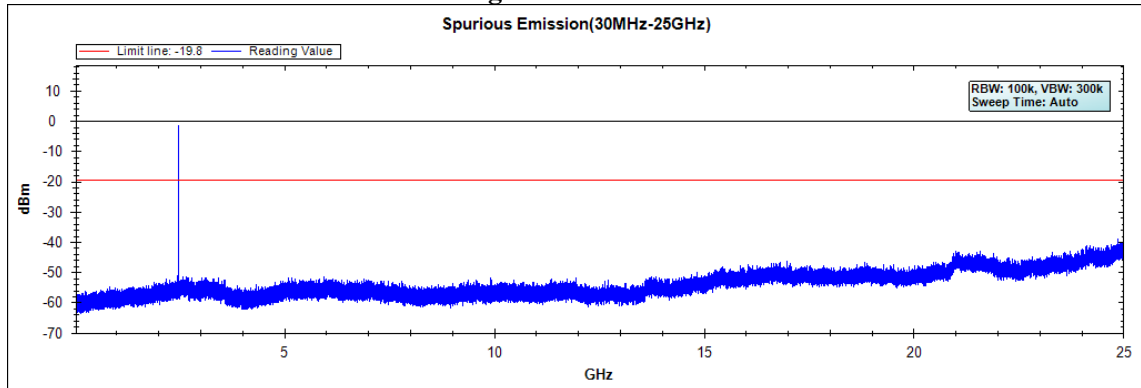

## 6. Band Edge

### 6.1. Test Setup

#### RF Conducted Measurement

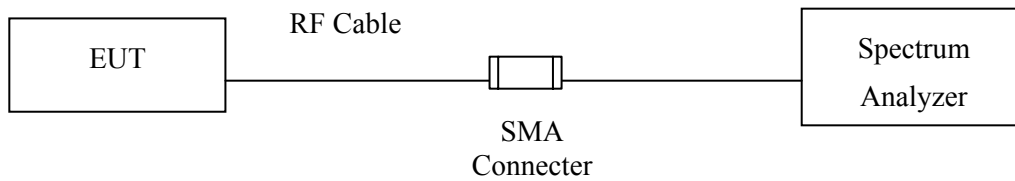

#### RF Radiated Measurement:

Above 1GHz

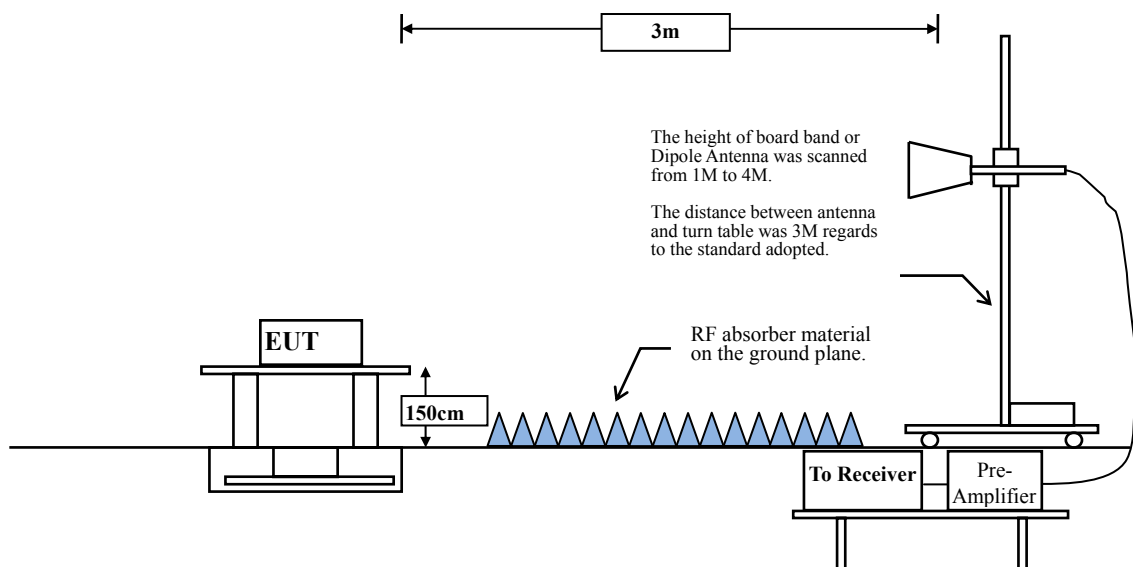

## 6.2. Limit

According to FCC Section 15.247(d). In any 100 kHz bandwidth outside the frequency band in which the spread spectrum or digitally modulated intentional radiator is operating, the radio frequency power that is produced by the intentional radiator shall be at least 20 dB below that in the 100 kHz bandwidth within the band that contains the highest level of the desired power, based on either an RF conducted or measurement, provided the transmitter demonstrates compliance with the peak conducted power limits. If the transmitter complies with the conducted power limits based on the use of RMS averaging over a time interval, the attenuation required under this paragraph shall be 30 dB instead of 20 dB. Attenuation below the general limits specified in Section 15.209(a) is not required. In addition, radiated emissions which fall in the restricted bands, as defined in Section 15.205(a), must also comply with the radiated emission limits specified in Section 15.209(a) (see Section 15.205(c)).

## 6.3. Test Procedure

The EUT was setup according to ANSI C63.10, 2013 and tested according to DTS test procedure of KDB558074 for compliance to FCC 47CFR 15.247 requirements.

The EUT is placed on a turn table which is 1.5 meter above ground. The turn table is rotated 360 degrees to determine the position of the maximum emission level. The EUT was positioned such that the distance from antenna to the EUT was 3 meters.

The antenna is scanned from 1 meter to 4 meters to find out the maximum emission level. This is repeated for both horizontal and vertical polarization of the antenna. In order to find the maximum emission, all of the interface cables were manipulated according to ANSI C63.10:2013 on radiated measurement.

The average measurement tested according to KDB 558074 section 12.2.5.3. Reduced VBW averaging across on- and off-times of the EUT transmissions with max hold.

VBW  $\geq$  1/T:

Duty Cycle	T	1/T	VBW Setting
0.620	0.391	2557	3 kHz

## 6.4. Uncertainty

± 4.08 dB above 1GHz

± 4.22 dB below 1GHz

### 6.5. Test Result of Band Edge

Product : DCM (Data Communication Module)  
 Test Item : Band Edge  
 Test Site : No.3 OATS  
 Test date : 2017/11/14  
 Test Mode : Mode 1: Transmit - BLE (GFSK)

#### RF Radiated Measurement (Horizontal):

Channel No.	Frequency (MHz)	Correct Factor (dB)	Reading Level (dBμV)	Emission Level (dBμV/m)	Peak Limit (dBμV/m)	Average Limit (dBμV/m)	Result
00 (Peak)	2390.000	-2.687	54.971	52.284	74.00	54.00	Pass
00 (Peak)	2400.000	-2.660	70.495	67.835	--	--	--
00 (Peak)	2402.200	-2.657	104.324	101.667	--	--	--
00 (Average)	2390.000	-2.687	45.392	42.705	74.00	54.00	Pass
00 (Average)	2400.000	-2.660	62.312	59.652	--	--	--
00 (Average)	2402.100	-2.657	103.650	100.993	--	--	--

Figure Channel 00: Horizontal (Peak)

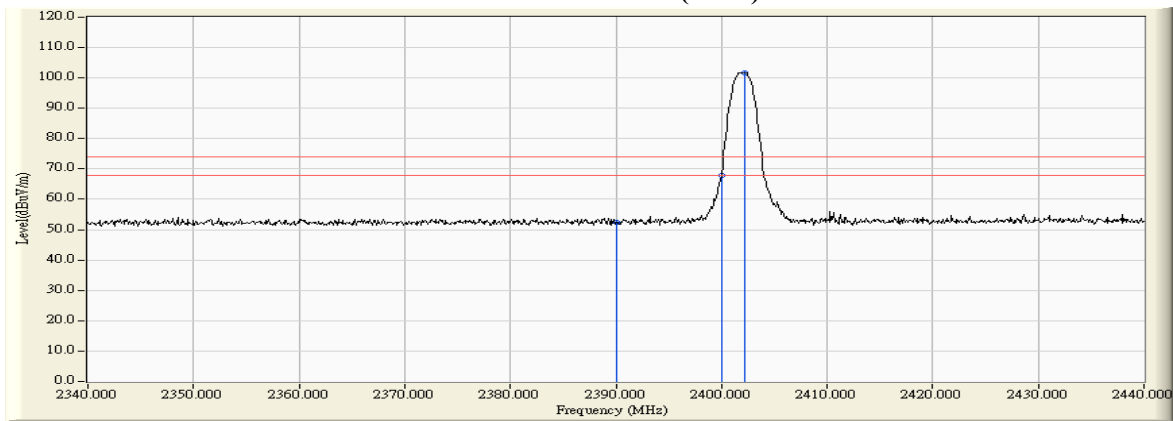
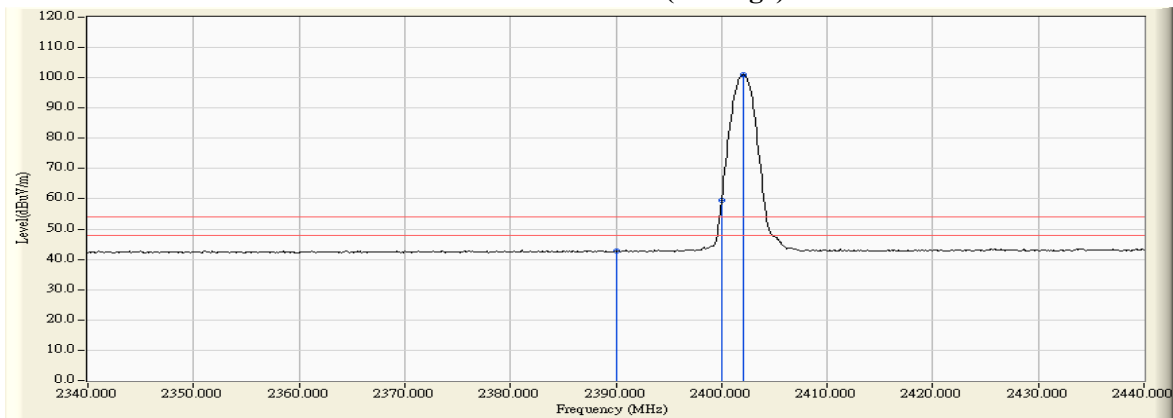

Figure Channel 00: Horizontal (Average)



Note:

1. All readings above 1GHz are performed with peak and/or average measurements as necessary.
2. Peak measurements: RBW = 1MHz, VBW = 3 MHz, Sweep: Auto.
3. Average measurements: RBW = 1MHz, VBW = 3 kHz, Sweep: Auto.
4. “ \* ”, means this data is the worst emission level.
5. Measurement Level = Reading Level + Correct Factor.
6. The average measurement was not performed when the peak measured data under the limit of average detection.

Product : DCM (Data Communication Module)  
 Test Item : Band Edge  
 Test Site : No.3 OATS  
 Test date : 2017/11/14  
 Test Mode : Mode 1: Transmit - BLE (GFSK)

**RF Radiated Measurement (Vertical):**

Channel No.	Frequency (MHz)	Correct Factor (dB)	Reading Level (dBμV)	Emission Level (dBμV/m)	Peak Limit (dBμV/m)	Average Limit (dBμV/m)	Result
00 (Peak)	2390.000	-4.159	55.489	51.330	74.00	54.00	Pass
00 (Peak)	2400.000	-4.171	69.593	65.422	--	--	--
00 (Peak)	2401.800	-4.171	103.413	99.242	--	--	--
00 (Average)	2390.000	-4.159	45.460	41.301	74.00	54.00	Pass
00 (Average)	2400.000	-4.171	61.525	57.354	--	--	--
00 (Average)	2402.000	-4.171	102.743	98.572	--	--	--

**Figure Channel 00: Vertical (Peak)**

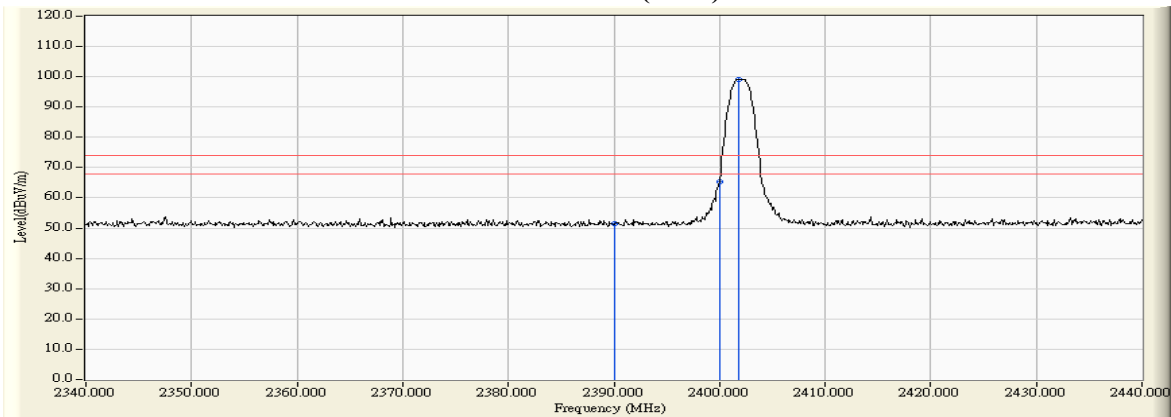

**Figure Channel 00: Vertical (Average)**

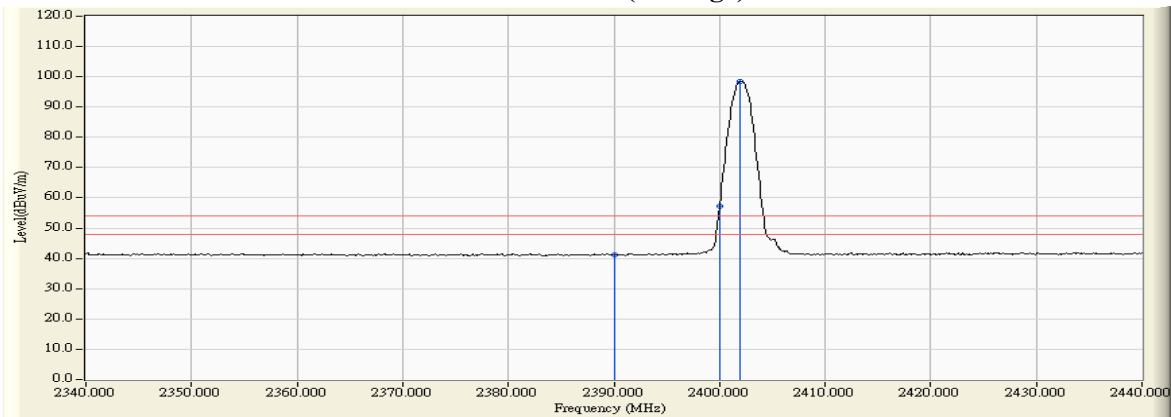

Note:

1. All readings above 1GHz are performed with peak and/or average measurements as necessary.
2. Peak measurements: RBW = 1MHz, VBW = 3 MHz, Sweep: Auto.
3. Average measurements: RBW = 1MHz, VBW = 3 kHz, Sweep: Auto.
4. “ \* ”, means this data is the worst emission level.
5. Measurement Level = Reading Level + Correct Factor.
6. The average measurement was not performed when the peak measured data under the limit of average detection.

Product : DCM (Data Communication Module)  
 Test Item : Band Edge  
 Test Site : No.3 OATS  
 Test date : 2017/11/14  
 Test Mode : Mode 1: Transmit - BLE (GFSK)

**RF Radiated Measurement (Horizontal):**

Channel No.	Frequency (MHz)	Correct Factor (dB)	Reading Level (dBμV)	Emission Level (dBμV/m)	Peak Limit (dBμV/m)	Average Limit (dBμV/m)	Result
39 (Peak)	2479.800	-2.605	100.257	97.652	--	--	--
39 (Peak)	2483.500	-2.601	57.583	54.981	74.00	54.00	Pass
39 (Average)	2480.000	-2.605	99.488	96.883	--	--	--
39 (Average)	2483.500	-2.601	47.195	44.593	74.00	54.00	Pass

**Figure Channel 39: Horizontal (Peak)**

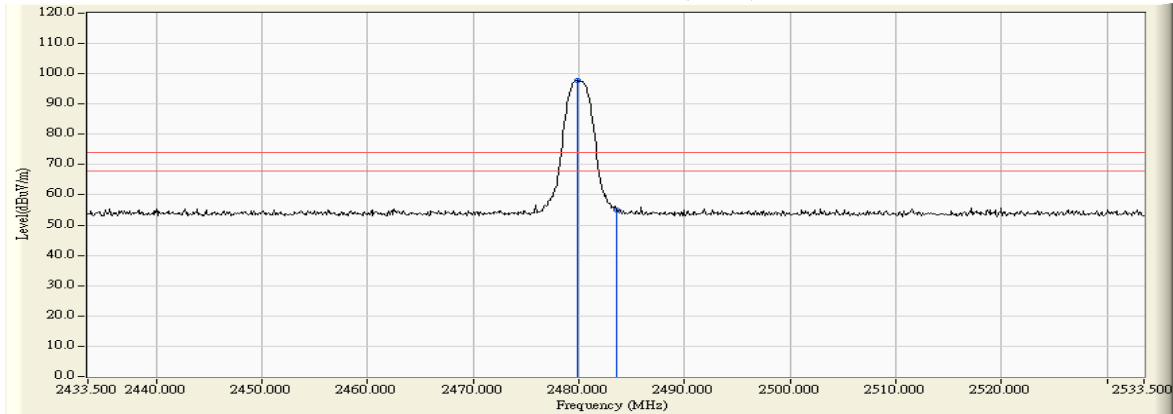

**Figure Channel 39: Horizontal (Average)**

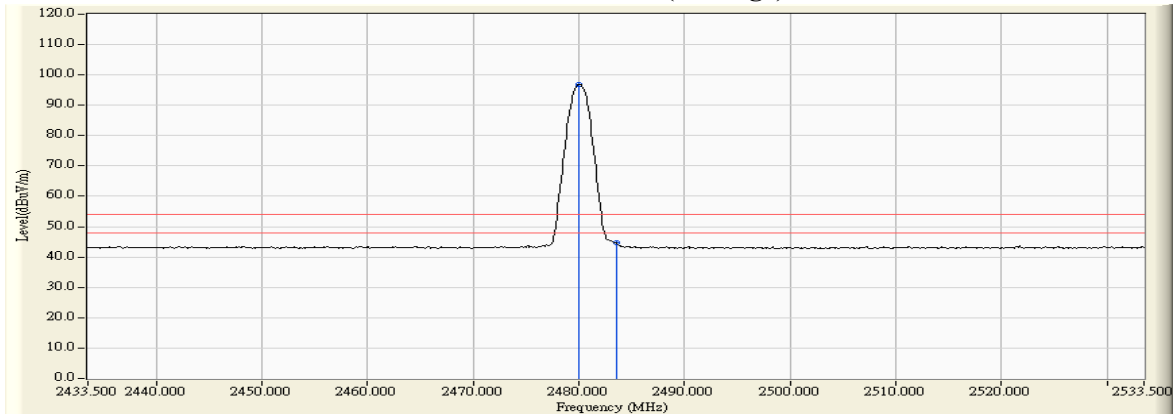

Note:

1. All readings above 1GHz are performed with peak and/or average measurements as necessary.
2. Peak measurements: RBW = 1MHz, VBW = 3 MHz, Sweep: Auto.
3. Average measurements: RBW = 1MHz, VBW = 3 kHz, Sweep: Auto.
4. “ \* ”, means this data is the worst emission level.
5. Measurement Level = Reading Level + Correct Factor.
6. The average measurement was not performed when the peak measured data under the limit of average detection.

Product : DCM (Data Communication Module)  
 Test Item : Band Edge  
 Test Site : No.3 OATS  
 Test date : 2017/11/14  
 Test Mode : Mode 1: Transmit - BLE (GFSK)

**RF Radiated Measurement (Vertical):**

Channel No.	Frequency (MHz)	Correct Factor (dB)	Reading Level (dBμV)	Emission Level (dBμV/m)	Peak Limit (dBμV/m)	Average Limit (dBμV/m)	Result
39 (Peak)	2479.800	-3.978	99.569	95.591	--	--	--
39 (Peak)	2483.500	-3.966	57.321	53.354	74.00	54.00	Pass
39 (Average)	2480.000	-3.978	98.803	94.825	--	--	--
39 (Average)	2483.500	-3.966	46.687	42.720	74.00	54.00	Pass

**Figure Channel 39: Vertical (Peak)**

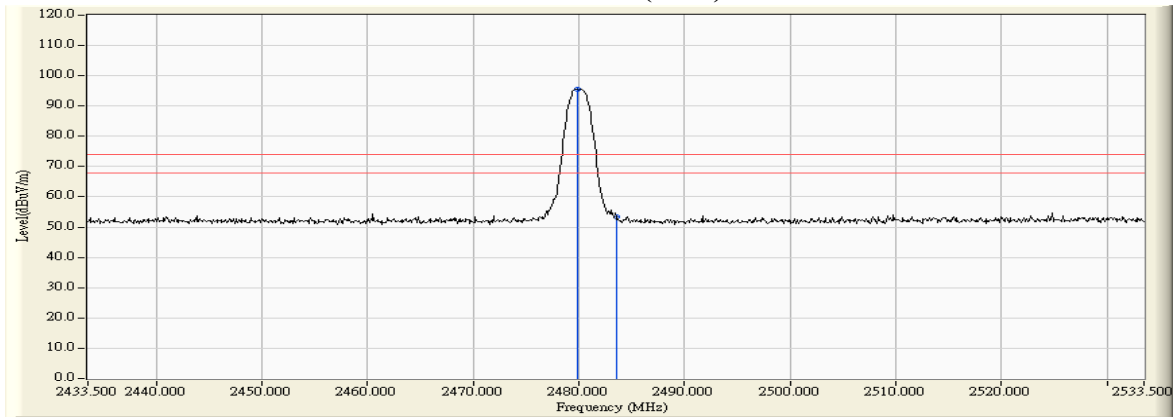

**Figure Channel 39: Vertical (Average)**

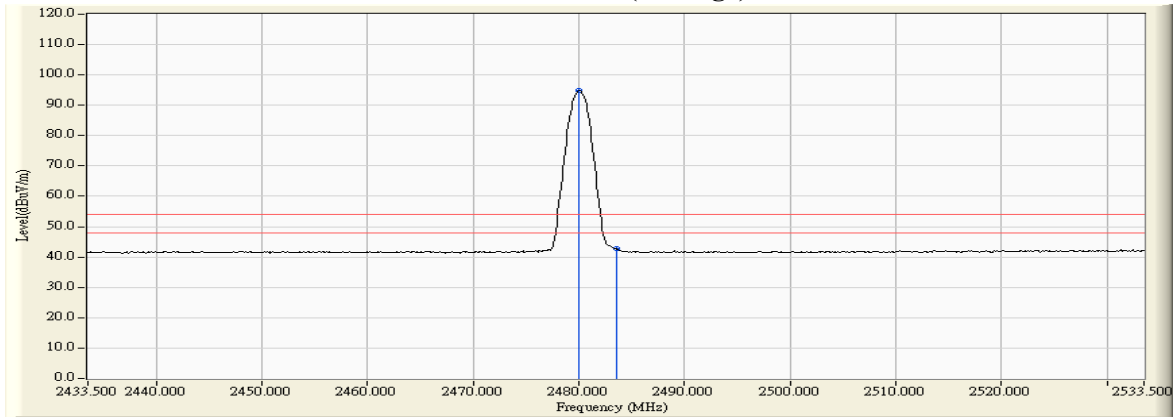

Note:

1. All readings above 1GHz are performed with peak and/or average measurements as necessary.
2. Peak measurements: RBW = 1MHz, VBW = 3 MHz, Sweep: Auto.
3. Average measurements: RBW = 1MHz, VBW = 3 kHz, Sweep: Auto.
4. “ \* ”, means this data is the worst emission level.
5. Measurement Level = Reading Level + Correct Factor.
6. The average measurement was not performed when the peak measured data under the limit of average detection.

## 7. 6dB Bandwidth

### 7.1. Test Setup

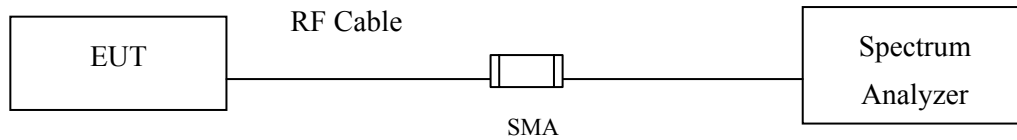

### 7.2. Limits

The minimum bandwidth shall be at least 500 kHz.

### 7.3. Test Procedure

The EUT was setup according to ANSI C63.10 2013; tested according to DTS test procedure of KDB558074 for compliance to FCC 47CFR 15.247 requirements.

Set RBW = 1-5% of the emission bandwidth,  $VBW \geq 3 * RBW$

### 7.4. Uncertainty

$\pm 283\text{Hz}$



### 7.5. Test Result of 6dB Bandwidth

Product : DCM (Data Communication Module)  
 Test Item : 6dB Bandwidth Data  
 Test Site : No.3 OATS  
 Test Mode : Mode 1: Transmit - BLE (GFSK) (2402MHz)

Channel No.	Frequency (MHz)	Measurement Level (kHz)	Required Limit (kHz)	Result
00	2402	740	>500	Pass

Figure Channel 00:

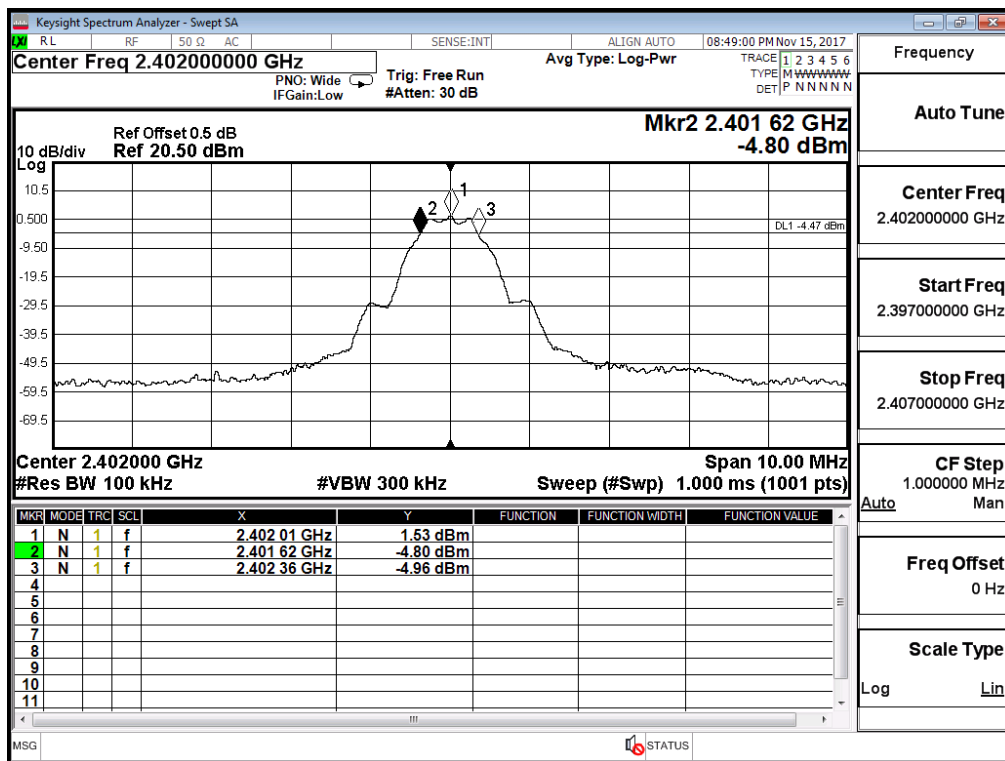

Product : DCM (Data Communication Module)  
 Test Item : 6dB Bandwidth Data  
 Test Site : No.3 OATS  
 Test Mode : Mode 1: Transmit - BLE (GFSK) (2440MHz)

Channel No.	Frequency (MHz)	Measurement Level (kHz)	Required Limit (kHz)	Result
19	2440	740	>500	Pass

Figure Channel 19:

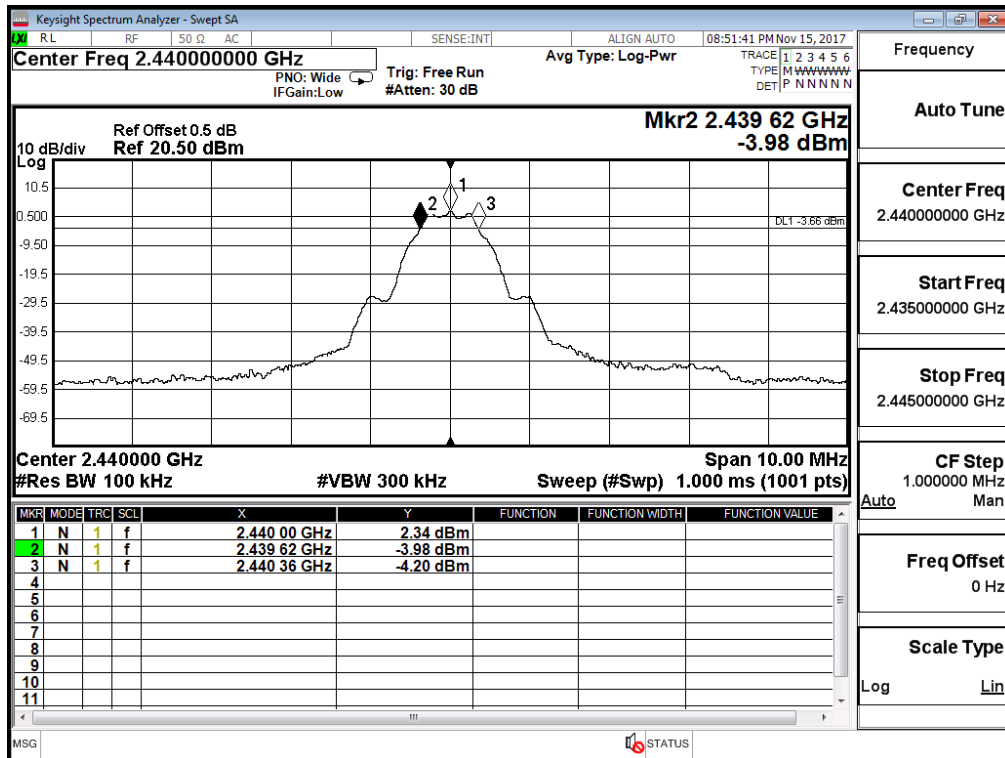

Product : DCM (Data Communication Module)  
 Test Item : 6dB Bandwidth Data  
 Test Site : No.3 OATS  
 Test Mode : Mode 1: Transmit - BLE (GFSK) (2480MHz)

Channel No.	Frequency (MHz)	Measurement Level (kHz)	Required Limit (kHz)	Result
39	2480	7430	>500	Pass

Figure Channel 39:

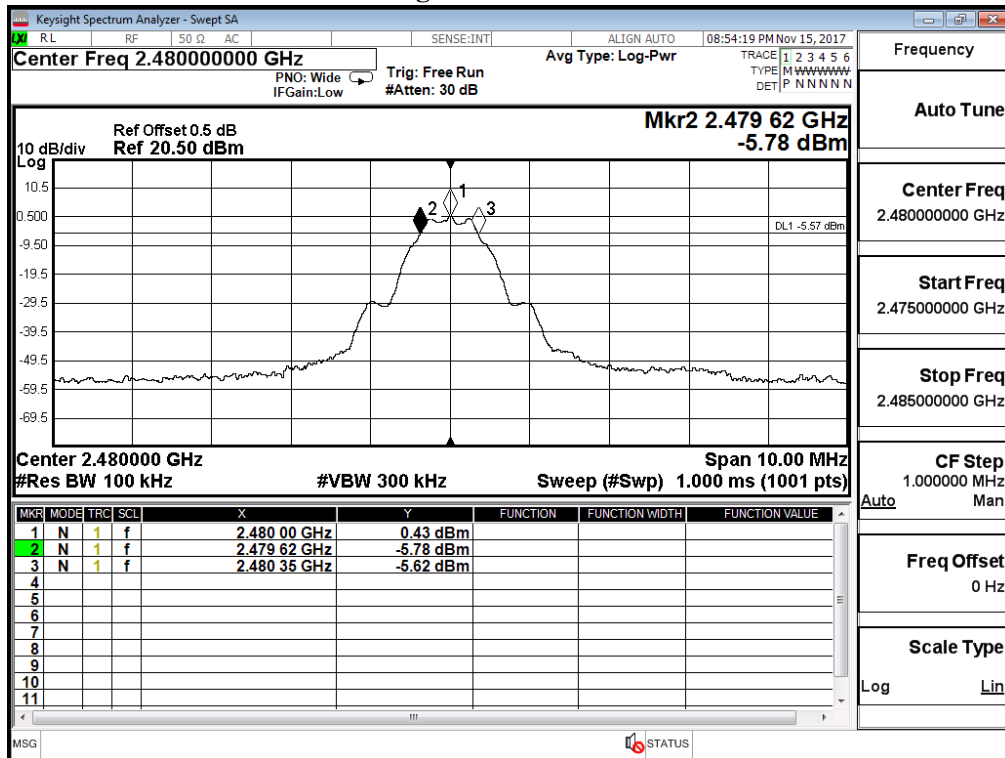

## 8. Power Density

### 8.1. Test Setup

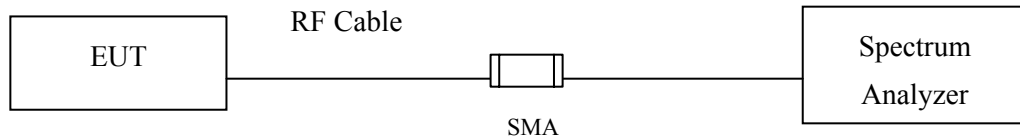

### 8.2. Limits

The transmitted power density averaged over any 1 second interval shall not be greater +8dBm in any 3kHz bandwidth.

### 8.3. Test Procedure

The EUT was setup according to ANSI C63.10: 2013, the maximum power spectral density using KDB 558074 section 10.2 PKPSD (peak PSD) method.

### 8.4. Uncertainty

$\pm 1.20$  dB

### 8.5. Test Result of Power Density

Product : DCM (Data Communication Module)  
 Test Item : Power Density Data  
 Test Site : No.3 OATS  
 Test Mode : Mode 1: Transmit - BLE (GFSK) (2402MHz)

Channel No.	Frequency (MHz)	Measure Level (dBm)	Limit (dBm)	Result
00	2402	1.29	≤ 8dBm	Pass

Figure Channel 00:

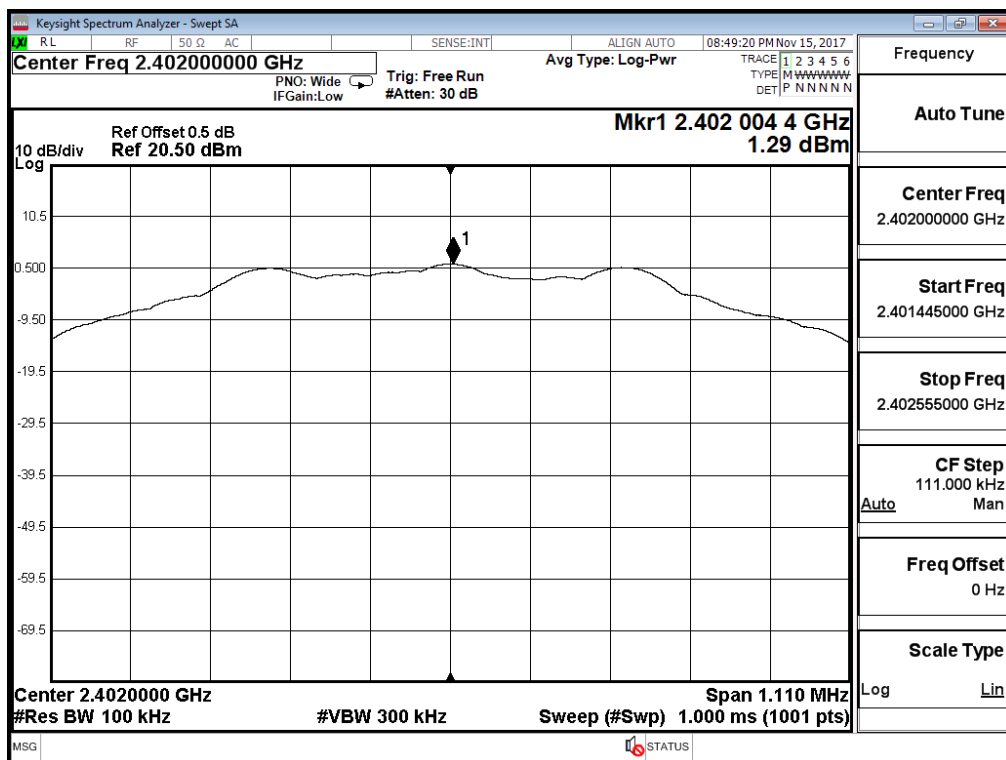

Product : DCM (Data Communication Module)  
 Test Item : Power Density Data  
 Test Site : No.3OATS  
 Test Mode : Mode 1: Transmit - BLE (GFSK) (2440MHz)

Channel No.	Frequency (MHz)	Measurement Level (dBm)	Required Limit (dBm)	Result
19	2440	2.10	≤ 8dBm	Pass

Figure Channel 19:

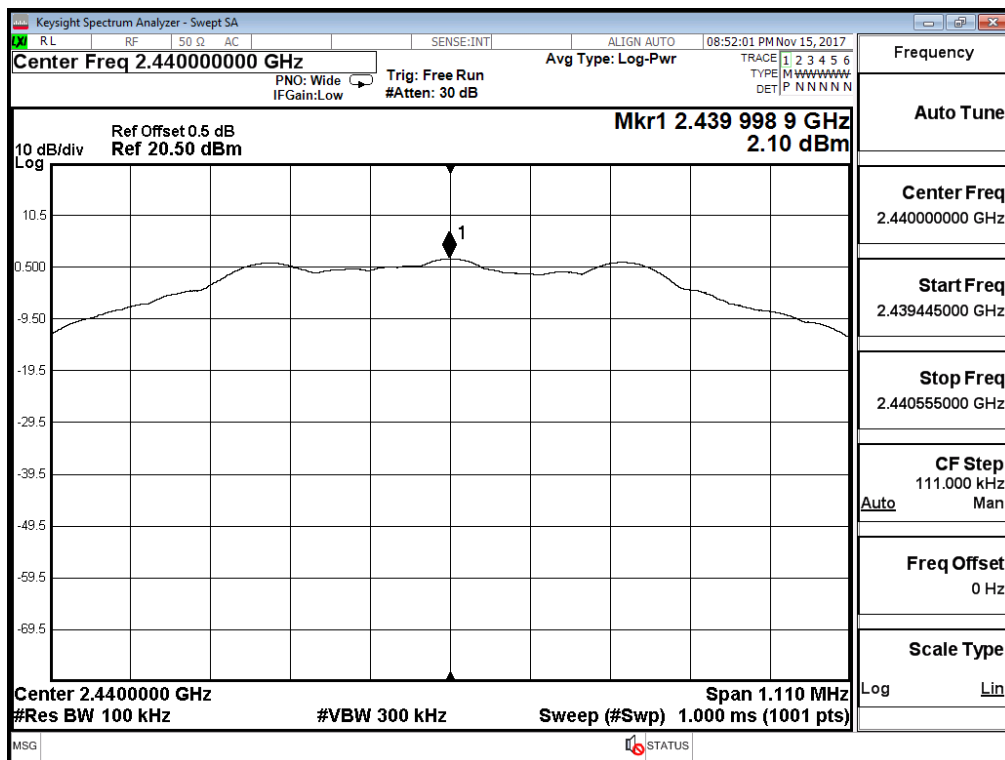

Product : DCM (Data Communication Module)  
 Test Item : Power Density Data  
 Test Site : No.3 OATS  
 Test Mode : Mode 1: Transmit - BLE (GFSK) (2480MHz)

Channel No.	Frequency (MHz)	Measurement Level (dBm)	Required Limit (dBm)	Result
39	2480	0.20	≤ 8dBm	Pass

Figure Channel 39:

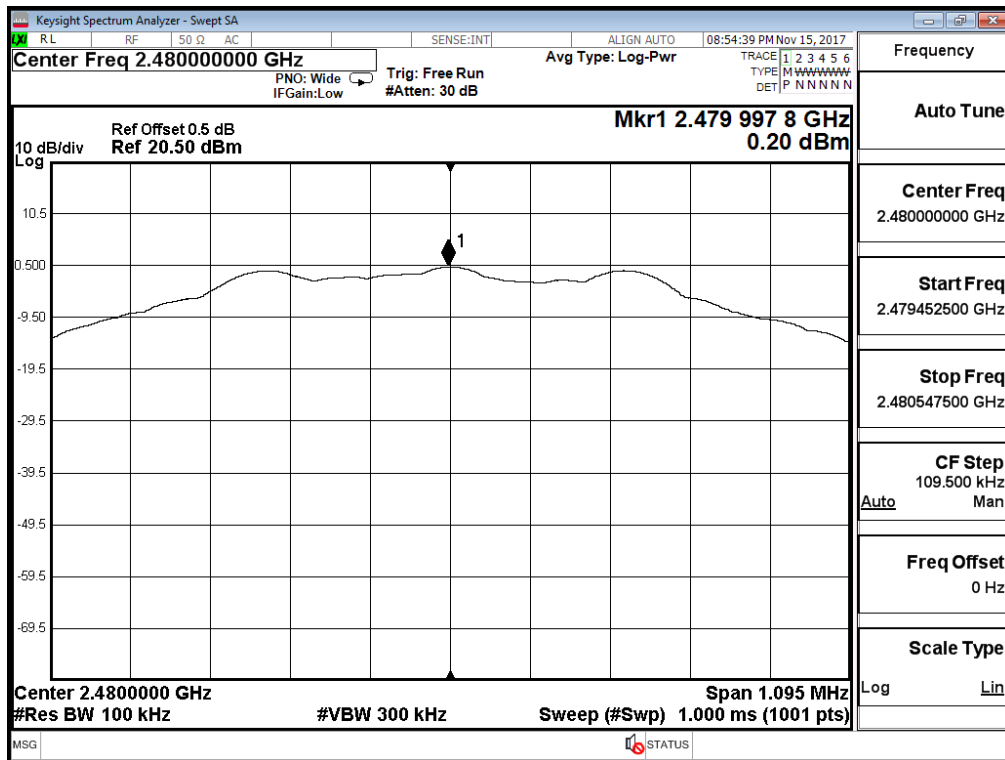

---

**9. EMI Reduction Method During Compliance Testing**

No modification was made during testing.