

Product	DCM (Data Communication Module)		
Test Mode	Spurious Emission (Radiated) - Multi Band Dipole Antenna (STAF)		
Date of Test	2017/11/15	Test Site	Site3
Test Condition	Band 2 (1.4M) CH18607 (1850.7MHz)	Test Range	9kHz ~20GHz

Frequency	Reading Level	Signal Generator Level	Cable Loss	Antenna Gain	EIRP Value	Limit
(GHz)	(dBm)	(dBm)	(dB)	(dBi)	(dBm)	(dBm)

Horizontal Emissions Band 2 (1.4M) QPSK(3,3)

3701	-59.928	-60.540	2.530	12.600	-50.470	-13
5552	-63.363	-59.979	3.050	13.100	-49.929	-13
7403	-63.430	-48.748	3.650	11.500	-40.898	-13
9254	-63.119	-48.288	3.850	12.000	-40.138	-13
11104	-64.222	-46.673	4.580	12.000	-39.253	-13

Vertical Emissions Band 2 (1.4M) QPSK(3,3)

3701	-60.808	-59.173	2.530	12.600	-49.103	-13
5552	-62.580	-58.594	3.050	13.100	-48.544	-13
7403	-63.757	-48.676	3.650	11.500	-40.826	-13
9254	-63.324	-47.904	3.850	12.000	-39.754	-13
11104	-64.001	-46.250	4.580	12.000	-38.830	-13

Note:

1. Receiver setting (Peak Detector) : RBW:1MHz; VBW:3MHz
2. EIRP Value = Signal Generator Level + Antenna Gain - Cable Loss
3. Spurious emissions past 12 GHz are not shown, due to the magnitude of spurious emissions attenuated more than 20 dB below the limit.

Product	DCM (Data Communication Module)		
Test Mode	Spurious Emission (Radiated) - Multi Band Dipole Antenna (STAF)		
Date of Test	2017/11/15	Test Site	Site3
Test Condition	Band 2 (3M) CH18900 (1880MHz)	Test Range	9kHz ~20GHz

Frequency	Reading Level	Signal Generator Level	Cable Loss	Antenna Gain	EIRP Value	Limit
(GHz)	(dBm)	(dBm)	(dB)	(dBi)	(dBm)	(dBm)

Horizontal Emissions Band 2 (3M) QPSK(1,7)

3760	-59.626	-59.973	2.530	12.600	-49.903	-13
5640	-62.509	-59.828	3.050	13.100	-49.778	-13
7520	-64.236	-49.867	3.650	11.500	-42.017	-13
9400	-64.323	-49.005	3.850	12.000	-40.855	-13
11280	-65.076	-48.615	4.580	12.000	-41.195	-13

Vertical Emissions Band 2 (3M) QPSK(1,7)

3760	-59.137	-57.155	2.530	12.600	-47.085	-13
5640	-61.497	-58.347	3.050	13.100	-48.297	-13
7520	-63.894	-48.912	3.650	11.500	-41.062	-13
9400	-64.240	-48.409	3.850	12.000	-40.259	-13
11280	-64.726	-48.072	4.580	12.000	-40.652	-13

Note:

1. Receiver setting (Peak Detector) : RBW:1MHz; VBW:3MHz
2. EIRP Value = Signal Generator Level + Antenna Gain - Cable Loss
3. Spurious emissions past 12 GHz are not shown, due to the magnitude of spurious emissions attenuated more than 20 dB below the limit.

Product	DCM (Data Communication Module)		
Test Mode	Spurious Emission (Radiated) - Multi Band Dipole Antenna (STAF)		
Date of Test	2017/11/15	Test Site	Site3
Test Condition	Band 2 (5M) CH18900 (1880MHz)	Test Range	9kHz ~20GHz

Frequency	Reading Level	Signal Generator Level	Cable Loss	Antenna Gain	EIRP Value	Limit
(GHz)	(dBm)	(dBm)	(dB)	(dBi)	(dBm)	(dBm)

Horizontal Emissions Band 2 (5M) QPSK(1,12)

3760	-59.272	-59.620	2.530	12.600	-49.550	-13
5640	-62.282	-59.601	3.050	13.100	-49.551	-13
7520	-64.107	-49.739	3.650	11.500	-41.889	-13
9400	-63.693	-48.375	3.850	12.000	-40.225	-13
11280	-65.008	-48.547	4.580	12.000	-41.127	-13

Vertical Emissions Band 2 (5M) QPSK(1,12)

3760	-59.236	-57.254	2.530	12.600	-47.184	-13
5640	-59.887	-56.738	3.050	13.100	-46.688	-13
7520	-64.195	-49.213	3.650	11.500	-41.363	-13
9400	-63.250	-47.419	3.850	12.000	-39.269	-13
11280	-65.176	-48.522	4.580	12.000	-41.102	-13

Note:

1. Receiver setting (Peak Detector) : RBW:3MHz; VBW:3MHz
2. EIRP Value = Signal Generator Level + Antenna Gain - Cable Loss
3. Spurious emissions past 12 GHz are not shown, due to the magnitude of spurious emissions attenuated more than 20 dB below the limit.

Product	DCM (Data Communication Module)		
Test Mode	Spurious Emission (Radiated) - Multi Band Dipole Antenna (STAF)		
Date of Test	2017/11/15	Test Site	Site3
Test Condition	Band 2 (10M) CH18650 (1855MHz)	Test Range	9kHz ~20GHz

Frequency	Reading Level	Signal Generator Level	Cable Loss	Antenna Gain	EIRP Value	Limit
(GHz)	(dBm)	(dBm)	(dB)	(dBi)	(dBm)	(dBm)

Horizontal Emissions Band 2 (10M) QPSK(1,24)

3710	-59.577	-60.188	2.530	12.600	-50.118	-13
5565	-62.585	-59.281	3.050	13.100	-49.231	-13
7420	-63.314	-48.715	3.650	11.500	-40.865	-13
9275	-62.802	-47.845	3.850	12.000	-39.695	-13
11130	-64.656	-47.224	4.580	12.000	-39.804	-13

Vertical Emissions Band 2 (10M) QPSK(1,24)

3710	-59.512	-57.877	2.530	12.600	-47.807	-13
5565	-61.778	-57.851	3.050	13.100	-47.801	-13
7420	-63.544	-48.460	3.650	11.500	-40.610	-13
9275	-63.142	-47.614	3.850	12.000	-39.464	-13
11130	-63.888	-46.226	4.580	12.000	-38.806	-13

Note:

1. Receiver setting (Peak Detector) : RBW:1MHz; VBW:3MHz
2. ERP Value = Signal Generator Level + Antenna Gain - Cable Loss
3. Spurious emissions past 12 GHz are not shown, due to the magnitude of spurious emissions attenuated more than 20 dB below the limit.

Product	DCM (Data Communication Module)		
Test Mode	Spurious Emission (Radiated) - Multi Band Dipole Antenna (STAF)		
Date of Test	2017/11/15	Test Site	Site3
Test Condition	Band 2 (15M) CH18675 (1857.5MHz)	Test Range	9kHz ~20GHz

Frequency	Reading Level	Signal Generator Level	Cable Loss	Antenna Gain	EIRP Value	Limit
(GHz)	(dBm)	(dBm)	(dB)	(dBi)	(dBm)	(dBm)

Horizontal Emissions Band 2 (15M) QPSK(1,0)

3715	-59.852	-60.426	2.530	12.600	-50.356	-13
5573	-62.565	-59.261	3.050	13.100	-49.211	-13
7430	-63.292	-48.722	3.650	11.500	-40.872	-13
9288	-62.415	-47.381	3.850	12.000	-39.231	-13
11145	-65.087	-47.773	4.580	12.000	-40.353	-13

Vertical Emissions Band 2 (15M) QPSK(1,0)

3715	-59.238	-57.625	2.530	12.600	-47.555	-13
5573	-62.518	-58.651	3.050	13.100	-48.601	-13
7430	-63.963	-48.883	3.650	11.500	-41.033	-13
9288	-62.852	-47.216	3.850	12.000	-39.066	-13
11145	-64.438	-46.974	4.580	12.000	-39.554	-13

Note:

1. Receiver setting (Peak Detector) : RBW:1MHz; VBW:3MHz
2. EIRP Value = Signal Generator Level + Antenna Gain - Cable Loss
3. Spurious emissions past 12 GHz are not shown, due to the magnitude of spurious emissions attenuated more than 20 dB below the limit.

Product	DCM (Data Communication Module)		
Test Mode	Spurious Emission (Radiated) - Multi Band Dipole Antenna (STAF)		
Date of Test	2017/11/15	Test Site	Site3
Test Condition	Band 2 (20M) CH18700 (1860MHz)	Test Range	9kHz ~20GHz

Frequency	Reading Level	Signal Generator Level	Cable Loss	Antenna Gain	EIRP Value	Limit
(GHz)	(dBm)	(dBm)	(dB)	(dBi)	(dBm)	(dBm)

Horizontal Emissions Band 2 (20M) QPSK(1,49)

3720	-59.625	-60.199	2.530	12.600	-50.129	-13
5580	-62.658	-59.513	3.050	13.100	-49.463	-13
7440	-63.182	-48.583	3.650	11.500	-40.733	-13
9300	-62.274	-47.239	3.850	12.000	-39.089	-13
11160	-64.896	-47.701	4.580	12.000	-40.281	-13

Vertical Emissions Band 2 (20M) QPSK(1,49)

3720	-59.570	-57.885	2.530	12.600	-47.815	-13
5580	-62.405	-58.597	3.050	13.100	-48.547	-13
7440	-63.784	-48.706	3.650	11.500	-40.856	-13
9300	-62.869	-47.191	3.850	12.000	-39.041	-13
11160	-64.090	-46.830	4.580	12.000	-39.410	-13

Note:

1. Receiver setting (Peak Detector) : RBW:1MHz; VBW:3MHz
2. EIRP Value = Signal Generator Level + Antenna Gain - Cable Loss
3. Spurious emissions past 12 GHz are not shown, due to the magnitude of spurious emissions attenuated more than 20 dB below the limit.

Product	DCM (Data Communication Module)		
Test Mode	Spurious Emission (Radiated) - Multi Band Dipole Antenna (STAF)		
Date of Test	2017/11/15	Test Site	Site3
Test Condition	Band 4 (1.4M) CH20175 (1732.5MHz)	Test Range	9kHz ~20GHz

Frequency	Reading Level	Signal Generator Level	Cable Loss	Antenna Gain	EIRP Value	Limit
(GHz)	(dBm)	(dBm)	(dB)	(dBi)	(dBm)	(dBm)

Horizontal Emissions Band 4 (1.4M) QPSK(3,3)

3465	-60.451	-61.245	2.530	12.600	-51.175	-13
5198	-57.414	-53.376	3.050	13.100	-43.326	-13
6930	-63.821	-51.962	3.650	11.500	-44.112	-13
8663	-63.265	-47.773	3.850	12.000	-39.623	-13
10395	-60.674	-43.932	4.580	12.000	-36.512	-13
12128	-65.200	-48.098	4.800	13.300	-39.598	-13

Vertical Emissions Band 4 (1.4M) QPSK(3,3)

3465	-59.642	-59.543	2.530	12.600	-49.473	-13
5198	-50.059	-45.697	3.050	13.100	-35.647	-13
6930	-62.977	-50.614	3.650	11.500	-42.764	-13
8663	-63.868	-47.864	3.850	12.000	-39.714	-13
10395	-61.566	-44.667	4.580	12.000	-37.247	-13
12128	-65.138	-48.156	4.800	13.300	-39.656	-13

Note:

1. Receiver setting (Peak Detector) : RBW:1MHz; VBW:3MHz
2. EIRP Value = Signal Generator Level + Antenna Gain - Cable Loss
3. Spurious emissions past 13 GHz are not shown, due to the magnitude of spurious emissions attenuated more than 20 dB below the limit.

Product	DCM (Data Communication Module)		
Test Mode	Spurious Emission (Radiated) - Multi Band Dipole Antenna (STAF)		
Date of Test	2017/11/15	Test Site	Site3
Test Condition	Band 4 (3M) CH20385 (1753.5MHz)	Test Range	9kHz ~20GHz

Frequency	Reading Level	Signal Generator Level	Cable Loss	Antenna Gain	EIRP Value	Limit
(GHz)	(dBm)	(dBm)	(dB)	(dBi)	(dBm)	(dBm)

Horizontal Emissions Band 4 (3M) QPSK(1,0)

3507	-60.089	-60.676	2.530	12.600	-50.606	-13
5261	-62.308	-58.147	3.050	13.100	-48.097	-13
7014	-63.886	-50.962	3.650	11.500	-43.112	-13
8768	-63.756	-47.407	3.850	12.000	-39.257	-13
10521	-61.561	-45.190	4.580	12.000	-37.770	-13
12275	-64.949	-47.133	4.800	13.300	-38.633	-13

Vertical Emissions Band 4 (3M) QPSK(1,0)

3507	-57.224	-56.752	2.530	12.600	-46.682	-13
5261	-50.410	-45.870	3.050	13.100	-35.820	-13
7014	-62.638	-49.089	3.650	11.500	-41.239	-13
8768	-64.304	-47.409	3.850	12.000	-39.259	-13
10521	-62.312	-45.924	4.580	12.000	-38.504	-13
12275	-65.504	-47.745	4.800	13.300	-39.245	-13

Note:

1. Receiver setting (Peak Detector) : RBW:1MHz; VBW:3MHz
2. EIRP Value = Signal Generator Level + Antenna Gain - Cable Loss
3. Spurious emissions past 13 GHz are not shown, due to the magnitude of spurious emissions attenuated more than 20 dB below the limit.

Product	DCM (Data Communication Module)		
Test Mode	Spurious Emission (Radiated) - Multi Band Dipole Antenna (STAF)		
Date of Test	2017/11/15	Test Site	Site3
Test Condition	Band 4 (5M) CH20375 (1752.5MHz)	Test Range	9kHz ~20GHz

Frequency	Reading Level	Signal Generator Level	Cable Loss	Antenna Gain	EIRP Value	Limit
(GHz)	(dBm)	(dBm)	(dB)	(dBi)	(dBm)	(dBm)

Horizontal Emissions Band 4 (5M) QPSK(1,12)

3505	-59.617	-60.204	2.530	12.600	-50.134	-13
5258	-61.683	-57.522	3.050	13.100	-47.472	-13
7010	-63.248	-50.479	3.650	11.500	-42.629	-13
8763	-63.697	-47.273	3.850	12.000	-39.123	-13
10515	-62.811	-46.440	4.580	12.000	-39.020	-13
12268	-65.126	-47.311	4.800	13.300	-38.811	-13

Vertical Emissions Band 4 (5M) QPSK(1,12)

3505	-56.934	-56.462	2.530	12.600	-46.392	-13
5258	-50.580	-46.040	3.050	13.100	-35.990	-13
7010	-63.579	-49.971	3.650	11.500	-42.121	-13
8763	-63.993	-47.202	3.850	12.000	-39.052	-13
10515	-62.636	-46.256	4.580	12.000	-38.836	-13
12268	-64.937	-47.177	4.800	13.300	-38.677	-13

Note:

1. Receiver setting (Peak Detector) : RBW:1MHz; VBW:3MHz
2. EIRP Value = Signal Generator Level + Antenna Gain - Cable Loss
3. Spurious emissions past 13 GHz are not shown, due to the magnitude of spurious emissions attenuated more than 20 dB below the limit.

Product	DCM (Data Communication Module)		
Test Mode	Spurious Emission (Radiated) - Multi Band Dipole Antenna (STAF)		
Date of Test	2017/11/15	Test Site	Site3
Test Condition	Band 4 (10M) CH20350 (1750MHz)	Test Range	9kHz ~20GHz

Frequency	Reading Level	Signal Generator Level	Cable Loss	Antenna Gain	EIRP Value	Limit
(GHz)	(dBm)	(dBm)	(dB)	(dBi)	(dBm)	(dBm)

Horizontal Emissions Band 4 (10M) QPSK(1,24)

3500	-59.374	-59.961	2.530	12.600	-49.891	-13
5250	-58.499	-54.338	3.050	13.100	-44.288	-13
7000	-62.905	-50.136	3.650	11.500	-42.286	-13
8750	-63.827	-47.661	3.850	12.000	-39.511	-13
10500	-62.178	-45.811	4.580	12.000	-38.391	-13
12250	-65.312	-47.627	4.800	13.300	-39.127	-13

Vertical Emissions Band 4 (10M) QPSK(1,24)

3500	-57.101	-56.629	2.530	12.600	-46.559	-13
5250	-49.892	-45.352	3.050	13.100	-35.302	-13
7000	-63.962	-50.414	3.650	11.500	-42.564	-13
8750	-63.649	-46.960	3.850	12.000	-38.810	-13
10500	-61.998	-45.611	4.580	12.000	-38.191	-13
12250	-65.077	-47.472	4.800	13.300	-38.972	-13

Note:

1. Receiver setting (Peak Detector) : RBW:1MHz; VBW:3MHz
2. EIRP Value = Signal Generator Level + Antenna Gain - Cable Loss
3. Spurious emissions past 13 GHz are not shown, due to the magnitude of spurious emissions attenuated more than 20 dB below the limit.

Product	DCM (Data Communication Module)		
Test Mode	Spurious Emission (Radiated) - Multi Band Dipole Antenna (STAF)		
Date of Test	2017/11/15	Test Site	Site3
Test Condition	Band 4 (15M) CH20325 (1747.5MHz)	Test Range	9kHz ~20GHz

Frequency	Reading Level	Signal Generator Level	Cable Loss	Antenna Gain	EIRP Value	Limit
(GHz)	(dBm)	(dBm)	(dB)	(dBi)	(dBm)	(dBm)

Horizontal Emissions Band 4 (15M) QPSK(1,37)

3495	-60.677	-61.260	2.530	12.600	-51.190	-13
5243	-61.143	-57.003	3.050	13.100	-46.953	-13
6990	-61.869	-49.545	3.650	11.500	-41.695	-13
8738	-63.419	-47.344	3.850	12.000	-39.194	-13
10485	-62.657	-46.276	4.580	12.000	-38.856	-13
12233	-65.297	-47.742	4.800	13.300	-39.242	-13

Vertical Emissions Band 4 (15M) QPSK(1,37)

3495	-58.654	-58.261	2.530	12.600	-48.191	-13
5243	-50.263	-45.765	3.050	13.100	-35.715	-13
6990	-63.429	-50.045	3.650	11.500	-42.195	-13
8738	-63.743	-47.155	3.850	12.000	-39.005	-13
10485	-62.110	-45.616	4.580	12.000	-38.196	-13
12233	-64.834	-47.383	4.800	13.300	-38.883	-13

Note:

1. Receiver setting (Peak Detector) : RBW:1MHz; VBW:3MHz
2. EIRP Value = Signal Generator Level + Antenna Gain - Cable Loss
3. Spurious emissions past 13 GHz are not shown, due to the magnitude of spurious emissions attenuated more than 20 dB below the limit.

Product	DCM (Data Communication Module)		
Test Mode	Spurious Emission (Radiated) - Multi Band Dipole Antenna (STAF)		
Date of Test	2017/11/15	Test Site	Site3
Test Condition	Band 4 (20M) CH20300 (1745MHz)	Test Range	9kHz ~20GHz

Frequency	Reading Level	Signal Generator Level	Cable Loss	Antenna Gain	EIRP Value	Limit
(GHz)	(dBm)	(dBm)	(dB)	(dBi)	(dBm)	(dBm)

Horizontal Emissions Band 4 (20M) QPSK(1,49)

3490	-60.730	-61.312	2.530	12.600	-51.242	-13
5235	-59.661	-55.542	3.050	13.100	-45.492	-13
6980	-63.096	-50.470	3.650	11.500	-42.620	-13
8725	-63.313	-47.422	3.850	12.000	-39.272	-13
10470	-62.439	-46.026	4.580	12.000	-38.606	-13
12215	-65.326	-47.901	4.800	13.300	-39.401	-13

Vertical Emissions Band 4 (20M) QPSK(1,49)

3490	-59.349	-59.029	2.530	12.600	-48.959	-13
5235	-49.645	-45.189	3.050	13.100	-35.139	-13
6980	-63.097	-49.879	3.650	11.500	-42.029	-13
8725	-63.137	-46.753	3.850	12.000	-38.603	-13
10470	-62.358	-45.802	4.580	12.000	-38.382	-13
12215	-64.560	-47.263	4.800	13.300	-38.763	-13

Note:

1. Receiver setting (Peak Detector) : RBW:1MHz; VBW:3MHz
2. EIRP Value = Signal Generator Level + Antenna Gain - Cable Loss
3. Spurious emissions past 13 GHz are not shown, due to the magnitude of spurious emissions attenuated more than 20 dB below the limit.

Product	DCM (Data Communication Module)		
Test Mode	Spurious Emission (Radiated) - Multi Band Dipole Antenna (STAF)		
Date of Test	2017/11/15	Test Site	Site3
Test Condition	Band 5 (1.4M) CH20643 (848.3MHz)	Test Range	9kHz ~10GHz

Frequency	Reading Level	Signal Generator Level	Cable Loss	Antenna Gain	EIRP Value	Limit
(GHz)	(dBm)	(dBm)	(dB)	(dBi)	(dBm)	(dBm)

Horizontal Emissions Band 5 (1.4M) QPSK(3,0)

1697	-54.428	-57.185	1.630	9.800	-49.015	-13
2545	-58.687	-59.491	2.100	10.600	-50.991	-13
3393	-60.943	-62.438	2.350	12.300	-52.488	-13
4242	-59.153	-57.500	2.700	12.600	-47.600	-13
5090	-62.483	-57.917	2.830	12.700	-48.047	-13
5938	-64.481	-60.316	3.200	13.000	-50.516	-13

Vertical Emissions Band 5 (1.4M) QPSK(3,0)

1697	-60.716	-63.049	1.630	9.800	-54.879	-13
2545	-63.995	-63.992	2.100	10.600	-55.492	-13
3393	-60.592	-60.979	2.350	12.300	-51.029	-13
4242	-61.661	-58.847	2.700	12.600	-48.947	-13
5090	-62.733	-57.886	2.830	12.700	-48.016	-13
5938	-63.583	-59.346	3.200	13.000	-49.546	-13

Note:

1. Receiver setting (Peak Detector) : RBW:1MHz; VBW:3MHz
2. EIRP Value = Signal Generator Level + Antenna Gain - Cable Loss
3. Spurious emissions past 6 GHz are not shown, due to the magnitude of spurious emissions attenuated more than 20 dB below the limit.

Product	DCM (Data Communication Module)		
Test Mode	Spurious Emission (Radiated) - Multi Band Dipole Antenna (STAF)		
Date of Test	2017/11/15	Test Site	Site3
Test Condition	Band 5 (3M) CH20525 (836.5MHz)	Test Range	9kHz ~10GHz

Frequency	Reading Level	Signal Generator Level	Cable Loss	Antenna Gain	EIRP Value	Limit
(GHz)	(dBm)	(dBm)	(dB)	(dBi)	(dBm)	(dBm)

Horizontal Emissions Band 5 (3M) QPSK(1,7)

1673	-58.729	-61.770	1.630	9.800	-53.600	-13
2510	-58.005	-58.563	2.100	10.600	-50.063	-13
3346	-60.035	-61.687	2.350	12.300	-51.737	-13
4183	-60.382	-59.586	2.700	12.600	-49.686	-13
5019	-63.209	-58.851	2.830	12.700	-48.981	-13
5856	-63.298	-60.294	3.200	13.000	-50.494	-13

Vertical Emissions Band 5 (3M) QPSK(1,7)

1673	-62.172	-64.882	1.630	9.800	-56.712	-13
2510	-63.401	-63.451	2.100	10.600	-54.951	-13
3346	-59.557	-60.066	2.350	12.300	-50.116	-13
4183	-61.068	-58.658	2.700	12.600	-48.758	-13
5019	-62.999	-58.001	2.830	12.700	-48.131	-13
5856	-64.601	-61.553	3.200	13.000	-51.753	-13

Note:

1. Receiver setting (Peak Detector) : RBW:1MHz; VBW:3MHz
2. EIRP Value = Signal Generator Level + Antenna Gain - Cable Loss
3. Spurious emissions past 6 GHz are not shown, due to the magnitude of spurious emissions attenuated more than 20 dB below the limit.

Product	DCM (Data Communication Module)		
Test Mode	Spurious Emission (Radiated) - Multi Band Dipole Antenna (STAF)		
Date of Test	2017/11/15	Test Site	Site3
Test Condition	Band 5 (5M) CH20625 (846.5MHz)	Test Range	9kHz ~10GHz

Frequency	Reading Level	Signal Generator Level	Cable Loss	Antenna Gain	EIRP Value	Limit
(GHz)	(dBm)	(dBm)	(dB)	(dBi)	(dBm)	(dBm)

Horizontal Emissions Band 5 (5M) QPSK(1,12)

1693	-58.713	-61.533	1.630	9.800	-53.363	-13
2540	-63.204	-64.008	2.100	10.600	-55.508	-13
3386	-61.373	-62.927	2.350	12.300	-52.977	-13
4233	-62.091	-60.623	2.700	12.600	-50.723	-13
5079	-62.502	-57.928	2.830	12.700	-48.058	-13
5926	-63.720	-59.687	3.200	13.000	-49.887	-13

Vertical Emissions Band 5 (5M) QPSK(1,12)

1693	-64.006	-66.433	1.630	9.800	-58.263	-13
2540	-64.814	-64.811	2.100	10.600	-56.311	-13
3386	-59.901	-60.289	2.350	12.300	-50.339	-13
4233	-62.201	-59.463	2.700	12.600	-49.563	-13
5079	-62.322	-57.450	2.830	12.700	-47.580	-13
5926	-63.883	-59.740	3.200	13.000	-49.940	-13

Note:

1. Receiver setting (Peak Detector) : RBW:1MHz; VBW:3MHz
2. EIRP Value = Signal Generator Level + Antenna Gain - Cable Loss
3. Spurious emissions past 6 GHz are not shown, due to the magnitude of spurious emissions attenuated more than 20 dB below the limit.

Product	DCM (Data Communication Module)		
Test Mode	Spurious Emission (Radiated) - Multi Band Dipole Antenna (STAF)		
Date of Test	2017/11/15	Test Site	Site3
Test Condition	Band 5 (10M) CH20600 (844MHz)	Test Range	9kHz ~10GHz

Frequency	Reading Level	Signal Generator Level	Cable Loss	Antenna Gain	EIRP Value	Limit
(GHz)	(dBm)	(dBm)	(dB)	(dBi)	(dBm)	(dBm)

Horizontal Emissions Band 5 (10M) QPSK(1,24)

1688	-58.768	-61.587	1.630	9.800	-53.417	-13
2532	-56.199	-56.904	2.100	10.600	-48.404	-13
3376	-60.837	-62.472	2.350	12.300	-52.522	-13
4220	-62.274	-60.899	2.700	12.600	-50.999	-13
5064	-63.326	-58.800	2.830	12.700	-48.930	-13
5908	-64.488	-60.653	3.200	13.000	-50.853	-13

Vertical Emissions Band 5 (10M) QPSK(1,24)

1688	-62.893	-65.320	1.630	9.800	-57.150	-13
2532	-62.936	-62.951	2.100	10.600	-54.451	-13
3376	-60.909	-61.349	2.350	12.300	-51.399	-13
4220	-62.648	-60.060	2.700	12.600	-50.160	-13
5064	-62.643	-57.732	2.830	12.700	-47.862	-13
5908	-63.211	-59.223	3.200	13.000	-49.423	-13

Note:

1. Receiver setting (Peak Detector) : RBW:1MHz; VBW:3MHz
2. EIRP Value = Signal Generator Level + Antenna Gain - Cable Loss
3. Spurious emissions past 6 GHz are not shown, due to the magnitude of spurious emissions attenuated more than 20 dB below the limit.

Product	DCM (Data Communication Module)		
Test Mode	Spurious Emission (Radiated) - Multi Band Dipole Antenna (STAF)		
Date of Test	2017/11/15	Test Site	Site3
Test Condition	Band 17 (5M) CH23755 (706.5MHz)	Test Range	9KHz ~10GHz

Frequency	Reading Level	Signal Generator Level	Cable Loss	Antenna Gain	EIRP Value	Limit
(GHz)	(dBm)	(dBm)	(dB)	(dBi)	(dBm)	(dBm)

Horizontal Emissions Band 17 (5M) QPSK(1,12)

1413	-63.417	-67.852	1.630	9.800	-59.682	-13
2120	-64.877	-65.428	2.100	10.600	-56.928	-13
2826	-63.552	-65.458	2.350	12.300	-55.508	-13
3533	-60.110	-60.559	2.700	12.600	-50.659	-13
4239	-61.352	-59.483	2.830	12.700	-49.613	-13
4946	-63.078	-58.885	3.200	13.000	-49.085	-13

Vertical Emissions Band 17 (5M) QPSK(1,12)

1413	-64.802	-68.234	1.630	9.800	-60.064	-13
2120	-65.519	-66.127	2.100	10.600	-57.627	-13
2826	-65.042	-65.720	2.350	12.300	-55.770	-13
3533	-59.715	-58.415	2.700	12.600	-48.515	-13
4239	-62.290	-58.916	2.830	12.700	-49.046	-13
4946	-62.504	-57.430	3.200	13.000	-47.630	-13

Note:

1. Receiver setting (Peak Detector) : RBW:1MHz; VBW:3MHz
2. EIRP Value = Signal Generator Level + Antenna Gain - Cable Loss
3. Spurious emissions past 5 GHz are not shown, due to the magnitude of spurious emissions attenuated more than 20 dB below the limit.

Product	DCM (Data Communication Module)		
Test Mode	Spurious Emission (Radiated) - Multi Band Dipole Antenna (STAF)		
Date of Test	2017/11/15	Test Site	Site3
Test Condition	Band 17 (10M) CH23780 (709MHz)	Test Range	9KHz ~10GHz

Frequency	Reading Level	Signal Generator Level	Cable Loss	Antenna Gain	EIRP Value	Limit
(GHz)	(dBm)	(dBm)	(dB)	(dBi)	(dBm)	(dBm)

Horizontal Emissions Band 17 (10M) QPSK(1,0)

1418	-63.998	-68.433	1.630	9.800	-60.263	-13
2127	-64.748	-65.362	2.100	10.600	-56.862	-13
2836	-64.274	-66.093	2.350	12.300	-56.143	-13
3545	-60.243	-60.692	2.700	12.600	-50.792	-13
4254	-61.837	-59.968	2.830	12.700	-50.098	-13
4963	-62.034	-57.859	3.200	13.000	-48.059	-13

Vertical Emissions Band 17 (10M) QPSK(1,0)

1418	-64.088	-67.484	1.630	9.800	-59.314	-13
2127	-64.689	-65.426	2.100	10.600	-56.926	-13
2836	-64.844	-65.363	2.350	12.300	-55.413	-13
3545	-59.473	-58.728	2.700	12.600	-48.828	-13
4254	-62.146	-59.151	2.830	12.700	-49.281	-13
4963	-62.843	-57.938	3.200	13.000	-48.138	-13

Note:

1. Receiver setting (Peak Detector) : RBW:1MHz; VBW:3MHz
2. EIRP Value = Signal Generator Level + Antenna Gain - Cable Loss
3. Spurious emissions past 5 GHz are not shown, due to the magnitude of spurious emissions attenuated more than 20 dB below the limit.

Product	DCM (Data Communication Module)		
Test Mode	Spurious Emission (Radiated) - Multi Band Dipole Antenna (STAF)		
Date of Test	2017/11/15	Test Site	Site3
Test Condition	Band 26 (1.4M) CH26915 (836.5MHz)	Test Range	9kHz ~10GHz

Frequency	Reading Level	Signal Generator Level	Cable Loss	Antenna Gain	EIRP Value	Limit
(GHz)	(dBm)	(dBm)	(dB)	(dBi)	(dBm)	(dBm)

Horizontal Emissions Band 26 (1.4M) QPSK(3,0)

1673	-60.678	-63.720	1.630	9.800	-55.550	-13
2510	-57.389	-57.898	2.100	10.600	-49.398	-13
3346	-59.953	-61.601	2.350	12.300	-51.651	-13
4183	-60.748	-59.952	2.700	12.600	-50.052	-13
5019	-62.704	-58.346	2.830	12.700	-48.476	-13
5856	-63.630	-60.531	3.200	13.000	-50.731	-13

Vertical Emissions Band 26 (1.4M) QPSK(3,0)

1673	-64.246	-66.955	1.630	9.800	-58.785	-13
2510	-63.950	-63.993	2.100	10.600	-55.493	-13
3346	-60.354	-60.881	2.350	12.300	-50.931	-13
4183	-61.408	-58.998	2.700	12.600	-49.098	-13
5019	-61.599	-56.587	2.830	12.700	-46.717	-13
5856	-63.794	-60.746	3.200	13.000	-50.946	-13

Note:

1. Receiver setting (Peak Detector) : RBW:1MHz; VBW:3MHz
2. EIRP Value = Signal Generator Level + Antenna Gain - Cable Loss
3. Spurious emissions past 6 GHz are not shown, due to the magnitude of spurious emissions attenuated more than 20 dB below the limit.

Product	DCM (Data Communication Module)		
Test Mode	Spurious Emission (Radiated) - Multi Band Dipole Antenna (STAF)		
Date of Test	2017/11/15	Test Site	Site3
Test Condition	Band 26 (3M) CH26805 (825.5MHz)	Test Range	9kHz ~10GHz

Frequency	Reading Level	Signal Generator Level	Cable Loss	Antenna Gain	EIRP Value	Limit
(GHz)	(dBm)	(dBm)	(dB)	(dBi)	(dBm)	(dBm)

Horizontal Emissions Band 26 (3M) QPSK(1,7)

1651	-55.766	-59.161	1.630	9.800	-50.991	-13
2477	-59.994	-60.338	2.100	10.600	-51.838	-13
3302	-59.265	-60.943	2.350	12.300	-50.993	-13
4128	-60.527	-59.540	2.700	12.600	-49.640	-13
4953	-63.512	-59.389	2.830	12.700	-49.519	-13
5779	-63.500	-61.485	3.200	13.000	-51.685	-13

Vertical Emissions Band 26 (3M) QPSK(1,7)

1651	-61.169	-64.256	1.630	9.800	-56.086	-13
2477	-64.732	-64.809	2.100	10.600	-56.309	-13
3302	-59.352	-59.978	2.350	12.300	-50.028	-13
4128	-61.285	-58.605	2.700	12.600	-48.705	-13
4953	-61.896	-57.192	2.830	12.700	-47.322	-13
5779	-63.686	-61.544	3.200	13.000	-51.744	-13

Note:

1. Receiver setting (Peak Detector) : RBW:1MHz; VBW:3MHz
2. EIRP Value = Signal Generator Level + Antenna Gain - Cable Loss
3. Spurious emissions past 6 GHz are not shown, due to the magnitude of spurious emissions attenuated more than 20 dB below the limit.

Product	DCM (Data Communication Module)		
Test Mode	Spurious Emission (Radiated) - Multi Band Dipole Antenna (STAF)		
Date of Test	2017/11/15	Test Site	Site3
Test Condition	Band 26 (5M) CH26915 (836.5MHz)	Test Range	9kHz ~10GHz

Frequency	Reading Level	Signal Generator Level	Cable Loss	Antenna Gain	EIRP Value	Limit
(GHz)	(dBm)	(dBm)	(dB)	(dBi)	(dBm)	(dBm)

Horizontal Emissions Band 26 (5M) QPSK(1,12)

1673	-59.234	-62.276	1.630	9.800	-54.106	-13
2510	-56.603	-57.161	2.100	10.600	-48.661	-13
3346	-59.582	-61.234	2.350	12.300	-51.284	-13
4183	-60.895	-60.099	2.700	12.600	-50.199	-13
5019	-63.190	-58.832	2.830	12.700	-48.962	-13
5856	-64.120	-61.021	3.200	13.000	-51.221	-13

Vertical Emissions Band 26 (5M) QPSK(1,12)

1673	-64.269	-66.979	1.630	9.800	-58.809	-13
2510	-64.386	-64.428	2.100	10.600	-55.928	-13
3346	-60.549	-61.076	2.350	12.300	-51.126	-13
4183	-61.762	-59.352	2.700	12.600	-49.452	-13
5019	-63.038	-58.040	2.830	12.700	-48.170	-13
5856	-63.938	-60.891	3.200	13.000	-51.091	-13

Note:

1. Receiver setting (Peak Detector) : RBW:1MHz; VBW:3MHz
2. EIRP Value = Signal Generator Level + Antenna Gain - Cable Loss
3. Spurious emissions past 6 GHz are not shown, due to the magnitude of spurious emissions attenuated more than 20 dB below the limit.

Product	DCM (Data Communication Module)		
Test Mode	Spurious Emission (Radiated) - Multi Band Dipole Antenna (STAF)		
Date of Test	2017/11/15	Test Site	Site3
Test Condition	Band 26 (10M) CH26915 (836.5MHz)	Test Range	9kHz ~10GHz

Frequency	Reading Level	Signal Generator Level	Cable Loss	Antenna Gain	EIRP Value	Limit
(GHz)	(dBm)	(dBm)	(dB)	(dBi)	(dBm)	(dBm)

Horizontal Emissions Band 26 (10M) QPSK(1,24)

1673	-59.081	-62.123	1.630	9.800	-53.953	-13
2510	-56.889	-57.446	2.100	10.600	-48.946	-13
3346	-60.080	-61.732	2.350	12.300	-51.782	-13
4183	-60.923	-60.127	2.700	12.600	-50.227	-13
5019	-62.812	-58.454	2.830	12.700	-48.584	-13
5856	-64.263	-61.164	3.200	13.000	-51.364	-13

Vertical Emissions Band 26 (10M) QPSK(1,24)

1673	-63.193	-65.903	1.630	9.800	-57.733	-13
2510	-63.808	-63.850	2.100	10.600	-55.350	-13
3346	-60.217	-60.744	2.350	12.300	-50.794	-13
4183	-61.120	-58.710	2.700	12.600	-48.810	-13
5019	-62.939	-57.941	2.830	12.700	-48.071	-13
5856	-63.824	-60.776	3.200	13.000	-50.976	-13

Note:

1. Receiver setting (Peak Detector) : RBW:1MHz; VBW:3MHz
2. EIRP Value = Signal Generator Level + Antenna Gain - Cable Loss
3. Spurious emissions past 6 GHz are not shown, due to the magnitude of spurious emissions attenuated more than 20 dB below the limit.

Product	DCM (Data Communication Module)		
Test Mode	Spurious Emission (Radiated) - Multi Band Dipole Antenna (STAF)		
Date of Test	2017/11/15	Test Site	Site3
Test Condition	Band 26 (15M) CH26865 (831.5MHz)	Test Range	9kHz ~10GHz

Frequency	Reading Level	Signal Generator Level	Cable Loss	Antenna Gain	EIRP Value	Limit
(GHz)	(dBm)	(dBm)	(dB)	(dBi)	(dBm)	(dBm)

Horizontal Emissions Band 26 (15M) QPSK(1,74)

1663	-58.871	-61.913	1.630	9.800	-53.743	-13
2495	-58.273	-58.831	2.100	10.600	-50.331	-13
3326	-58.633	-60.303	2.350	12.300	-50.353	-13
4158	-61.097	-60.224	2.700	12.600	-50.324	-13
4989	-62.715	-58.476	2.830	12.700	-48.606	-13
5821	-62.961	-60.339	3.200	13.000	-50.539	-13

Vertical Emissions Band 26 (15M) QPSK(1,74)

1663	-64.485	-67.383	1.630	9.800	-59.213	-13
2495	-64.103	-64.172	2.100	10.600	-55.672	-13
3326	-59.407	-60.003	2.350	12.300	-50.053	-13
4158	-60.941	-58.381	2.700	12.600	-48.481	-13
4989	-62.688	-57.853	2.830	12.700	-47.983	-13
5821	-62.779	-59.964	3.200	13.000	-50.164	-13

Note:

1. Receiver setting (Peak Detector) : RBW:1MHz; VBW:3MHz
2. EIRP Value = Signal Generator Level + Antenna Gain - Cable Loss
3. Spurious emissions past 6 GHz are not shown, due to the magnitude of spurious emissions attenuated more than 20 dB below the limit.

Product	DCM (Data Communication Module)		
Test Mode	Spurious Emission (Radiated) - Multi Band Dipole Antenna (STAF)		
Date of Test	2017/11/15	Test Site	Site3
Test Condition	Band 41 (5M) CH39675 (2498.5MHz)	Test Range	9kHz ~26GHz

Frequency	Reading Level	Signal Generator Level	Cable Loss	Antenna Gain	EIRP Value	Limit
(GHz)	(dBm)	(dBm)	(dB)	(dBi)	(dBm)	(dBm)

Horizontal Emissions Band 41 (5M) QPSK(1,12)

4997	-64.238	-60.140	3.050	13.100	-50.090	-25
7496	-67.308	-52.895	3.650	11.500	-45.045	-25
9994	-70.411	-54.685	3.850	12.000	-46.535	-25

Vertical Emissions Band 41 (5M) QPSK(1,12)

4997	-64.008	-59.181	3.050	13.100	-49.131	-25
7496	-68.753	-53.707	3.650	11.500	-45.857	-25
9994	-70.110	-54.372	3.850	12.000	-46.222	-25

Note:

1. Receiver setting (Peak Detector) : RBW:1MHz; VBW:3MHz
2. EIRP Value = Signal Generator Level + Antenna Gain - Cable Loss
3. Spurious emissions past 11 GHz are not shown, due to the magnitude of spurious emissions attenuated more than 20 dB below the limit.

Product	DCM (Data Communication Module)		
Test Mode	Spurious Emission (Radiated) - Multi Band Dipole Antenna (STAF)		
Date of Test	2017/11/15	Test Site	Site3
Test Condition	Band 41 (10M) CH39700 (2501MHz)	Test Range	9kHz ~26GHz

Frequency	Reading Level	Signal Generator Level	Cable Loss	Antenna Gain	EIRP Value	Limit
(GHz)	(dBm)	(dBm)	(dB)	(dBi)	(dBm)	(dBm)

Horizontal Emissions Band 41 (10M) QPSK(1,24)

5002	-63.409	-59.311	3.050	13.100	-49.261	-25
7503	-68.208	-53.795	3.650	11.500	-45.945	-25
10004	-69.149	-53.496	3.850	12.000	-45.346	-25

Vertical Emissions Band 41 (10M) QPSK(1,24)

5002	-62.922	-58.096	3.050	13.100	-48.046	-25
7503	-65.414	-53.368	3.650	11.500	-45.518	-25
10004	-69.217	-53.487	3.850	12.000	-45.337	-25

Note:

1. Receiver setting (Peak Detector) : RBW:1MHz; VBW:3MHz
2. EIRP Value = Signal Generator Level + Antenna Gain - Cable Loss
3. Spurious emissions past 11 GHz are not shown, due to the magnitude of spurious emissions attenuated more than 20 dB below the limit.

Product	DCM (Data Communication Module)		
Test Mode	Spurious Emission (Radiated) - Multi Band Dipole Antenna (STAF)		
Date of Test	2017/11/15	Test Site	Site3
Test Condition	Band 41 (15M) CH39725 (2503.5MHz)	Test Range	9kHz ~26GHz

Frequency	Reading Level	Signal Generator Level	Cable Loss	Antenna Gain	EIRP Value	Limit
(GHz)	(dBm)	(dBm)	(dB)	(dBi)	(dBm)	(dBm)

Horizontal Emissions Band 41 (15M) QPSK(1,74)

5007	-61.540	-57.362	3.050	13.100	-47.312	-25
7511	-67.259	-52.912	3.650	11.500	-45.062	-25
10014	-68.910	-53.267	3.850	12.000	-45.117	-25

Vertical Emissions Band 41 (15M) QPSK(1,74)

5007	-65.026	-60.208	3.050	13.100	-50.158	-25
7511	-69.404	-54.461	3.650	11.500	-46.611	-25
10014	-70.463	-54.745	3.850	12.000	-46.595	-25

Note:

1. Receiver setting (Peak Detector) : RBW:1MHz; VBW:3MHz
2. EIRP Value = Signal Generator Level + Antenna Gain - Cable Loss
3. Spurious emissions past 11 GHz are not shown, due to the magnitude of spurious emissions attenuated more than 20 dB below the limit.

Product	DCM (Data Communication Module)		
Test Mode	Spurious Emission (Radiated) - Multi Band Dipole Antenna (STAF)		
Date of Test	2017/11/15	Test Site	Site3
Test Condition	Band 41 (20M) CH39750 (2506MHz)	Test Range	9kHz ~26GHz

Frequency	Reading Level	Signal Generator Level	Cable Loss	Antenna Gain	EIRP Value	Limit
(GHz)	(dBm)	(dBm)	(dB)	(dBi)	(dBm)	(dBm)

Horizontal Emissions Band 41 (20M) QPSK(1,49)

5012	-64.740	-60.602	3.050	13.100	-50.552	-25
7518	-67.335	-52.967	3.650	11.500	-45.117	-25
10024	-70.699	-55.066	3.850	12.000	-46.916	-25

Vertical Emissions Band 41 (20M) QPSK(1,49)

5012	-63.895	-59.062	3.050	13.100	-49.012	-25
7518	-68.350	-53.368	3.650	11.500	-45.518	-25
10024	-69.174	-53.478	3.850	12.000	-45.328	-25

Note:

1. Receiver setting (Peak Detector) : RBW:1MHz; VBW:3MHz
2. EIRP Value = Signal Generator Level + Antenna Gain - Cable Loss
3. Spurious emissions past 11 GHz are not shown, due to the magnitude of spurious emissions attenuated more than 20 dB below the limit.

Product	DCM (Data Communication Module)		
Test Mode	Spurious Emission (Radiated) - 4G/3G/2G MIMO 1 Antenna (taogles)		
Date of Test	2017/11/15	Test Site	Site3
Test Condition	Band 2 (1.4M) CH18607 (1850.7MHz)	Test Range	9kHz ~20GHz

Frequency	Reading Level	Signal Generator Level	Cable Loss	Antenna Gain	EIRP Value	Limit
(GHz)	(dBm)	(dBm)	(dB)	(dBi)	(dBm)	(dBm)

Horizontal Emissions Band 2 (1.4M) QPSK(3,3)

3701	-48.656	-49.267	2.530	12.600	-39.197	-13
5552	-57.967	-54.583	3.050	13.100	-44.533	-13
7403	-63.014	-48.387	3.650	11.500	-40.537	-13
9254	-61.773	-46.858	3.850	12.000	-38.708	-13
11104	-64.128	-46.579	4.580	12.000	-39.159	-13

Vertical Emissions Band 2 (1.4M) QPSK(3,3)

3701	-47.983	-46.348	2.530	12.600	-36.278	-13
5552	-55.160	-51.175	3.050	13.100	-41.125	-13
7403	-63.036	-47.952	3.650	11.500	-40.102	-13
9254	-62.935	-47.515	3.850	12.000	-39.365	-13
11104	-64.750	-46.999	4.580	12.000	-39.579	-13

Note:

1. Receiver setting (Peak Detector) : RBW:1MHz; VBW:3MHz
2. EIRP Value = Signal Generator Level + Antenna Gain - Cable Loss
3. Spurious emissions past 12 GHz are not shown, due to the magnitude of spurious emissions attenuated more than 20 dB below the limit.

Product	DCM (Data Communication Module)		
Test Mode	Spurious Emission (Radiated) - 4G/3G/2G MIMO 1 Antenna (taogles)		
Date of Test	2017/11/15	Test Site	Site3
Test Condition	Band 2 (3M) CH18900 (1880MHz)	Test Range	9kHz ~20GHz

Frequency	Reading Level	Signal Generator Level	Cable Loss	Antenna Gain	EIRP Value	Limit
(GHz)	(dBm)	(dBm)	(dB)	(dBi)	(dBm)	(dBm)

Horizontal Emissions Band 2 (3M) QPSK(1,7)

3760	-45.876	-46.224	2.530	12.600	-36.154	-13
5640	-56.391	-53.710	3.050	13.100	-43.660	-13
7520	-62.794	-48.426	3.650	11.500	-40.576	-13
9400	-62.292	-46.973	3.850	12.000	-38.823	-13
11280	-64.553	-48.069	4.580	12.000	-40.649	-13

Vertical Emissions Band 2 (3M) QPSK(1,7)

3760	-42.368	-40.386	2.530	12.600	-30.316	-13
5640	-52.416	-49.266	3.050	13.100	-39.216	-13
7520	-59.903	-44.921	3.650	11.500	-37.071	-13
9400	-63.167	-47.342	3.850	12.000	-39.192	-13
11280	-63.878	-47.224	4.580	12.000	-39.804	-13

Note:

1. Receiver setting (Peak Detector) : RBW:1MHz; VBW:3MHz
2. EIRP Value = Signal Generator Level + Antenna Gain - Cable Loss
3. Spurious emissions past 12 GHz are not shown, due to the magnitude of spurious emissions attenuated more than 20 dB below the limit.

Product	DCM (Data Communication Module)		
Test Mode	Spurious Emission (Radiated) - 4G/3G/2G MIMO 1 Antenna (taogles)		
Date of Test	2017/11/15	Test Site	Site3
Test Condition	Band 2 (5M) CH18900 (1880MHz)	Test Range	9kHz ~20GHz

Frequency	Reading Level	Signal Generator Level	Cable Loss	Antenna Gain	EIRP Value	Limit
(GHz)	(dBm)	(dBm)	(dB)	(dBi)	(dBm)	(dBm)

Horizontal Emissions Band 2 (5M) QPSK(1,12)

3760	-45.801	-46.149	2.530	12.600	-36.079	-13
5640	-55.776	-53.095	3.050	13.100	-43.045	-13
7520	-61.777	-47.408	3.650	11.500	-39.558	-13
9400	-63.069	-47.750	3.850	12.000	-39.600	-13
11280	-65.078	-48.617	4.580	12.000	-41.197	-13

Vertical Emissions Band 2 (5M) QPSK(1,12)

3760	-42.225	-40.243	2.530	12.600	-30.173	-13
5640	-52.932	-49.782	3.050	13.100	-39.732	-13
7520	-59.855	-44.873	3.650	11.500	-37.023	-13
9400	-63.604	-47.773	3.850	12.000	-39.623	-13
11280	-64.299	-47.645	4.580	12.000	-40.225	-13

Note:

1. Receiver setting (Peak Detector) : RBW:3MHz; VBW:3MHz
2. EIRP Value = Signal Generator Level + Antenna Gain - Cable Loss
3. Spurious emissions past 12 GHz are not shown, due to the magnitude of spurious emissions attenuated more than 20 dB below the limit.

Product	DCM (Data Communication Module)		
Test Mode	Spurious Emission (Radiated) - 4G/3G/2G MIMO 1 Antenna (taogles)		
Date of Test	2017/11/15	Test Site	Site3
Test Condition	Band 2 (10M) CH18650 (1855MHz)	Test Range	9kHz ~20GHz

Frequency	Reading Level	Signal Generator Level	Cable Loss	Antenna Gain	EIRP Value	Limit
(GHz)	(dBm)	(dBm)	(dB)	(dBi)	(dBm)	(dBm)

Horizontal Emissions Band 2 (10M) QPSK(1,24)

3710	-47.899	-48.473	2.530	12.600	-38.403	-13
5565	-58.706	-55.402	3.050	13.100	-45.352	-13
7420	-62.650	-48.080	3.650	11.500	-40.230	-13
9275	-62.504	-47.589	3.850	12.000	-39.439	-13
11130	-65.232	-47.860	4.580	12.000	-40.440	-13

Vertical Emissions Band 2 (10M) QPSK(1,24)

3710	-46.123	-44.439	2.530	12.600	-34.369	-13
5565	-56.206	-52.280	3.050	13.100	-42.230	-13
7420	-61.895	-46.808	3.650	11.500	-38.958	-13
9275	-63.013	-47.485	3.850	12.000	-39.335	-13
11130	-64.650	-47.185	4.580	12.000	-39.765	-13

Note:

1. Receiver setting (Peak Detector) : RBW:1MHz; VBW:3MHz
2. ERP Value = Signal Generator Level + Antenna Gain - Cable Loss
3. Spurious emissions past 12 GHz are not shown, due to the magnitude of spurious emissions attenuated more than 20 dB below the limit.

Product	DCM (Data Communication Module)		
Test Mode	Spurious Emission (Radiated) - 4G/3G/2G MIMO 1 Antenna (taogles)		
Date of Test	2017/11/15	Test Site	Site3
Test Condition	Band 2 (15M) CH18675 (1857.5MHz)	Test Range	9kHz ~20GHz

Frequency	Reading Level	Signal Generator Level	Cable Loss	Antenna Gain	EIRP Value	Limit
(GHz)	(dBm)	(dBm)	(dB)	(dBi)	(dBm)	(dBm)

Horizontal Emissions Band 2 (15M) QPSK(1,0)

3715	-47.980	-48.591	2.530	12.600	-38.521	-13
5573	-58.391	-55.007	3.050	13.100	-44.957	-13
7430	-63.099	-48.500	3.650	11.500	-40.650	-13
9288	-62.448	-47.452	3.850	12.000	-39.302	-13
11145	-63.740	-46.544	4.580	12.000	-39.124	-13

Vertical Emissions Band 2 (15M) QPSK(1,0)

3715	-46.108	-44.473	2.530	12.600	-34.403	-13
5573	-55.759	-51.774	3.050	13.100	-41.724	-13
7430	-63.021	-47.937	3.650	11.500	-40.087	-13
9288	-63.068	-47.432	3.850	12.000	-39.282	-13
11145	-65.447	-48.085	4.580	12.000	-40.665	-13

Note:

1. Receiver setting (Peak Detector) : RBW:1MHz; VBW:3MHz
2. EIRP Value = Signal Generator Level + Antenna Gain - Cable Loss
3. Spurious emissions past 12 GHz are not shown, due to the magnitude of spurious emissions attenuated more than 20 dB below the limit.

Product	DCM (Data Communication Module)		
Test Mode	Spurious Emission (Radiated) - 4G/3G/2G MIMO 1 Antenna (taogles)		
Date of Test	2017/11/15	Test Site	Site3
Test Condition	Band 2 (20M) CH18700 (1860MHz)	Test Range	9kHz ~20GHz

Frequency	Reading Level	Signal Generator Level	Cable Loss	Antenna Gain	EIRP Value	Limit
(GHz)	(dBm)	(dBm)	(dB)	(dBi)	(dBm)	(dBm)

Horizontal Emissions Band 2 (20M) QPSK(1,49)

3720	-46.441	-46.977	2.530	12.600	-36.907	-13
5580	-57.577	-54.432	3.050	13.100	-44.382	-13
7440	-62.250	-47.708	3.650	11.500	-39.858	-13
9300	-63.210	-48.175	3.850	12.000	-40.025	-13
11160	-65.265	-48.069	4.580	12.000	-40.649	-13

Vertical Emissions Band 2 (20M) QPSK(1,49)

3720	-43.508	-41.774	2.530	12.600	-31.704	-13
5580	-54.634	-50.826	3.050	13.100	-40.776	-13
7440	-62.955	-47.871	3.650	11.500	-40.021	-13
9300	-62.606	-46.928	3.850	12.000	-38.778	-13
11160	-65.021	-47.863	4.580	12.000	-40.443	-13

Note:

1. Receiver setting (Peak Detector) : RBW:1MHz; VBW:3MHz
2. EIRP Value = Signal Generator Level + Antenna Gain - Cable Loss
3. Spurious emissions past 12 GHz are not shown, due to the magnitude of spurious emissions attenuated more than 20 dB below the limit.

Product	DCM (Data Communication Module)		
Test Mode	Spurious Emission (Radiated) - 4G/3G/2G MIMO 1 Antenna (taogles)		
Date of Test	2017/11/15	Test Site	Site3
Test Condition	Band 4 (1.4M) CH20175 (1732.5MHz)	Test Range	9kHz ~20GHz

Frequency	Reading Level	Signal Generator Level	Cable Loss	Antenna Gain	EIRP Value	Limit
(GHz)	(dBm)	(dBm)	(dB)	(dBi)	(dBm)	(dBm)

Horizontal Emissions Band 4 (1.4M) QPSK(3,3)

3465	-54.832	-55.625	2.530	12.600	-45.555	-13
5198	-47.562	-43.524	3.050	13.100	-33.474	-13
6930	-63.733	-51.875	3.650	11.500	-44.025	-13
8663	-63.638	-48.145	3.850	12.000	-39.995	-13
10395	-60.649	-43.908	4.580	12.000	-36.488	-13
12128	-65.224	-48.122	4.800	13.300	-39.622	-13

Vertical Emissions Band 4 (1.4M) QPSK(3,3)

3465	-57.138	-57.039	2.530	12.600	-46.969	-13
5198	-50.873	-46.511	3.050	13.100	-36.461	-13
6930	-63.318	-50.955	3.650	11.500	-43.105	-13
8663	-63.837	-47.833	3.850	12.000	-39.683	-13
10395	-61.202	-44.304	4.580	12.000	-36.884	-13
12128	-65.703	-48.721	4.800	13.300	-40.221	-13

Note:

1. Receiver setting (Peak Detector) : RBW:1MHz; VBW:3MHz
2. EIRP Value = Signal Generator Level + Antenna Gain - Cable Loss
3. Spurious emissions past 13 GHz are not shown, due to the magnitude of spurious emissions attenuated more than 20 dB below the limit.

Product	DCM (Data Communication Module)		
Test Mode	Spurious Emission (Radiated) - 4G/3G/2G MIMO 1 Antenna (taogles)		
Date of Test	2017/11/15	Test Site	Site3
Test Condition	Band 4 (3M) CH20385 (1753.5MHz)	Test Range	9kHz ~20GHz

Frequency	Reading Level	Signal Generator Level	Cable Loss	Antenna Gain	EIRP Value	Limit
(GHz)	(dBm)	(dBm)	(dB)	(dBi)	(dBm)	(dBm)

Horizontal Emissions Band 4 (3M) QPSK(1,0)

3507	-54.001	-54.588	2.530	12.600	-44.518	-13
5261	-47.105	-42.944	3.050	13.100	-32.894	-13
7014	-63.094	-50.325	3.650	11.500	-42.475	-13
8768	-63.504	-47.156	3.850	12.000	-39.006	-13
10521	-61.964	-45.593	4.580	12.000	-38.173	-13
12275	-65.017	-47.201	4.800	13.300	-38.701	-13

Vertical Emissions Band 4 (3M) QPSK(1,0)

3507	-52.842	-52.370	2.530	12.600	-42.300	-13
5261	-50.262	-45.722	3.050	13.100	-35.672	-13
7014	-62.550	-49.332	3.650	11.500	-41.482	-13
8768	-62.752	-46.164	3.850	12.000	-38.014	-13
10521	-62.585	-46.197	4.580	12.000	-38.777	-13
12275	-65.101	-47.342	4.800	13.300	-38.842	-13

Note:

1. Receiver setting (Peak Detector) : RBW:1MHz; VBW:3MHz
2. EIRP Value = Signal Generator Level + Antenna Gain - Cable Loss
3. Spurious emissions past 13 GHz are not shown, due to the magnitude of spurious emissions attenuated more than 20 dB below the limit.

Product	DCM (Data Communication Module)		
Test Mode	Spurious Emission (Radiated) - 4G/3G/2G MIMO 1 Antenna (taogles)		
Date of Test	2017/11/15	Test Site	Site3
Test Condition	Band 4 (5M) CH20375 (1752.5MHz)	Test Range	9kHz ~20GHz

Frequency	Reading Level	Signal Generator Level	Cable Loss	Antenna Gain	EIRP Value	Limit
(GHz)	(dBm)	(dBm)	(dB)	(dBi)	(dBm)	(dBm)

Horizontal Emissions Band 4 (5M) QPSK(1,12)

3505	-53.637	-54.224	2.530	12.600	-44.154	-13
5258	-47.290	-43.129	3.050	13.100	-33.079	-13
7010	-64.163	-51.343	3.650	11.500	-43.493	-13
8763	-62.328	-46.161	3.850	12.000	-38.011	-13
10515	-62.477	-46.107	4.580	12.000	-38.687	-13
12268	-64.847	-47.032	4.800	13.300	-38.532	-13

Vertical Emissions Band 4 (5M) QPSK(1,12)

3505	-53.454	-52.982	2.530	12.600	-42.912	-13
5258	-49.367	-44.827	3.050	13.100	-34.777	-13
7010	-63.109	-49.502	3.650	11.500	-41.652	-13
8763	-63.610	-46.819	3.850	12.000	-38.669	-13
10515	-62.310	-45.931	4.580	12.000	-38.511	-13
12268	-65.384	-47.625	4.800	13.300	-39.125	-13

Note:

1. Receiver setting (Peak Detector) : RBW:1MHz; VBW:3MHz
2. EIRP Value = Signal Generator Level + Antenna Gain - Cable Loss
3. Spurious emissions past 13 GHz are not shown, due to the magnitude of spurious emissions attenuated more than 20 dB below the limit.

Product	DCM (Data Communication Module)		
Test Mode	Spurious Emission (Radiated) - 4G/3G/2G MIMO 1 Antenna (taogles)		
Date of Test	2017/11/15	Test Site	Site3
Test Condition	Band 4 (10M) CH20350 (1750MHz)	Test Range	9kHz ~20GHz

Frequency	Reading Level	Signal Generator Level	Cable Loss	Antenna Gain	EIRP Value	Limit
(GHz)	(dBm)	(dBm)	(dB)	(dBi)	(dBm)	(dBm)

Horizontal Emissions Band 4 (10M) QPSK(1,24)

3500	-55.170	-55.757	2.530	12.600	-45.687	-13
5250	-48.262	-44.101	3.050	13.100	-34.051	-13
7000	-63.031	-50.263	3.650	11.500	-42.413	-13
8750	-63.541	-47.375	3.850	12.000	-39.225	-13
10500	-61.328	-44.947	4.580	12.000	-37.527	-13
12250	-64.538	-46.852	4.800	13.300	-38.352	-13

Vertical Emissions Band 4 (10M) QPSK(1,24)

3500	-54.525	-54.053	2.530	12.600	-43.983	-13
5250	-50.531	-45.991	3.050	13.100	-35.941	-13
7000	-62.741	-49.357	3.650	11.500	-41.507	-13
8750	-63.200	-46.511	3.850	12.000	-38.361	-13
10500	-61.806	-45.369	4.580	12.000	-37.949	-13
12250	-64.656	-46.897	4.800	13.300	-38.397	-13

Note:

1. Receiver setting (Peak Detector) : RBW:1MHz; VBW:3MHz
2. EIRP Value = Signal Generator Level + Antenna Gain - Cable Loss
3. Spurious emissions past 13 GHz are not shown, due to the magnitude of spurious emissions attenuated more than 20 dB below the limit.

Product	DCM (Data Communication Module)		
Test Mode	Spurious Emission (Radiated) - 4G/3G/2G MIMO 1 Antenna (taogles)		
Date of Test	2017/11/15	Test Site	Site3
Test Condition	Band 4 (15M) CH20325 (1747.5MHz)	Test Range	9kHz ~20GHz

Frequency	Reading Level	Signal Generator Level	Cable Loss	Antenna Gain	EIRP Value	Limit
(GHz)	(dBm)	(dBm)	(dB)	(dBi)	(dBm)	(dBm)

Horizontal Emissions Band 4 (15M) QPSK(1,37)

3495	-55.222	-55.805	2.530	12.600	-45.735	-13
5243	-49.734	-45.594	3.050	13.100	-35.544	-13
6990	-63.913	-51.197	3.650	11.500	-43.347	-13
8738	-61.066	-45.176	3.850	12.000	-37.026	-13
10485	-62.488	-46.108	4.580	12.000	-38.688	-13
12233	-65.237	-47.682	4.800	13.300	-39.182	-13

Vertical Emissions Band 4 (15M) QPSK(1,37)

3495	-56.868	-56.475	2.530	12.600	-46.405	-13
5243	-51.444	-46.946	3.050	13.100	-36.896	-13
6990	-63.105	-49.721	3.650	11.500	-41.871	-13
8738	-63.065	-46.478	3.850	12.000	-38.328	-13
10485	-62.564	-46.070	4.580	12.000	-38.650	-13
12233	-64.746	-47.295	4.800	13.300	-38.795	-13

Note:

1. Receiver setting (Peak Detector) : RBW:1MHz; VBW:3MHz
2. EIRP Value = Signal Generator Level + Antenna Gain - Cable Loss
3. Spurious emissions past 13 GHz are not shown, due to the magnitude of spurious emissions attenuated more than 20 dB below the limit.

Product	DCM (Data Communication Module)		
Test Mode	Spurious Emission (Radiated) - 4G/3G/2G MIMO 1 Antenna (taogles)		
Date of Test	2017/11/15	Test Site	Site3
Test Condition	Band 4 (20M) CH20300 (1745MHz)	Test Range	9kHz ~20GHz

Frequency	Reading Level	Signal Generator Level	Cable Loss	Antenna Gain	EIRP Value	Limit
(GHz)	(dBm)	(dBm)	(dB)	(dBi)	(dBm)	(dBm)

Horizontal Emissions Band 4 (20M) QPSK(1,49)

3490	-53.364	-53.947	2.530	12.600	-43.877	-13
5235	-47.406	-43.287	3.050	13.100	-33.237	-13
6980	-62.806	-50.329	3.650	11.500	-42.479	-13
8725	-62.690	-46.891	3.850	12.000	-38.741	-13
10470	-60.530	-44.076	4.580	12.000	-36.656	-13
12215	-64.938	-47.512	4.800	13.300	-39.012	-13

Vertical Emissions Band 4 (20M) QPSK(1,49)

3490	-55.644	-55.324	2.530	12.600	-45.254	-13
5235	-50.442	-45.986	3.050	13.100	-35.936	-13
6980	-62.687	-49.138	3.650	11.500	-41.288	-13
8725	-63.279	-46.895	3.850	12.000	-38.745	-13
10470	-61.790	-45.234	4.580	12.000	-37.814	-13
12215	-65.255	-47.958	4.800	13.300	-39.458	-13

Note:

1. Receiver setting (Peak Detector) : RBW:1MHz; VBW:3MHz
2. EIRP Value = Signal Generator Level + Antenna Gain - Cable Loss
3. Spurious emissions past 13 GHz are not shown, due to the magnitude of spurious emissions attenuated more than 20 dB below the limit.

Product	DCM (Data Communication Module)		
Test Mode	Spurious Emission (Radiated) - 4G/3G/2G MIMO 1 Antenna (taogles)		
Date of Test	2017/11/15	Test Site	Site3
Test Condition	Band 5 (1.4M) CH20643 (848.3MHz)	Test Range	9kHz ~10GHz

Frequency	Reading Level	Signal Generator Level	Cable Loss	Antenna Gain	EIRP Value	Limit
(GHz)	(dBm)	(dBm)	(dB)	(dBi)	(dBm)	(dBm)

Horizontal Emissions Band 5 (1.4M) QPSK(3,0)

1697	-50.052	-52.809	1.630	9.800	-44.639	-13
2545	-64.577	-65.381	2.100	10.600	-56.881	-13
3393	-60.833	-62.263	2.350	12.300	-52.313	-13
4242	-61.495	-59.842	2.700	12.600	-49.942	-13
5090	-62.687	-58.138	2.830	12.700	-48.268	-13
5938	-64.137	-59.972	3.200	13.000	-50.172	-13

Vertical Emissions Band 5 (1.4M) QPSK(3,0)

1697	-48.887	-51.220	1.630	9.800	-43.050	-13
2545	-63.145	-63.143	2.100	10.600	-54.643	-13
3393	-60.878	-61.266	2.350	12.300	-51.316	-13
4242	-60.952	-58.138	2.700	12.600	-48.238	-13
5090	-62.532	-57.686	2.830	12.700	-47.816	-13
5938	-62.966	-58.776	3.200	13.000	-48.976	-13

Note:

1. Receiver setting (Peak Detector) : RBW:1MHz; VBW:3MHz
2. EIRP Value = Signal Generator Level + Antenna Gain - Cable Loss
3. Spurious emissions past 6 GHz are not shown, due to the magnitude of spurious emissions attenuated more than 20 dB below the limit.

Product	DCM (Data Communication Module)		
Test Mode	Spurious Emission (Radiated) - 4G/3G/2G MIMO 1 Antenna (taogles)		
Date of Test	2017/11/15	Test Site	Site3
Test Condition	Band 5 (3M) CH20525 (836.5MHz)	Test Range	9kHz ~10GHz

Frequency	Reading Level	Signal Generator Level	Cable Loss	Antenna Gain	EIRP Value	Limit
(GHz)	(dBm)	(dBm)	(dB)	(dBi)	(dBm)	(dBm)

Horizontal Emissions Band 5 (3M) QPSK(1,7)

1673	-56.230	-59.272	1.630	9.800	-51.102	-13
2510	-63.466	-64.024	2.100	10.600	-55.524	-13
3346	-59.461	-61.117	2.350	12.300	-51.167	-13
4183	-61.367	-60.571	2.700	12.600	-50.671	-13
5019	-63.082	-58.724	2.830	12.700	-48.854	-13
5856	-64.605	-61.506	3.200	13.000	-51.706	-13

Vertical Emissions Band 5 (3M) QPSK(1,7)

1673	-54.270	-56.980	1.630	9.800	-48.810	-13
2510	-61.903	-61.945	2.100	10.600	-53.445	-13
3346	-59.749	-60.258	2.350	12.300	-50.308	-13
4183	-61.644	-59.234	2.700	12.600	-49.334	-13
5019	-61.908	-56.897	2.830	12.700	-47.027	-13
5856	-63.775	-60.727	3.200	13.000	-50.927	-13

Note:

1. Receiver setting (Peak Detector) : RBW:1MHz; VBW:3MHz
2. EIRP Value = Signal Generator Level + Antenna Gain - Cable Loss
3. Spurious emissions past 6 GHz are not shown, due to the magnitude of spurious emissions attenuated more than 20 dB below the limit.

Product	DCM (Data Communication Module)		
Test Mode	Spurious Emission (Radiated) - 4G/3G/2G MIMO 1 Antenna (taogles)		
Date of Test	2017/11/15	Test Site	Site3
Test Condition	Band 5 (5M) CH20625 (846.5MHz)	Test Range	9kHz ~10GHz

Frequency	Reading Level	Signal Generator Level	Cable Loss	Antenna Gain	EIRP Value	Limit
(GHz)	(dBm)	(dBm)	(dB)	(dBi)	(dBm)	(dBm)

Horizontal Emissions Band 5 (5M) QPSK(1,12)

1693	-53.156	-55.975	1.630	9.800	-47.805	-13
2540	-64.694	-65.547	2.100	10.600	-57.047	-13
3386	-59.881	-61.435	2.350	12.300	-51.485	-13
4233	-61.668	-60.293	2.700	12.600	-50.393	-13
5079	-62.432	-57.866	2.830	12.700	-47.996	-13
5926	-63.295	-59.262	3.200	13.000	-49.462	-13

Vertical Emissions Band 5 (5M) QPSK(1,12)

1693	-54.010	-56.437	1.630	9.800	-48.267	-13
2540	-64.506	-64.503	2.100	10.600	-56.003	-13
3386	-60.465	-60.870	2.350	12.300	-50.920	-13
4233	-61.799	-58.910	2.700	12.600	-49.010	-13
5079	-62.529	-57.670	2.830	12.700	-47.800	-13
5926	-64.389	-60.246	3.200	13.000	-50.446	-13

Note:

1. Receiver setting (Peak Detector) : RBW:1MHz; VBW:3MHz
2. EIRP Value = Signal Generator Level + Antenna Gain - Cable Loss
3. Spurious emissions past 6 GHz are not shown, due to the magnitude of spurious emissions attenuated more than 20 dB below the limit.

Product	DCM (Data Communication Module)		
Test Mode	Spurious Emission (Radiated) - 4G/3G/2G MIMO 1 Antenna (taogles)		
Date of Test	2017/11/15	Test Site	Site3
Test Condition	Band 5 (10M) CH20600 (844MHz)	Test Range	9kHz ~10GHz

Frequency	Reading Level	Signal Generator Level	Cable Loss	Antenna Gain	EIRP Value	Limit
(GHz)	(dBm)	(dBm)	(dB)	(dBi)	(dBm)	(dBm)

Horizontal Emissions Band 5 (10M) QPSK(1,24)

1688	-54.555	-57.437	1.630	9.800	-49.267	-13
2532	-63.565	-64.270	2.100	10.600	-55.770	-13
3376	-61.145	-62.779	2.350	12.300	-52.829	-13
4220	-62.307	-60.932	2.700	12.600	-51.032	-13
5064	-63.353	-58.827	2.830	12.700	-48.957	-13
5908	-63.959	-60.124	3.200	13.000	-50.324	-13

Vertical Emissions Band 5 (10M) QPSK(1,24)

1688	-51.916	-54.437	1.630	9.800	-46.267	-13
2532	-62.628	-62.643	2.100	10.600	-54.143	-13
3376	-59.906	-60.328	2.350	12.300	-50.378	-13
4220	-61.439	-58.625	2.700	12.600	-48.725	-13
5064	-61.306	-56.421	2.830	12.700	-46.551	-13
5908	-63.630	-59.642	3.200	13.000	-49.842	-13

Note:

1. Receiver setting (Peak Detector) : RBW:1MHz; VBW:3MHz
2. EIRP Value = Signal Generator Level + Antenna Gain - Cable Loss
3. Spurious emissions past 6 GHz are not shown, due to the magnitude of spurious emissions attenuated more than 20 dB below the limit.

Product	DCM (Data Communication Module)		
Test Mode	Spurious Emission (Radiated) - 4G/3G/2G MIMO 2 Antenna (taogles)		
Date of Test	2017/11/15	Test Site	Site3
Test Condition	Band 17 (5M) CH23755 (706.5MHz)	Test Range	9KHz ~10GHz

Frequency	Reading Level	Signal Generator Level	Cable Loss	Antenna Gain	EIRP Value	Limit
(GHz)	(dBm)	(dBm)	(dB)	(dBi)	(dBm)	(dBm)

Horizontal Emissions Band 17 (5M) QPSK(1,12)

1413	-54.665	-59.123	1.630	9.800	-50.953	-13
2120	-62.488	-63.039	2.100	10.600	-54.539	-13
2826	-63.576	-65.412	2.350	12.300	-55.462	-13
3533	-59.766	-60.205	2.700	12.600	-50.305	-13
4239	-61.710	-60.119	2.830	12.700	-50.249	-13
4946	-62.614	-58.457	3.200	13.000	-48.657	-13

Vertical Emissions Band 17 (5M) QPSK(1,12)

1413	-51.984	-55.380	1.630	9.800	-47.210	-13
2120	-62.805	-63.516	2.100	10.600	-55.016	-13
2826	-63.204	-63.802	2.350	12.300	-53.852	-13
3533	-59.262	-58.456	2.700	12.600	-48.556	-13
4239	-62.296	-59.452	2.830	12.700	-49.582	-13
4946	-63.104	-58.418	3.200	13.000	-48.618	-13

Note:

1. Receiver setting (Peak Detector) : RBW:1MHz; VBW:3MHz
2. EIRP Value = Signal Generator Level + Antenna Gain - Cable Loss
3. Spurious emissions past 5 GHz are not shown, due to the magnitude of spurious emissions attenuated more than 20 dB below the limit.

Product	DCM (Data Communication Module)		
Test Mode	Spurious Emission (Radiated) - 4G/3G/2G MIMO 2 Antenna (taogles)		
Date of Test	2017/11/15	Test Site	Site3
Test Condition	Band 17 (10M) CH23780 (709MHz)	Test Range	9KHz ~10GHz

Frequency	Reading Level	Signal Generator Level	Cable Loss	Antenna Gain	EIRP Value	Limit
(GHz)	(dBm)	(dBm)	(dB)	(dBi)	(dBm)	(dBm)

Horizontal Emissions Band 17 (10M) QPSK(1,0)

1418	-50.772	-55.207	1.630	9.800	-47.037	-13
2127	-63.607	-64.158	2.100	10.600	-55.658	-13
2836	-63.903	-65.704	2.350	12.300	-55.754	-13
3545	-59.371	-59.820	2.700	12.600	-49.920	-13
4254	-61.888	-60.019	2.830	12.700	-50.149	-13
4963	-62.168	-57.921	3.200	13.000	-48.121	-13

Vertical Emissions Band 17 (10M) QPSK(1,0)

1418	-48.730	-52.126	1.630	9.800	-43.956	-13
2127	-63.193	-63.904	2.100	10.600	-55.404	-13
2836	-64.468	-65.040	2.350	12.300	-55.090	-13
3545	-60.017	-58.964	2.700	12.600	-49.064	-13
4254	-61.711	-58.792	2.830	12.700	-48.922	-13
4963	-62.692	-58.093	3.200	13.000	-48.293	-13

Note:

1. Receiver setting (Peak Detector) : RBW:1MHz; VBW:3MHz
2. EIRP Value = Signal Generator Level + Antenna Gain - Cable Loss
3. Spurious emissions past 5 GHz are not shown, due to the magnitude of spurious emissions attenuated more than 20 dB below the limit.

Product	DCM (Data Communication Module)		
Test Mode	Spurious Emission (Radiated) - 4G/3G/2G MIMO 1 Antenna (taogles)		
Date of Test	2017/11/15	Test Site	Site3
Test Condition	Band 26 (1.4M) CH26915 (836.5MHz)	Test Range	9kHz ~10GHz

Frequency	Reading Level	Signal Generator Level	Cable Loss	Antenna Gain	EIRP Value	Limit
(GHz)	(dBm)	(dBm)	(dB)	(dBi)	(dBm)	(dBm)

Horizontal Emissions Band 26 (1.4M) QPSK(3,0)

1673	-57.236	-60.278	1.630	9.800	-52.108	-13
2510	-62.942	-63.451	2.100	10.600	-54.951	-13
3346	-59.601	-61.249	2.350	12.300	-51.299	-13
4183	-60.817	-60.021	2.700	12.600	-50.121	-13
5019	-62.292	-57.934	2.830	12.700	-48.064	-13
5856	-63.554	-60.455	3.200	13.000	-50.655	-13

Vertical Emissions Band 26 (1.4M) QPSK(3,0)

1673	-55.691	-58.400	1.630	9.800	-50.230	-13
2510	-63.112	-63.162	2.100	10.600	-54.662	-13
3346	-60.124	-60.651	2.350	12.300	-50.701	-13
4183	-61.344	-58.934	2.700	12.600	-49.034	-13
5019	-62.327	-57.316	2.830	12.700	-47.446	-13
5856	-63.643	-60.595	3.200	13.000	-50.795	-13

Note:

1. Receiver setting (Peak Detector) : RBW:1MHz; VBW:3MHz
2. EIRP Value = Signal Generator Level + Antenna Gain - Cable Loss
3. Spurious emissions past 6 GHz are not shown, due to the magnitude of spurious emissions attenuated more than 20 dB below the limit.

Product	DCM (Data Communication Module)		
Test Mode	Spurious Emission (Radiated) - 4G/3G/2G MIMO 1 Antenna (taogles)		
Date of Test	2017/11/15	Test Site	Site3
Test Condition	Band 26 (3M) CH26805 (825.5MHz)	Test Range	9kHz ~10GHz

Frequency	Reading Level	Signal Generator Level	Cable Loss	Antenna Gain	EIRP Value	Limit
(GHz)	(dBm)	(dBm)	(dB)	(dBi)	(dBm)	(dBm)

Horizontal Emissions Band 26 (3M) QPSK(1,7)

1651	-57.864	-61.259	1.630	9.800	-53.089	-13
2477	-62.646	-62.990	2.100	10.600	-54.490	-13
3302	-59.813	-61.491	2.350	12.300	-51.541	-13
4128	-60.757	-59.770	2.700	12.600	-49.870	-13
4953	-62.286	-58.199	2.830	12.700	-48.329	-13
5779	-64.373	-62.359	3.200	13.000	-52.559	-13

Vertical Emissions Band 26 (3M) QPSK(1,7)

1651	-56.207	-59.293	1.630	9.800	-51.123	-13
2477	-62.116	-62.193	2.100	10.600	-53.693	-13
3302	-59.856	-60.482	2.350	12.300	-50.532	-13
4128	-60.427	-57.687	2.700	12.600	-47.787	-13
4953	-62.398	-57.650	2.830	12.700	-47.780	-13
5779	-64.425	-62.283	3.200	13.000	-52.483	-13

Note:

1. Receiver setting (Peak Detector) : RBW:1MHz; VBW:3MHz
2. EIRP Value = Signal Generator Level + Antenna Gain - Cable Loss
3. Spurious emissions past 6 GHz are not shown, due to the magnitude of spurious emissions attenuated more than 20 dB below the limit.

Product	DCM (Data Communication Module)		
Test Mode	Spurious Emission (Radiated) - 4G/3G/2G MIMO 1 Antenna (taogles)		
Date of Test	2017/11/15	Test Site	Site3
Test Condition	Band 26 (5M) CH26915 (836.5MHz)	Test Range	9kHz ~10GHz

Frequency	Reading Level	Signal Generator Level	Cable Loss	Antenna Gain	EIRP Value	Limit
(GHz)	(dBm)	(dBm)	(dB)	(dBi)	(dBm)	(dBm)

Horizontal Emissions Band 26 (5M) QPSK(1,12)

1673	-57.194	-60.236	1.630	9.800	-52.066	-13
2510	-63.421	-63.978	2.100	10.600	-55.478	-13
3346	-58.965	-60.613	2.350	12.300	-50.663	-13
4183	-60.819	-59.891	2.700	12.600	-49.991	-13
5019	-62.191	-57.857	2.830	12.700	-47.987	-13
5856	-63.622	-60.523	3.200	13.000	-50.723	-13

Vertical Emissions Band 26 (5M) QPSK(1,12)

1673	-56.035	-58.744	1.630	9.800	-50.574	-13
2510	-62.855	-62.897	2.100	10.600	-54.397	-13
3346	-60.021	-60.548	2.350	12.300	-50.598	-13
4183	-61.346	-58.936	2.700	12.600	-49.036	-13
5019	-62.801	-57.803	2.830	12.700	-47.933	-13
5856	-63.058	-59.894	3.200	13.000	-50.094	-13

Note:

1. Receiver setting (Peak Detector) : RBW:1MHz; VBW:3MHz
2. EIRP Value = Signal Generator Level + Antenna Gain - Cable Loss
3. Spurious emissions past 6 GHz are not shown, due to the magnitude of spurious emissions attenuated more than 20 dB below the limit.

Product	DCM (Data Communication Module)		
Test Mode	Spurious Emission (Radiated) - 4G/3G/2G MIMO 1 Antenna (taogles)		
Date of Test	2017/11/15	Test Site	Site3
Test Condition	Band 26 (10M) CH26915 (836.5MHz)	Test Range	9kHz ~10GHz

Frequency	Reading Level	Signal Generator Level	Cable Loss	Antenna Gain	EIRP Value	Limit
(GHz)	(dBm)	(dBm)	(dB)	(dBi)	(dBm)	(dBm)

Horizontal Emissions Band 26 (10M) QPSK(1,24)

1673	-58.162	-61.203	1.630	9.800	-53.033	-13
2510	-63.721	-64.278	2.100	10.600	-55.778	-13
3346	-60.447	-62.099	2.350	12.300	-52.149	-13
4183	-60.860	-60.064	2.700	12.600	-50.164	-13
5019	-63.091	-58.733	2.830	12.700	-48.863	-13
5856	-63.348	-60.154	3.200	13.000	-50.354	-13

Vertical Emissions Band 26 (10M) QPSK(1,24)

1673	-55.509	-58.219	1.630	9.800	-50.049	-13
2510	-61.487	-61.529	2.100	10.600	-53.029	-13
3346	-60.161	-60.688	2.350	12.300	-50.738	-13
4183	-60.579	-58.229	2.700	12.600	-48.329	-13
5019	-63.222	-58.224	2.830	12.700	-48.354	-13
5856	-63.950	-60.902	3.200	13.000	-51.102	-13

Note:

1. Receiver setting (Peak Detector) : RBW:1MHz; VBW:3MHz
2. EIRP Value = Signal Generator Level + Antenna Gain - Cable Loss
3. Spurious emissions past 6 GHz are not shown, due to the magnitude of spurious emissions attenuated more than 20 dB below the limit.

Product	DCM (Data Communication Module)		
Test Mode	Spurious Emission (Radiated) - 4G/3G/2G MIMO 1 Antenna (taogles)		
Date of Test	2017/11/15	Test Site	Site3
Test Condition	Band 26 (15M) CH26865 (831.5MHz)	Test Range	9kHz ~10GHz

Frequency	Reading Level	Signal Generator Level	Cable Loss	Antenna Gain	EIRP Value	Limit
(GHz)	(dBm)	(dBm)	(dB)	(dBi)	(dBm)	(dBm)

Horizontal Emissions Band 26 (15M) QPSK(1,74)

1663	-58.958	-61.911	1.630	9.800	-53.741	-13
2495	-63.491	-64.049	2.100	10.600	-55.549	-13
3326	-59.381	-61.037	2.350	12.300	-51.087	-13
4158	-60.722	-59.827	2.700	12.600	-49.927	-13
4989	-62.474	-58.235	2.830	12.700	-48.365	-13
5821	-62.798	-60.080	3.200	13.000	-50.280	-13

Vertical Emissions Band 26 (15M) QPSK(1,74)

1663	-53.802	-56.512	1.630	9.800	-48.342	-13
2495	-62.688	-62.730	2.100	10.600	-54.230	-13
3326	-59.096	-59.640	2.350	12.300	-49.690	-13
4158	-60.003	-57.533	2.700	12.600	-47.633	-13
4989	-63.622	-58.656	2.830	12.700	-48.786	-13
5821	-64.176	-61.828	3.200	13.000	-52.028	-13

Note:

1. Receiver setting (Peak Detector) : RBW:1MHz; VBW:3MHz
2. EIRP Value = Signal Generator Level + Antenna Gain - Cable Loss
3. Spurious emissions past 6 GHz are not shown, due to the magnitude of spurious emissions attenuated more than 20 dB below the limit.

Product	DCM (Data Communication Module)		
Test Mode	Spurious Emission (Radiated) - 4G/3G/2G MIMO 2 Antenna (taogles)		
Date of Test	2017/11/15	Test Site	Site3
Test Condition	Band 41 (5M) CH39675 (2498.5MHz)	Test Range	9kHz ~26GHz

Frequency	Reading Level	Signal Generator Level	Cable Loss	Antenna Gain	EIRP Value	Limit
(GHz)	(dBm)	(dBm)	(dB)	(dBi)	(dBm)	(dBm)

Horizontal Emissions Band 41 (5M) QPSK(1,12)

4997	-62.791	-58.693	3.050	13.100	-48.643	-25
7496	-67.447	-53.034	3.650	11.500	-45.184	-25
9994	-70.271	-54.584	3.850	12.000	-46.434	-25

Vertical Emissions Band 41 (5M) QPSK(1,12)

4997	-59.877	-55.050	3.050	13.100	-45.000	-25
7496	-67.996	-52.950	3.650	11.500	-45.100	-25
9994	-70.139	-54.401	3.850	12.000	-46.251	-25

Note:

1. Receiver setting (Peak Detector) : RBW:1MHz; VBW:3MHz
2. EIRP Value = Signal Generator Level + Antenna Gain - Cable Loss
3. Spurious emissions past 11 GHz are not shown, due to the magnitude of spurious emissions attenuated more than 20 dB below the limit.

Product	DCM (Data Communication Module)		
Test Mode	Spurious Emission (Radiated) - 4G/3G/2G MIMO 2 Antenna (taogles)		
Date of Test	2017/11/15	Test Site	Site3
Test Condition	Band 41 (10M) CH39700 (2501MHz)	Test Range	9kHz ~26GHz

Frequency	Reading Level	Signal Generator Level	Cable Loss	Antenna Gain	EIRP Value	Limit
(GHz)	(dBm)	(dBm)	(dB)	(dBi)	(dBm)	(dBm)

Horizontal Emissions Band 41 (10M) QPSK(1,24)

5002	-63.174	-59.076	3.050	13.100	-49.026	-25
7503	-67.868	-53.455	3.650	11.500	-45.605	-25
10004	-69.578	-53.925	3.850	12.000	-45.775	-25

Vertical Emissions Band 41 (10M) QPSK(1,24)

5002	-62.272	-57.445	3.050	13.100	-47.395	-25
7503	-68.780	-53.734	3.650	11.500	-45.884	-25
10004	-69.065	-53.335	3.850	12.000	-45.185	-25

Note:

1. Receiver setting (Peak Detector) : RBW:1MHz; VBW:3MHz
2. EIRP Value = Signal Generator Level + Antenna Gain - Cable Loss
3. Spurious emissions past 11 GHz are not shown, due to the magnitude of spurious emissions attenuated more than 20 dB below the limit.

Product	DCM (Data Communication Module)		
Test Mode	Spurious Emission (Radiated) - 4G/3G/2G MIMO 2 Antenna (taogles)		
Date of Test	2017/11/15	Test Site	Site3
Test Condition	Band 41 (15M) CH39725 (2503.5MHz)	Test Range	9kHz ~26GHz

Frequency	Reading Level	Signal Generator Level	Cable Loss	Antenna Gain	EIRP Value	Limit
(GHz)	(dBm)	(dBm)	(dB)	(dBi)	(dBm)	(dBm)

Horizontal Emissions Band 41 (15M) QPSK(1,74)

5007	-61.965	-57.787	3.050	13.100	-47.737	-25
7511	-67.727	-53.380	3.650	11.500	-45.530	-25
10014	-69.334	-53.691	3.850	12.000	-45.541	-25

Vertical Emissions Band 41 (15M) QPSK(1,74)

5007	-60.687	-55.869	3.050	13.100	-45.819	-25
7511	-68.673	-53.730	3.650	11.500	-45.880	-25
10014	-70.088	-54.370	3.850	12.000	-46.220	-25

Note:

1. Receiver setting (Peak Detector) : RBW:1MHz; VBW:3MHz
2. EIRP Value = Signal Generator Level + Antenna Gain - Cable Loss
3. Spurious emissions past 11 GHz are not shown, due to the magnitude of spurious emissions attenuated more than 20 dB below the limit.

Product	DCM (Data Communication Module)		
Test Mode	Spurious Emission (Radiated) - 4G/3G/2G MIMO 2 Antenna (taogles)		
Date of Test	2017/11/15	Test Site	Site3
Test Condition	Band 41 (20M) CH39750 (2506MHz)	Test Range	9kHz ~26GHz

Frequency	Reading Level	Signal Generator Level	Cable Loss	Antenna Gain	EIRP Value	Limit
(GHz)	(dBm)	(dBm)	(dB)	(dBi)	(dBm)	(dBm)

Horizontal Emissions Band 41 (20M) QPSK(1,49)

5012	-64.697	-60.559	3.050	13.100	-50.509	-25
7518	-67.570	-53.201	3.650	11.500	-45.351	-25
10024	-69.283	-53.650	3.850	12.000	-45.500	-25

Vertical Emissions Band 41 (20M) QPSK(1,49)

5012	-62.636	-57.803	3.050	13.100	-47.753	-25
7518	-68.697	-53.715	3.650	11.500	-45.865	-25
10024	-69.379	-53.683	3.850	12.000	-45.533	-25

Note:

1. Receiver setting (Peak Detector) : RBW:1MHz; VBW:3MHz
2. EIRP Value = Signal Generator Level + Antenna Gain - Cable Loss
3. Spurious emissions past 11 GHz are not shown, due to the magnitude of spurious emissions attenuated more than 20 dB below the limit.

7. Frequency Stability Under Temperature & Voltage Variations

7.1. Test Specification

According to Part 2.1055, 22.355, 24.235, 27.54

7.2. Test Setup

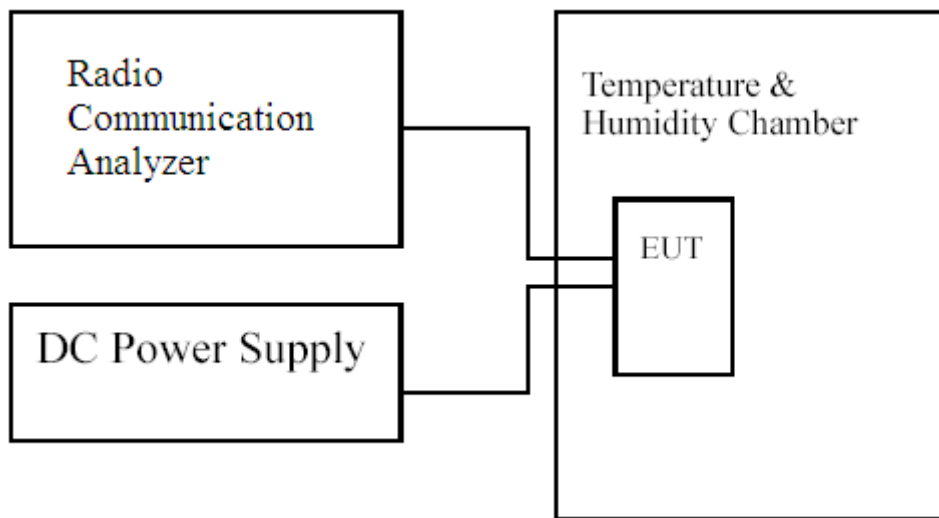

7.3. Limits

Limit	$<\pm 2.5\text{ppm}$
-------	----------------------

7.4. Test Procedure

The frequency stability of transmitter is measured by:

- (a) Temperature: The temperature is varied from -30°C to 50°C in 10°C increment using a standard temperature & Humidity chamber.
- (b) Primary Supply Voltage: The primary supply voltage is varied 85% to 115% of the nominal value for non hand-carried equipment. For hand-carried, battery-powered equipment, primary supply voltage is reduced to the battery operating endpoint which shall be specified by the manufacturer.

The EUT was connected via the base station simulator. Universal Radio Communication Tester, (MT8820C), was used to measure The Frequency Error. The maximum result of measurements was recorded.

7.5. Test Result of Frequency Stability Under Temperature Variations

Product	DCM (Data Communication Module)		
Test Mode	Frequency Stability Under Temperature Variations & Voltage Variations		
Date of Test	2017/11/17	Test Site	CTR
Test Condition	Band 2 (1.4M) CH18900(1880MHz) –QPSK	Test Range	-30°C ~+50°C

Frequency Stability Under Temperature Variations

Temperature Interval(°C)	Test Frequency (GHz)	Deviation (kHz)	Limit (kHz)
-30	1.88	-0.0097	±4.70
-20	1.88	-0.0086	±4.70
-10	1.88	-0.0082	±4.70
0	1.88	-0.0088	±4.70
10	1.88	-0.0080	±4.70
20	1.88	-0.0092	±4.70
30	1.88	-0.0078	±4.70
40	1.88	-0.0082	±4.70
50	1.88	-0.0097	±4.70

Voltage Variations

DC Voltage (V)	Test Frequency (GHz)	Deviation (kHz)	Limit (kHz)
13.8	1.88	-0.0093	±4.70
12	1.88	-0.0092	±4.70
10.2	1.88	-0.0095	±4.70

Product	DCM (Data Communication Module)		
Test Mode	Frequency Stability Under Temperature Variations & Voltage Variations		
Date of Test	2017/11/17	Test Site	CTR
Test Condition	Band 2 (1.4M) CH18900(1880MHz) -16QAM	Test Range	-30°C ~+50°C

Frequency Stability Under Temperature Variations

Temperature Interval(°C)	Test Frequency (GHz)	Deviation (kHz)	Limit (kHz)
-30	1.88	-0.0105	±4.70
-20	1.88	-0.0124	±4.70
-10	1.88	-0.0065	±4.70
0	1.88	-0.0075	±4.70
10	1.88	-0.0066	±4.70
20	1.88	-0.0091	±4.70
30	1.88	-0.0082	±4.70
40	1.88	-0.0095	±4.70
50	1.88	-0.0107	±4.70

Voltage Variations

DC Voltage (V)	Test Frequency (GHz)	Deviation (kHz)	Limit (kHz)
13.8	1.88	-0.0088	±4.70
12	1.88	-0.0091	±4.70
10.2	1.88	-0.0090	±4.70

Product	DCM (Data Communication Module)		
Test Mode	Frequency Stability Under Temperature Variations & Voltage Variations		
Date of Test	2017/11/17	Test Site	CTR
Test Condition	Band 2 (3M) CH18900(1880MHz) –QPSK	Test Range	-30°C ~+50°C

Frequency Stability Under Temperature Variations

Temperature Interval(°C)	Test Frequency (GHz)	Deviation (kHz)	Limit (kHz)
-30	1.88	-0.0094	±4.70
-20	1.88	-0.0091	±4.70
-10	1.88	-0.0070	±4.70
0	1.88	-0.0099	±4.70
10	1.88	-0.0086	±4.70
20	1.88	-0.0088	±4.70
30	1.88	-0.0081	±4.70
40	1.88	0.0070	±4.70
50	1.88	-0.0076	±4.70

Voltage Variations

DC Voltage (V)	Test Frequency (GHz)	Deviation (kHz)	Limit (kHz)
13.8	1.88	-0.0081	±4.70
12	1.88	-0.0088	±4.70
10.2	1.88	-0.0082	±4.70

Product	DCM (Data Communication Module)		
Test Mode	Frequency Stability Under Temperature Variations & Voltage Variations		
Date of Test	2017/11/17	Test Site	CTR
Test Condition	Band 2 (3M) CH18900(1880MHz) -16QAM	Test Range	-30°C ~+50°C

Frequency Stability Under Temperature Variations

Temperature Interval(°C)	Test Frequency (GHz)	Deviation (kHz)	Limit (kHz)
-30	1.88	-0.0114	±4.70
-20	1.88	-0.0083	±4.70
-10	1.88	-0.0070	±4.70
0	1.88	-0.0080	±4.70
10	1.88	-0.0082	±4.70
20	1.88	-0.0088	±4.70
30	1.88	-0.0082	±4.70
40	1.88	-0.0085	±4.70
50	1.88	-0.0080	±4.70

Voltage Variations

DC Voltage (V)	Test Frequency (GHz)	Deviation (kHz)	Limit (kHz)
13.8	1.88	-0.0075	±4.70
12	1.88	-0.0088	±4.70
10.2	1.88	-0.0090	±4.70

Product	DCM (Data Communication Module)		
Test Mode	Frequency Stability Under Temperature Variations & Voltage Variations		
Date of Test	2017/11/17	Test Site	CTR
Test Condition	Band 2 (5M) CH18900(1880MHz) –QPSK	Test Range	-30°C ~+50°C

Frequency Stability Under Temperature Variations

Temperature Interval(°C)	Test Frequency (GHz)	Deviation (kHz)	Limit (kHz)
-30	1.88	-0.0111	±4.70
-20	1.88	-0.0101	±4.70
-10	1.88	-0.0110	±4.70
0	1.88	-0.0071	±4.70
10	1.88	-0.0069	±4.70
20	1.88	-0.0086	±4.70
30	1.88	-0.0066	±4.70
40	1.88	-0.0076	±4.70
50	1.88	-0.0072	±4.70

Voltage Variations

DC Voltage (V)	Test Frequency (GHz)	Deviation (kHz)	Limit (kHz)
13.8	1.88	-0.0079	±4.70
12	1.88	-0.0086	±4.70
10.2	1.88	-0.0092	±4.70

Product	DCM (Data Communication Module)		
Test Mode	Frequency Stability Under Temperature Variations & Voltage Variations		
Date of Test	2017/11/17	Test Site	CTR
Test Condition	Band 2 (5M) CH18900(1880MHz) –16QAM	Test Range	-30°C ~+50°C

Frequency Stability Under Temperature Variations

Temperature Interval(°C)	Test Frequency (GHz)	Deviation (kHz)	Limit (kHz)
-30	1.88	-0.0088	±4.70
-20	1.88	-0.0107	±4.70
-10	1.88	-0.0100	±4.70
0	1.88	-0.0087	±4.70
10	1.88	-0.0074	±4.70
20	1.88	-0.0076	±4.70
30	1.88	-0.0063	±4.70
40	1.88	-0.0081	±4.70
50	1.88	-0.0077	±4.70

Voltage Variations

DC Voltage (V)	Test Frequency (GHz)	Deviation (kHz)	Limit (kHz)
13.8	1.88	-0.0076	±4.70
12	1.88	-0.0076	±4.70
10.2	1.88	-0.0085	±4.70

Product	DCM (Data Communication Module)		
Test Mode	Frequency Stability Under Temperature Variations & Voltage Variations		
Date of Test	2017/11/17	Test Site	CTR
Test Condition	Band 2 (10M) CH18900(1880MHz) -QPSK	Test Range	-30°C ~+50°C

Frequency Stability Under Temperature Variations

Temperature Interval(°C)	Test Frequency (GHz)	Deviation (kHz)	Limit (kHz)
-30	1.88	-0.0087	±4.70
-20	1.88	-0.0080	±4.70
-10	1.88	-0.0075	±4.70
0	1.88	-0.0091	±4.70
10	1.88	-0.0092	±4.70
20	1.88	-0.0086	±4.70
30	1.88	-0.0080	±4.70
40	1.88	-0.0093	±4.70
50	1.88	-0.0088	±4.70

Voltage Variations

DC Voltage (V)	Test Frequency (GHz)	Deviation (kHz)	Limit (kHz)
13.8	1.88	-0.0087	±4.70
12	1.88	-0.0086	±4.70
10.2	1.88	-0.0082	±4.70

Product	DCM (Data Communication Module)		
Test Mode	Frequency Stability Under Temperature Variations & Voltage Variations		
Date of Test	2017/11/17	Test Site	CTR
Test Condition	Band 2 (10M) CH18900(1880MHz) -16QAM	Test Range	-30°C ~+50°C

Frequency Stability Under Temperature Variations

Temperature Interval(°C)	Test Frequency (GHz)	Deviation (kHz)	Limit (kHz)
-30	1.88	-0.0083	±4.70
-20	1.88	-0.0079	±4.70
-10	1.88	-0.0089	±4.70
0	1.88	-0.0103	±4.70
10	1.88	-0.0096	±4.70
20	1.88	-0.0083	±4.70
30	1.88	-0.0083	±4.70
40	1.88	-0.0080	±4.70
50	1.88	-0.0082	±4.70

Voltage Variations

DC Voltage (V)	Test Frequency (GHz)	Deviation (kHz)	Limit (kHz)
13.8	1.88	-0.0071	±4.70
12	1.88	-0.0083	±4.70
10.2	1.88	-0.0067	±4.70

Product	DCM (Data Communication Module)		
Test Mode	Frequency Stability Under Temperature Variations & Voltage Variations		
Date of Test	2017/11/17	Test Site	CTR
Test Condition	Band 2 (15M) CH18900(1880MHz) -QPSK	Test Range	-30°C ~+50°C

Frequency Stability Under Temperature Variations

Temperature Interval(°C)	Test Frequency (GHz)	Deviation (kHz)	Limit (kHz)
-30	1.88	-0.0067	±4.70
-20	1.88	-0.0063	±4.70
-10	1.88	-0.0096	±4.70
0	1.88	-0.0066	±4.70
10	1.88	-0.0060	±4.70
20	1.88	-0.0088	±4.70
30	1.88	-0.0084	±4.70
40	1.88	0.0096	±4.70
50	1.88	-0.0069	±4.70

Voltage Variations

DC Voltage (V)	Test Frequency (GHz)	Deviation (kHz)	Limit (kHz)
13.8	1.88	-0.0089	±4.70
12	1.88	-0.0088	±4.70
10.2	1.88	-0.0083	±4.70

Product	DCM (Data Communication Module)		
Test Mode	Frequency Stability Under Temperature Variations & Voltage Variations		
Date of Test	2017/11/17	Test Site	CTR
Test Condition	Band 2 (15M) CH18900(1880MHz) -16QAM	Test Range	-30°C ~+50°C

Frequency Stability Under Temperature Variations

Temperature Interval(°C)	Test Frequency (GHz)	Deviation (kHz)	Limit (kHz)
-30	1.88	-0.0071	±4.70
-20	1.88	-0.0071	±4.70
-10	1.88	-0.0075	±4.70
0	1.88	-0.0065	±4.70
10	1.88	-0.0066	±4.70
20	1.88	-0.0081	±4.70
30	1.88	-0.0082	±4.70
40	1.88	0.0099	±4.70
50	1.88	-0.0089	±4.70

Voltage Variations

DC Voltage (V)	Test Frequency (GHz)	Deviation (kHz)	Limit (kHz)
13.8	1.88	-0.0091	±4.70
12	1.88	-0.0081	±4.70
10.2	1.88	-0.0080	±4.70

Product	DCM (Data Communication Module)		
Test Mode	Frequency Stability Under Temperature Variations & Voltage Variations		
Date of Test	2017/11/17	Test Site	CTR
Test Condition	Band 2 (20M) CH18900(1880MHz) -QPSK	Test Range	-30°C ~+50°C

Frequency Stability Under Temperature Variations

Temperature Interval(°C)	Test Frequency (GHz)	Deviation (kHz)	Limit (kHz)
-30	1.88	-0.0092	±4.70
-20	1.88	-0.0077	±4.70
-10	1.88	-0.0086	±4.70
0	1.88	-0.0063	±4.70
10	1.88	-0.0058	±4.70
20	1.88	-0.0089	±4.70
30	1.88	-0.0087	±4.70
40	1.88	-0.0088	±4.70
50	1.88	-0.0073	±4.70

Voltage Variations

DC Voltage (V)	Test Frequency (GHz)	Deviation (kHz)	Limit (kHz)
13.8	1.88	-0.0069	±4.70
12	1.88	-0.0089	±4.70
10.2	1.88	-0.0077	±4.70

Product	DCM (Data Communication Module)		
Test Mode	Frequency Stability Under Temperature Variations & Voltage Variations		
Date of Test	2017/11/17	Test Site	CTR
Test Condition	Band 2 (20M) CH18900(1880MHz) -16QAM	Test Range	-30°C ~+50°C

Frequency Stability Under Temperature Variations

Temperature Interval(°C)	Test Frequency (GHz)	Deviation (kHz)	Limit (kHz)
-30	1.88	-0.0084	±4.70
-20	1.88	-0.0091	±4.70
-10	1.88	-0.0062	±4.70
0	1.88	-0.0061	±4.70
10	1.88	-0.0070	±4.70
20	1.88	-0.0084	±4.70
30	1.88	-0.0088	±4.70
40	1.88	-0.0064	±4.70
50	1.88	-0.0074	±4.70

Voltage Variations

DC Voltage (V)	Test Frequency (GHz)	Deviation (kHz)	Limit (kHz)
13.8	1.88	-0.0068	±4.70
12	1.88	-0.0084	±4.70
10.2	1.88	-0.0077	±4.70

Product	DCM (Data Communication Module)		
Test Mode	Frequency Stability Under Temperature Variations & Voltage Variations		
Date of Test	2017/11/17	Test Site	CTR
Test Condition	Band 4 (1.4M) CH20175(1732.5MHz) –QPSK	Test Range	-30°C ~+50°C

Frequency Stability Under Temperature Variations

Temperature Interval(°C)	Test Frequency (GHz)	Deviation (kHz)	Limit (kHz)
-30	1.73	-0.0039	±4.33
-20	1.73	0.0060	±4.33
-10	1.73	0.0041	±4.33
0	1.73	0.0053	±4.33
10	1.73	0.0054	±4.33
20	1.73	0.0051	±4.33
30	1.73	0.0044	±4.33
40	1.73	-0.0046	±4.33
50	1.73	0.0052	±4.33

Voltage Variations

DC Voltage (V)	Test Frequency (GHz)	Deviation (kHz)	Limit (kHz)
13.8	1.73	0.0049	±4.33
12	1.73	0.0051	±4.33
10.2	1.73	-0.0055	±4.33

Product	DCM (Data Communication Module)		
Test Mode	Frequency Stability Under Temperature Variations & Voltage Variations		
Date of Test	2017/11/17	Test Site	CTR
Test Condition	Band 4 (1.4M) CH20175(1732.5MHz) –16QAM	Test Range	-30°C ~+50°C

Frequency Stability Under Temperature Variations

Temperature Interval(°C)	Test Frequency (GHz)	Deviation (kHz)	Limit (kHz)
-30	1.73	-0.0040	±4.33
-20	1.73	-0.0047	±4.33
-10	1.73	0.0040	±4.33
0	1.73	-0.0038	±4.33
10	1.73	0.0052	±4.33
20	1.73	-0.0075	±4.33
30	1.73	0.0051	±4.33
40	1.73	-0.0082	±4.33
50	1.73	-0.0084	±4.33

Voltage Variations

DC Voltage (V)	Test Frequency (GHz)	Deviation (kHz)	Limit (kHz)
13.8	1.73	-0.0049	±4.33
12	1.73	-0.0075	±4.33
10.2	1.73	-0.0060	±4.33

Product	DCM (Data Communication Module)		
Test Mode	Frequency Stability Under Temperature Variations & Voltage Variations		
Date of Test	2017/11/17	Test Site	CTR
Test Condition	Band 4 (3M) CH20175(1732.5MHz) –QPSK	Test Range	-30°C ~+50°C

Frequency Stability Under Temperature Variations

Temperature Interval(°C)	Test Frequency (GHz)	Deviation (kHz)	Limit (kHz)
-30	1.73	-0.0046	±4.33
-20	1.73	-0.0062	±4.33
-10	1.73	0.0046	±4.33
0	1.73	0.0070	±4.33
10	1.73	0.0059	±4.33
20	1.73	-0.0055	±4.33
30	1.73	0.0043	±4.33
40	1.73	0.0046	±4.33
50	1.73	0.0035	±4.33

Voltage Variations

DC Voltage (V)	Test Frequency (GHz)	Deviation (kHz)	Limit (kHz)
13.8	1.73	-0.0049	±4.33
12	1.73	-0.0055	±4.33
10.2	1.73	-0.0041	±4.33

Product	DCM (Data Communication Module)		
Test Mode	Frequency Stability Under Temperature Variations & Voltage Variations		
Date of Test	2017/11/17	Test Site	CTR
Test Condition	Band 4 (3M) CH20175(1732.5MHz) -16QAM	Test Range	-30°C ~+50°C

Frequency Stability Under Temperature Variations

Temperature Interval(°C)	Test Frequency (GHz)	Deviation (kHz)	Limit (kHz)
-30	1.73	0.0066	±4.33
-20	1.73	-0.0065	±4.33
-10	1.73	0.0052	±4.33
0	1.73	0.0059	±4.33
10	1.73	0.0057	±4.33
20	1.73	-0.0060	±4.33
30	1.73	-0.0056	±4.33
40	1.73	0.0051	±4.33
50	1.73	0.0052	±4.33

Voltage Variations

DC Voltage (V)	Test Frequency (GHz)	Deviation (kHz)	Limit (kHz)
13.8	1.73	-0.0062	±4.33
12	1.73	-0.0060	±4.33
10.2	1.73	0.0052	±4.33

Product	DCM (Data Communication Module)		
Test Mode	Frequency Stability Under Temperature Variations & Voltage Variations		
Date of Test	2017/11/17	Test Site	CTR
Test Condition	Band 4 (5M) CH20175(1732.5MHz) –QPSK	Test Range	-30°C ~+50°C

Frequency Stability Under Temperature Variations

Temperature Interval(°C)	Test Frequency (GHz)	Deviation (kHz)	Limit (kHz)
-30	1.73	0.0055	±4.33
-20	1.73	-0.0064	±4.33
-10	1.73	0.0054	±4.33
0	1.73	0.0062	±4.33
10	1.73	0.0057	±4.33
20	1.73	0.0050	±4.33
30	1.73	0.0047	±4.33
40	1.73	0.0045	±4.33
50	1.73	0.0048	±4.33

Voltage Variations

DC Voltage (V)	Test Frequency (GHz)	Deviation (kHz)	Limit (kHz)
13.8	1.73	0.0053	±4.33
12	1.73	0.0050	±4.33
10.2	1.73	-0.0042	±4.33

Product	DCM (Data Communication Module)		
Test Mode	Frequency Stability Under Temperature Variations & Voltage Variations		
Date of Test	2017/11/17	Test Site	CTR
Test Condition	Band 4 (5M) CH20175(1732.5MHz) –16QAM	Test Range	-30°C ~+50°C

Frequency Stability Under Temperature Variations

Temperature Interval(°C)	Test Frequency (GHz)	Deviation (kHz)	Limit (kHz)
-30	1.73	0.0071	±4.33
-20	1.73	-0.0064	±4.33
-10	1.73	0.0070	±4.33
0	1.73	0.0057	±4.33
10	1.73	0.0065	±4.33
20	1.73	-0.0049	±4.33
30	1.73	-0.0049	±4.33
40	1.73	-0.0061	±4.33
50	1.73	0.0044	±4.33

Voltage Variations

DC Voltage (V)	Test Frequency (GHz)	Deviation (kHz)	Limit (kHz)
13.8	1.73	0.0050	±4.33
12	1.73	-0.0049	±4.33
10.2	1.73	0.0057	±4.33

Product	DCM (Data Communication Module)		
Test Mode	Frequency Stability Under Temperature Variations & Voltage Variations		
Date of Test	2017/11/17	Test Site	CTR
Test Condition	Band 4 (10M) CH20175(1732.5MHz)-QPSK	Test Range	-30°C ~+50°C

Frequency Stability Under Temperature Variations

Temperature Interval(°C)	Test Frequency (GHz)	Deviation (kHz)	Limit (kHz)
-30	1.73	-0.0048	±4.33
-20	1.73	0.0056	±4.33
-10	1.73	0.0048	±4.33
0	1.73	0.0053	±4.33
10	1.73	0.0049	±4.33
20	1.73	0.0051	±4.33
30	1.73	-0.0043	±4.33
40	1.73	-0.0036	±4.33
50	1.73	0.0041	±4.33

Voltage Variations

DC Voltage (V)	Test Frequency (GHz)	Deviation (kHz)	Limit (kHz)
13.8	1.73	0.0049	±4.33
12	1.73	0.0051	±4.33
10.2	1.73	0.0042	±4.33

Product	DCM (Data Communication Module)		
Test Mode	Frequency Stability Under Temperature Variations & Voltage Variations		
Date of Test	2017/11/17	Test Site	CTR
Test Condition	Band 4 (10M) CH20175(1732.5MHz)-16QAM	Test Range	-30°C ~+50°C

Frequency Stability Under Temperature Variations

Temperature Interval(°C)	Test Frequency (GHz)	Deviation (kHz)	Limit (kHz)
-30	1.73	-0.0062	±4.33
-20	1.73	0.0058	±4.33
-10	1.73	-0.0044	±4.33
0	1.73	0.0050	±4.33
10	1.73	0.0043	±4.33
20	1.73	-0.0052	±4.33
30	1.73	-0.0048	±4.33
40	1.73	0.0050	±4.33
50	1.73	0.0060	±4.33

Voltage Variations

DC Voltage (V)	Test Frequency (GHz)	Deviation (kHz)	Limit (kHz)
13.8	1.73	-0.0054	±4.33
12	1.73	-0.0052	±4.33
10.2	1.73	-0.0042	±4.33

Product	DCM (Data Communication Module)		
Test Mode	Frequency Stability Under Temperature Variations & Voltage Variations		
Date of Test	2017/11/17	Test Site	CTR
Test Condition	Band 4 (15M) CH20175(1732.5MHz)-QPSK	Test Range	-30°C ~+50°C

Frequency Stability Under Temperature Variations

Temperature Interval(°C)	Test Frequency (GHz)	Deviation (kHz)	Limit (kHz)
-30	1.73	-0.0049	±4.33
-20	1.73	0.0044	±4.33
-10	1.73	0.0053	±4.33
0	1.73	0.0053	±4.33
10	1.73	0.0054	±4.33
20	1.73	-0.0050	±4.33
30	1.73	-0.0037	±4.33
40	1.73	0.0054	±4.33
50	1.73	0.0047	±4.33

Voltage Variations

DC Voltage (V)	Test Frequency (GHz)	Deviation (kHz)	Limit (kHz)
13.8	1.73	0.0047	±4.33
12	1.73	-0.0050	±4.33
10.2	1.73	0.0056	±4.33

Product	DCM (Data Communication Module)		
Test Mode	Frequency Stability Under Temperature Variations & Voltage Variations		
Date of Test	2017/11/17	Test Site	CTR
Test Condition	Band 4 (15M) CH20175(1732.5MHz)-16QAM	Test Range	-30°C ~+50°C

Frequency Stability Under Temperature Variations

Temperature Interval(°C)	Test Frequency (GHz)	Deviation (kHz)	Limit (kHz)
-30	1.73	-0.0054	±4.33
-20	1.73	0.0042	±4.33
-10	1.73	0.0048	±4.33
0	1.73	0.0049	±4.33
10	1.73	0.0056	±4.33
20	1.73	-0.0049	±4.33
30	1.73	0.0060	±4.33
40	1.73	0.0062	±4.33
50	1.73	0.0080	±4.33

Voltage Variations

DC Voltage (V)	Test Frequency (GHz)	Deviation (kHz)	Limit (kHz)
13.8	1.73	0.0055	±4.33
12	1.73	-0.0049	±4.33
10.2	1.73	0.0050	±4.33

Product	DCM (Data Communication Module)		
Test Mode	Frequency Stability Under Temperature Variations & Voltage Variations		
Date of Test	2017/11/17	Test Site	CTR
Test Condition	Band 4 (20M) CH20175(1732.5MHz)-QPSK	Test Range	-30°C ~+50°C

Frequency Stability Under Temperature Variations

Temperature Interval(°C)	Test Frequency (GHz)	Deviation (kHz)	Limit (kHz)
-30	1.73	0.0039	±4.33
-20	1.73	-0.0056	±4.33
-10	1.73	0.0057	±4.33
0	1.73	0.0062	±4.33
10	1.73	0.0056	±4.33
20	1.73	-0.0049	±4.33
30	1.73	0.0040	±4.33
40	1.73	0.0042	±4.33
50	1.73	0.0040	±4.33

Voltage Variations

DC Voltage (V)	Test Frequency (GHz)	Deviation (kHz)	Limit (kHz)
13.8	1.73	-0.0044	±4.33
12	1.73	-0.0049	±4.33
10.2	1.73	-0.0039	±4.33

Product	DCM (Data Communication Module)		
Test Mode	Frequency Stability Under Temperature Variations & Voltage Variations		
Date of Test	2017/11/17	Test Site	CTR
Test Condition	Band 4 (20M) CH20175(1732.5MHz)-16QAM	Test Range	-30°C~+50°C

Frequency Stability Under Temperature Variations

Temperature Interval(°C)	Test Frequency (GHz)	Deviation (kHz)	Limit (kHz)
-30	1.73	-0.0043	±4.33
-20	1.73	0.0059	±4.33
-10	1.73	0.0055	±4.33
0	1.73	0.0041	±4.33
10	1.73	0.0048	±4.33
20	1.73	0.0051	±4.33
30	1.73	0.0047	±4.33
40	1.73	0.0043	±4.33
50	1.73	-0.0044	±4.33

Voltage Variations

DC Voltage (V)	Test Frequency (GHz)	Deviation (kHz)	Limit (kHz)
13.8	1.73	0.0049	±4.33
12	1.73	0.0051	±4.33
10.2	1.73	-0.0040	±4.33

Product	DCM (Data Communication Module)		
Test Mode	Frequency Stability Under Temperature Variations & Voltage Variations		
Date of Test	2017/11/17	Test Site	CTR
Test Condition	Band 5 (1.4M) CH20525(836.5MHz)-QPSK	Test Range	-30°C ~+50°C

Frequency Stability Under Temperature Variations

Temperature Interval(°C)	Test Frequency (GHz)	Deviation (kHz)	Limit (kHz)
-30	0.8365	-0.0043	±2.09
-20	0.8365	-0.0038	±2.09
-10	0.8365	0.0031	±2.09
0	0.8365	0.0039	±2.09
10	0.8365	0.0036	±2.09
20	0.8365	-0.0039	±2.09
30	0.8365	-0.0040	±2.09
40	0.8365	-0.0042	±2.09
50	0.8365	0.0036	±2.09

Voltage Variations

DC Voltage (V)	Test Frequency (GHz)	Deviation (kHz)	Limit (kHz)
13.8	0.8365	0.0034	±2.09
12	0.8365	-0.0039	±2.09
10.2	0.8365	-0.0036	±2.09

Product	DCM (Data Communication Module)		
Test Mode	Frequency Stability Under Temperature Variations & Voltage Variations		
Date of Test	2017/11/17	Test Site	CTR
Test Condition	Band 5 (1.4M) CH20525(836.5MHz)-16QAM	Test Range	-30°C ~+50°C

Frequency Stability Under Temperature Variations

Temperature Interval(°C)	Test Frequency (GHz)	Deviation (kHz)	Limit (kHz)
-30	0.8365	-0.0049	±2.09
-20	0.8365	-0.0043	±2.09
-10	0.8365	0.0034	±2.09
0	0.8365	0.0036	±2.09
10	0.8365	0.0041	±2.09
20	0.8365	-0.0047	±2.09
30	0.8365	-0.0036	±2.09
40	0.8365	-0.0039	±2.09
50	0.8365	-0.0031	±2.09

Voltage Variations

DC Voltage (V)	Test Frequency (GHz)	Deviation (kHz)	Limit (kHz)
13.8	0.8365	-0.0043	±2.09
12	0.8365	-0.0047	±2.09
10.2	0.8365	-0.0044	±2.09

Product	DCM (Data Communication Module)		
Test Mode	Frequency Stability Under Temperature Variations & Voltage Variations		
Date of Test	2017/11/17	Test Site	CTR
Test Condition	Band 5 (3M) CH20525(836.5MHz)-QPSK	Test Range	-30°C ~+50°C

Frequency Stability Under Temperature Variations

Temperature Interval(°C)	Test Frequency (GHz)	Deviation (kHz)	Limit (kHz)
-30	0.8365	-0.0047	±2.09
-20	0.8365	-0.0037	±2.09
-10	0.8365	0.0046	±2.09
0	0.8365	0.0044	±2.09
10	0.8365	0.0057	±2.09
20	0.8365	0.0034	±2.09
30	0.8365	-0.0038	±2.09
40	0.8365	-0.0040	±2.09
50	0.8365	-0.0030	±2.09

Voltage Variations

DC Voltage (V)	Test Frequency (GHz)	Deviation (kHz)	Limit (kHz)
13.8	0.8365	-0.0036	±2.09
12	0.8365	0.0034	±2.09
10.2	0.8365	-0.0040	±2.09

Product	DCM (Data Communication Module)		
Test Mode	Frequency Stability Under Temperature Variations & Voltage Variations		
Date of Test	2017/11/17	Test Site	CTR
Test Condition	Band 5 (3M) CH20525(836.5MHz)-16QAM	Test Range	-30°C ~+50°C

Frequency Stability Under Temperature Variations

Temperature Interval(°C)	Test Frequency (GHz)	Deviation (kHz)	Limit (kHz)
-30	0.8365	-0.0039	±2.09
-20	0.8365	-0.0045	±2.09
-10	0.8365	0.0041	±2.09
0	0.8365	0.0046	±2.09
10	0.8365	-0.0036	±2.09
20	0.8365	-0.0038	±2.09
30	0.8365	-0.0043	±2.09
40	0.8365	-0.0034	±2.09
50	0.8365	-0.0033	±2.09

Voltage Variations

DC Voltage (V)	Test Frequency (GHz)	Deviation (kHz)	Limit (kHz)
13.8	0.8365	-0.0038	±2.09
12	0.8365	-0.0038	±2.09
10.2	0.8365	-0.0031	±2.09

Product	DCM (Data Communication Module)		
Test Mode	Frequency Stability Under Temperature Variations & Voltage Variations		
Date of Test	2017/11/17	Test Site	CTR
Test Condition	Band 5 (5M) CH20525(836.5MHz)-QPSK	Test Range	-30°C ~+50°C

Frequency Stability Under Temperature Variations

Temperature Interval(°C)	Test Frequency (GHz)	Deviation (kHz)	Limit (kHz)
-30	0.8365	-0.0034	±2.09
-20	0.8365	-0.0038	±2.09
-10	0.8365	-0.0031	±2.09
0	0.8365	0.0030	±2.09
10	0.8365	0.0035	±2.09
20	0.8365	-0.0035	±2.09
30	0.8365	0.0026	±2.09
40	0.8365	-0.0032	±2.09
50	0.8365	-0.0038	±2.09

Voltage Variations

DC Voltage (V)	Test Frequency (GHz)	Deviation (kHz)	Limit (kHz)
13.8	0.8365	-0.0032	±2.09
12	0.8365	-0.0035	±2.09
10.2	0.8365	0.0020	±2.09

Product	DCM (Data Communication Module)		
Test Mode	Frequency Stability Under Temperature Variations & Voltage Variations		
Date of Test	2017/11/17	Test Site	CTR
Test Condition	Band 5 (5M) CH20525(836.5MHz)-16QAM	Test Range	-30°C ~+50°C

Frequency Stability Under Temperature Variations

Temperature Interval(°C)	Test Frequency (GHz)	Deviation (kHz)	Limit (kHz)
-30	0.8365	-0.0028	±2.09
-20	0.8365	-0.0043	±2.09
-10	0.8365	0.0041	±2.09
0	0.8365	0.0027	±2.09
10	0.8365	0.0033	±2.09
20	0.8365	-0.0041	±2.09
30	0.8365	-0.0046	±2.09
40	0.8365	0.0058	±2.09
50	0.8365	0.0053	±2.09

Voltage Variations

DC Voltage (V)	Test Frequency (GHz)	Deviation (kHz)	Limit (kHz)
13.8	0.8365	-0.0037	±2.09
12	0.8365	-0.0041	±2.09
10.2	0.8365	-0.0035	±2.09

Product	DCM (Data Communication Module)		
Test Mode	Frequency Stability Under Temperature Variations & Voltage Variations		
Date of Test	2017/11/17	Test Site	CTR
Test Condition	Band 5 (10M) CH20525(836.5MHz)-QPSK	Test Range	-30°C ~+50°C

Frequency Stability Under Temperature Variations

Temperature Interval(°C)	Test Frequency (GHz)	Deviation (kHz)	Limit (kHz)
-30	0.8365	-0.0040	±2.09
-20	0.8365	-0.0053	±2.09
-10	0.8365	0.0039	±2.09
0	0.8365	0.0039	±2.09
10	0.8365	-0.0050	±2.09
20	0.8365	-0.0047	±2.09
30	0.8365	-0.0031	±2.09
40	0.8365	-0.0039	±2.09
50	0.8365	-0.0032	±2.09

Voltage Variations

DC Voltage (V)	Test Frequency (GHz)	Deviation (kHz)	Limit (kHz)
13.8	0.8365	-0.0039	±2.09
12	0.8365	-0.0047	±2.09
10.2	0.8365	-0.0030	±2.09

Product	DCM (Data Communication Module)		
Test Mode	Frequency Stability Under Temperature Variations & Voltage Variations		
Date of Test	2017/11/17	Test Site	CTR
Test Condition	Band 5 (10M) CH20525(836.5MHz)-16QAM	Test Range	-30°C ~+50°C

Frequency Stability Under Temperature Variations

Temperature Interval(°C)	Test Frequency (GHz)	Deviation (kHz)	Limit (kHz)
-30	0.8365	-0.0043	±2.09
-20	0.8365	-0.0040	±2.09
-10	0.8365	-0.0049	±2.09
0	0.8365	0.0032	±2.09
10	0.8365	0.0047	±2.09
20	0.8365	-0.0042	±2.09
30	0.8365	-0.0024	±2.09
40	0.8365	-0.0035	±2.09
50	0.8365	-0.0052	±2.09

Voltage Variations

DC Voltage (V)	Test Frequency (GHz)	Deviation (kHz)	Limit (kHz)
13.8	0.8365	-0.0030	±2.09
12	0.8365	-0.0042	±2.09
10.2	0.8365	-0.0036	±2.09

Product	DCM (Data Communication Module)		
Test Mode	Frequency Stability Under Temperature Variations & Voltage Variations		
Date of Test	2017/11/17	Test Site	CTR
Test Condition	Band 17 (5M) CH23790(710MHz)-QPSK	Test Range	-30°C ~+50°C

Frequency Stability Under Temperature Variations

Temperature Interval(°C)	Test Frequency (GHz)	Deviation (KHz)	Limit (KHz)
-30	0.71	-0.0038	±1.78
-20	0.71	-0.0036	±1.78
-10	0.71	0.0040	±1.78
0	0.71	0.0050	±1.78
10	0.71	0.0041	±1.78
20	0.71	-0.0029	±1.78
30	0.71	-0.0028	±1.78
40	0.71	0.0037	±1.78
50	0.71	0.0041	±1.78

Voltage Variations

DC Voltage (V)	Test Frequency (GHz)	Deviation (KHz)	Limit (KHz)
13.8	0.71	0.0035	±1.78
12	0.71	-0.0029	±1.78
10.2	0.71	-0.0027	±1.78

Product	DCM (Data Communication Module)		
Test Mode	Frequency Stability Under Temperature Variations & Voltage Variations		
Date of Test	2017/11/17	Test Site	CTR
Test Condition	Band 17 (5M) CH23790(710MHz)-16QAM	Test Range	-30°C ~+50°C

Frequency Stability Under Temperature Variations

Temperature Interval(°C)	Test Frequency (GHz)	Deviation (KHz)	Limit (KHz)
-30	0.71	-0.0036	±1.78
-20	0.71	0.0033	±1.78
-10	0.71	0.0056	±1.78
0	0.71	0.0039	±1.78
10	0.71	0.0038	±1.78
20	0.71	-0.0044	±1.78
30	0.71	0.0039	±1.78
40	0.71	-0.0024	±1.78
50	0.71	0.0026	±1.78

Voltage Variations

DC Voltage (V)	Test Frequency (GHz)	Deviation (KHz)	Limit (KHz)
13.8	0.71	-0.0032	±1.78
12	0.71	-0.0044	±1.78
10.2	0.71	-0.0024	±1.78

Product	DCM (Data Communication Module)		
Test Mode	Frequency Stability Under Temperature Variations & Voltage Variations		
Date of Test	2017/11/17	Test Site	CTR
Test Condition	Band 17 (10M) CH23790(710MHz)-QPSK	Test Range	-30°C ~+50°C

Frequency Stability Under Temperature Variations

Temperature Interval(°C)	Test Frequency (GHz)	Deviation (KHz)	Limit (KHz)
-30	0.71	-0.0038	±1.78
-20	0.71	-0.0041	±1.78
-10	0.71	0.0035	±1.78
0	0.71	0.0055	±1.78
10	0.71	0.0053	±1.78
20	0.71	-0.0041	±1.78
30	0.71	0.0030	±1.78
40	0.71	0.0036	±1.78
50	0.71	0.0029	±1.78

Voltage Variations

DC Voltage (V)	Test Frequency (GHz)	Deviation (KHz)	Limit (KHz)
13.8	0.71	-0.0038	±1.78
12	0.71	-0.0041	±1.78
10.2	0.71	0.0029	±1.78

Product	DCM (Data Communication Module)		
Test Mode	Frequency Stability Under Temperature Variations & Voltage Variations		
Date of Test	2017/11/17	Test Site	CTR
Test Condition	Band 17 (10M) CH23790(710MHz)-16QAM	Test Range	-30°C ~+50°C

Frequency Stability Under Temperature Variations

Temperature Interval(°C)	Test Frequency (GHz)	Deviation (KHz)	Limit (KHz)
-30	0.71	-0.0031	±1.78
-20	0.71	0.0055	±1.78
-10	0.71	0.0041	±1.78
0	0.71	-0.0037	±1.78
10	0.71	0.0035	±1.78
20	0.71	-0.0037	±1.78
30	0.71	0.0032	±1.78
40	0.71	0.0031	±1.78
50	0.71	0.0032	±1.78

Voltage Variations

DC Voltage (V)	Test Frequency (GHz)	Deviation (KHz)	Limit (KHz)
13.8	0.71	-0.0024	±1.78
12	0.71	-0.0037	±1.78
10.2	0.71	-0.0030	±1.78

Product	DCM (Data Communication Module)		
Test Mode	Frequency Stability Under Temperature Variations & Voltage Variations		
Date of Test	2017/11/17	Test Site	CTR
Test Condition	Band 26 (1.4M) CH26915(836.5MHz)-QPSK	Test Range	-30°C ~+50°C

Frequency Stability Under Temperature Variations

Temperature Interval(°C)	Test Frequency (GHz)	Deviation (kHz)	Limit (kHz)
-30	0.8365	-0.0041	±2.09
-20	0.8365	0.0031	±2.09
-10	0.8365	-0.0039	±2.09
0	0.8365	-0.0030	±2.09
10	0.8365	0.0053	±2.09
20	0.8365	-0.0035	±2.09
30	0.8365	-0.0041	±2.09
40	0.8365	-0.0051	±2.09
50	0.8365	-0.0047	±2.09

Voltage Variations

DC Voltage (V)	Test Frequency (GHz)	Deviation (kHz)	Limit (kHz)
13.8	0.8365	-0.0043	±2.09
12	0.8365	-0.0035	±2.09
10.2	0.8365	-0.0040	±2.09

Product	DCM (Data Communication Module)		
Test Mode	Frequency Stability Under Temperature Variations & Voltage Variations		
Date of Test	2017/11/17	Test Site	CTR
Test Condition	Band 26 (1.4M) CH26915(836.5MHz)-16QAM	Test Range	-30°C ~+50°C

Frequency Stability Under Temperature Variations

Temperature Interval(°C)	Test Frequency (GHz)	Deviation (kHz)	Limit (kHz)
-30	0.8365	-0.0052	±2.09
-20	0.8365	-0.0046	±2.09
-10	0.8365	-0.0047	±2.09
0	0.8365	-0.0032	±2.09
10	0.8365	0.0049	±2.09
20	0.8365	0.0038	±2.09
30	0.8365	0.0033	±2.09
40	0.8365	-0.0035	±2.09
50	0.8365	-0.0044	±2.09

Voltage Variations

DC Voltage (V)	Test Frequency (GHz)	Deviation (kHz)	Limit (kHz)
13.8	0.8365	-0.0036	±2.09
12	0.8365	0.0038	±2.09
10.2	0.8365	0.0033	±2.09

Product	DCM (Data Communication Module)		
Test Mode	Frequency Stability Under Temperature Variations & Voltage Variations		
Date of Test	2017/11/17	Test Site	CTR
Test Condition	Band 26 (3M) CH26915(836.5MHz)-QPSK	Test Range	-30°C ~+50°C

Frequency Stability Under Temperature Variations

Temperature Interval(°C)	Test Frequency (GHz)	Deviation (kHz)	Limit (kHz)
-30	0.8365	-0.0041	±2.09
-20	0.8365	-0.0036	±2.09
-10	0.8365	0.0042	±2.09
0	0.8365	-0.0037	±2.09
10	0.8365	-0.0034	±2.09
20	0.8365	-0.0040	±2.09
30	0.8365	-0.0045	±2.09
40	0.8365	-0.0039	±2.09
50	0.8365	0.0048	±2.09

Voltage Variations

DC Voltage (V)	Test Frequency (GHz)	Deviation (kHz)	Limit (kHz)
13.8	0.8365	-0.0041	±2.09
12	0.8365	-0.0040	±2.09
10.2	0.8365	-0.0031	±2.09

Product	DCM (Data Communication Module)		
Test Mode	Frequency Stability Under Temperature Variations & Voltage Variations		
Date of Test	2017/11/17	Test Site	CTR
Test Condition	Band 26 (3M) CH26915(836.5MHz)-16QAM	Test Range	-30°C ~+50°C

Frequency Stability Under Temperature Variations

Temperature Interval(°C)	Test Frequency (GHz)	Deviation (kHz)	Limit (kHz)
-30	0.8365	-0.0056	±2.09
-20	0.8365	-0.0042	±2.09
-10	0.8365	-0.0036	±2.09
0	0.8365	-0.0038	±2.09
10	0.8365	-0.0027	±2.09
20	0.8365	0.0037	±2.09
30	0.8365	-0.0033	±2.09
40	0.8365	-0.0043	±2.09
50	0.8365	0.0048	±2.09

Voltage Variations

DC Voltage (V)	Test Frequency (GHz)	Deviation (kHz)	Limit (kHz)
13.8	0.8365	-0.0035	±2.09
12	0.8365	0.0037	±2.09
10.2	0.8365	-0.0030	±2.09

Product	DCM (Data Communication Module)		
Test Mode	Frequency Stability Under Temperature Variations & Voltage Variations		
Date of Test	2017/11/17	Test Site	CTR
Test Condition	Band 26 (5M) CH26915(836.5MHz)-QPSK	Test Range	-30°C ~+50°C

Frequency Stability Under Temperature Variations

Temperature Interval(°C)	Test Frequency (GHz)	Deviation (kHz)	Limit (kHz)
-30	0.8365	0.0050	±2.09
-20	0.8365	-0.0030	±2.09
-10	0.8365	-0.0058	±2.09
0	0.8365	-0.0040	±2.09
10	0.8365	-0.0055	±2.09
20	0.8365	-0.0054	±2.09
30	0.8365	-0.0042	±2.09
40	0.8365	-0.0055	±2.09
50	0.8365	-0.0060	±2.09

Voltage Variations

DC Voltage (V)	Test Frequency (GHz)	Deviation (kHz)	Limit (kHz)
13.8	0.8365	-0.0042	±2.09
12	0.8365	-0.0054	±2.09
10.2	0.8365	-0.0034	±2.09

Product	DCM (Data Communication Module)		
Test Mode	Frequency Stability Under Temperature Variations & Voltage Variations		
Date of Test	2017/11/17	Test Site	CTR
Test Condition	Band 26 (5M) CH26915(836.5MHz)-16QAM	Test Range	-30°C ~+50°C

Frequency Stability Under Temperature Variations

Temperature Interval(°C)	Test Frequency (GHz)	Deviation (kHz)	Limit (kHz)
-30	0.8365	-0.0058	±2.09
-20	0.8365	-0.0052	±2.09
-10	0.8365	-0.0050	±2.09
0	0.8365	-0.0042	±2.09
10	0.8365	0.0043	±2.09
20	0.8365	-0.0035	±2.09
30	0.8365	-0.0041	±2.09
40	0.8365	-0.0051	±2.09
50	0.8365	-0.0049	±2.09

Voltage Variations

DC Voltage (V)	Test Frequency (GHz)	Deviation (KHz)	Limit (KHz)
13.8	0.8365	-0.0038	±2.09
12	0.8365	-0.0035	±2.09
10.2	0.8365	-0.0040	±2.09

Product	DCM (Data Communication Module)		
Test Mode	Frequency Stability Under Temperature Variations & Voltage Variations		
Date of Test	2017/11/17	Test Site	CTR
Test Condition	Band 26 (10M) CH26915(836.5MHz)-QPSK	Test Range	-30°C ~+50°C

Frequency Stability Under Temperature Variations

Temperature Interval(°C)	Test Frequency (GHz)	Deviation (kHz)	Limit (kHz)
-30	0.8365	-0.0037	±2.09
-20	0.8365	-0.0050	±2.09
-10	0.8365	-0.0041	±2.09
0	0.8365	-0.0036	±2.09
10	0.8365	-0.0050	±2.09
20	0.8365	-0.0046	±2.09
30	0.8365	-0.0039	±2.09
40	0.8365	0.0044	±2.09
50	0.8365	-0.0044	±2.09

Voltage Variations

DC Voltage (V)	Test Frequency (GHz)	Deviation (KHz)	Limit (KHz)
13.8	0.8365	-0.0047	±2.09
12	0.8365	-0.0046	±2.09
10.2	0.8365	-0.0039	±2.09

Product	DCM (Data Communication Module)		
Test Mode	Frequency Stability Under Temperature Variations & Voltage Variations		
Date of Test	2017/11/17	Test Site	CTR
Test Condition	Band 26 (10M) CH26915(836.5MHz)-16QAM	Test Range	-30°C ~+50°C

Frequency Stability Under Temperature Variations

Temperature Interval(°C)	Test Frequency (GHz)	Deviation (kHz)	Limit (kHz)
-30	0.8365	-0.0042	±2.09
-20	0.8365	-0.0039	±2.09
-10	0.8365	-0.0044	±2.09
0	0.8365	-0.0039	±2.09
10	0.8365	-0.0035	±2.09
20	0.8365	0.0047	±2.09
30	0.8365	-0.0033	±2.09
40	0.8365	-0.0044	±2.09
50	0.8365	-0.0048	±2.09

Voltage Variations

DC Voltage (V)	Test Frequency (GHz)	Deviation (kHz)	Limit (kHz)
13.8	0.8365	-0.0039	±2.09
12	0.8365	0.0047	±2.09
10.2	0.8365	0.0041	±2.09

Product	DCM (Data Communication Module)		
Test Mode	Frequency Stability Under Temperature Variations & Voltage Variations		
Date of Test	2017/11/17	Test Site	CTR
Test Condition	Band 26 (15M) CH26915(836.5MHz)-QPSK	Test Range	-30°C ~+50°C

Frequency Stability Under Temperature Variations

Temperature Interval(°C)	Test Frequency (GHz)	Deviation (kHz)	Limit (kHz)
-30	0.8365	-0.0042	±2.09
-20	0.8365	0.0041	±2.09
-10	0.8365	-0.0040	±2.09
0	0.8365	-0.0039	±2.09
10	0.8365	0.0065	±2.09
20	0.8365	-0.0045	±2.09
30	0.8365	-0.0036	±2.09
40	0.8365	-0.0032	±2.09
50	0.8365	-0.0042	±2.09

Voltage Variations

DC Voltage (V)	Test Frequency (GHz)	Deviation (KHz)	Limit (KHz)
13.8	0.8365	0.0038	±2.09
12	0.8365	-0.0045	±2.09
10.2	0.8365	-0.0036	±2.09

Product	DCM (Data Communication Module)		
Test Mode	Frequency Stability Under Temperature Variations & Voltage Variations		
Date of Test	2017/11/17	Test Site	CTR
Test Condition	Band 26 (15M) CH26915(836.5MHz)-16QAM	Test Range	-30°C ~+50°C

Frequency Stability Under Temperature Variations

Temperature Interval(°C)	Test Frequency (GHz)	Deviation (kHz)	Limit (kHz)
-30	0.8365	-0.0041	±2.09
-20	0.8365	-0.0035	±2.09
-10	0.8365	0.0038	±2.09
0	0.8365	-0.0040	±2.09
10	0.8365	0.0036	±2.09
20	0.8365	-0.0040	±2.09
30	0.8365	-0.0032	±2.09
40	0.8365	-0.0043	±2.09
50	0.8365	-0.0038	±2.09

Voltage Variations

DC Voltage (V)	Test Frequency (GHz)	Deviation (kHz)	Limit (kHz)
13.8	0.8365	0.0043	±2.09
12	0.8365	-0.0040	±2.09
10.2	0.8365	-0.0042	±2.09

Product	DCM (Data Communication Module)		
Test Mode	Frequency Stability Under Temperature Variations & Voltage Variations		
Date of Test	2017/11/17	Test Site	CTR
Test Condition	Band 41 (5M) CH40620 (2593MHz) –QPSK	Test Range	-30°C ~+50°C

Frequency Stability Under Temperature Variations

Temperature Interval(°C)	Test Frequency (GHz)	Deviation (kHz)	Limit (kHz)
-30	2.593	0.0151	±6.48
-20	2.593	0.0184	±6.48
-10	2.593	0.0198	±6.48
0	2.593	0.0749	±6.48
10	2.593	0.0220	±6.48
20	2.593	0.0222	±6.48
30	2.593	0.0239	±6.48
40	2.593	0.0260	±6.48
50	2.593	0.0276	±6.48

Voltage Variations

DC Voltage (V)	Test Frequency (GHz)	Deviation (kHz)	Limit (kHz)
13.8	2.593	0.0225	±6.48
12	2.593	0.0222	±6.48
10.2	2.593	-0.0536	±6.48

Product	DCM (Data Communication Module)		
Test Mode	Frequency Stability Under Temperature Variations & Voltage Variations		
Date of Test	2017/11/17	Test Site	CTR
Test Condition	Band 41 (5M) CH40620 (2593MHz) –16QAM	Test Range	-30°C ~+50°C

Frequency Stability Under Temperature Variations

Temperature Interval(°C)	Test Frequency (GHz)	Deviation (kHz)	Limit (kHz)
-30	2.593	0.0143	±6.48
-20	2.593	0.0194	±6.48
-10	2.593	0.0239	±6.48
0	2.593	0.0689	±6.48
10	2.593	0.0213	±6.48
20	2.593	0.0184	±6.48
30	2.593	0.0260	±6.48
40	2.593	0.0257	±6.48
50	2.593	0.0278	±6.48

Voltage Variations

DC Voltage (V)	Test Frequency (GHz)	Deviation (kHz)	Limit (kHz)
13.8	2.593	0.0208	±6.48
12	2.593	0.0184	±6.48
10.2	2.593	-0.0607	±6.48

Product	DCM (Data Communication Module)		
Test Mode	Frequency Stability Under Temperature Variations & Voltage Variations		
Date of Test	2017/11/17	Test Site	CTR
Test Condition	Band 41 (10M) CH40620 (2593MHz)-QPSK	Test Range	-30°C ~+50°C

Frequency Stability Under Temperature Variations

Temperature Interval(°C)	Test Frequency (GHz)	Deviation (kHz)	Limit (kHz)
-30	2.593	0.0472	±6.48
-20	2.593	0.0357	±6.48
-10	2.593	0.0224	±6.48
0	2.593	0.0230	±6.48
10	2.593	0.0212	±6.48
20	2.593	0.0213	±6.48
30	2.593	0.0255	±6.48
40	2.593	0.0523	±6.48
50	2.593	-0.0486	±6.48

Voltage Variations

DC Voltage (V)	Test Frequency (GHz)	Deviation (kHz)	Limit (kHz)
13.8	2.593	0.0235	±6.48
12	2.593	0.0213	±6.48
10.2	2.593	0.0545	±6.48

Product	DCM (Data Communication Module)		
Test Mode	Frequency Stability Under Temperature Variations & Voltage Variations		
Date of Test	2017/11/17	Test Site	CTR
Test Condition	Band 41 (10M) CH40620 (2593MHz)-16QAM	Test Range	-30°C ~+50°C

Frequency Stability Under Temperature Variations

Temperature Interval(°C)	Test Frequency (GHz)	Deviation (kHz)	Limit (kHz)
-30	2.593	0.0653	±6.48
-20	2.593	-0.0593	±6.48
-10	2.593	0.0208	±6.48
0	2.593	0.0204	±6.48
10	2.593	0.0211	±6.48
20	2.593	0.0221	±6.48
30	2.593	0.0224	±6.48
40	2.593	0.0264	±6.48
50	2.593	0.0288	±6.48

Voltage Variations

DC Voltage (V)	Test Frequency (GHz)	Deviation (kHz)	Limit (kHz)
13.8	2.593	0.0213	±6.48
12	2.593	0.0221	±6.48
10.2	2.593	0.0207	±6.48

Product	DCM (Data Communication Module)		
Test Mode	Frequency Stability Under Temperature Variations & Voltage Variations		
Date of Test	2017/11/17	Test Site	CTR
Test Condition	Band 41 (15M) CH40620 (2593MHz)-QPSK	Test Range	-30°C ~+50°C

Frequency Stability Under Temperature Variations

Temperature Interval(°C)	Test Frequency (GHz)	Deviation (kHz)	Limit (kHz)
-30	2.593	0.0149	±6.48
-20	2.593	0.0175	±6.48
-10	2.593	0.0486	±6.48
0	2.593	0.0820	±6.48
10	2.593	0.0841	±6.48
20	2.593	0.0520	±6.48
30	2.593	0.0243	±6.48
40	2.593	0.0546	±6.48
50	2.593	0.0800	±6.48

Voltage Variations

DC Voltage (V)	Test Frequency (GHz)	Deviation (kHz)	Limit (kHz)
13.8	2.593	0.0222	±6.48
12	2.593	0.0520	±6.48
10.2	2.593	0.0548	±6.48

Product	DCM (Data Communication Module)		
Test Mode	Frequency Stability Under Temperature Variations & Voltage Variations		
Date of Test	2017/11/17	Test Site	CTR
Test Condition	Band 41 (15M) CH40620 (2593MHz)-16QAM	Test Range	-30°C ~+50°C

Frequency Stability Under Temperature Variations

Temperature Interval(°C)	Test Frequency (GHz)	Deviation (kHz)	Limit (kHz)
-30	2.593	0.0174	±6.48
-20	2.593	0.0188	±6.48
-10	2.593	0.0850	±6.48
0	2.593	0.0537	±6.48
10	2.593	0.0867	±6.48
20	2.593	0.0920	±6.48
30	2.593	0.0241	±6.48
40	2.593	0.0446	±6.48
50	2.593	0.0252	±6.48

Voltage Variations

DC Voltage (V)	Test Frequency (GHz)	Deviation (kHz)	Limit (kHz)
13.8	2.593	0.0232	±6.48
12	2.593	0.0920	±6.48
10.2	2.593	0.0825	±6.48

Product	DCM (Data Communication Module)		
Test Mode	Frequency Stability Under Temperature Variations & Voltage Variations		
Date of Test	2017/11/17	Test Site	CTR
Test Condition	Band 41 (20M) CH40620 (2593MHz)-QPSK	Test Range	-30°C ~+50°C

Frequency Stability Under Temperature Variations

Temperature Interval(°C)	Test Frequency (GHz)	Deviation (kHz)	Limit (kHz)
-30	2.593	0.0119	±6.48
-20	2.593	0.0155	±6.48
-10	2.593	0.0412	±6.48
0	2.593	0.0214	±6.48
10	2.593	0.0913	±6.48
20	2.593	0.0540	±6.48
30	2.593	0.0846	±6.48
40	2.593	0.0260	±6.48
50	2.593	0.0894	±6.48

Voltage Variations

DC Voltage (V)	Test Frequency (GHz)	Deviation (kHz)	Limit (kHz)
13.8	2.593	0.0543	±6.48
12	2.593	0.0540	±6.48
10.2	2.593	0.0481	±6.48

Product	DCM (Data Communication Module)		
Test Mode	Frequency Stability Under Temperature Variations & Voltage Variations		
Date of Test	2017/11/17	Test Site	CTR
Test Condition	Band 41 (20M) CH40620 (2593MHz)-16QAM	Test Range	-30°C ~+50°C

Frequency Stability Under Temperature Variations

Temperature Interval(°C)	Test Frequency (GHz)	Deviation (kHz)	Limit (kHz)
-30	2.593	0.0142	±6.48
-20	2.593	0.0161	±6.48
-10	2.593	0.0197	±6.48
0	2.593	0.0204	±6.48
10	2.593	0.0235	±6.48
20	2.593	0.0230	±6.48
30	2.593	0.0828	±6.48
40	2.593	0.0452	±6.48
50	2.593	0.0267	±6.48

Voltage Variations

DC Voltage (V)	Test Frequency (GHz)	Deviation (kHz)	Limit (kHz)
13.8	2.593	0.0215	±6.48
12	2.593	0.0230	±6.48
10.2	2.593	0.0248	±6.48

8. Peak to Average Ratio

8.1 Test Specification

According to Part 22.913, 24.232, 27.50

8.2 Test Setup

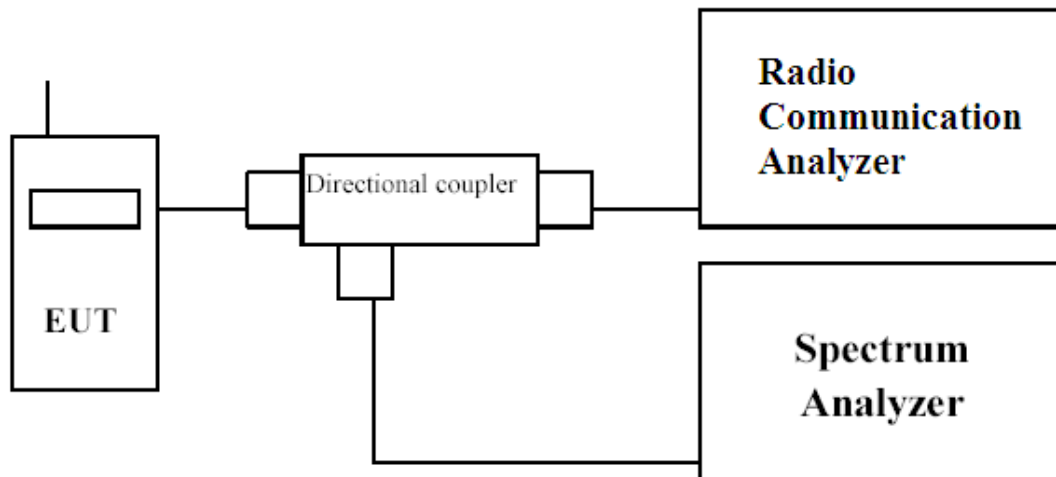

8.3 Limits

The peak-to-average power ratio (PAPR) of the transmitter output power must not exceed 13 dB. The PAPR measurements should be made using either an instrument with complementary cumulative distribution function (CCDF) capabilities to determine that PAPR will not exceed 13 dB for more than 0.1 percent of the time or other Commission approved procedure.

8.4 Test Procedure

- a) Refer to instrument's analyzer instruction manual for details on how to use the power statistics/CCDF function;
- b) Set resolution/measurement bandwidth \geq signal's occupied bandwidth;
- c) Set the number of counts to a value that stabilizes the measured CCDF curve;
- d) Set the measurement interval as follows:
 - 1) for continuous transmissions, set to 1 ms,
 - 2) for burst transmissions, employ an external trigger that is synchronized with the EUT burst timing sequence, or use the internal burst trigger with a trigger level that allows the burst to stabilize and set the measurement interval to a time that is less than or equal to the burst duration.
- e) Record the maximum PAPR level associated with a probability of 0.1%.

8.5 Test Result of Spurious Emission

Product	DCM (Data Communication Module)		
Test Mode	Peak to Average Ratio		
Date of Test	2017/11/17	Test Site	CTR
Test Condition	LTE-Band 2		

Band 2 (1.4M) QPSK CH18900 (1880MHz)

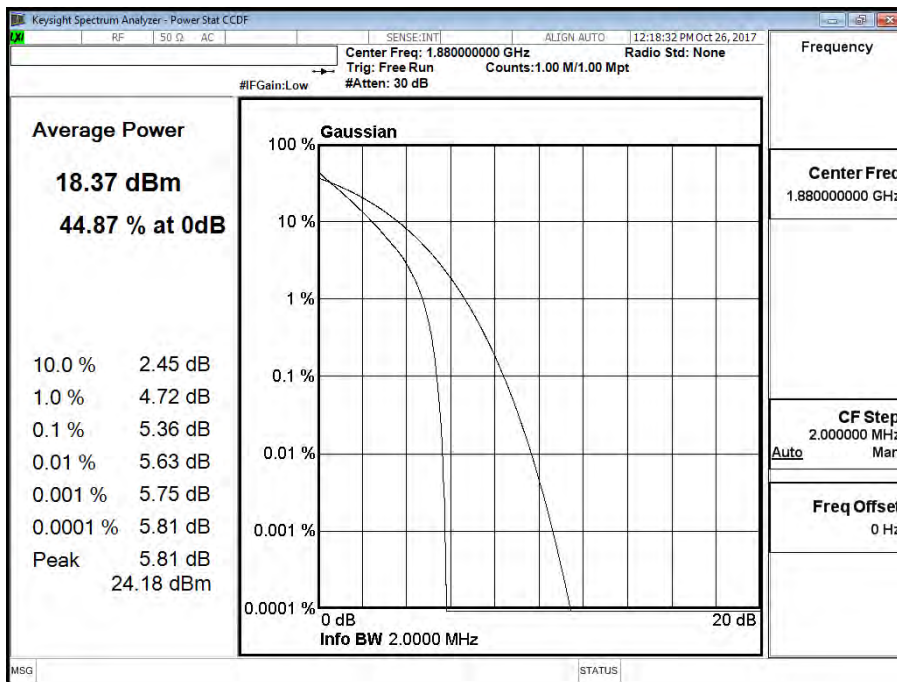

Band 2 (3M) QPSK CH18900 (1880MHz)

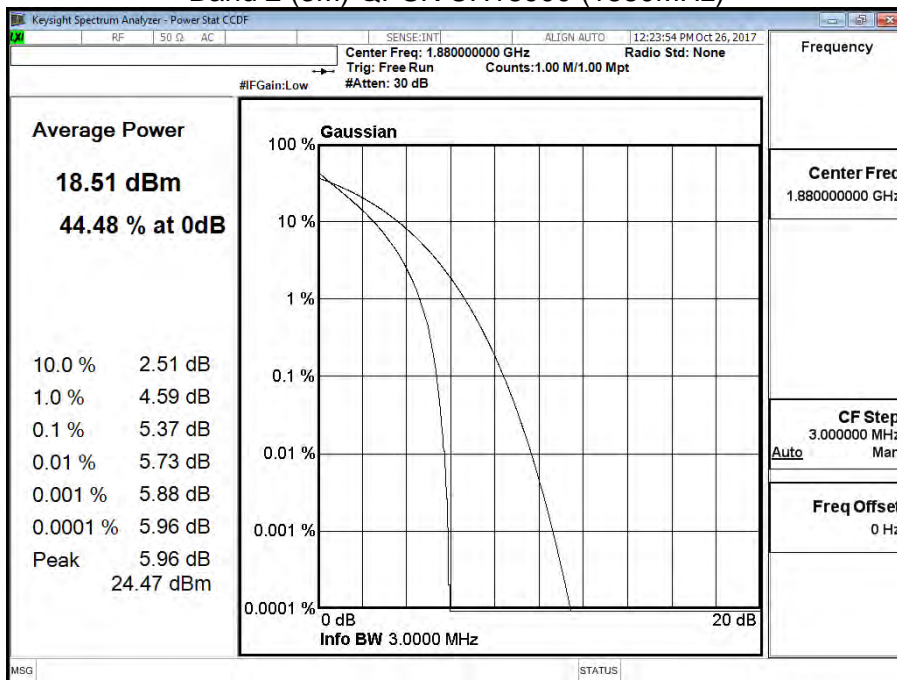

Band 2 (5M) QPSK CH18900 (1880MHz)

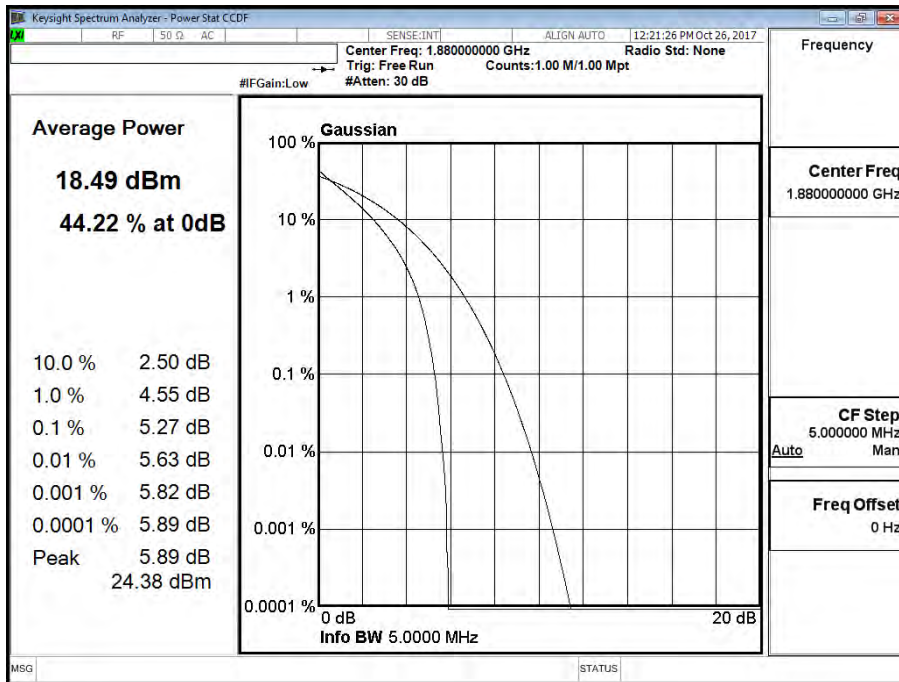

Band 2 (10M) QPSK CH18900 (1880MHz)

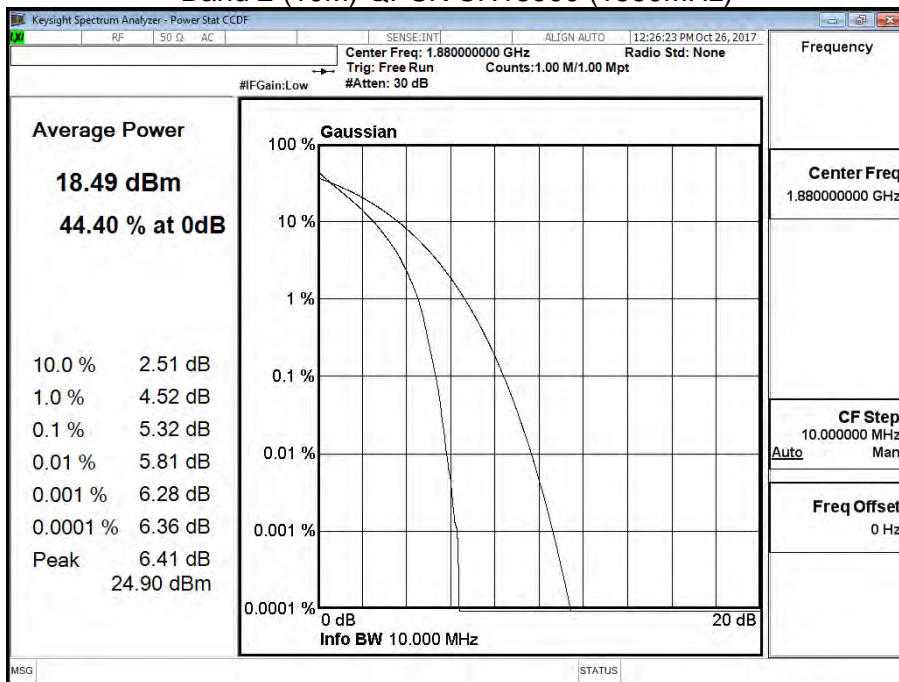

Band 2 (15M) QPSK CH18900 (1880MHz)

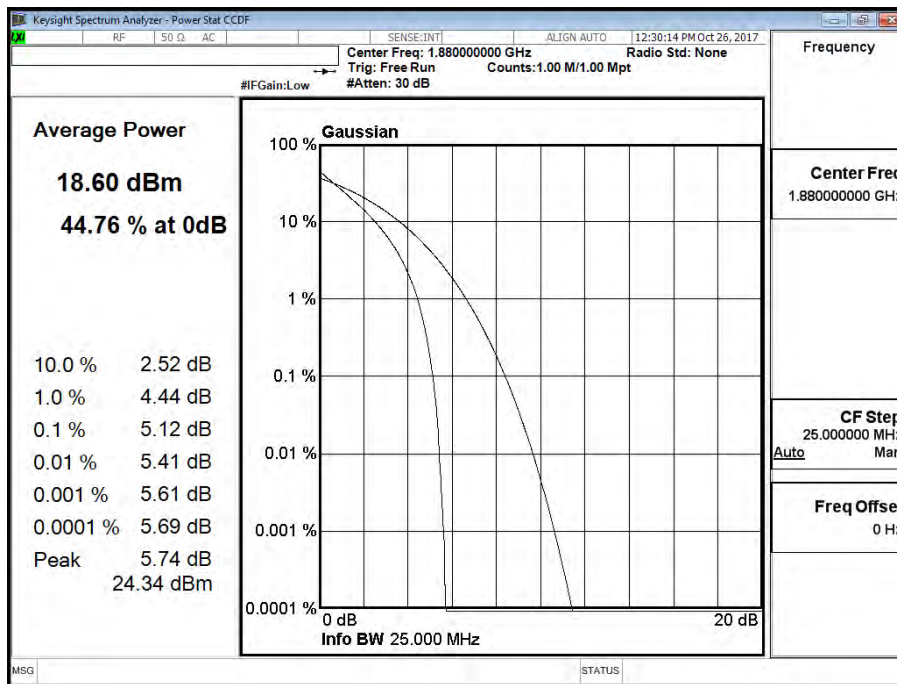

Band 2 (20M) QPSK CH18900 (1880MHz)

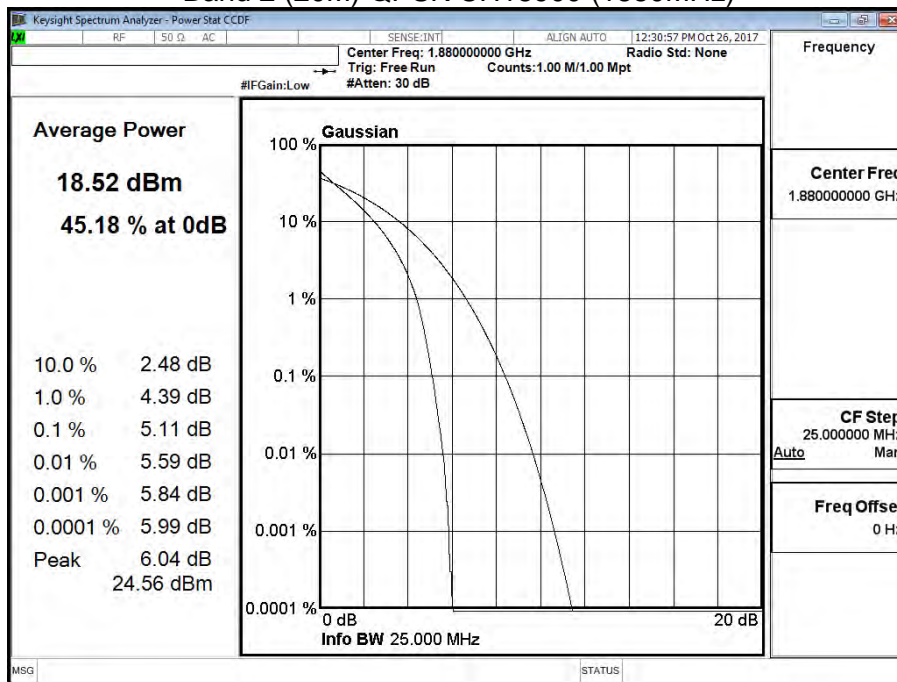

Band 2 (1.4M) 16QAM CH18900 (1880MHz)

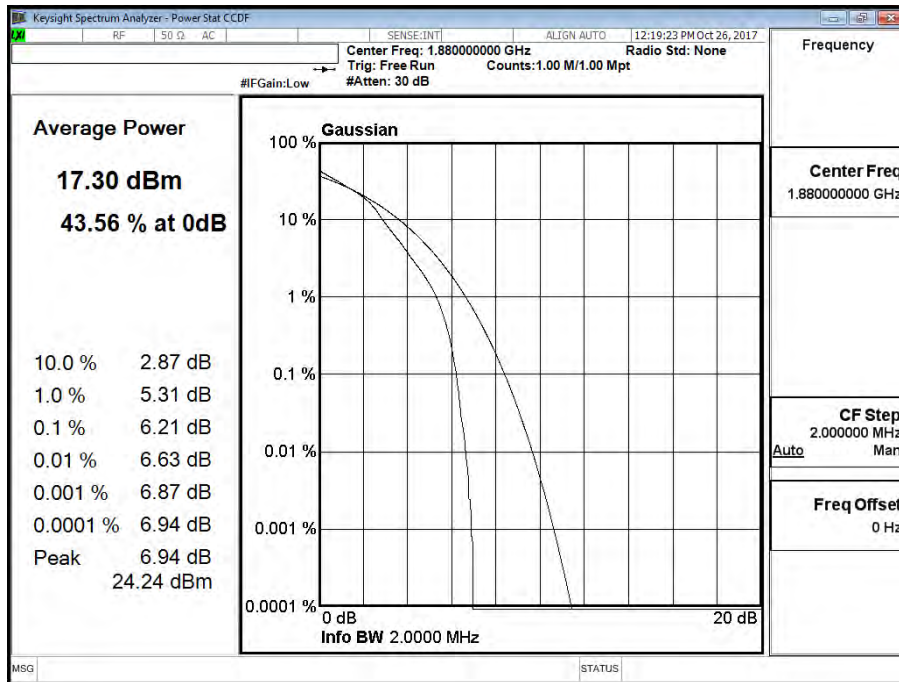

Band 2 (3M) 16QAM CH18900 (1880MHz)

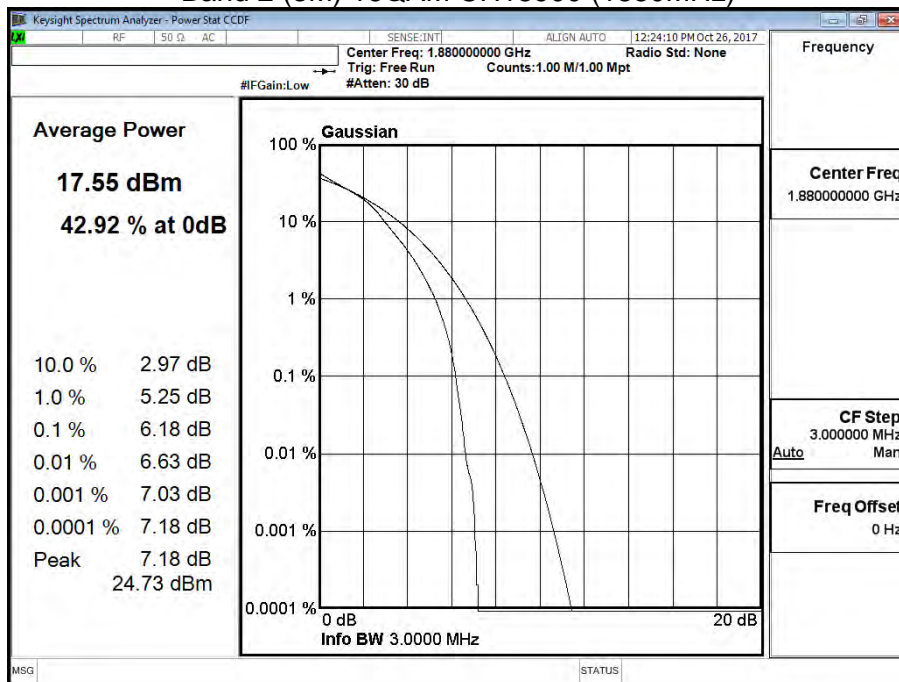

Band 2 (5M) 16QAM CH18900 (1880MHz)

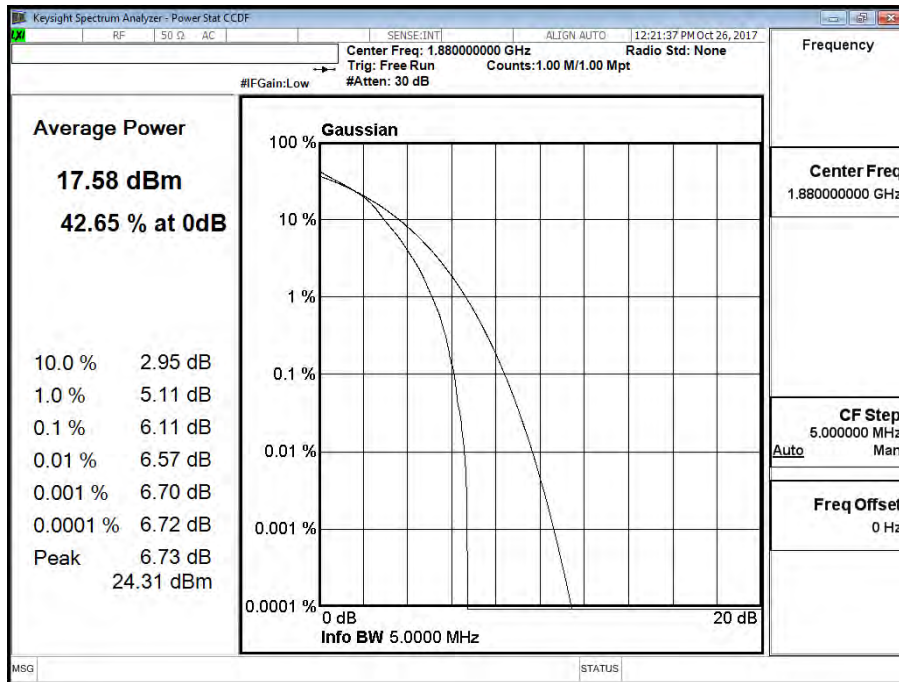

Band 2 (10M) 16QAM CH18900 (1880MHz)

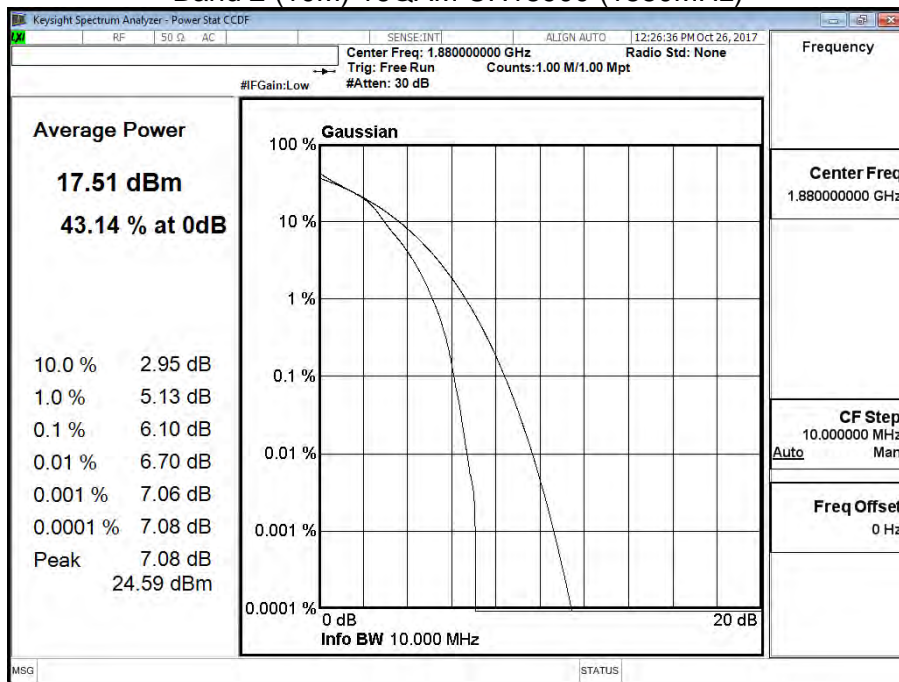

Band 2 (15M) 16QAM CH18900 (1880MHz)

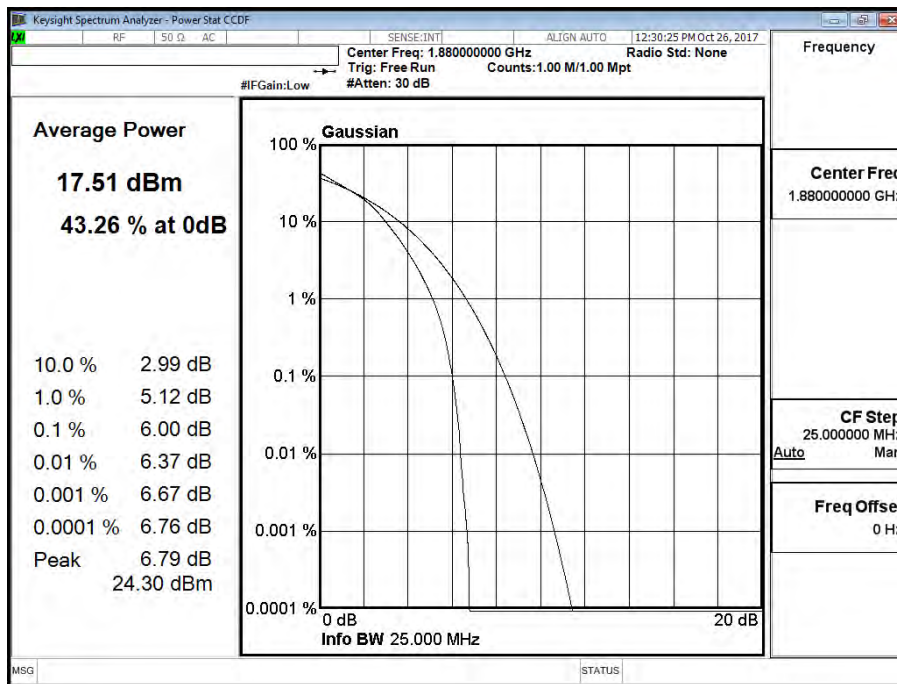

Band 2 (20M) 16QAM CH18900 (1880MHz)

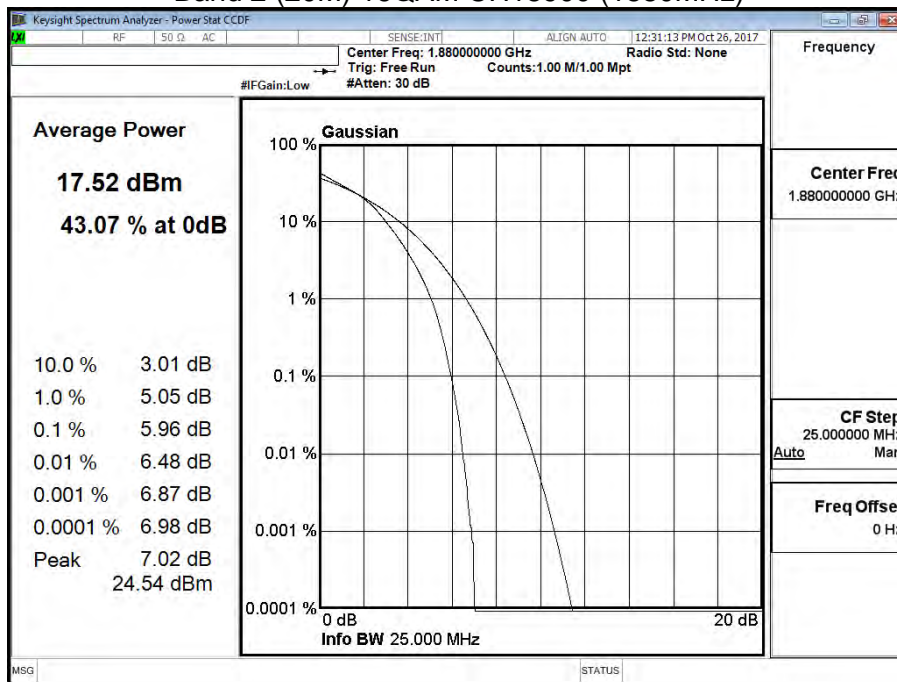

Product	DCM (Data Communication Module)		
Test Mode	Peak to Average Ratio		
Date of Test	2017/11/17	Test Site	CTR
Test Condition	LTE-Band 4		

Band 4 (1.4M) QPSK CH20175 (1732.5MHz)

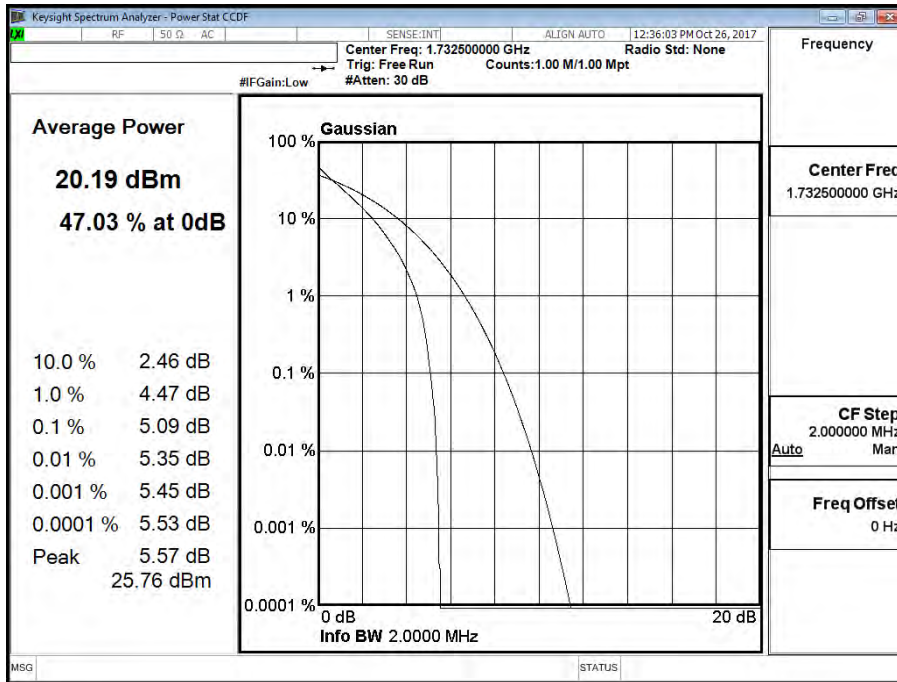

Band 4 (3M) QPSK CH20175 (1732.5MHz)

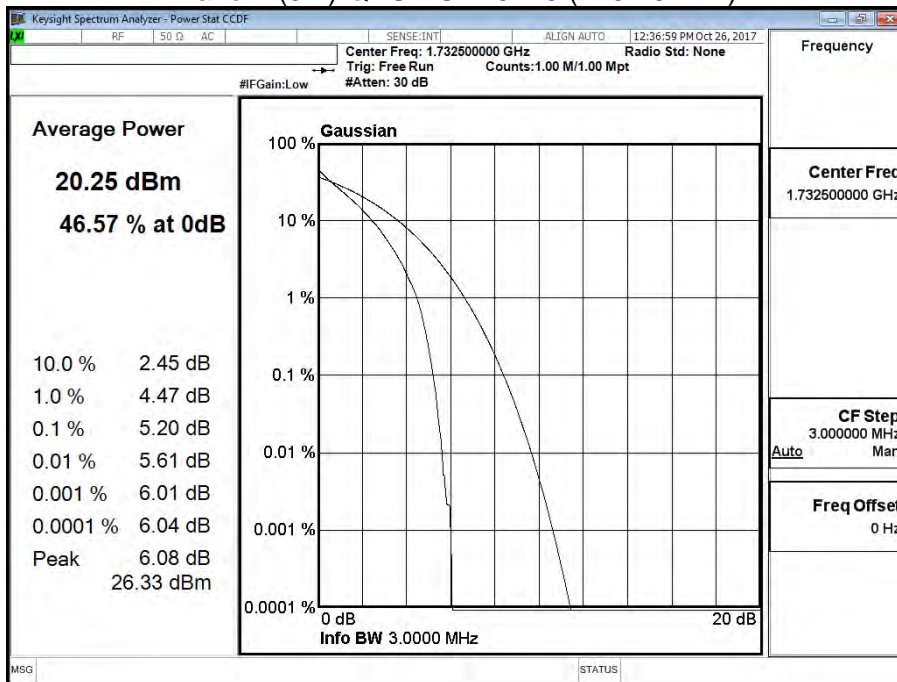

Band 4 (5M) QPSK CH20175 (1732.5MHz)

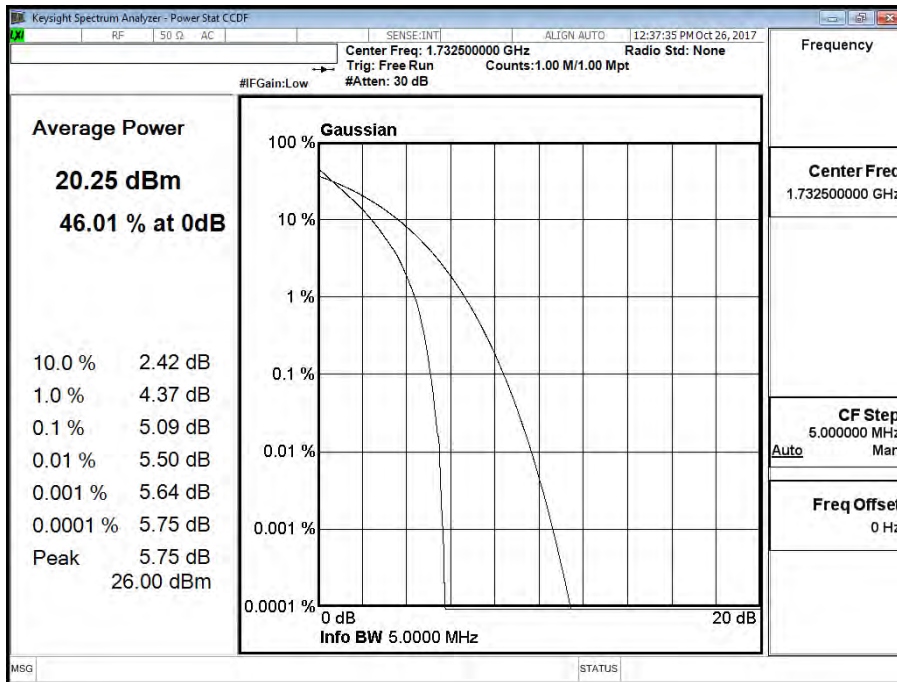

Band 4 (10M) QPSK CH20175 (1732.5MHz)

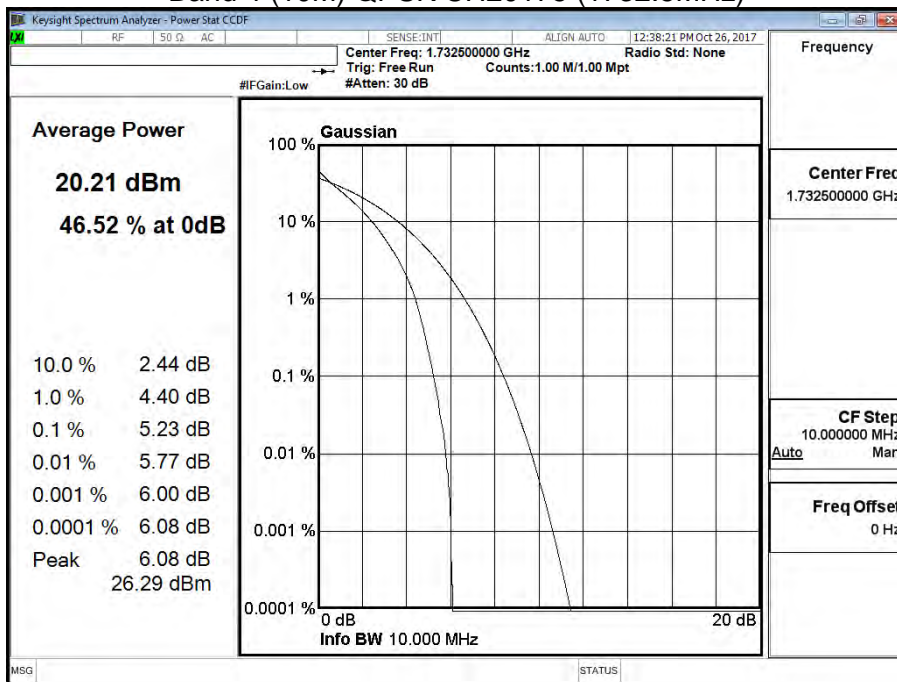

Band 4 (15M) QPSK CH20175 (1732.5MHz)

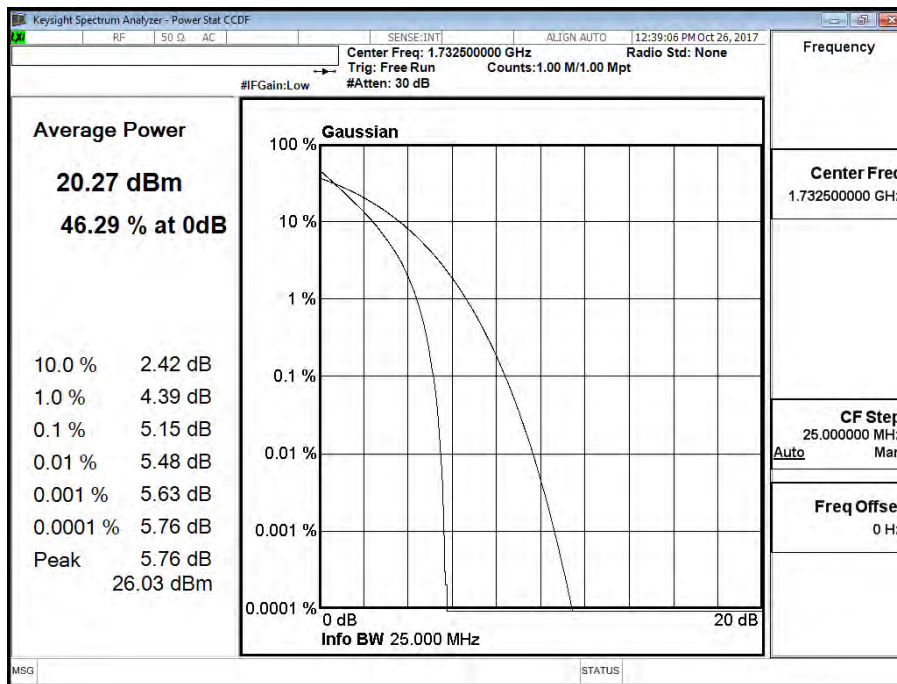

Band 4 (20M) QPSK CH20175 (1732.5MHz)

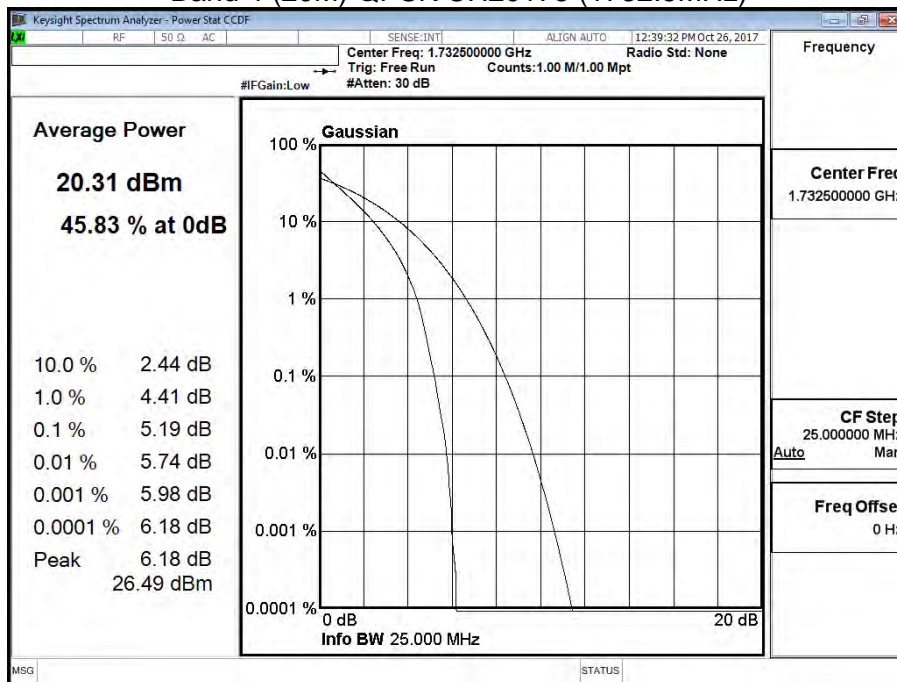

Band 4 (1.4M) 16QAM CH20175 (1732.5MHz)

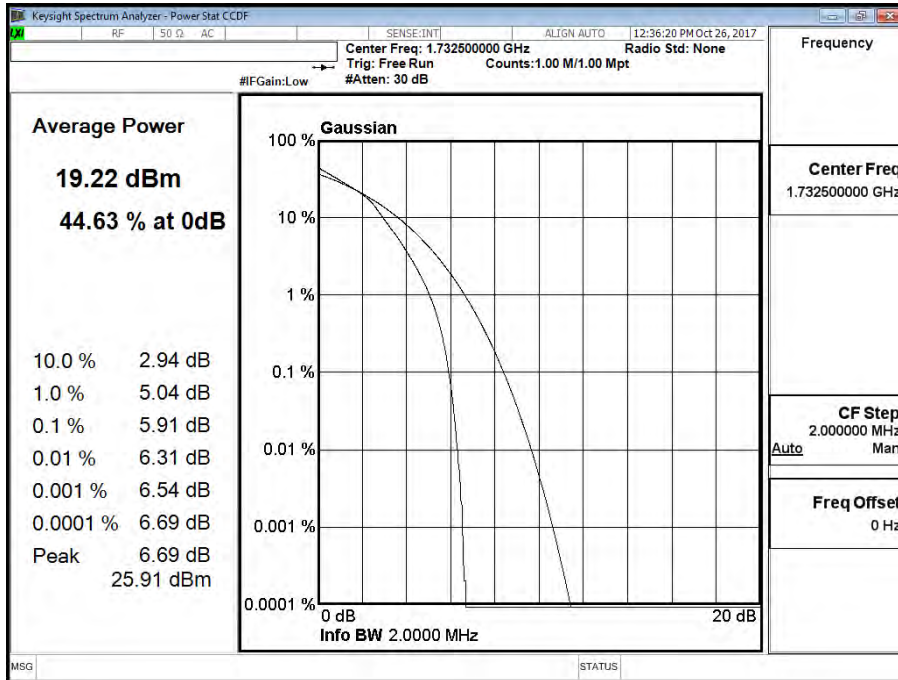

Band 4 (3M) 16QAM CH20175 (1732.5MHz)

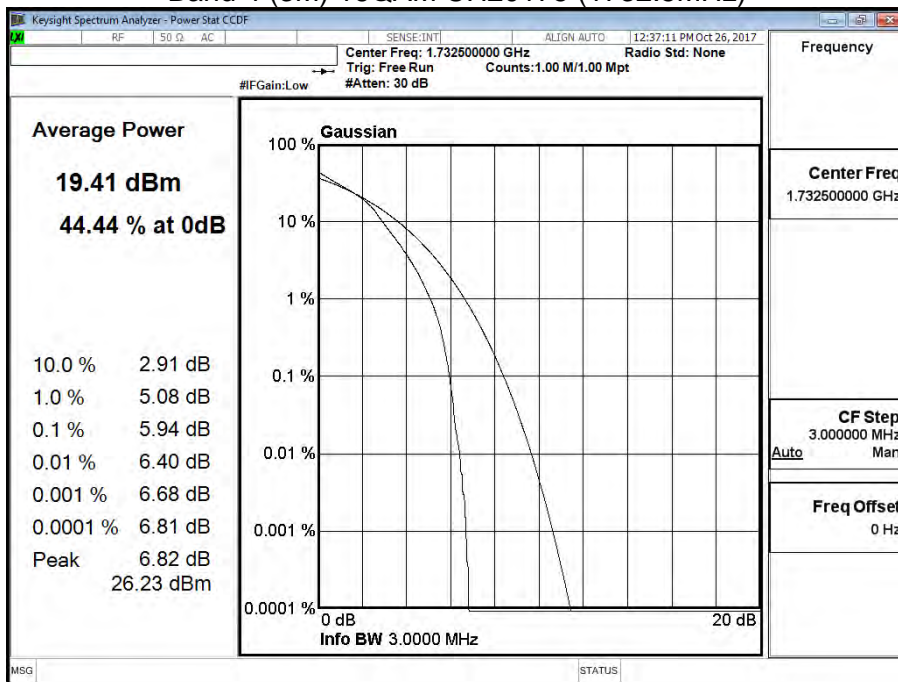

Band 4 (5M) 16QAM CH20175 (1732.5MHz)

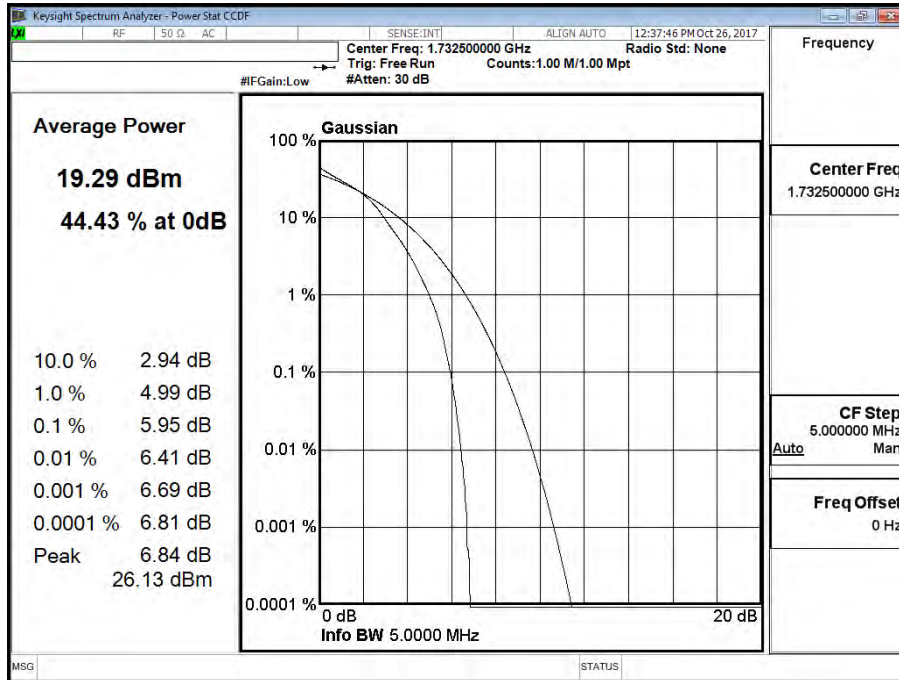

Band 4 (10M) 16QAM CH20175 (1732.5MHz)

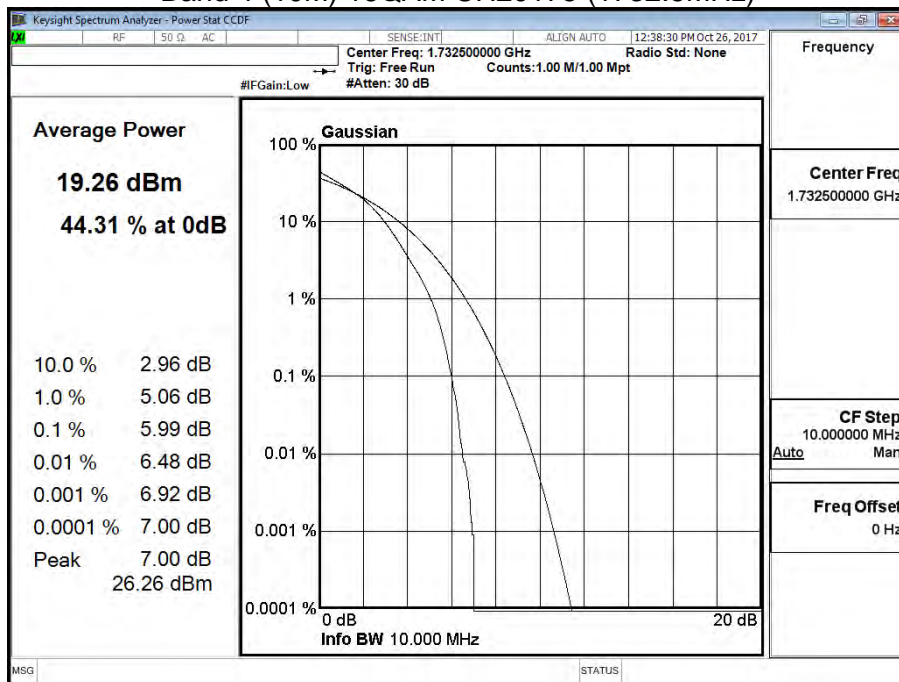

Band 4 (15M) 16QAM CH20175 (1732.5MHz)

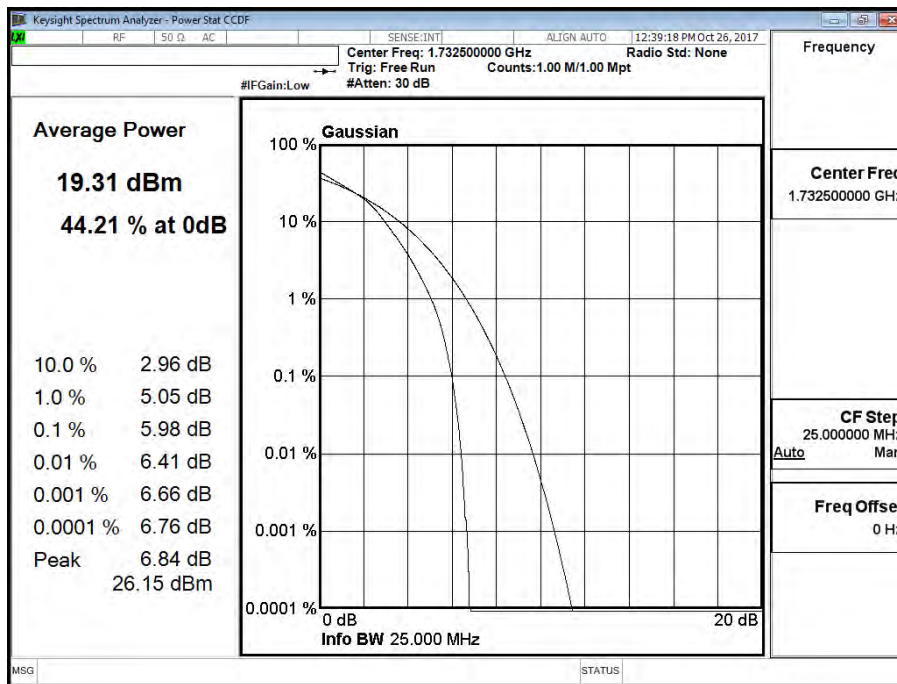

Band 4 (20M) 16QAM CH20175 (1732.5MHz)

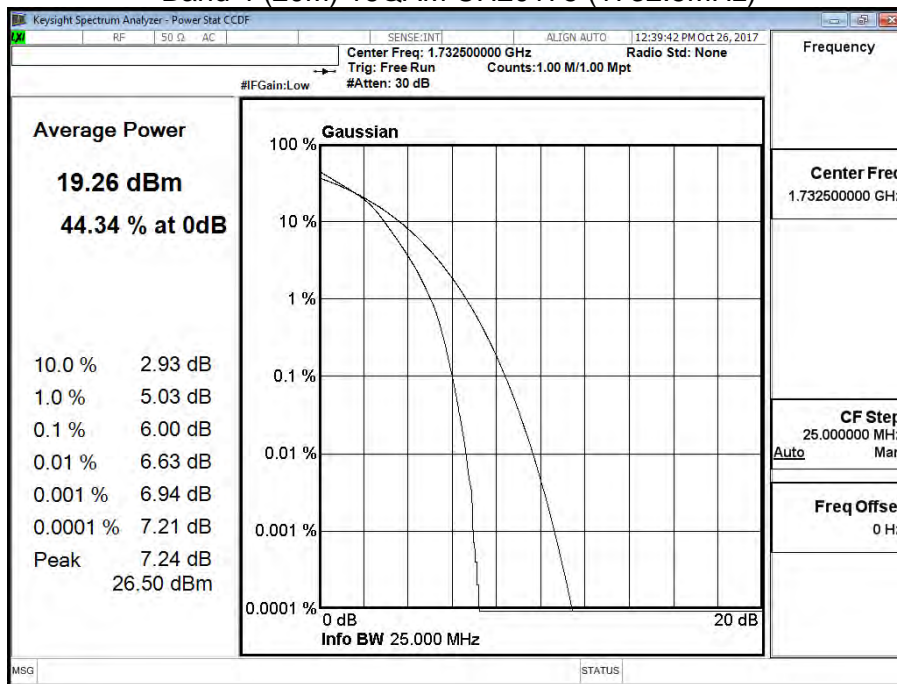

Product	DCM (Data Communication Module)		
Test Mode	Peak to Average Ratio		
Date of Test	2017/11/17	Test Site	CTR
Test Condition	LTE-Band 5		

Band 5 (1.4M) QPSK CH20525 (836.5MHz)

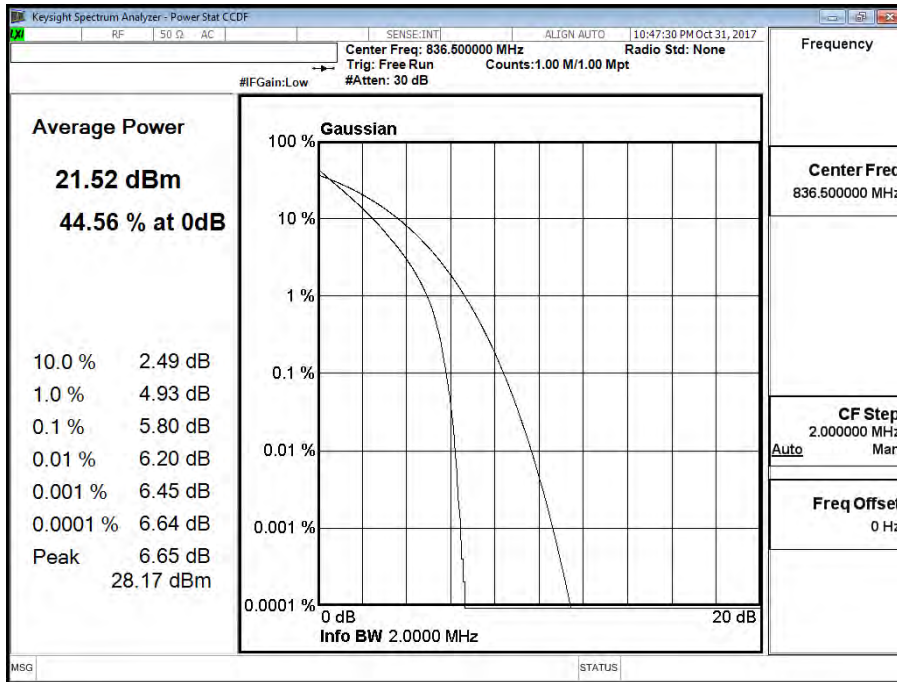

Band 5 (3M) QPSK CH20525 (836.5MHz)

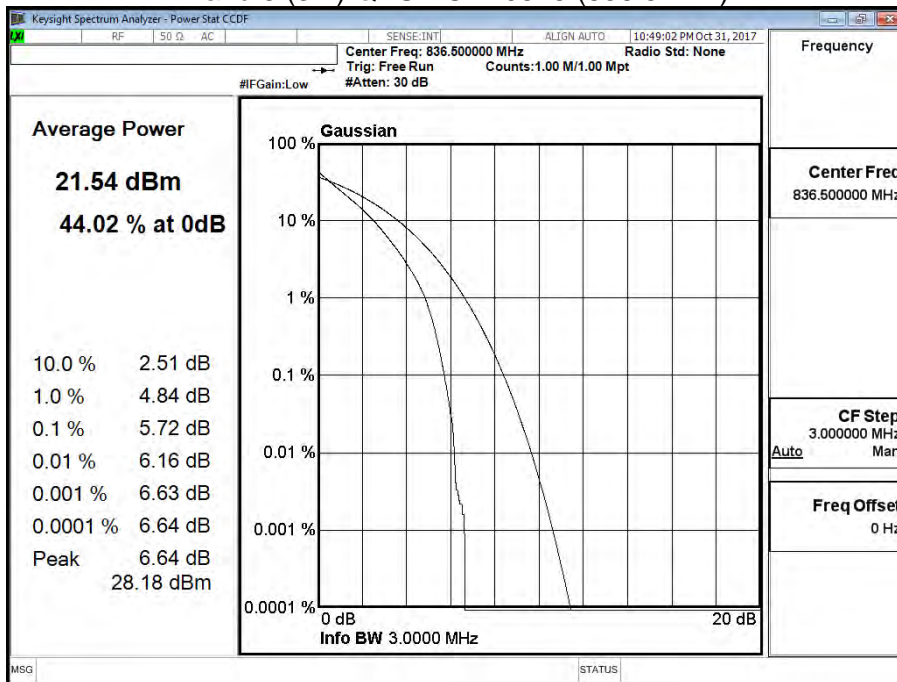

Band 5 (5M) QPSK CH20525 (836.5MHz)

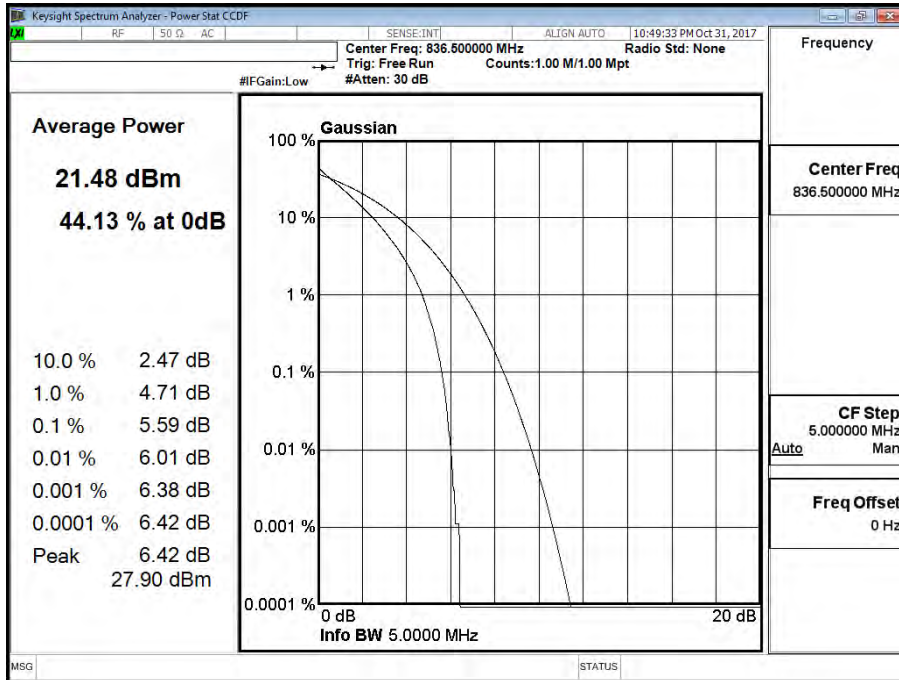

Band 5 (10M) QPSK CH20525 (836.5MHz)

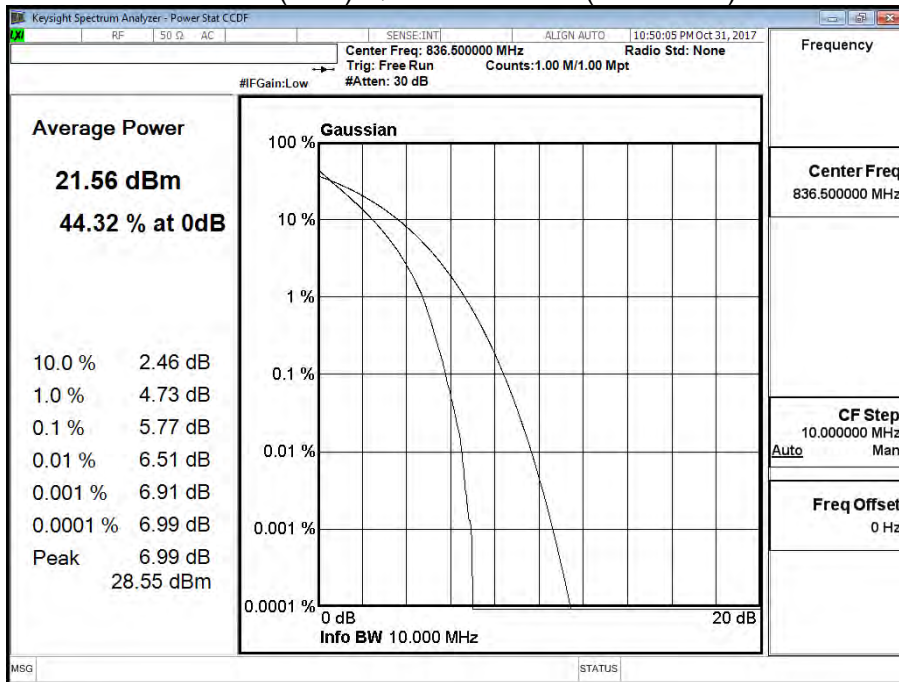

Band 5 (1.4M) 16QAM CH20525 (836.5MHz)

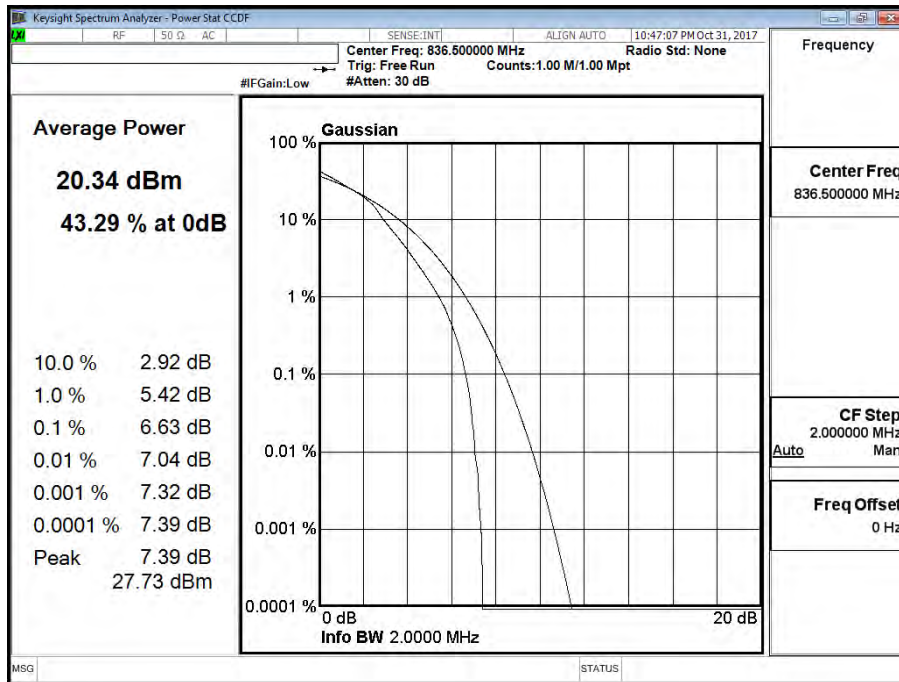

Band 5 (3M) 16QAM CH20525 (836.5MHz)

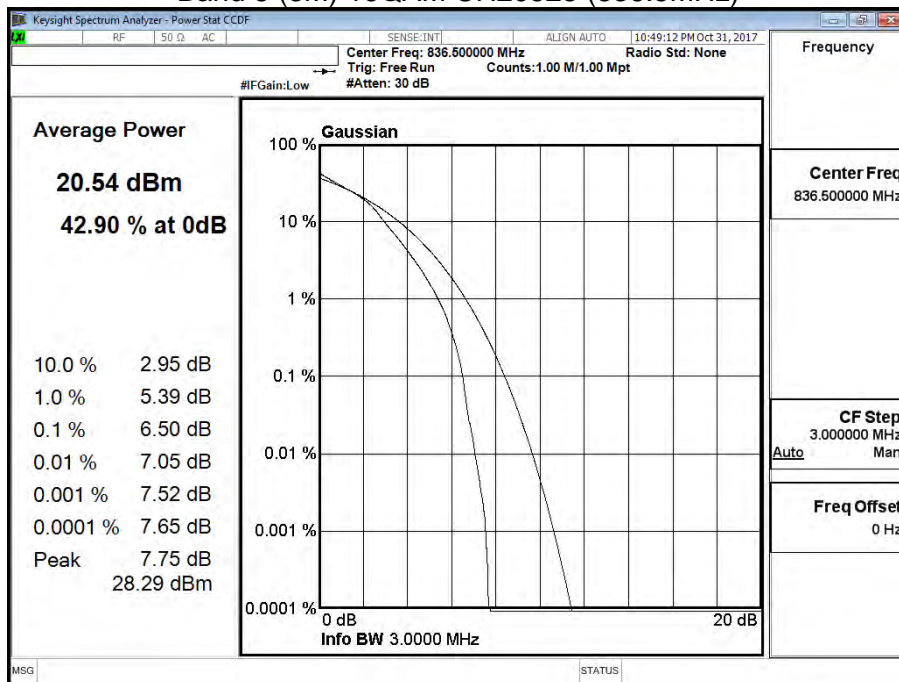

Band 5 (5M) 16QAM CH20525 (836.5MHz)

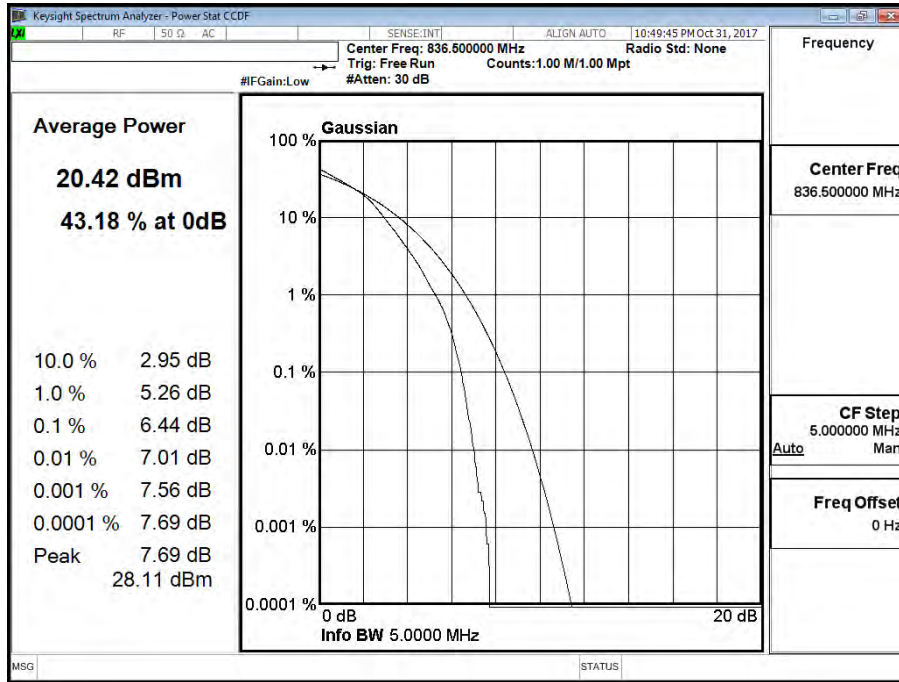

Band 5 (10M) 16QAM CH20525 (836.5MHz)

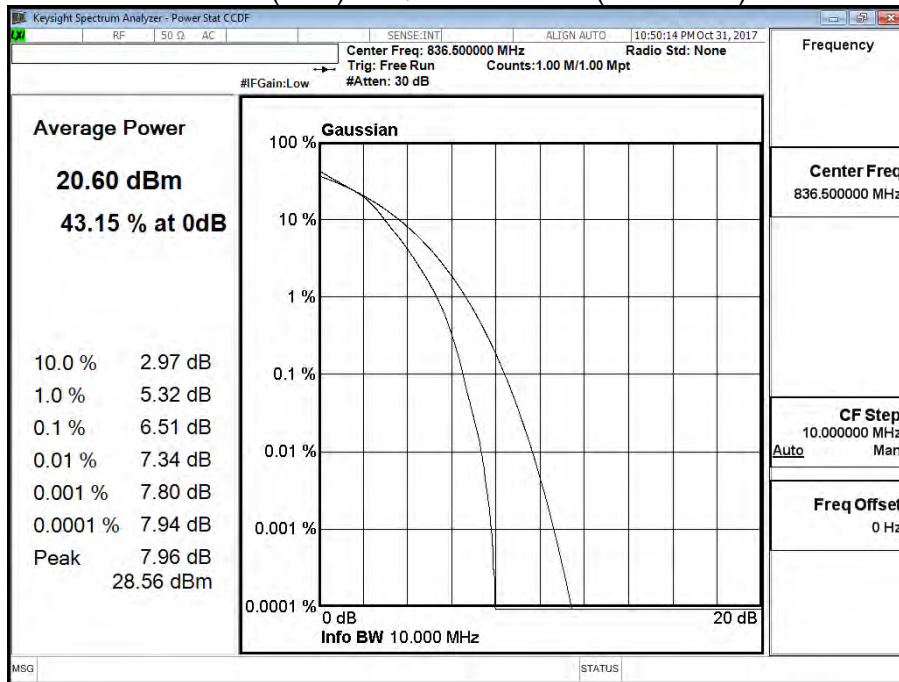

Product	DCM (Data Communication Module)		
Test Mode	Peak to Average Ratio		
Date of Test	2017/11/17	Test Site	CTR
Test Condition	LTE-Band 17		

Band 17 (5M) QPSK CH23790 (710MHz)

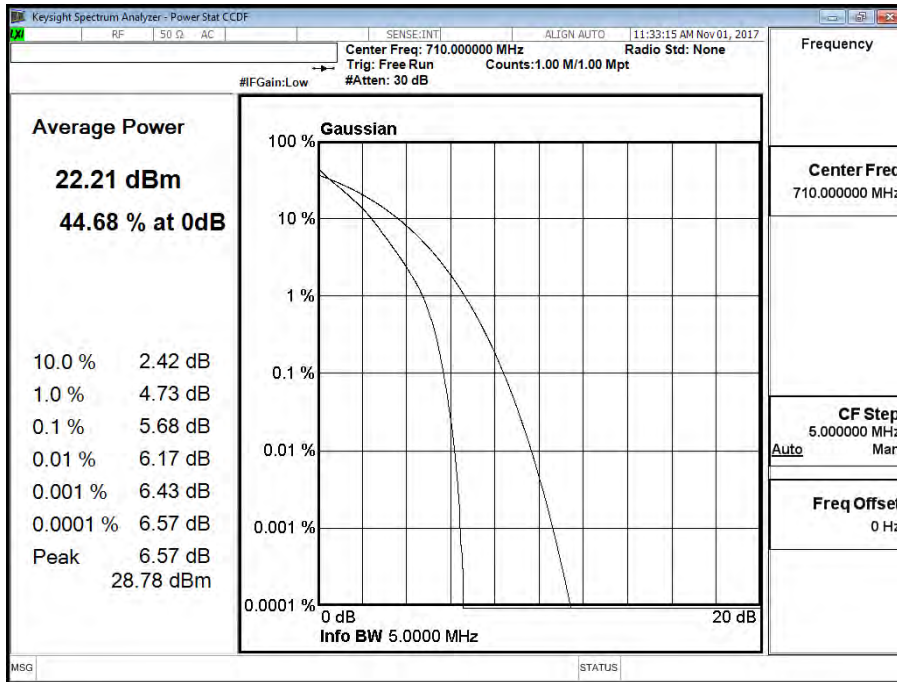

Band 17 (10M) QPSK CH23790 (710MHz)

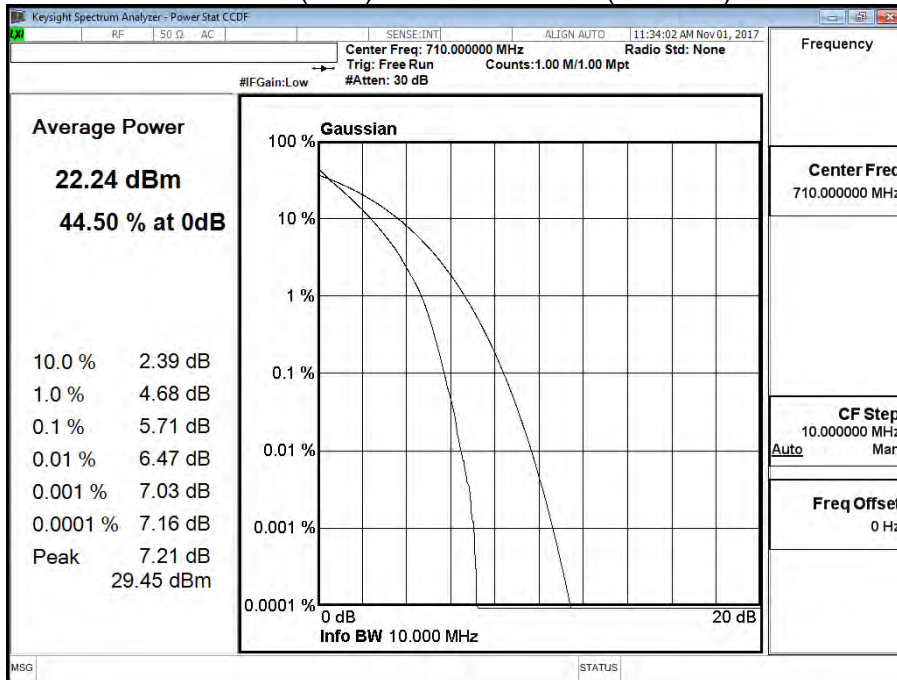

Band 17 (5M) 16QAM CH23790 (710MHz)

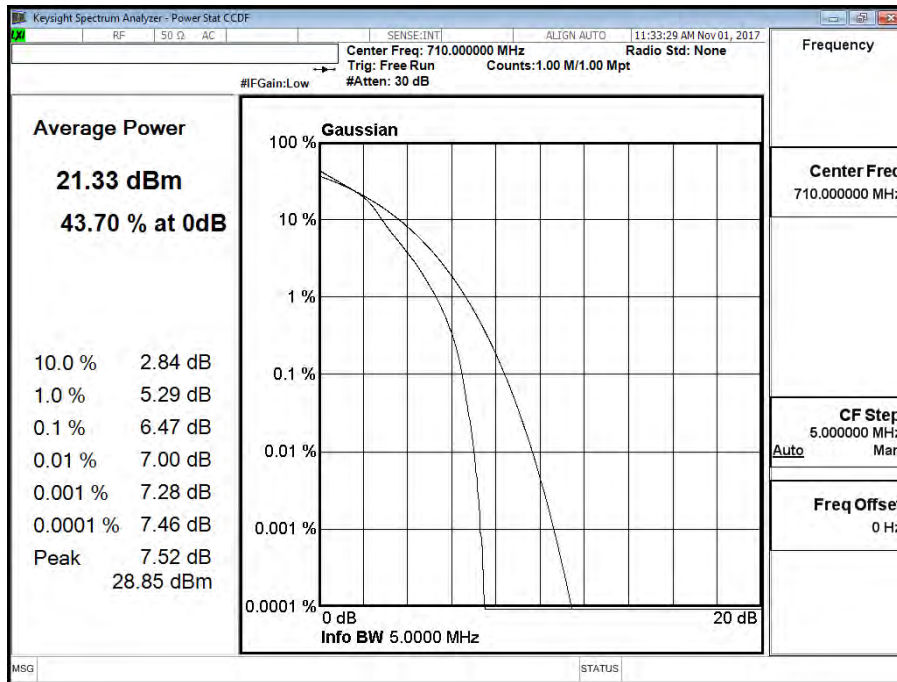

Band 17 (10M) 16QAM CH23790 (710MHz)

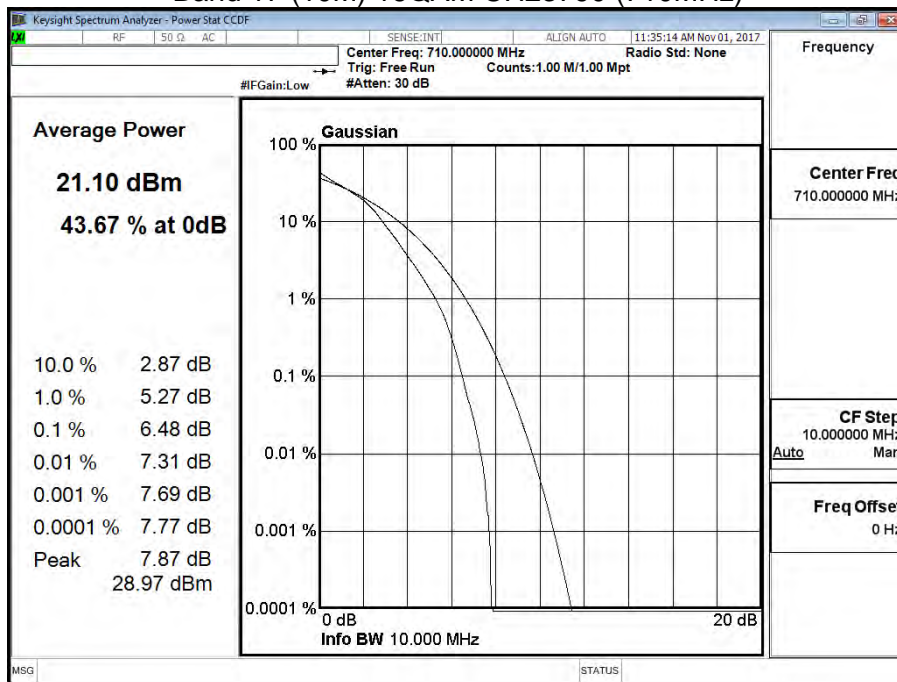

Product	DCM (Data Communication Module)		
Test Mode	Peak to Average Ratio		
Date of Test	2017/11/17	Test Site	CTR
Test Condition	LTE-Band 26		

Band 26 (1.4M) QPSK CH26915 (836.5MHz)

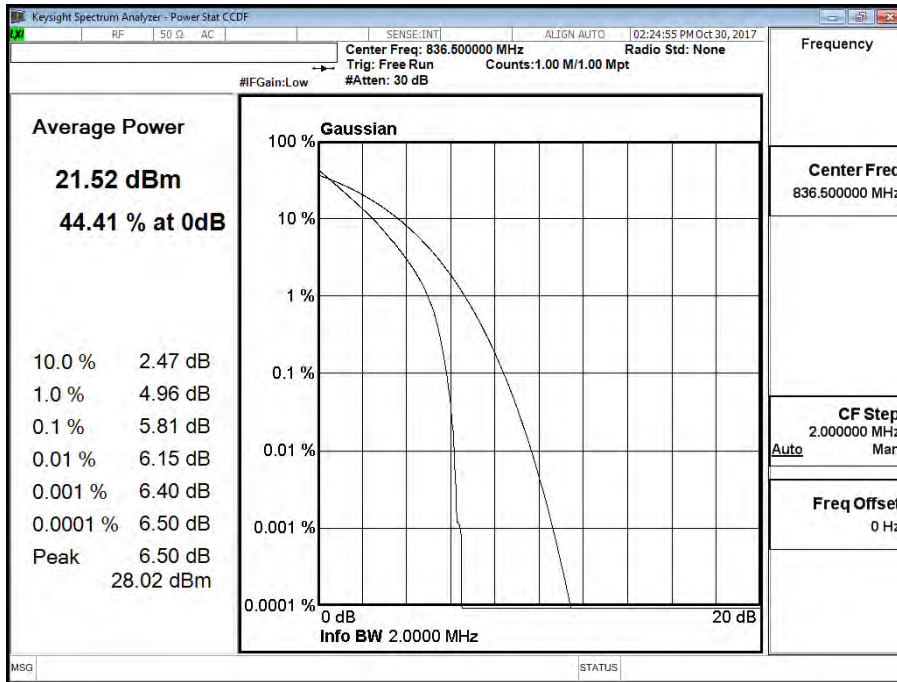

Band 26 (3M) QPSK CH26915 (836.5MHz)

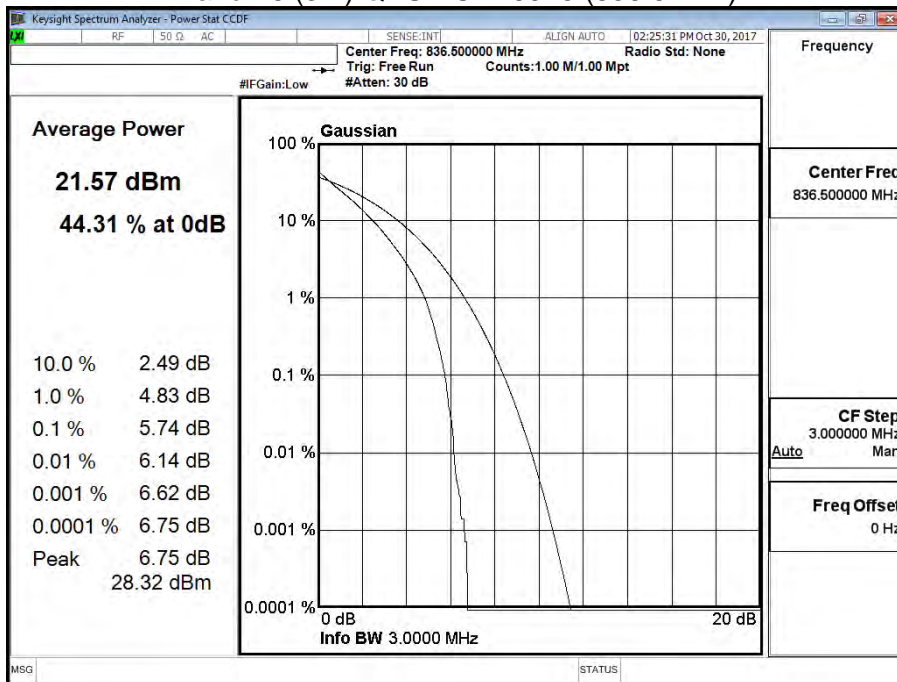

Band 26 (5M) QPSK CH26915 (836.5MHz)

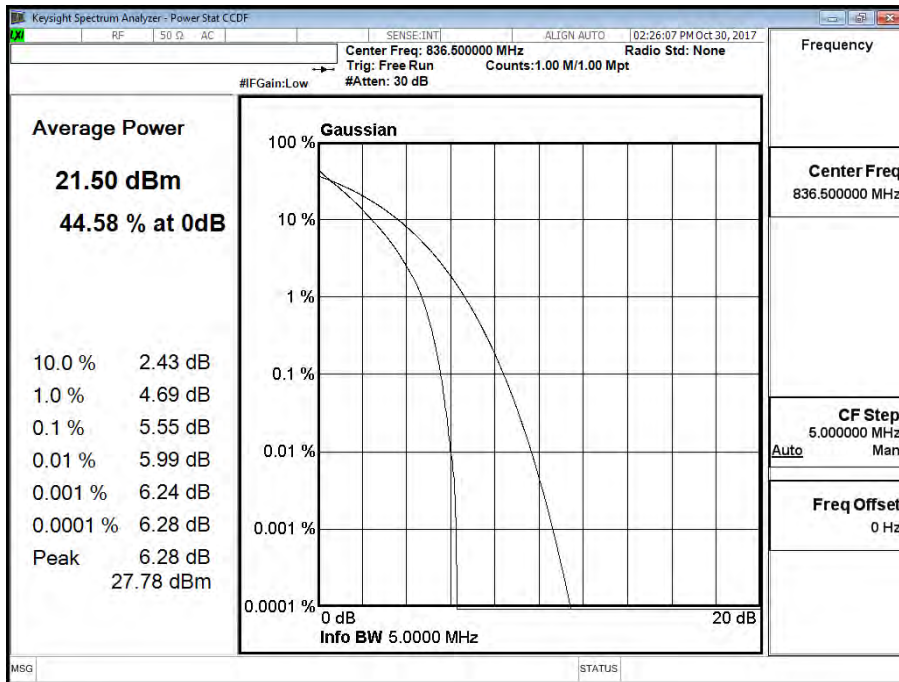

Band 26 (10M) QPSK CH26915 (836.5MHz)

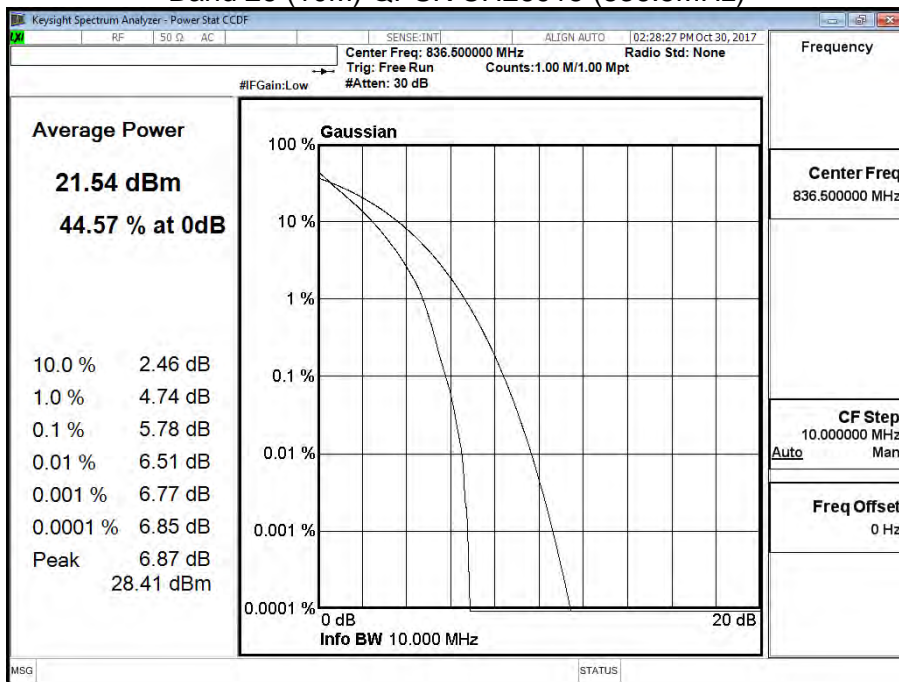

Band 26 (15M) QPSK CH26915 (836.5MHz)

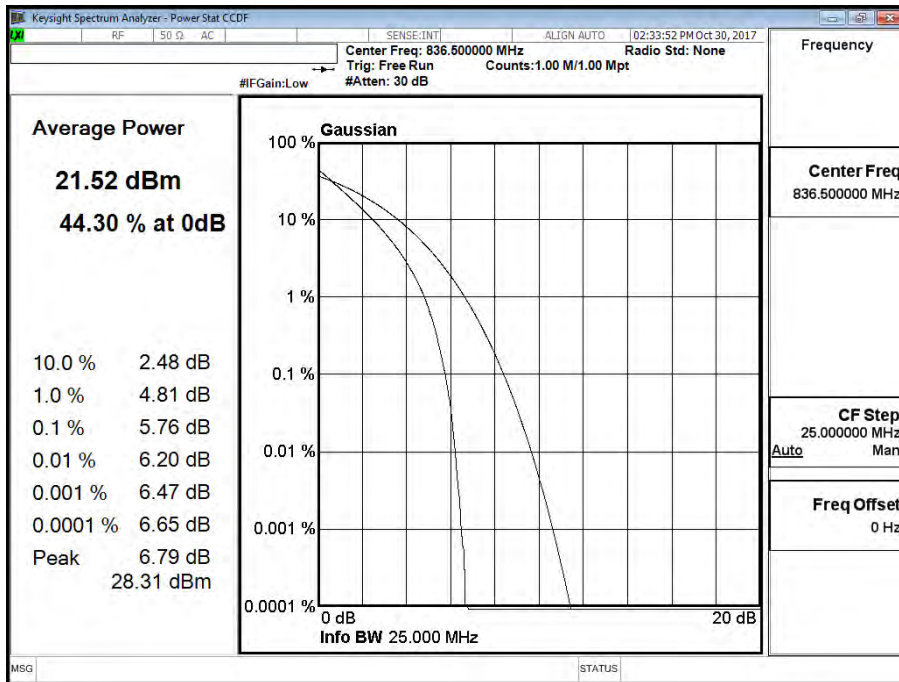

Band 26 (1.4M) 16QAM CH26915 (836.5MHz)

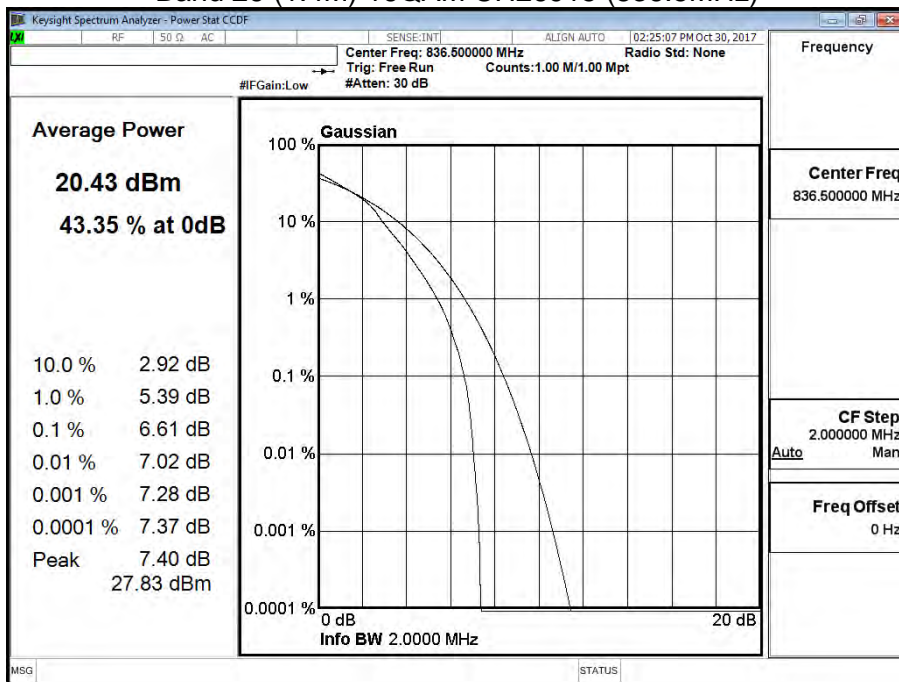

Band 26 (3M) 16QAM CH26915 (836.5MHz)

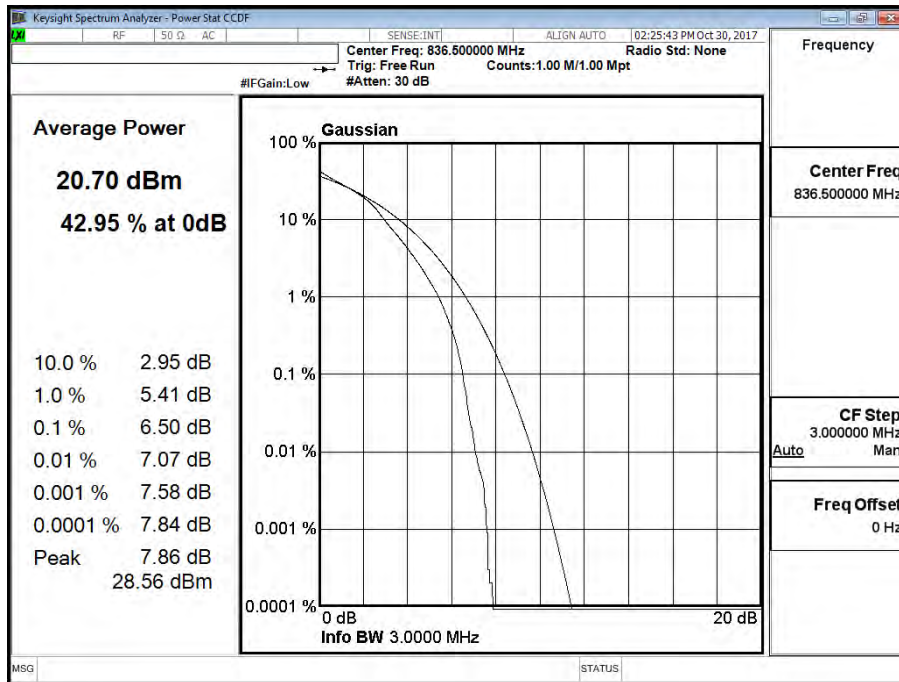

Band 26 (5M) 16QAM CH26915 (836.5MHz)

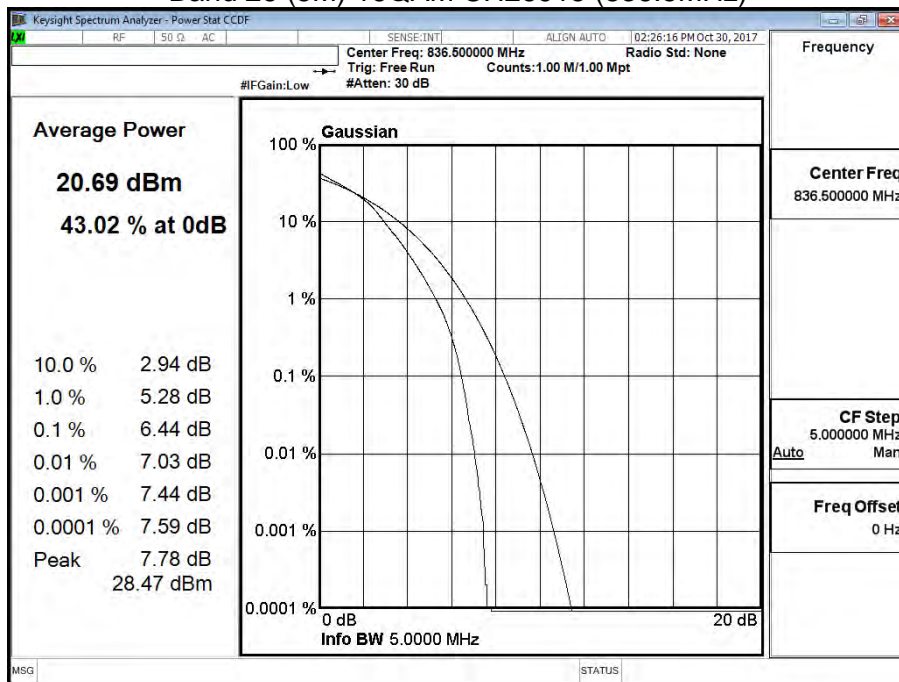

Band 26 (10M) 16QAM CH26915 (836.5MHz)

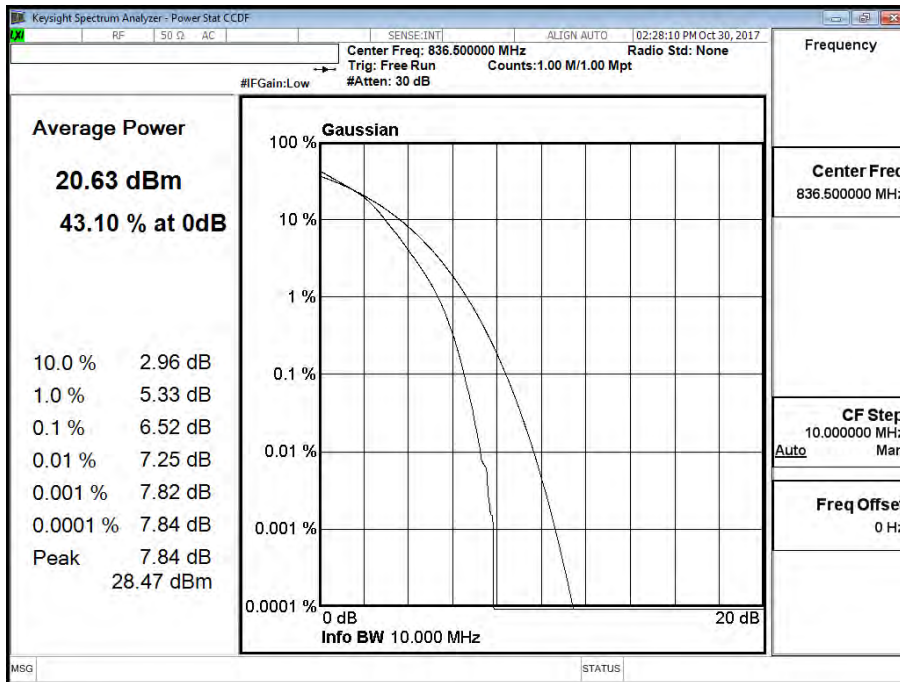

Band 26 (15M) 16QAM CH26915 (836.5MHz)

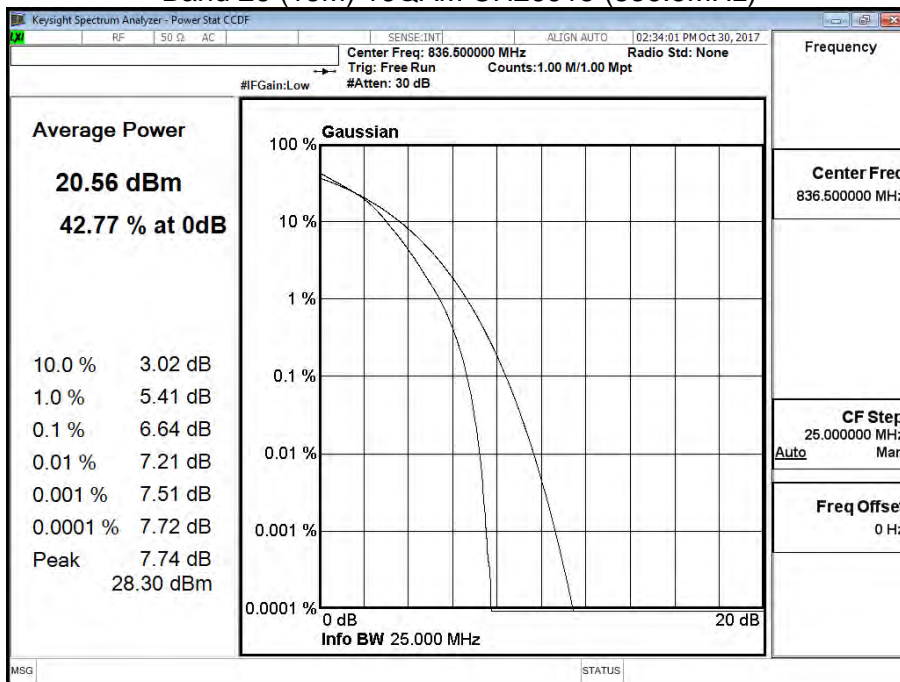

Product	DCM (Data Communication Module)		
Test Mode	Peak to Average Ratio		
Date of Test	2017/11/17	Test Site	CTR
Test Condition	LTE-Band 41		

Band 41 (5M) QPSK CH40620 (2593MHz)

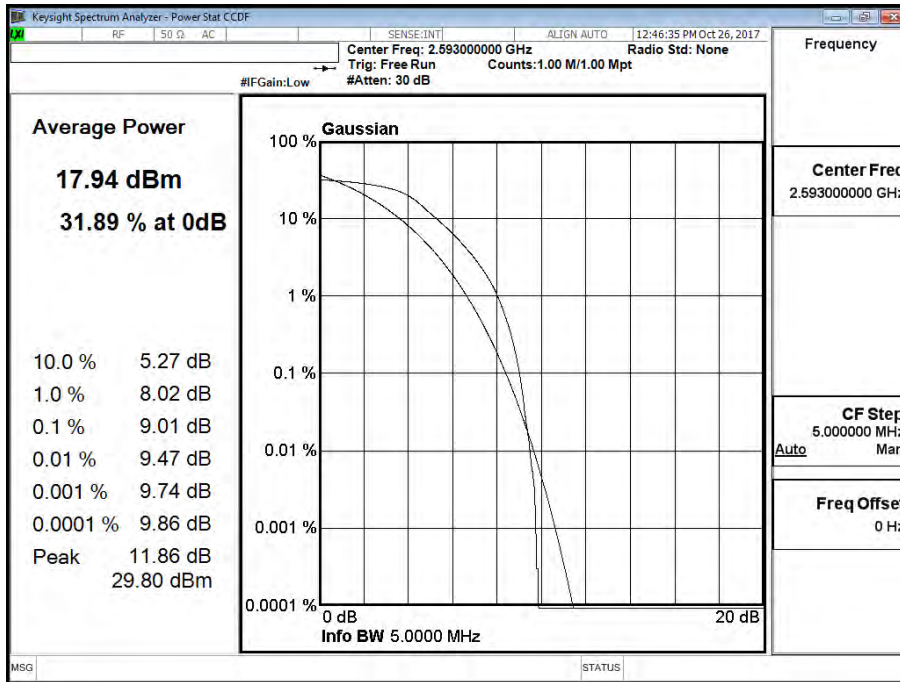

Band 41 (10M) QPSK CH40620 (2593MHz)

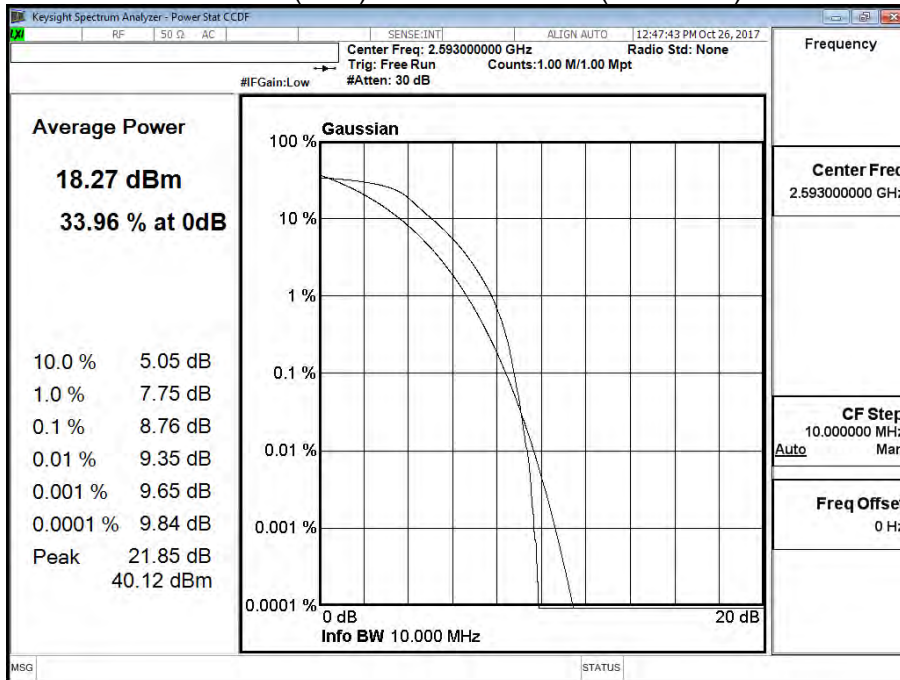

Band 41 (15M) QPSK CH40620 (2593MHz)

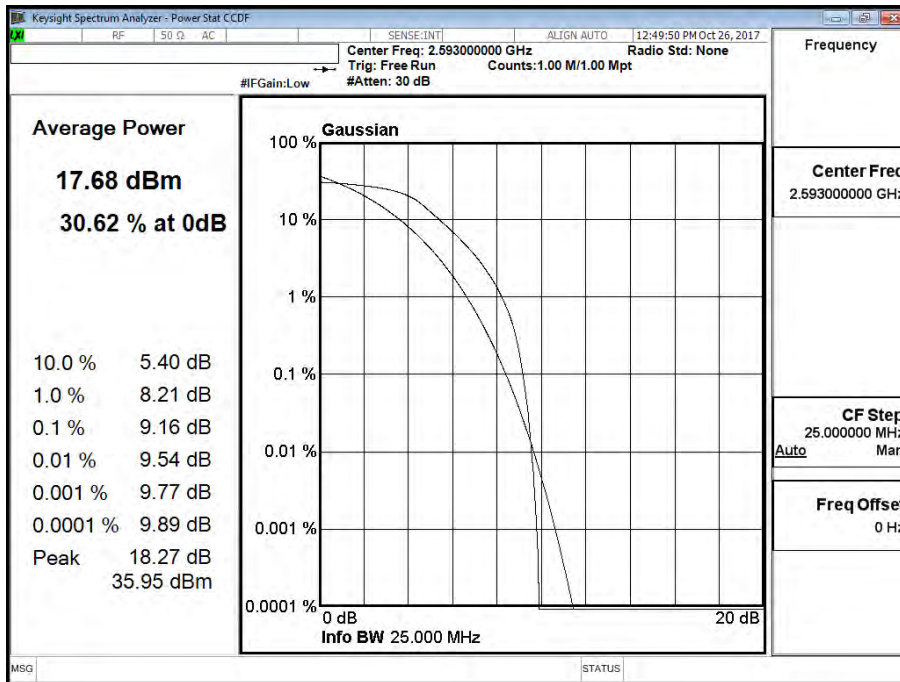

Band 41 (20M) QPSK CH40620 (2593MHz)

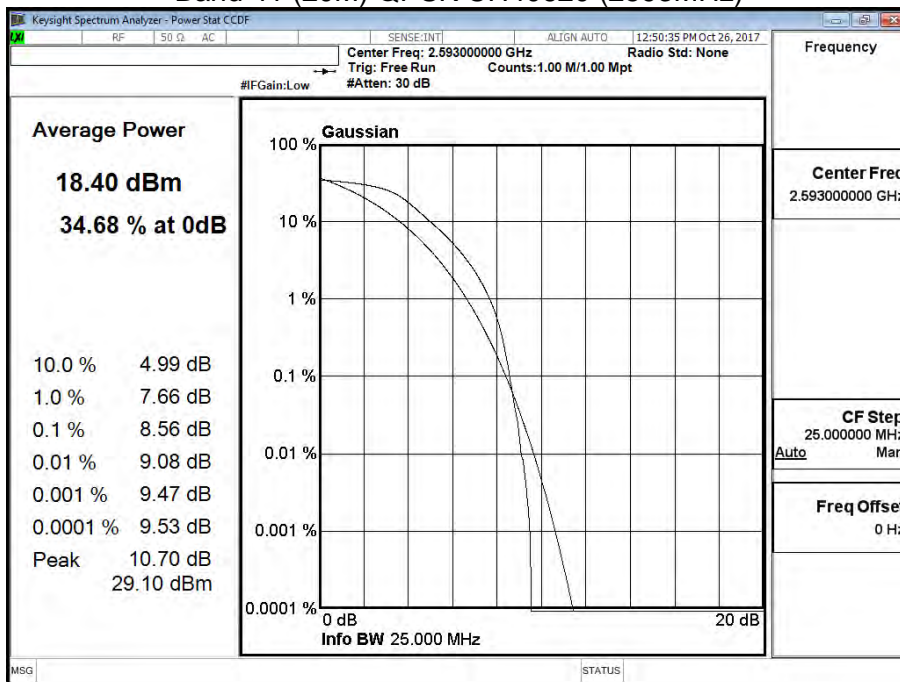

Band 41 (5M) 16QAM CH40620 (2593MHz)

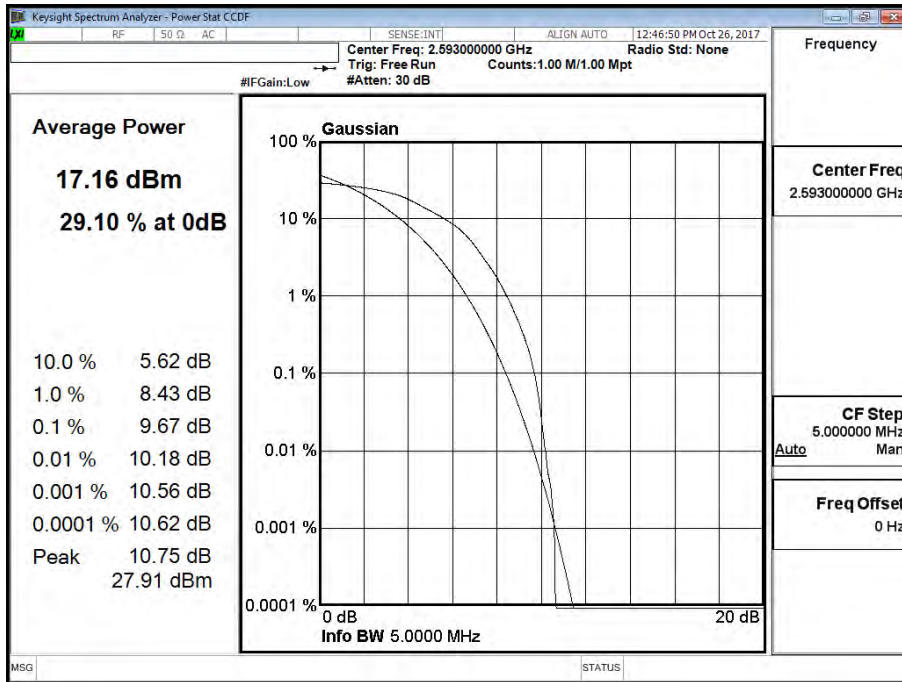

Band 41 (10M) 16QAM CH40620 (2593MHz)

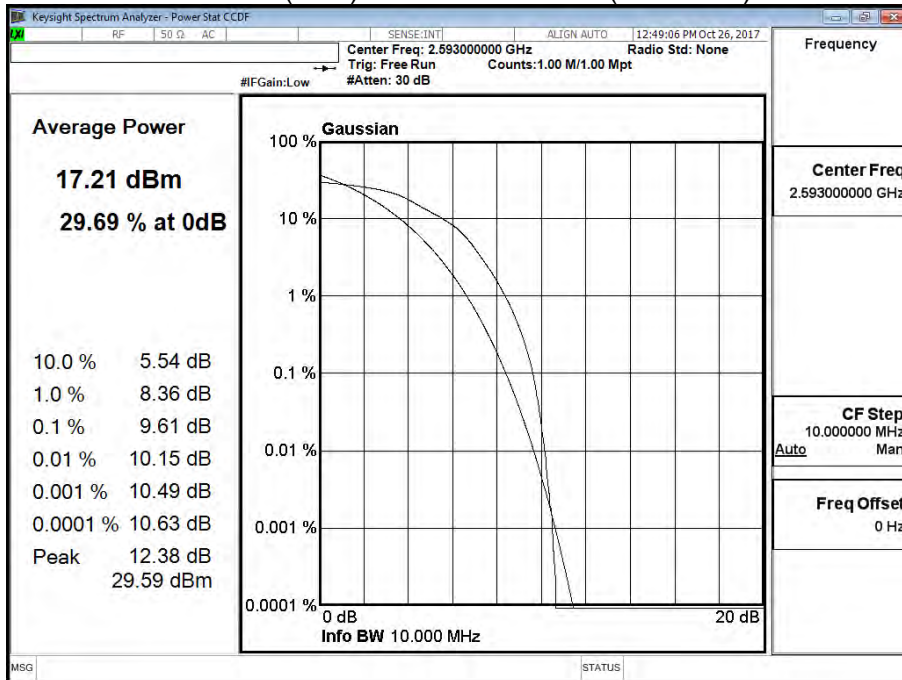

Band 41 (15M) 16QAM CH40620 (2593MHz)

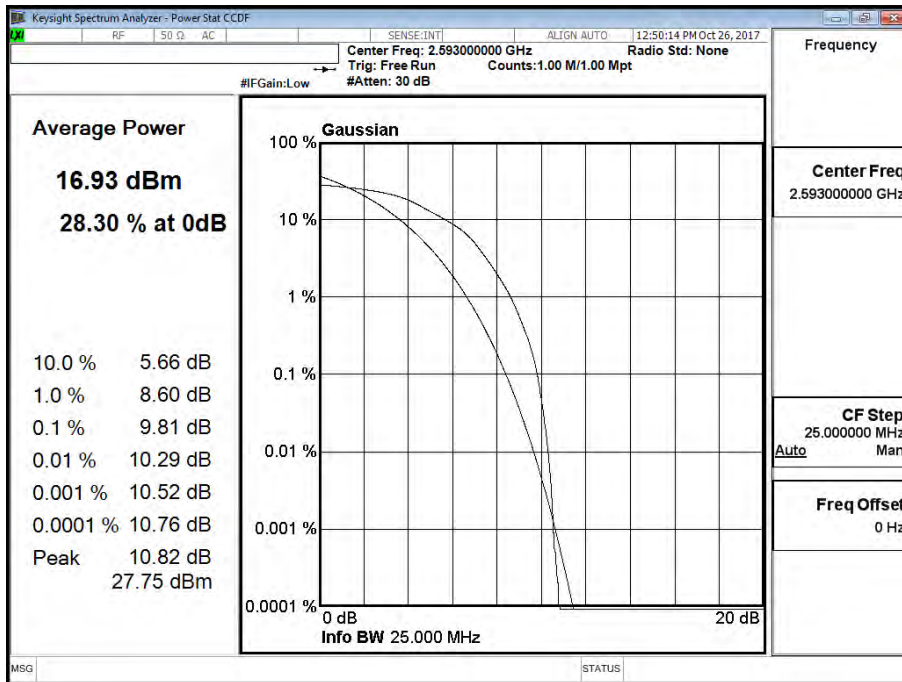

Band 41 (20M) 16QAM CH40620 (2593MHz)

