

MEASUREMENT REPORT

FCC PART 15.247 / ISED RSS-247 Bluetooth-LE

FCC ID: H8N-8822CS
IC: 1353A-8822CS
Applicant: Askey Computer Corp.
Application Type: Certification
Product: WIFI+BT Combo Module
Model No.: 8822CS
Brand Name: ASKEY
FCC Classification: Digital Transmission System (DTS)
FCC Rule Part(s): Part15 Subpart C (Section 15.247)
ISED Rule(s): RSS-247 Issue 2, RSS-GEN Issue 5
Test Procedure(s): ANSI C63.10-2013, KDB 558074 D01v05r02
Test Date: January 21 ~ March 04, 2021

Reviewed By:



Kevin Guo

Approved By:

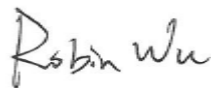

Robin Wu



The test results relate only to the samples tested.

This equipment has been shown to be capable of compliance with the applicable technical standards as indicated in the measurement report and was tested in accordance with the measurement procedures specified in ANSI C63.10-2013. Test results reported herein relate only to the item(s) tested.

The test report shall not be reproduced except in full without the written approval of MRT Technology (Suzhou) Co., Ltd.

Revision History

Report No.	Version	Description	Issue Date	Note
2101RSU052-U2	Rev. 01	Initial Report	03-06-2021	Valid

CONTENTS

Description	Page
1. General Information	5
1.1. Applicant	5
1.2. Manufacturer	5
1.3. Testing Facility.....	5
2. PRODUCT INFORMATION	6
2.1. Equipment Description	6
2.2. Product Specification Subjective to this Report	6
2.3. Working Frequencies for this report.....	6
2.4. Description of Available Antennas	7
2.5. Description of Antenna	7
2.6. Test Mode	8
2.7. Configuration of Test System	8
2.8. Test System Details	8
2.9. Test Software	8
2.10. Test Environment Condition.....	9
2.11. Duty Cycle.....	9
2.12. EMI Suppression Device(s)/Modifications.....	9
2.13. Labeling Requirements.....	10
3. ANTENNA REQUIREMENTS.....	11
4. TEST EQUIPMENT CALIBRATION DATE.....	12
5. MEASUREMENT UNCERTAINTY	16
6. TEST RESULT	17
6.1. Summary.....	17
6.2. Occupied Bandwidth Measurement.....	18
6.2.1. Test Limit	18
6.2.2. Test Procedure used.....	18
6.2.3. Test Setting.....	18
6.2.4. Test Setup	19
6.2.5. Test Result.....	20
6.3. Output Power Measurement.....	24
6.3.1. Test Limit	24
6.3.2. Test Procedure Used	24
6.3.3. Test Setting.....	24
6.3.4. Test Setup	25

6.3.5.	Test Result.....	26
6.4.	Power Spectral Density Measurement.....	27
6.4.1.	Test Limit	27
6.4.2.	Test Procedure Used	27
6.4.3.	Test Setting.....	27
6.4.4.	Test Setup	27
6.4.5.	Test Result.....	28
6.5.	Conducted Band Edge and Out-of-Band Emissions	30
6.5.1.	Test Limit	30
6.5.2.	Test Procedure Used	30
6.5.3.	Test Setting.....	30
6.5.4.	Test Setup	31
6.5.5.	Test Result.....	32
6.6.	Radiated Spurious Emission Measurement	36
6.6.1.	Test Limit	36
6.6.2.	Test Procedure Used	36
6.6.3.	Test Setting.....	36
6.6.4.	Test Setup	38
6.6.5.	Test Result.....	39
6.7.	Radiated Restricted Band Edge Measurement.....	47
6.7.1.	Test Limit	47
6.7.2.	Test Procedure Used	50
6.7.3.	Test Setting.....	50
6.7.4.	Test Setup	51
6.7.5.	Test Result.....	52
6.8.	AC Conducted Emissions Measurement	68
6.8.1.	Test Limit	68
6.8.2.	Test Setup	68
6.8.3.	Test Result.....	69
7.	CONCLUSION	71
	Appendix A - Test Setup Photograph	72
	Appendix B - EUT Photograph.....	73

1. General Information

1.1. Applicant

Askey Computer Corp.
10F, No.119, JIANKANG RD., ZHONGHE DIST., NEW TAIPEI CITY, TAIWAN

1.2. Manufacturer

Askey Computer Corp.
10F, No.119, JIANKANG RD., ZHONGHE DIST., NEW TAIPEI CITY, TAIWAN

1.3. Testing Facility

☒	<p>Test Site – MRT Suzhou Laboratory</p> <p>Laboratory Location (Suzhou - Wuzhong) D8 Building, No.2 Tian’edang Rd., Wuzhong Economic Development Zone, Suzhou, China</p> <p>Laboratory Location (Suzhou - SIP) 4b Building, Liando U Valley, No.200 Xingpu Rd., Shengpu Town, Suzhou Industrial Park, China</p> <p>Laboratory Accreditations</p> <table data-bbox="248 1108 1477 1261"> <tr> <td>A2LA: 3628.01</td> <td>CNAS: L10551</td> </tr> <tr> <td>FCC: CN1166</td> <td>ISED: CN0001</td> </tr> <tr> <td colspan="2">VCCI: R-20025, G-20034, C-20020, T-20020</td> </tr> </table>	A2LA: 3628.01	CNAS: L10551	FCC: CN1166	ISED: CN0001	VCCI: R-20025, G-20034, C-20020, T-20020	
A2LA: 3628.01	CNAS: L10551						
FCC: CN1166	ISED: CN0001						
VCCI: R-20025, G-20034, C-20020, T-20020							
☐	<p>Test Site – MRT Shenzhen Laboratory</p> <p>Laboratory Location (Shenzhen) 1G, Building A, Junxiangda Building, Zhongshanyuan Road West, Nanshan District, Shenzhen, China</p> <p>Laboratory Accreditations</p> <table data-bbox="248 1473 1477 1572"> <tr> <td>A2LA: 3628.02</td> <td>CNAS: L10551</td> </tr> <tr> <td>FCC: CN1284</td> <td>ISED: CN0105</td> </tr> </table>	A2LA: 3628.02	CNAS: L10551	FCC: CN1284	ISED: CN0105		
A2LA: 3628.02	CNAS: L10551						
FCC: CN1284	ISED: CN0105						
☐	<p>Test Site – MRT Taiwan Laboratory</p> <p>Laboratory Location (Taiwan) No. 38, Fuxing 2nd Rd., Guishan Dist., Taoyuan City 333, Taiwan (R.O.C.)</p> <p>Laboratory Accreditations</p> <table data-bbox="248 1787 1477 1879"> <tr> <td>TAF: L3261-190725</td> <td></td> </tr> <tr> <td>FCC: 291082, TW3261</td> <td>ISED: TW3261</td> </tr> </table>	TAF: L3261-190725		FCC: 291082, TW3261	ISED: TW3261		
TAF: L3261-190725							
FCC: 291082, TW3261	ISED: TW3261						

2. PRODUCT INFORMATION

2.1. Equipment Description

Product Name	WIFI+BT Combo Module
Model No.	8822CS
PMN & HVIN	8822CS
Brand Name	ASKEY
Wi-Fi Specification	802.11a/b/g/n/ac
Bluetooth Specification	V5.0 dual mode
Serial No.	Conducted: 41BCK037993 F00 Radiated: 41BCK038024 F00 AC Conducted Emission: 41BCK038024 F00

2.2. Product Specification Subjective to this Report

Frequency Range	2402~2480MHz
Channel Number	40
Type of Modulation	GFSK
Data Rate	1Mbps & 2Mbps

Note: For other features of this EUT, test report will be issued separately.

2.3. Working Frequencies for this report

Channel	Frequency	Channel	Frequency	Channel	Frequency
00	2402 MHz	01	2404 MHz	02	2406 MHz
03	2408 MHz	04	2410 MHz	05	2412 MHz
06	2414 MHz	07	2416 MHz	08	2418 MHz
09	2420 MHz	10	2422 MHz	11	2424 MHz
12	2426 MHz	13	2428 MHz	14	2430 MHz
15	2432 MHz	16	2434 MHz	17	2436 MHz
18	2438 MHz	19	2440 MHz	20	2442 MHz
21	2444 MHz	22	2446 MHz	23	2448 MHz
24	2450 MHz	25	2452 MHz	26	2454 MHz
27	2456 MHz	28	2458 MHz	29	2460 MHz
30	2462 MHz	31	2464 MHz	32	2466 MHz
33	2468 MHz	34	2470 MHz	35	2472 MHz
36	2474 MHz	37	2476 MHz	38	2478 MHz
39	2480 MHz	--	--	--	--

2.4. Description of Available Antennas

Antenna Type	Frequency Band (GHz)	Tx Paths	Per Chain Max Antenna Gain (dBi)		CDD Directional Gain (dBi)	
			Ant 0	Ant 1	For Power	For PSD
Wi-Fi Internal Antenna						
PIFA	2412 ~ 2462	2	2.1	1.9	2.1	5.11
	5180 ~ 5240	2	4.2	1.9	4.2	7.21
	5260 ~ 5320	2	3.8	3.0	3.8	6.81
	5500 ~ 5720	2	3.8	2.9	3.8	6.81
	5745 ~ 5825	2	3.4	2.3	3.4	6.41
Bluetooth Internal Antenna						
PIFA	2402 ~ 2480	1	1.9		--	

Note 1:

The EUT supports Cyclic Delay Diversity (CDD) technology and CDD signals are correlated.

For CDD transmissions, directional gain is calculated as follows, $N_{ANT} = 2$, $N_{SS} = 1$.

If all antennas have the same gain, G_{ANT} , Directional gain = $G_{ANT} + \text{Array Gain}$, where Array Gain is as follows.

- For power spectral density (PSD) measurements on all devices,
Array Gain = $10 \log (N_{ANT}/ N_{SS}) \text{ dB} = 3.01$;
- For power measurements on IEEE 802.11 devices,
Array Gain = 0 dB for $N_{ANT} \leq 4$;

If antenna gains are not equal, Directional gain may be calculated by using the formulas applicable to equal gain antennas with G_{ANT} set equal to the gain of the antenna having the highest gain.

Note 2: All information was provided by manufacturer.

2.5. Description of Antenna

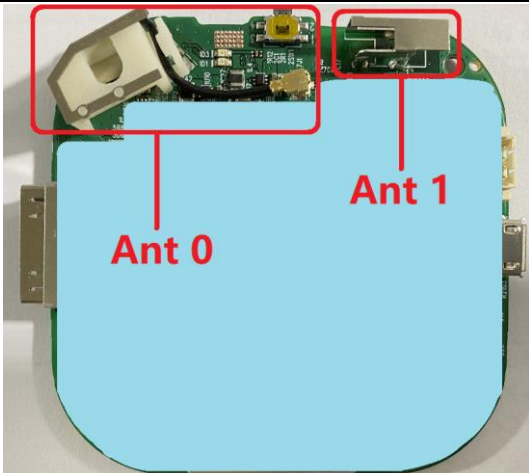
Wi-Fi & Bluetooth Antenna		
Software Control Port	Ant 0 (Wi-Fi)	Ant 1 (Wi-Fi & Bluetooth)
		
Note: A temporary RF connector to test conveniently in Ant 1 was provided by manufacturer.		

2.6. Test Mode

Test Mode	Mode 1: Transmit by BLE-1Mbps
	Mode 2: Transmit by BLE-2Mbps

Note: EUT is as a stand-alone device when the test is processing, but a test fixture will be used as a tool.

2.7. Configuration of Test System

The measurement procedures and appropriate EUT setup described in the American National Standard of Procedures for Compliance Testing of Unlicensed Wireless Devices (ANSI C63.10-2013) was used in the measurement.

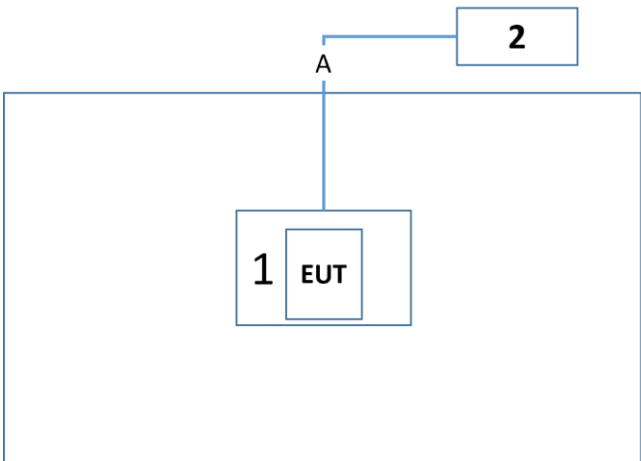
Connection Diagram	
	
Cable Type	Cable Description
A USB Cable	Shielded, <1.5m

2.8. Test System Details

The types for all equipments, plus descriptions of all cables used in the tested system (including inserted cards) are:

Product	Manufacturer	Model No.	Serial No.	Description
1 Test Fixture	ASKEY	N/A	N/A	As a power and signal control board
2 Notebook	DELL	P62G	NA	Non-Shielded, >1.8m

2.9. Test Software

The test utility software used during testing was “Realtek Bluetooth RF Test Tool”, and the RTLBTAPP version was 5.2.2.34.

2.10. Test Environment Condition

Ambient Temperature	15°C~35°C
Relative Humidity	20%RH ~75%RH

2.11. Duty Cycle

Bluetooth-LE (DTS) operation is possible in channel bandwidths. The maximum achievable duty cycles for all modes were determined based on measurements performed on a spectrum analyzer in zero-span mode with RBW = 8MHz, VBW = 50MHz. The RBW and VBW were both greater than $50/T$, where T is the minimum transmission duration, and the number of sweep points across T was greater than 100. The duty cycles are as follows:

Test Mode	Duty Cycle
BLE-1Mbps	62.81%
BLE-2Mbps	33.01%

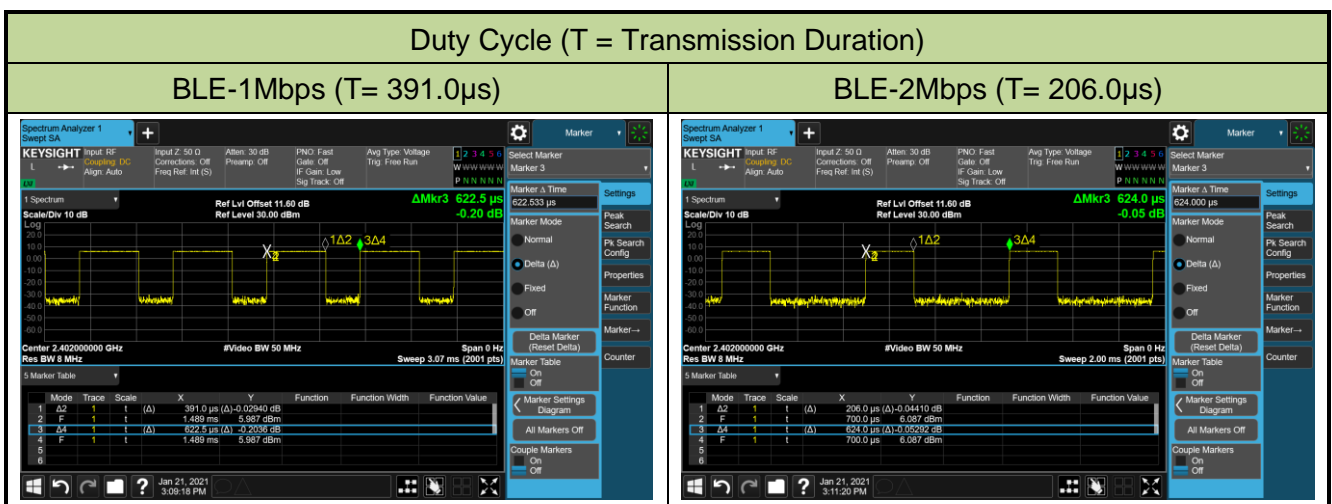

2.12. EMI Suppression Device(s)/Modifications

No EMI suppression device(s) were added and/or no modifications were made during testing.

2.13. Labeling Requirements

Per 2.1074 & 15.19; Docket 95-19

The label shall be permanently affixed at a conspicuous location on the device; instruction manual or pamphlet supplied to the user and be readily visible to the purchaser at the time of purchase.

However, when the device is so small wherein placement of the label with specified statement is not practical, only the FCC ID must be displayed on the device per Section 15.19(a)(5). Please see attachment for FCC ID label and label location.

RSS-Gen Issue 5 Section 4

In addition to complying with the applicable RSSs and RSP-100, each unit of a product model (i.e. of a radio apparatus) shall meet the labelling requirements set out in this section prior to being marketed in Canada or imported into Canada.

For information regarding the labelling option, see Section 4.1, 4.2, 4.3 4.4. The label for the certified product represents the manufacturer's or importer's compliance with Innovation, Science and Economic Development Canada's (ISED) regulatory requirements.

Please see attachment for IC label and label location.

3. ANTENNA REQUIREMENTS

Excerpt from §15.203 of the FCC Rules/Regulations:

“An intentional radiator antenna shall be designed to ensure that no antenna other than that furnished by the responsible party can be used with the device. The use of a permanently attached antenna or of an antenna that uses a unique coupling to the intentional radiator shall be considered sufficient to comply with the provisions of this section.”

Conclusion:

The unit complies with the requirement of §15.203.

4. TEST EQUIPMENT CALIBRATION DATE

Conducted Emission (WZ-SR2)

Instrument	Manufacturer	Type No.	Asset No.	Cali. Interval	Cali. Due Date
EMI Test Receiver	R&S	ESR3	MRTSUE06185	1 year	2022/01/12
Two-Line V-Network	R&S	ENV216	MRTSUE06002	1 year	2021/09/09
Thermal Hygrometer	testo	608-H1	MRTSUE06404	1 year	2021/07/26
Shielding Room	MIX-BEP	Chamber-SR2	MRTSUE06215	N/A	N/A

Conducted Emission (SIP-SR2)

Instrument	Manufacturer	Type No.	Asset No.	Cali. Interval	Cali. Due Date
EMI Test Receiver	R&S	ESR3	MRTSUE06613	1 year	2021/07/02
Two-Line V-Network	R&S	ENV216	MRTSUE06003	1 year	2021/09/09
Thermal Hygrometer	testo	608-H1	MRTSUE06621	1 year	2021/12/03

Radiated Emission (WZ-AC1)

Instrument	Manufacturer	Type No.	Asset No.	Cali. Interval	Cali. Due Date
EMI Test Receiver	R&S	ESR7	MRTSUE06001	1 year	2022/01/04
PXA Signal Analyzer	Keysight	N9030B	MRTSUE06395	1 year	2021/08/30
Loop Antenna	Schwarzbeck	FMZB 1519	MRTSUE06025	1 year	2021/11/08
Bilog Period Antenna	Schwarzbeck	VULB 9168	MRTSUE06172	1 year	2021/08/08
Horn Antenna	Schwarzbeck	BBHA 9120D	MRTSUE06023	1 year	2021/09/27
Horn Antenna	Schwarzbeck	BBHA9170	MRTSUE06597	1 year	2021/12/14
Microwave System Amplifier	Agilent	83017A	MRTSUE06076	1 year	2021/11/14
Preamplifier	Schwarzbeck	BBV 9721	MRTSUE06121	1 year	2021/06/11
Thermal Hygrometer	testo	608-H1	MRTSUE06403	1 year	2021/07/26
Anechoic Chamber	TDK	Chamber-AC1	MRTSUE06212	1 year	2021/04/30

Radiated Emission (WZ-AC2)

Instrument	Manufacturer	Type No.	Asset No.	Cali. Interval	Cali. Due Date
MXE EMI Receiver	Keysight	N9038A	MRTSUE06125	1 year	2021/07/02
Loop Antenna	Schwarzbeck	FMZB 1519	MRTSUE06025	1 year	2021/11/08
Bilog Period Antenna	Schwarzbeck	VULB 9162	MRTSUE06022	1 year	2021/05/26
Broad-Band Horn Antenna	Schwarzbeck	BBHA 9120D	MRTSUE06171	1 year	2021/10/25
Horn Antenna	Schwarzbeck	BBHA9170	MRTSUE06597	1 year	2021/12/14
Broadband Coaxial Preamplifier	Schwarzbeck	BBV 9718	MRTSUE06176	1 year	2021/11/14
Preamplifier	Schwarzbeck	BBV 9721	MRTSUE06121	1 year	2021/06/11
Thermal Hygrometer	Minggao	ETH529	MRTSUE06170	1 year	2021/12/08
Anechoic Chamber	RIKEN	Chamber-AC2	MRTSUE06213	1 year	2021/04/30

Radiated Emission (SIP-AC1)

Instrument	Manufacturer	Type No.	Asset No.	Cali. Interval	Cali. Due Date
EMI Test Receiver	R&S	ESR3	MRTSUE06612	1 year	2021/07/02
EXA Signal Analyzer	Keysight	N9010B	MRTSUE06559	1 year	2021/07/23
Loop Antenna	Schwarzbeck	FMZB 1519	MRTSUE06025	1 year	2021/11/08
Bilog Period Antenna	Schwarzbeck	VULB9168	MRTSUE06645	1 year	2021/08/30
Double Ridged Horn Antenna	R&S	HF907	MRTSUE06610	1 year	2021/08/30
Preamplifier	EMCI	EMC051845SE	MRTSUE06600	1 year	2021/11/12
Thermal Hygrometer	testo	608-H1	MRTSUE06620	1 year	2021/12/03
Anechoic Chamber	RIKEN	SIP-AC1	MRTSUE06554	1 year	2021/12/24

Radiated Emission (SIP-AC2)

Instrument	Manufacturer	Type No.	Asset No.	Cali. Interval	Cali. Due Date
EMI Test Receiver	R&S	ESR3	MRTSUE06613	1 year	2021/07/02
MXA Signal Analyzer	Keysight	N9020B	MRTSUE06604	1 year	2021/09/26
Loop Antenna	Schwarzbeck	FMZB 1519	MRTSUE06025	1 year	2021/11/08
Bilog Period Antenna	Schwarzbeck	VULB9168	MRTSUE06646	1 year	2021/08/30
Horn Antenna	Schwarzbeck	BBHA9120D	MRTSUE06648	1 year	2021/11/26
Horn Antenna	Schwarzbeck	BBHA9170	MRTSUE06599	1 year	2021/11/26
Preamplifier	EMCI	EMC051845SE	MRTSUE06644	1 year	2021/11/12
Preamplifier	EMCI	EMC184045SE	MRTSUE06602	1 year	2021/10/13
Thermal Hygrometer	testo	608-H1	MRTSUE06624	1 year	2021/12/03
Anechoic Chamber	RIKEN	SIP-AC2	MRTSUE06781	1 year	2021/12/24

Radiated Emission (SIP-AC3)

Instrument	Manufacturer	Type No.	Asset No.	Cali. Interval	Cali. Due Date
EMI Test Receiver	R&S	ESR3	MRTSUE06612	1 year	2021/07/02
EXA Signal Analyzer	Keysight	N9010B	MRTSUE06559	1 year	2021/07/23
Loop Antenna	Schwarzbeck	FMZB 1519	MRTSUE06025	1 year	2021/11/08
Bilog Period Antenna	Schwarzbeck	VULB9168	MRTSUE06647	1 year	2021/08/08
Double Ridged Horn Antenna	R&S	HF907	MRTSUE06611	1 year	2021/09/13
Horn Antenna	Schwarzbeck	BBHA9170	MRTSUE06598	1 year	2021/11/26
Preamplifier	EMCI	EMC012645SE	MRTSUE06642	1 year	2022/01/14
Preamplifier	EMCI	EMC184045SE	MRTSUE06641	1 year	2022/01/14
Thermal Hygrometer	testo	608-H1	MRTSUE06622	1 year	2021/12/03
Anechoic Chamber	RIKEN	SIP-AC3	MRTSUE06782	1 year	2021/12/24

Conducted Test Equipment (WZ-TR3)

Instrument	Manufacturer	Type No.	Asset No.	Cali. Interval	Cali. Due Date
EXA Signal Analyzer	Agilent	N9020A	MRTSUE06106	1 year	2021/04/14
EXA Signal Analyzer	Keysight	N9010B	MRTSUE06607	1 year	2022/01/07
Signal Analyzer	R&S	FSV40	MRTSUE06218	1 year	2021/04/14
Power Meter	Agilent	U2021XA	MRTSUE06030	1 year	2021/10/22
USB wideband power sensor	Keysight	U2021XA	MRTSUE06446	1 year	2021/08/30
USB wideband power sensor	Keysight	U2021XA	MRTSUE06447	1 year	2021/08/08
Bluetooth Test Set	Anritsu	MT8852B-042	MRTSUE06389	1 year	2021/06/11
Audio Analyzer	Agilent	U8903B	MRTSUE06143	1 year	2021/06/11
Modulation Analyzer	HP	HP8901A	MRTSUE06098	1 year	2021/09/26
Wideband Radio Communication Tester	R&S	CMW 500	MRTSUE06243	1 year	2021/10/20
Attenuator	MVE	3dB	MRTSUE06529	1 year	2021/12/12
Attenuator	MVE	6dB	MRTSUE06534	1 year	2021/12/12
Attenuator	MVE	10dB	MRTSUE06540	1 year	2021/12/12
Attenuator	MVE	20dB	MRTSUE06547	1 year	2021/12/12
DC Power Supply	GWINSTEK	DPS-3303C	MRTSUE06064	N/A	N/A
Temperature & Humidity Chamber	BAOYT	BYH-150CL	MRTSUE06051	1 year	2021/10/22
Thermal Hygrometer	testo	608-H1	MRTSUE06401	1 year	2021/07/26

Conducted Test Equipment (SIP-SR5)

Instrument	Manufacturer	Type No.	Asset No.	Cali. Interval	Cali. Due Date
Signal Analyzer	R&S	FSV40	MRTSUE06218	1 year	2021/04/14
PXA Signal Analyzer	Keysight	N9030B	MRTSUE06395	1 year	2021/08/30
USB wideband power sensor	Agilent	U2021XA	MRTSUE06595	1 year	2021/09/26
USB wideband power sensor	Agilent	U2021XA	MRTSUE06596	1 year	2021/09/26
Wideband Radio Communication Tester	R&S	CMW 500	MRTSUE06243	1 year	2021/10/20
Bluetooth Test Set	Anritsu	MT8852B-042	MRTSUE06389	1 year	2021/06/11
Attenuator	MVE	3dB	MRTSUE06530	1 year	2021/12/12
Attenuator	MVE	6dB	MRTSUE06535	1 year	2021/12/12
Attenuator	MVE	10dB	MRTSUE06541	1 year	2021/12/12
Attenuator	MVE	20dB	MRTSUE06548	1 year	2021/12/12
Temperature Chamber	BAOYT	BYG-408CS	MRTSUE06847	1 year	2022/02/23
Thermal Hygrometer	testo	622	MRTSUE06629	1 year	2021/11/25

Software	Version	Function
EMI Software	V3	EMI Test Software

5. MEASUREMENT UNCERTAINTY

Where relevant, the following test uncertainty levels have been estimated for tests performed on the EUT as specified in CISPR 16-4-2. This uncertainty represents an expanded uncertainty expressed at approximately the 95% confidence level using a coverage factor of $k = 2$.

Conducted Emission Measurement
Measurement Uncertainty for a Level of Confidence of 95% ($U=2Uc(y)$): 9kHz~150kHz: 3.74dB 150kHz~30MHz: 3.44dB
Radiated Disturbance
Measurement Uncertainty for a Level of Confidence of 95% ($U=2Uc(y)$): Horizontal: 9KHz~300MHz: 5.04dB 300MHz~1GHz: 4.95dB 1GHz~6GHz: 6.40dB Vertical: 9KHz~300MHz: 5.24dB 300MHz~1GHz: 6.03dB 1GHz~40GHz: 6.40dB
Spurious Emissions, Conducted
Measuring Uncertainty for a Level of Confidence of 95% ($U=2Uc(y)$): 0.78dB
Output Power
Measuring Uncertainty for a Level of Confidence of 95% ($U=2Uc(y)$): 1.13dB
Power Spectrum Density
Measuring Uncertainty for a Level of Confidence of 95% ($U=2Uc(y)$): 1.15dB
Occupied Bandwidth
Measuring Uncertainty for a Level of Confidence of 95% ($U=2Uc(y)$): 0.28%

6. TEST RESULT

6.1. Summary

FCC Section(s)	ISED Section(s)	Test Description	Test Limit	Test Condition	Test Result	Reference
15.247(a)(2)	RSS-247 [5.2]	6dB Bandwidth	$\geq 500\text{kHz}$	Conducted	Pass	Section
N/A	RSS-Gen [6.7]	99% Bandwidth	N/A		Pass	6.2
15.247(b)(3)	RSS-247 [5.4(d)]	Output Power	$\leq 1\text{Watt (30dBm)}$ & $\text{EIRP} \leq 4\text{Watt (36dBm)}$		Pass	Section 6.3
15.247(e)	RSS-247 [5.2]	Power Spectral Density	$\leq 8\text{dBm/3kHz}$		Pass	Section 6.4
15.247(d)	RSS-247 [5.5]	Band Edge / Out-of-Band Emissions	20dBc		Pass	Section 6.5
15.205 15.209	RSS-247 [5.5]	General Field Strength Limits (Restricted Bands and Radiated Emission Limits)	Emissions in restricted bands must meet the radiated limits detailed in 15.209	Radiated	Pass	Section 6.6 & 6.7
15.207	RSS-Gen [8.8]	AC Conducted Emissions 150kHz - 30MHz	$< \text{FCC 15.207 limits}$	Line Conducted	Pass	Section 6.8

Notes:

- 1) For radiated emission test, every axis (X, Y, Z) was also verified. The test results shown in the following sections represent the worst-case emissions.
- 2) The analyzer plots shown in this section were all taken with a correction table loaded into the analyzer. The correction table was used to account for the losses of the cables and attenuators used as part of the system to connect the EUT to the analyzer at all frequencies of interest.

6.2. Occupied Bandwidth Measurement

6.2.1. Test Limit

The minimum 6dB bandwidth shall be at least 500 kHz.

6.2.2. Test Procedure used

ANSI C63.10-2013 - Section 11.8 (6dB bandwidth)

ANSI C63.10-2013 - Section 6.9.3 (99% bandwidth)

6.2.3. Test Setting

For 6dB bandwidth

1. The Spectrum's automatic bandwidth measurement capability was used to perform the 6dB bandwidth measurement. The "X" dB bandwidth parameter was set to $X = 6$. The bandwidth measurement was not influenced by any intermediate power nulls in the fundamental emission.
2. Set RBW = 100 kHz
3. $VBW \geq 3 \times RBW$
4. Detector = Peak
5. Trace mode = Max hold
6. Sweep = Auto couple
7. Allow the trace was allowed to stabilize

For 99% bandwidth

1. Span = 1.5 times to 5 times the OBW
2. Set RBW = 1% to 5% the OBW
3. $VBW \geq 3 \times RBW$
4. Detector = Peak
5. Trace mode = Max hold
6. Sweep = Auto couple
7. Allow the trace was allowed to stabilize

6.2.4. Test Setup

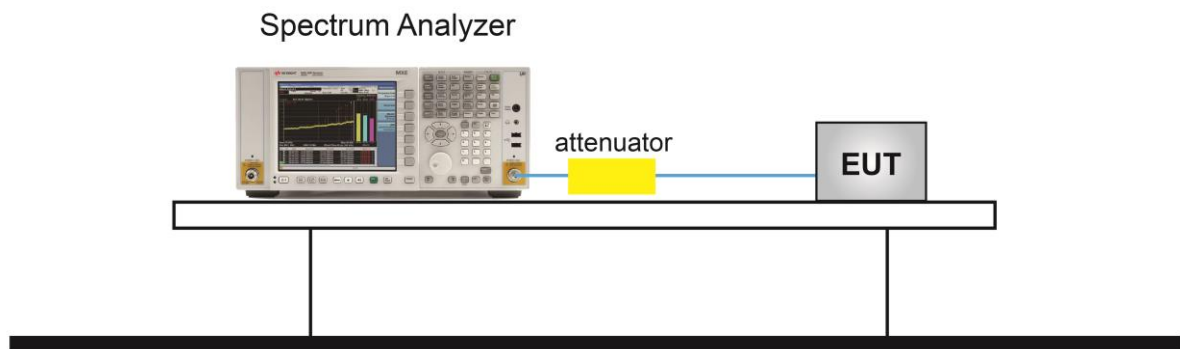

6.2.5. Test Result

Test Site	WZ-TR3	Test Engineer	Yuri Li
Test Date	2021/01/21 ~ 2021/03/04		

Test Mode	Data Rate (Mbps)	Channel No.	Frequency (MHz)	6dB Bandwidth (KHz)	Limit (kHz)	99% Bandwidth (kHz)	Result
BLE	1	00	2402	661.7	≥ 500	1034.1	Pass
BLE	1	19	2440	655.6	≥ 500	1029.7	Pass
BLE	1	39	2480	659.8	≥ 500	1029.8	Pass
BLE	2	00	2402	1129.0	≥ 500	2030.7	Pass
BLE	2	19	2440	1101.0	≥ 500	2044.4	Pass
BLE	2	39	2480	1130.0	≥ 500	2060.8	Pass

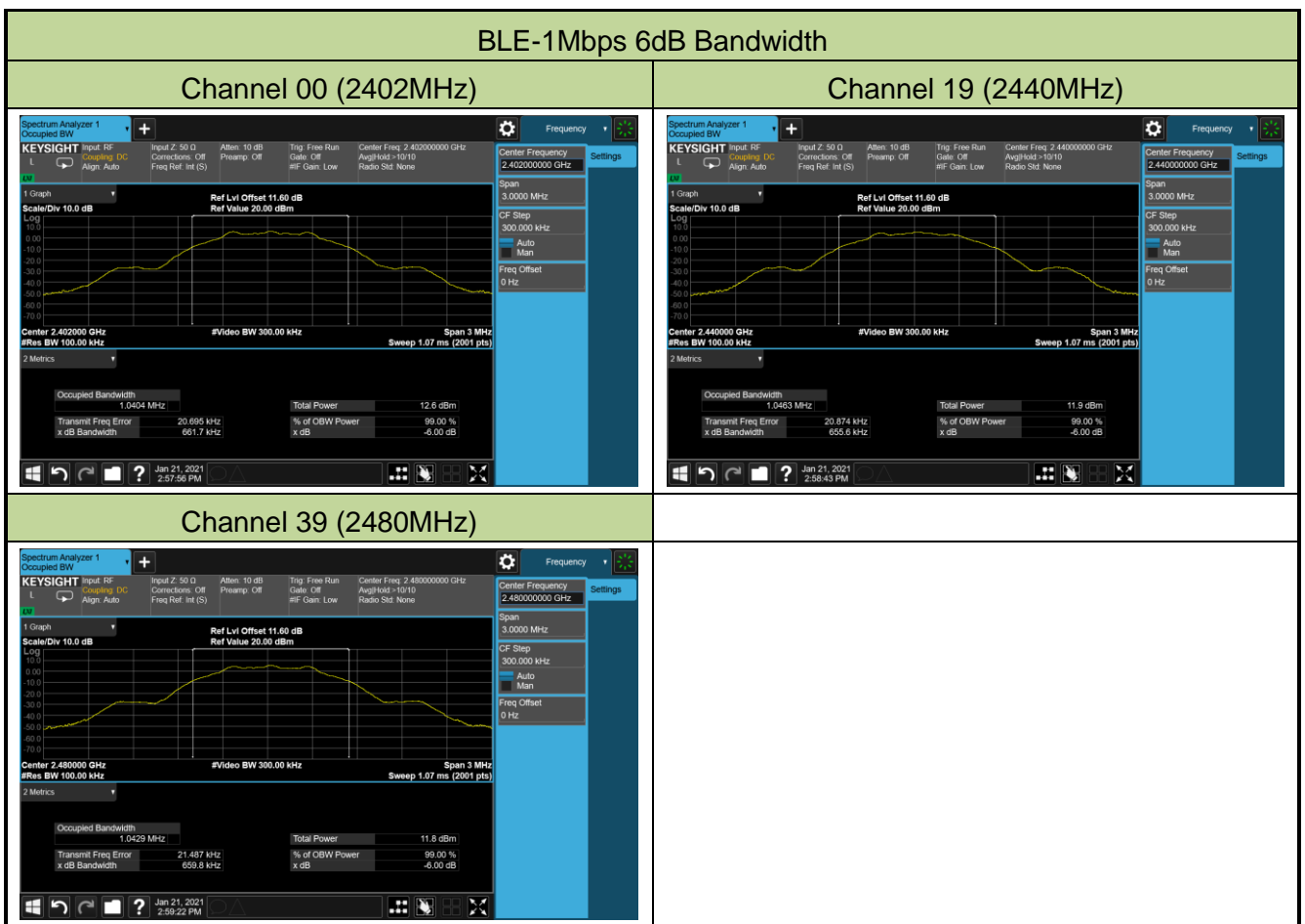

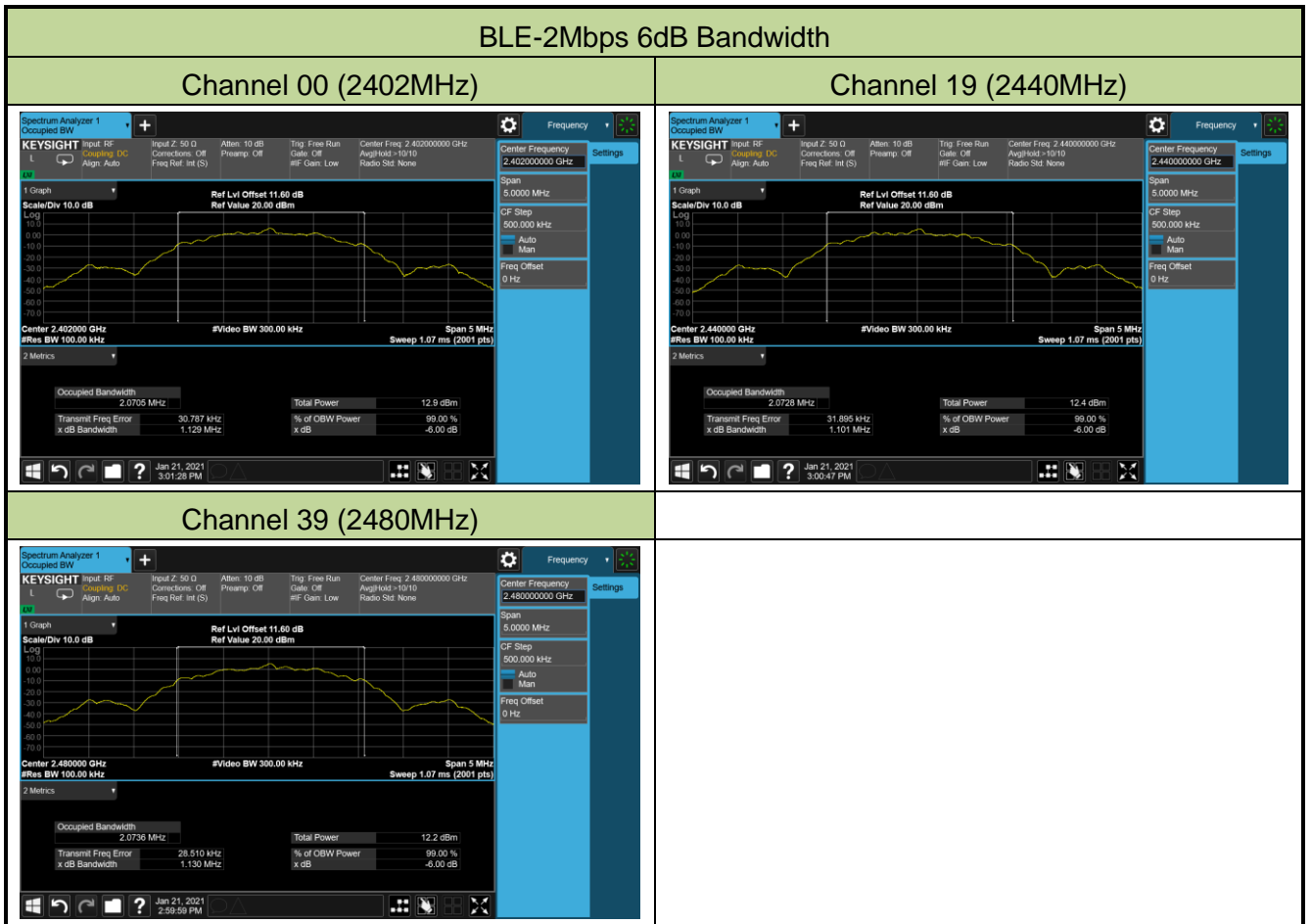





6.3. Output Power Measurement

6.3.1. Test Limit

The maximum out power shall be less 1 Watt (30dBm) and the E.I.R.P shall not exceed 4 Watt (36dBm).

The conducted output power limit specified in paragraph FCC Part 15.247(b) of this section is based on the use of antennas with directional gains that do not exceed 6 dBi. If transmitting antennas of directional gain greater than 6 dBi are used, the conducted output power from the intentional radiator shall be reduced below the stated values in paragraphs FCC Part 15.247(b)(3) of this section, as appropriate, by the amount in dB that the directional gain of the antenna exceeds 6 dBi.

6.3.2. Test Procedure Used

ANSI C63.10-2013 - Section 11.9.1.3 PKPM1 Peak-reading power meter method

ANSI C63.10-2013 - Section 11.9.2.3.2 Method AVGPM-G

6.3.3. Test Setting

Method PKPM1 (Peak power measurement)

Peak power measurements were performed only when the EUT was transmitting at its maximum power control level using a broadband power meter with a pulse sensor. The pulse sensor employs a VBW = 50MHz so this method was only used for signals whose DTS bandwidth was less than or equal to 50MHz.

Method AVGPM-G (Measurement using a gated RF average-reading power meter)

Measurements may be performed using a wideband gated RF power meter provided that the gate parameters are adjusted such that the power is measured only when the EUT is transmitting at its maximum power control level. Since this measurement is made only during the ON time of the transmitter, no duty cycle correction is required.

6.3.4. Test Setup

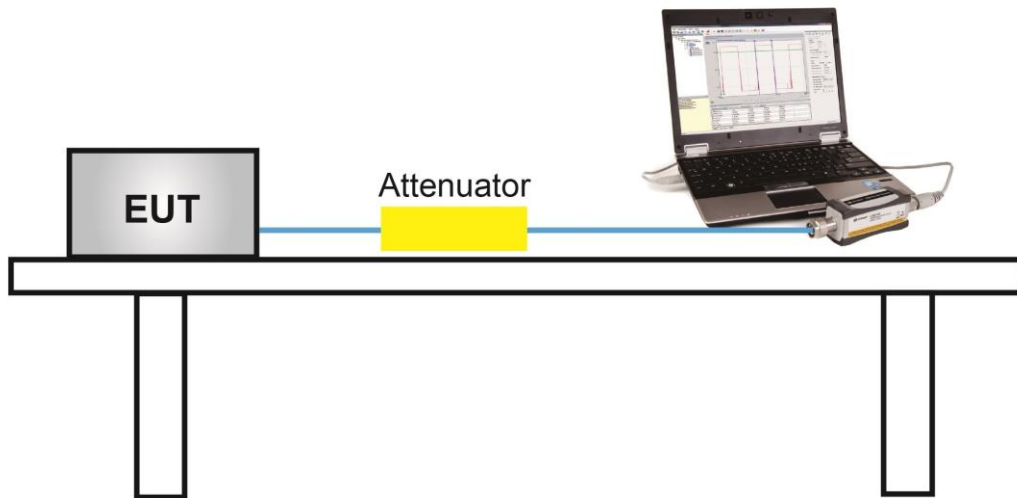

6.3.5. Test Result

Test Site	WZ-TR3	Test Engineer	Yuri Li
Test Date	2021/01/21		

Test Result of Peak Output Power

Test Mode	Data Rate (Mbps)	Channel No.	Frequency (MHz)	Peak Power (dBm)	Limit (dBm)	Max EIRP (dBm)	EIRP Limit (dBm)	Result
BLE	1	00	2402	5.78	≤ 30.00	7.68	≤ 36.00	Pass
BLE	1	19	2440	5.33	≤ 30.00	7.23	≤ 36.00	Pass
BLE	1	39	2480	5.29	≤ 30.00	7.19	≤ 36.00	Pass
BLE	2	00	2402	5.83	≤ 30.00	7.73	≤ 36.00	Pass
BLE	2	19	2440	5.42	≤ 30.00	7.32	≤ 36.00	Pass
BLE	2	39	2480	5.37	≤ 30.00	7.27	≤ 36.00	Pass

Note: Max EIRP (dBm) = Peak Power (dBm) + Antenna Gain (dBi), Antenna Gain = 1.9 dBi.

Test Result of Average Output Power (Reporting Only)

Test Mode	Data Rate (Mbps)	Channel No.	Frequency (MHz)	Average Power (dBm)	Limit (dBm)	Max EIRP (dBm)	EIRP Limit (dBm)	Result
BLE	1	00	2402	3.61	≤ 30.00	5.51	≤ 36.00	Pass
BLE	1	19	2440	3.31	≤ 30.00	5.21	≤ 36.00	Pass
BLE	1	39	2480	3.17	≤ 30.00	5.07	≤ 36.00	Pass
BLE	2	00	2402	3.73	≤ 30.00	5.63	≤ 36.00	Pass
BLE	2	19	2440	3.33	≤ 30.00	5.23	≤ 36.00	Pass
BLE	2	39	2480	3.23	≤ 30.00	5.13	≤ 36.00	Pass

Note: Max EIRP (dBm) = Average Power (dBm) + Antenna Gain (dBi), Antenna Gain = 1.9 dBi.

6.4. Power Spectral Density Measurement

6.4.1. Test Limit

The maximum permissible power spectral density is 8dBm in any 3 kHz band.

The same method of determining the conducted output power shall be used to determine the power spectral density.

6.4.2. Test Procedure Used

ANSI C63.10-2013 - Section 11.10.2.

6.4.3. Test Setting

1. Analyzer was set to the center frequency of the DTS channel under investigation
2. Span = 1.5 times the DTS channel bandwidth
3. RBW = 3kHz
4. VBW = 10kHz
5. Detector = peak
6. Sweep time = auto couple
7. Trace mode = max hold
8. Trace was allowed to stabilize

6.4.4. Test Setup

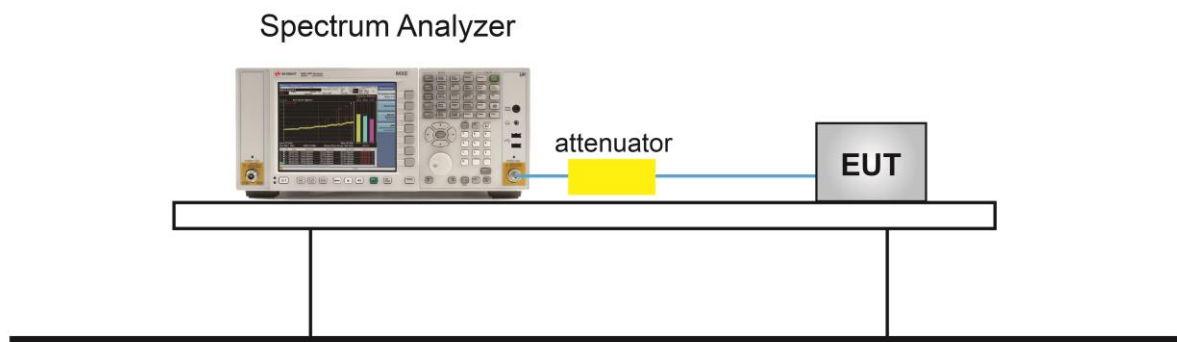

6.4.5. Test Result

Test Site	WZ-TR3	Test Engineer	Yuri Li
Test Date	2021/01/21		

Test Mode	Data Rate (Mbps)	Channel No.	Frequency (MHz)	PSD Result (dBm / 3kHz)	Limit (dBm / 3kHz)	Result
BLE	1	00	2402	-10.37	≤ 8.00	Pass
BLE	1	19	2440	-9.92	≤ 8.00	Pass
BLE	1	39	2480	-9.45	≤ 8.00	Pass
BLE	2	00	2402	-11.65	≤ 8.00	Pass
BLE	2	19	2440	-11.35	≤ 8.00	Pass
BLE	2	39	2480	-12.98	≤ 8.00	Pass

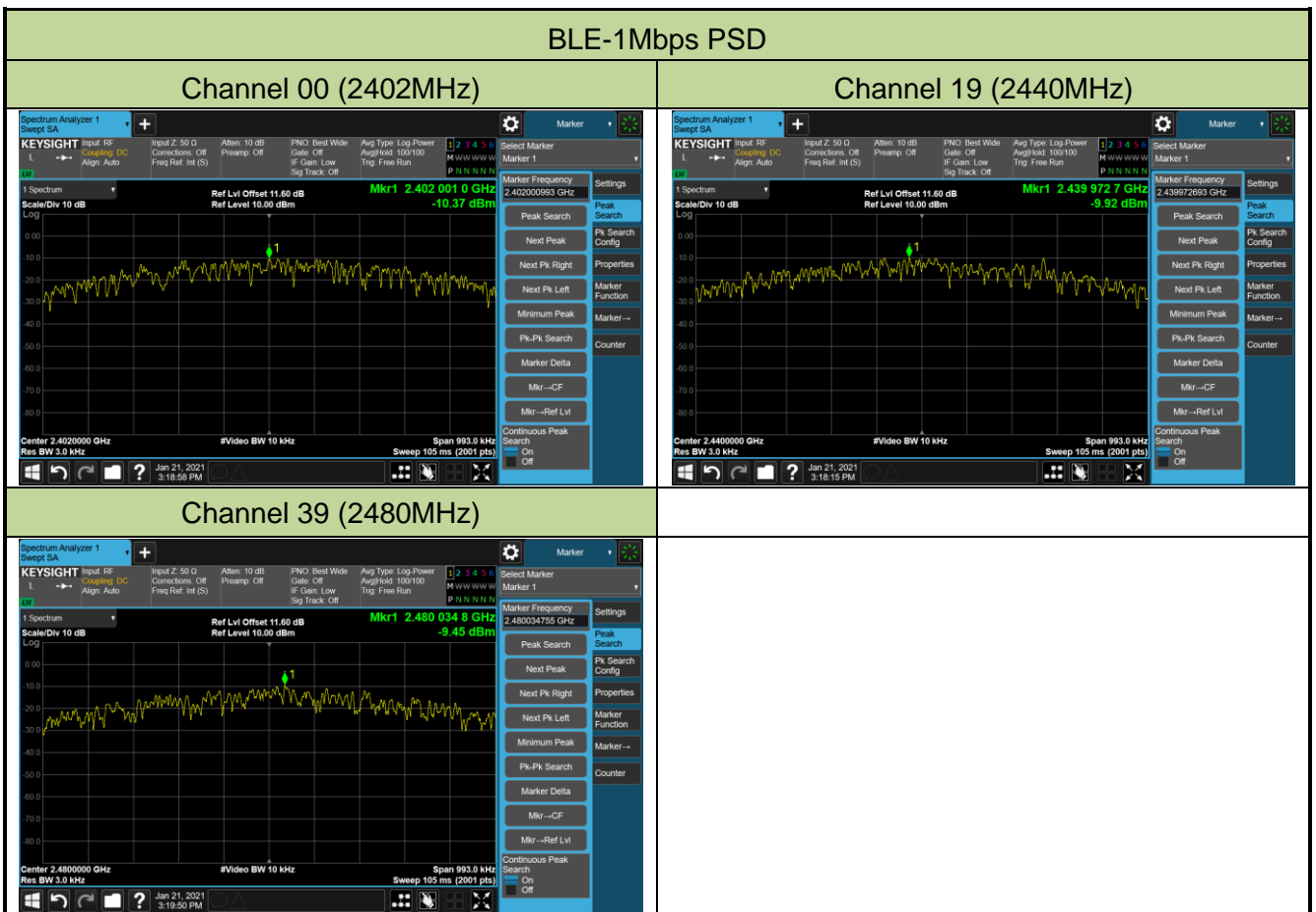

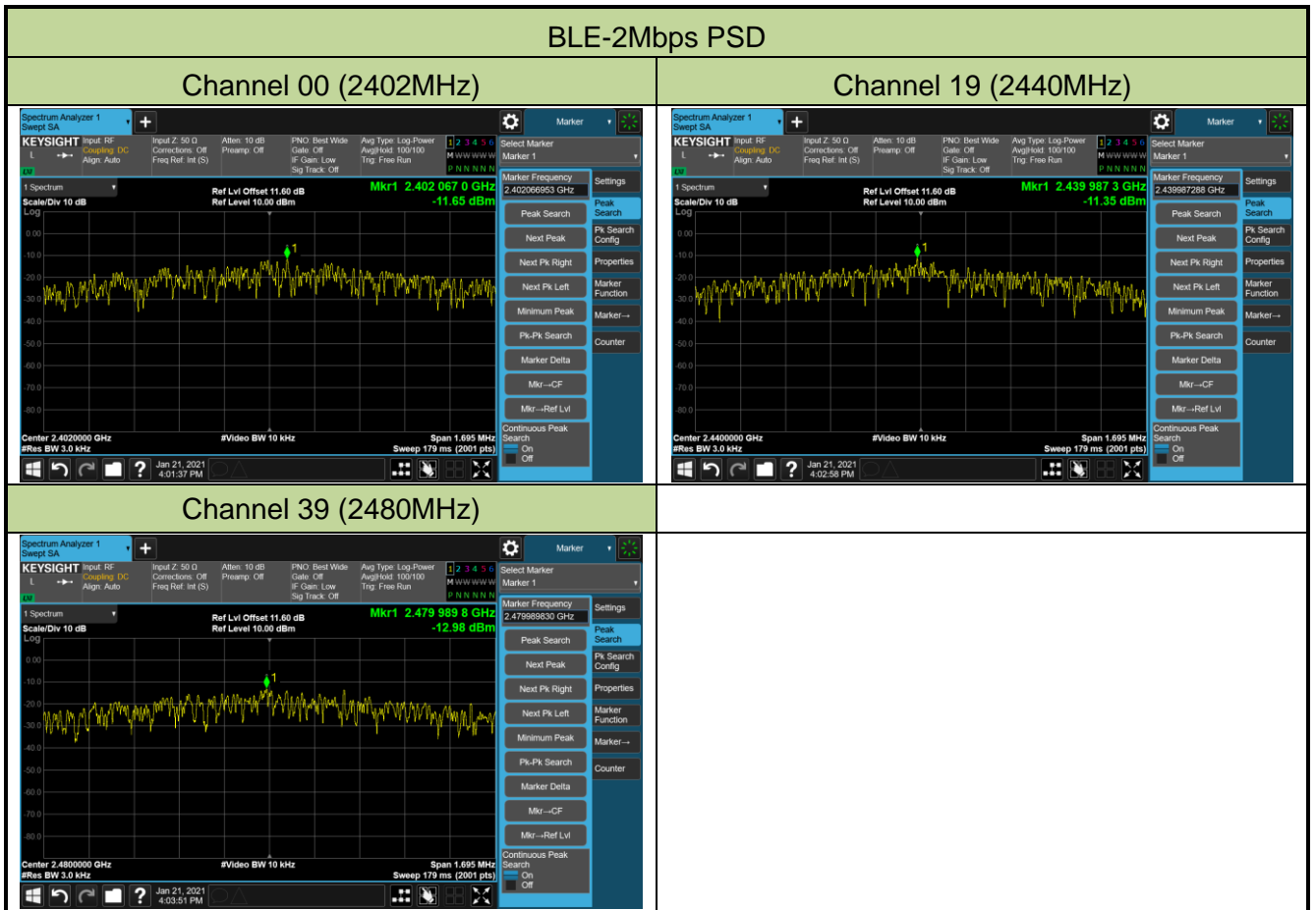

6.5. Conducted Band Edge and Out-of-Band Emissions

6.5.1. Test Limit

The limit for out-of-band spurious emissions at the band edge is 20dB below the fundamental emission level, as determined from the in-band power measurement of the DTS channel performed in a 100 kHz bandwidth per the PSD procedure.

6.5.2. Test Procedure Used

ANSI C63.10-2013 - Section 11.11.2 & 11.11.3.

6.5.3. Test Setting

Reference level measurement

1. Set instrument center frequency to DTS channel center frequency
2. Set the span to ≥ 1.5 times the DTS bandwidth
3. Set the RBW = 100 kHz
4. Set the VBW $\geq 3 \times$ RBW
5. Detector = peak
6. Sweep time = auto couple
7. Trace mode = max hold
8. Allow trace to fully stabilize

Emission level measurement

1. Set the center frequency and span to encompass frequency range to be measured
2. RBW = 100KHz
3. VBW = 300KHz
4. Detector = Peak
5. Trace mode = max hold
6. Sweep time = auto couple
7. The trace was allowed to stabilize

6.5.4. Test Setup

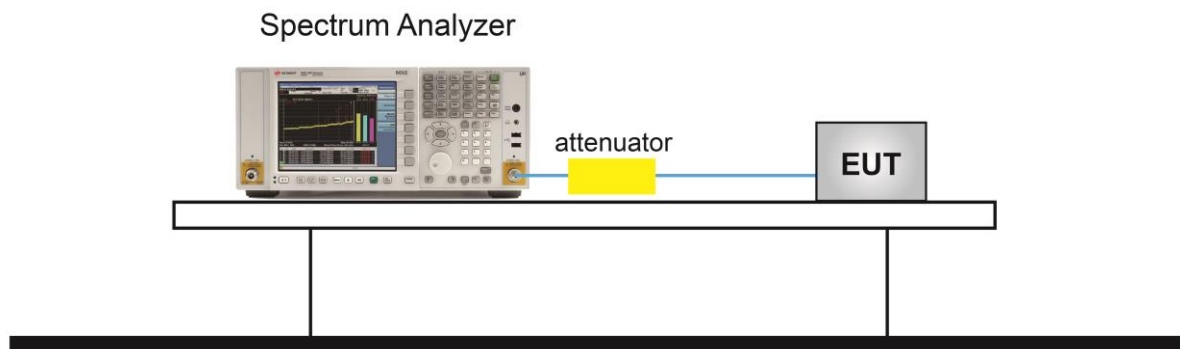

6.5.5. Test Result

Test Site	WZ-TR3	Test Engineer	Yuri Li
Test Date	2021/01/21		

Test Mode	Data Rate / Mbps	Channel No.	Frequency (MHz)	Limit (dBc)	Result
BLE	1	00	2402	20	Pass
BLE	1	19	2440	20	Pass
BLE	1	39	2480	20	Pass
BLE	2	00	2402	20	Pass
BLE	2	19	2440	20	Pass
BLE	2	39	2480	20	Pass

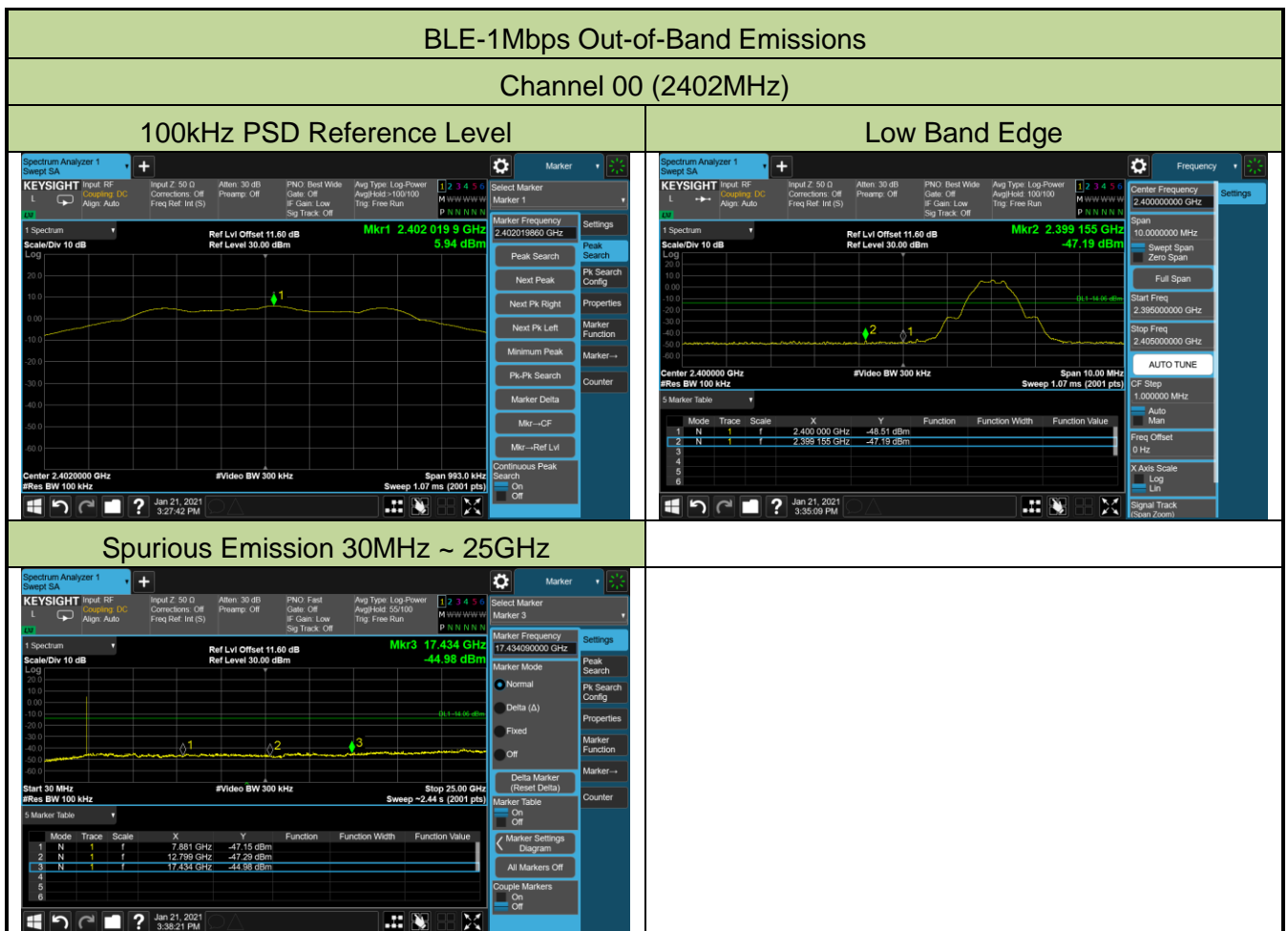

Channel 19 (2440MHz)

100kHz PSD Reference Level

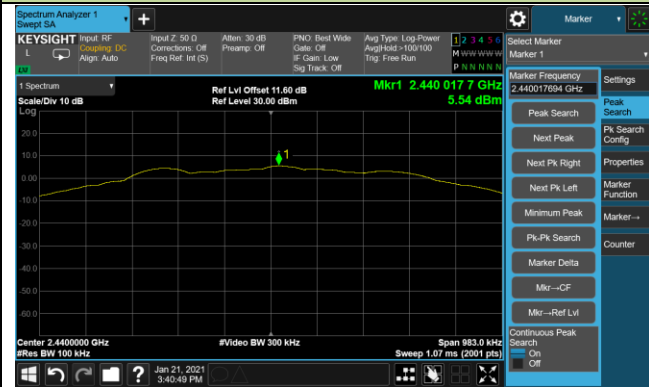

Spurious Emission 30MHz ~ 25GHz

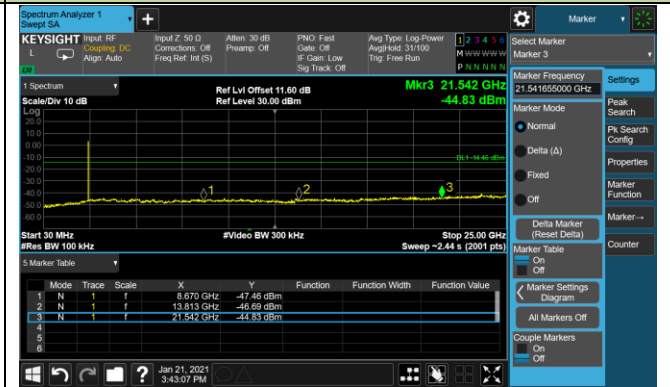

Channel 39 (2480MHz)

100kHz PSD Reference Level

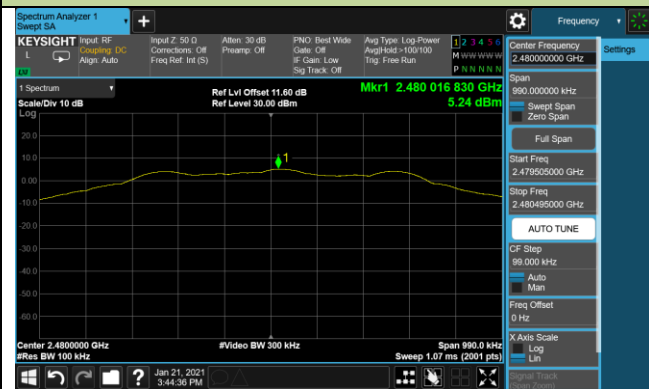

High Band Edge

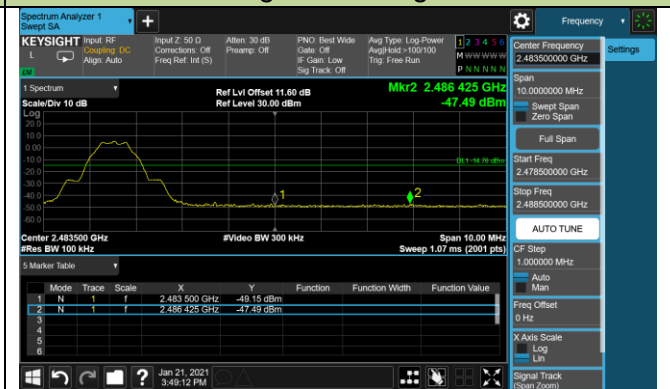

Spurious Emission 30MHz ~ 25GHz



BLE-2Mbps Out-of-Band Emissions

Channel 00 (2402MHz)

100kHz PSD Reference Level



Low Band Edge



Spurious Emission 30MHz ~ 25GHz

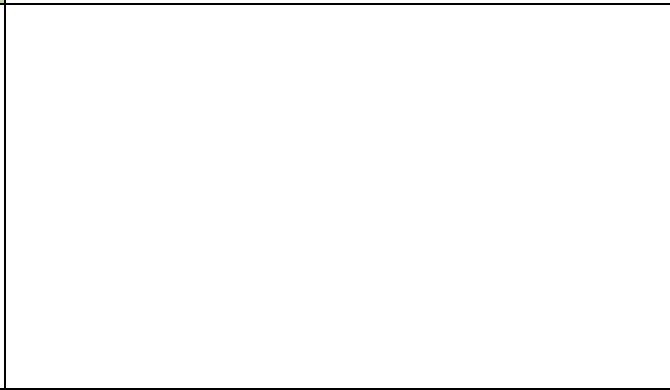
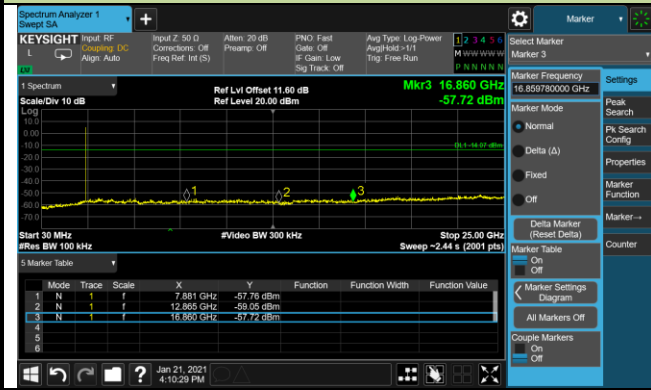

Channel 19 (2440MHz)

100kHz PSD Reference Level

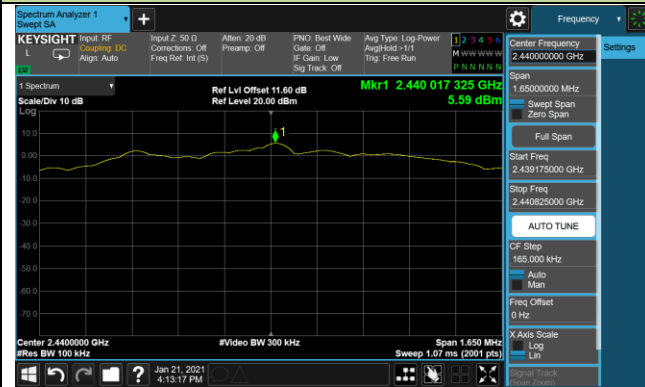

Spurious Emission 30MHz ~ 25GHz

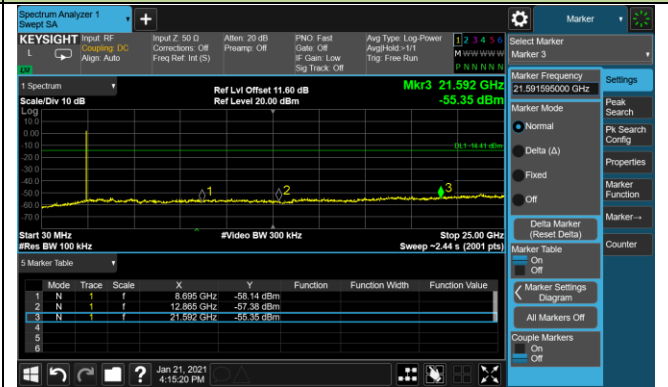

Channel 39 (2480MHz)

100kHz PSD Reference Level

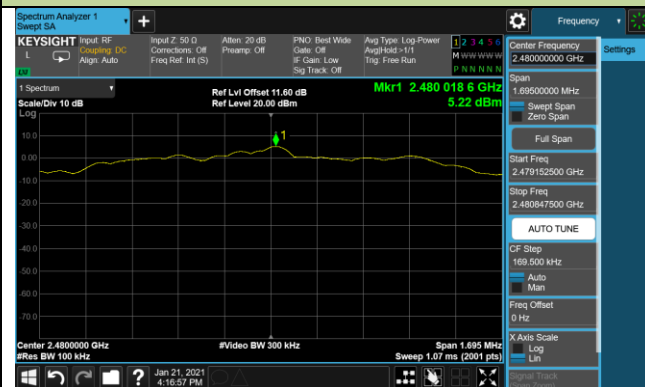

High Band Edge

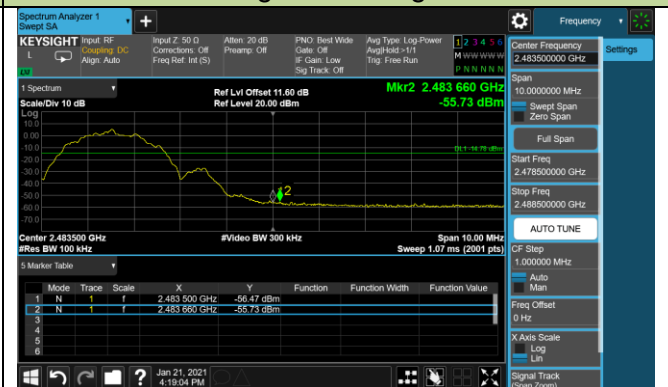

Spurious Emission 30MHz ~ 25GHz

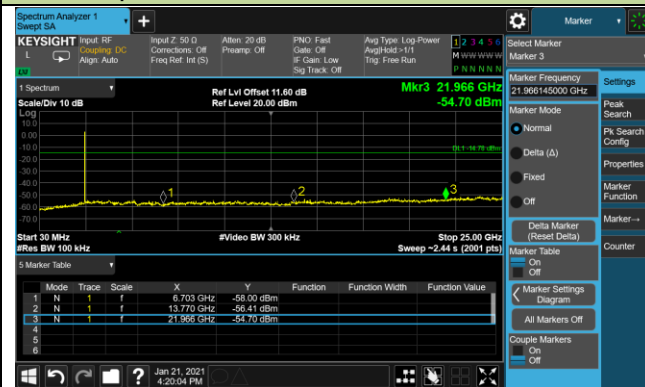

6.6. Radiated Spurious Emission Measurement

6.6.1. Test Limit

All out of band emissions appearing in a restricted band as specified in Section 15.205 of the Title 47CFR must not exceed the limits shown in Table per Section 15.209.

FCC Part 15 Subpart C Paragraph 15.209 & RSS-Gen Section 8.9		
Frequency [MHz]	Field Strength [uV/m]	Measured Distance [Meters]
0.009 - 0.490	2400/F (kHz)	300
0.490 - 1.705	24000/F (kHz)	30
1.705 - 30	30	30
30 - 88	100	3
88 - 216	150	3
216 - 960	200	3
Above 960	500	3

6.6.2. Test Procedure Used

ANSI C63.10 Section 6.3 (General Requirements)

ANSI C63.10 Section 6.4 (Standard test method below 30MHz)

ANSI C63.10 Section 6.5 (Standard test method above 30MHz to 1GHz)

ANSI C63.10 Section 6.6 (Standard test method above 1GHz)

6.6.3. Test Setting

Table 1 - RBW as a function of frequency

Frequency	RBW
9 ~ 150 kHz	200 ~ 300 Hz
0.15 ~ 30 MHz	9 ~ 10 kHz
30 ~ 1000 MHz	100 ~ 120 kHz
> 1000 MHz	1 MHz

Quasi-Peak Measurements below 1GHz

1. Analyzer center frequency was set to the frequency of the radiated spurious emission of interest
2. Span was set greater than 1MHz
3. RBW = as specified in Table 1
4. Detector = CISPR quasi-peak
5. Sweep time = auto couple
6. Trace was allowed to stabilize

Peak Measurements above 1GHz

1. Analyzer center frequency was set to the frequency of the radiated spurious emission of interest
2. RBW = 1MHz
3. VBW = 3MHz
4. Detector = peak
5. Sweep time = auto couple
6. Trace mode = max hold
7. Trace was allowed to stabilize

Average Measurements above 1GHz (Method VB)

1. Analyzer center frequency was set to the frequency of the radiated spurious emission of interest
2. RBW = 1MHz
3. VBW; If the EUT is configured to transmit with duty cycle $\geq 98\%$, set VBW = 10 Hz.
If the EUT duty cycle is $< 98\%$, set VBW $\geq 1/T$. T is the minimum transmission duration.
4. Detector = Peak
5. Sweep time = auto
6. Trace mode = max hold
7. Trace was allowed to stabilize

6.6.4. Test Setup

Below 1GHz Test Setup:

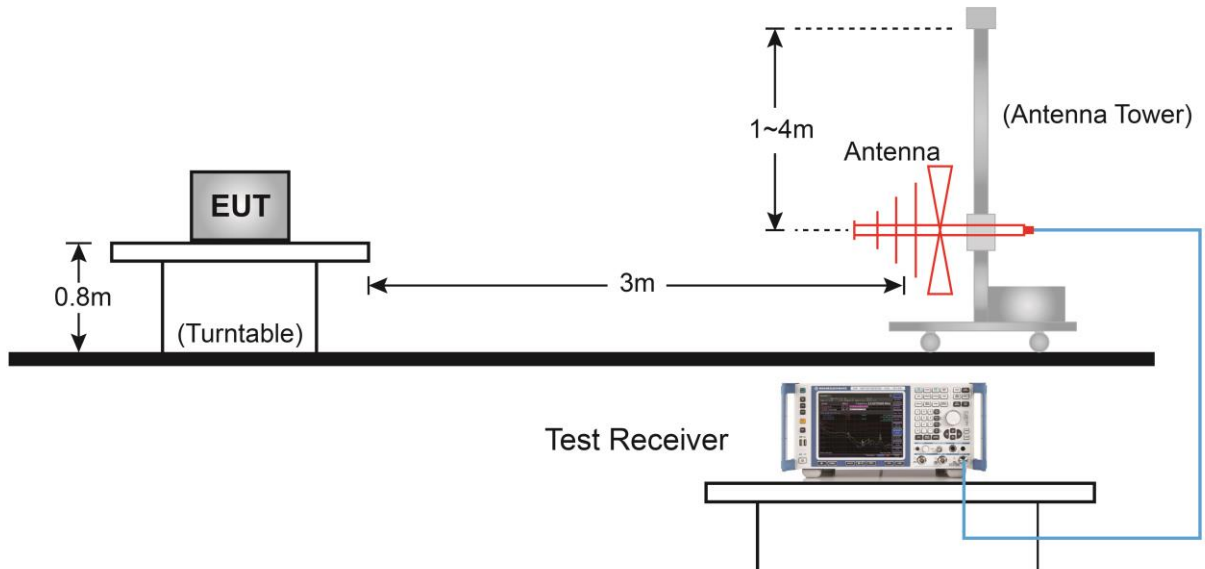

Above 1GHz Test Setup:

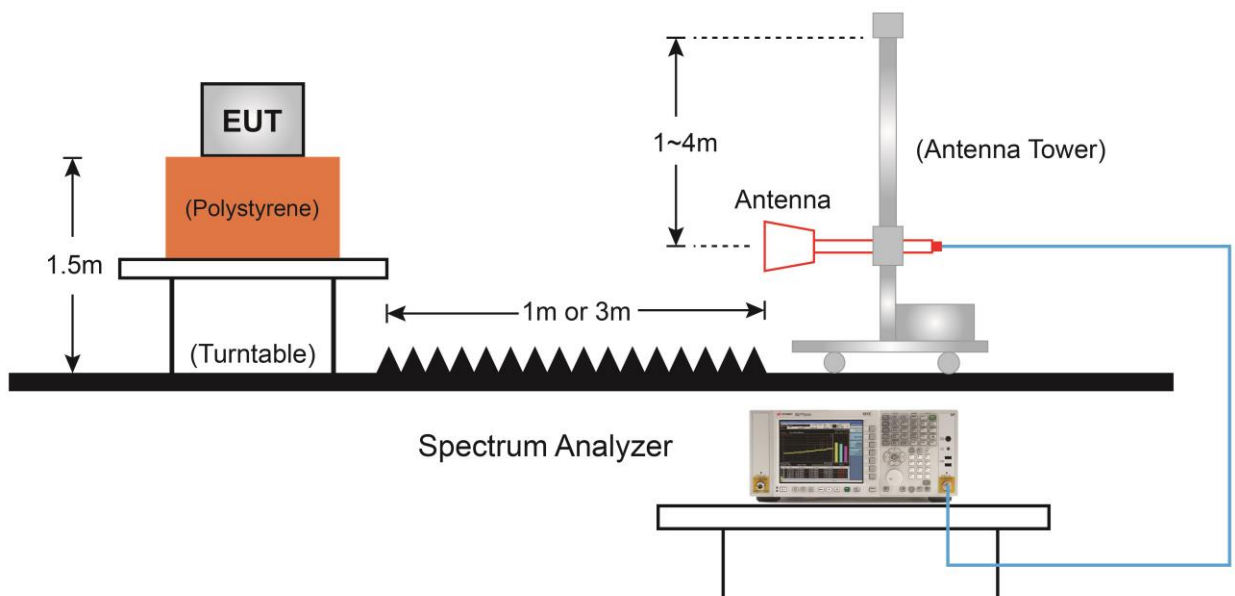

6.6.5. Test Result

Test Site	SIP-AC1	Test Engineer	Stephen Dong
Test Date	2021/02/04	Test Channel	00
Test Mode	BLE-1Mbps		
Note	1. Average measurement was not performed if peak level lower than average limit. 2. Other frequency was 20dB below limit line within 1-18GHz, there is not show in the report.		

Mark	Frequency (MHz)	Reading Level (dB μ V)	Factor (dB)	Measure Level (dB μ V/m)	Limit (dB μ V/m)	Margin (dB)	Detector	Polarization
	7596.0	51.8	-7.5	44.3	74.0	-29.7	Peak	Horizontal
	8276.0	52.3	-6.7	45.6	74.0	-28.4	Peak	Horizontal
	11667.5	51.6	-5.0	46.6	74.0	-27.4	Peak	Horizontal
	8276.0	51.4	-6.7	44.7	74.0	-29.3	Peak	Vertical
	11064.0	51.2	-5.1	46.1	74.0	-27.9	Peak	Vertical
	12305.0	50.4	-3.7	46.8	74.0	-27.2	Peak	Vertical

Note: Measure Level (dB μ V/m) = Reading Level (dB μ V) + Factor (dB)

Factor (dB) = Cable Loss (dB) + Antenna Factor (dB/m) - Pre_Amplifier Gain (dB)

Test Site	SIP-AC1	Test Engineer	Stephen Dong
Test Date	2021/02/04	Test Channel	19
Test Mode	BLE-1Mbps		
Note	1. Average measurement was not performed if peak level lower than average limit. 2. Other frequency was 20dB below limit line within 1-18GHz, there is not show in the report.		

Mark	Frequency (MHz)	Reading Level (dB μ V)	Factor (dB)	Measure Level (dB μ V/m)	Limit (dB μ V/m)	Margin (dB)	Detector	Polarization
	8386.5	50.6	-6.7	43.9	74.0	-30.1	Peak	Horizontal
	11242.5	51.9	-5.3	46.6	74.0	-27.4	Peak	Horizontal
	12075.5	50.9	-3.9	46.9	74.0	-27.1	Peak	Horizontal
	8276.0	50.8	-6.7	44.1	74.0	-29.9	Peak	Vertical
	11599.5	51.5	-4.7	46.7	74.0	-27.3	Peak	Vertical
	12271.0	51.2	-3.6	47.6	74.0	-26.4	Peak	Vertical

Note: Measure Level (dB μ V/m) = Reading Level (dB μ V) + Factor (dB)

Factor (dB) = Cable Loss (dB) + Antenna Factor (dB/m) - Pre_Amplifier Gain (dB)

Test Site	SIP-AC1	Test Engineer	Stephen Dong
Test Date	2021/02/04	Test Channel	39
Test Mode	BLE-1Mbps		
Note	1. Average measurement was not performed if peak level lower than average limit. 2. Other frequency was 20dB below limit line within 1-18GHz, there is not show in the report.		

Mark	Frequency (MHz)	Reading Level (dB μ V)	Factor (dB)	Measure Level (dB μ V/m)	Limit (dB μ V/m)	Margin (dB)	Detector	Polarization
	8242.0	51.7	-6.6	45.1	74.0	-28.9	Peak	Horizontal
	10715.5	51.9	-5.3	46.6	74.0	-27.4	Peak	Horizontal
	12016.0	50.6	-4.2	46.4	74.0	-27.6	Peak	Horizontal
	8310.0	52.4	-6.9	45.5	74.0	-28.5	Peak	Vertical
	10979.0	50.6	-5.5	45.1	74.0	-28.9	Peak	Vertical
	12169.0	50.1	-4.3	45.8	74.0	-28.2	Peak	Vertical

Note: Measure Level (dB μ V/m) = Reading Level (dB μ V) + Factor (dB)

Factor (dB) = Cable Loss (dB) + Antenna Factor (dB/m) - Pre_Amplifier Gain (dB)

Test Site	SIP-AC1	Test Engineer	Stephen Dong
Test Date	2021/02/04	Test Channel	00
Test Mode	BLE-2Mbps		
Note	1. Average measurement was not performed if peak level lower than average limit. 2. Other frequency was 20dB below limit line within 1-18GHz, there is not show in the report.		

Mark	Frequency (MHz)	Reading Level (dB μ V)	Factor (dB)	Measure Level (dB μ V/m)	Limit (dB μ V/m)	Margin (dB)	Detector	Polarization
	8293.0	51.8	-6.7	45.2	74.0	-28.8	Peak	Horizontal
	11115.0	52.0	-5.2	46.8	74.0	-27.2	Peak	Horizontal
	11931.0	51.7	-4.1	47.6	74.0	-26.4	Peak	Horizontal
	8310.0	50.5	-6.9	43.6	74.0	-30.4	Peak	Vertical
	10928.0	48.2	-5.9	42.3	74.0	-31.7	Peak	Vertical
	11769.5	50.5	-4.4	46.1	74.0	-27.9	Peak	Vertical

Note: Measure Level (dB μ V/m) = Reading Level (dB μ V) + Factor (dB)

Factor (dB) = Cable Loss (dB) + Antenna Factor (dB/m) - Pre_Amplifier Gain (dB)

Test Site	SIP-AC1	Test Engineer	Stephen Dong
Test Date	2021/02/04	Test Channel	19
Test Mode	BLE-2Mbps		
Note	1. Average measurement was not performed if peak level lower than average limit. 2. Other frequency was 20dB below limit line within 1-18GHz, there is not show in the report.		

Mark	Frequency (MHz)	Reading Level (dB μ V)	Factor (dB)	Measure Level (dB μ V/m)	Limit (dB μ V/m)	Margin (dB)	Detector	Polarization
	8242.0	51.0	-6.6	44.4	74.0	-29.6	Peak	Horizontal
	11081.0	50.8	-5.6	45.3	74.0	-28.7	Peak	Horizontal
	12024.5	50.5	-4.1	46.4	74.0	-27.6	Peak	Horizontal
	8242.0	52.3	-6.6	45.7	74.0	-28.3	Peak	Vertical
	11455.0	50.5	-4.7	45.8	74.0	-28.2	Peak	Vertical
	12577.0	50.1	-3.6	46.5	74.0	-27.5	Peak	Vertical

Note: Measure Level (dB μ V/m) = Reading Level (dB μ V) + Factor (dB)

Factor (dB) = Cable Loss (dB) + Antenna Factor (dB/m) - Pre_Amplifier Gain (dB)

Test Site	SIP-AC1	Test Engineer	Stephen Dong
Test Date	2021/02/04	Test Channel	39
Test Mode	BLE-2Mbps		
Note	1. Average measurement was not performed if peak level lower than average limit. 2. Other frequency was 20dB below limit line within 1-18GHz, there is not show in the report.		

Mark	Frequency (MHz)	Reading Level (dB μ V)	Factor (dB)	Measure Level (dB μ V/m)	Limit (dB μ V/m)	Margin (dB)	Detector	Polarization
	8310.0	49.9	-6.9	43.0	74.0	-31.0	Peak	Horizontal
	11004.5	50.6	-5.7	44.8	74.0	-29.2	Peak	Horizontal
	11650.5	49.9	-4.4	45.5	74.0	-28.5	Peak	Horizontal
	7468.5	50.2	-7.8	42.4	74.0	-31.6	Peak	Vertical
	8327.0	52.0	-6.8	45.2	74.0	-28.8	Peak	Vertical
	11548.5	51.1	-5.2	45.9	74.0	-28.1	Peak	Vertical

Note: Measure Level (dB μ V/m) = Reading Level (dB μ V) + Factor (dB)

Factor (dB) = Cable Loss (dB) + Antenna Factor (dB/m) - Pre_Amplifier Gain (dB)

The Worst Case of Radiated Emission below 1GHz:

Site: SIP-AC1	Time: 2021/02/06
Limit: FCC_Part15.209_RE(3m)	Engineer: Stephen Dong
Probe: SIP-AC1_VULB 9168 _30-1000MHz	Polarity: Horizontal
EUT: WIFI+BT Combo Module	Power: AC 120V/60Hz
Test Mode: Transmit by BLE 1Mbps at Channel 2402MHz	

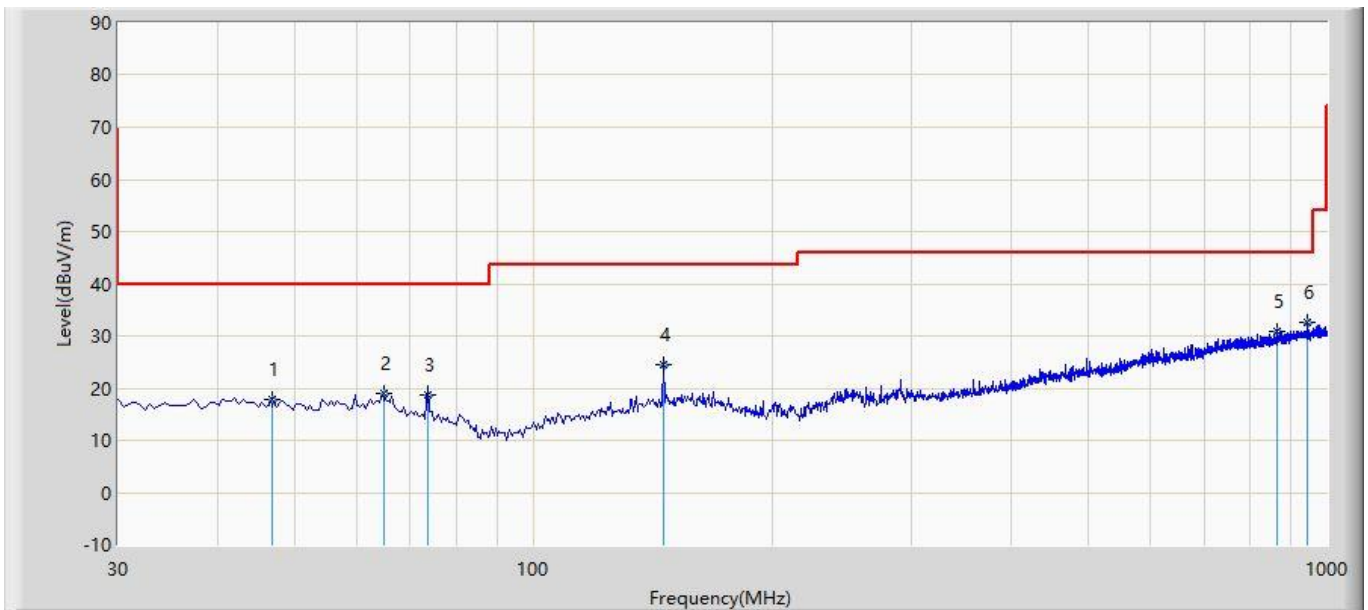

No	Flag	Mark	Frequency (MHz)	Measure Level (dBμV/m)	Reading Level (dBμV)	Margin (dB)	Limit (dBμV/m)	Factor (dB)	Type
1			46.975	17.918	0.141	-22.082	40.000	17.778	QP
2			64.920	19.031	2.641	-20.969	40.000	16.390	QP
3			73.695	18.626	3.964	-21.374	40.000	14.662	QP
4			145.915	24.359	6.440	-19.141	43.500	17.919	QP
5			864.685	30.826	2.600	-15.174	46.000	28.226	QP
6		*	945.195	32.616	3.400	-13.384	46.000	29.216	QP

Note 1: Measure Level (dBμV/m) = Reading Level (dBμV) + Factor (dB)

Factor (dB) = Cable Loss (dB) + Antenna Factor (dB/m)

Note 2: The amplitude of radiated emissions (frequency range from 9kHz ~ 30MHz, 18GHz to 25GHz) is that proximity to ambient noise, which also are attenuated more than 20 dB below the permissible value. Therefore, the data is not presented in the report.

Site: SIP-AC1	Time: 2021/02/06
Limit: FCC_Part15.209_RSE(3m)	Engineer: Stephen Dong
Probe: SIP-AC1_VULB 9168 _30-1000MHz	Polarity: Vertical
EUT: WIFI+BT Combo Module	Power: AC 120V/60Hz
Test Mode: Transmit by BLE 1Mbps at Channel 2402MHz	

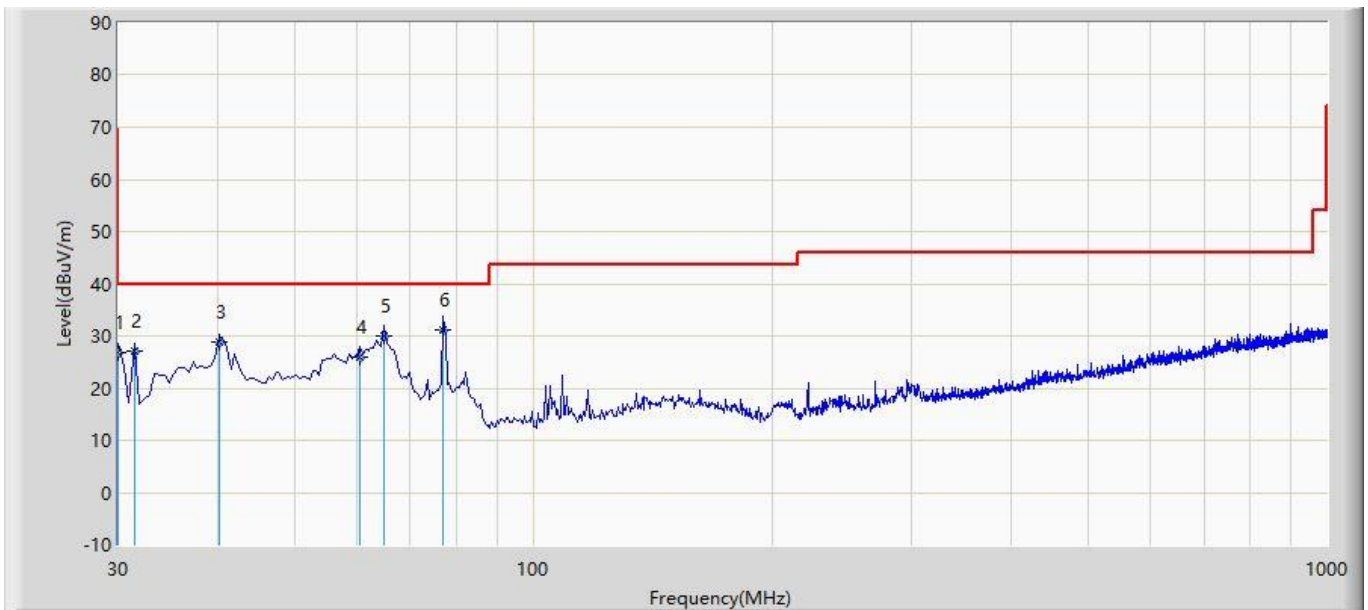

No	Flag	Mark	Frequency (MHz)	Measure Level (dBμV/m)	Reading Level (dBμV)	Margin (dB)	Limit (dBμV/m)	Factor (dB)	Type
1			30.000	26.765	9.999	-13.235	40.000	16.766	QP
2			31.438	27.045	10.340	-12.955	40.000	16.706	QP
3			40.185	28.849	11.364	-11.151	40.000	17.485	QP
4			60.550	25.899	8.990	-14.101	40.000	16.909	QP
5			64.920	30.044	13.654	-9.956	40.000	16.390	QP
6		*	77.045	31.236	17.196	-8.764	40.000	14.040	QP

Note 1: Measure Level (dBμV/m) = Reading Level (dBμV) + Factor (dB)

Factor (dB) = Cable Loss (dB) + Antenna Factor (dB/m)

Note 2: The amplitude of radiated emissions (frequency range from 9kHz ~ 30MHz, 18GHz to 25GHz) is that proximity to ambient noise, which also are attenuated more than 20 dB below the permissible value. Therefore, the data is not presented in the report.

6.7. Radiated Restricted Band Edge Measurement

6.7.1. Test Limit

For 15.205 requirement:

Radiated emissions which fall in the restricted bands, as defined in Section 15.205(a) of FCC part 15, must also comply with the radiated emission limits specified in Section 15.209(a).

Frequency (MHz)	Frequency (MHz)	Frequency (MHz)	Frequency (GHz)
0.090 - 0.110	16.42 - 16.423	399.9 - 410	4.5 - 5.15
¹ 0.495 - 0.505	16.69475 - 16.69525	608 - 614	5.35 - 5.46
2.1735 - 2.1905	16.80425 - 16.80475	960 - 1240	7.25 - 7.75
4.125 - 4.128	25.5 - 25.67	1300 - 1427	8.025 - 8.5
4.17725 - 4.17775	37.5 - 38.25	1435 - 1626.5	9.0 - 9.2
4.20725 - 4.20775	73 - 74.6	1645.5 - 1646.5	9.3 - 9.5
6.215 - 6.218	74.8 - 75.2	1660 - 1710	10.6 - 12.7
6.26775 - 6.26825	108 - 121.94	1718.8 - 1722.2	13.25 - 13.4
6.31175 - 6.31225	123 - 138	2200 - 2300	14.47 - 14.5
8.291 - 8.294	149.9 - 150.05	2310 - 2390	15.35 - 16.2
8.362 - 8.366	156.52475 - 156.52525	2483.5 - 2500	17.7 - 21.4
8.37625 - 8.38675	156.7 - 156.9	2690 - 2900	22.01 - 23.12
8.41425 - 8.41475	162.0125 - 167.17	3260 - 3267	23.6 - 24.0
12.29 - 12.293	167.72 - 173.2	3332 - 3339	31.2 - 31.8
12.51975 - 12.52025	240 - 285	3345.8 - 3358	36.43 - 36.5
12.57675 - 12.57725	322 - 335.4	3600 - 4400	(²)
13.36 - 13.41	--	--	--

All out of band emissions appearing in a restricted band as specified in Section 15.205 of the Title 47CFR must not exceed the limits shown in Table per Section 15.209.

FCC Part 15 Subpart C Paragraph 15.209 Limits		
Frequency [MHz]	Field Strength [uV/m]	Measured Distance [Meters]
0.009 - 0.490	2400/F (kHz)	300
0.490 - 1.705	24000/F (kHz)	30
1.705 - 30	30	30
30 - 88	100	3
88 - 216	150	3
216 - 960	200	3
Above 960	500	3

For RSS-Gen Section 8.10 Requirement

Radiated emissions which fall in the restricted bands, as defined in Section 8.10 of RSS-Gen, must also comply with the radiated emission limits specified in Section 8.9.

Frequency (MHz)	Frequency (MHz)	Frequency (GHz)
0.090 - 0.110	149.9 - 150.05	9.0 - 9.2
0.495 - 0.505	156.52475 - 156.525225	9.3 - 9.5
2.1735 - 2.1905	156.7 - 156.9	10.6 - 12.7
3.020 - 3.026	162.0125 - 167.17	13.25 - 13.4
4.125 - 4.128	167.72 - 173.2	14.47 - 14.5
4.17725 - 4.17775	240 - 285	15.35 - 16.2
4.20725 - 4.20775	322 - 335.4	17.7 - 21.4
5.677 - 5.683	399.9 - 410	22.01 - 23.12
6.215 - 6.218	608 - 614	23.6 - 24.0
6.26775 - 6.26825	960 - 1427	31.2 - 31.8
6.31175 - 6.31225	1435 - 1626.5	36.43 - 36.5
8.291 - 8.294	1645.5 - 1646.5	Above 38.6
8.362 - 8.366	1660 - 1710	--
8.37625 - 8.38675	1718.8 - 1722.2	
8.41425 - 8.41475	2200 - 2300	
12.29 - 12.293	2310 - 2390	
12.51975 - 12.52025	2483.5 - 2500	
12.57675 - 12.57725	2655 - 2900	
13.36 - 13.41	3260 - 3267	
16.42 - 16.423	3332 - 3339	
16.69475 - 16.69525	3345.8 - 3358	
16.80425 - 16.80475	3500 - 4400	
25.5 - 25.67	4500 - 5150	
37.5 - 38.25	5350 - 5460	
73 - 74.6	7250 - 7750	
74.8 - 75.2	8025 - 8500	
108 - 138	--	

All out of band emissions appearing in a restricted band as specified in Section 8.10 of the RSS-Gen must not exceed the limits shown in Table per Section 8.9.

RSS-Gen Section 8.9			
Frequency [MHz]	Magnetic field strength (H-Field) [uA/m]	Field Strength [uV/m]	Measured Distance [Meters]
0.009 - 0.490	6.37/F(F in kHz)	--	300
0.490 - 1.705	63.7/F(F in kHz)	--	30
1.705 - 30	0.08	--	30
30 - 88	--	100	3
88 - 216	--	150	3
216 - 960	--	200	3
Above 960	--	500	3

6.7.2. Test Procedure Used

ANSI C63.10 Section 6.3 (General Requirements)

ANSI C63.10 Section 6.6 (Standard test method above 1GHz)

6.7.3. Test Setting

Peak Field Strength Measurements

1. Analyzer center frequency was set to the frequency of the radiated spurious emission of interest
2. RBW = 1MHz
3. VBW = 3MHz
4. Detector = peak
5. Sweep time = auto couple
6. Trace mode = max hold
7. Trace was allowed to stabilize

Average Measurements above 1GHz (Method VB)

1. Analyzer center frequency was set to the frequency of the radiated spurious emission of interest
2. RBW = 1MHz
3. VBW; If the EUT is configured to transmit with duty cycle $\geq 98\%$, set VBW = 10 Hz.

If the EUT duty cycle is $< 98\%$, set $VBW \geq 1/T$. T is the minimum transmission duration.

4. Detector = Peak
5. Sweep time = auto
6. Trace mode = max hold
7. Trace was allowed to stabilize

6.7.4. Test Setup

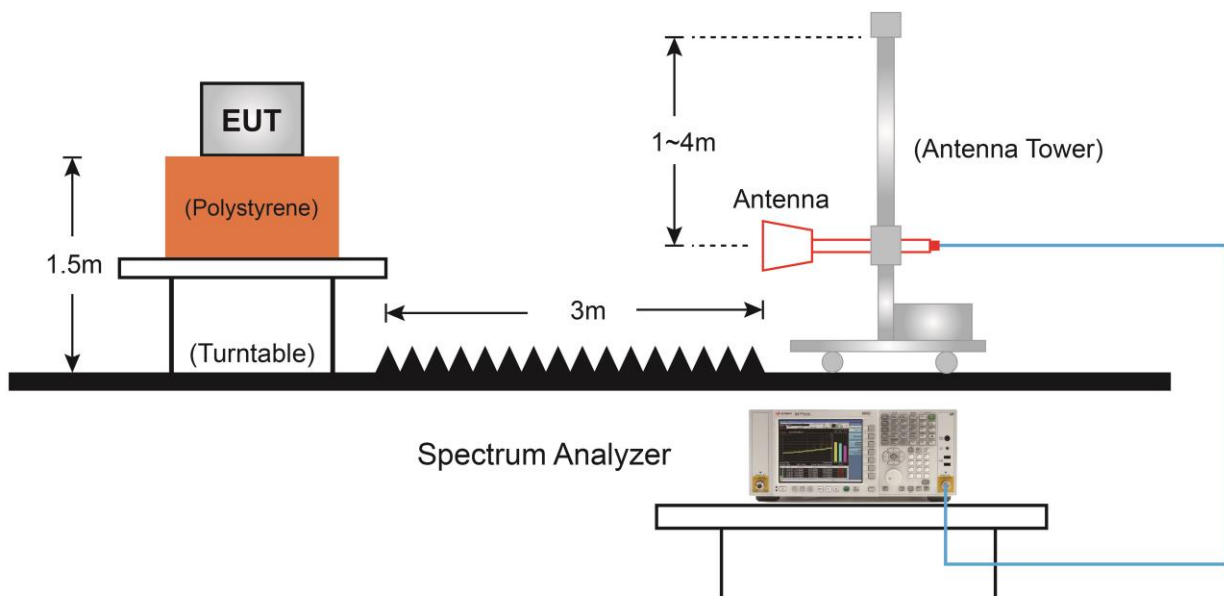

6.7.5. Test Result

Site: SIP-AC1	Time: 2021/02/04 - 10:25
Limit: FCC_Part15.209_RE(3m)	Engineer: Stephen Dong
Probe: SIP-AC1_HF907_102862_1-18GHz	Polarity: Horizontal
EUT: WIFI+BT Combo Module	Power: AC 120V/60Hz
Test Mode: Transmit by BLE 1Mbps at Channel 2402MHz	

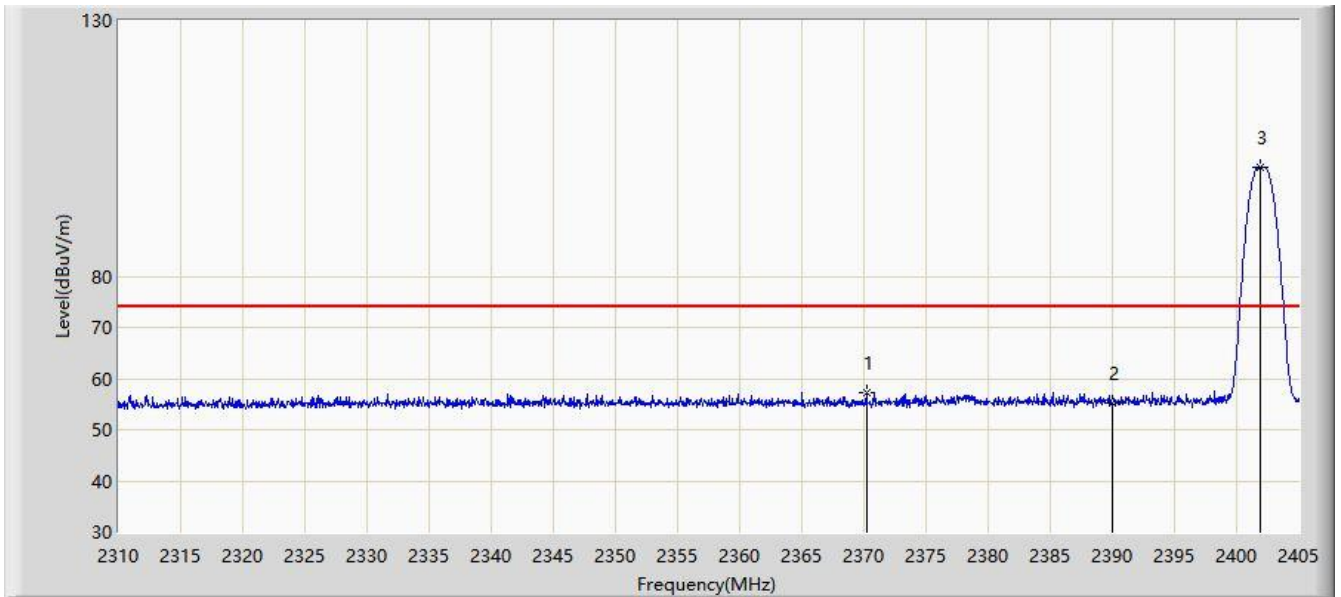

No	Flag	Mark	Frequency (MHz)	Measure Level (dBμV/m)	Reading Level (dBμV)	Margin (dB)	Limit (dBμV/m)	Factor (dB)	Type
1			2370.183	57.237	26.520	-16.763	74.000	30.716	PK
2			2390.000	55.103	24.277	-18.897	74.000	30.826	PK
3		*	2401.913	101.281	70.389	N/A	N/A	30.892	PK

Note: Measure Level (dBμV/m) = Reading Level (dBμV) + Factor (dB)

Factor (dB) = Cable Loss (dB) + Antenna Factor (dB/m)

Site: SIP-AC1	Time: 2021/02/04 - 10:31
Limit: FCC_Part15.209_RE(3m)	Engineer: Stephen Dong
Probe: SIP-AC1_HF907_102862_1-18GHz	Polarity: Horizontal
EUT: WIFI+BT Combo Module	Power: AC 120V/60Hz
Test Mode: Transmit by BLE 1Mbps at Channel 2402MHz	

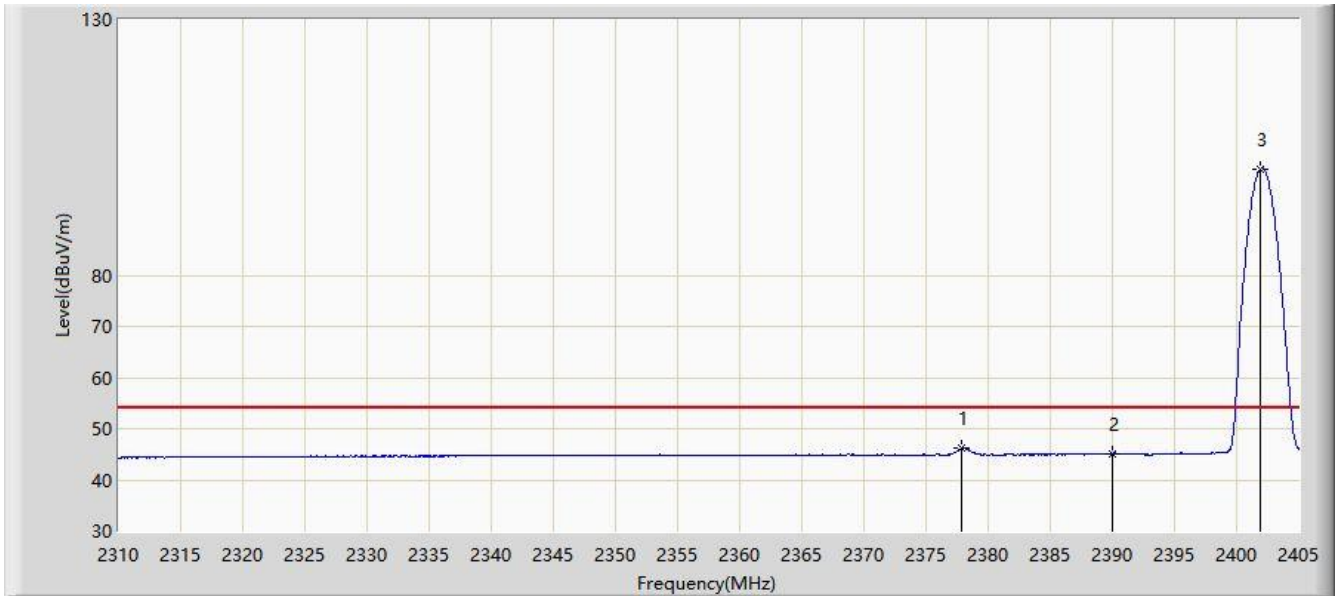

No	Flag	Mark	Frequency (MHz)	Measure Level (dBuV/m)	Reading Level (dBuV)	Margin (dB)	Limit (dBuV/m)	Factor (dB)	Type
1			2377.830	46.155	15.410	-7.845	54.000	30.745	AV
2			2390.000	45.100	14.274	-8.900	54.000	30.826	AV
3		*	2401.913	100.756	69.864	N/A	N/A	30.892	AV

Note: Measure Level (dBuV/m) = Reading Level (dBuV) + Factor (dB)

Factor (dB) = Cable Loss (dB) + Antenna Factor (dB/m)

Site: SIP-AC1	Time: 2021/02/04 - 10:34
Limit: FCC_Part15.209_RE(3m)	Engineer: Stephen Dong
Probe: SIP-AC1_HF907_102862_1-18GHz	Polarity: Vertical
EUT: WIFI+BT Combo Module	Power: AC 120V/60Hz
Test Mode: Transmit by BLE 1Mbps at Channel 2402MHz	

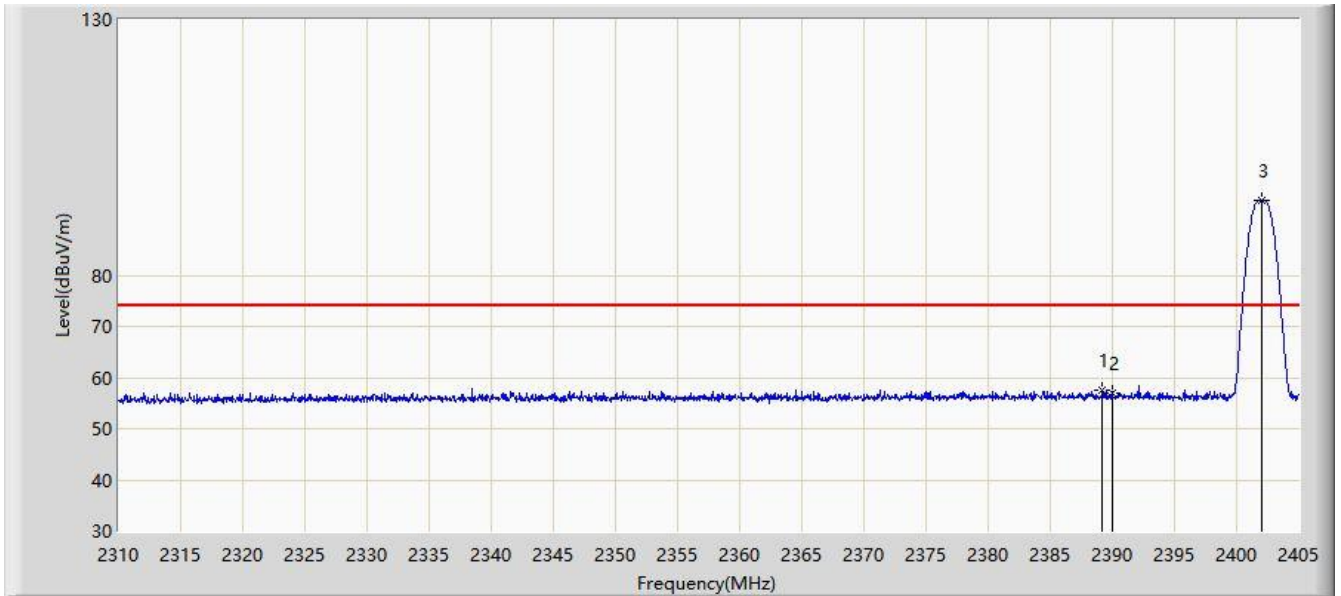

No	Flag	Mark	Frequency (MHz)	Measure Level (dBuV/m)	Reading Level (dBuV)	Margin (dB)	Limit (dBuV/m)	Factor (dB)	Type
1			2389.183	57.542	26.721	-16.458	74.000	30.821	PK
2			2390.000	56.891	26.065	-17.109	74.000	30.826	PK
3		*	2402.008	94.645	63.752	N/A	N/A	30.892	PK

Note: Measure Level (dBuV/m) = Reading Level (dBuV) + Factor (dB)

Factor (dB) = Cable Loss (dB) + Antenna Factor (dB/m)

Site: SIP-AC1	Time: 2021/02/04 - 10:38
Limit: FCC_Part15.209_RE(3m)	Engineer: Stephen Dong
Probe: SIP-AC1_HF907_102862_1-18GHz	Polarity: Vertical
EUT: WIFI+BT Combo Module	Power: AC 120V/60Hz
Test Mode: Transmit by BLE 1Mbps at Channel 2402MHz	

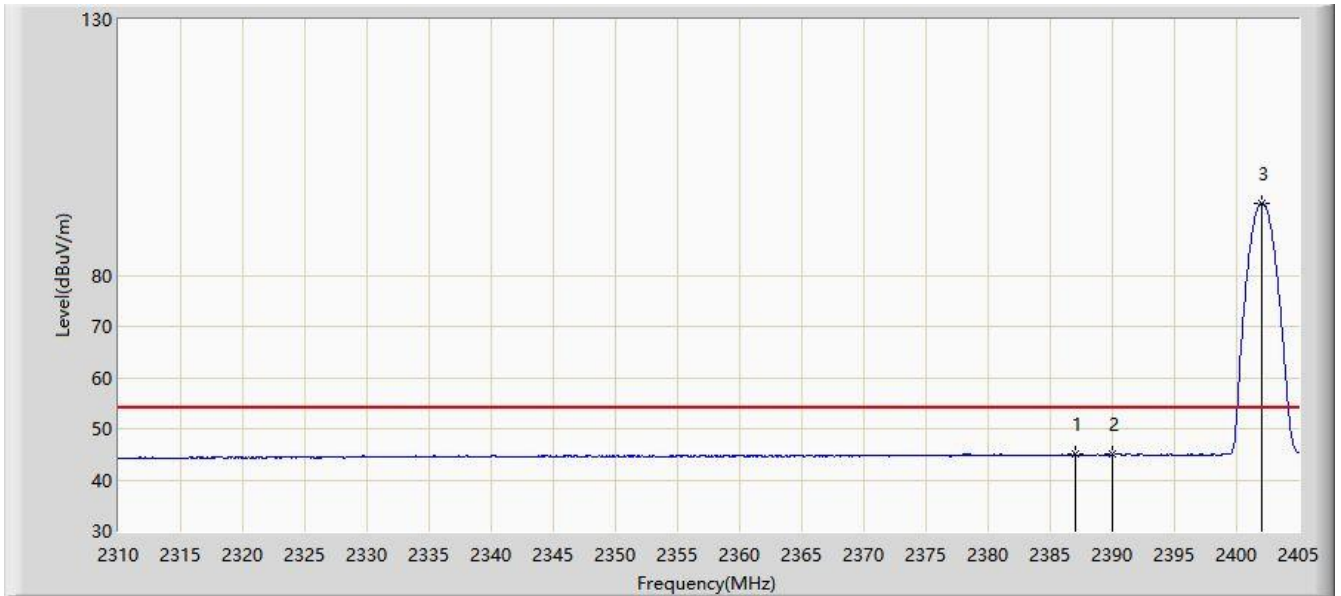

No	Flag	Mark	Frequency (MHz)	Measure Level (dBμV/m)	Reading Level (dBμV)	Margin (dB)	Limit (dBμV/m)	Factor (dB)	Type
1			2386.998	45.005	14.199	-8.995	54.000	30.806	AV
2			2390.000	44.937	14.111	-9.063	54.000	30.826	AV
3		*	2402.008	94.149	63.256	N/A	N/A	30.892	AV

Note: Measure Level (dBμV/m) = Reading Level (dBμV) + Factor (dB)

Factor (dB) = Cable Loss (dB) + Antenna Factor (dB/m)

Site: SIP-AC1	Time: 2021/02/04 - 10:38
Limit: FCC_Part15.209_RE(3m)	Engineer: Stephen Dong
Probe: SIP-AC1_HF907_102862_1-18GHz	Polarity: Horizontal
EUT: WIFI+BT Combo Module	Power: AC 120V/60Hz
Test Mode: Transmit by BLE 1Mbps at Channel 2480MHz	

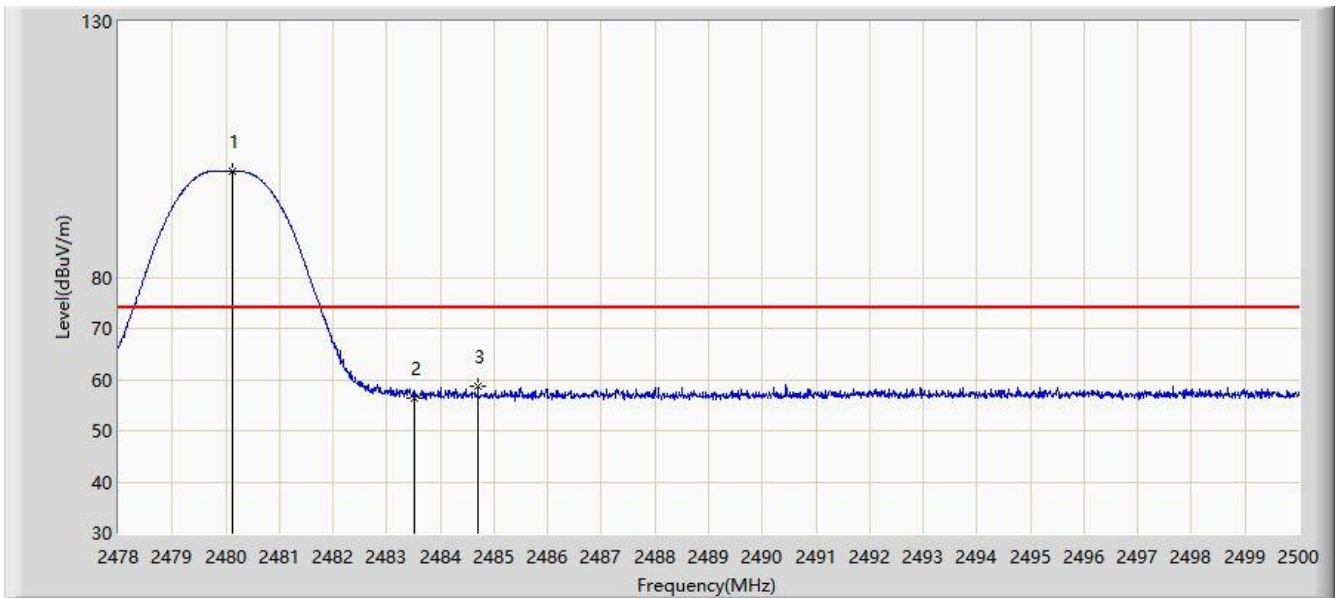

No	Flag	Mark	Frequency (MHz)	Measure Level (dBuV/m)	Reading Level (dBuV)	Margin (dB)	Limit (dBuV/m)	Factor (dB)	Type
1		*	2480.112	100.685	69.426	N/A	N/A	31.259	PK
2			2483.500	56.486	25.213	-17.514	74.000	31.273	PK
3			2484.699	58.627	27.349	-15.373	74.000	31.278	PK

Note: Measure Level (dBuV/m) = Reading Level (dBuV) + Factor (dB)

Factor (dB) = Cable Loss (dB) + Antenna Factor (dB/m)

Site: SIP-AC1	Time: 2021/02/04 - 10:41
Limit: FCC_Part15.209_RE(3m)	Engineer: Stephen Dong
Probe: SIP-AC1_HF907_102862_1-18GHz	Polarity: Horizontal
EUT: WIFI+BT Combo Module	Power: AC 120V/60Hz
Test Mode: Transmit by BLE 1Mbps at Channel 2480MHz	

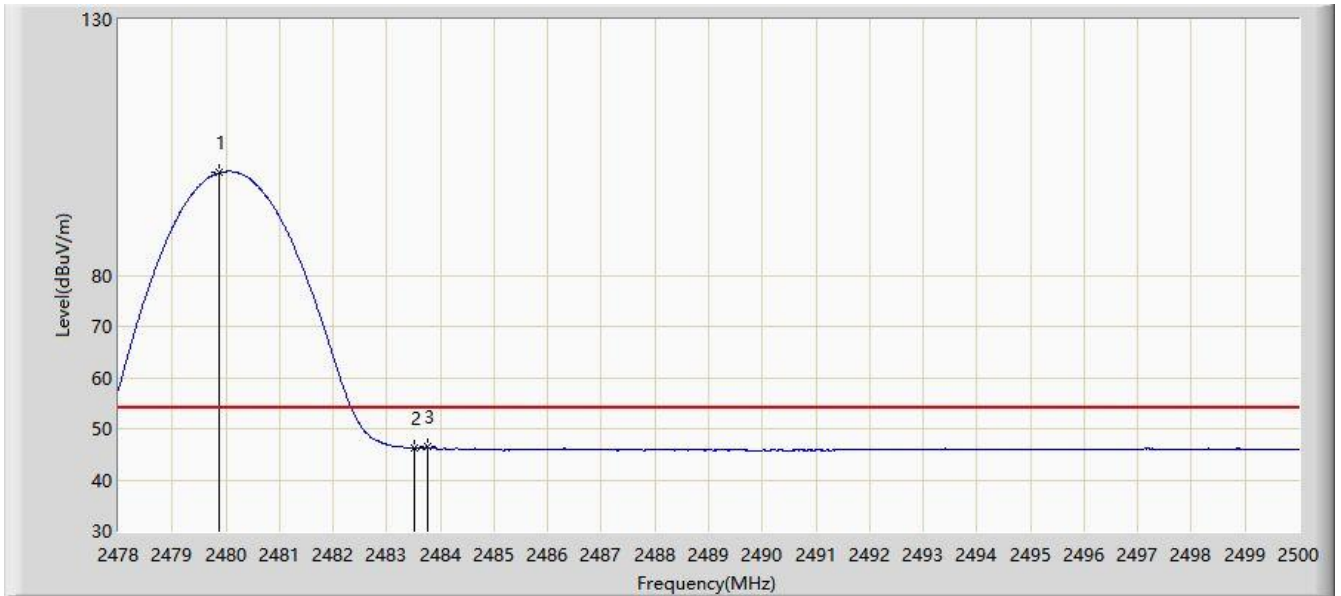

No	Flag	Mark	Frequency (MHz)	Measure Level (dBuV/m)	Reading Level (dBuV)	Margin (dB)	Limit (dBuV/m)	Factor (dB)	Type
1		*	2479.881	100.060	68.801	N/A	N/A	31.258	AV
2			2483.500	46.169	14.896	-7.831	54.000	31.273	AV
3			2483.764	46.391	15.117	-7.609	54.000	31.274	AV

Note: Measure Level (dBuV/m) = Reading Level (dBuV) + Factor (dB)

Factor (dB) = Cable Loss (dB) + Antenna Factor (dB/m)

Site: SIP-AC1	Time: 2021/02/04 - 10:41
Limit: FCC_Part15.209_RE(3m)	Engineer: Stephen Dong
Probe: SIP-AC1_HF907_102862_1-18GHz	Polarity: Vertical
EUT: WIFI+BT Combo Module	Power: AC 120V/60Hz
Test Mode: Transmit by BLE 1Mbps at Channel 2480MHz	

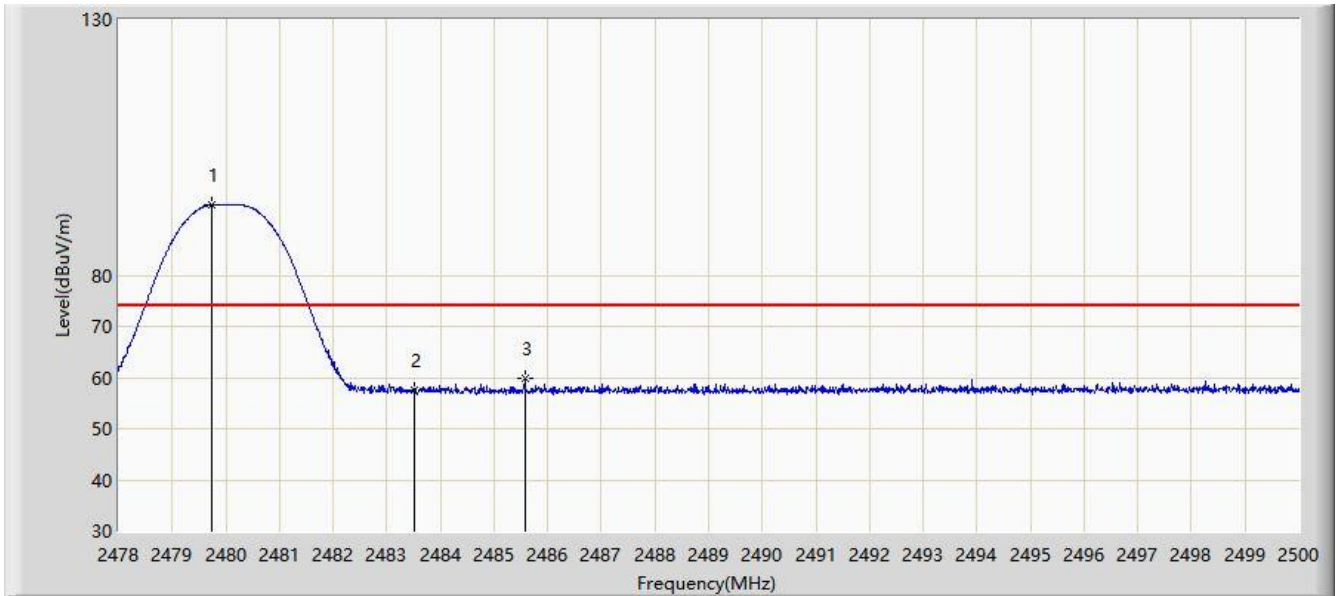

No	Flag	Mark	Frequency (MHz)	Measure Level (dBuV/m)	Reading Level (dBuV)	Margin (dB)	Limit (dBuV/m)	Factor (dB)	Type
1		*	2479.749	93.838	62.580	N/A	N/A	31.258	PK
2			2483.500	57.594	26.321	-16.406	74.000	31.273	PK
3			2485.568	59.752	28.471	-14.248	74.000	31.281	PK

Note: Measure Level (dBuV/m) = Reading Level (dBuV) + Factor (dB)

Factor (dB) = Cable Loss (dB) + Antenna Factor (dB/m)

Site: SIP-AC1	Time: 2021/02/04 - 10:49
Limit: FCC_Part15.209_RE(3m)	Engineer: Stephen Dong
Probe: SIP-AC1_HF907_102862_1-18GHz	Polarity: Vertical
EUT: WIFI+BT Combo Module	Power: AC 120V/60Hz
Test Mode: Transmit by BLE 1Mbps at Channel 2480MHz	

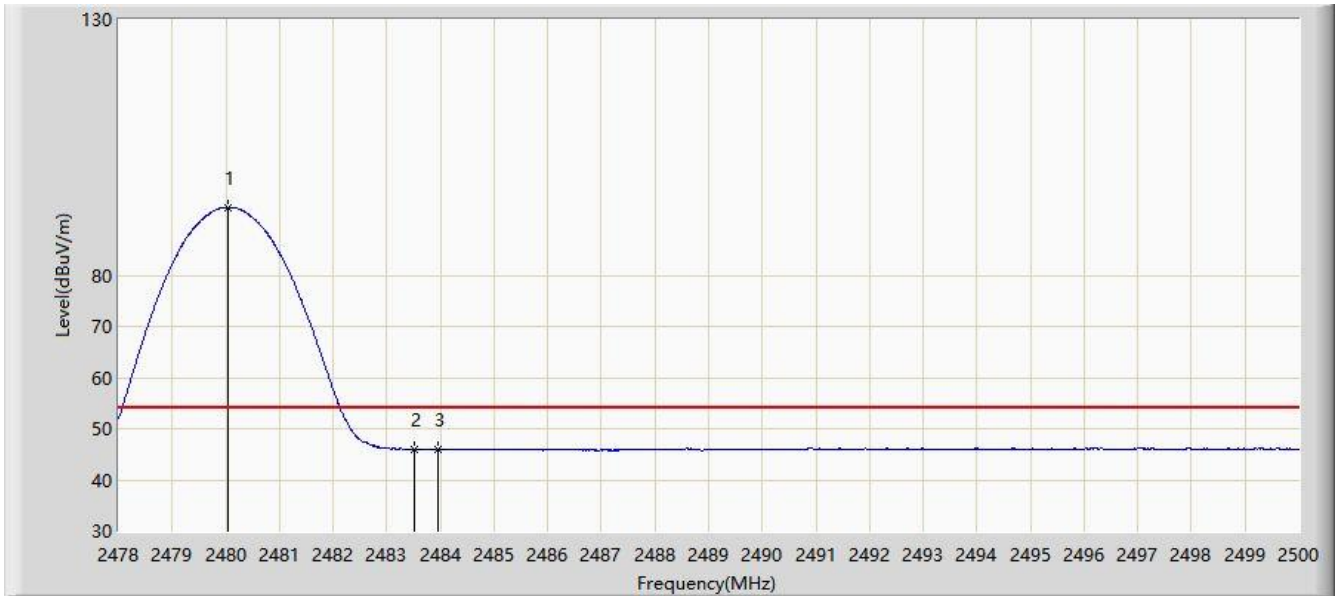

No	Flag	Mark	Frequency (MHz)	Measure Level (dBμV/m)	Reading Level (dBμV)	Margin (dB)	Limit (dBμV/m)	Factor (dB)	Type
1		*	2480.046	93.296	62.037	N/A	N/A	31.259	AV
2			2483.500	45.844	14.571	-8.156	54.000	31.273	AV
3			2483.962	45.976	14.701	-8.024	54.000	31.274	AV

Note: Measure Level (dBμV/m) = Reading Level (dBμV) + Factor (dB)

Factor (dB) = Cable Loss (dB) + Antenna Factor (dB/m)

Site: SIP-AC1	Time: 2021/02/04 - 10:50
Limit: FCC_Part15.209_RE(3m)	Engineer: Stephen Dong
Probe: SIP-AC1_HF907_102862_1-18GHz	Polarity: Horizontal
EUT: WIFI+BT Combo Module	Power: AC 120V/60Hz
Test Mode: Transmit by BLE 2Mbps at Channel 2402MHz	

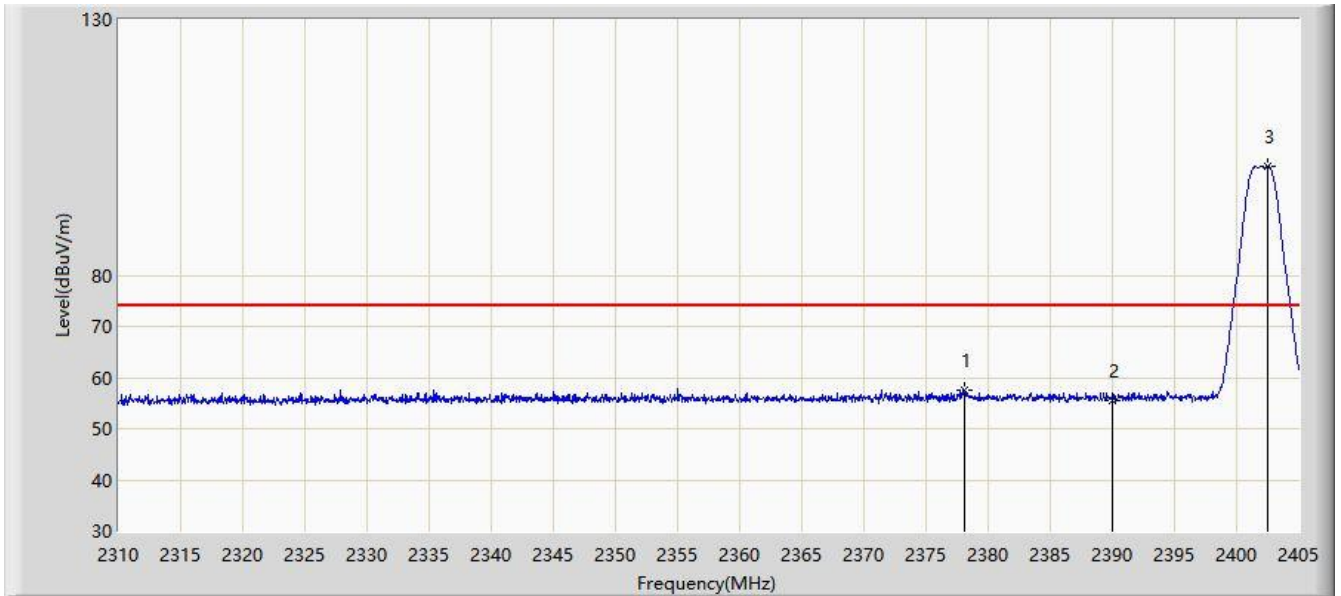

No	Flag	Mark	Frequency (MHz)	Measure Level (dBuV/m)	Reading Level (dBuV)	Margin (dB)	Limit (dBuV/m)	Factor (dB)	Type
1			2378.115	57.639	26.893	-16.361	74.000	30.747	PK
2			2390.000	55.624	24.798	-18.376	74.000	30.826	PK
3		*	2402.530	101.285	70.390	N/A	N/A	30.895	PK

Note: Measure Level (dBuV/m) = Reading Level (dBuV) + Factor (dB)

Factor (dB) = Cable Loss (dB) + Antenna Factor (dB/m)

Site: SIP-AC1	Time: 2021/02/04 - 10:53
Limit: FCC_Part15.209_RE(3m)	Engineer: Stephen Dong
Probe: SIP-AC1_HF907_102862_1-18GHz	Polarity: Horizontal
EUT: WIFI+BT Combo Module	Power: AC 120V/60Hz
Test Mode: Transmit by BLE 2Mbps at Channel 2402MHz	

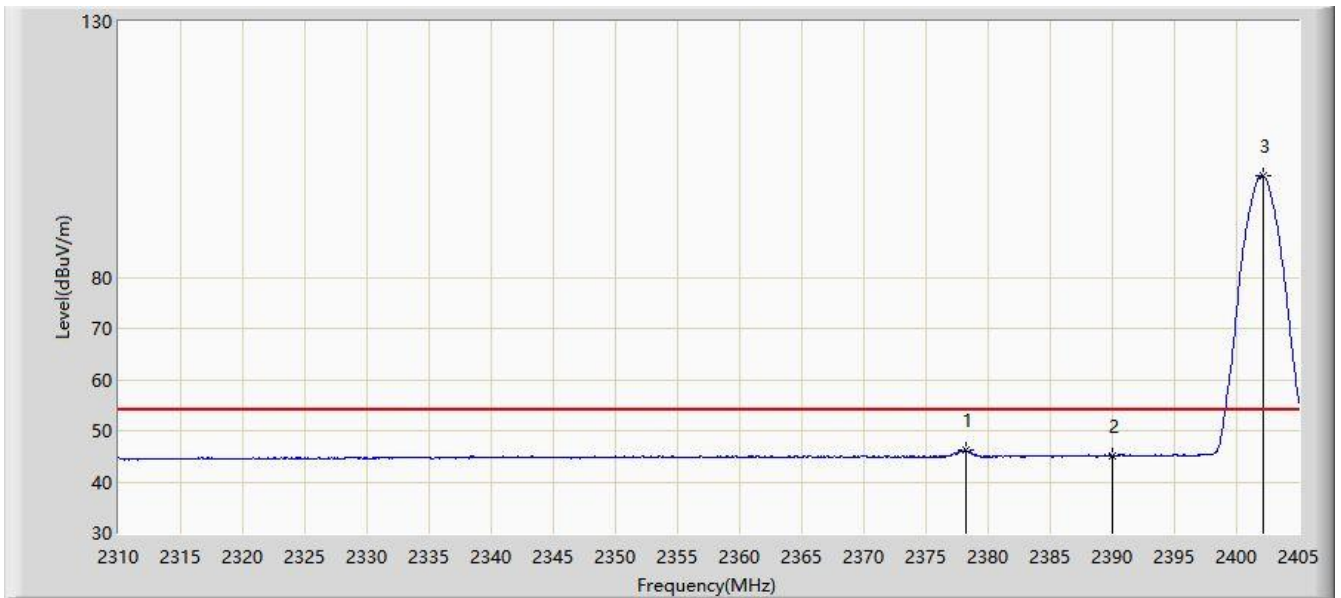

No	Flag	Mark	Frequency (MHz)	Measure Level (dBuV/m)	Reading Level (dBuV)	Margin (dB)	Limit (dBuV/m)	Factor (dB)	Type
1			2378.258	46.173	15.426	-7.827	54.000	30.747	AV
2			2390.000	45.113	14.287	-8.887	54.000	30.826	AV
3		*	2402.103	99.892	68.999	N/A	N/A	30.893	AV

Note: Measure Level (dBuV/m) = Reading Level (dBuV) + Factor (dB)

Factor (dB) = Cable Loss (dB) + Antenna Factor (dB/m)

Site: SIP-AC1	Time: 2021/02/04 - 10:55
Limit: FCC_Part15.209_RE(3m)	Engineer: Stephen Dong
Probe: SIP-AC1_HF907_102862_1-18GHz	Polarity: Vertical
EUT: WIFI+BT Combo Module	Power: AC 120V/60Hz
Test Mode: Transmit by BLE 2Mbps at Channel 2402MHz	

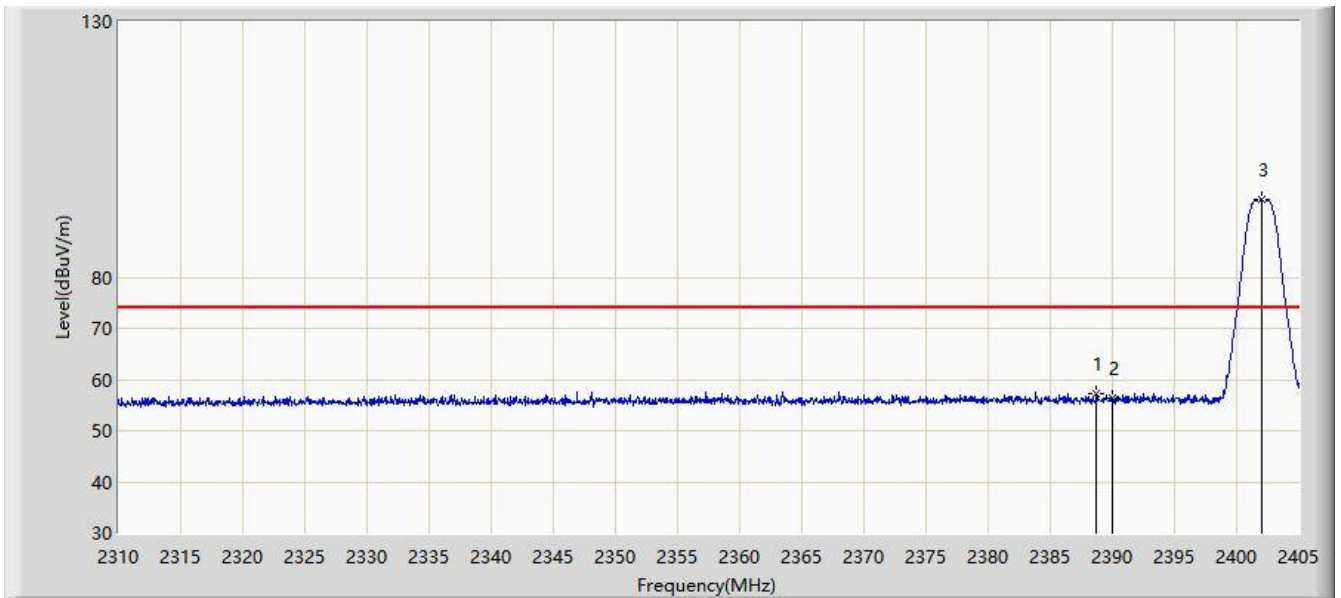

No	Flag	Mark	Frequency (MHz)	Measure Level (dBuV/m)	Reading Level (dBuV)	Margin (dB)	Limit (dBuV/m)	Factor (dB)	Type
1			2388.708	57.246	26.428	-16.754	74.000	30.818	PK
2			2390.000	56.325	25.499	-17.675	74.000	30.826	PK
3		*	2402.008	95.089	64.196	N/A	N/A	30.892	PK

Note: Measure Level (dBuV/m) = Reading Level (dBuV) + Factor (dB)

Factor (dB) = Cable Loss (dB) + Antenna Factor (dB/m)

Site: SIP-AC1	Time: 2021/02/04 - 10:57
Limit: FCC_Part15.209_RE(3m)	Engineer: Stephen Dong
Probe: SIP-AC1_HF907_102862_1-18GHz	Polarity: Vertical
EUT: WIFI+BT Combo Module	Power: AC 120V/60Hz
Test Mode: Transmit by BLE 2Mbps at Channel 2402MHz	

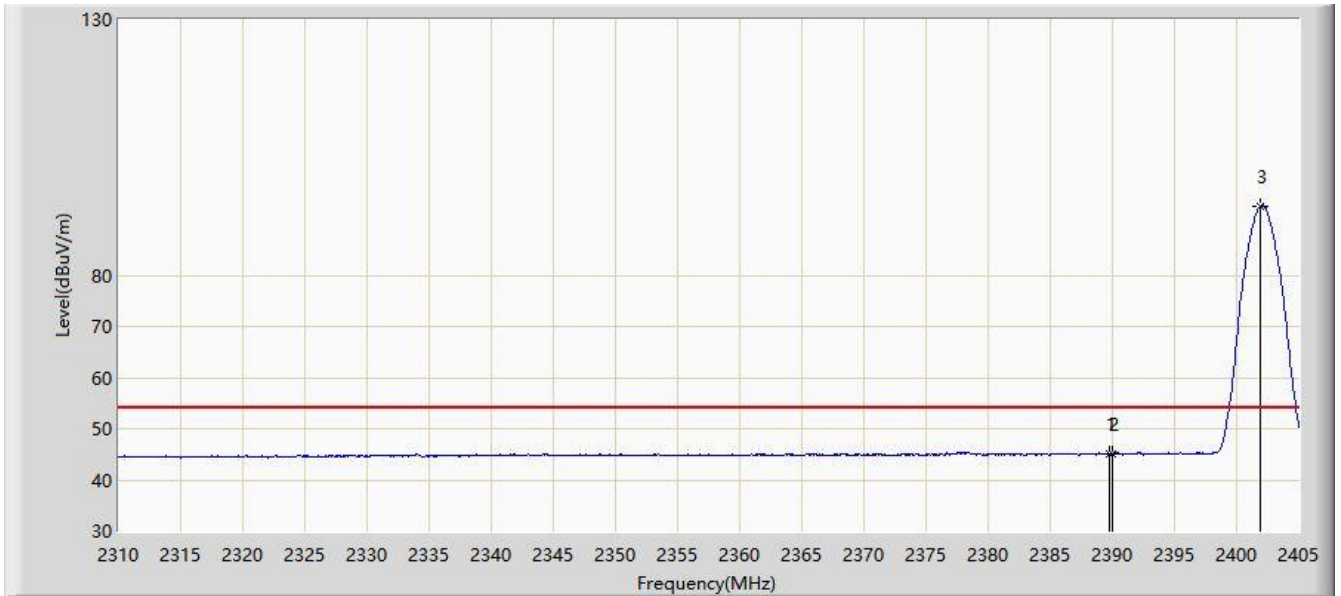

No	Flag	Mark	Frequency (MHz)	Measure Level (dBuV/m)	Reading Level (dBuV)	Margin (dB)	Limit (dBuV/m)	Factor (dB)	Type
1			2389.752	45.215	14.390	-8.785	54.000	30.825	AV
2			2390.000	44.977	14.151	-9.023	54.000	30.826	AV
3		*	2401.913	93.516	62.624	N/A	N/A	30.892	AV

Note: Measure Level (dBuV/m) = Reading Level (dBuV) + Factor (dB)

Factor (dB) = Cable Loss (dB) + Antenna Factor (dB/m)

Site: SIP-AC1	Time: 2021/02/04 - 10:58
Limit: FCC_Part15.209_RE(3m)	Engineer: Stephen Dong
Probe: SIP-AC1_HF907_102862_1-18GHz	Polarity: Horizontal
EUT: WIFI+BT Combo Module	Power: AC 120V/60Hz
Test Mode: Transmit by BLE 2Mbps at Channel 2480MHz	

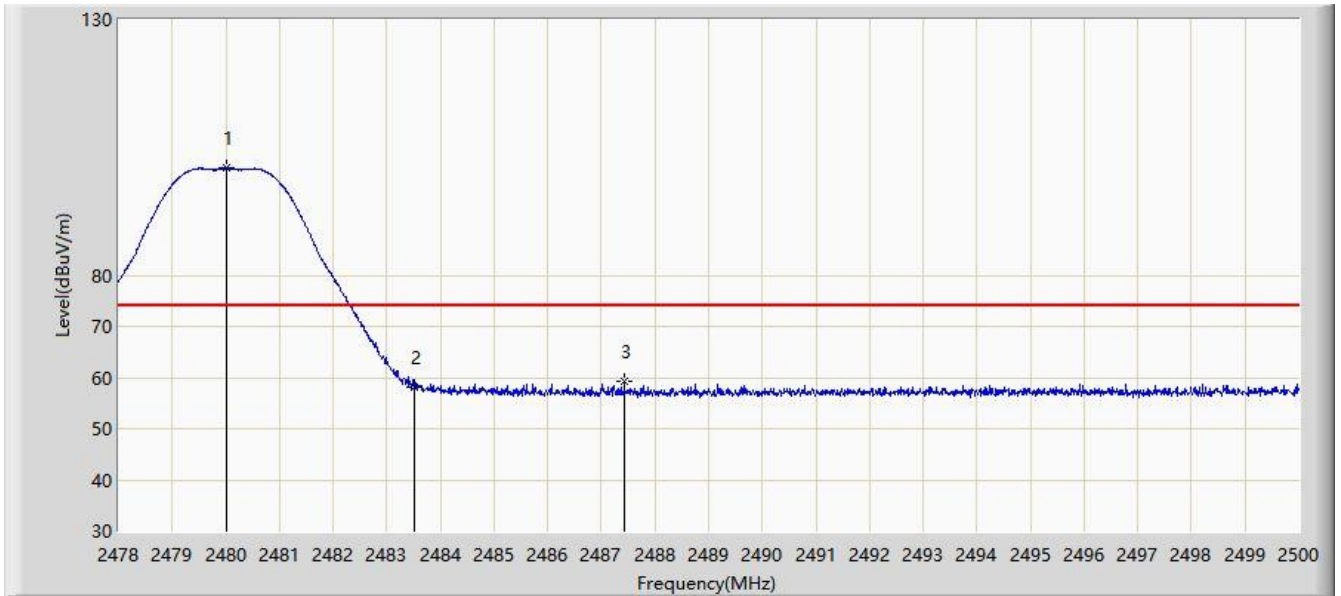

No	Flag	Mark	Frequency (MHz)	Measure Level (dBμV/m)	Reading Level (dBμV)	Margin (dB)	Limit (dBμV/m)	Factor (dB)	Type
1		*	2480.002	100.969	69.710	N/A	N/A	31.259	PK
2			2483.500	58.114	26.841	-15.886	74.000	31.273	PK
3			2487.427	59.140	27.851	-14.860	74.000	31.288	PK

Note: Measure Level (dBμV/m) = Reading Level (dBμV) + Factor (dB)

Factor (dB) = Cable Loss (dB) + Antenna Factor (dB/m)

Site: SIP-AC1	Time: 2021/02/04 - 11:00
Limit: FCC_Part15.209_RE(3m)	Engineer: Stephen Dong
Probe: SIP-AC1_HF907_102862_1-18GHz	Polarity: Horizontal
EUT: WIFI+BT Combo Module	Power: AC 120V/60Hz
Test Mode: Transmit by BLE 2Mbps at Channel 2480MHz	

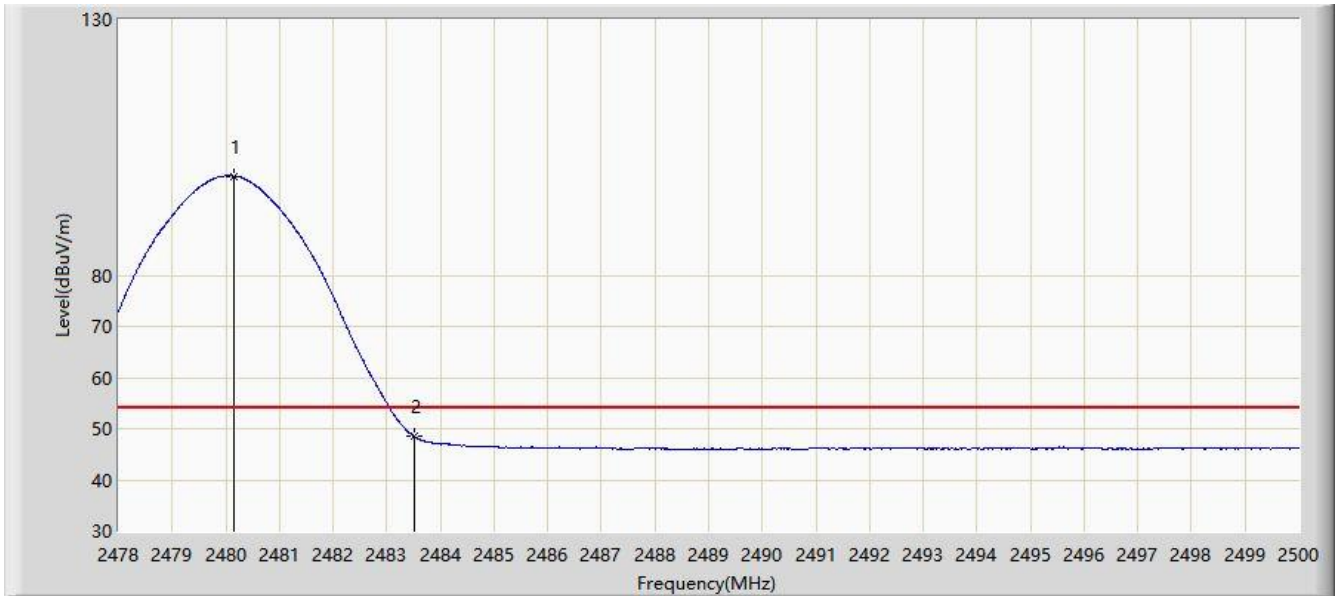

No	Flag	Mark	Frequency (MHz)	Measure Level (dBuV/m)	Reading Level (dBuV)	Margin (dB)	Limit (dBuV/m)	Factor (dB)	Type
1		*	2480.145	99.412	68.152	N/A	N/A	31.259	AV
2			2483.500	48.443	17.170	-5.557	54.000	31.273	AV

Note: Measure Level (dBuV/m) = Reading Level (dBuV) + Factor (dB)

Factor (dB) = Cable Loss (dB) + Antenna Factor (dB/m)

Site: SIP-AC1	Time: 2021/02/04 - 11:01
Limit: FCC_Part15.209_RE(3m)	Engineer: Stephen Dong
Probe: SIP-AC1_HF907_102862_1-18GHz	Polarity: Vertical
EUT: WIFI+BT Combo Module	Power: AC 120V/60Hz
Test Mode: Transmit by BLE 2Mbps at Channel 2480MHz	

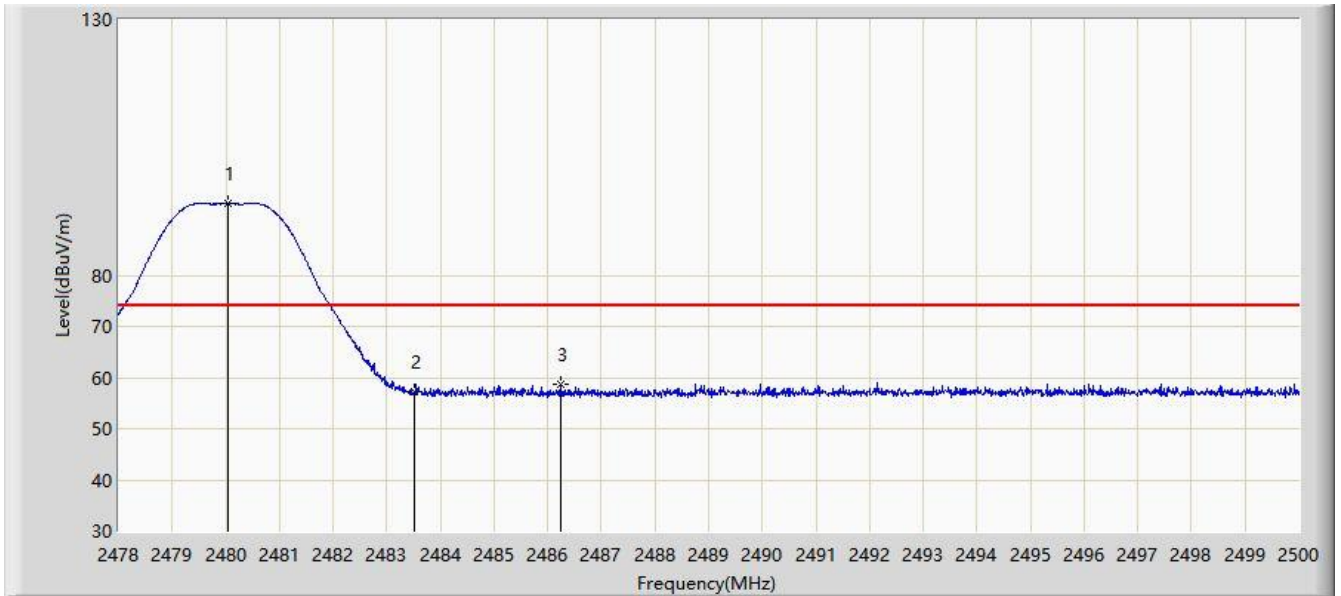

No	Flag	Mark	Frequency (MHz)	Measure Level (dBμV/m)	Reading Level (dBμV)	Margin (dB)	Limit (dBμV/m)	Factor (dB)	Type
1		*	2480.046	94.191	62.932	N/A	N/A	31.259	PK
2			2483.500	57.292	26.019	-16.708	74.000	31.273	PK
3			2486.239	58.553	27.269	-15.447	74.000	31.284	PK

Note: Measure Level (dBμV/m) = Reading Level (dBμV) + Factor (dB)

Factor (dB) = Cable Loss (dB) + Antenna Factor (dB/m)

Site: SIP-AC1	Time: 2021/02/04 - 11:03
Limit: FCC_Part15.209_RE(3m)	Engineer: Stephen Dong
Probe: SIP-AC1_HF907_102862_1-18GHz	Polarity: Vertical
EUT: WIFI+BT Combo Module	Power: AC 120V/60Hz
Test Mode: Transmit by BLE 2Mbps at Channel 2480MHz	



No	Flag	Mark	Frequency (MHz)	Measure Level (dBuV/m)	Reading Level (dBuV)	Margin (dB)	Limit (dBuV/m)	Factor (dB)	Type
1		*	2480.046	92.759	61.500	N/A	N/A	31.259	AV
2			2483.500	46.682	15.409	-7.318	54.000	31.273	AV
3			2483.676	46.710	15.436	-7.290	54.000	31.273	AV

Note: Measure Level (dBuV/m) = Reading Level (dBuV) + Factor (dB)

Factor (dB) = Cable Loss (dB) + Antenna Factor (dB/m)

6.8. AC Conducted Emissions Measurement

6.8.1. Test Limit

FCC Part 15 Subpart C Paragraph 15.207 Limits		
Frequency (MHz)	QP (dB μ V)	AV (dB μ V)
0.15 - 0.50	66 - 56	56 - 46
0.50 - 5.0	56	46
5.0 - 30	60	50

Note 1: The lower limit shall apply at the transition frequencies.

Note 2: The limit decreases linearly with the logarithm of the frequency in the range 0.15MHz to 0.5MHz.

6.8.2. Test Setup

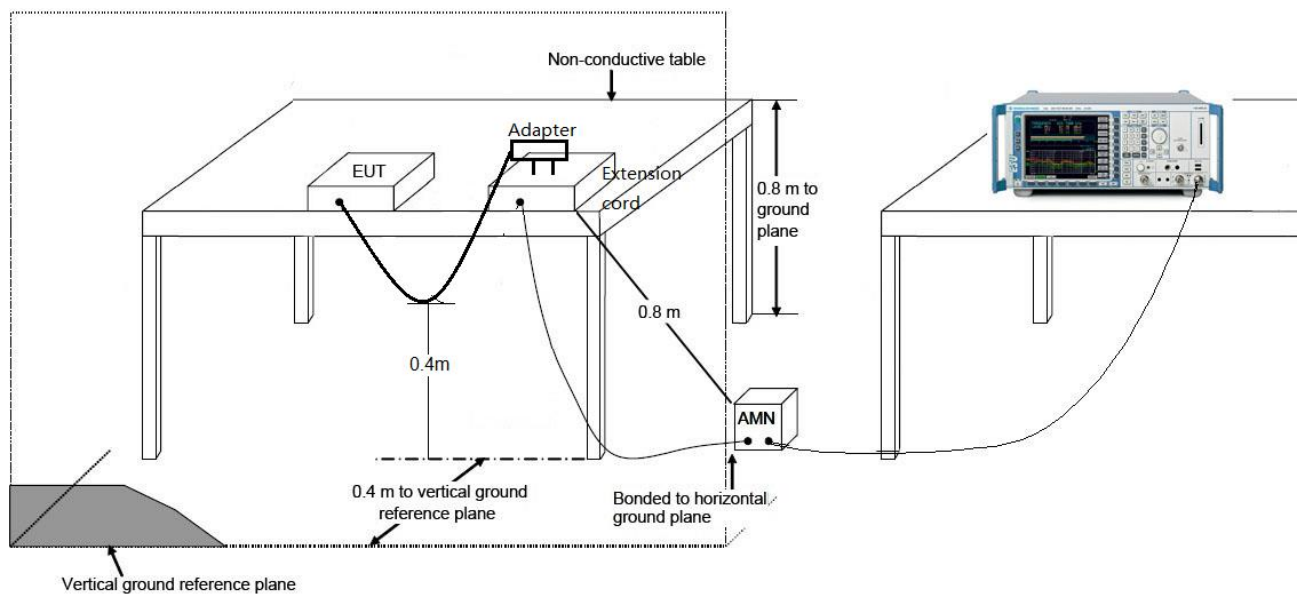

6.8.3. Test Result

Site: WZ-SR2	Time: 2021/02/01
Limit: FCC_Part15.207_CE_AC Power	Engineer: Hyde Yu
Probe: ENV216_101683_Filter Off_Without Adapter	Polarity: Line
EUT: WIFI+BT Combo Module	Power: AC 120V/60Hz
Test Mode: Transmit by BLE 2Mbps at Channel 2402MHz	

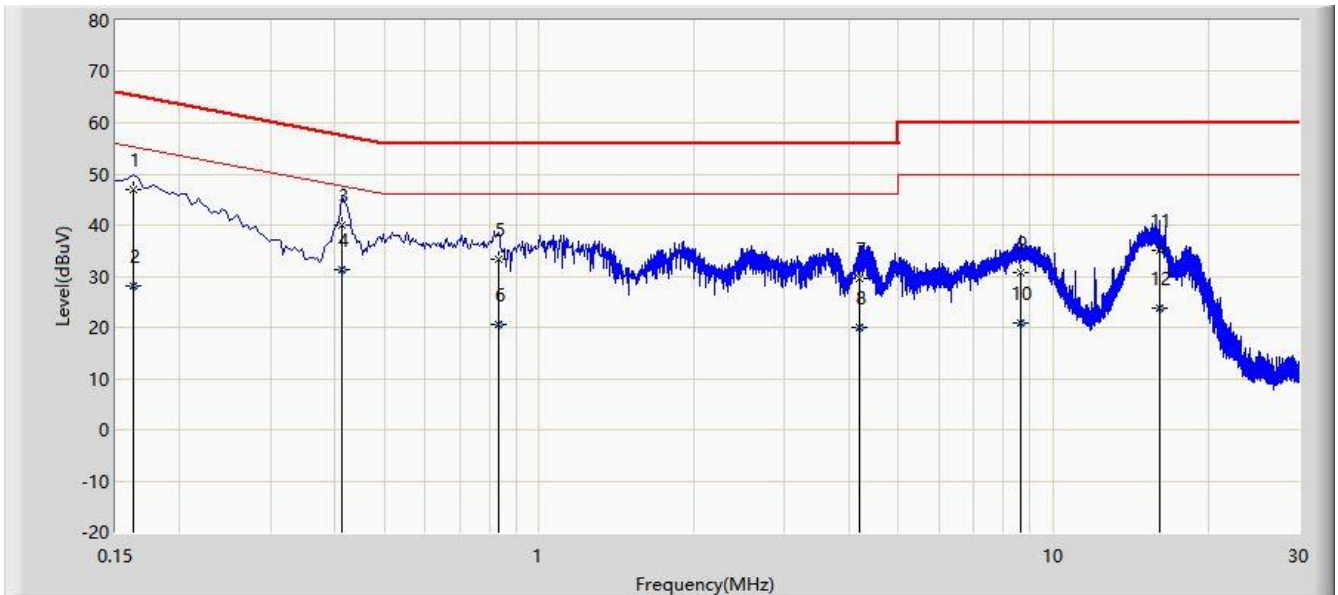

No	Flag	Mark	Frequency (MHz)	Measure Level (dBμV)	Reading Level (dBμV)	Margin (dB)	Limit (dBμV)	Factor (dB)	Type
1			0.162	47.039	37.423	-18.322	65.361	9.616	QP
2			0.162	28.099	18.483	-27.262	55.361	9.616	AV
3			0.414	40.066	30.384	-17.502	57.568	9.682	QP
4		*	0.414	31.197	21.516	-16.370	47.568	9.682	AV
5			0.834	33.407	23.667	-22.593	56.000	9.740	QP
6			0.834	20.463	10.723	-25.537	46.000	9.740	AV
7			4.186	29.706	19.872	-26.294	56.000	9.834	QP
8			4.186	19.962	10.128	-26.038	46.000	9.834	AV
9			8.658	30.782	20.774	-29.218	60.000	10.007	QP
10			8.658	20.870	10.863	-29.130	50.000	10.007	AV
11			16.086	35.156	24.929	-24.844	60.000	10.227	QP
12			16.086	23.690	13.463	-26.310	50.000	10.227	AV

Note: Measure Level (dBμV) = Reading Level (dBμV) + Factor (dB)

Factor (dB) = Cable Loss (dB) + LISN Factor (dB).

Site: WZ-SR2	Time: 2021/02/01
Limit: FCC_Part15.207_CE_AC Power	Engineer: Hyde Yu
Probe: ENV216_101683_Filter Off_Without Adapter	Polarity: Neutral
EUT: WIFI+BT Combo Module	Power: AC 120V/60Hz
Test Mode: Transmit by BLE 2Mbps at Channel 2402MHz	

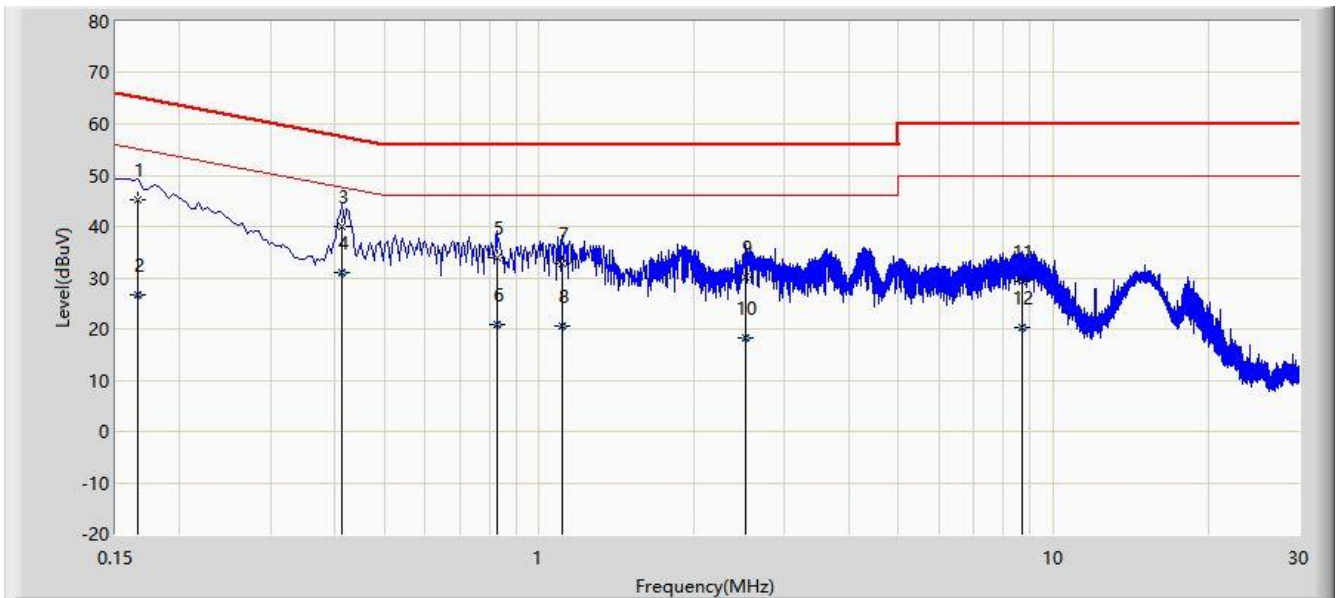

No	Flag	Mark	Frequency (MHz)	Measure Level (dBμV)	Reading Level (dBμV)	Margin (dB)	Limit (dBμV)	Factor (dB)	Type
1			0.166	45.083	35.474	-20.075	65.158	9.609	QP
2			0.166	26.677	17.068	-28.481	55.158	9.609	AV
3			0.414	40.039	30.368	-17.529	57.568	9.672	QP
4		*	0.414	31.034	21.363	-16.533	47.568	9.672	AV
5			0.826	33.844	24.114	-22.156	56.000	9.730	QP
6			0.826	20.752	11.022	-25.248	46.000	9.730	AV
7			1.106	32.732	22.991	-23.268	56.000	9.741	QP
8			1.106	20.623	10.882	-25.377	46.000	9.741	AV
9			2.522	30.064	20.283	-25.936	56.000	9.781	QP
10			2.522	18.178	8.397	-27.822	46.000	9.781	AV
11			8.710	29.199	19.195	-30.801	60.000	10.004	QP
12			8.710	20.343	10.339	-29.657	50.000	10.004	AV

Note: Measure Level (dBμV) = Reading Level (dBμV) + Factor (dB)

Factor (dB) = Cable Loss (dB) + LISN Factor (dB).

7. CONCLUSION

The data collected relate only the item(s) tested and show that the device is in compliance with Part 15C of the FCC rules and ISED rules.

————— The End —————

Appendix A - Test Setup Photograph

Refer to "2101RSU052-UT" file.

Appendix B - EUT Photograph

Refer to " 2101RSU052-UE" file.