



<b>Prüfbericht-Nr.:</b> <i>Test Report No.:</i>	<b>50299853 001</b>	<b>Auftrags-Nr.:</b> <i>Order No.:</i>	238108471	Seite 1 von 58 <i>Page 1 of 58</i>
<b>Kunden-Referenz-Nr.:</b> <i>Client Reference No.:</i>	N/A	<b>Auftragsdatum:</b> <i>Order date:</i>	06-Sep-2019	
<b>Auftraggeber:</b> <i>Client:</i>	Delta Electronics, Inc. 252, Shangying Road, Guishan Industrial Zone, TW-33341 Taoyuan City Taiwan, R.O.C.			
<b>Prüfgegenstand:</b> <i>Test item:</i>	Delta Bluetooth Mono Speaker			
<b>Bezeichnung / Typ-Nr.:</b> <i>Identification / Type No.:</i>	VFRU-19-05BT			
<b>Auftrags-Inhalt:</b> <i>Order content:</i>	FCC Part 15C (BR/EDR)			
<b>Prüfgrundlage:</b> <i>Test specification:</i>	FCC 47CFR Part 15: Subpart C Section 15.247			
<b>Wareneingangsdatum:</b> <i>Date of receipt:</i>	06-Sep-2019			
<b>Prüfmuster-Nr.:</b> <i>Test sample No.:</i>	A000984856-002 A000984856-003			
<b>Prüfzeitraum:</b> <i>Testing period:</i>	28-Sep-2019 – 05-Oct-2019			
<b>Ort der Prüfung:</b> <i>Place of testing:</i>	EMC/RF Laboratory Taipei			
<b>Prüflaboratorium:</b> <i>Testing laboratory:</i>	TUV Rheinland Taiwan Ltd.			
<b>Prüfergebnis*:</b> <i>Test result*:</i>	Pass			
<b>Report date / tested by:</b>		<b>kontrolliert von / reviewed by:</b>		
				
23-Dec-2019	Mars Y.J. Lin / Project Engineer	23-Dec-2019	Arvin Ho / Vice General Manager	
<i>Datum</i> <i>Date</i>	<i>Name / Stellung</i> <i>Name / Position</i>	<i>Unterschrift</i> <i>Signature</i>	<i>Datum</i> <i>Date</i>	<i>Unterschrift</i> <i>Signature</i>
<b>Sonstiges / Other:</b>				
<b>Zustand des Prüfgegenstandes bei Anlieferung:</b> <i>Condition of the test item at delivery:</i>		Prüfmuster vollständig und unbeschädigt <i>Test item complete and undamaged</i>		
* Legende: 1 = sehr gut 2 = gut 3 = befriedigend 4 = ausreichend 5 = mangelhaft P(ass) = entspricht o.g. Prüfgrundlage(n) F(ail) = entspricht nicht o.g. Prüfgrundlage(n) N/A = nicht anwendbar N/T = nicht getestet		Legend: 1 = very good 2 = good 3 = satisfactory 4 = sufficient 5 = poor P(ass) = passed a.m. test specification(s) F(ail) = failed a.m. test specification(s) N/A = not applicable N/T = not tested		
<b>Dieser Prüfbericht bezieht sich nur auf das o.g. Prüfmuster und darf ohne Genehmigung der Prüfstelle nicht auszugsweise vervielfältigt werden. Dieser Bericht berechtigt nicht zur Verwendung eines Prüfzeichens.</b> <i>This test report only relates to the a. m. test sample. Without permission of the test center this test report is not permitted to be duplicated in extracts. This test report does not entitle to carry any test mark.</i>				



## TEST SUMMARY

**5.1.1 ANTENNA REQUIREMENT***RESULT: Passed***5.1.2 PEAK OUTPUT POWER***RESULT: Passed***5.1.3 20dB BANDWIDTH***RESULT: Passed***5.1.4 99% BANDWIDTH***RESULT: Passed***5.1.5 CONDUCTED SPURIOUS EMISSIONS AND FREQUENCY BAND EDGE MEASURED IN 100KHZ BANDWIDTH***RESULT: Passed***5.1.6 SPURIOUS EMISSION***RESULT: Passed***5.1.7 FREQUENCY SEPARATION***RESULT: Passed***5.1.8 NUMBER OF HOPPING FREQUENCY***RESULT: Passed***5.1.9 TIME OF OCCUPANCY***RESULT: Passed***5.1.10 MAINS CONDUCTED EMISSIONS***RESULT: Passed***6.1.1 ELECTROMAGNETIC FIELDS***RESULT: Passed*

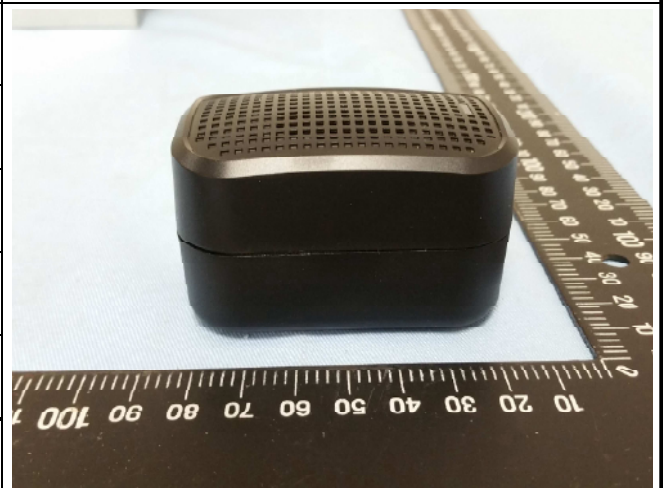
## Contents

<b>1.</b>	<b>GENERAL REMARKS .....</b>	<b>5</b>
<b>1.1</b>	<b>COMPLEMENTARY MATERIALS.....</b>	<b>5</b>
<b>2.</b>	<b>TEST SITES .....</b>	<b>6</b>
<b>2.1</b>	<b>TEST LABORATORY .....</b>	<b>6</b>
<b>2.2</b>	<b>TEST FACILITY.....</b>	<b>6</b>
<b>2.3</b>	<b>LIST OF TEST AND MEASUREMENT INSTRUMENTS.....</b>	<b>7</b>
<b>2.4</b>	<b>TRACEABILITY .....</b>	<b>8</b>
<b>2.5</b>	<b>CALIBRATION .....</b>	<b>8</b>
<b>2.6</b>	<b>MEASUREMENT UNCERTAINTY .....</b>	<b>8</b>
<b>3.</b>	<b>GENERAL PRODUCT INFORMATION.....</b>	<b>9</b>
<b>3.1</b>	<b>PRODUCT FUNCTION AND INTENDED USE .....</b>	<b>9</b>
<b>3.2</b>	<b>SYSTEM DETAILS AND RATINGS.....</b>	<b>9</b>
<b>3.3</b>	<b>INDEPENDENT OPERATION MODES.....</b>	<b>11</b>
<b>3.4</b>	<b>NOISE GENERATING AND NOISE SUPPRESSING PARTS .....</b>	<b>12</b>
<b>3.5</b>	<b>SUBMITTED DOCUMENTS.....</b>	<b>12</b>
<b>4.</b>	<b>TEST SET-UP AND OPERATION MODES.....</b>	<b>13</b>
<b>4.1</b>	<b>PRINCIPLE OF CONFIGURATION SELECTION .....</b>	<b>13</b>
<b>4.2</b>	<b>TEST OPERATION AND TEST SOFTWARE.....</b>	<b>13</b>
<b>4.3</b>	<b>SPECIAL ACCESSORIES AND AUXILIARY EQUIPMENT .....</b>	<b>14</b>
<b>4.4</b>	<b>COUNTERMEASURES TO ACHIEVE EMC COMPLIANCE.....</b>	<b>15</b>
<b>4.5</b>	<b>TEST SETUP DIAGRAM .....</b>	<b>15</b>
<b>5.</b>	<b>TEST RESULTS .....</b>	<b>17</b>
<b>5.1</b>	<b>TRANSMITTER REQUIREMENT &amp; TEST SUITES .....</b>	<b>17</b>
<b>5.1.1</b>	<i>Antenna Requirement .....</i>	<i>17</i>
<b>5.1.2</b>	<i>Peak Output Power .....</i>	<i>18</i>
<b>5.1.3</b>	<i>20dB Bandwidth .....</i>	<i>20</i>
<b>5.1.4</b>	<i>99% Bandwidth .....</i>	<i>27</i>
<b>5.1.5</b>	<i>Conducted spurious emissions and Frequency Band Edge measured in 100kHz Bandwidth.....</i>	<i>33</i>
<b>5.1.6</b>	<i>Spurious Emission .....</i>	<i>40</i>
<b>5.1.7</b>	<i>Frequency Separation.....</i>	<i>41</i>
<b>5.1.8</b>	<i>Number of hopping frequency.....</i>	<i>44</i>
<b>5.1.9</b>	<i>Time of Occupancy .....</i>	<i>48</i>
<b>MAINS EMISSIONS .....</b>		<b>52</b>
<b>5.1.10</b>	<i>Mains Conducted Emissions.....</i>	<i>52</i>

<b>6.</b>	<b>SAFETY HUMAN EXPOSURE .....</b>	<b>53</b>
<b>6.1</b>	<b>RADIO FREQUENCY EXPOSURE COMPLIANCE .....</b>	<b>53</b>
6.1.1	<i>Electromagnetic Fields.....</i>	<i>53</i>
<b>7.</b>	<b>PHOTOGRAPHS OF THE TEST SET-UP.....</b>	<b>54</b>
<b>8.</b>	<b>LIST OF TABLES .....</b>	<b>58</b>
<b>9.</b>	<b>LIST OF PHOTOGRAPHS.....</b>	<b>58</b>

## 1. General Remarks

### 1.1 Complementary Materials

The following attachments are integral parts of this test report:

**Appendix P: Photo Documentation**

(File Name: 50299853 001 APPENDIX P)

**Appendix D: Test Result of Radiated Emissions**

(File Name: 50299853 001 APPENDIX D)

Test Specifications

The following standards were applied

**Table 1: Applied Standard and Test Levels**

<b>Radio</b>
FCC CFR47 Part 15: Subpart C Section 15.247
FCC 47CFR Part 2: Subpart J section 2.1091
ANSI C63.10:2013
KDB558074 D01 DTS Meas Guidance v05

## 2. Test Sites

### 2.1 Test Laboratory

TUV Rheinland Taiwan Ltd.

11F. No.758, Sec. 4, Bade Rd., Songshan Dist.  
Taipei City 105  
Taiwan (R.O.C.)

### 2.2 Test Facility

TUV Rheinland Taiwan Ltd.

Radiated and Mains conduction tested as below facility:  
11F. No.758, Sec. 4, Bade Rd., Songshan Dist.  
Taipei City 105  
Taiwan (R.O.C.)  
FCC Registration No.: 180491  
IC Canada Registration No.: 9465A

Conducted tested at below facility:  
No. 458-18, Sec 2, Fenliao., Linkou Dist.  
New Taipei City 244  
Taiwan (R.O.C.)  
FCC Registration No.: 226631  
IC Canada Registration No.: 25563

TAF Accredited NCC Test Lab. No.:3567  
TAF ISO17025 Certification effective period: 6<sup>th</sup>-May-2019 to 05<sup>th</sup>-May-2022



Testing Laboratory  
3567

## 2.3 List of Test and Measurement Instruments

**Table 2: List of Test and Measurement Equipment**

Kind of Equipment	Manu-facturer	Type	S/N	Last Calibration	Next Calibration
Test Software	Audix	e3	Ver.9	N/A	N/A
EMI Test Receiver	R&S	ESR 7	101549	2018/11/12	2019/11/10
Spectrum Analyzer	R&S	FSV 40	100921	2019/04/30	2020/04/30
Preamplifier (30MHz -1GHz)	Hewlett Packard	8447D	2944A06641	2019/01/08	2020/01/08
Preamplifier (18 GHz -40 GHz)	EMC Instruments	EMC184045SE	980652	2019/02/25	2020/02/25
Pre-Amplifier (1GHz~18GHz)	EM Electronics	EM01G18G	60649	2019/09/11	2020/09/11
Bilog Antenna	TESEQ	CBL 6111D	29804	2019/07/12	2020/07/12
Horn Antenna	ETS-Lindgren	3117	218931	2018/12/27	2019/12/27
Horn Antenna (18GHz~40GHz)	COM-POWER	AH-840	101029	2018/12/22	2019/12/22
Loop Antenna	Schwarzbeck	FMZB 1513	1513-076	2019/07/11	2020/07/11
Temp. & Humid. Chamber	Giant Force	GCT-099-40-S	MAF0103-007	2019/04/16	2020/04/15
EMI Test Receiver	R&S	ESCI 7	100797	2019/01/16	2020/01/16
LISN (1 phase)	R&S	ENV216	101243	2019/06/23	2020/06/23
LISN	R&S	ENV216	101262	2019/07/16	2020/07/16
EXA Signal Analyzer	KEYSIGHT	N9010A	MY53470241	2019/02/15	2020/02/15
power Meter	Anritsu	ML2495A	1901008	2019/04/29	2020/04/28
Power Sensor	Anritsu	MA2411B	1725269	2019/04/29	2020/04/28

## 2.4 Traceability

All measurement equipment calibrations are traceable to NML(Taiwan)/NIST(USA) or where calibration is performed outside Taiwan, to equivalent nationally recognized standards organizations.

## 2.5 Calibration

Equipment requiring calibration is calibrated periodically by the manufacturer or according to manufacturer's specifications. Additionally all equipment is verified for proper performance on a regular basis using in house standards or comparisons.

## 2.6 Measurement Uncertainty

The estimated combined standard uncertainty for radiated emissions and conducted emissions measurements:.

**Table 3: Emission Measurement Uncertainty**

Parameter	Uncertainty
Radio Frequency	± 0.1 ppm
RF power, conducted	± 1.5 dB
Adjacent channel power	± 3 dB
Radiated emission of transmitter, valid up to 26 GHz	± 6 dB
Radiated emission of receiver, valid up to 26 GHz	± 6 dB
Temperature	± 2 °C
Humidity	± 10 %



## 3. General Product Information

### 3.1 Product Function and Intended Use

The EUT is a Bluetooth Speaker. It contains a Bluetooth BR/EDR compatible module enabling the user to communicate data through a Wireless interface.  
For details refer to the User Guide, Data Sheet and Circuit Diagram.

### 3.2 System Details and Ratings

**Table 4: Basic Information of EUT**

Item	EUT information
Kind of Equipment/Test Item	Delta Bluetooth Mono Speaker
Type Identification	VFRU-19-05BT
FCC ID	H79VFRU-19-25BT

**Table 5: Technical Specification of EUT**

Technical Specification	Value
Operating Frequency	2402 MHz ~ 2480 MHz
Channel Spacing	1 MHz
Channel number	79
Operation Voltage	5Vdc
Modulation	GFSK, $\pi/4$ DQPSK, 8 DPSK
Antenna gain	0 dBi

**Table 6: Frequency hopping information**

Technical Specification	Description
Hopping Range	<p>Hereby we declare that the maximum frequency of this device is: 2402-2480MHz. This is according the Bluetooth Core Specification V2.1+EDR for devices which will be operated in the USA. This was checked during the Bluetooth Qualification tests (Test Case: TRM/CA/04).</p>
Hopping Sequence	<p>Example of a 79 hopping sequence in data mode:</p> <p>33,04,21,44,23,42,53,46,55,48,40,59,72,29,76,31,08,73,07,75,09,45,60,39,58,13,47,11,77,52,35,50,65,54,67,56,69,62,71,64, 7,25,27,66,57,70,74,61,78,63,10,41,05,43,15,44,64,68,02,70,06,01,51,03,55,05,03,66,53,49,36,47,</p>
Receiver input bandwidth	<p>The input bandwidth of the receiver is 1MHz. In every connection one Bluetooth device is the master and the other one is the slave. The master determines the hopping sequence. The slave follows this sequence. Both devices shift between RX and TX time slot according to the clock of the master.</p> <p>Additionally the type of connection is set up at the beginning of the connection. The master adapts its hopping frequency and its TX/RX timing according to the packet type of the connection. Also the slave of the connection will use these settings.</p> <p>Repeating of a packer has no influence on the hopping sequence. The hopping sequence generated by the master of the connection will be followed in any case.</p> <p>That means a repeated packet will not be send on the same frequency, it is send on the next frequency of the hopping sequence.</p>

### 3.3 Independent Operation Modes

The basic operation modes are:

- A. Transmitting
  - 1. Low channel
  - 2. Middle channel
  - 3. High channel
  
- B. Receiving
  - 1. Low channel
  - 2. Middle channel
  - 3. High channel
  
- C. Hopping

### **3.4 Noise Generating and Noise Suppressing Parts**

Refer to the Circuit Diagram.

### **3.5 Submitted Documents**

- Circuit Diagram
- Instruction Manual
- Rating Label
- Technical Description

## 4. Test Set-up and Operation Modes

### 4.1 Principle of Configuration Selection

The test modes were adapted accordingly in reference to the instructions for use.

During testing, Channel and Power Controlling Software provided by the customer was used to control the operating channel as well as the output power level. The RF output power selection is for the setting of RF output power expected by the customer and is going to be fixed on the firmware of the final end product.

**Table 7: Table for Parameters of Test Software Setting**

Mode	Channel Frequency		
	2402 MHz	2441 MHz	2480 MHz
1-DH5	3	3	3
2-DH5	3	3	3
3-DH5	3	3	3

### 4.2 Test Operation and Test Software

Test operation refers to test setup in chapter 4. All testing were performed according to the procedures in ANSI C63.10: 2013

The samples were used as follows:

Conducted: A000984856-002

Radiation: A000984856-003

Full test was applied on all test modes, but only worst case was shown.

Test Software	BK3256 RF Test_V1.3
---------------	---------------------

### 4.3 Special Accessories and Auxiliary Equipment

The product has been tested together with the following additional accessories:

Description	Manufacturer	Model No.	Serial No.
Notebook(EMC-06)	Lenovo	TP00048A	PB-0F8B2

## 4.4 Countermeasures to achieve EMC Compliance

The test sample which has been tested containing the noise suppression parts as in the Photo Appendix and the Test Setup Photos. No additional measures were employed to achieve compliance.

## 4.5 Test Setup Diagram

Diagram of Measurement Configuration for Radiation Test

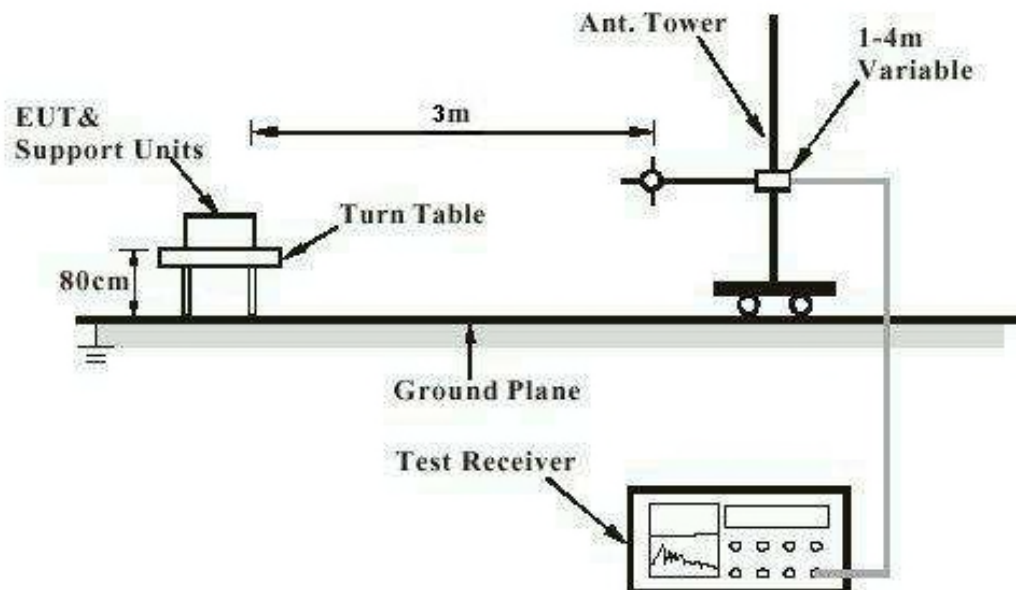

Note: Measurements above 1 GHz are done with a table height of 1.5m

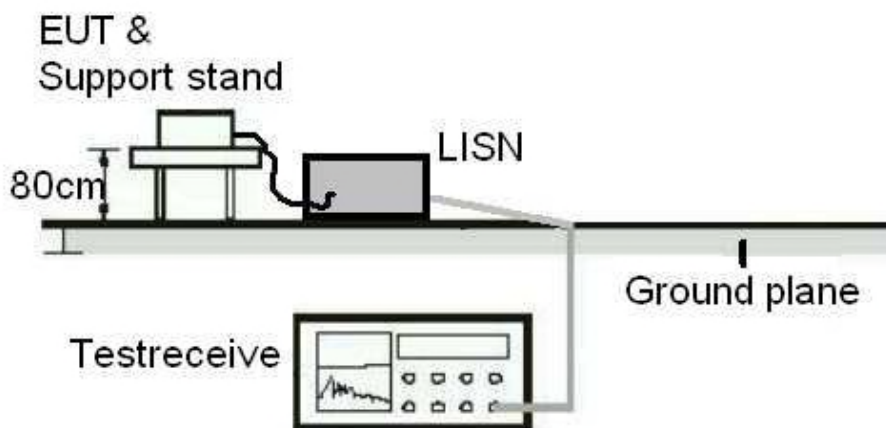
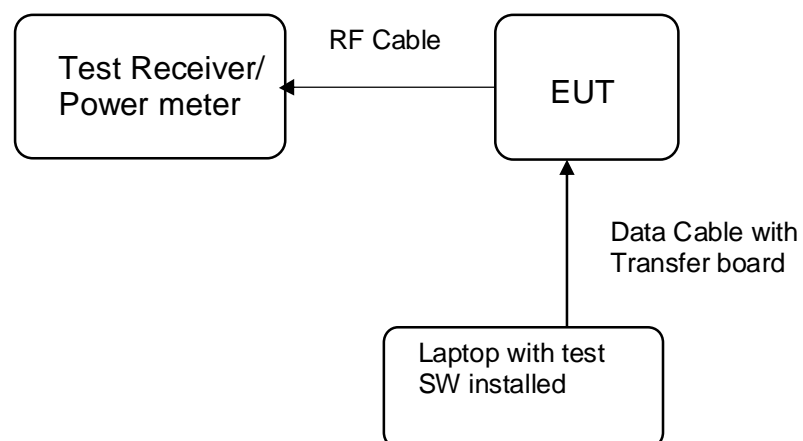
**Diagram of Measurement Equipment Configuration for Mains Conduction Measurement**

**Diagram of Measurement Equipment Configuration for Conducted Transmitter Measurement**



## 5. Test Results

### 5.1 Transmitter Requirement & Test Suites

#### 5.1.1 Antenna Requirement

**RESULT:** **Passed**

Test standard : FCC Part 15.247(b)(4)

Requirement : use of approved antennas only with directional gains that do not exceed 6 dBi

According to the manufacturer declaration, the EUT has an antenna with a directional gain of 0 dBi . The antenna is a printed PCB trace with no possibility of replacement with a non-approved antenna by the end-user. Therefore, the EUT is considered to comply with this provision.

Refer to EUT photo for details.

### 5.1.2 Peak Output Power

**RESULT:**
**Passed**

Test standard : FCC Part 15.247(b)(1)  
 Basic standard : ANSI C63.10:2013  
 Kind of test site : Shielded room

**Test setup**

Test Channel : Low/ Middle/ High  
 Operation Mode : A  
 Test Lab. : Linkou  
 Ambient temperature : 22-26 °C  
 Relative humidity : 50-65 %  
 Atmospheric pressure : 100-103 kPa

**Table 8: Test result of Peak Output Power, 1DH5**

Channel	Channel Frequency	Peak Output Power		Limit
	(MHz)	(dBm)	(W)	(dBm)
Low Channel	2402	-1.54	0.00070	21
Middle Channel	2441	-1.78	0.00066	21
High Channel	2480	-1.99	0.00063	21

**Table 9: Test result of Peak Output Power, 2DH5**

Channel	Channel Frequency	Peak Output Power		Limit
	(MHz)	(dBm)	(W)	(dBm)
Low Channel	2402	0.61	0.00115	21
Middle Channel	2441	0.57	0.00114	21
High Channel	2480	0.49	0.00112	21

**Table 10: Test result of Peak Output Power, 3DH5**

Channel	Channel Frequency	Peak Output Power		Limit
	(MHz)	(dBm)	(W)	(dBm)
Low Channel	2402	1.06	0.00128	21
Middle Channel	2441	0.73	0.00118	21
High Channel	2480	0.62	0.00115	21

**Table 11: Test result of Avg Output Power, 1DH5**

Channel	Channel Frequency	Peak Output Power		Limit
	(MHz)	(dBm)	(W)	(dBm)
Low Channel	2402	-1.92	0.00064	21
Middle Channel	2441	-2.26	0.00059	21
High Channel	2480	-2.49	0.00056	21

**Table 12: Test result of Avg Output Power, 2DH5**

Channel	Channel Frequency	Peak Output Power		Limit
	(MHz)	(dBm)	(W)	(dBm)
Low Channel	2402	-1.69	0.00068	21
Middle Channel	2441	-1.91	0.00064	21
High Channel	2480	-2.01	0.00063	21

**Table 13: Test result of Avg Output Power, 3DH5**

Channel	Channel Frequency	Peak Output Power		Limit
	(MHz)	(dBm)	(W)	(dBm)
Low Channel	2402	-1.67	0.00068	21
Middle Channel	2441	-2.01	0.00063	21
High Channel	2480	-2.19	0.00060	21

Max. Average output power: -1.67dBm (0.6808mW)

### 5.1.3 20dB Bandwidth

**RESULT:**
**Passed**

Test standard : FCC Part 15.247(a)(1)  
 Basic standard : ANSI C63.10:2013  
 Kind of test site : Shielded room

**Test setup**

Test Channel : Low/ Middle/ High  
 Operation Mode : A  
 Test Lab. : Linkou  
 Ambient temperature : 22-26°C  
 Relative humidity : 50-65%  
 Atmospheric pressure : 100-103kPa

**Table 14: Test result of 20dB Bandwidth, 1DH5**

Channel	Channel Frequency (MHz)	20dB Bandwidth (kHz)	Limit (MHz)	Result
Low Channel	2402	981.2	1.5	Pass
Mid Channel	2441	972.5	1.5	Pass
High Channel	2480	975.4	1.5	Pass

Note: Limit is for Channel Separation of 1 MHz and a power limit of 125 mW.

**Table 15: Test result of 20dB Bandwidth, 2DH5**

Channel	Channel Frequency (MHz)	20dB Bandwidth (MHz)	Limit (MHz)	Result
Low Channel	2402	1.369	1.5	Pass
Mid Channel	2441	1.374	1.5	Pass
High Channel	2480	1.369	1.5	Pass

Note: Limit is for Channel Separation of 1 MHz and a power limit of 125 mW.

If the carrier separation frequency of a Bluetooth Device is set at 1 MHz due to the firmware setting and the Bluetooth Standard, then for power <125 mW the limit for the 20 dB Bandwidth, becomes 1 MHz / 0.66666 = 1.5 MHz.

**Table 16: Test result of 20dB Bandwidth, 3DH5**

Channel	Channel Frequency (MHz)	20dB Bandwidth (MHz)	Limit (MHz)	Result
Low Channel	2402	1.360	1.5	Pass
Mid Channel	2441	1.357	1.5	Pass
High Channel	2480	1.351	1.5	Pass

## Test Plot of 20dB Bandwidth, 1DH5

### Low Channel

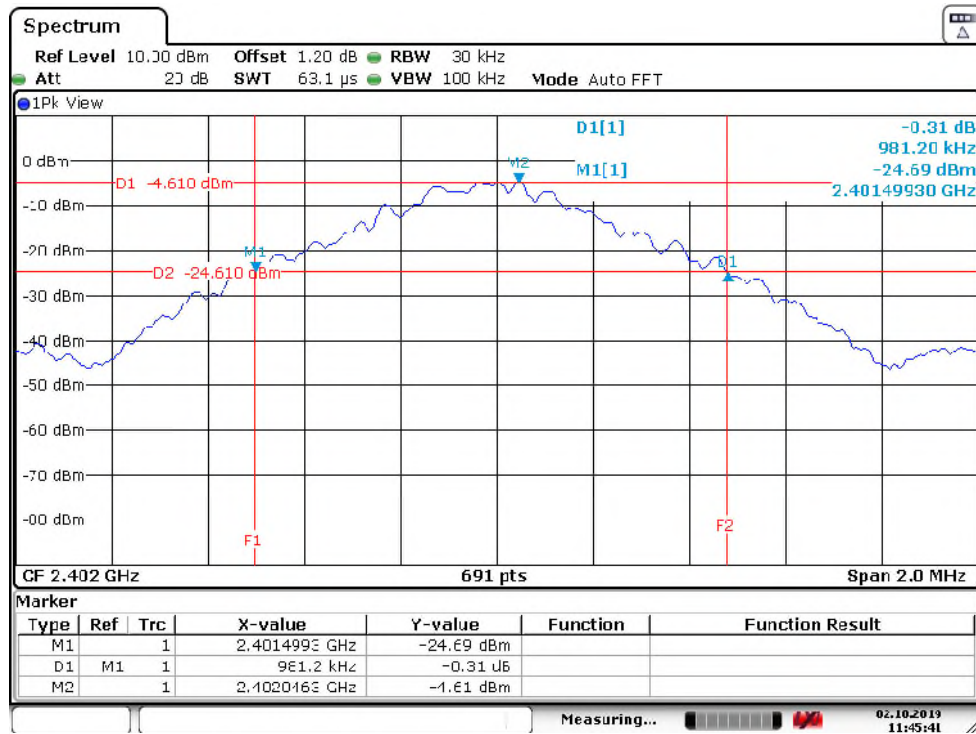

Date: 2.OCT.2019 11:45:42

### Middle Channel

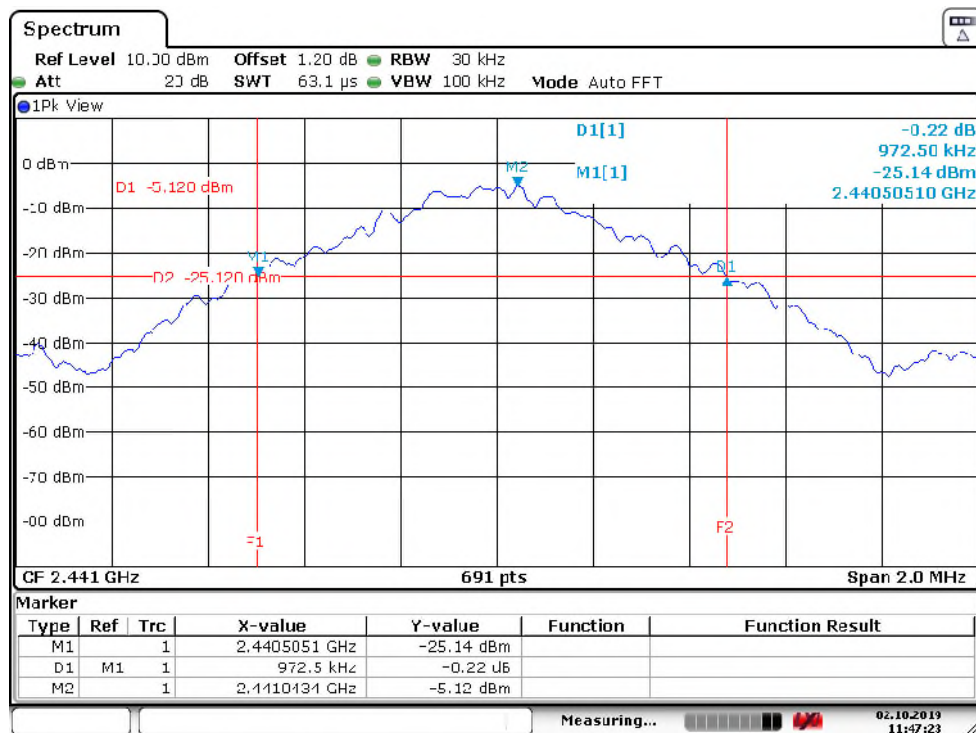

Date: 2.OCT.2019 11:47:23

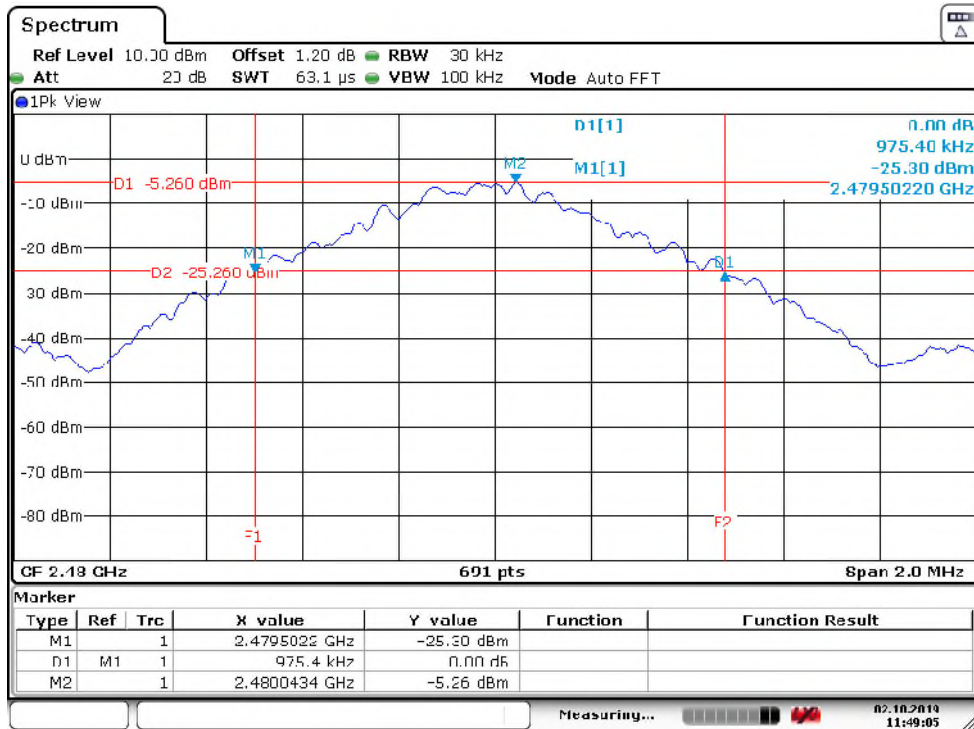
**High Channel**

Date: 2.OCT.2019 11:49:05

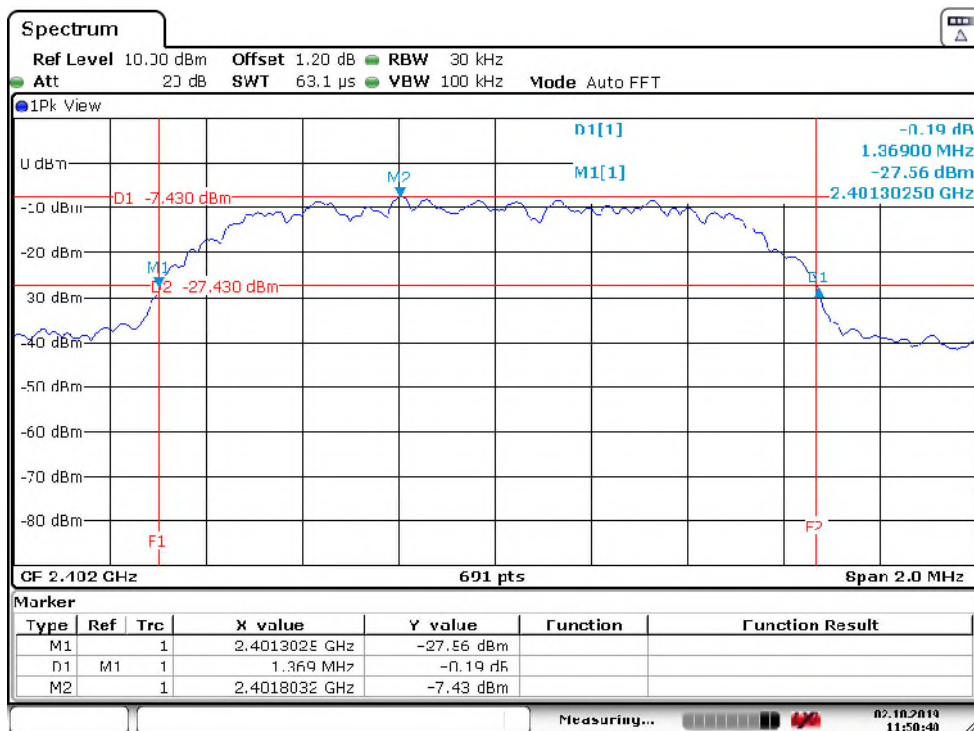
**Test Plot of 20dB Bandwidth, 2DH5**
**Low Channel**

Date: 2.OCT.2019 11:50:41

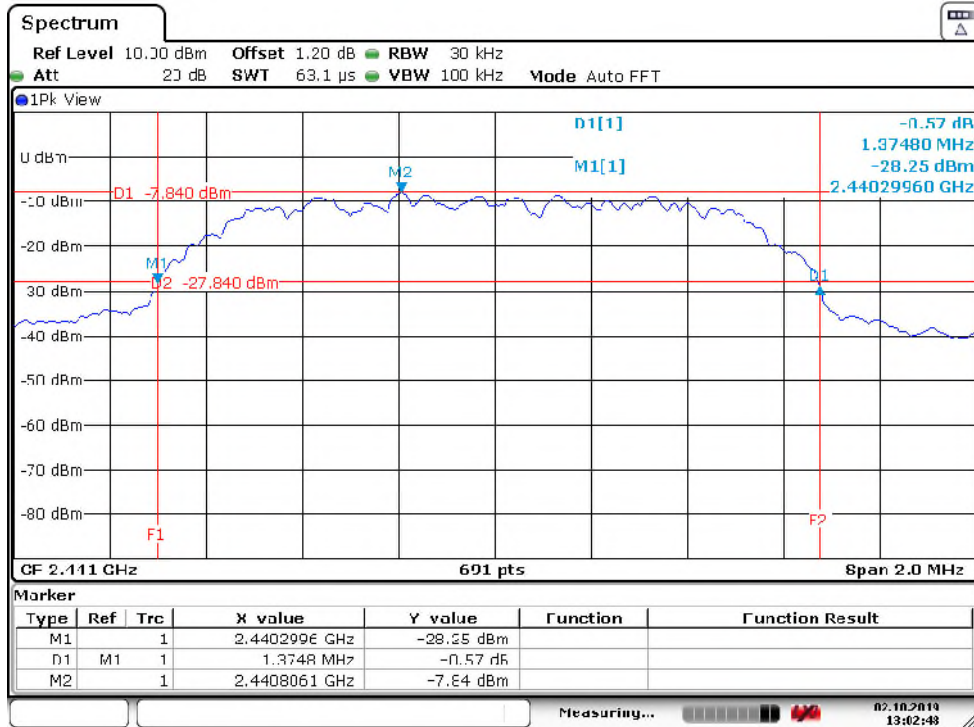
**Middle Channel**

Date: 2.OCT.2019 13:02:49

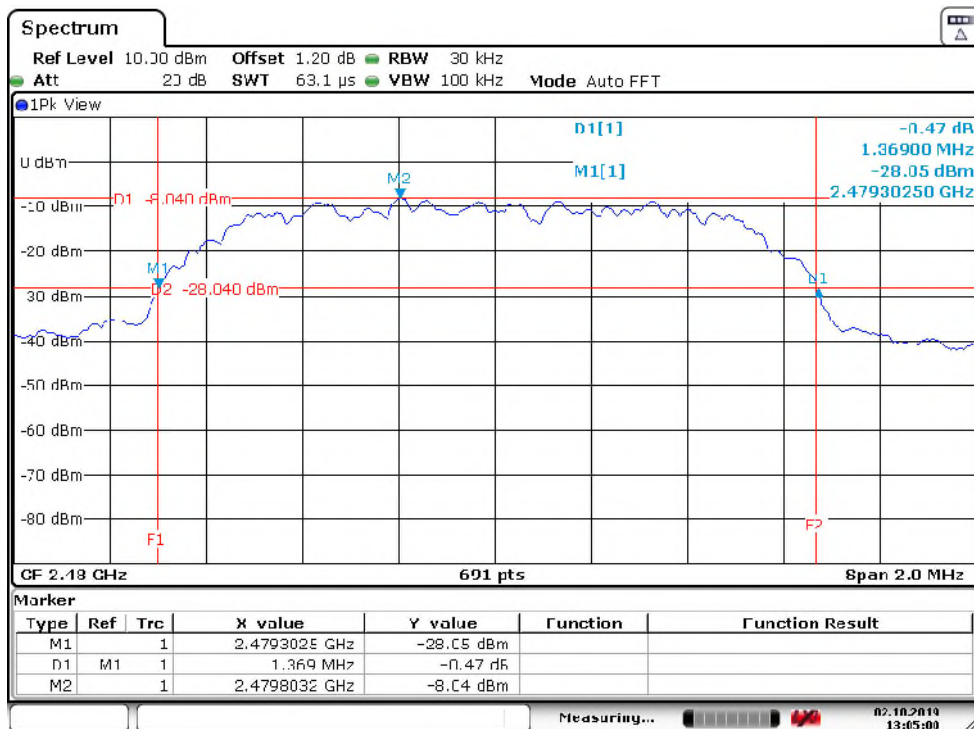
**High Channel**

Date: 2.OCT.2019 13:05:01



## Test Plot of 20dB Bandwidth, 3DH5

### Low Channel

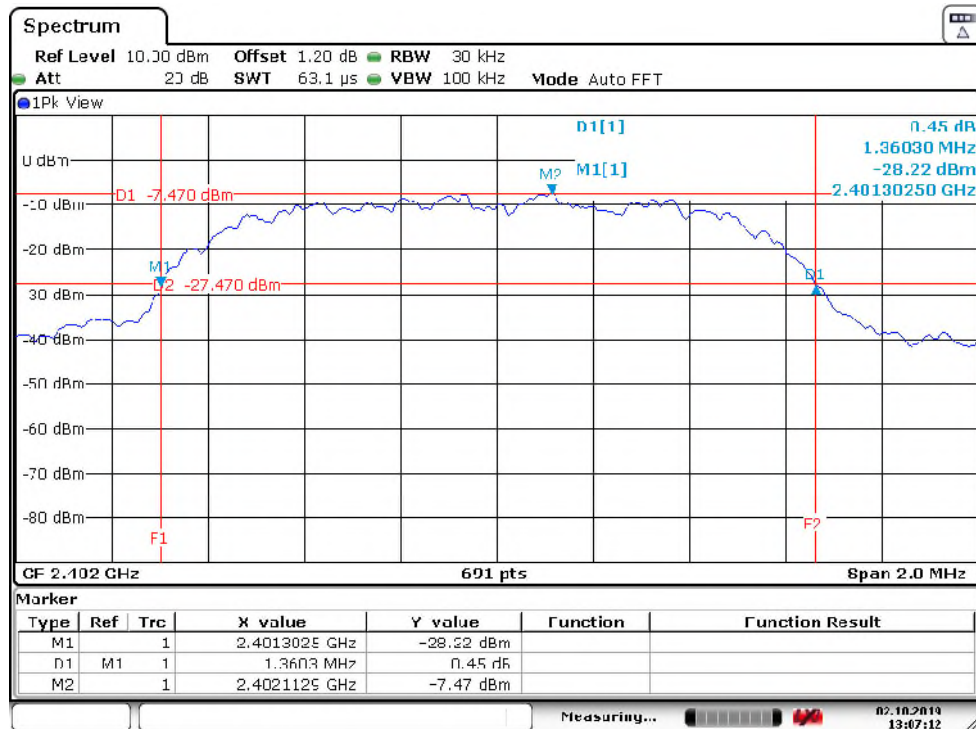

Date: 2.OCT.2019 13:07:12

### Middle Channel

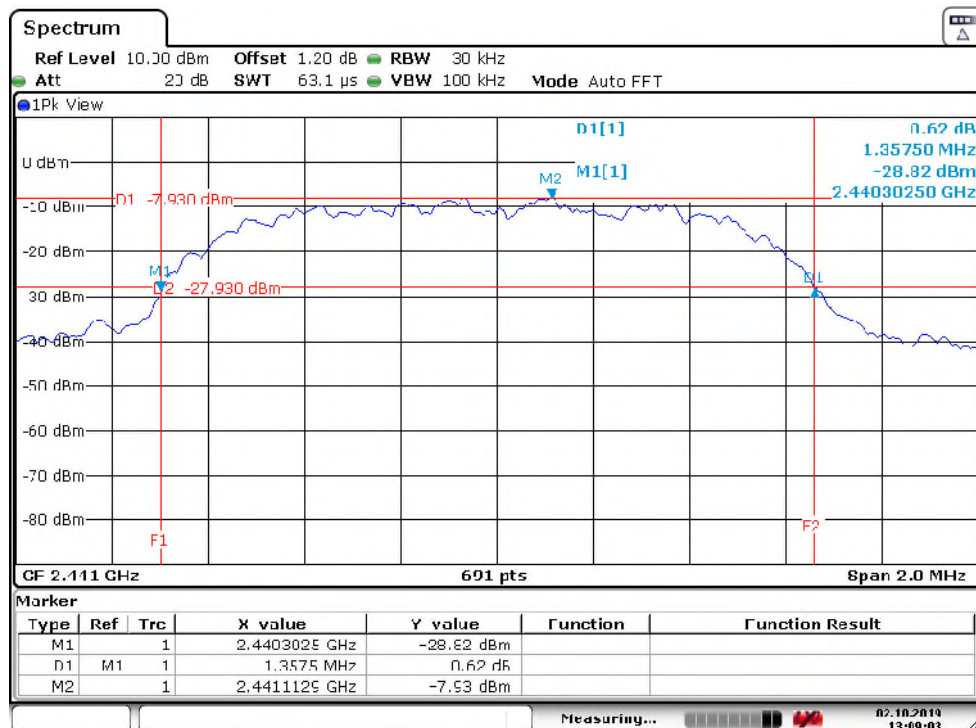

Date: 2.OCT.2019 13:09:03

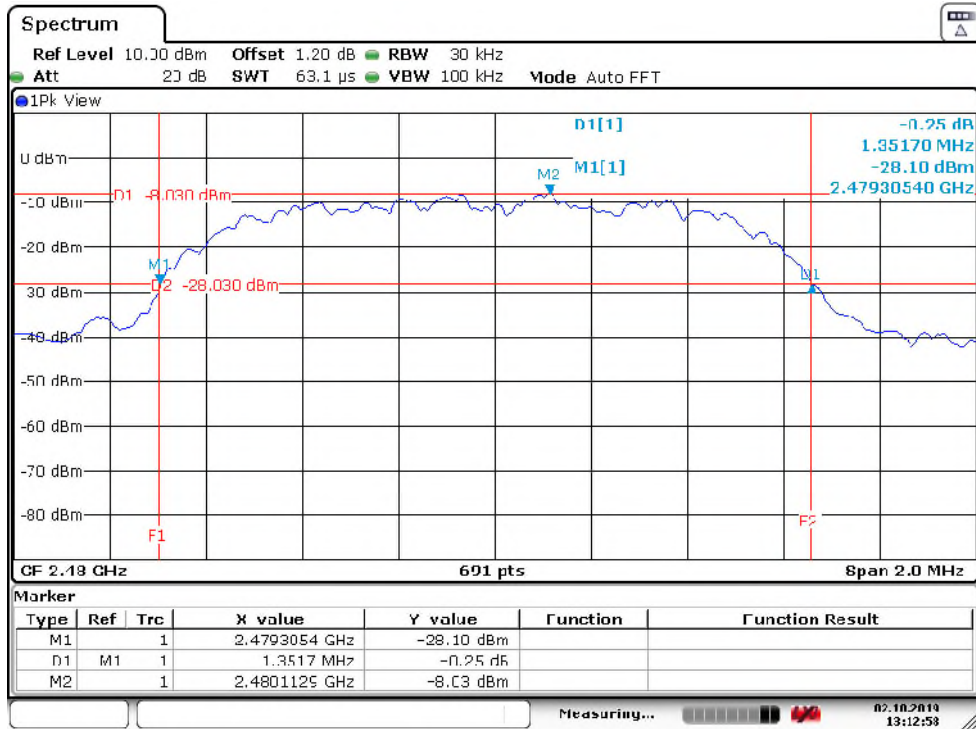
**High Channel**

Date: 2.OCT.2019 13:12:58

### 5.1.4 99% Bandwidth

**RESULT:**
**Passed**

Test standard : FCC Part 15.247(a)(1)  
 Basic standard : ANSI C63.10:2013  
 Kind of test site : Shielded room

**Test setup**

Test Channel : Low/ Middle/ High  
 Operation Mode : A  
 Test Lab. : Linkou  
 Ambient temperature : 22-26°C  
 Relative humidity : 50-65%  
 Atmospheric pressure : 100-103kPa

**Table 17: Test result of 99% Bandwidth, 1DH5**

Channel	Channel Frequency (MHz)	99% Bandwidth (kHz)
Low Channel	2402	916.063
Mid Channel	2441	916.063
High Channel	2480	920.405

**Table 18: Test result of 99% Bandwidth, 2DH5**

Channel	Channel Frequency (MHz)	99% Bandwidth (MHz)
Low Channel	2402	1.2286
Mid Channel	2441	1.2243
High Channel	2480	1.2286

**Table 19: Test result of 99% Bandwidth, 3DH5**

Channel	Channel Frequency (MHz)	99% Bandwidth (kHz)
Low Channel	2402	1.2199
Mid Channel	2441	1.2199
High Channel	2480	1.2199

## Test Plot of 99% Bandwidth, 1DH5

### Low Channel

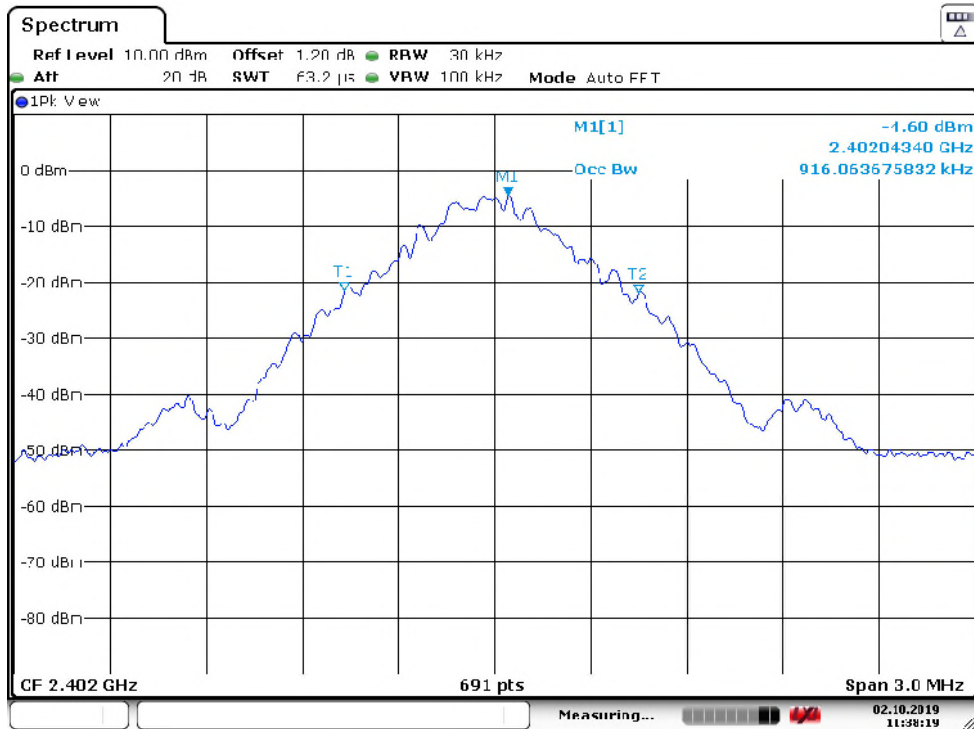

Date: 2.OCT.2019 11:38:19

### Middle Channel

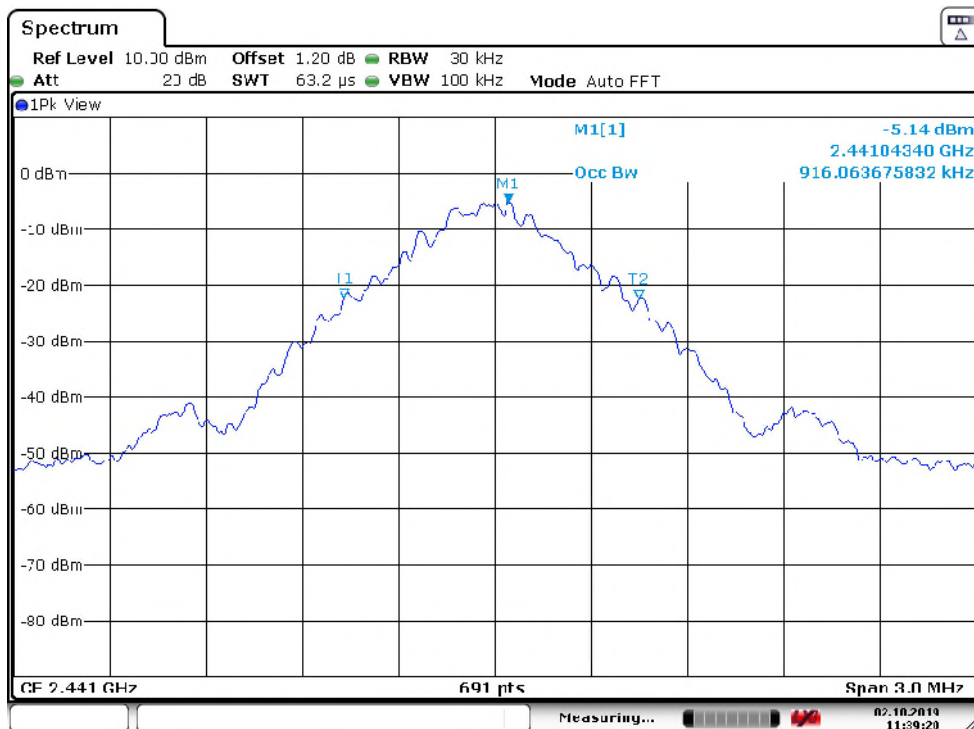

Date: 2.OCT.2019 11:39:20

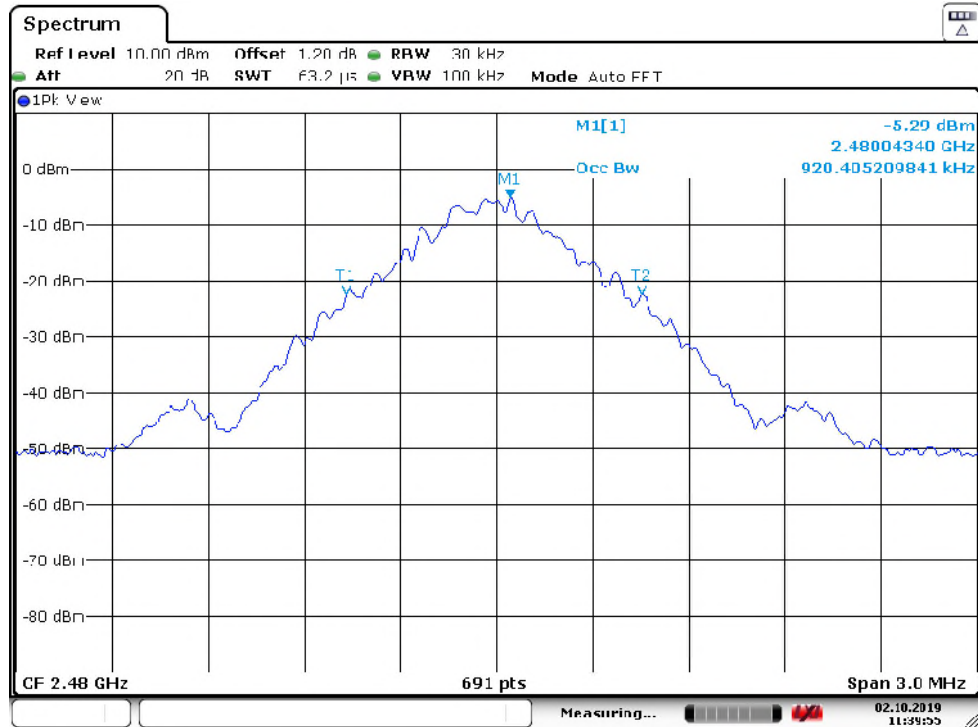
**High Channel**

Date: 2.OCT.2019 11:39:55

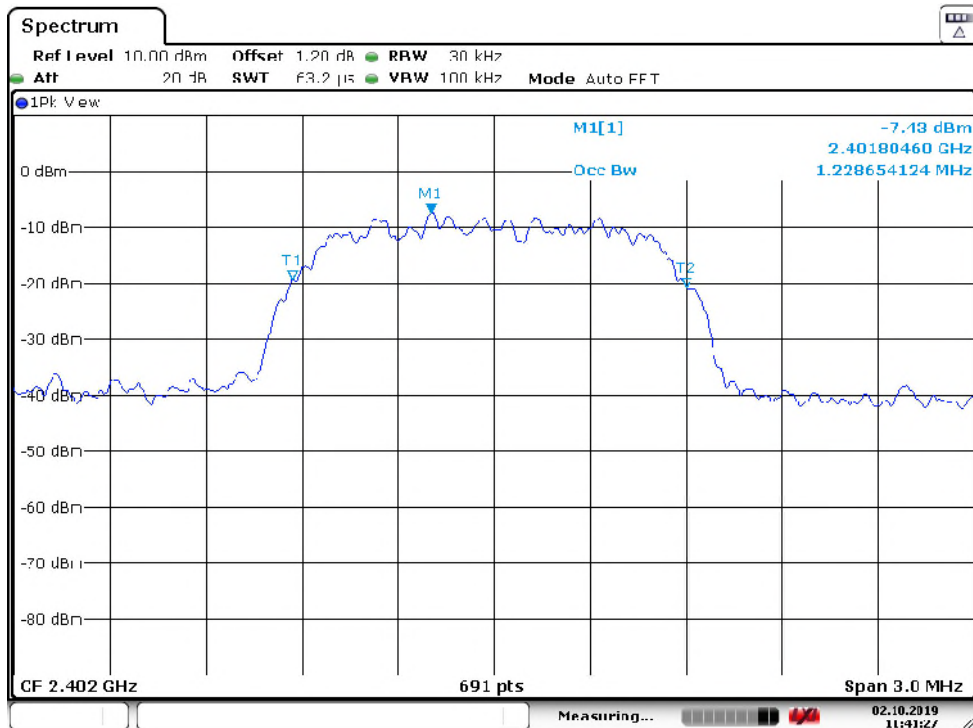
**Test Plot of 99% Bandwidth, 2DH5**
**Low Channel**

Date: 2.OCT.2019 11:41:28

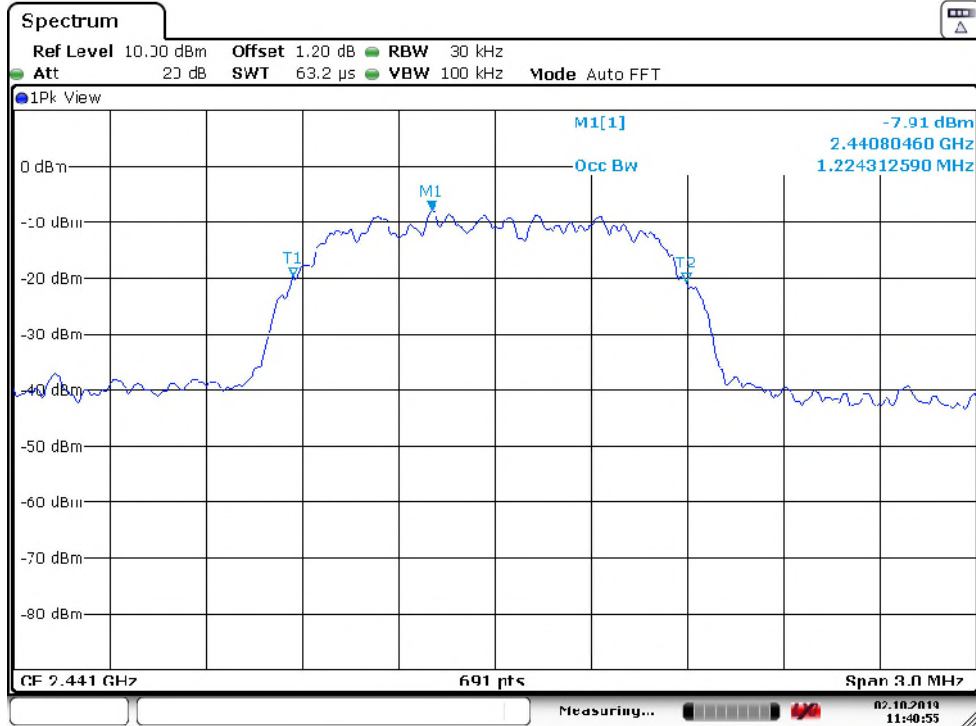
**Middle Channel**

Date: 2.OCT.2019 11:40:55

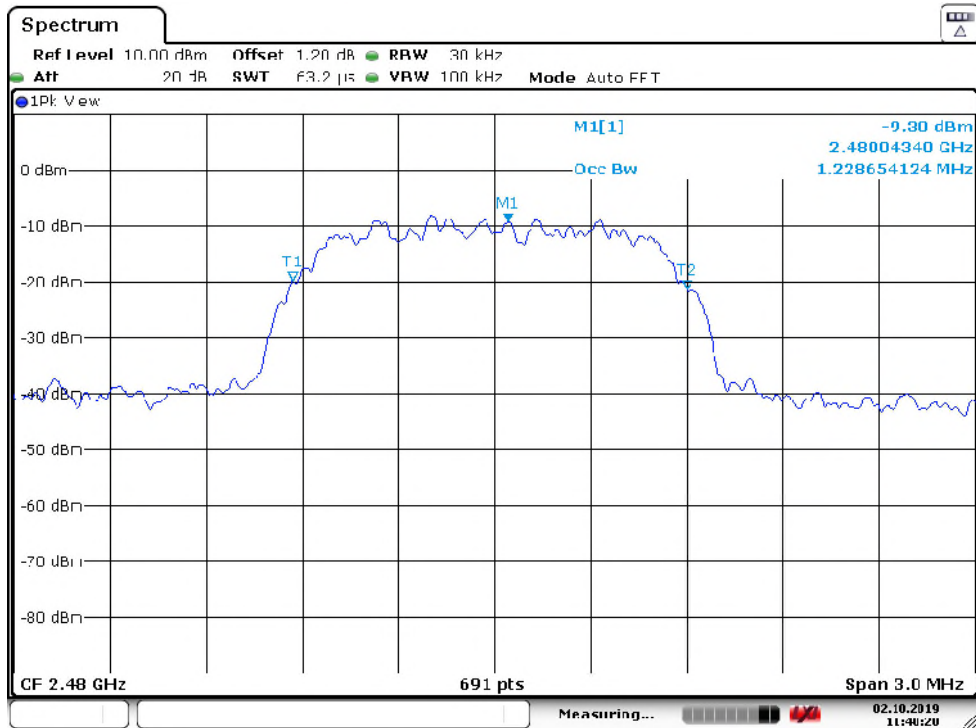
**High Channel**

Date: 2.OCT.2019 11:40:20

## Test Plot of 99% Bandwidth, 3DH5

### Low Channel

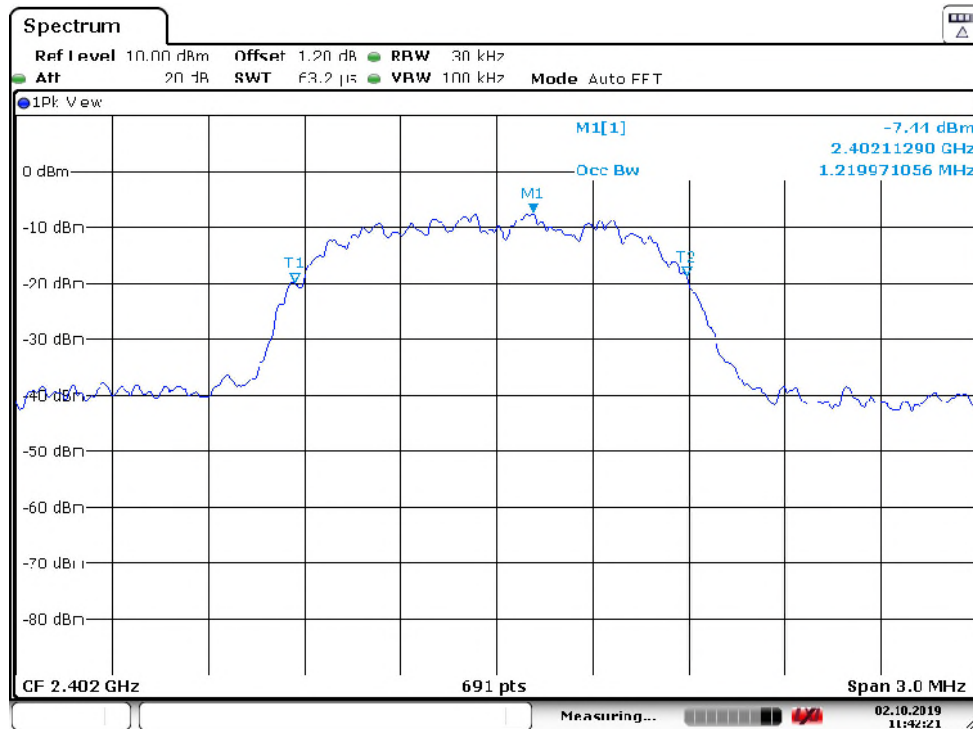

Date: 2.OCT.2019 11:42:21

### Middle Channel

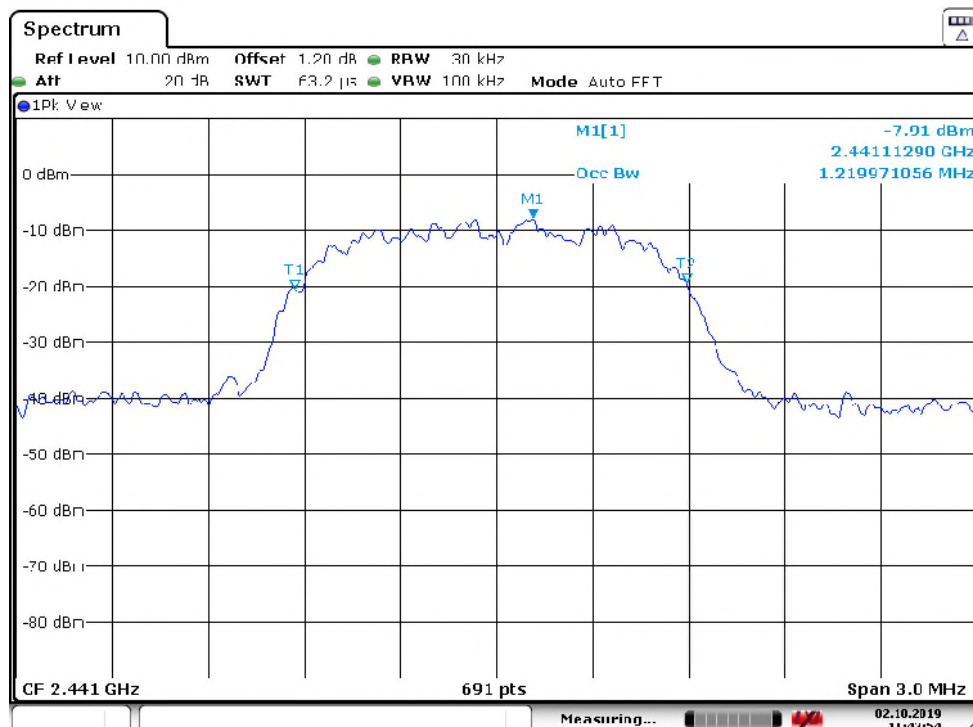

Date: 2.OCT.2019 11:42:55

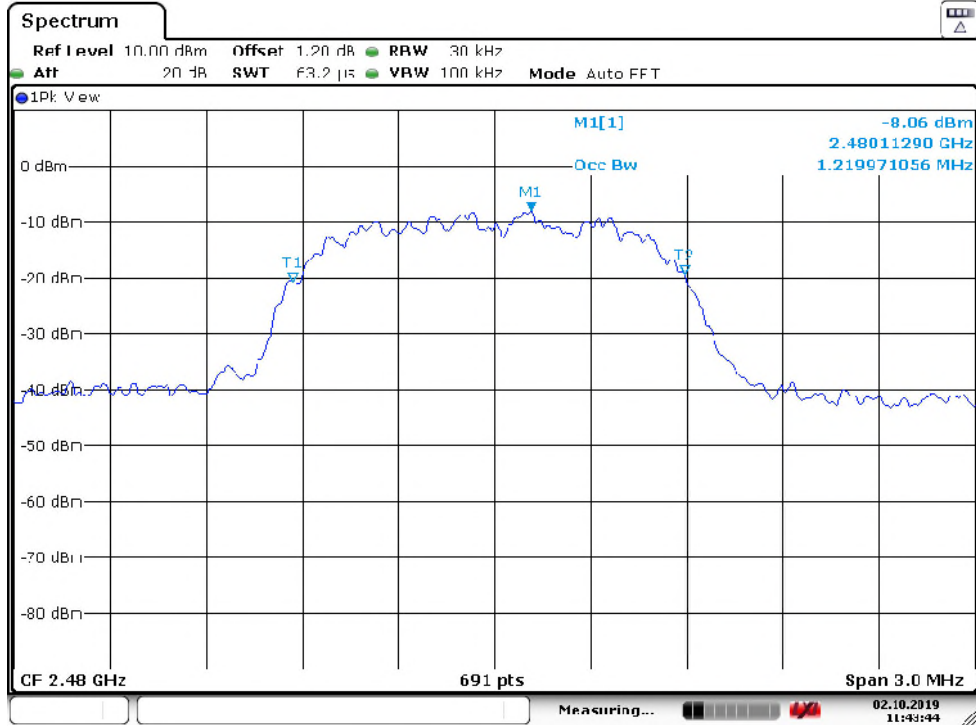

**High Channel**

Date: 2.OCT.2019 11:43:44



### 5.1.5 Conducted spurious emissions and Frequency Band Edge measured in 100kHz Bandwidth

**RESULT:** **Passed**

Test standard : FCC part 15.247(d),  
Basic standard : ANSI C63.10:2013  
Limit : 20dB (below that in the 100kHz bandwidth within the band that contains the highest level of the desired power)  
Kind of test site : Shielded room

#### Test setup

Test Channel : Low/ Middle/ High for Conducted Spurious Emissions  
Low/ High/ Hopping on for Frequency Band Edge  
Operation Mode : A  
Test Lab. : Linkou  
  
Ambient temperature : 22-26°C  
Relative humidity : 50-65%  
Atmospheric pressure : 100-103 kPa

All emissions are more than 20dB below fundamental, details refer to following test plot, and compliance is achieved as well.

Due to the small size of the RF circuit and that there are no inductive components of significant size connected to the antenna port, 9kHz to 30MHz frequency range is not tested based on technical judgment.

## Test Plot of 100kHz Conducted Emissions, 1DH5

### Low Channel

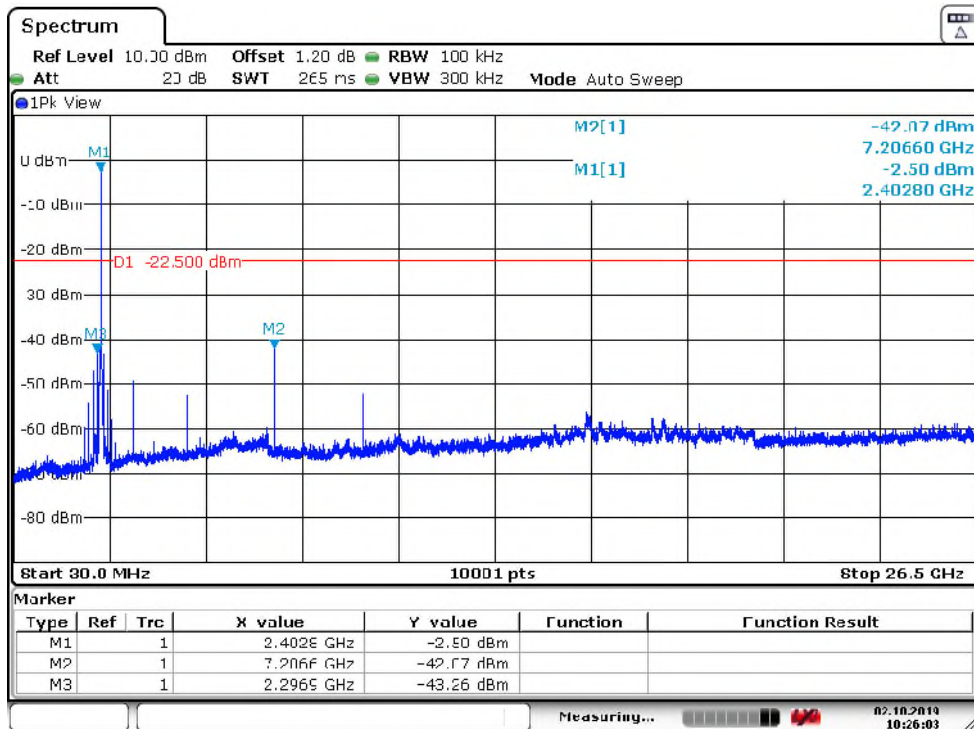

Date: 2.OCT.2019 10:26:04

### Middle Channel

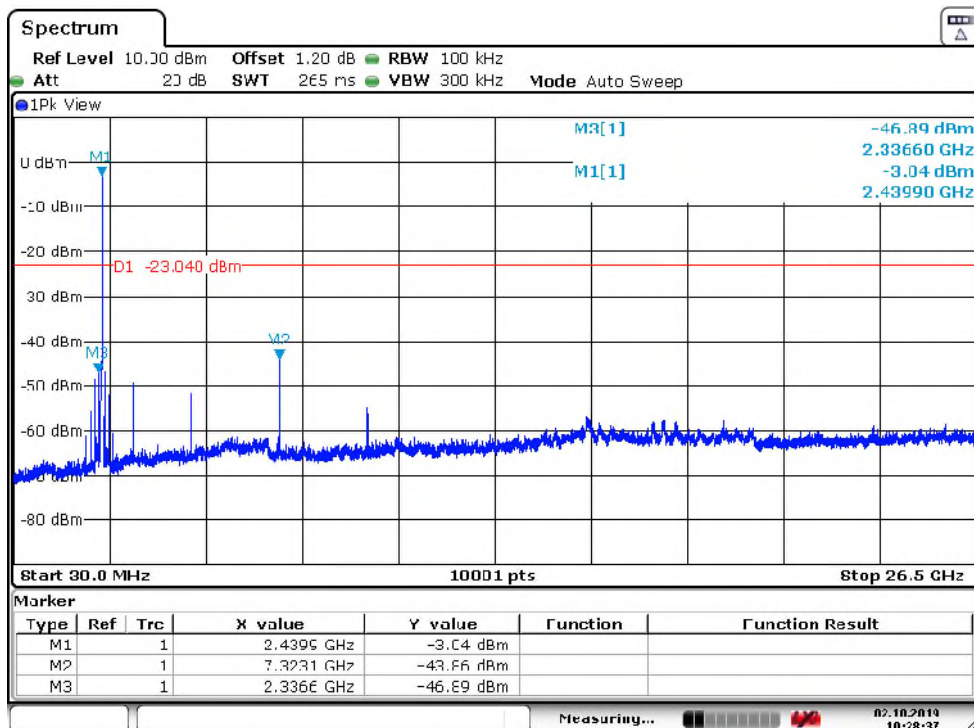

Date: 2.OCT.2019 10:28:38

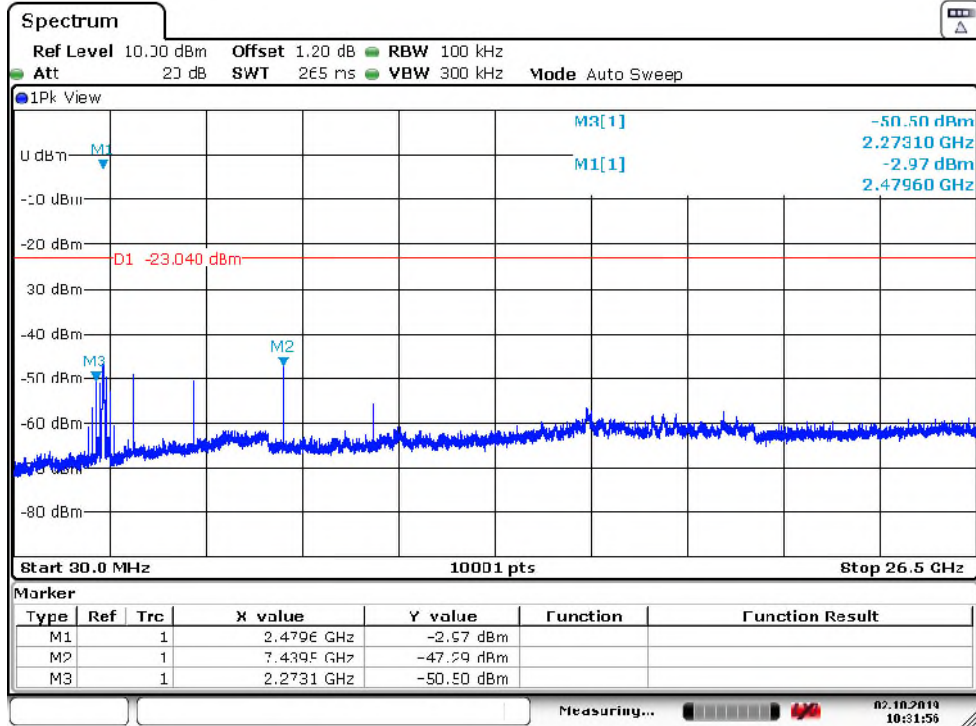
**High Channel**

Date: 2.OCT.2019 10:31:56

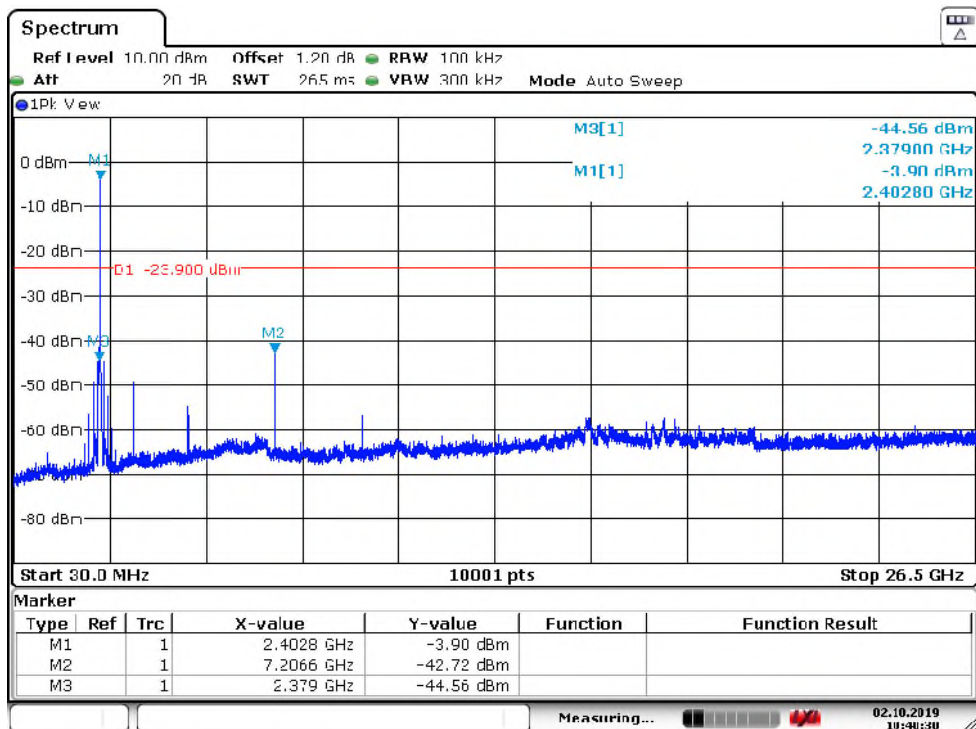
**Test Plot of 100kHz Conducted Emissions, 3DH5**
**Low Channel**

Date: 2.OCT.2019 10:40:31

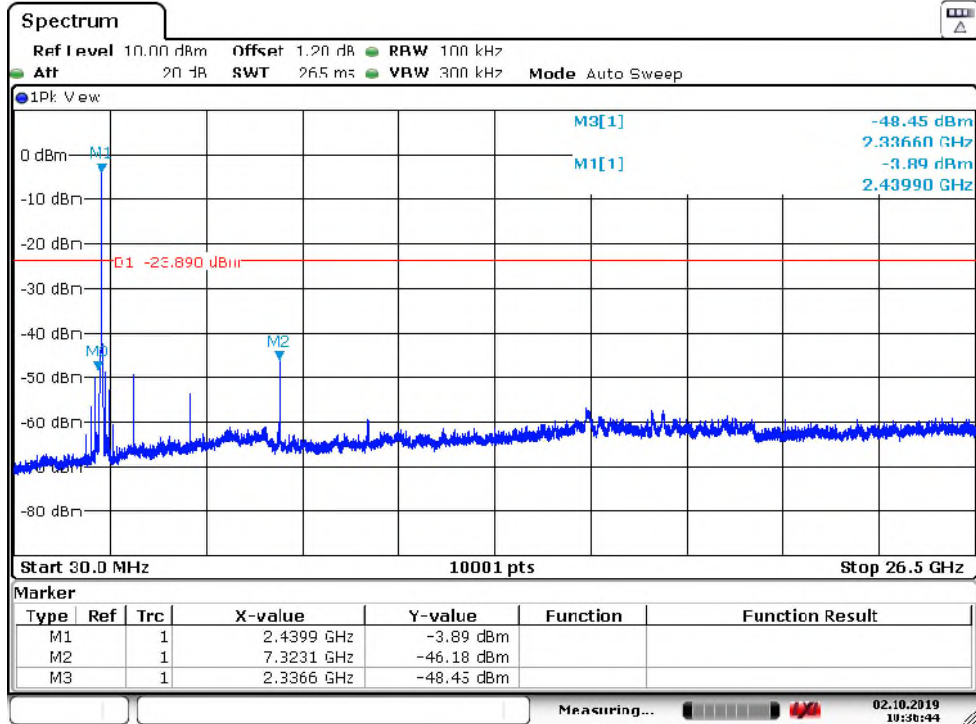
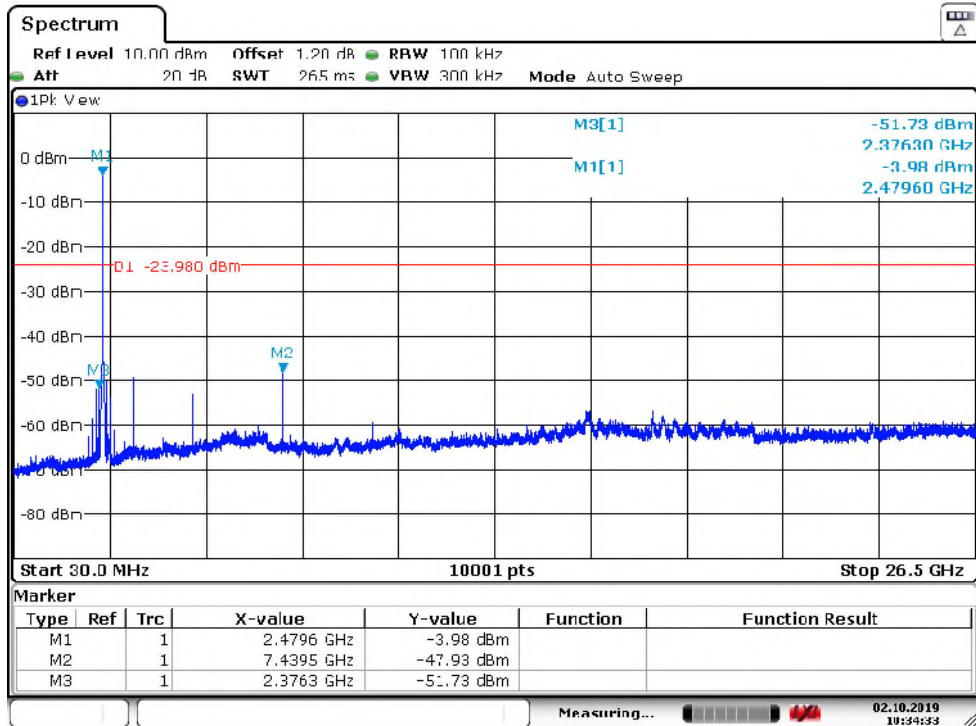
**Middle Channel**

**High Channel**

## Test Plot of 100kHz Bandwidth of Frequency Band Edge, 1DH5

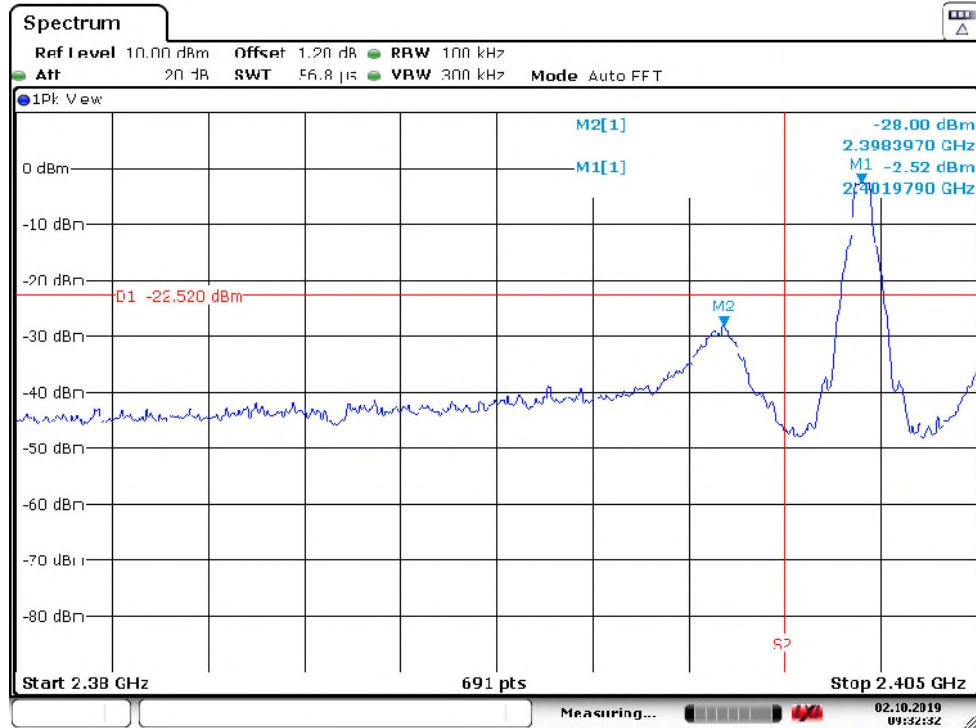
### Low Channel

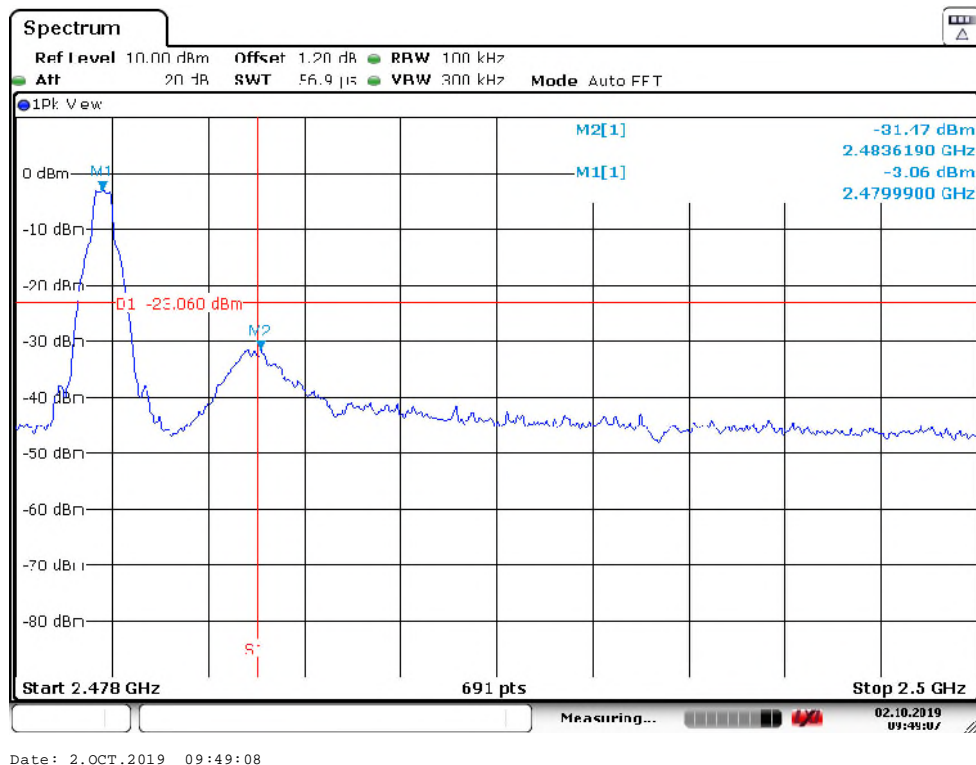

### High Channel





## Test Plot of 100kHz Bandwidth of Frequency Band Edge, 2DH5

### Low Channel

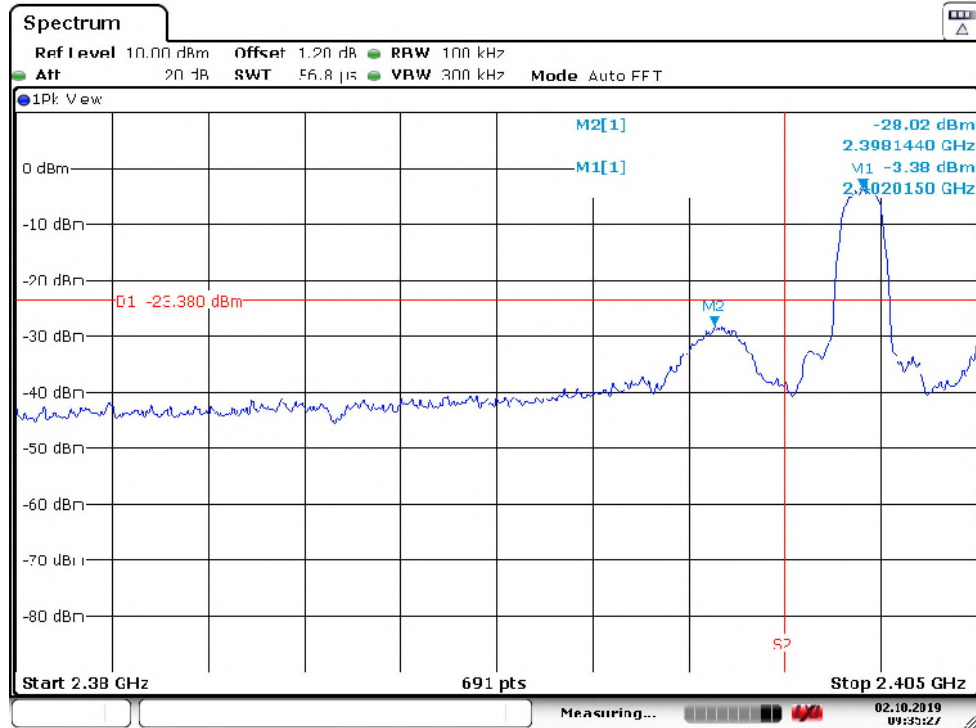

### High Channel

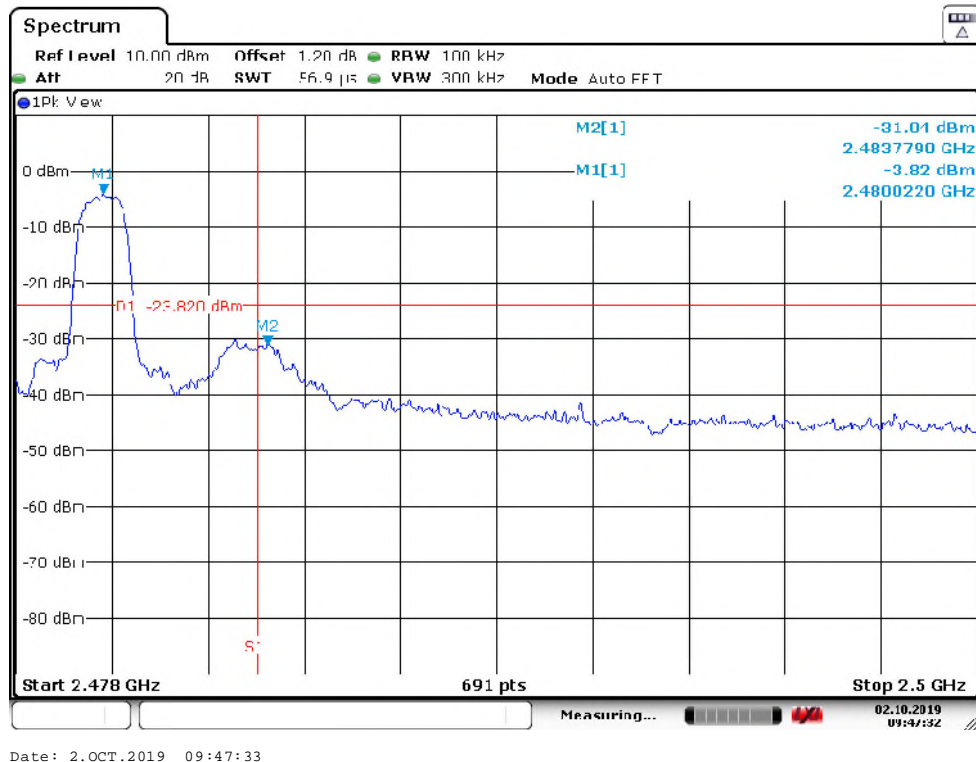

## Test Plot of 100kHz Bandwidth of Frequency Band Edge, 3DH5

### Low Channel

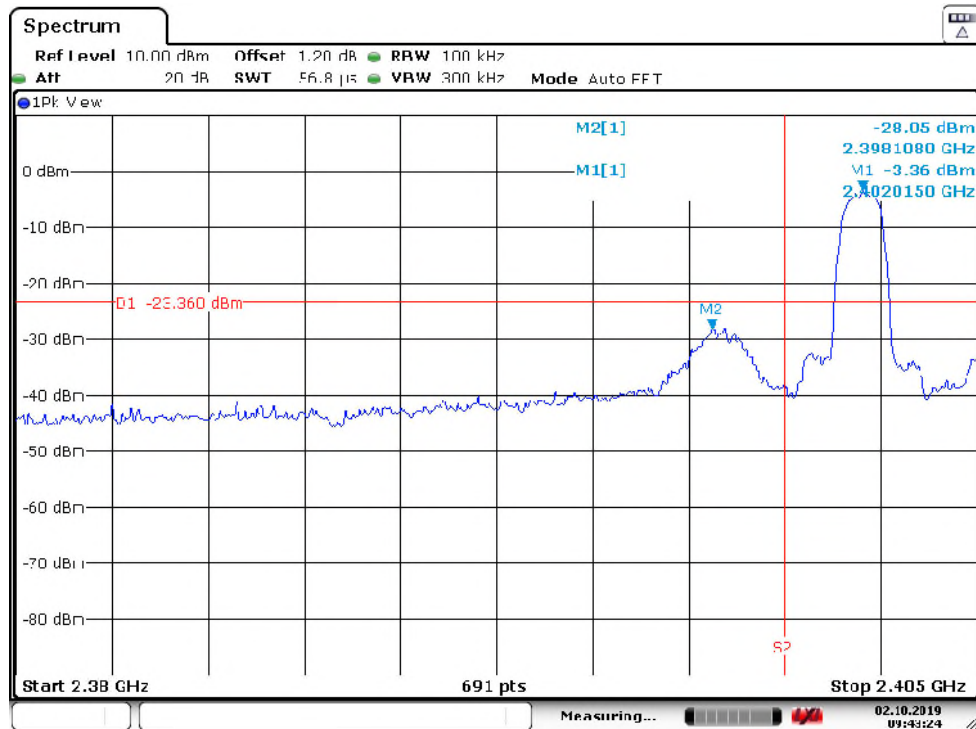

Date: 2.OCT.2019 09:43:25

### High Channel

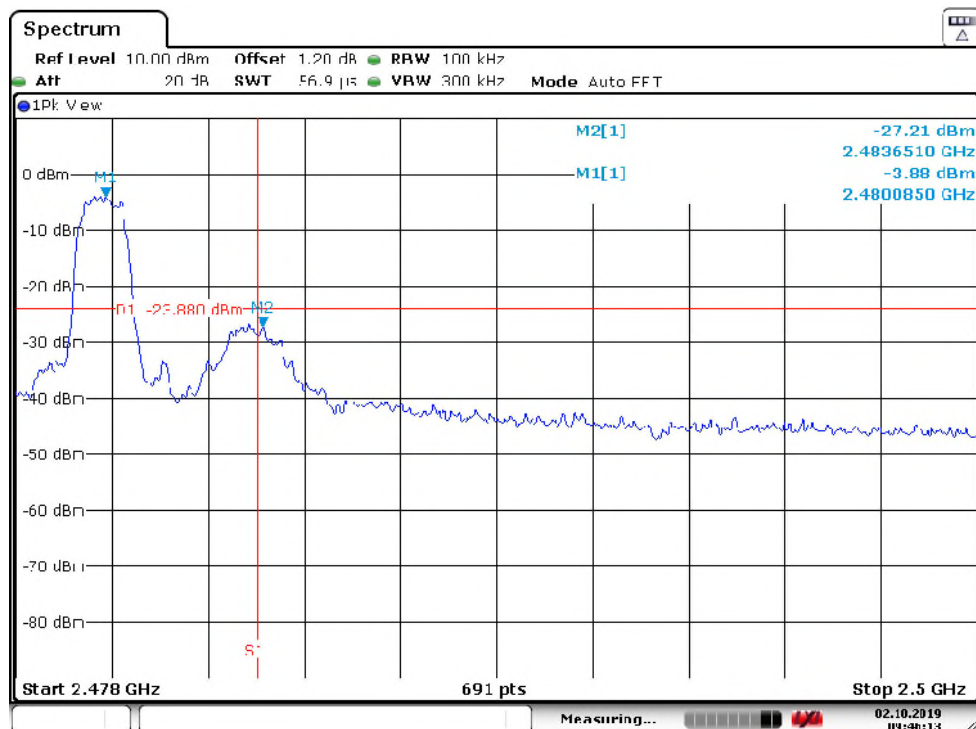

Date: 2.OCT.2019 09:46:13

### 5.1.6 Spurious Emission

**RESULT:****Passed**

Test standard	:	FCC part 15.247(d), FCC 15.205, FCC 15.209 and
Basic standard	:	ANSI C63.10: 2013
Limits	:	Radiated emissions which fall in the restricted bands, as defined in FCC 15.205(a) must comply with the radiated emission limits specified in FCC 15.209(a) Emission radiated outside the restricted and authorized frequency bands must either comply with the radiated emission limits specified for the restricted bands or in FCC15.247(d)
Kind of test site	:	3m Semi-Anechoic Chamber

**Test setup**

Test Channel	:	Low/ Middle/ High
Operation Mode	:	A
Test Lab.	:	Linkou
Ambient temperature	:	22-26°C
Relative humidity	:	50-65%
Atmospheric pressure	:	100-103 kPa

Remark: Testing was carried out within frequency range 9kHz to the tenth harmonic. For details refer to Appendix D. The Radiated Emissions testing was performed in the X, Y and Z axis orientation. The worst-case Axis orientation is recorded in this test report.



### 5.1.7 Frequency Separation

**RESULT:**
**Passed**

Test standard : FCC part 15.247(a)(1)  
 Basic standard : ANSI C63.10:2013  
 Limit :  $\geq 25\text{kHz}$  or  $2/3$  of 20dB bandwidth, whichever is greater  
 Kind of test site : Shielded room

**Test setup**

Test Channel : Hopping On  
 Operation Mode : C  
 Test Lab. : Linkou  
 Ambient temperature : 22-26°C  
 Relative humidity : 50-65%  
 Atmospheric pressure : 100-103 kPa

**Table 20: Test result of Frequency Separation**

Channel	Channel Frequency (MHz)	Measured Channel Separation (MHz)	Limit (kHz)	Result
Record Channel	2441	1	$\geq 25\text{kHz}$ or $2/3$ of 20dB bandwidth	Pass
Record Channel adj 1	2440			
Record Channel adj 2	2442			

## Test Plot of Frequency Separation

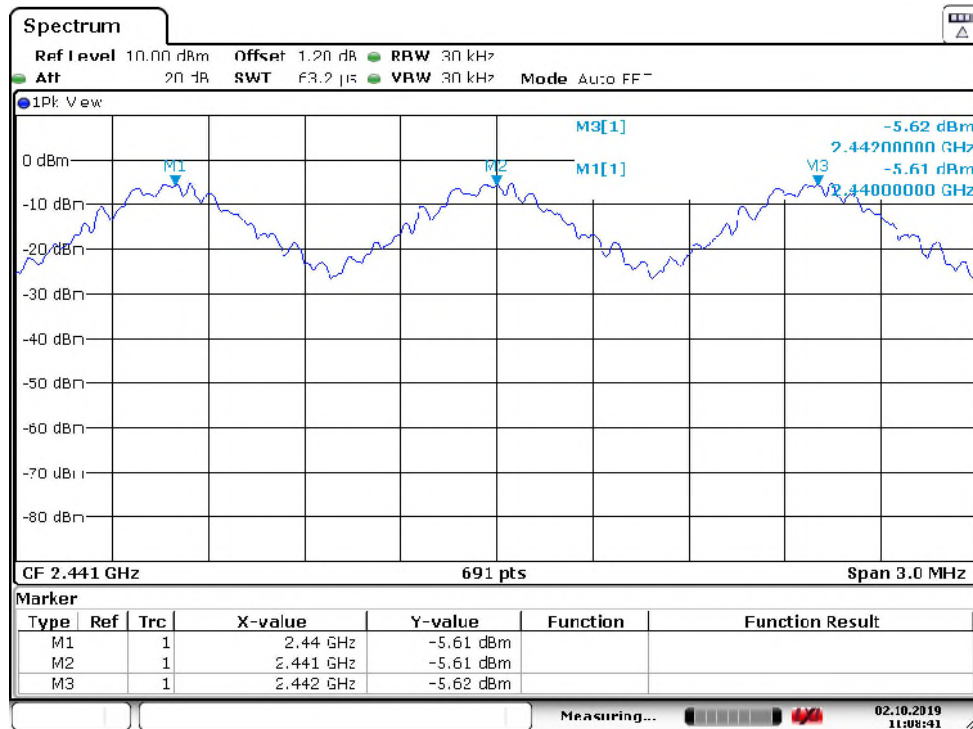
**1DH5**

Date: 2.OCT.2019 11:08:42

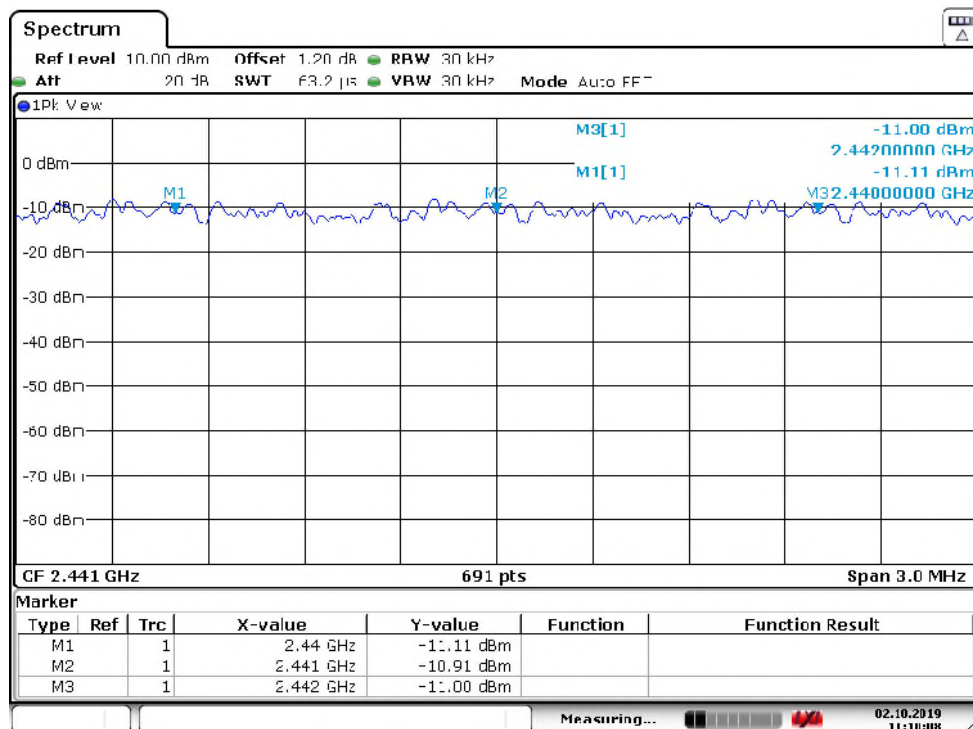
**2DH5**

Date: 2.OCT.2019 11:10:08

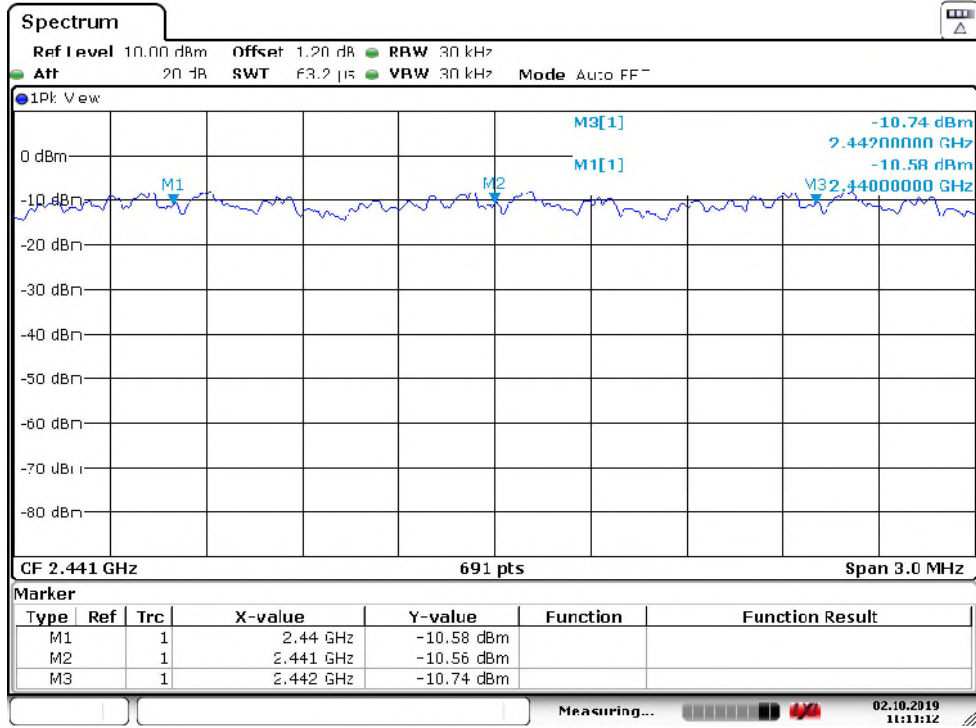
**3DH5**

Date: 2.OCT.2019 11:11:12

### 5.1.8 Number of hopping frequency

**RESULT:**
**Passed**

Test standard : FCC part 15.247(a)(1)(iii)  
 Basic standard : ANSI C63.10:2013  
 Kind of test site : Shielded room

**Test setup**

Test Channel : Hopping On  
 Operation Mode : C  
 Test Lab. : Linkou  
 Ambient temperature : 22-26°C  
 Relative humidity : 50-65%  
 Atmospheric pressure : 100-103 kPa

**Table 21: Test result of Number of hopping frequency**

Frequency Range	Measured Quantity of Hopping Channel	Limit	Result
<u>2400</u> to <u>2483.5</u> MHz	79	≥15	Pass

## Test Plot of Number of hopping frequencies 1DH5

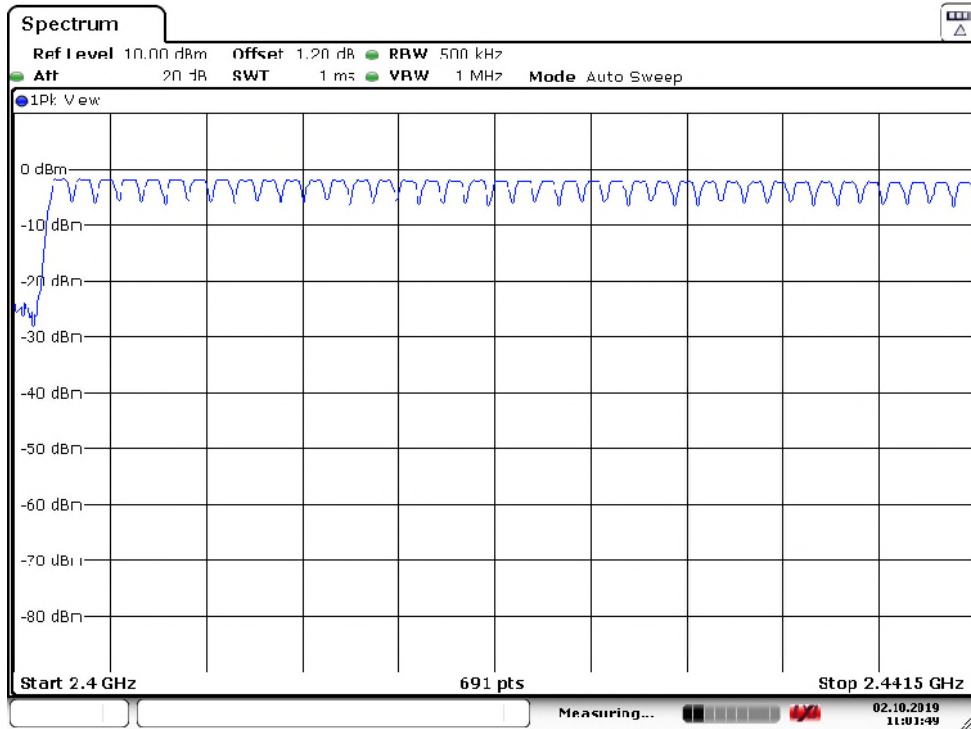

Date: 2.OCT.2019 11:01:49

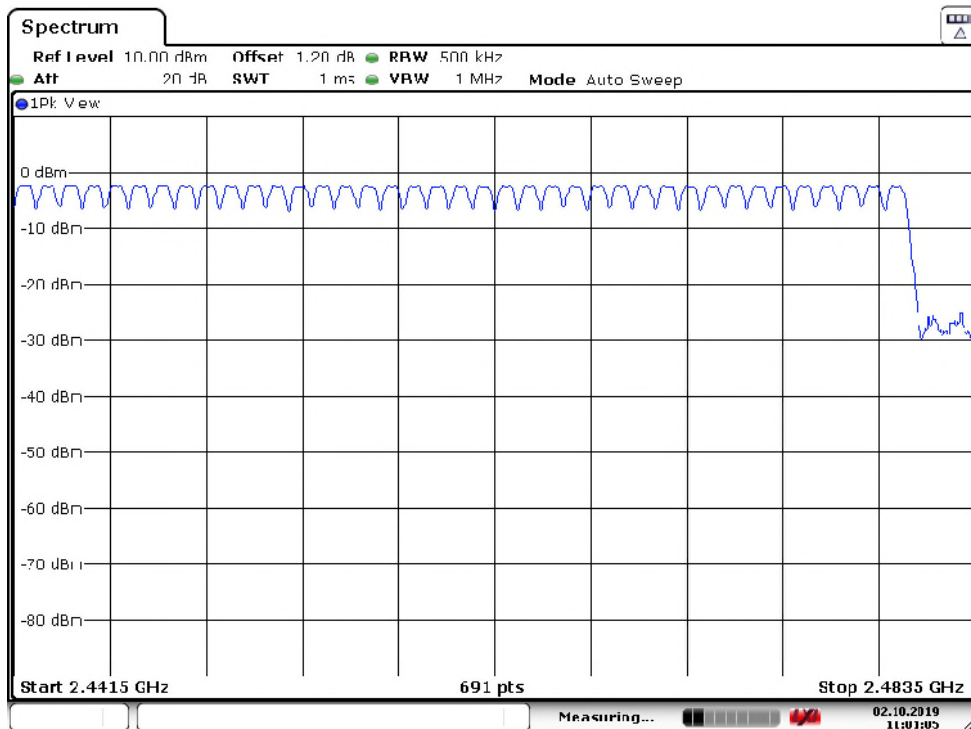

Date: 2.OCT.2019 11:01:06

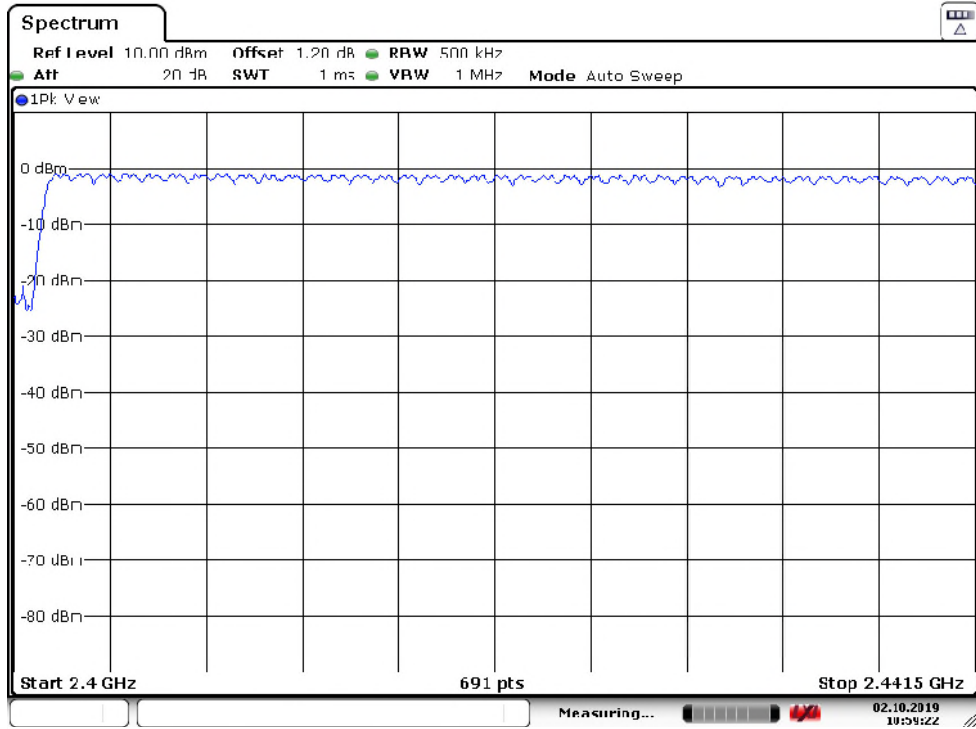
**2DH5**

Date: 2.OCT.2019 10:59:22

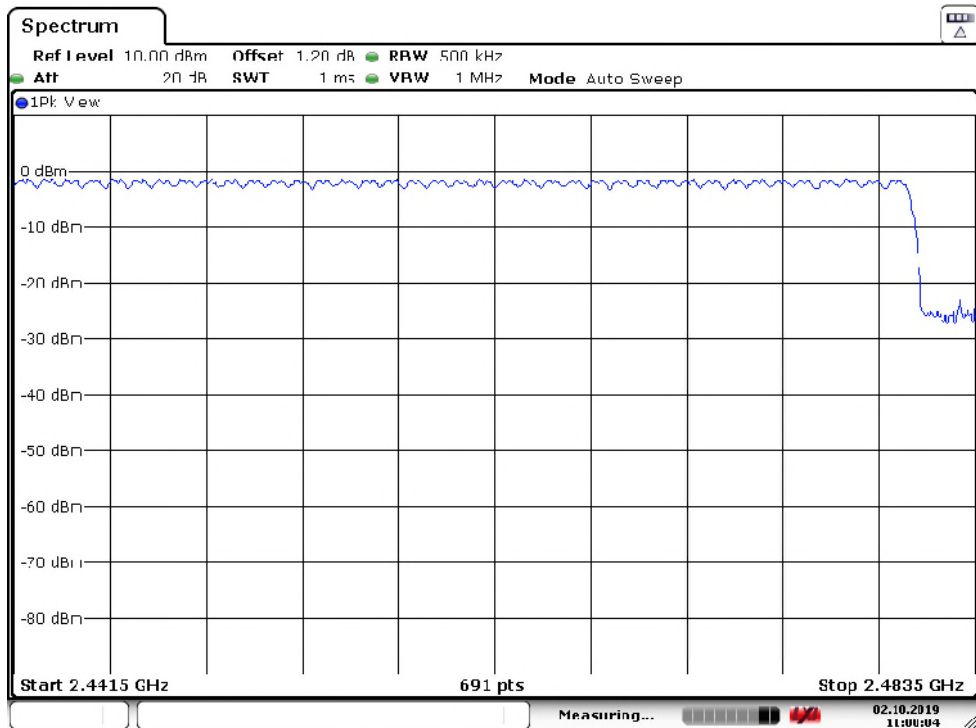

Date: 2.OCT.2019 11:00:05

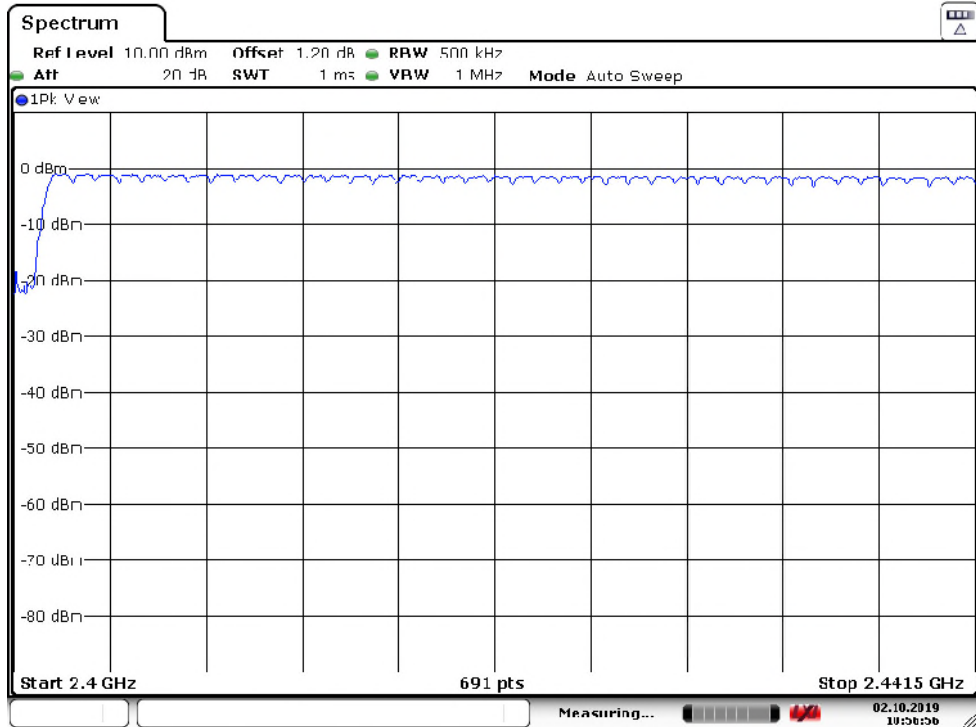
**3DH5**

Date: 2.OCT.2019 10:56:56

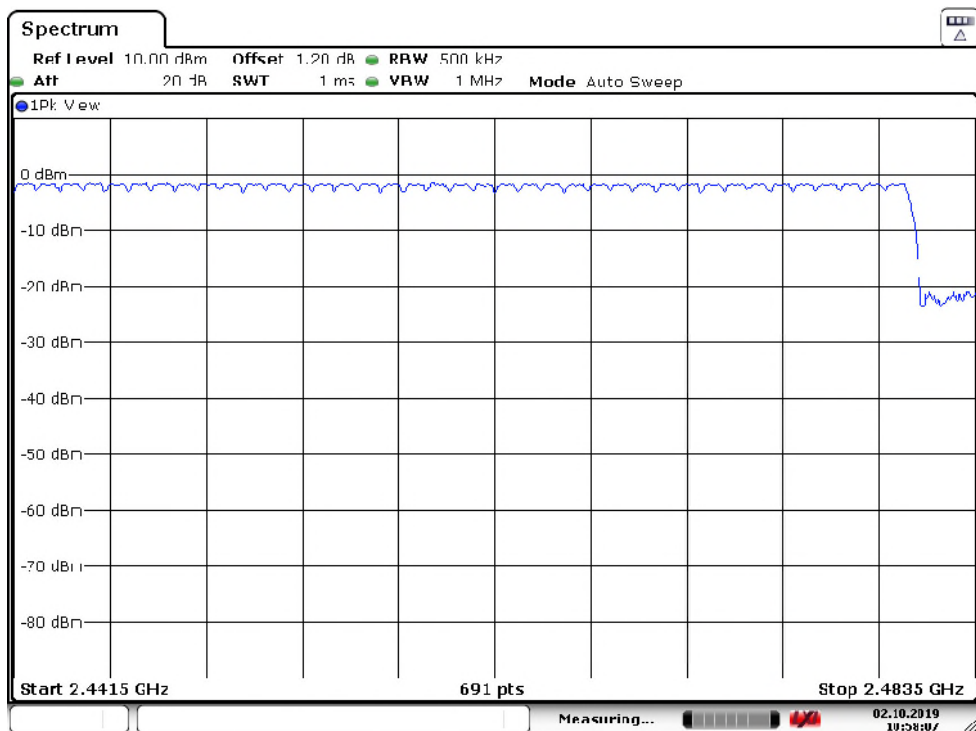

Date: 2.OCT.2019 10:58:07

### 5.1.9 Time of Occupancy

**RESULT:**
**Passed**

Test standard : FCC part 15.247(a)(1)(iii)  
 Basic standard : ANSI C63.10:2013  
 Limits : 0.4s  
 Kind of test site : Shield room

**Test setup**

Test Channel : Low  
 Operation Mode : A  
 Test Lab. : Linkou  
 Ambient temperature : 22-26°C  
 Relative humidity : 50-65%  
 Atmospheric pressure : 100-103 kPa

**Table 22: Test result of Time of Occupancy**

Data Mode	Captured Burst (s)	Dwell time (s)	On+Off time (s)	Limit (s)	Result
1DH5	0.00294	0.32810	0.00359	0.4	Pass
2DH5	0.00292	0.32353	0.00361	0.4	Pass
3DH5	0.00293	0.32464	0.00361	0.4	Pass

Note:

Dwell time = Pulse width x (Hopping rate / Number of channels) x Period

Period = 0.4 (seconds/ channel) x 79 (channel) = 31.6 seconds.

Hopping Rate for 1DH5 = 279 Hz  
 Hopping Rate for 2DH5 = 277 Hz  
 Hopping Rate for 3DH5 = 277 Hz

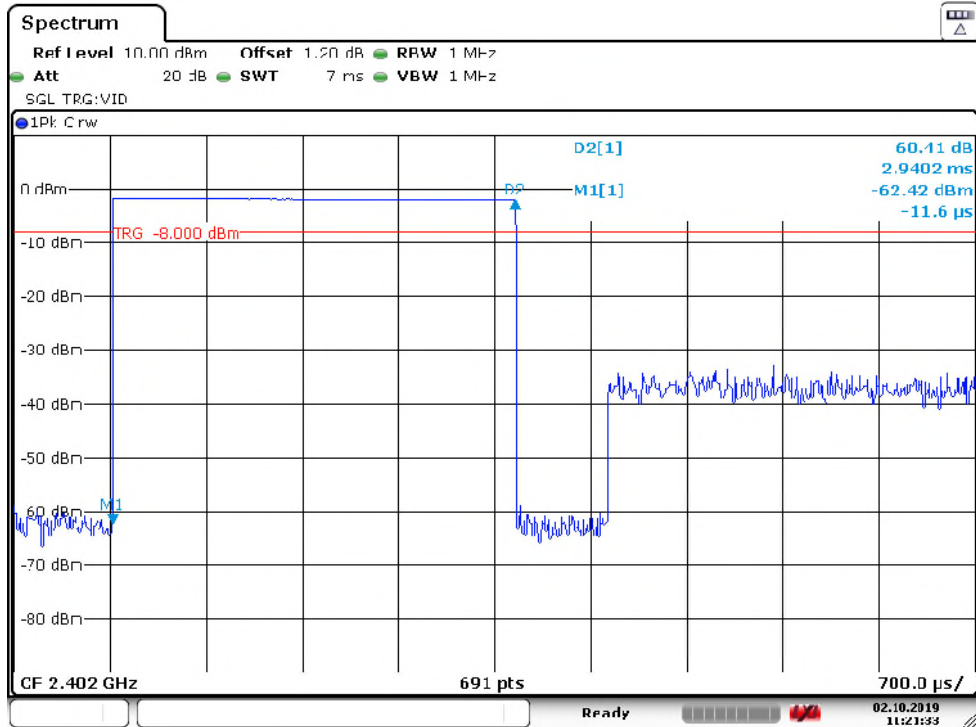

**Test Plot of Time of Occupancy, 1DH5**

Date: 2.OCT.2019 11:21:33

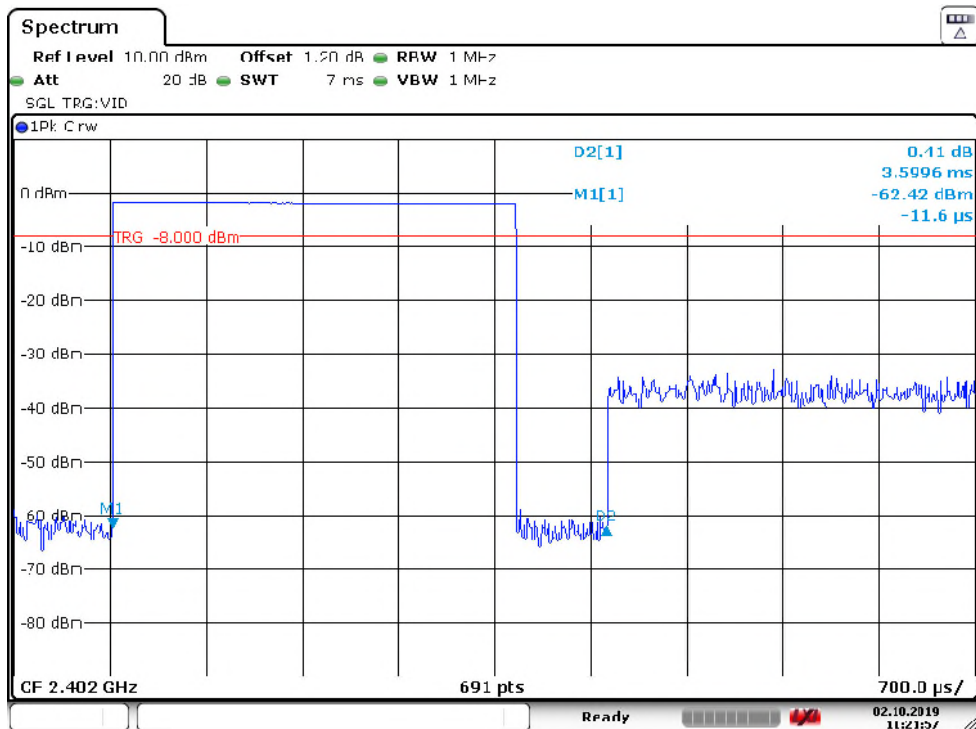

Date: 2.OCT.2019 11:21:57

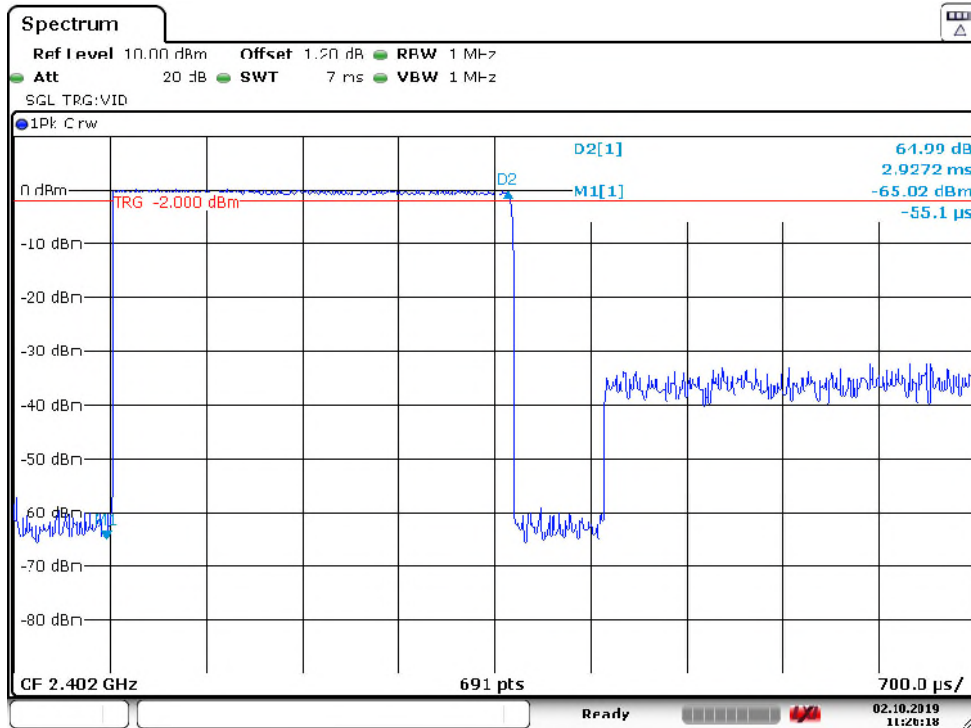
**Test Plot of Time of Occupancy, 2DH5**

Date: 2.OCT.2019 11:26:18

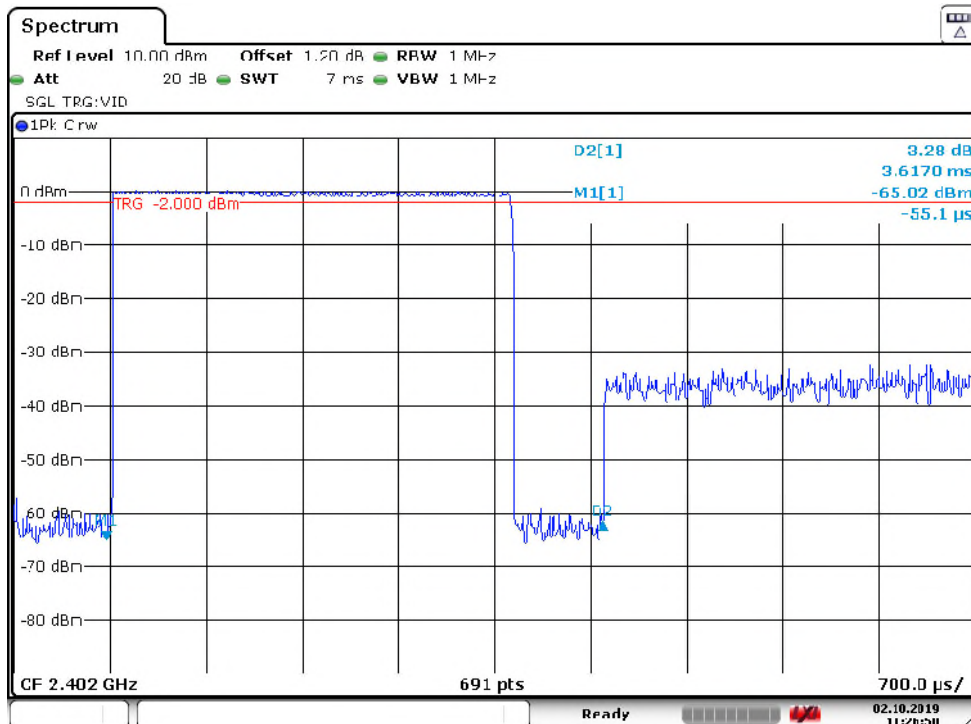

Date: 2.OCT.2019 11:26:50

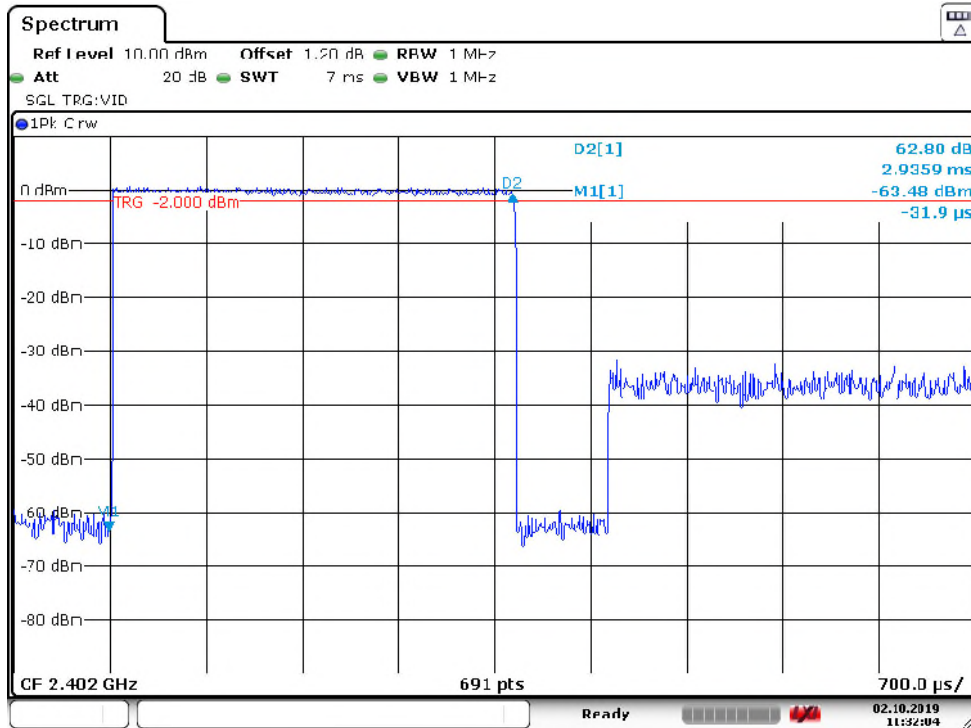
**Test Plot of Time of Occupancy, 3DH5**

Date: 2.OCT.2019 11:32:05

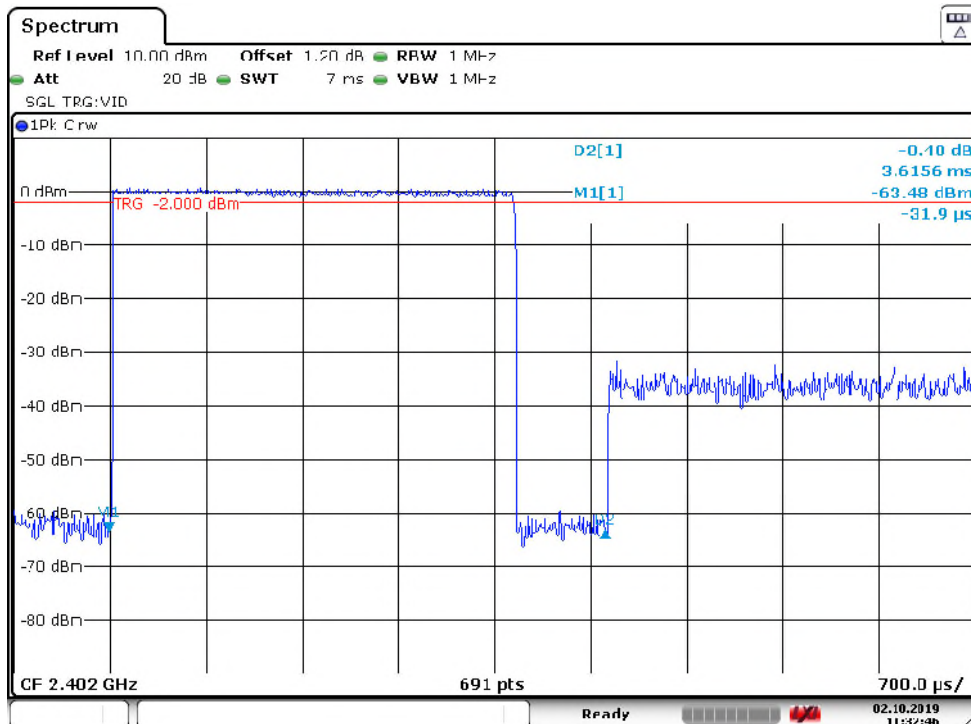

Date: 2.OCT.2019 11:32:46

## Mains Emissions

### 5.1.10 Mains Conducted Emissions

**RESULT:****Passed**

Test standard : FCC Part 15.207  
FCC Part 15.107  
Limits : Mains Conducted emissions as defined in  
above test standards must comply with the  
mains conducted emission limits specified  
Kind of test site : Shielded Room

**Test setup**

Test Channel : Normal link  
Operation mode : Normal link  
Test Lab. : Songshan  
Ambient temperature : 22-26°C  
Relative humidity : 50-65%  
Atmospheric pressure : 100-103 kPa

Remark: For details refer to Appendix D.

## 6. Safety Human exposure

### 6.1 Radio Frequency Exposure Compliance

#### 6.1.1 Electromagnetic Fields

**RESULT:****Passed**

Test standard : FCC KDB Publication 447498 D01

Since maximum peak output power of the transmitter is 0.6808 mW < 10mW, hence the EUT is excluded from SAR evaluation according to FCC KDB publication 447498: Mobile Portable RF Exposure

## 7. Photographs of the Test Set-Up

Photograph 1: Set-up for Spurious Emissions (Front View 1)



Photograph 2: Set-up for Spurious Emissions (Front View 2)

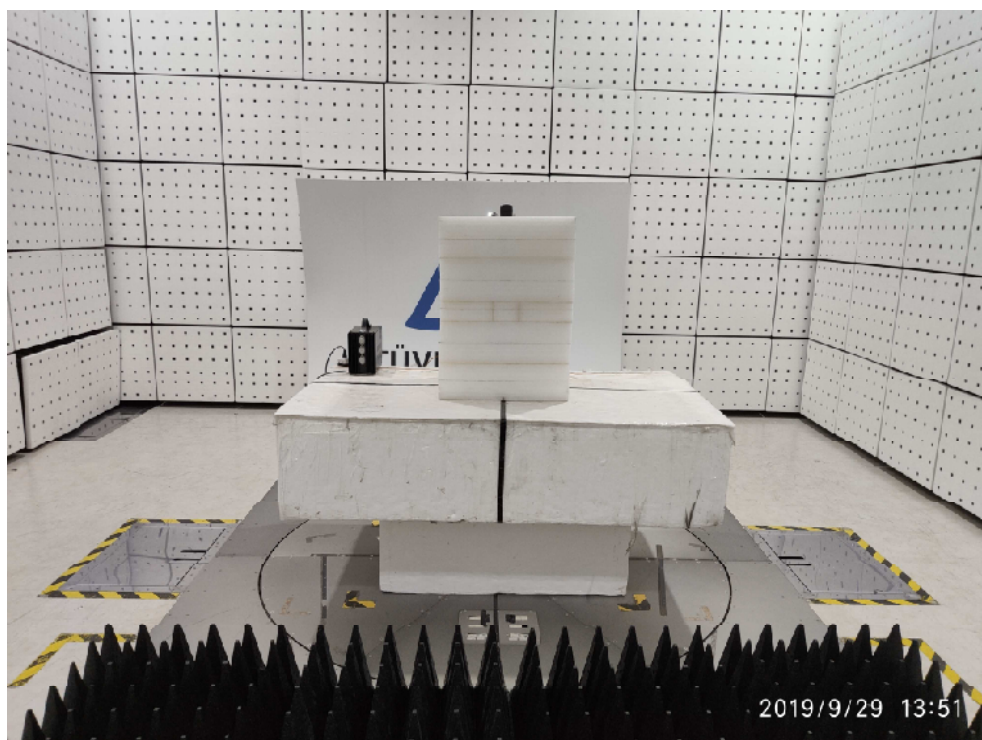



Photograph 3: Set-up for Spurious Emissions (Back View 1)

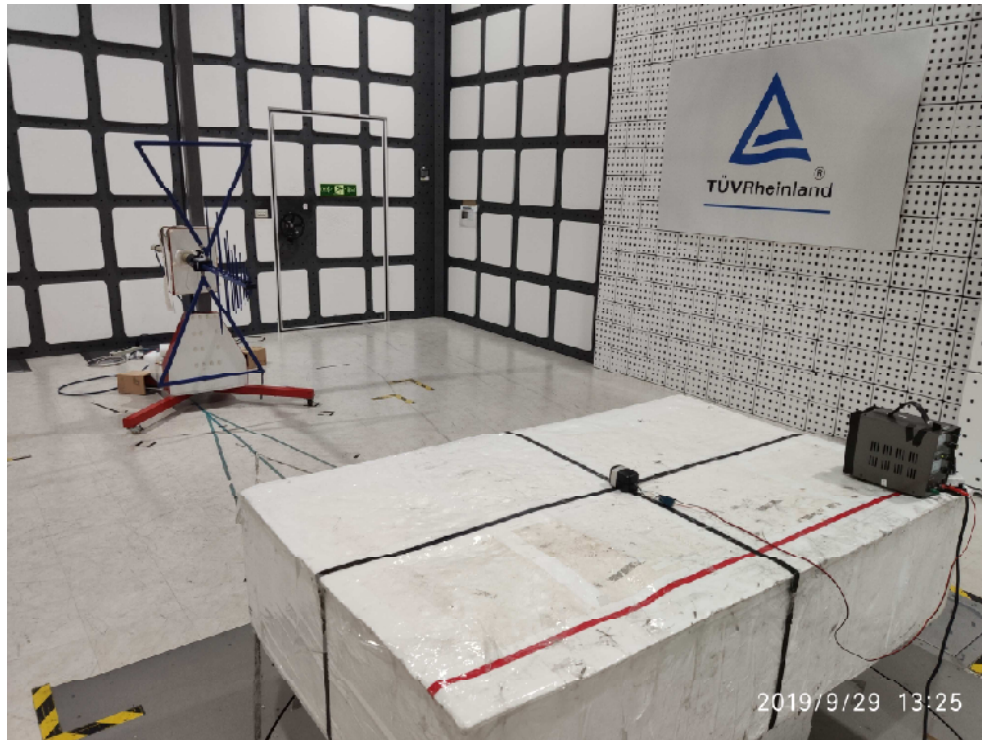

Photograph 4: Set-up for Spurious Emissions (Back View 2)

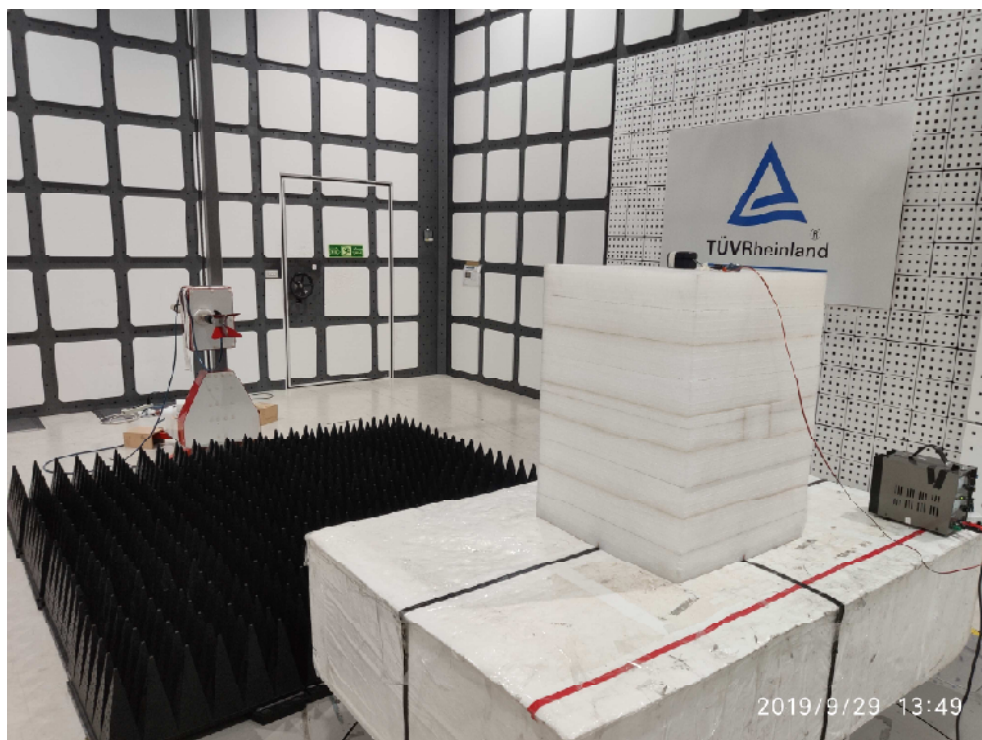

**Photograph 5: Set-up for Conducted testing**

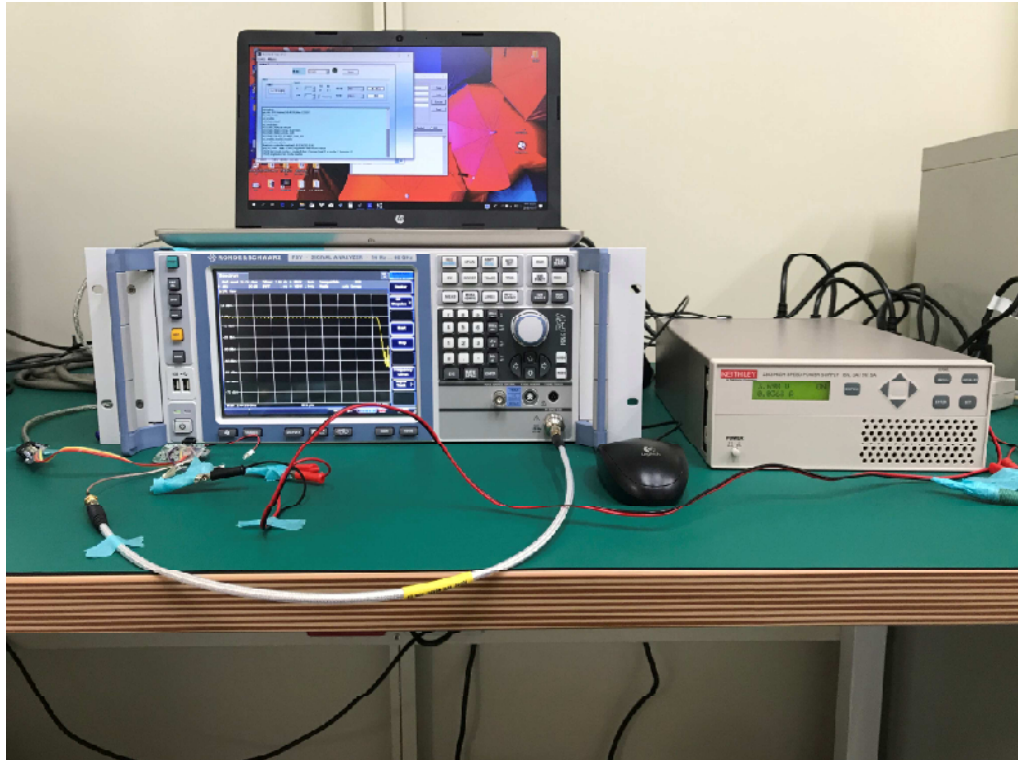

**Photograph 6: Set-up for Mains Conducted testing (Back View)**





**Photograph 7: Set-up for Mains Conducted testing (Front View)**



## 8. List of Tables

Table 1: Applied Standard and Test Levels .....	5
Table 2: List of Test and Measurement Equipment .....	7
Table 3: Emission Measurement Uncertainty.....	8
Table 4: Basic Information of EUT .....	9
Table 5: Technical Specification of EUT .....	9
Table 6: Frequency hopping information.....	10
Table 7: Table for Parameters of Test Software Setting .....	13
Table 8: Test result of Peak Output Power, 1DH5 .....	18
Table 9: Test result of Peak Output Power, 2DH5 .....	18
Table 10: Test result of Peak Output Power, 3DH5 .....	19
Table 11: Test result of Avg Output Power, 1DH5 .....	19
Table 12: Test result of Avg Output Power, 2DH5 .....	19
Table 13: Test result of Avg Output Power, 3DH5 .....	19
Table 14: Test result of 20dB Bandwidth, 1DH5 .....	20
Table 15: Test result of 20dB Bandwidth, 2DH5 .....	20
Table 16: Test result of 20dB Bandwidth, 3DH5 .....	21
Table 17: Test result of 99% Bandwidth, 1DH5 .....	27
Table 18: Test result of 99% Bandwidth, 2DH5 .....	27
Table 19: Test result of 99% Bandwidth, 3DH5 .....	27
Table 20: Test result of Frequency Separation .....	41
Table 21: Test result of Number of hopping frequency .....	44
Table 22: Test result of Time of Occupancy.....	48

## 9. List of Photographs

Photograph 1: Set-up for Spurious Emissions (Front View 1).....	54
Photograph 2: Set-up for Spurious Emissions (Front View 2).....	54
Photograph 3: Set-up for Spurious Emissions (Back View 1) .....	55
Photograph 4: Set-up for Spurious Emissions (Back View 2).....	55
Photograph 5: Set-up for Conducted testing .....	56
Photograph 6: Set-up for Mains Conducted testing (Back View) .....	56
Photograph 7: Set-up for Mains Conducted testing (Front View).....	57