



# FCC REPORT

**Report Reference No.**..... : **TRE1709017304** R/C.....: 49938

**FCC ID**..... : **H79Q38**

**Applicant's name**..... : **Delta Electronics Incorporated**

**Address**..... : 3, Tungyuan Road Chungli Industrial Zone Taoyuan County  
32063,Taiwan

**Manufacturer**..... : Delta Electronics Incorporated

**Address**..... : 3, Tungyuan Road Chungli Industrial Zone Taoyuan County  
32063,Taiwan

**Test item description** ..... : **HD Pocket Projector**

**Trade Mark** ..... : VIVITEK

**Model/Type reference**..... : Q38

**List Model** ..... : Q38-WH, Q38-BK, Q38-RD, Q38PLUS, Q38PLUS-WH,  
Q38PLUS-BK, Q38PLUS-RD

**Standard** ..... : **47 CFR FCC Part 15 Subpart B**

**Date of receipt of test sample**..... : Sept. 21, 2017

**Date of testing**..... : Sept. 21, 2017 - Sept. 26, 2017

**Date of issue**..... : Sept. 26, 2017

**Result**..... : **Pass**

Compiled by  
( position+printed name+signature)..: File administrators Becky Liang

Supervised by  
( position+printed name+signature)..: Project Engineer Jeff Sun

Approved by  
( position+printed name+signature)..: RF Manager Hans Hu

**Testing Laboratory Name** ..... : **Shenzhen Huatongwei International Inspection Co., Ltd.**

**Address**..... : 1/F, Bldg 3, Hongfa Hi-tech Industrial Park, Genyu Road,  
Tianliao, Gongming, Shenzhen, China

**Shenzhen Huatongwei International Inspection Co., Ltd. All rights reserved.**

This publication may be reproduced in whole or in part for non-commercial purposes as long as the Shenzhen Huatongwei International Inspection Co., Ltd. is acknowledged as copyright owner and source of the material. Shenzhen Huatongwei International Inspection Co., Ltd. takes no responsibility for and will not assume liability for damages resulting from the reader's interpretation of the reproduced material due to its placement and context.

*The test report merely corresponds to the test sample.  
It is not permitted to copy extracts of these test result without the written permission of the test laboratory.*

## Contents

<b><u>1.</u></b>	<b><u>TEST STANDARDS AND REPORT VERSION .....</u></b>	<b><u>3</u></b>
1.1.	Test Standards	3
1.2.	Report version	3
<b><u>2.</u></b>	<b><u>TEST DESCRIPTION .....</u></b>	<b><u>4</u></b>
<b><u>3.</u></b>	<b><u>SUMMARY.....</u></b>	<b><u>5</u></b>
3.1.	Client Information	5
3.2.	Product Description	5
3.3.	EUT operation mode	5
3.4.	EUT configuration	5
3.5.	Configuration of Tested System	6
<b><u>4.</u></b>	<b><u>TEST ENVIRONMENT .....</u></b>	<b><u>6</u></b>
4.1.	Address of the test laboratory	6
4.2.	Test Facility	6
4.3.	Equipments Used during the Test	7
4.4.	Environmental conditions	7
4.5.	Statement of the measurement uncertainty	8
<b><u>5.</u></b>	<b><u>TEST CONDITIONS AND RESULTS .....</u></b>	<b><u>9</u></b>
5.1.	Conducted Emissions Test	9
5.2.	Radiated Emissions Test	12
<b><u>6.</u></b>	<b><u>TEST SETUP PHOTOS OF THE EUT .....</u></b>	<b><u>16</u></b>
<b><u>7.</u></b>	<b><u>EXTERNAL AND INTERNAL PHOTOS OF THE EUT .....</u></b>	<b><u>16</u></b>

# 1. Test standards and Report version

## 1.1. Test Standards

The tests were performed according to following standards:

[47 CFR FCC Part 15 Subpart B](#) - Unintentional Radiators

[ANSI C63.4: 2014](#) – American National Standard for Methods of Measurement of Radio-Noise Emissions from Low-Voltage Electrical and Electronic Equipment in the Range of 9 kHz to 40GHz

## 1.2. Report version

Version No.	Date of issue	Description
00	Sept. 26, 2017	Original

## 2. Test Description

Test Item	Section in CFR 47	Result
Conducted Emissions	15.107(a)	Pass
Radiated Emissions	15.109(a)	Pass

Note: The measurement uncertainty is not included in the test result.

### 3. Summary

#### 3.1. Client Information

Applicant:	Delta Electronics Incorporated
Address:	3, Tungyuan Road Chungli Industrial Zone Taoyuan County 32063,Taiwan
Manufacturer:	Delta Electronics Incorporated
Address:	3, Tungyuan Road Chungli Industrial Zone Taoyuan County 32063,Taiwan

#### 3.2. Product Description

Name of EUT:	HD Pocket Projector
Trade Mark:	VIVITEK
Model No.:	Q38
Listed Model(s):	Q38-WH, Q38-BK, Q38-RD, Q38PLUS, Q38PLUS-WH, Q38PLUS-BK, Q38PLUS-RD
Power supply:	7.4Vd.c. from internal battery & 12Vd.c. from Adapter
Adapter information:	Model:ADP-66CR B Input:100~240Va.c.,50/60Hz,2A Output: 12Vd.c., 5.5A max
Hardware version:	2800-AS56P1-06 V56+S905X
Software version:	Android 6.0

#### 3.3. EUT operation mode

The EUT has been tested under communication with PC by USB mode.

#### 3.4. EUT configuration

The following peripheral devices and interface cables were connected during the measurement:

- - supplied by the manufacturer
- - supplied by the lab

○	PC	Manufacturer :	DELL
		Model No. :	OptiPlex 3020 MT
○	Display	Manufacturer :	EIZO
		Model No. :	FS2333
○	Keyboard	Manufacturer :	DELL
		Model No. :	SK8115
○	Mouse	Manufacturer :	DELL
		Model No. :	MS111-T

**Note:**Peripheral devices comply with FCC DOC approval.

### 3.5. Configuration of Tested System

EUT Communicate with PC

## 4. Test Environment

### 4.1. Address of the test laboratory

Laboratory: Shenzhen Huatongwei International Inspection Co., Ltd.

Address: 1/F, Bldg 3, Hongfa Hi-tech Industrial Park, Genyu Road, Tianliao, Gongming, Shenzhen, China

Phone: 86-755-26748019 Fax: 86-755-26748089

### 4.2. Test Facility

The test facility is recognized, certified, or accredited by the following organizations:

#### **CNAS-Lab Code: L1225**

Shenzhen Huatongwei International Inspection Co., Ltd. has been assessed and proved to be in compliance with CNAS-CL01 Accreditation Criteria for Testing and Calibration Laboratories (identical to ISO/IEC 17025: 2005 General Requirements) for the Competence of Testing and Calibration Laboratories.

#### **A2LA-Lab Cert. No. 3902.01**

Shenzhen Huatongwei International Inspection Co., Ltd. EMC Laboratory has been accredited by A2LA for technical competence in the field of electrical testing, and proved to be in compliance with ISO/IEC 17025: 2005 General Requirements for the Competence of Testing and Calibration Laboratories and any additional program requirements in the identified field of testing.

#### **FCC-Registration No.: 762235**

Shenzhen Huatongwei International Inspection Co., Ltd. EMC Laboratory has been registered and fully described in a report filed with the FCC (Federal Communications Commission). The acceptance letter from the FCC is maintained in our files. Registration 762235.

#### **IC-Registration No.: 5377B-1**

Two 3m Alternate Test Site of Shenzhen Huatongwei International Inspection Co., Ltd. has been registered by Certification and Engineering Bureau of Industry Canada for the performance of radiated measurements with Registration No. 5377B-1.

#### **ACA**

Shenzhen Huatongwei International Inspection Co., Ltd. EMC Laboratory can also perform testing for the Australian C-Tick mark as a result of our A2LA accreditation.

### 4.3. Equipments Used during the Test

Conducted Emissions					
Item	Test Equipment	Manufacturer	Model No.	Serial No.	Last Cal
1	EMI Test Receiver	Rohde & Schwarz	ESCI	101247	2016/11/13
2	Artificial Mains	Rohde & Schwarz	NNLK 8121	573	2016/11/13
3	Pulse Limiter	Rohde & Schwarz	ESH3-Z2	101488	2016/11/13
4	Test cable	ENVIROFLEX	3651	1101902	2016/11/13
5	Test Software	Rohde & Schwarz	ES-K1	N/A	N/A

Radiated Emissions					
Item	Test Equipment	Manufacturer	Model No.	Serial No.	Last Cal
1	Ultra-Broadband Antenna	ShwarzBeck	VULB9163	538	2016/11/13
2	EMI Test Receiver	Rohde & Schwarz	ESCI	101247	2016/11/13
3	EMI Test Software	Audix	E3	N/A	N/A
4	Turntable	MATURO	TT2.0	----	N/A
5	Antenna Mast	MATURO	TAM-4.0-P-12	----	N/A
6	EMI Test Software	Rohde & Schwarz	ESK1	N/A	N/A
7	Ultra-Broadband Antenna	Rohde&Schwarz	HL562	100015	2016/11/13
8	Amplifer	ShwarzBeck	BBV 9743	9743-0022	2016/11/13
9	TURNTABLE	ETS	2088	2149	N/A
10	HORN ANTENNA	Rohde&Schwarz	HF906	100039	2016/11/13
11	Test cable	Siva Cables Italy	RG 58A/U	W14.02	2016/11/13

The calibration interval was one year.

### 4.4. Environmental conditions

During the measurement the environmental conditions were within the listed ranges:

Temperature:	15~35°C
Relative Humidity:	30~60 %
Air Pressure:	950~1050mba

#### 4.5. Statement of the measurement uncertainty

The data and results referenced in this document are true and accurate. The reader is cautioned that there may be errors within the calibration limits of the equipment and facilities. The measurement uncertainty was calculated for all measurements listed in this test report acc. to CISPR 16 - 4 „Specification for radio disturbance and immunity measuring apparatus and methods – Part 4: Uncertainty in EMC Measurements“ and is documented in the Shenzhen Huatongwei International Inspection Co., Ltd quality system acc. to DIN EN ISO/IEC 17025. Furthermore, component and process variability of devices similar to that tested may result in additional deviation. The manufacturer has the sole responsibility of continued compliance of the device.

Hereafter the best measurement capability for Shenzhen Huatongwei laboratory is reported:

Test	Range	Measurement Uncertainty	Notes
Radiated Emission	30~1000MHz	4.24 dB	(1)
Radiated Emission	1~18GHz	5.16 dB	(1)
Radiated Emission	18-40GHz	5.54 dB	(1)
Conducted Disturbance	0.15~30MHz	3.39 dB	(1)

(1) This uncertainty represents an expanded uncertainty expressed at approximately the 95% confidence level using a coverage factor of  $k=2$ .



## 5. Test Conditions and Results

### 5.1. Conducted Emissions Test

#### LIMIT

FCC CFR Title 47 Part 15 Subpart B Section 15.107:

Frequency range (MHz)	Limit (dBuV)	
	Quasi-peak	Average
0.15-0.5	66 to 56*	56 to 46*
0.5-5	56	46
5-30	60	50

\* Decreases with the logarithm of the frequency.

#### TEST CONFIGURATION

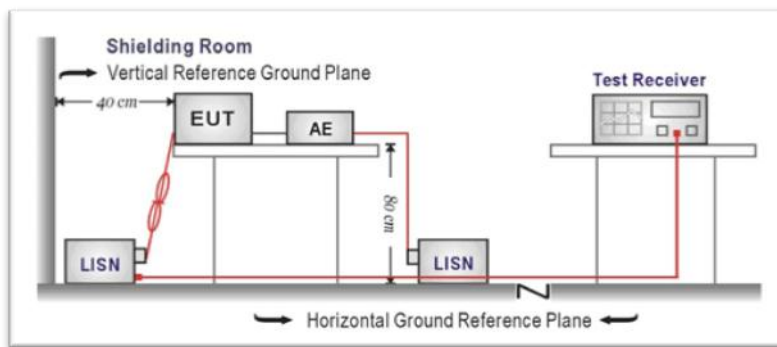

#### TEST PROCEDURE

1. The EUT was setup according to ANSI C63.10:2013 for compliance to FCC 47CFR 15.247 requirements.
2. The EUT was placed on a plat form of nominal size, 1 m by 1.5 m, raised 10 cm above the conducting ground plane. The vertical conducting plane was located 40 cm to the rear of the EUT. All other surfaces of EUT were at least 10 cm from any other grounded conducting surface.
3. The EUT and simulators are connected to the main power through a line impedance stabilization network (LISN). The LISN provides a 50ohm / 50uH coupling impedance for the measuring equipment.
4. The peripheral devices are also connected to the main power through a LISN. (Please refer to the block diagram of the test setup and photographs)
5. Each current-carrying conductor of the EUT power cord, except the ground (safety) conductor, was individually connected through a LISN to the input power source.
6. The excess length of the power cord between the EUT and the LISN receptacle were folded back and forth at the center of the lead to form a bundle not exceeding 40 cm in length.
7. Conducted emissions were investigated over the frequency range from 0.15MHz to 30MHz using a receiver bandwidth of 9 kHz.
8. During the above scans, the emissions were maximized by cable manipulation.

#### TEST MODE:

Please refer to the clause 3.3

#### TEST RESULTS

**Passed**       **Not Applicable**

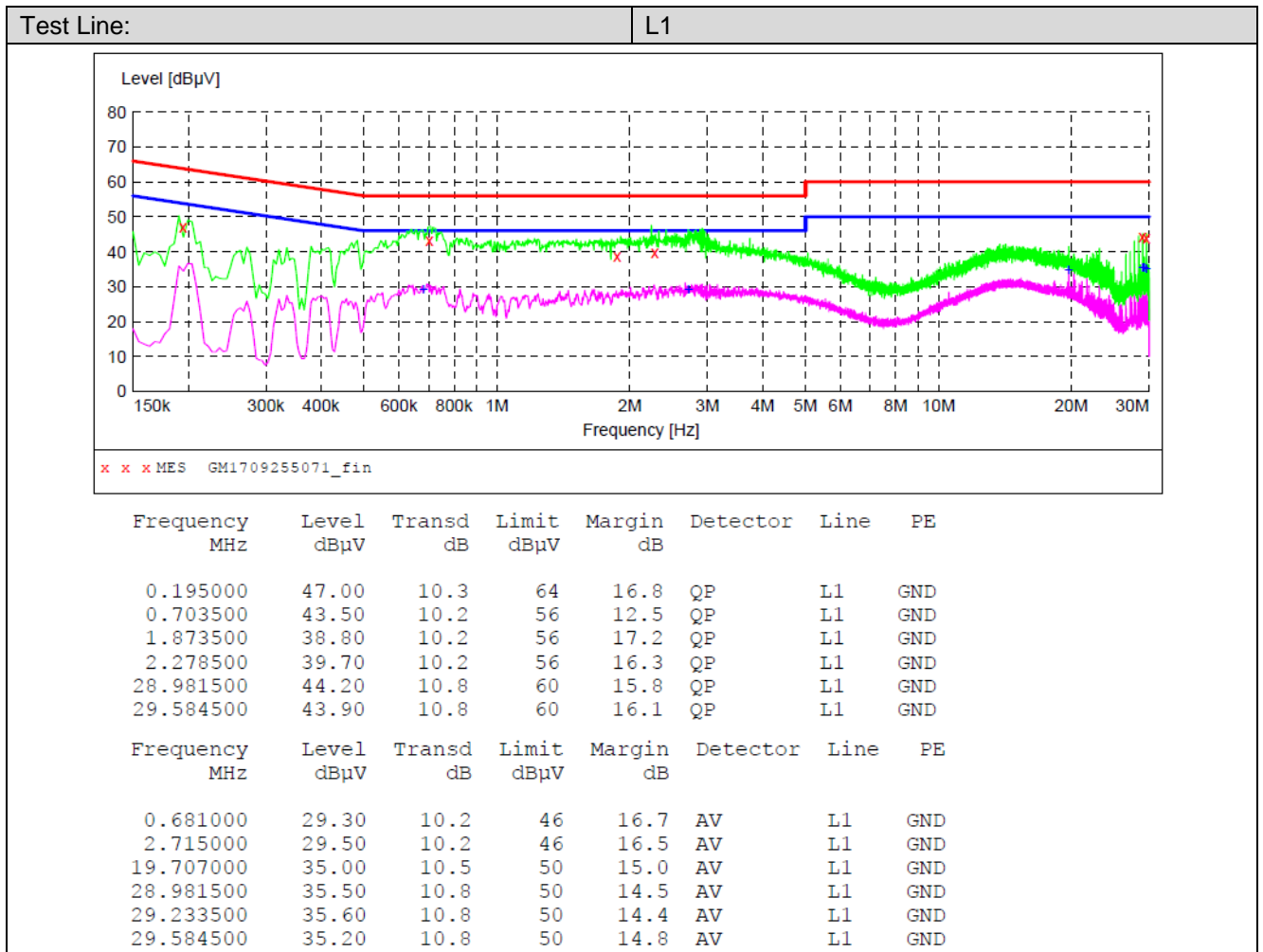

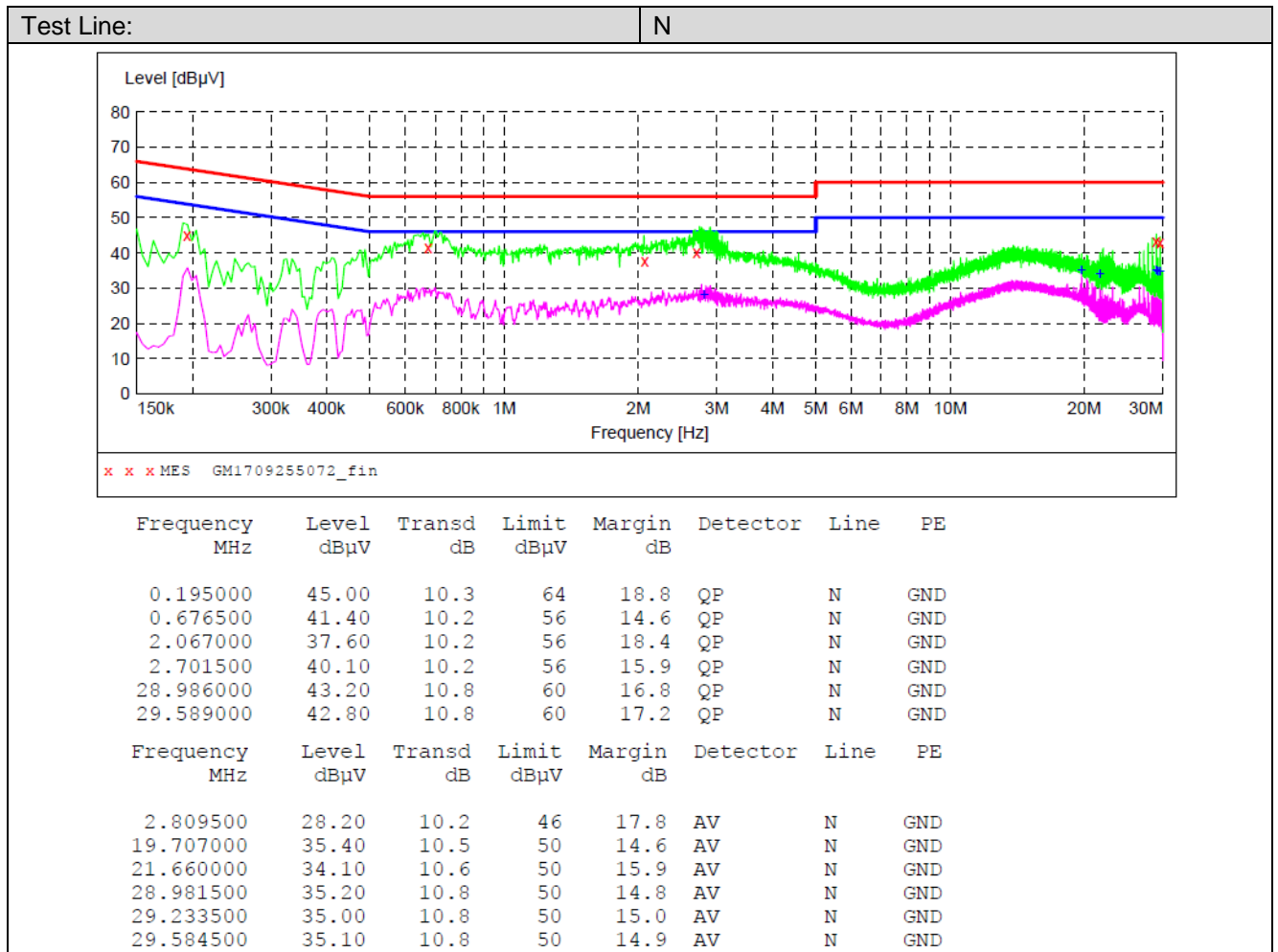

## 5.2. Radiated Emissions Test

### LIMIT

#### FCC CFR Title 47 Part 15 Subpart C Section 15.209

Frequency	Limit (dBuV/m @3m)	Value
30MHz-88MHz	40.00	Quasi-peak
88MHz-216MHz	43.50	Quasi-peak
216MHz-960MHz	46.00	Quasi-peak
960MHz-1GHz	54.00	Quasi-peak
Above 1GHz	54.00	Average
	74.00	Peak

### TEST CONFIGURATION

#### ➤ 30MHz ~ 1GHz

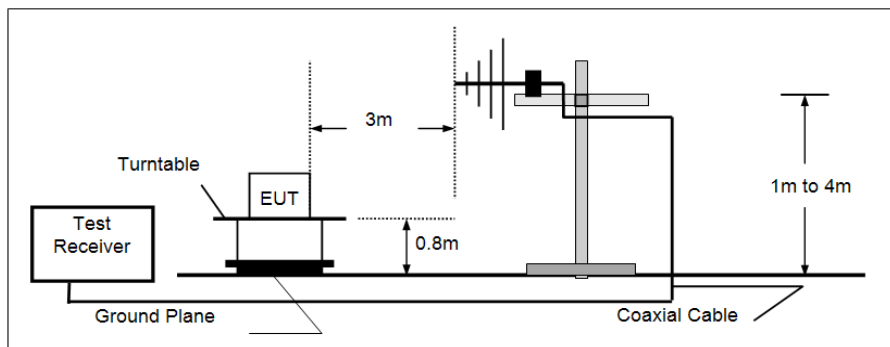

#### ➤ Above 1GHz

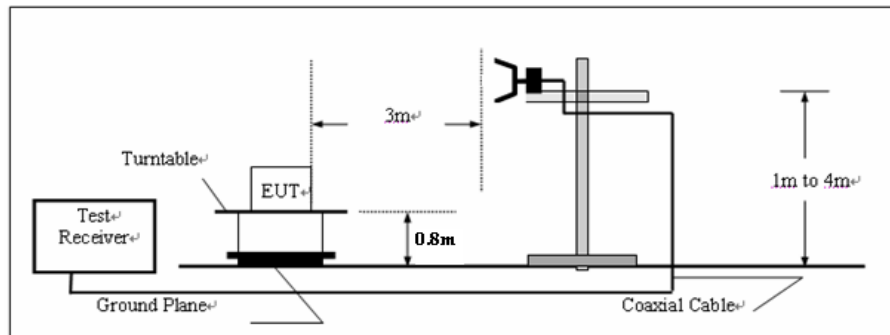

### TEST PROCEDURE

1. The EUT was tested according to ANSI C63.4:2014.
2. The EUT is placed on a turn table which is 0.8 meter above ground. The turn table is rotated 360 degrees to determine the position of the maximum emission level.
3. The EUT was positioned such that the distance from antenna to the EUT was 3 meters.
4. The antenna is scanned from 1 meter to 4 meters to find out the maximum emission level. This is repeated for both horizontal and vertical polarization of the antenna.
5. The tested frequency range 30MHz to 25GHz.
6. Use the following spectrum analyzer settings
  - (1) Span shall wide enough to fully capture the emission being measured;
  - (2) Below 1GHz, RBW=120KHz, VBW=300KHz, Sweep=auto, Detector function=peak, Trace=max hold;  
*If the emission level of the EUT measured by the peak detector is 3 dB lower than the applicable limit, the peak emission level will be reported. Otherwise, the emission measurement will be repeated using the quasi-peak detector and reported.*
  - (3) Above 1GHz, RBW=1MHz, VBW=3MHz

**TEST MODE:**

Please refer to the clause 3.3

**TEST RESULTS**

**Passed**       **Not Applicable**

Note: *Final Level = Receiver Read level + Antenna Factor + Cable Loss – Preamplifier Factor*

Polarization: Horizontal

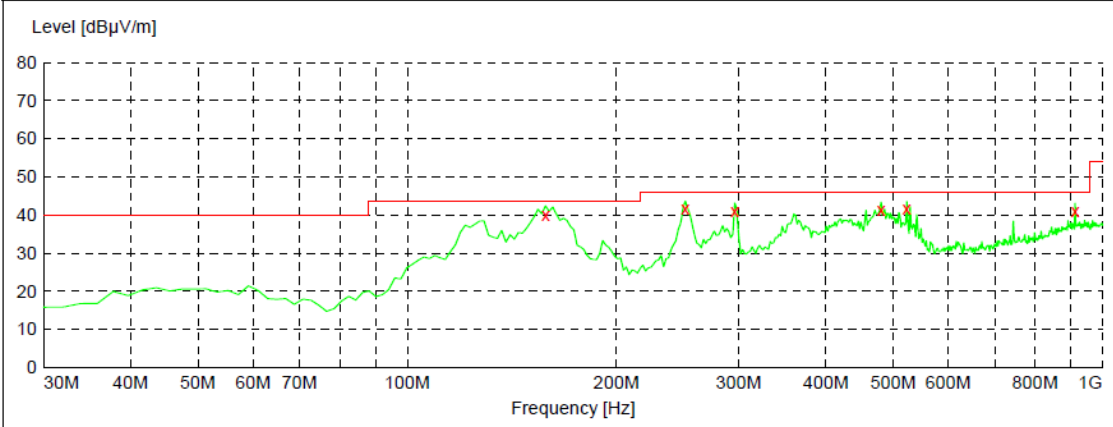

x x x MES GM1709256095\_red

Frequency MHz	Level dBuV/m	Transd dB	Limit dBuV/m	Margin dB	Det.	Height cm	Azimuth deg	Polarization
158.040000	40.40	-13.5	43.5	3.1	QP	100.0	153.00	HORIZONTAL
251.160000	41.70	-8.4	46.0	4.3	QP	100.0	275.00	HORIZONTAL
295.780000	41.10	-7.3	46.0	4.9	QP	100.0	247.00	HORIZONTAL
480.080000	41.40	-2.5	46.0	4.6	QP	100.0	195.00	HORIZONTAL
522.760000	41.50	-1.3	46.0	4.5	QP	100.0	344.00	HORIZONTAL
912.700000	41.10	6.9	46.0	4.9	QP	100.0	195.00	HORIZONTAL

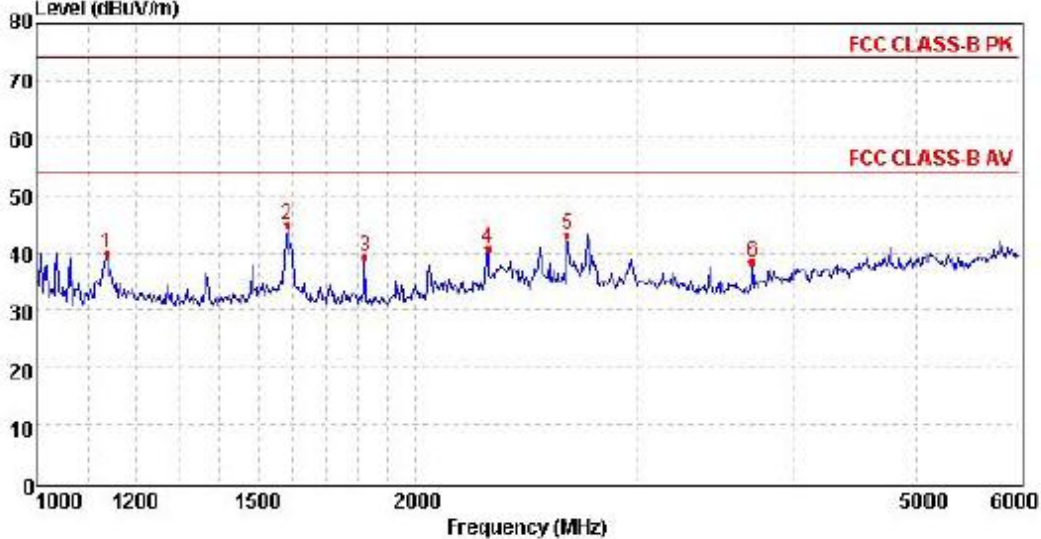

Mark	Frequency MHz	Reading dBuV/m	Antenna dB	Cable dB	Preamp dB	Level dBuV/m	Limit dBuV/m	Over limit	Remark
1	1138.63	46.06	25.82	4.52	36.60	39.82	74.00	-34.18	Peak
2	1581.22	51.13	25.06	5.52	36.70	45.01	74.00	-28.99	Peak
3	1823.43	44.90	25.38	6.00	37.16	39.12	74.00	-34.88	Peak
4	2281.32	43.75	27.99	6.57	37.57	40.74	74.00	-33.26	Peak
5	2637.54	46.04	27.91	7.00	37.94	43.01	74.00	-30.99	Peak
6	3700.26	38.78	29.30	8.39	38.25	38.22	74.00	-35.78	Peak

Note: The frequency range 6GHz to 25GHz no emission found, only report worse case.

Polarization: Vertical

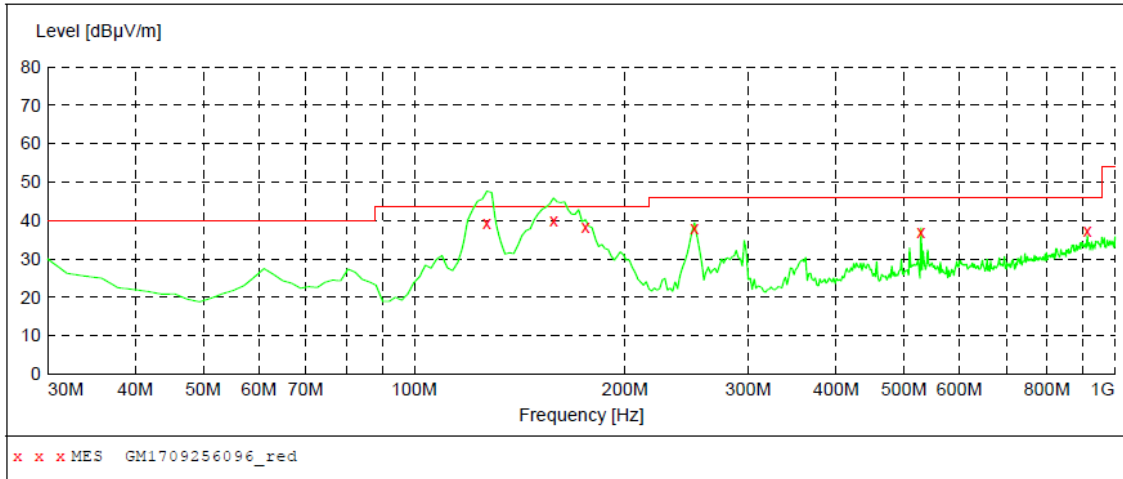

Frequency MHz	Level dBuV/m	Transd dB	Limit dBuV/m	Margin dB	Det.	Height cm	Azimuth deg	Polarization
127.000000	38.80	-13.1	43.5	4.7	QP	100.0	227.00	VERTICAL
158.040000	40.00	-13.5	43.5	3.5	QP	100.0	333.00	VERTICAL
175.500000	39.40	-12.7	43.5	4.1	QP	100.0	321.00	VERTICAL
251.160000	39.60	-8.4	46.0	6.4	QP	100.0	92.00	VERTICAL
528.580000	38.30	-1.2	46.0	7.7	QP	100.0	199.00	VERTICAL
912.700000	36.30	6.9	46.0	9.7	QP	100.0	40.00	VERTICAL

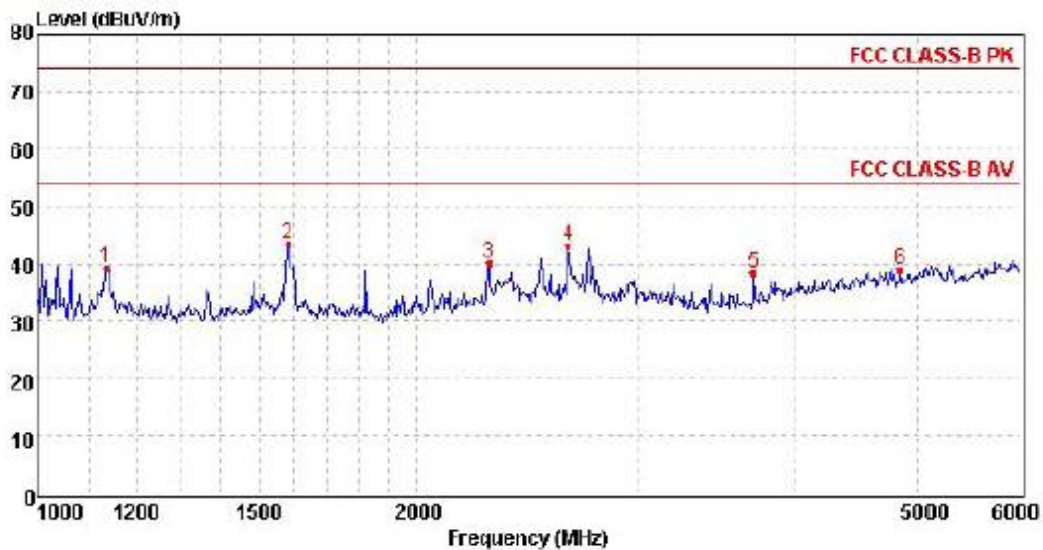

Mark	Frequency MHz	Reading dBuV/m	Antenna dB	Cable dB	Preamp dB	Level dBuV/m	Limit dBuV/m	Over limit	Remark
1	1135.73	45.47	25.79	4.52	36.60	39.18	74.00	-34.82	Peak
2	1581.22	49.68	25.06	5.52	36.70	43.56	74.00	-30.44	Peak
3	2281.32	43.18	27.99	6.57	37.57	40.17	74.00	-33.83	Peak
4	2637.54	46.04	27.91	7.00	37.94	43.01	74.00	-30.99	Peak
5	3700.26	38.78	29.30	8.39	38.25	38.22	74.00	-35.78	Peak
6	4834.05	34.64	31.53	9.56	36.86	38.87	74.00	-35.13	Peak

Note: The frequency range 6GHz to 25GHz no emission found, only report worse case.



## 6. Test Setup Photos of the EUT

Conducted Emissions (AC Mains)



Radiated Emissions (30MHz-1GHz)



Radiated Emissions (Above 1GHz)

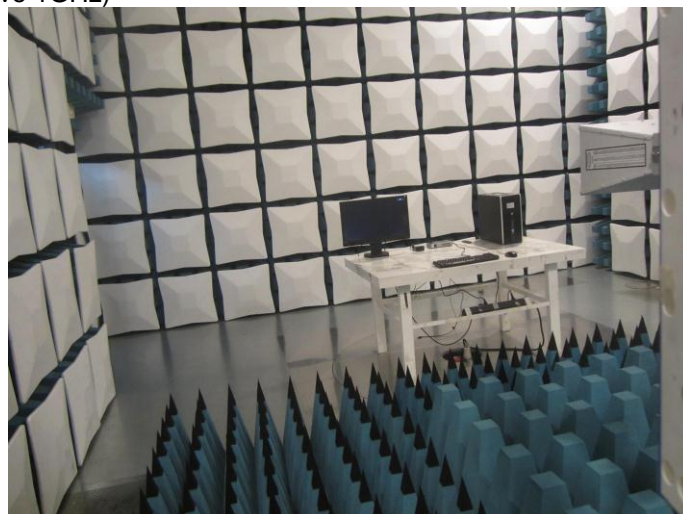

## 7. External and Internal Photos of the EUT

Reference to Test Report No.: TRE1709017301.

.....End of Report.....