



WIRELESS TECHNOLOGIES

**In-Hancer Plus
Bi-Directional Amplifier
User Manual
Installation, Operation
And Maintenance**



KAVAL WIRELESS TECHNOLOGIES
60 Gough Road
Markham, Ontario, L3R8X7
Telephone: (888) 86-KAVAL
Web: www.kaval.com
E-mail: info@kaval.com

**Document #DCM000000105, Rev.9
September 2, 2003**

PROPRIETARY STATEMENT

© 2000 KAVAL WIRELESS TECHNOLOGIES All rights reserved.

No part of this publication, or any software included with it may be reproduced, stored in a retrieval system, or transmitted in any form or by any means, including photocopying, electronic, mechanical, recording or otherwise, without the prior written permission of the copyright holder.

This document contains proprietary information of KAVAL WIRELESS TECHNOLOGIES. The contents are confidential and any disclosure to persons other than the officers, employees, agents or subcontractors of the owner or licensee of this document, without the prior written consent of KAVAL WIRELESS TECHNOLOGIES, is strictly prohibited.

KAVAL WIRELESS TECHNOLOGIES provides this document as is, without any warranty of any kind either expressed or implied including, but not limited to, the implied warranties of merchantability and fitness of a particular purpose. KAVAL WIRELESS TECHNOLOGIES may make changes or improvements in the equipment, software, or specifications described in this document at any time and without notice. These changes will be incorporated in new releases of this document.

This document may contain technical inaccuracies or typographical errors. KAVAL WIRELESS TECHNOLOGIES waives responsibility for any labour, materials, or costs incurred by any person or party as a result of using this document. KAVAL WIRELESS TECHNOLOGIES, and any of its affiliates shall not be liable for any damages (including, but not limited to, consequential, indirect or incidental, special damages or loss of profits or date) even if they were foreseeable and KAVAL WIRELESS TECHNOLOGIES has been informed of their potential occurrence, arising out of or in connection with this document or its use.

TRADE MARK NOTICE

This manual makes reference to trademarks that are the property of other companies. References are used only to refer to the products or services of the trademark owners.

In-Hancer Plus is a trademark of KAVAL WIRELESS TECHNOLOGIES

TABLE OF CONTENTS

OVERVIEW	4	<i>Mounting the In-Hancer Plus BDA</i>	15
<i>Introduction</i>	4	<i>Connections</i>	17
<i>Line Amplifier BDA's</i>	4	RF DECK CONNECTIONS	18
<i>Off-Air Operation BDA's</i>	5	BATTERY BACKUP	20
<i>Modular Construction</i>	6	IN-HANCER PLUS BDA SPECIFICATIONS.....	21
<i>Theory Of Operation</i>	6	CARRIER DE-RATING	22
STANDARD MODELS	7	INDICATORS	23
FILTER KITS	8	CONFIGURATION.....	24
ACCESSORIES	9	ANTENNA INSTALLATION.....	25
ACCESSORIES FOR STAINLESS-STEEL WEATHER- RESISTANT ENCLOSURES	10	FCC INFORMATION TO USERS	26
<i>Data Connectors & Cables</i>	10	MAINTENANCE & SAFETY	27
<i>AC Power Accessories</i>	11	STANDARD WARRANTY	27
<i>Accessory Installation</i>	12	RETURN & REPAIR	27
FIBER OPTIC OPTIONS.....	13	PARTS & ACCESSORIES.....	27
INSTALLATION.....	14		
<i>In-Hancer Plus BDA Enclosures</i>	14		
<i>Un-Packaging</i>	14		

Overview Introduction

The **In-Hancer Plus** family is a modular Bi-Directional Amplifier product. Bi-Directional Amplifiers (BDA's) are radio frequency amplifiers that amplify signals in two directions. There are two basic BDA Applications; "**Line Amplifiers**" and "**Off-Air**". Line Amplifiers are low gain (40 dB typical), while Off-Air are high gain (80 dB typical). The In-Hancer Plus does NOT have separate models for these two applications, but rather uses non volatile memory and software settings for gain.

Line Amplifier BDA's

An In-building RF distribution system takes on one of several forms including, but limited to, radiating cable, distributed tapped radiators, or high power repeater antennas. For an in-building RF distribution system that requires some gain to compensate for the system loss, Line Amplifier BDA's are best for the job. Line Amplifiers provide amplification of RF signals to recover signal loss contributed by radiating cable and other system components. The Figure below shows an example of a Tunnel RF Distribution System using Line Amplifiers. The system consists of Line Amplifiers strategically inserted between radiating cables. As the RF signal travels along the radiating cable, it loses signal strength. Line Amplifiers compensate for the RF loss by amplifying the signal back to the desired signal strength before sending it down the next distribution section, thus maintaining in-building RF seamless coverage.

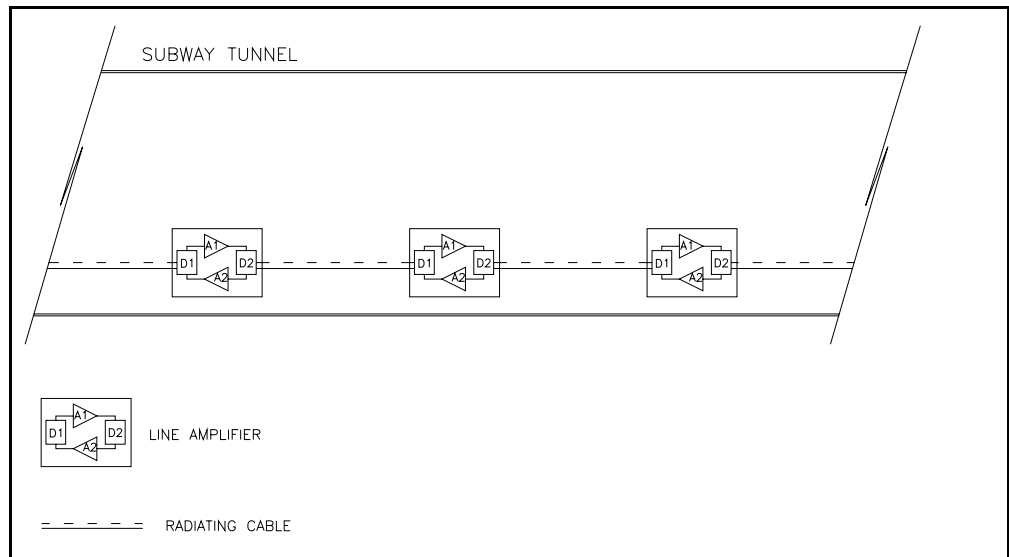

Off-Air Operation BDA's

Off-Air BDA's are intended to extend coverage into areas with coverage deficiency such as inside office buildings, shopping malls, hospitals, etc. They are designed to be located independently of the donor site and must be equipped with their own antenna systems - one to communicate with the donor site and the other(s) to communicate with portables in the shadow zone. A typical in-building coverage extension system is shown below. The "Head-End" BDA is responsible for the amplification of both incoming "Off-Air" downlink signals and outgoing uplink signals. The in-building distribution antenna system comprises of Coaxial cable, Signal taps, splitters and antennas to extend coverage on every floor, basement and underground parking garage.

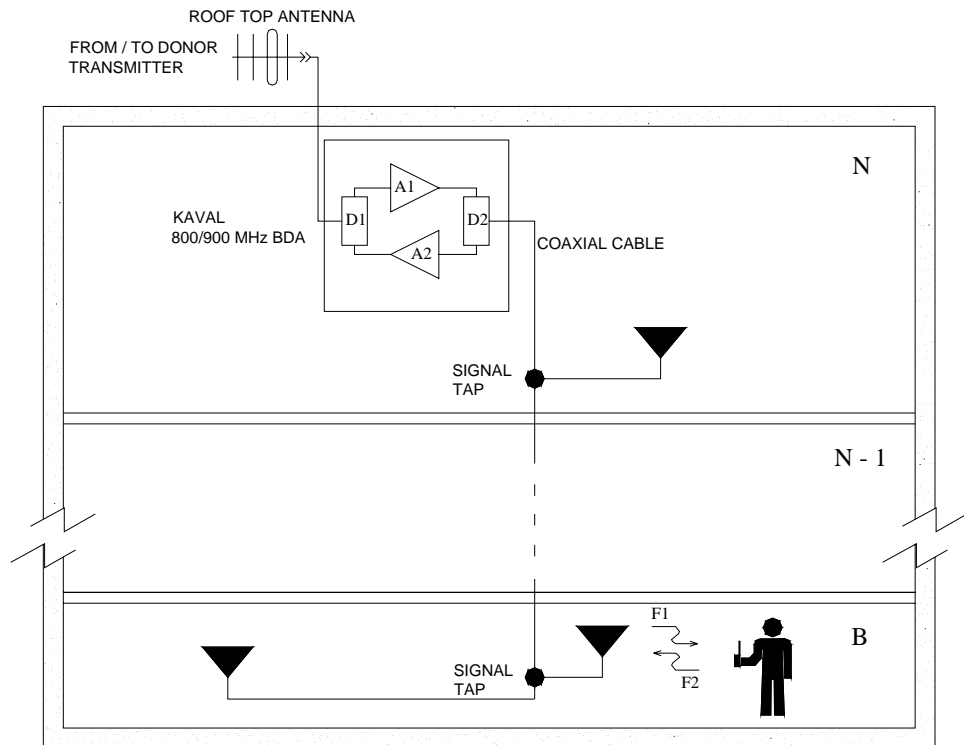

This distributed antenna system is based on Kaval Wireless Technologies' "Tapped Radiator" RF signal distribution approach. The technology makes use of coaxial cable with Signal Taps strategically located and connected to Omni-directional ground plane antennas. This technology offers flexibility in system design, installation and optimization. Once the RF cable backbone has been installed, additional signal taps and antennas can quickly and easily be added to a live system, without the need to take the system out of service. Hence, new coverage areas can be added, or the system can easily be modified if the layout should change (e.g. modernization retrofits or process modifications).

Modular Construction

The basic In-Hancer Plus BDA building blocks are.

- **RF-Deck:** an Amplifier and Controller assembly mounted on a heat-sink ready to install in an enclosure or rack. These include RF output **Isolators**.
- **Enclosure** including **Power Supply**.
- Optional **Batteries** for backup.
- **Filter Kit** including Duplexers, Filters and mounting hardware, if not already included in base Model.

This manual lists complete **Standard Models**, some of which are complete products as is, and others require the selection of a **Filter Kit**. There is also a series of add-on **Accessories and Options**.

Theory Of Operation

The In-Hancer Plus BDA uses the **RF-Deck** as the fundamental active element. RF-Decks include both Uplink and Downlink RF Amplifiers, Microprocessor based Controller, and Power Supply / Battery Charging...

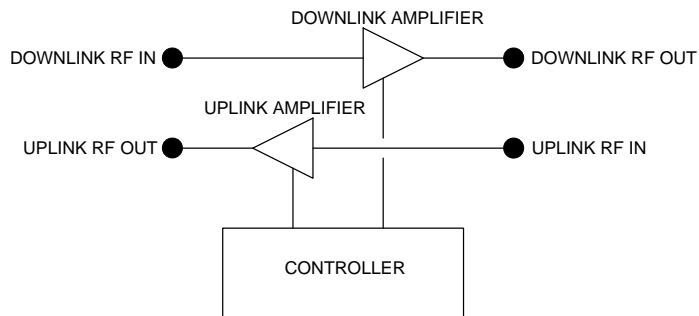

These are assembled into an enclosure with a Filter Kit...

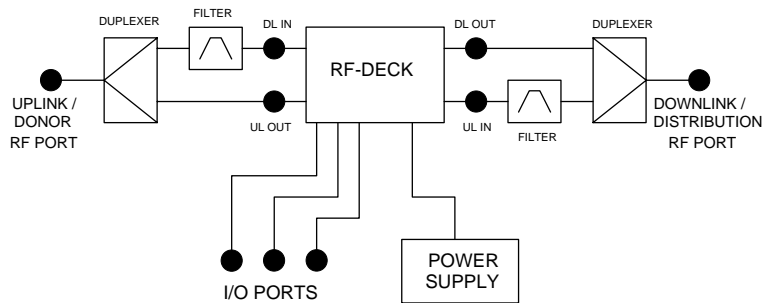

Standard Models

MODEL	DESCRIPTION	ENCLOSURE
UHF MODELS		
Note that UHF Models DO NOT include Filtering and Duplexing. See the standard Filter Kits on the next page.		
SB400-A	403-430 MHz (to 380 MHz for special applications)	Large Painted Enclosure
SB400-A-SS	403-430 MHz (to 380 MHz for special applications)	Large Stainless-Steel Enclosure
SB400-B	450-512 MHz	Large Painted Enclosure
SB400-B-SS	450-512 MHz	Large Stainless-Steel Enclosure
800-900 MHz Models		
With exceptions as noted, 800-900 MHz Models DO include Filtering & Duplexing. For the exceptions, see the standard Filter Kits on the next page.		
SB800-T	806-821 / 851-866 MHz (Trunking)	Small Painted Enclosure
SB800-T-SS	806-821 / 851-866 MHz (Trunking)	Small Stainless-Steel Enclosure
SB800-TP	806-824 / 851-869 MHz (Trunking/P-S)	Small Painted Enclosure
SB800-TP-SS	806-824 / 851-869 MHz (Trunking/P-S)	Small Stainless-Steel Enclosure
SB800-PS	821-824 / 866-869 MHz (Public Safety)	Large Painted Enclosure
SB800-PS-SS	821-824 / 866-869 MHz (Public Safety)	Large Stainless-Steel Enclosure
SB800-C	824-849 / 869-894 MHz (Full Cellular)	Small Painted Enclosure
SB800-C-SS	824-849 / 869-894 MHz (Full Cellular)	Small Stainless-Steel Enclosure
SB800-CB	835-849 / 880-894 MHz (Cell B Band)	Small Painted Enclosure
SB800-CB-SS	835-849 / 880-894 MHz (Cell B Band)	Small Stainless-Steel Enclosure
SB900-P	896-902 / 935-941 MHz (Paging)	Small Painted Enclosure
SB900-P-SS	896-902 / 935-941 MHz (Paging)	Small Stainless-Steel Enclosure
SB900-PE	896-902 / 928-941 MHz (Ext Paging)	Small Painted Enclosure
SB900-PE-SS	896-902 / 928-941 MHz (Ext Paging)	Small Stainless-Steel Enclosure
SB900-P3	896-902 / 928-941 MHz (with a tuneable 1-3 MHz Downlink Filter)	Small Painted Enclosure
SB900-P3-SS	896-902 / 928-941 MHz (with a tuneable 1-3 MHz Downlink Filter)	Small Stainless-Steel Enclosure
SB800-TPX-1	806-824 / 851-869 MHz (No Filters)	Small Painted Enclosure
SB800-TPX-1SS	806-824 / 851-869 MHz (No Filters)	Small Stainless-Steel Enclosure
SB800-TPX-2	806-824 / 851-869 MHz (No Filters)	Large Painted Enclosure
SB800-TPX-2SS	806-824 / 851-869 MHz (No Filters)	Large Stainless-Steel Enclosure
SB800-CX-1	824-849 / 869-894 MHz (No Filters)	Small Painted Enclosure
SB800-CX-1SS	824-849 / 869-894 MHz (No Filters)	Small Stainless-Steel Enclosure
SB800-CX-2	824-849 / 869-894 MHz (No Filters)	Large Painted Enclosure
SB800-CX-2SS	824-849 / 869-894 MHz (No Filters)	Large Stainless-Steel Enclosure
SB900-PX-1	896-902 / 928-941 MHz (No Filters)	Small Painted Enclosure
SB900-PX-1SS	896-902 / 928-941 MHz (No Filters)	Small Stainless-Steel Enclosure
SB900-PX-2	896-902 / 928-941 MHz (No Filters)	Large Painted Enclosure
SB900-PX-2SS	896-902 / 928-941 MHz (No Filters)	Large Stainless-Steel Enclosure

Filter Kits

KIT MODEL	DESCRIPTION
UHF Filter Kits	
SB400-F1	UHF Filter Kit for any gain, 380-512MHz, 1MHz Bandwidth, 5MHz Tx/Rx Separation. (Large Encl only)
SB400-F2L	UHF Filter Kit for up to 40dB gain, 406-512MHz, 1.5MHz Bandwidth, 3MHz Tx/Rx Separation. (Large Encl only)
SB400-F2H1	UHF Filter Kit for up to 80dB gain, 406-430MHz, 1.5MHz Bandwidth, 3MHz Tx/Rx Separation. (Large Encl only)
SB400-F2H2	UHF Filter Kit for up to 80dB gain, 450-470MHz, 1.5MHz Bandwidth, 3MHz Tx/Rx Separation. (Large Encl only)
SB400-F2H3	UHF Filter Kit for up to 80dB gain, 470-512MHz, 1.5MHz Bandwidth, 3MHz Tx/Rx Separation. (Large Encl only)
SB400-F3	UHF Filter Kit for any gain, 406-512MHz, 1.5MHz Bandwidth, 5MHz Tx/Rx Separation. (Large Encl only)
SB400-F4L	UHF Filter Kit for up to 40dB gain, 406-512MHz, 3MHz Bandwidth, 5MHz Tx/Rx Separation. (Large Encl only)
SB400-F4H1	UHF Filter Kit for up to 80dB gain, 406-430MHz, 3MHz Bandwidth, 5MHz Tx/Rx Separation. (Large Encl only)
SB400-F4H2	UHF Filter Kit for up to 80dB gain, 450-470MHz, 3MHz Bandwidth, 5MHz Tx/Rx Separation. (Large Encl only)
SB400-F4H3	UHF Filter Kit for up to 80dB gain, 470-512MHz, 3MHz Bandwidth, 5MHz Tx/Rx Separation. (Large Encl only)
SB400-F5	UHF Filter Kit for any gain, 380-512MHz, 5MHz Bandwidth, 10MHz Tx/Rx Separation. (Large Encl only)
800-900 MHz Filter Kits	
SB800-F-SMR	800MHz Filter Kit for 806-821 / 851-866MHz.
SB800-F-SMR-PS	800MHz Filter Kit for 806-824 / 851-869MHz.
SB800-F-PS	800MHz Filter Kit for 821-824 / 866-869MHz. (Large Encl only)
SB800-F-CELL	800MHz Filter Kit for 824-849 / 869-894MHz.
SB800-F-CELLB	800MHz Filter Kit for 835-849 / 880-894MHz.
SB900-F-PAG1	800MHz Filter Kit for 896-902 / 935-941MHz.
SB900-F-PAG2	800MHz Filter Kit for 896-902 / 928-941MHz.
SB900-F-PAG3	3MHz Add-on Filter for 851-960MHz.

For custom Filter Kits, please consult Kaval's Engineering Services.

Accessories

MODEL	DESCRIPTION
SB-BATT-CAB	Battery Cable
SB-DB15	DB15 Breakout Kit (SB-ENCL-01 & -02 only)
SB-LITE	External Status Indicator Lamp to be mounted on front of Enclosure
SB-GLAND	Cable Gland for Wires or Fiber. There are openings on the bottom of the Enclosures for these.

SB-BATT-CAB

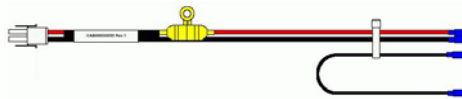

SB-DB15

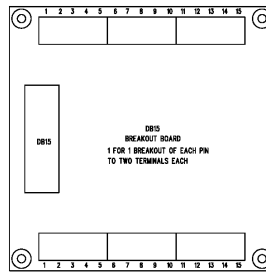

SB-LITE

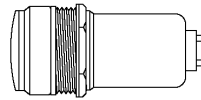

SB-GLAND



**Accessories for
Stainless-Steel
Weather-Resistant
Enclosures**

Data Connectors & Cables

For the Stainless-Steel Weather-Resistant Enclosures, if RS232 or User I/O connections are needed outside of the enclosure, then weather-resistant connections are required. These are available through cables that mount inside the enclosure, connect to the RF Deck's Control Board, and then to gasketed 8-pin connectors that mount on the enclosure bottom.

MODEL & DESCRIPTION					
Pin	SB-DATA-00 Ext Pigtail	SB-DATA-01 Relay & I/O	SB-DATA-02 CAN & I/O	SB-DATA-03 RS232	SB-DATA-03A Ext RS232
1	Black Wire	Relay NO	CAN-H	DCD In	Brings RF Deck RS232 Ports back out to a mating DB9 Connector
2	White Wire	Relay Common	CAN-L	Tx Out	
3	Red Wire	Relay NC	CAN Common	Rx In	
4	Green Wire	Aux.In #2	Aux.In #2	RI In	
5	Brown Wire	Aux.Out #2	Aux.Out #2	Ground	
6	Blue Wire	Aux.Out #3	Aux.Out #3	+5 VDC Power	
7	Orange Wire	Ground	Ground	CTS In	
8	Yellow Wire	+28 VDC Power	+28 VDC Power	RTS Out	
	Used Outside Enclosure	Used Inside Enclosure	Used Inside Enclosure	Used Inside Enclosure	Used Outside Enclosure

Note that the CAN Network connection is optically-isolated, so the CAN Common line is NOT the same as ground.

The circular 8-pin connectors have a sealed cap/cover to protect the connector when not in use.



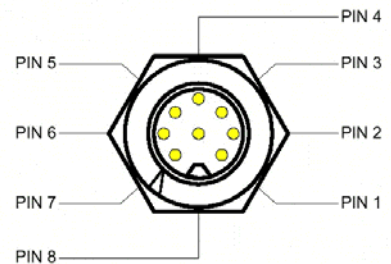

Custom cables may be defined.



SHOWN FROM THE REAR OF THE 8-PIN MALE CONNECTOR

AC Power Accessories

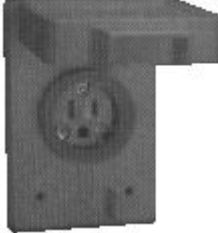
The AC Power is brought into the Stainless-Steel Enclosure via a water-tight cable that is included with the In-Hancer Plus BDA. Optional Accessories include...

MODEL	DESCRIPTION	PHOTO
SB-AC-CORD1	Replacement Water-Tight AC Line Cord 8'	
SB-EXT-CORD	Water-Tight Extension Cord 25'	
SB-OUTLET1	Water-Tight AC Outlet with Cover	
SB-AC-BOX1	AC Box for Outlet with 1/2" Knockout	
SB-AC-BOX2	AC Box for Outlet with 3/4" Knockout	
SB-AC-BOX3	AC Box for Outlet with 1" Knockout	

Accessory Installation

For the Stainless-Steel Weather-Resistant Enclosures, most external accessories install on the bottom, except for the **SB-LITE** which mounts on the door.

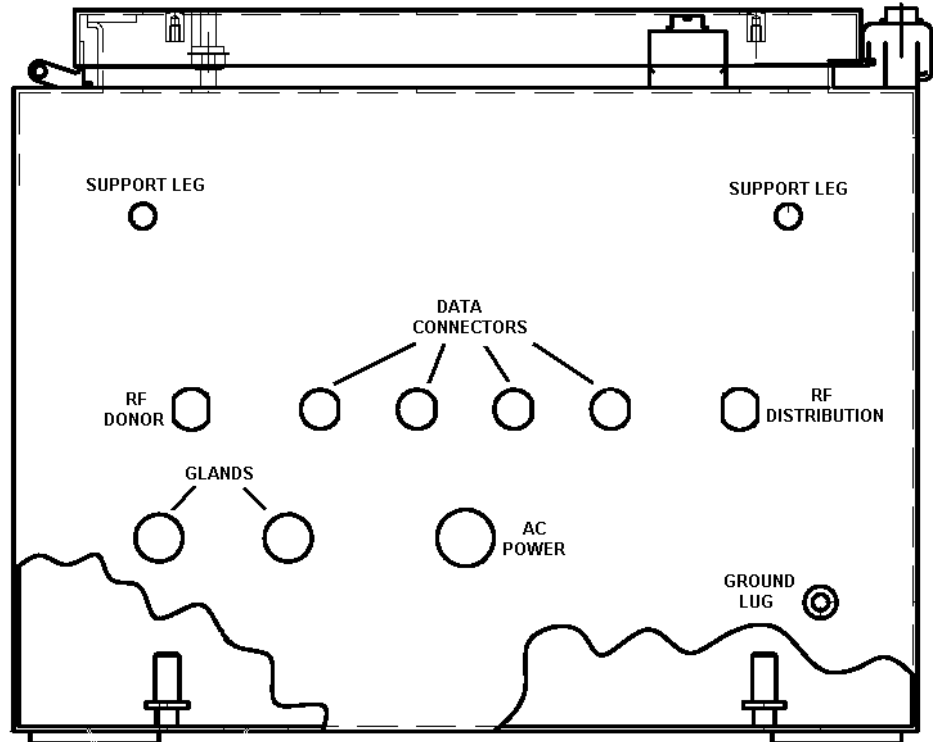

There are openings on the bottoms of the Enclosures for 4 Data Connectors and two of optional SB-GLAND. When not used these openings are sealed with weather-resistant plugs...



Replacements for these may be ordered as Kaval Part **SB-PLUG**.

Fiber Optic Options

MODEL	DESCRIPTION
SB-FIB13 Fiber-Optic I/F	RF over Fiber Interface Module, Dual-Fiber 1310 nM Laser
SB-FIB13W Fiber-Optic I/F	RF over Fiber Interface Module, Single-Fiber (WDM) 1310 nM Laser
SB-FIB15 Fiber-Optic I/F	RF over Fiber Interface Module, Dual-Fiber 1550 nM Laser
SB-FIB15W Fiber-Optic I/F	RF over Fiber Interface Module, Single-Fiber (WDM) 1550 nM Laser



These are Factory Installed Options. Consult Kaval's Engineering Services for more information.

Installation In-Hancer Plus BDA Enclosures

There are four standard BDA Enclosures, 2 sizes (Large and Small) of **Painted Enclosures** suitable for use in Electrical Rooms, and 2 sizes (Large and Small) of **Stainless-Steel Enclosures** which are sealed for enhanced Weather / Water Resistance.



Painted Enclosure Photo is TBD

Un-Packaging

Each In-Hancer Plus BDA is carefully packaged for air shipment. Any damage incurred during the transportation must be claimed from the shipper. Make sure the following necessary equipment and hardware are available and undamaged.

- In-Hancer Plus BDA (supplied by Kaval Wireless Technologies)
- Two 50-Ohm jumper cables (not supplied by Kaval Wireless Technologies)
- AC power cord.
- AC Outlet is nearby (not supplied by Kaval Wireless Technologies)
- Mounting hardware such as: Four washers and four bolts (not supplied by Kaval Wireless Technologies)
- Make sure the mounting area is large enough to accommodate the installation of the enclosure and free airflow is available on both sides of the cabinet.

Mounting the In-Hancer Plus BDA

The physical installation is accomplished by mounting the enclosure onto a vertical wall. Ensure that the unit is mounted in the upright position, as indicated by the upright Kaval Wireless Technologies' logo. Using four mounting lugs on the enclosure as a template insert four bolts to the wall. Make sure the bolts are capable of supporting the weight. The enclosure can be mounted as described below:

- Raise the enclosure so that it about 1" to 3" away from the bolts so that one can see the bolts through the larger diameter of the keyhole slots.
- Move the enclosure closer to the wall so that those four keyhole type slots are hooked onto the bolts.
- Slide the enclosure down until all bolts fit well in the narrow part of the keyhole slots.

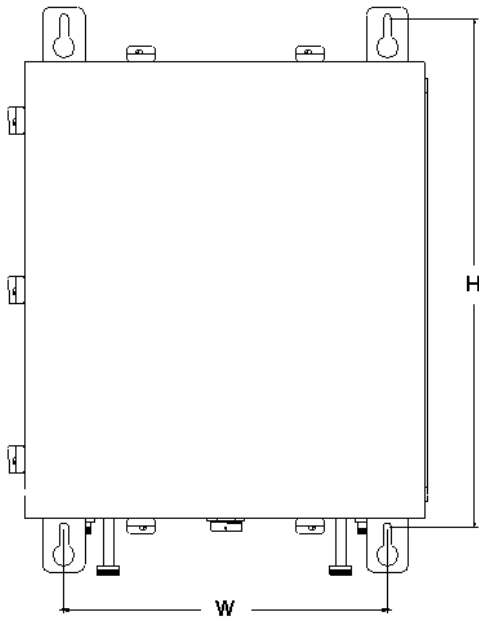

Enclosure

Small Painted Enclosure
Small Stainless Steel Enclosure
Large Painted Enclosure
Large Stainless Steel Enclosure

<u>"H"</u>	<u>"W"</u>
TBD	TBD
18.0"	11.5"
TBD	TBD
26.0"	18.0"

NOTE: The Stainless Steel Enclosures are sealed for enhanced Weather / Water Resistance.

The Small Stainless Steel Enclosure may also be mounted onto an optional Mounting Plate for quick installation and replacement...

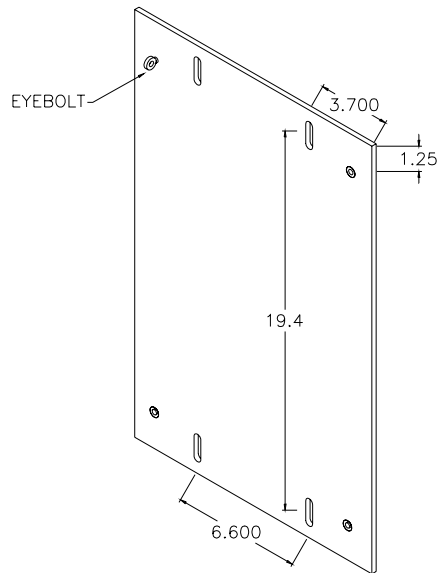

This is especially important in Subway Tunnel applications...

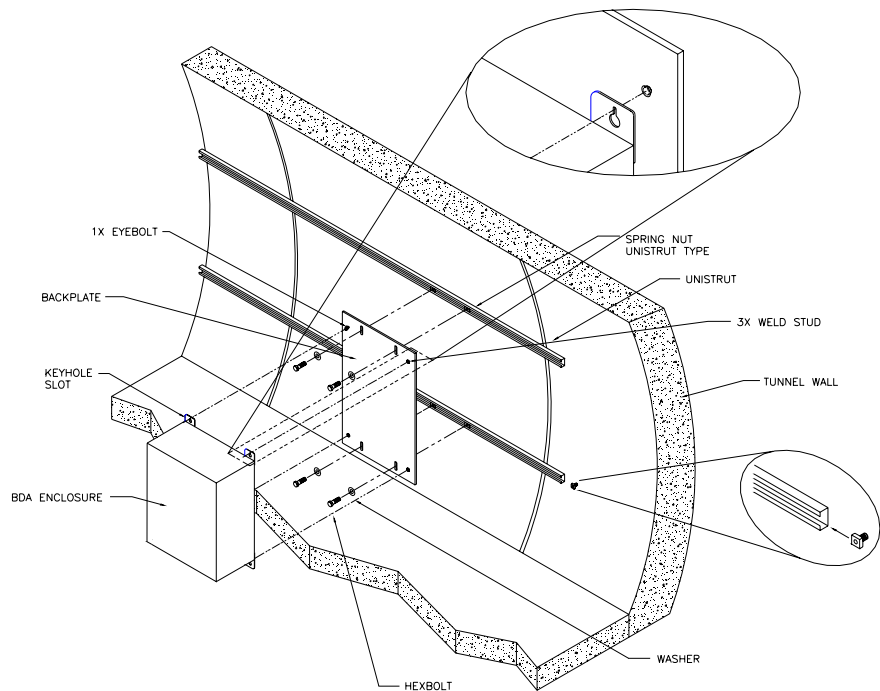

Connections

In-Hancer Plus BDA Connectors are on the bottom of the enclosure. RF cables can be connected to these connectors using RF cables as follows.

- Connect the in-building Distributed Antenna System cable to the Uplink port.
- Connect the Donor Site cable to the Downlink port.
- Connect AC Power.
- Connect any Data Cables.

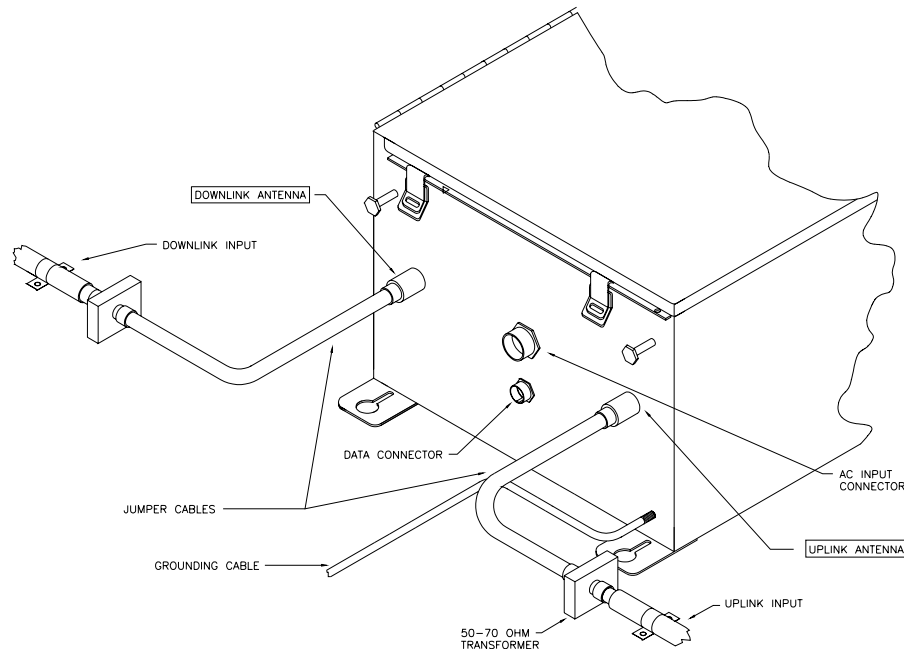

AC Power and RF Connections should be installed with all standard installation practices for lightning protection. This includes the grounding and electrical bonding together of all equipment racks and cabinets in the room. It also includes a grounding of the primary antenna cable and the installation of proper surge suppression (lightning arrester) equipment at the entrance to the equipment room. It is highly recommended that AC Power Wiring be performed by a qualified Electrician so as to ensure compliance with all National and Local Electrical Wiring Regulations. Connecting power cables can be done as follows:

- The In-Hancer Plus BDA enclosure can be grounded by connecting a No. 6 copper grounding wire to the grounding stud located at the bottom of the enclosure.
- Connect the power cable to the AC INPUT connector located at the bottom of the enclosure.
- Set the In-Hancer Plus BDA operating parameters using a PC or via the CAN Network.

RF Deck Connections

As previously described, the core of an In-Hancer Plus BDA is the RF Deck. The diagram below shows the RF Deck, its Indicators and Connectors...

RS232 Connectors:

RS232 Port #1 is for connecting directly to a PC via a straight-through male to female DB9 cable. The PC interface is described later.

RS232 Port #2 is for special software defined interfacing.

Pin#	Signal	Direction
1 *	DCD	Input
2	Tx	Output
3	Rx	Input
5	Ground	
6	+5V	Output
7	CTS	Input
8	RTS	Output
9 *	RI	Input

* RS232 Port #2 Only !

The +5V is current limited to about 0.5 ampere maximum.

User I/O Connector:

This provides a variety of I/O functionality via a 15-pin Female D-Sub Connector...

Pin#	Signal
1	CAN High (isolated)
9	CAN Low (isolated)
8	CAN Com. (isolated)
3	Fault Relay Common
2	Fault Relay - Closed for Fault
5	Fault Relay - Open for Fault
6	+28V Power
7	Ground
10	Auxiliary Input #1
11	Auxiliary Input #2
12	Auxiliary Input #3
13	Auxiliary Output #1
14	Auxiliary Output #2
15	Auxiliary Output #3

Note that the CAN Network connection is optically-isolated, so the CAN Common line is NOT the same as ground. Auxiliary Output #1 is also available at connector J2, and Auxiliary Input #1 is also available at connector J19.

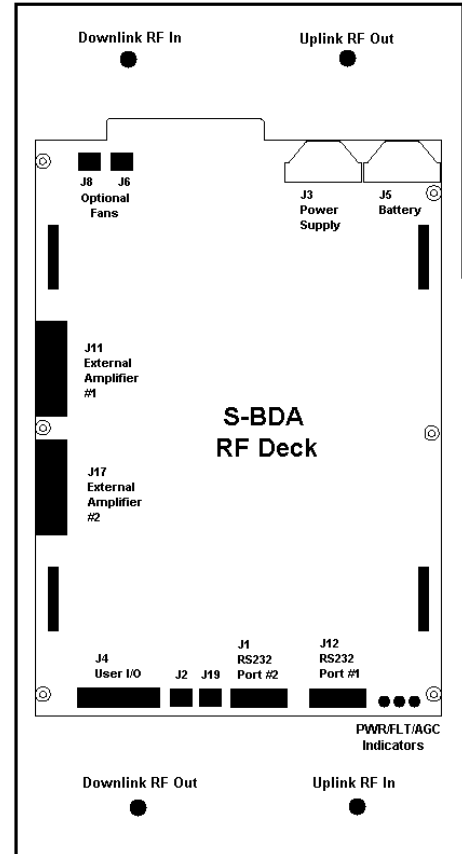

The **+28V Power** is current limited to about 0.5 ampere maximum.

The Form-C **Fault Relay** is rated at 30 VDC 30 VAC @ 0.5 Amp.

For the **CAN Network** wiring, refer to the **DCM000000103 CAN Wiring Guide**.

The three **Auxiliary Inputs** are intended for connection to external contact-closures connected between the input and ground. Each one, if closed, will create a Fault Condition Auxiliary Input #1 is also available at connector J19.

The three **Auxiliary Outputs** are intended for connection to external devices such as relay coils or lamps. The external devices are connected between the output and +28V. They are rated at 100mA each. Auxiliary Output #1 is intended for use with the **SB-LITE** optional External Status Indicator Lamp, and is available for that application via connector J2. The function of Auxiliary Output #1 - the Status Light, is...

Normal Operating Conditions	-	Lighted Steadily.
Fault Conditions	-	Flashing
Loss of all Power	-	Off

The other two Auxiliary Outputs are to be custom software configured.

Note that the **SB-DB15 DB15 Breakout Kit** may be ordered to bring the User I/O connections out to screw terminals for easy wiring...

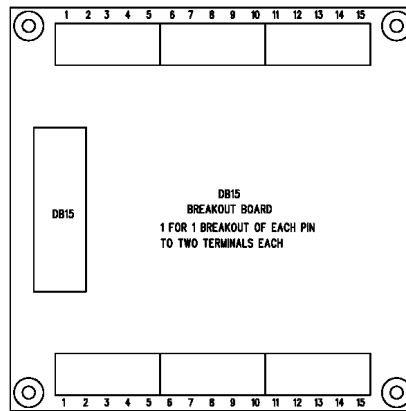

This 4" x 4" Board mounts onto four 3.5" x 3.5" #6 locations, and includes a 6' DB15 to DB15 Cable.

For the Weather-Resistant Enclosures use the Data Cables.

Power Supply: Connected to the internal 28VDC Power Supply.

Battery: Connected to an optional Backup Battery.

RF Connections: As described, these would be configured internally by Kaval.

Battery Backup If the In-Hancer Plus BDA is being used without a Battery it must be configured to NOT use a battery. Without a battery the BDA will shut down or reset with any disruption to the AC power. When power is re-established the system will restart automatically within 30 seconds. External batteries may be connected using the **SB-BATT-CAB Battery Cable**. The BDA has a built-in battery charger that will automatically recharge the attached battery.

Refer to **DCM00000102 "Battery Backup Manual"**.

For Battery Backup purposes...

Vbat = 24 VDC Ic = 0.5 Ampere Id = 2.5 Ampere

In-Hancer Plus BDA Specifications

Frequency Bands	See Model Charts
Passband Ripple (Typical)	± 2.5 dB (Depends upon Filtering choices)
Gain Range (Typical)	30 to 80dB Typical for 800-900 MHz Models 28 to 78dB for UHF Models (the gains have some variation for certain filtering combinations)
Digital Gain Adjustment	In 1 dB Increments
AGC (Power Levelling)	When active will limit composite output power to a level between +15 to +30dBm. Has fast attack and slow decay so as to NOT interfere with complex signals such as CDMA, GSM, iDEN, etc.
AGC Dynamic Range	40dB for 800-900 MHz Models 25dB for UHF Models
RF Power 3'rd Order Intercept Point IP3	+45 dBm Typical for 800-900 MHz Models +44dBm Typical for UHF Models (see de-rating chart)
Noise Figure	< 8 dB for 800-900 MHz Models <12dB for UHF Models
Propagation Delay	<5 µs (dependent upon filtering choices)
Impedance	50 ohms
VSWR	<2:1
Maximum RF Input	+10 dBm without damage
Primary Power	120/240VAC, 50-60Hz, 100VA Typical, 150VA Max.
Optional Secondary Power / Battery Backup	Two 12 VDC Sealed Lead -Acid Batteries, 10-100 AH. See DCM00000102.
Dimensions W x H x D (incl. Heatsink, but NOT Mounting Tabs)	Approx. 17"x16.5"x11" for Small Enclosures Approx. 27"x24"x11" for Large Enclosures
Weight	60 lbs. approx. for Smaller Enclosure 120 lbs. approx. for Larger Enclosure
Housing	Rugged - Wall Mountable Stainless Steel options for weather resistant.
Connectors	N female
Operating Temperature Range	-10°C to +50°C
Humidity	5% to 95% RH Max, Non-Condensing
FCC Identifier	FCC: H6M-SB400 UHF H6M-SB800 800-900 MHz
Industry Canada Certification	IC: 1541A-SB400 UHF 1541A-SB800 800-900 MHz

NOTE: The Stainless Steel Enclosures are sealed for enhanced Weather / Water Resistance.

Carrier De-Rating

There are two requirements for the de-rating of RF Carriers in a multiple channel environment; one is Intermodulation - signals produced from non-linear effects between the intended channel signals. This intermodulation may cause interference to receiving equipment. In order to minimize Intermodulation signals, Power de-rating must be applied. In the USA there are FCC Intermodulation Specifications published in the EIA Standard PN2009.

The second requirement is de-rating to maintain the integrity of complex digital communications signals.

The Tables below gives the maximum per channel Output Levels allowed as a function of the number of channels. Note that depending on the actual input levels, the gain may need to be reduced.

The figures shown are to the nearest dB, and are for the 800-900MHz In-Hancer Plus BDA's. For UHF Models a further de-rating of 2dB is required.

FM Carriers (output levels) (for 800-900MHz; de-rate by -1 to -2 dB for UHF)			Complex Carriers (output levels) (CDMA, GSM, iDEN, etc) (for 800-900MHz; de-rate by -1 to -2dB for UHF)		
Number of Carriers	Power per Carrier (dBm)	Total Power (dBm)	Number of Carriers	Power per Carrier (dBm)	Total Power (dBm)
1	+37	+37	1	+27	+27
2	+26	+29	2	+21	+24
3	+23	+28	3	+18	+23
4	+21	+27	4	+16	+22
5	+19	+26	5	+14	+21
6	+18	+26	6	+13	+21
7	+17	+25	7	+12	+20
8	+16	+25	8	+11	+20
9	+15	+25	9	+10	+20
10	+14	+24	10	+9	+19
15	+12	+24	15	+7	+19
20	+10	+23	20	+5	+18
25	+9	+23	25	+4	+18
30	+8	+22	30	+3	+17

Maintaining the above composite output power levels may be accomplished by setting both Gain and AGC Levels appropriately.

Consult Kaval Wireless Technologies for further information.

Indicators The three LED Indicators on the RF Deck are...

POWER:	This LED will be GREEN when the BDA is operating.
FAULT:	This LED will light AMBER for any Fault Condition.
AGC:	This LED will light AMBER when the Power Limiting is on.

The optional **SB-LITE External Lamp** indicates...

Normal Operating Conditions:	Lighted Steadily.
Fault Conditions:	Flashing
Loss of all Power:	Off

The In-Hancer Plus BDA continuously performs internal diagnostics. If a fault is detected it will activate its Fault LED and Fault Relay. Faults detected include...

- Over Temperature
- Over / Under Current
- Misc. Internal Faults

Detailed Faults are detected by the optional Gateway Module. Details may also be determined via an RS232 connected Terminal Emulator using the **LIST** command.

Configuration It is possible to re-configure an **In-Hancer Plus BDA** in the field, either with a **Personal Computer (PC)** or via the optional **LinkNet Gateway Module**. To use a **PC** it is necessary to use a straight-through DB9 male to female cable to connect the RS232 Port #1 DB9 connector on the RF Deck to a standard DB9 RS232 Connector on the PC. On the PC a terminal emulation program such as **HyperTerminal** is used to communicate to the In-Hancer Plus BDA. The settings are 9600 baud, 8 bits, no parity, and 1 stop bit. Commands are one or two words followed by pressing *Return*. Commands may be given in upper or lower-case. Available commands are...

ACCESS USER	Required as a simple password to gain access to customer settable parameters and diagnostics; This will time-out after 10 minutes, and may have to be re-typed.
HELP or ?	Displays a list of Available Commands.
LIST	Displays Current Settings and Status Faults, Etc.
VER	Display the current Version of Software.
ENABLE 1 or 0	Enables or Disables the Module.
DLEN 1 or 0	Enables or Disables the Downlink Amplifier.
ULEN 1 or 0	Enables or Disables the Uplink Amplifier.
DLGAIN ###	Displays or Sets the Downlink Gain (in tenths of a dB).
ULGAIN ###	Displays or Sets the Uplink Gain (in tenths of a dB).
DLAGC ###	Displays or Sets the Downlink AGC Level (in tenths of a dBm).
ULAGC ###	Displays or Sets the Uplink AGC Level (in tenths of a dBm).
DLAGCEN 1 or 0	Enables or Disables Downlink AGC.
ULAGCEN 1 or 0	Enables or Disables Uplink AGC.
NETID ###	Sets the Network ID.
BACKUP 0, 1, or 2	Sets the Power Supply Backup to None (0), Battery (1), Power Supply (2).

Please consult Kaval Wireless Technologies for further support.

Antenna Installation

- All Antenna Installation to be performed by Qualified Technical Personnel only.
- Antenna Installation Instructions and locations below are for the purpose of satisfying FCC RF Exposure Compliance requirements.
- The *Roof Top Antenna or Antennae* for linking to the *Donor Site(s)* is/are directional (high gain) Antennae, fixed-mounted physically on the side or top of a building, or on a tower. The Antenna Gain must be no more than 10 dB. The *Roof Top Antennae* location should be such that only Qualified Technical Personnel can access it, and that under normal operating conditions no other person can touch the Antenna, or approach within 10 meters of the Antenna.
- The *In-Building Antenna* connection is via a coaxial cable distribution system with Signal Taps at various points connected to the fixed-mounted *Indoor Antennae*. This is shown in the figure in the Introduction. The *Indoor Antennae* are simple 1/4 Wavelength (0 dB Gain) types. They are used with KAVAL WIRELESS TECHNOLOGIES 12, 16, or 20 dB Cable Taps. As such the maximum EIRP will be at the first Tapped Antenna, which will be 12 dB below the maximum signal level of the BDA (+40 dBm); +28 dBm, or 0.63 Watts EIRP. These Antennae are to be installed such that no person can touch the Antenna, or approach within 0.2 Meters.



**ANTENNA INSTALLATION
WARNING**

ALL ANTENNA INSTALLATION IS TO BE PERFORMED BY QUALIFIED TECHNICAL PERSONNEL ONLY.

ANTENNA INSTALLATION INSTRUCTIONS AND LOCATIONS ARE FOR THE PURPOSE OF SATISFYING FCC RF EXPOSURE COMPLIANCE REQUIREMENTS, AND ARE NOT OPTIONAL.

ALL ROOF TOP ANTENNA INSTALLATION MUST BE SUCH THAT NO PERSON CAN TOUCH THE ANTENNA, OR APPROACH CLOSER THAN 10 METERS.

ALL IN-BUILDING ANTENNAE INSTALLATIONS MUST BE SUCH THAT NO PERSON CAN TOUCH THE ANTENNAE, OR APPROACH CLOSER THAN 0.2 METERS.

Please consult Kaval Wireless for assistance as required.

FCC Information to Users

- This equipment has been tested and found to comply with the limits for a Class A digital device, pursuant to Part 15 of the FCC Rules. These limits are designed to provide reasonable protection against harmful interference when the equipment is operated in a commercial environment. This equipment generates, uses, and can radiate radio frequency energy and, if not installed and used in accordance with the instruction manual, may cause harmful interference to radio communications. Operation of this equipment in a residential area is likely to cause harmful interference in which case the user will be required to correct the interference at his own expense.



WARNING

**CHANGES OR MODIFICATIONS NOT EXPRESSLY APPROVED BY KAVAL
COULD VOID THE USER'S AUTHORITY TO OPERATE THE EQUIPMENT.**

Maintenance & Safety

The In-Hancer Plus BDA has been engineered for easy maintenance and for safe operation. This has been achieved as follows:

- The BDA provides fault monitoring and accurate status reporting.
- The 28V DC Power-supply is over-rated for actual requirements.
- Amplifiers are monitored for both Over-current and Under-current (most failures are sensed this way).
- Cabinet temperature is monitored for excessive temperature.
- Components are easily removable via quick connect DC and RF connectors.

Standard Warranty

Please contact Kaval Wireless Technologies for a copy of the Standard Product Warranty.

Return & Repair

The In-Hancer Plus BDA can be returned for repair by the following procedures:

- Contact Kaval Wireless Technologies Inc. at 1888-86-KAVAL for a Return Materials Authorization (RMA) number. Please provide serial number and model number.
- Ship the defective part prepaid in the original shipping box to:

Kaval Wireless Technologies Inc.
ATTN: Returned Part; RMA number: XXXX
60 Gough Road
Markham, Ontario, Canada
L3R 8X7

Parts & Accessories

Parts and accessories for the In-Hancer Plus BDA may be purchased by contacting Kaval Wireless Technologies Inc. at 1-888-86-KAVAL for prices and delivery. When ordering a replacement part, please provide model number, serial number and software version number.