



**FCC ELECTROMAGNETIC EMISSIONS COMPLIANCE
REPORT
CERTIFICATION TO FCC PART 15 REQUIREMENTS**

For

INTENTIONAL RADIATOR

of

Car Alarm Transceiver

FCC ID Number : H5OTR19

Trade Name : Advance Security Inc.

Model Number : TRX96

Agency Series : N/A

Report Number : 61027202-RP1

Date : November 14, 2006

Issued to

Advance Security Inc.

3F, 48 Ta An Street, Hsi Chih, Taipei Hsien,

TAIWAN R.O.C.

Issued by

Compliance Certification Services Inc.

Hsintien Lab.

No. 163-1, Chunghsen Road, Hsintien City

Taipei Hsien, Taiwan

TEL: (02) 2217-0894

FAX: (02) 2217-1029



ACCREDITED
No. 0824-01

Note: This report shall not be reproduced except in full, without the written approval of Compliance Certification Services Inc. Ltd. This document may be altered or revised by Compliance Certification Services Inc. personnel only, and shall be noted in the revision section of the document.



TABLE OF CONTENTS

1. VERIFICATION OF COMPLIANCE.....	3
2. PRODUCT DESCRIPTION	4
3. TEST FACILITY	4
4. MEASUREMENT STANDARDS.....	4
5. TEST METHODOLOGY.....	4
6. MEASUREMENT EQUIPMENT USED	5
7. POWERLINE RFI LIMIT	5
8. RADIATED EMISSION LIMITS	6
9. SYSTEM TEST CONFIGURATION	6
10. TEST PROCEDURE	8
11. EQUIPMENT MODIFICATIONS	9
12. TEST RESULT	10
12.1. MAXIMUM MODULATION PERCENTAGE (M%).....	10
12.2. THE EMISSIONS BANDWIDTH	10
APPENDIX I TEST DATA	11



1. VERIFICATION OF COMPLIANCE

COMPANY NAME : Advance Security Inc.
 3F, 48 Ta An Street, Hsi Chih, Taipei Hsien,
 TAIWAN R.O.C.

CONTACT PERSON : Michael Chen / President

TELEPHONE NO. : 886-2-8648-1688

EUT DESCRIPTION : Car Alarm Transceiver

MODEL NAME/NUMBER : TRX96

FCC ID : H5OTR19

DATE TESTED : October 28, 2006 ~ November 10, 2006

REPORT NUMBER : 61027202-RP1

TYPE OF EQUIPMENT	SECURITY EQUIPMENT (INTENTIONAL RADIATOR)
EQUIPMENT TYPE	915 MHz Car Alarm Transceiver
MEASUREMENT PROCEDURE	ANSI 63.4 / 2003
LIMIT TYPE	CERTIFICATION
FCC RULE	CFR 47, PART 15

The above equipment was tested by Compliance Certification Services Inc. for compliance with the requirements set forth in the FCC CFR 47, PART 15. The results of testing in this report apply to the product/system which was tested only. Other similar equipment will not necessarily produce the same results due to production tolerance and measurement uncertainties. **Warning:** This document reports conditions under which testing was conducted and results of tests performed. This document may not be altered or revised in any way unless done so by Compliance Certification Services Inc. and all revisions are duly noted in the revisions section. Any alteration of this document not carried out by Compliance Certification Services Inc. will constitute fraud and shall nullify the document.

Approved by:

David Wang
 Manager of Hsintien Laboratory
 Compliance Certification Services Inc.

Reviewed by:

Vince Chiang
 Assistant Manager of Hsintien Laboratory
 Compliance Certification Services Inc.



2. PRODUCT DESCRIPTION

Fundamental Frequency	915 MHz
Power Source	12VDC
Transmitting Time	Periodic \leq 5 seconds
Associated Transceiver	FCC ID: H5OTR20

3. TEST FACILITY

The open area test sites and conducted measurement facilities used to collect the radiated data are located at No. 163-1, Chungshen Road, Hsintien City, Taipei Hsien, Taiwan, R.O.C. The sites are constructed in conformance with the requirements of ANSI C63.7, ANSI C63.4 and CISPR Publication 22.

4. MEASUREMENT STANDARDS

The site is constructed and calibrated in conformance with the requirements of ANSI C63.4/2003.

5. TEST METHODOLOGY

For an intentional radiator, the spectrum shall be investigated from the lowest radio frequency signal generated in the device, without going below 9 KHz, up to at least the tenth harmonic of the highest fundamental frequency or to 40 GHz, whichever is lower. (CFR 47 Section 15.33)

**6. MEASUREMENT EQUIPMENT USED**

Open Area Test Site # K				
Name of Equipment	Manufacturer	Model	Serial Number	Calibration Due
SITE NSA	CCS	K Site	N/A	09/30/2007
MEASURE RECEIVER	SCHAFFNER	SCR3501	412	05/18/2007
SPECTRUM ANALYZER	ADVANTEST	R3132	120900029	No Calibration Required
ANTENNA	SCHAFFNER	CBL 6112B	2846	05/26/2007
PRE-AMPLIFIER	SCHAFFNER	CPA9231A	3639	10/10/2007
CABLE	SUHNER	RG 214	N-TYPE #K2	02/17/2007
THERMO-HYGRO METER	TFA	N/A	NO.4	02/08/2007
EMC ANALYZER (100Hz-22GHz)	HP	8566B	2937A06102	07/04/2007
ANTENNA (1-18GHz)	EMCO	3115	00022256	01/12/2007
AMPLIFIER (1-18GHz)	HP	8449B	3008A01266	02/06/2007
CABLE (1-18GHz)	JYEBAO	LL142	SMA#RS1	02/06/2007
CABLE (1-18GHz)	HUBER +SUHNER	SUCOFLEX 104	SMA#RS3	02/06/2007
CABLE (1-18GHz)	JYEBAO	LL142	SMA#C1	02/06/2007

Remark: Each piece of equipment is scheduled for calibration once a year.

SUPPORT EQUIPMENT:

No.	Device Type	Model	Brand
1.	DC Power Supply	PS140YA	DAIWA
2.	Transceiver Engine	TRX950	Advance Security Inc.

7. POWERLINE RFI LIMIT

CONNECTED TO AC POWER LINE	SECTION 15.207
CARRIER CURRENT SYSTEM IN THE FREQUENCY RANGE OF 450 KHz TO 30 MHz	SECTION 15.205 AND SECTION 15.209, 15.221, 15.223, 15.225 OR 15.227, AS APPROPRIATE.
BATTERY POWER	NO REQUIRED.



8. RADIATED EMISSION LIMITS

GENERAL REQUIREMENTS	SECTION 15.209
RESTRICTED BANDS OF OPERATION	SECTION 15.205
PERIODIC OPERATION IN THE BAND 40.66 -40.70 MHz AND ABOVE 70 MHz.	SECTION 15.231
RECEIVER MODE	SECTION 15.109

9. SYSTEM TEST CONFIGURATION

Use a block of foam and combined it with EUT wrapping rubber band around it. This way it can test X, Y and Z axis. To activate continuous transmitting & receiving, place a small plastic block between rubber band and EUT push button.



Radiated Open Site Test Set-up



Radiated Open Site Test Set-Up (Receiver Mode)



10. TEST PROCEDURE

Radiated Emissions, 15.231(4)(b)

Test Set-up for frequency range 30 – 1000 MHz

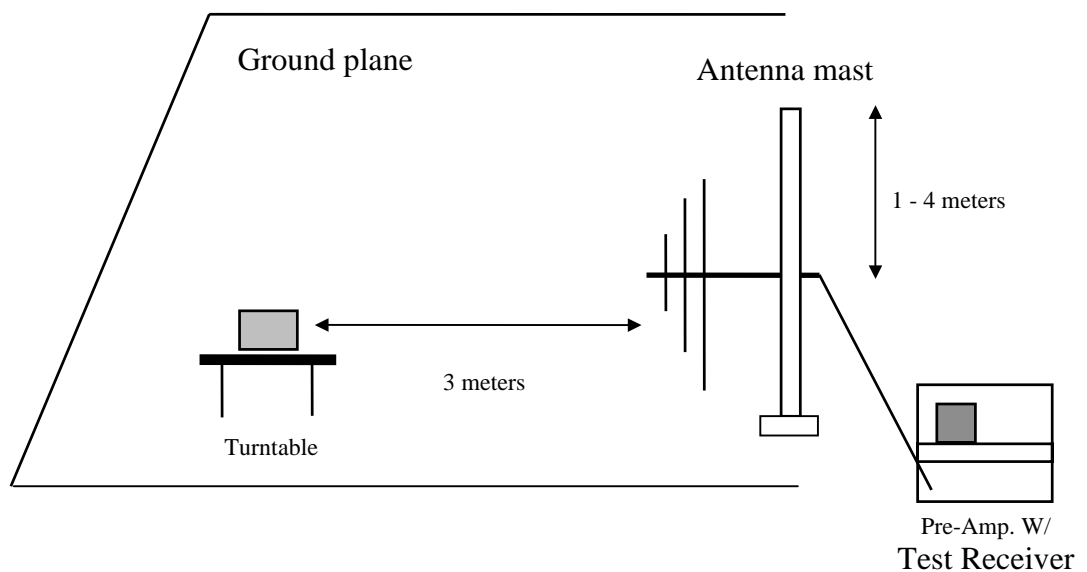

Fig. 1

1. The EUT was placed on a wooden table on the outdoor ground plane. The search antenna was placed 3-meters from the EUT.
2. The turntable was slowly rotated to locate the direction of maximum emission at each emission falling in the restricted bands of 15.205. The EUT was moved throughout the XY, XZ, and YZ planes to maximize emissions received by the search antenna.
3. Once maximum direction was determined, the search antenna was raised and lowered in both vertical and horizontal polarizations. The maximum readings so obtained are recorded in the data listed below.

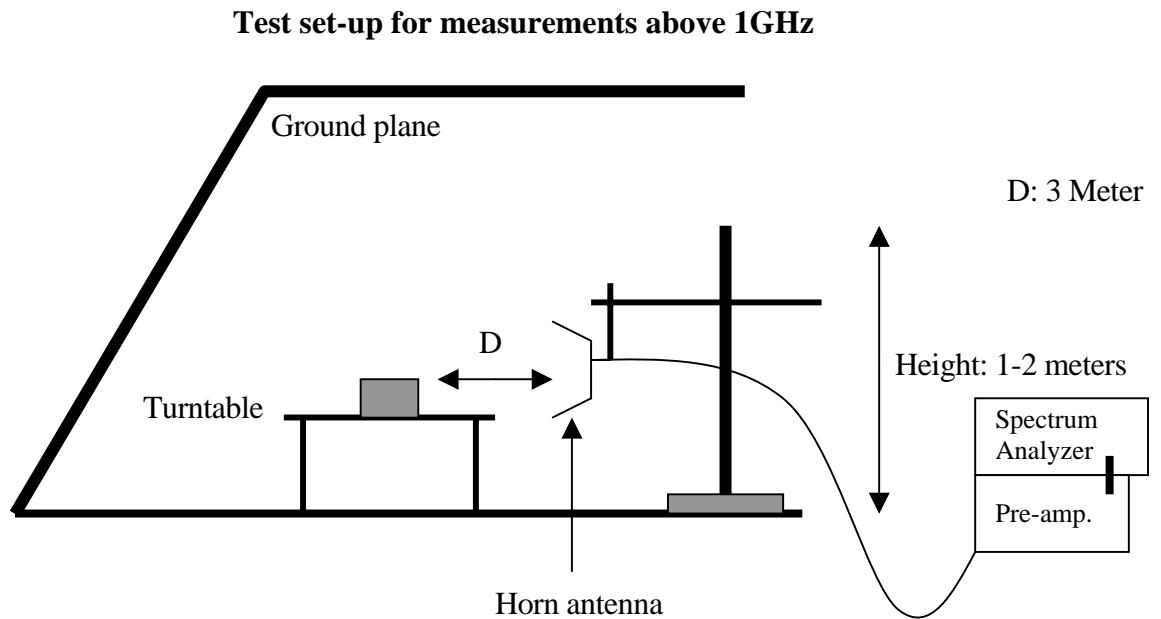

Fig. 2

1. The EUT was placed on a wooden table on the outdoor ground plane. The search antenna was placed 1-meters from the EUT. The EUT antenna was mounted vertically as per normal installation.
2. The turntable was slowly rotated to locate the direction of maximum emission at each emission falling in the restricted bands of 15.205. The EUT was moved throughout the XY, XZ, and YZ planes to maximize emissions received by the search antenna.
3. Once maximum direction was determined, the search antenna was raised and lowered in both vertical and horizontal polarizations. The maximum readings so obtained are recorded in the data listed below.

11. Equipment Modifications

To achieve compliance to FCC Section 15.231 technical limits, the following change(s) were made during compliance testing:

NONE

12. TEST RESULT

Powerline RFI Class B	Eut	Radiated Emission Limits	Eut
SECTION 15.207		SECTION 15.209	X
SECTION 15.205, 15.209, 15.221, 15.223, x 15.225 OR 15.227		SECTION 15.205	X
BATTERY POWER	X	SECTION 15.231 (b)	X
		SECTION 15.231 (e)	
		SECTION 15.109	X

12.1 Maximum Modulation Percentage (M%)

CALCULATION: No duty cycle

Note: Following is the diagram to show the modulation method of the EUT.

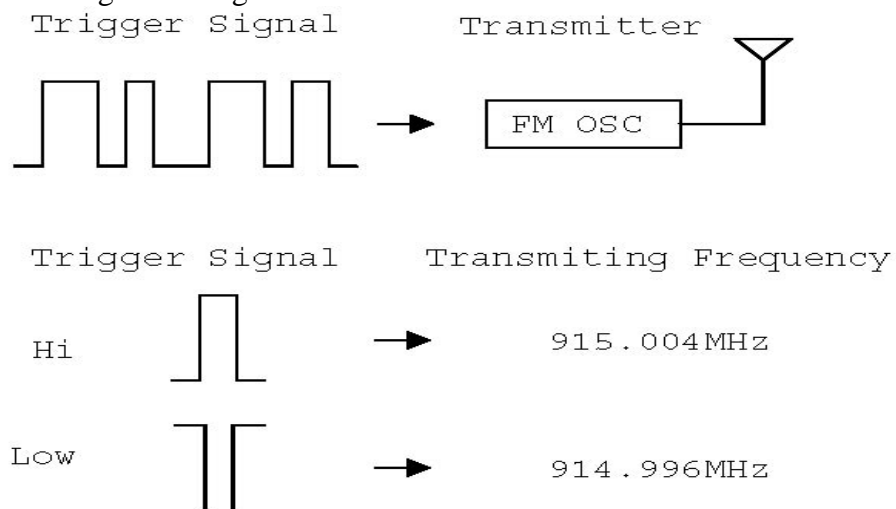

This EUT works as a FM modulation. Signal HI will trigger FM OSC to generate a 915.004MHz frequency and signal LOW will trigger FM OSC to generate a 914.996MHz frequency. It is only 0.008MHz deviation, so that there is no duty cycle on it.

12.2 The Emissions Bandwidth

The bandwidth of the emissions were investigated per 15.231(c)

Center Frequency	Measured	Limits
915MHz	355kHz < (refer to plot)	915X0.5%=4575kHz



APPENDIX I

TEST DATA



Test Plot: The Emissions Bandwidth

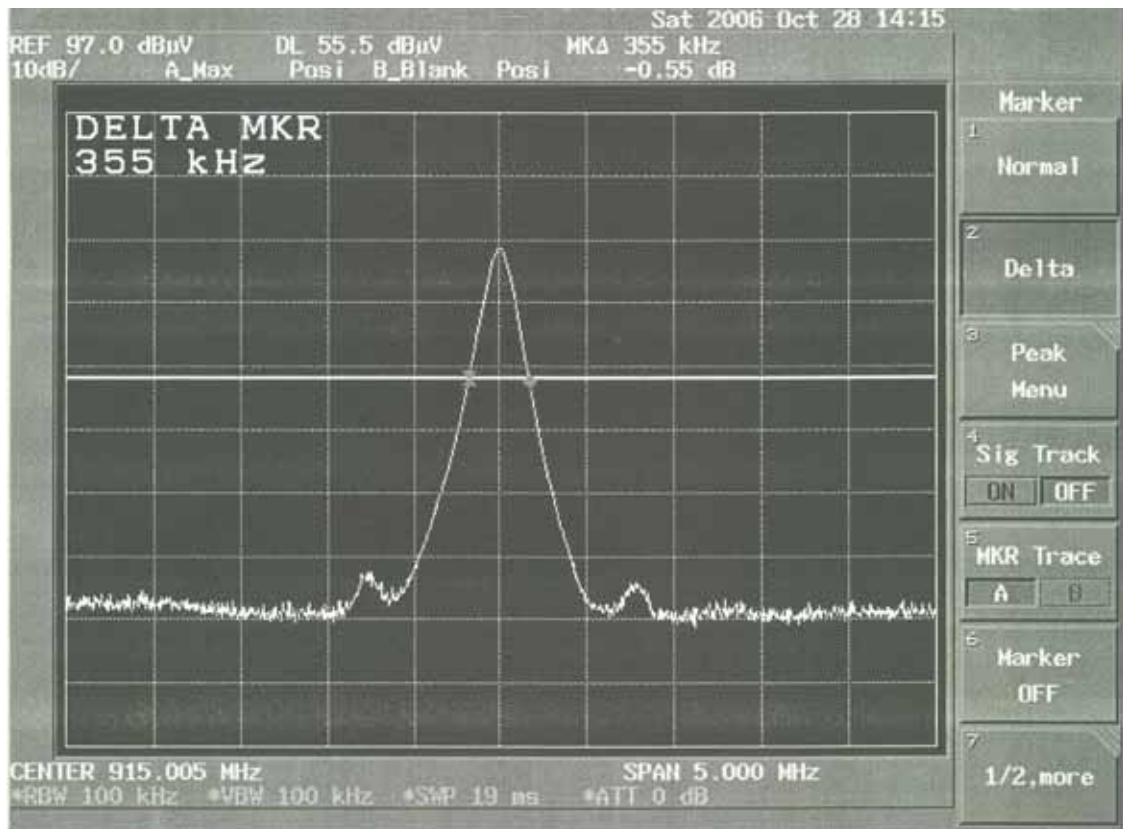

**TEST RESULTS****Below 1 GHz****Operation Mode:** TX Mode**Test Date:** November 7, 2006**Temperature:** 25°C**Humidity:** 65 % RH**Tested by:** Alex Pan

Freq. (MHz)	Pk Rdg (dBuV)	Av Rdg (dBuV)	Factor (dB)	Level (dBuV/m)	Limit (dBuV/m)	Margin (dB)	Pol (H/V)
915.01	72.80	72.80	3.18	75.98	89.84	-13.86	3mV_X
915.01	82.90	82.90	3.18	86.08	89.84	-3.76	3mV_Y
915.01	71.30	71.30	3.18	74.48	89.84	-15.36	3mV_Z
915.01	82.30	82.30	3.18	85.48	89.84	-4.36	3mH_X
915.01	76.90	76.90	3.18	80.08	89.84	-9.76	3mH_Y
915.01	81.80	81.80	3.18	84.98	89.84	-4.86	3mH_Z

Factor = Antenna Factor + Cable Loss - Pre Amplifier

Notes:

1. Measuring frequencies from 30 MHz to the 1GHz.
2. Radiated emissions measured in frequency range from 30 MHz to 1000MHz were made with an instrument using Peak detector mode.
3. Data of measurement within this frequency range shown " --- " in the table above means the reading of emissions are attenuated more than 20dB below the permissible limits or the field strength is too small to be measured.
4. The IF bandwidth of SPA between 30MHz to 1GHz was 100kHz.

**Operation Mode:** RX Mode**Test Date:** November 10, 2006**Temperature:** 25°C**Humidity:** 65 % RH**Tested by:** Alex Pan

Freq (MHz)	Amptd (dBuV/m)	Margin (dB)	Limit (dBuV/m)	Reading (dBuV)	Factor (dB/m)	Reading Type (P/Q/A)	Pol. (H/V)
110.2700	24.03	-19.47	43.50	38.60	-14.57	Q	V
163.5800	26.29	-17.21	43.50	40.23	-13.94	Q	V
492.0900	37.36	-8.64	46.00	41.20	-3.84	Q	V
522.4100	35.34	-10.66	46.00	38.10	-2.76	Q	V
564.1700	35.39	-10.61	46.00	36.90	-1.51	Q	V
615.2800	35.70	-10.30	46.00	36.60	-0.90	Q	V
249.2900	26.62	-19.38	46.00	37.50	-10.88	Q	H
351.9100	26.77	-19.23	46.00	35.60	-8.83	Q	H
380.4100	29.93	-16.07	46.00	37.40	-7.47	Q	H
502.2700	32.81	-13.19	46.00	36.40	-3.59	Q	H
567.2800	36.72	-9.28	46.00	38.20	-1.48	Q	H
615.3000	33.90	-12.10	46.00	34.80	-0.90	Q	H

Notes:

1. Measuring frequencies from 30 MHz to the 2GHz.
2. Radiated emissions measured in frequency range from 30 MHz to 1000MHz were made with an instrument using Peak detector mode.
3. Data of measurement within this frequency range shown " --- " in the table above means the reading of emissions are attenuated more than 20dB below the permissible limits or the field strength is too small to be measured.
4. The IF bandwidth of SPA between 30MHz to 1GHz was 100kHz.
5. Another transmitter trigger signal: Vertical: 915.0050MHz / 76dBuV/m
6. Another transmitter trigger signal: Horizontal: 915.0050MHz / 85.50dBuV/m

**Above 1 GHz****Operation Mode:** TX Mode**Test Date:** November 7, 2006**Temperature:** 25°C**Humidity:** 65 % RH**Tested by:** Alex Pan

Freq. (MHz)	Pk Rdg (dBuV)	Av Rdg (dBuV)	Factor (dB)	Level (dBuV/m)	Limit (dBuV/m)	Margin (dB)	Pol (H/V)
1200.00	38.60	---	-9.60	29.00	74.00	-45.00	3mV
1200.00	---	---	---	--	54.00	--	3mV
1306.00	38.00	---	-9.08	28.92	74.00	-45.08	3mV
1306.00	---	---	---	---	54.00	---	3mV
1725.00	27.50	27.50	-6.80	20.70	69.84	-49.14	3mV
1829.50	30.80	30.80	-6.10	24.70	69.84	-45.14	3mV
1360.00	31.60	---	-8.80	22.80	74.00	-51.20	3mH
1360.00	---	---	---	---	54.00	---	3mH
1415.50	29.40	---	-8.58	20.82	74.00	-53.18	3mH
1415.50	---	---	---	---	54.00	---	3mH
1830.00	27.50	11.74	-6.10	21.40	69.80	-48.40	3mH

Factor = Antenna Factor + Cable Loss - Pre Amplifier

Notes:

1. Measuring frequencies from 1 GHz to the 10th harmonic of highest fundamental frequency.
2. Measurements above show only up to 6 maximum emissions noted, or would be lesser if no specific emissions from the EUT are recorded (ie: margin>20dB from the applicable limit) and considered that's already beyond the background noise floor.
3. Radiated emissions measured in frequency above 1000MHz were made with an instrument using Peak detector mode (RBW=VBW=1MHz) of the emission shown in Rdg column.
4. Average detector mode (RBW=1MHz, VBW=10Hz) for restricted frequency bands.
5. Average measured mode (Pk Rdg -0dB) for not restricted frequency bands.
6. Data of measurement within this frequency range shown " --- " in the table above means the reading of emissions are attenuated more than 20dB below the permissible limits or the field strength is too small to be measured.



Operation Mode: N/A
Temperature: N/A
Tested by: N/A

Test Date: N/A
Humidity: N/A

Freq. (MHz)	Ant. Pol H/V	Peak Reading (dBuV)	AV Reading (dBuV)	Ant. / CL CF (dB)	Actual Fs		Peak Limit (dBuV/m)	AV Limit (dBuV/m)	Margin (dB)	Remark
					Peak (dBuV/m)	AV (dBuV/m)				
---	---	---	---	---	---	---	---	---	---	---
---	---	---	---	---	---	---	---	---	---	---
---	---	---	---	---	---	---	---	---	---	---
---	---	---	---	---	---	---	---	---	---	---
---	---	---	---	---	---	---	---	---	---	---
---	---	---	---	---	---	---	---	---	---	---
---	---	---	---	---	---	---	---	---	---	---
---	---	---	---	---	---	---	---	---	---	---
---	---	---	---	---	---	---	---	---	---	---
---	---	---	---	---	---	---	---	---	---	---
---	---	---	---	---	---	---	---	---	---	---
---	---	---	---	---	---	---	---	---	---	---
---	---	---	---	---	---	---	---	---	---	---
---	---	---	---	---	---	---	---	---	---	---
---	---	---	---	---	---	---	---	---	---	---
---	---	---	---	---	---	---	---	---	---	---

* No Any Emissions Were Found Within 20dB Below Limits From 1 GHz To 2 GHz.

Notes:

1. Measuring frequencies from 1 GHz to 2 GHz.
2. Measurements above show only up to 6 maximum emissions noted, or would be lesser if no specific emissions from the EUT are recorded (ie: margin>20dB from the applicable limit) and considered that's already beyond the background noise floor.
3. Radiated emissions measured in frequency above 1000MHz were made with an instrument using Peak detector mode and average detector mode of the emission shown in Actual FS column.
4. Spectrum Peak Setting 1GHz - 26GHz, RBW = 1MHz, VBW = 1MHz, Sweep time = Auto.
5. Spectrum AV Setting 1GH z- 26GHz, RBW = 1MHz, VBW = 10Hz, Sweep time = Auto.