

FCC ELECTROMAGNETIC EMISSIONS COMPLIANCE REPORT CERTIFICATION TO FCC PART 15 REQUIREMENTS

for

INTENTIONAL RADIATOR

of

Car Alarm Transceiver

FCC ID Number : H5OTR04

Trade Name : Advance Security Inc.

Model Number : TRX86

Agency Series : N/A

Report Number : 02E0505-D

Date : November 1, 2002

Prepared for :

Advance Security Inc.

**3F, 48 Ta An Street, Hsi Chih,
Taipei Hsien, Taiwan, R. O. C.**

Prepared by :

C&C LABORATORY CO., LTD.

**#B1, 1st Fl., Universal Center,
No. 183, Sec. 1, Tatung Rd., Hsi Chih,
Taipei Hsien, Taiwan, R.O.C.**

TEL: (02)8642-2071~3

FAX: (02)8642-2256



**This report shall not be reproduced, except in full, without the written approval of
C&C Laboratory Co., Ltd.**

TABLE OF CONTENTS

1. VERIFICATION OF COMPLIANCE	3
2. PRODUCT DESCRIPTION.....	4
3. TEST FACILITY	4
4. MEASUREMENT STANDARDS	4
5. TEST METHODOLOGY	4
6. MEASUREMENT EQUIPMENT USED	5
7. POWERLINE RFI LIMIT.....	5
8. RADIATED EMISSION LIMITS	6
9. SYSTEM TEST CONFIGURATION	6
10. TEST PROCEDURE	8
11. EQUIPMENT MODIFICATIONS.....	9
12. TEST RESULT	10
12.1. MAXIMUM MODULATION PERCENTAGE (M%).....	10
12.2. THE EMISSIONS BANDWIDTH	10
APPENDIX 1 TEST CONFIGURATION PHOTOS.....	11
APPENDIX 2 PHOTOGRAPHS OF EUT	16

1. VERIFICATION OF COMPLIANCE

COMPANY NAME : Advance Security Inc.
3F, 48 Ta An Street, Hsi Chih,
Taipei Hsien, Taiwan, R. O. C.

CONTACT PERSON : Michael Chen / President

TELEPHONE NO. : (886-2) 8648-1688

EUT DESCRIPTION : Car Alarm Transceiver

MODEL NAME/NUMBER : TRX86

FCC ID : H5OTR04

DATE TESTED : October 24, 2002 & October 31, 2002

REPORT NUMBER : 02E0505

TYPE OF EQUIPMENT	SECURITY EQUIPMENT (INTENTIONAL RADIATOR)
EQUIPMENT TYPE	433.92 MHz Car Alarm Transceiver
MEASUREMENT PROCEDURE	ANSI 63.4 / 1992
LIMIT TYPE	CERTIFICATION
FCC RULE	CFR 47, PART 15

The above equipment was tested by C&C Laboratory Co., Ltd. for compliance with the requirements set forth in the FCC CFR 47, PART 15. The results of testing in this report apply to the product/system which was tested only. Other similar equipment will not necessarily produce the same results due to production tolerance and measurement uncertainties. **Warning:** This document reports conditions under which testing was conducted and results of tests performed. This document may not be altered or revised in any way unless done so by C&C Laboratory Co., Ltd. and all revisions are duly noted in the revisions section. Any alteration of this document not carried out by C&C Laboratory Co., Ltd. will constitute fraud and shall nullify the document.

Vince Chiang For.

James Chan / Manager
C&C Laboratory Co., Ltd.

2. PRODUCT DESCRIPTION

Fundamental Frequency	433.92 MHz
Power Source	DC 12V
Transmitting Time	Periodic \leq 5 seconds
Associated Receiver	Model: H5OTR03 (FCC ID)

3. TEST FACILITY

The open area test sites and conducted measurement facilities used to collect the radiated data are located at No. 199, Chung Sheng Road, Hsin Tien City, Taipei, Taiwan R.O.C. The sites are constructed in conformance with the requirements of ANSI C63.7, ANSI C63.4 and CISPR Publication 22.

4. MEASUREMENT STANDARDS

The site is constructed and calibrated in conformance with the requirements of ANSI C63.4/1992.

5. TEST METHODOLOGY

For an intentional radiator, the spectrum shall be investigated from the lowest radio frequency signal generated in the device, without going below 9 KHz, up to at least the tenth harmonic of the highest fundamental frequency or to 40 GHz, whichever is lower. (CFR 47 Section 15.33)

6. MEASUREMENT EQUIPMENT USED

Manufacturer	Model Number	Description	Cal Due Date
H.P.	8566B	Spectrum Analyzer (100Hz-22GHz)	06/2003
H.P.	85662A	Spectrum Analyzer (100Hz-22GHz)	06/2003
H.P.	85650A	QUASI-PEAK DETECTOR	06/2003
EMCO	3115	Antenna (1-18GHz)	02/2003
EMCO	3142	Antenna (30-2000MHz)	06/2003
H.P.	8447D A	Amplifier (30-2000MHz)	05/2003
H.P.	8449B	Amplifier (1-26.5GHz)	01/2003

7. POWERLINE RFI LIMIT

CONNECTED TO AC POWER LINE	SECTION 15.207
CARRIER CURRENT SYSTEM IN THE FREQUENCY RANGE OF 450 KHZ TO 30 MHz	SECTION 15.205 AND SECTION 15.209, 15.221, 15.223, 15.225 OR 15.227, AS APPROPRIATE.
BATTERY POWER	NO REQUIRED.

8. RADIATED EMISSION LIMITS

GENERAL REQUIREMENTS	SECTION 15.209
RESTRICTED BANDS OF OPERATION	SECTION 15.205
PERIODIC OPERATION IN THE BAND 40.66 -40.70 MHz AND ABOVE 70 MHz.	SECTION 15.231

9. SYSTEM TEST CONFIGURATION

Use a block of foam and combined it with EUT wrapping rubber band around it. This way it can test X.Y, and Z axis. To activate continuous transmission, place a small plastic block between rubber band and EUT push button.



Radiated Open Site Test Set-up (Transmitter Mode)

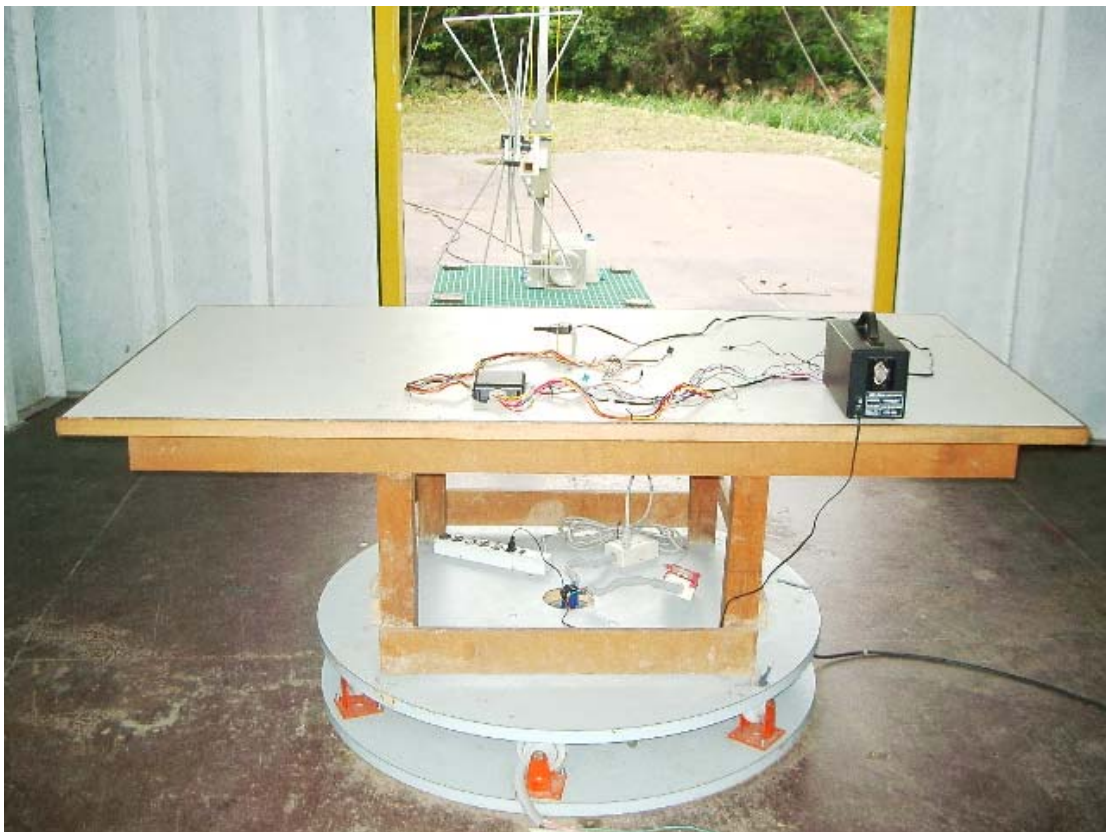

Radiated Open Site Test Set Up (Receiver Mode)

10. TEST PROCEDURE

Radiated Emissions, 15.231(4)(b)

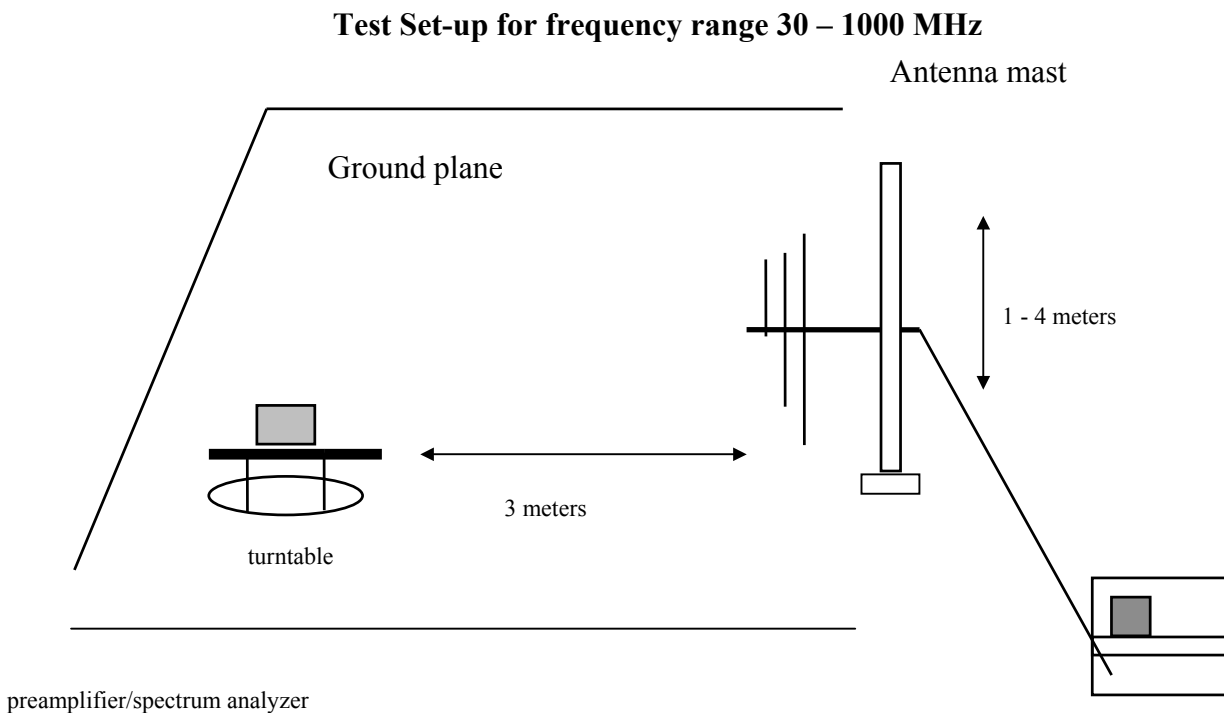

Fig. 1

1. The EUT was placed on a wooden table on the outdoor ground plane. The search antenna was placed 3-meters from the EUT.
2. The turntable was slowly rotated to locate the direction of maximum emission at each emission falling in the restricted bands of 15.205. The EUT was moved throughout the XY, XZ, and YZ planes to maximize emissions received by the search antenna.
3. Once maximum direction was determined, the search antenna was raised and lowered in both vertical and horizontal polarizations. The maximum readings so obtained are recorded in the data listed below.

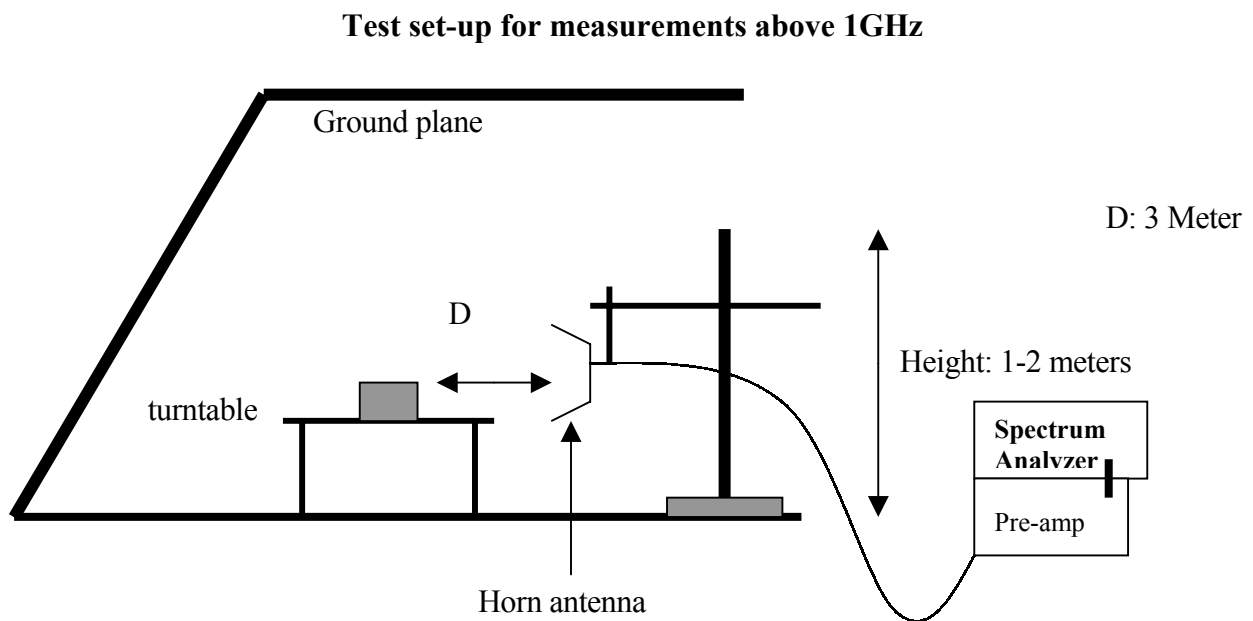

Fig. 2

1. The EUT was placed on a wooden table on the outdoor ground plane. The search antenna was placed 1-meters from the EUT. The EUT antenna was mounted vertically as per normal installation.
2. The turntable was slowly rotated to locate the direction of maximum emission at each emission falling in the restricted bands of 15.205. The EUT was moved throughout the XY, XZ, and YZ planes to maximize emissions received by the search antenna.
3. Once maximum direction was determined, the search antenna was raised and lowered in both vertical and horizontal polarizations. The maximum readings so obtained are recorded in the data listed below.

11. Equipment Modifications

To achieve compliance to FCC Section 15.231 technical limits, the following change(s) were made during compliance testing:

NONE

12. TEST RESULT

Powerline RFI Class B	Eut	Radiated Emission Limits	Eut
SECTION 15.207		SECTION 15.209	X
SECTION 15.205, 15.209, 15.221, 15.223, x 15.225 OR 15.227		SECTION 15.205	
BATTERY POWER	X	SECTION 15.231 (b)	X
		SECTION 15.231 (e)	
		SECTION 15.109	X

12.1 Maximum Modulation Percentage (M%)

CALCULATION: No duty cycle.

Note: Following is the diagram to show the modulation method of the EUT.

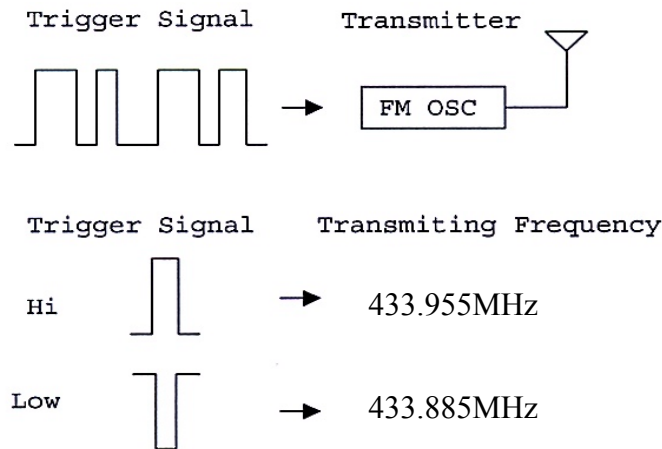

This EUT works as a FM modulation. Signal HI will trigger FM OSC to generate a 433.955 MHz frequency and signal LOW will trigger FM OSC to generate a 433.885 MHz frequency. It is only 0.07 MHz deviation, so that there is no duty cycle on it.

12.2 The Emissions Bandwidth

The bandwidth of the emissions were investigated per 15.231(c)

Center Frequency	Measured	Limits
433.92 MHz	444.4 kHz < (refer to plot)	433.92MHzX0.25%=1084.8 kHz



Date 11.Oct.'02 Time 11:50:51

Ref.Lvl 80.00 dB μ V
Delta 0.15 dB
444.4 kHz

Res.Bw 120 kHz [imp]
TG.Lvl off
CF.Stp 200.000 kHz
NOT CALIBRATED

Vid.Bw 300 kHz
RF.Att 10 dB
Unit [dB μ V]

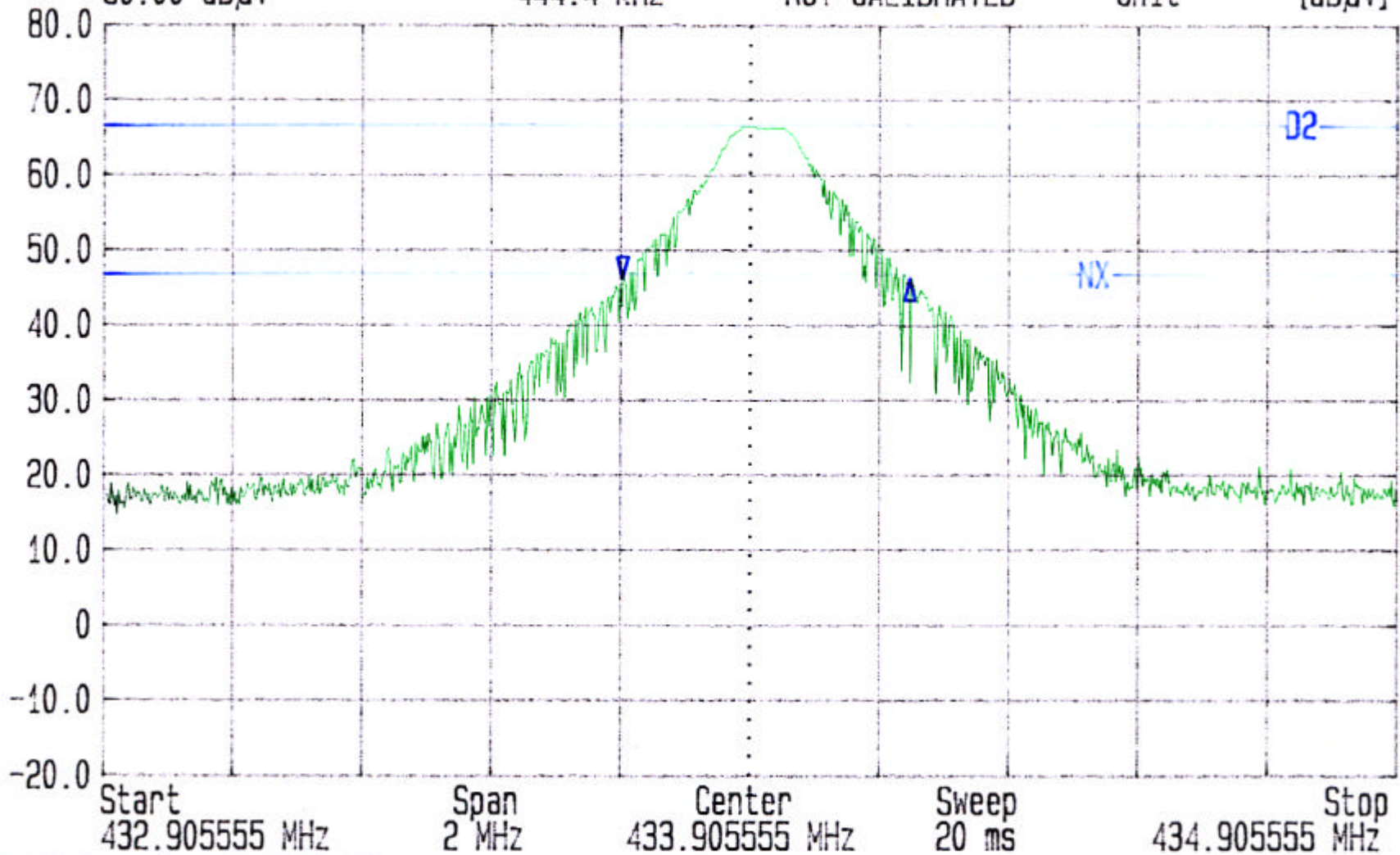

N dB down Level 20.0 dB
DELTA MARK 444.4 KHz

C&C Laboratory CO., LTD.

FCC, VCCI, CISPR, CE, AUSTEL, NZ
UL, CSA, TUV, BSMI, DHHS, NVLAP

No. 199 Chung Sheng Road
Hsin Tien City, Taipei, Taiwan, R.O.C.
PHONE: 02-2217-0894 FAX: 02-2217-1254

Project #: 02E0505
Report #: 0505E1
Date & Time: 2002/10/28
Test Engr: DAVID HUNG

Company: Advance Security Inc.
EUT Description: TRX86 (433.92 MHz / TRANSCEIVER)
Test Configuration : EUT / DC POWER
Type of Test: FCC 15.231(b)
Mode of Operation: TRANSMITTER MODE

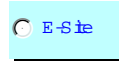

$$M\% = ((t1+t2+t3+...)/T) * 100\% = 100 \quad \%$$

$$Av \text{ Reading} = Pk \text{ Reading} + 20 * \log(M\%)$$

$$20 * \log(M\%) = 0$$

	Freq. (MHz)	Pk Rdg (dBuV)	Av Rdg (dBuV)	AF (dB)	Closs (dB)	Pre-amp (dB)	Level (dBuV/m)	Limit FCC_B	Margin (dB)	Pol (H/V)	Az (Deg)	Height (Meter)
	Button #:											
X	433.95	43.10	43.10	17.43	3.21	26.33	37.41	80.83	-43.42	3mV	180	1.00
	867.87	33.10	33.10	24.81	4.75	26.31	36.35	60.83	-24.48	3mV	180	1.20
Y	433.89	46.40	46.40	17.43	3.21	26.33	40.71	80.83	-40.12	3mV	90	1.30
	867.81	34.10	34.10	24.81	4.75	26.31	37.35	60.83	-23.48	3mV	90	1.00
Z	433.96	46.50	46.50	17.43	3.21	26.33	40.81	80.83	-40.02	3mV	0	1.00
	867.80	32.70	32.70	24.81	4.75	26.31	35.95	60.83	-24.88	3mV	0	1.50
X	433.95	49.00	49.00	17.43	3.21	26.33	43.31	80.83	-37.52	3mH	0	1.00
	867.80	33.90	33.90	24.81	4.75	26.31	37.15	60.83	-23.68	3mH	0	1.10
Y	433.90	48.00	48.00	17.43	3.21	26.33	42.31	80.83	-38.52	3mH	270	1.00
	867.81	33.80	33.80	24.81	4.75	26.31	37.05	60.83	-23.78	3mH	270	1.10
Z	433.91	46.10	46.10	17.43	3.21	26.33	40.41	80.83	-40.42	3mH	90	1.00
	867.90	33.40	33.40	24.81	4.75	26.31	36.65	60.83	-24.18	3mH	90	1.30

Peak: RBW= 120KHz
VBW= 300KHz
A(Average): PkReading - 0dB

Total Data #12

C&C Laboratory CO., LTD.

FCC, VCCI, CISPR, CE, AUSTEL, NZ
UL, CSA, TUV, BSMI, DHHS, NVLAP

No. 199 Chung Sheng Road
Hsin Tien City, Taipei, Taiwan, R.O.C.
PHONE: 02-2217-0894 FAX: 02-2217-1254

Project #: 02E0505
Report #: 0505E2
Date & Time: 2002/10/24
Test Engr: DAVID HUNG

Company: Advance Security Inc.
EUT Description: TRX86 (433.92 MHz / TRANSCEIVER)
Test Configuration : EUT / DC POWER
Type of Test: FCC 15.231(b) / FCC 15.209
Mode of Operation: TRANSMITTER MODE

E-Stat

Freq.	Pk Rdg	Av Rdg	AF	Closs	Pre-amp	Level	Limit	Margin	Pol	Az	Height	Mark
(MHz)	(dBuV)	(dBuV)	(dB)	(dB)	(dB)	(dBuV/m)	FCC_B	(dB)	(H/V)	(Deg)	(Meter)	(P/Q/A)
1302	53.08	53.08	24.88	3.59	37.07	44.48	54.0	-9.52	3mV	0	1.0	A
1736	51.08	51.08	26.37	4.44	36.47	45.42	60.8	-15.38	3mV	0	1.0	A
2170	51.68	51.68	27.75	4.47	36.06	47.84	60.8	-12.96	3mV	60	1.0	A
2603	50.25	50.25	28.82	5.64	36.02	48.69	60.8	-12.11	3mV	60	1.0	A
3037	49.69	49.69	30.38	5.81	36.06	52.15	60.8	-8.65	3mV	90	1.0	A
3471	48.69	48.69	31.26	6.13	35.64	50.44	60.8	-10.36	3mV	150	1.0	A
3905	45.83	45.83	32.30	6.68	35.21	49.60	54.0	-4.40	3mV	240	1.0	A
4340	46.33	46.33	32.36	7.15	35.17	50.67	54.0	-3.33	3mV	240	1.0	A
1302	54.96	54.96	24.88	3.59	37.07	46.36	54.0	-7.64	3mH	240	1.0	A
1736	49.70	49.70	26.37	4.44	36.47	44.04	60.8	-16.76	3mH	0	1.0	A
2170	49.41	49.41	27.75	4.47	36.06	45.57	60.8	-15.23	3mH	0	1.0	A
2603	50.23	50.23	28.82	5.64	36.02	48.67	60.8	-12.13	3mH	60	1.0	A
3038	47.96	47.96	30.38	5.81	36.06	52.15	60.8	-8.65	3mH	60	1.0	A
3471	49.67	49.67	31.26	6.13	35.64	51.42	60.8	-9.38	3mH	90	1.0	A
3905	47.50	47.50	32.30	6.68	35.21	51.27	54.0	-2.73	3mH	150	1.0	A
4339	46.92	46.92	32.36	7.15	35.17	51.26	54.0	-2.74	3mH	150	1.0	A

* No other emission were found within 20dB under the limits upto 4.5 GHz.

Total data #16
V.2d

P(Peak): RBW=VBW=1MHz
A(Average): Pk Reading - 0dB (For FCC 15.231(b))

Data#: 16 File#: 0505e.emi

Date: 2002-10-31 Time: 10:31:20

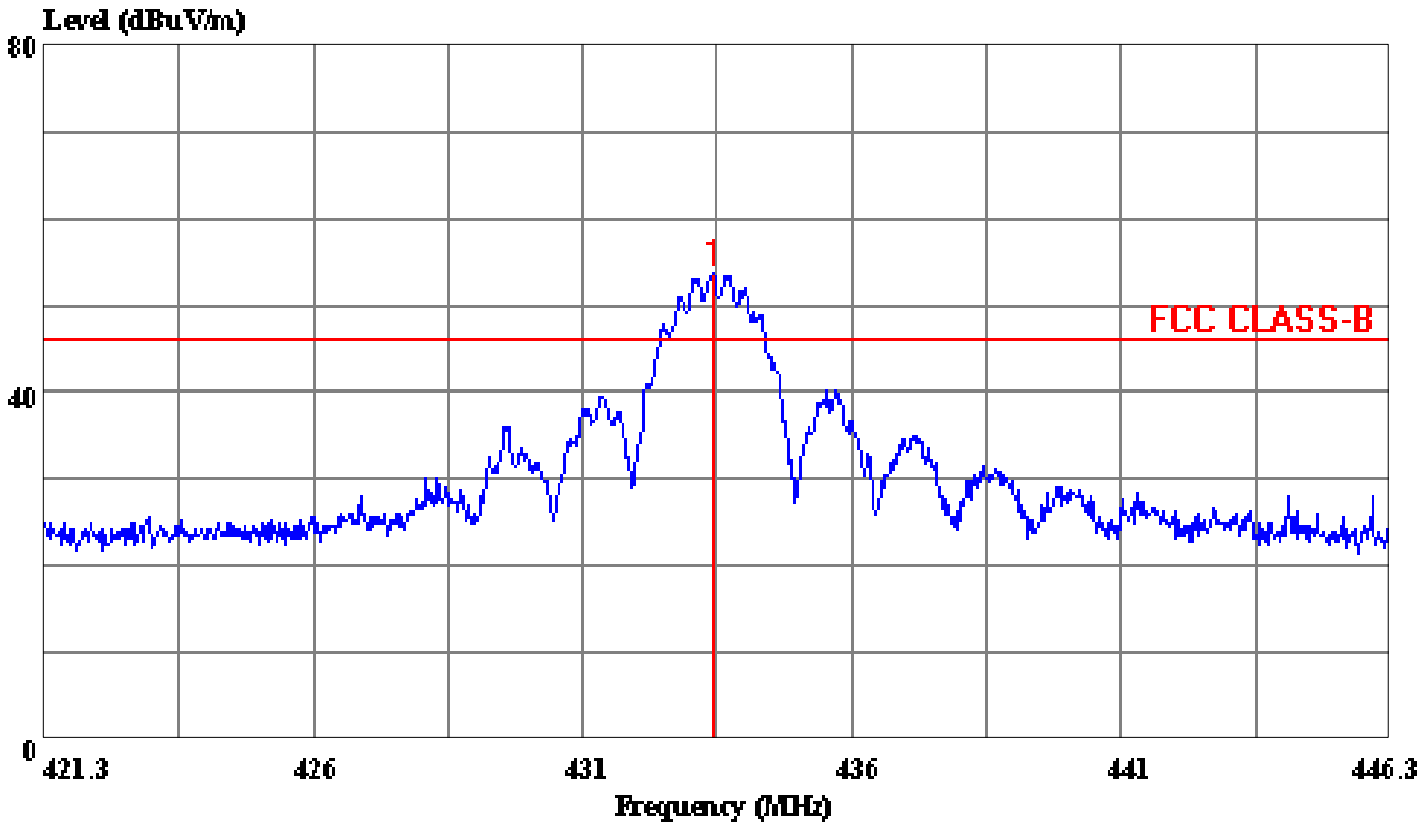

(E-Site)

Trace: 13

Ref Trace:

Condition: VERTICAL
 Report No. : 02E0505
 Test Engr. : DAVID HUNG
 Company : Advance Security Inc.
 EUT : TRX86
 Test Config : EUT /DC POWER /TX
 Type of Test: FCC 15.109
 Mode of Op. : RECEIVER MODE (Model No. TRX851DV transmit signal and trigger EUT to product signal)

Page: 1

	Read
Freq	Level
MHz	dBuV
1 * 433.725	59.40

Data#: 17 File#: 0505e.emi

Date: 2002-10-31 Time: 10:32:08

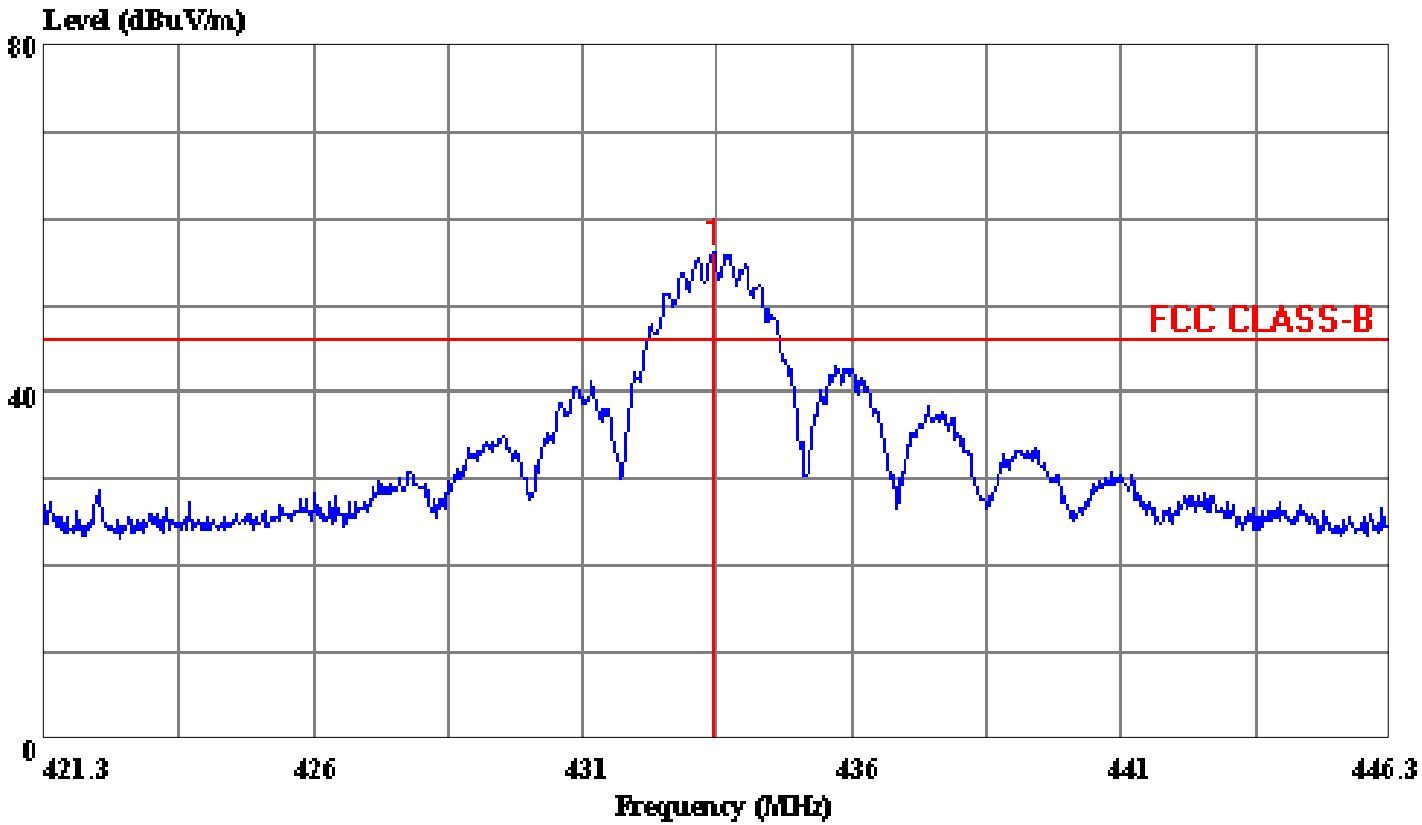

(E- Site)

Trace: 14

Ref Trace:

Condition: HORIZONTAL
 Report No. : 02E0505
 Test Engr. : DAVID HUNG
 Company : Advance Security Inc.
 EUT : TRX86
 Test Config : EUT /DC POWER /TX
 Type of Test: FCC 15.109
 Mode of Op. : RECEIVER MODE (Model No. TRX851DV transmit signal and trigger EUT to product signal)

Page: 1

	Read
Freq	Level
MHz	dBuV
1 *	433.725 61.80

Data#: 15 File#: 0505e.emi

Date: 2002-10-31 Time: 10:31:09

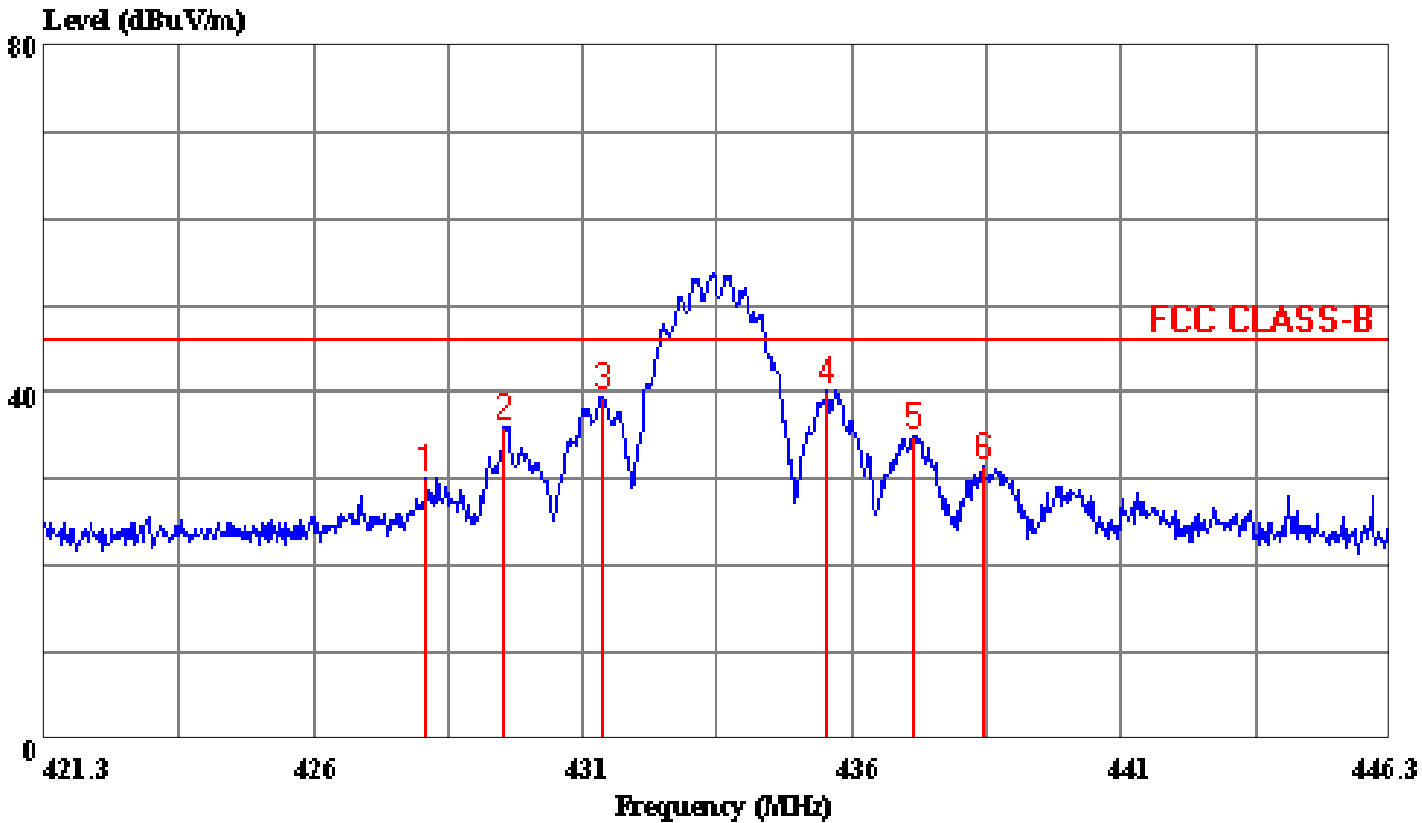

(E-Site)

Trace: 13

Ref Trace:

Condition: VERTICAL
Report No. : 02E0505
Test Engr. : DAVID HUNG
Company : Advance Security Inc.
EUT : TRX86
Test Config : EUT /DC POWER /TX
Type of Test: FCC 15.109
Mode of Op. : RECEIVER MODE (Model No. TRX851DV transmit signal and trigger EUT to product signal)

Page: 1

	Read Freq	Probe Level	Probe Factor	Cable Loss	Preamplifier Factor	Level	Limit Line	Over Limit	Remark
	MHz	dBuV	dB	dB	dB	dBuV/m	dBuV/m	dB	
1	428.400	35.60	17.52	3.19	26.31	30.00	46.00	-16.00	Peak
2	429.850	41.70	17.49	3.20	26.32	36.07	46.00	-9.93	Peak
3	431.675	45.30	17.45	3.20	26.32	39.63	46.00	-6.37	Peak
4	435.800	45.90	17.37	3.21	26.34	40.15	46.00	-5.85	Peak
5	437.450	40.70	17.34	3.22	26.34	34.91	46.00	-11.09	Peak
6	438.725	37.20	17.31	3.22	26.35	31.39	46.00	-14.61	Peak

Data#: 18 File#: 0505e.emi

Date: 2002-10-31 Time: 10:33:32

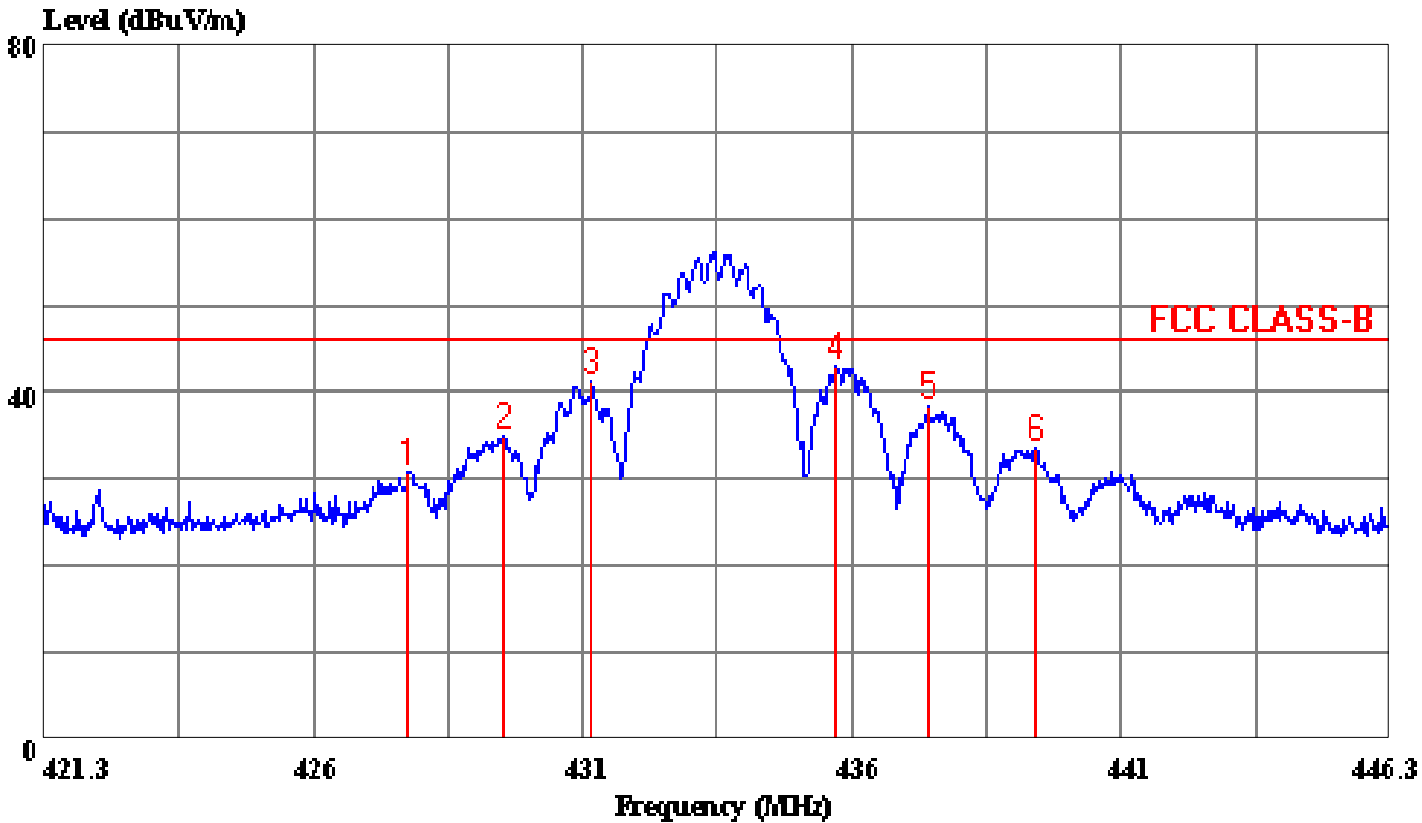

(E- Site)

Trace: 14

Ref Trace:

Condition: HORIZONTAL
Report No. : 02E0505
Test Engr. : DAVID HUNG
Company : Advance Security Inc.
EUT : TRX86
Test Config : EUT /DC POWER /TX
Type of Test: FCC 15.109
Mode of Op. : RECEIVER MODE (Model No. TRX851DV transmit signal and trigger EUT to product signal)

Page: 1

	Read Freq	Probe Level	Probe Factor	Cable Loss	Preamplifier Factor	Level	Limit Line	Over Limit	Remark
	MHz	dBuV	dB	dB	dB	dBuV/m	dBuV/m	dB	
1	428.075	36.50	17.53	3.19	26.31	30.91	46.00	-15.09	Peak
2	429.825	40.60	17.49	3.20	26.31	34.97	46.00	-11.03	Peak
3	431.475	46.80	17.46	3.20	26.32	41.14	46.00	-4.86	Peak
4	436.000	48.70	17.37	3.21	26.34	42.94	46.00	-3.06	Peak
5	437.700	44.20	17.34	3.22	26.35	38.41	46.00	-7.59	Peak
6	439.725	39.30	17.30	3.22	26.35	33.47	46.00	-12.53	Peak

Data#: 19 File#: 0505e.emi

Date: 2002-10-31 Time: 10:35:21

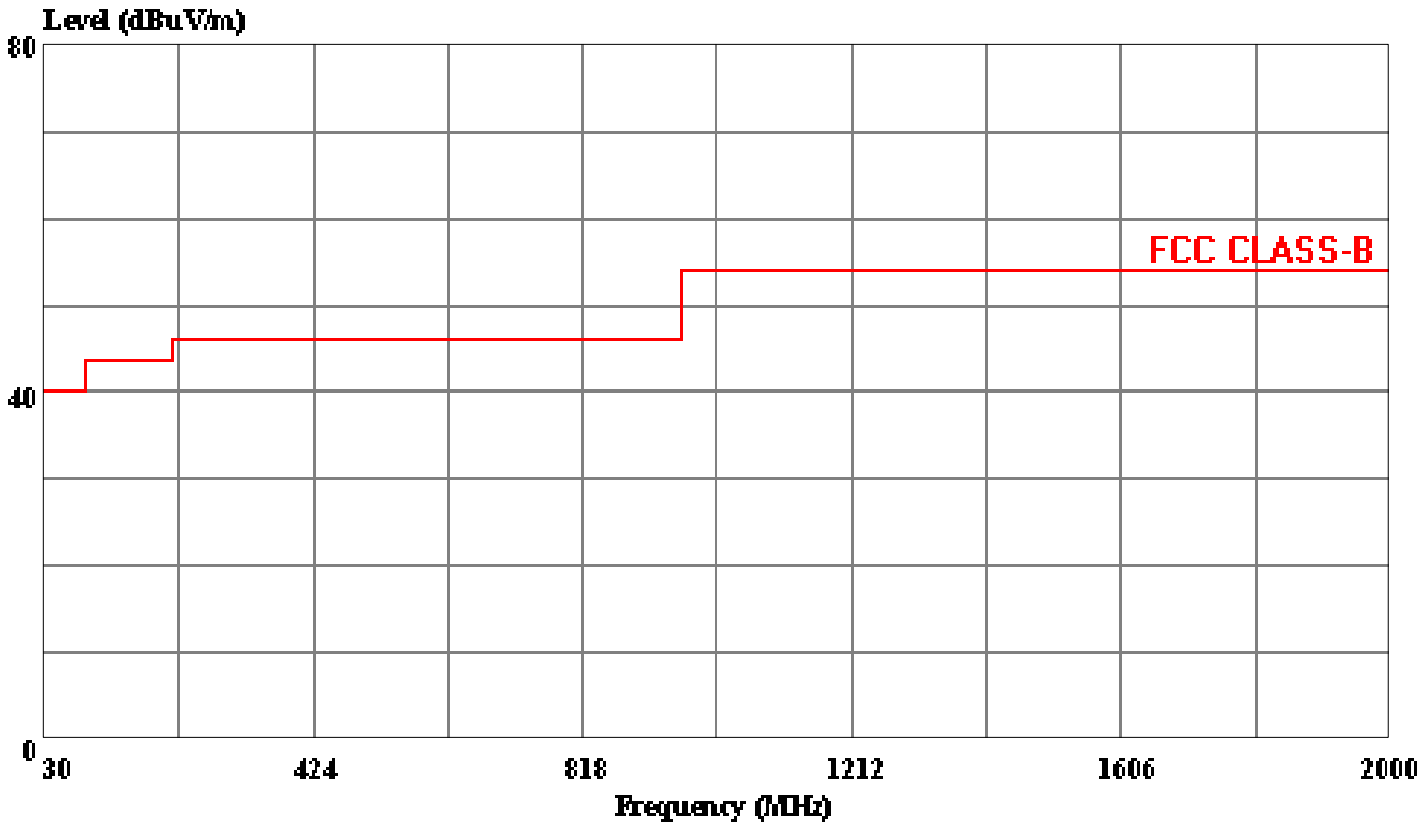

(E-Site)

Trace:

Ref Trace:

Condition:
 Report No. : 02E0505
 Test Engr. : DAVID HUNG
 Company : Advance Security Inc.
 EUT : TRX86
 Test Config : EUT /DC POWER /TX
 Type of Test: FCC 15.109
 Mode of Op. : RECEIVER MODE
 : NO OTHER EMISSION WERE FOUND WITHIN
 : 20 dB BELOW THE LIMITS FROM 30-2000MHZ