

**KTL Test Report:** 9R02216

**Applicant:** Daniels Electronics Ltd.  
43 Erie Street  
Victoria, BC  
V8V 1P8

**Equipment Under Test:  
(E.U.T.)** Transmitter (VT-3A130)

**In Accordance With:** **FCC Part 87, Subpart D**

**Tested By:** KTL Ottawa Inc.  
3325 River Road, R.R. 5  
Ottawa, Ontario K1V 1H2

**Authorized By:**

R. Grant, Wireless Group Manager

**Date:**

**Total Number of Pages:** 25

*EQUIPMENT: Transmitter (VT-3A130)*

---

## **Table of Contents**

<b>Section 1.</b>	<b>Summary of Test Results.....</b>	<b>3</b>
<b>Section 2.</b>	<b>General Equipment Specification .....</b>	<b>5</b>
<b>Section 3.</b>	<b>RF Power Output .....</b>	<b>6</b>
<b>Section 4.</b>	<b>Audio Frequency Response .....</b>	<b>7</b>
<b>Section 5.</b>	<b>Modulation Limiting.....</b>	<b>8</b>
<b>Section 6.</b>	<b>Occupied Bandwidth.....</b>	<b>10</b>
<b>Section 7.</b>	<b>Spurious Emissions at Antenna Terminals.....</b>	<b>13</b>
<b>Section 9.</b>	<b>Field Strength of Spurious Emissions .....</b>	<b>16</b>
<b>Section 9.</b>	<b>Frequency Stability .....</b>	<b>18</b>
<b>Section 10.</b>	<b>Test Equipment List .....</b>	<b>21</b>
<b>Annex A</b>	<b>Test Diagrams .....</b>	<b>A1</b>

*EQUIPMENT: Transmitter (VT-3A130)*

---

## **Section 1. Summary of Test Results**

### **General**

**All measurements are traceable to national standards.**

Manufacturer: Daniels Electronics Ltd.

Model No.: VT-3A130

Serial No.: 50001

Date Received In Laboratory: March 20, 2000

KTL Identification No.: Item #4

These tests were conducted on a sample of the equipment for the purpose of demonstrating compliance with FCC Part 87, Subpart D.

New Submission  
Class II Permissive Change

Production Unit  
Pre-Production Unit

T	N	B
---	---	---

Equipment Code

THIS TEST REPORT RELATES ONLY TO THE ITEM(S) TESTED.

THE FOLLOWING DEVIATIONS FROM, ADDITIONS TO, OR EXCLUSIONS FROM THE TEST SPECIFICATIONS HAVE BEEN MADE.

See "Summary of Test Data".



**NVLAP LAB CODE: 100351-0**

TESTED BY: \_\_\_\_\_ DATE: \_\_\_\_\_  
Glen Westwell, Technologist

KTL Ottawa Inc. authorizes the above named company to reproduce this report provided it is reproduced in its entirety and for use by the company's employees only.

Any use which a third party makes of this report, or any reliance on or decisions to be made based on it, are the responsibility of such third parties. KTL Ottawa Inc. accepts no responsibility for damages, if any, suffered by any third party as a result of decisions made or actions based on this report. This report applies only to the items tested.

*EQUIPMENT: Transmitter (VT-3A130)*

---

**Summary Of Test Data**

<b>Name Of Test</b>	<b>Para. No.</b>	<b>Result</b>
RF Power Output	87.131	Complies
Audio Frequency Response	2.1047	Complies
Audio Low-Pass Filter Response	2.1047	Not Applicable
Modulation Limiting	87.141	Complies
Occupied Bandwidth	87.139	Complies
Spurious Emissions at Antenna Terminals	87.139	Complies
Field Strength of Spurious Emissions	87.139	Complies
Frequency Stability	87.133	Complies

**Footnotes For N/A's:**

This equipment does not have an audio low pass filter.

**Test Conditions:**

**Indoor**

Temperature: 24 °C

Humidity: 12 %

**Outdoor**

Temperature: 15 °C

Humidity: 10 %

*EQUIPMENT: Transmitter (VT-3A130)*

---

## **Section 2.        General Equipment Specification**

### **Transmitter**

<b>Supply Voltage Input:</b>	13.8 Vdc
<b>Frequency Range:</b>	118 to 136.975 MHz
<b>Tunable Bands:</b>	1
<b>Necessary Bandwidth:</b>	6 kHz
<b>Types of Modulation:</b>	Amplitude Modulation Full Carrier Double Sideband
<b>Data Rate(s)</b>	Not Applicable
<b>Internal/External Data Source:</b>	Not Applicable
<b>Emission Designator:</b>	6K00A3E
<b>Output Impedance:</b>	50 ohms
<b>RF Power Output (rated):</b>	1 to 4 W
<b>Duty Cycle:</b>	Continuous
<b>Channel Spacing(s):</b>	25 kHz
<b>Operator Selection of Operating Frequency:</b>	Preprogrammed Frequencies via Front Panel
<b>Power Output Adjustment Capability:</b>	Internal

*EQUIPMENT: Transmitter (VT-3A130)*

---

**Section 3. RF Power Output**

**Para. No.: 2.1046**

<b>Test Performed By:</b> Glen Westwell	<b>Date of Test:</b> March 22, 2000
---	-------------------------------------

**Minimum Standard:** Para No. 87.131  
50W

**Test Results:** Complies.  
The maximum output power is 7.1W. This is 8.5 dB below the specification limit.

**Measurement Data:** Transmitter – 128 MHz  
4.4W Unmodulated  
7.1W Modulated with 2500 Hz Tone@16dB overdrive relative to 50% Modulation resulting in 90.4% Modulation  
1.2W Unmodulated  
2.0W Modulated 2500 Hz Tone 90.8% Modulation

EQUIPMENT: Transmitter (VT-3A130)

---

## Section 4. Audio Frequency Response

Para. No.: 2.1047

Test Performed By: Glen Westwell	Date of Test: March 22, 2000
----------------------------------	------------------------------

Test Results: Complies.

Measurement Data:

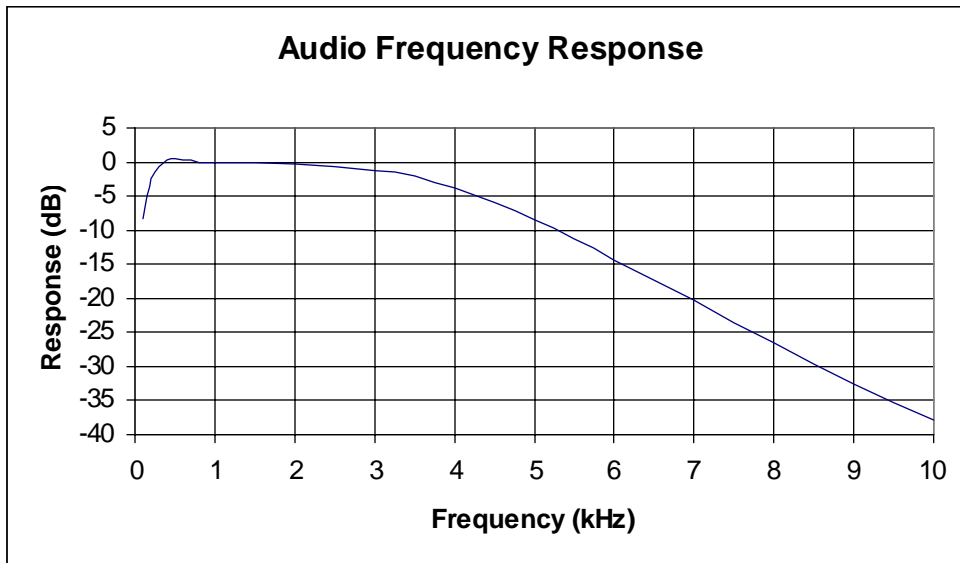

*EQUIPMENT: Transmitter (VT-3A130)*

---

**Section 5. Modulation Limiting**

**Para. No.: 2.1047**

<b>Test Performed By:</b> Glen Westwell	<b>Date of Test:</b> March 22, 2000
---	-------------------------------------

**Minimum Standard:** Para No. 141(a)  
100%

**Test Results:** Complies.

**Measurement Data:** See attached graph.



EQUIPMENT: Transmitter (VT-3A130)

---

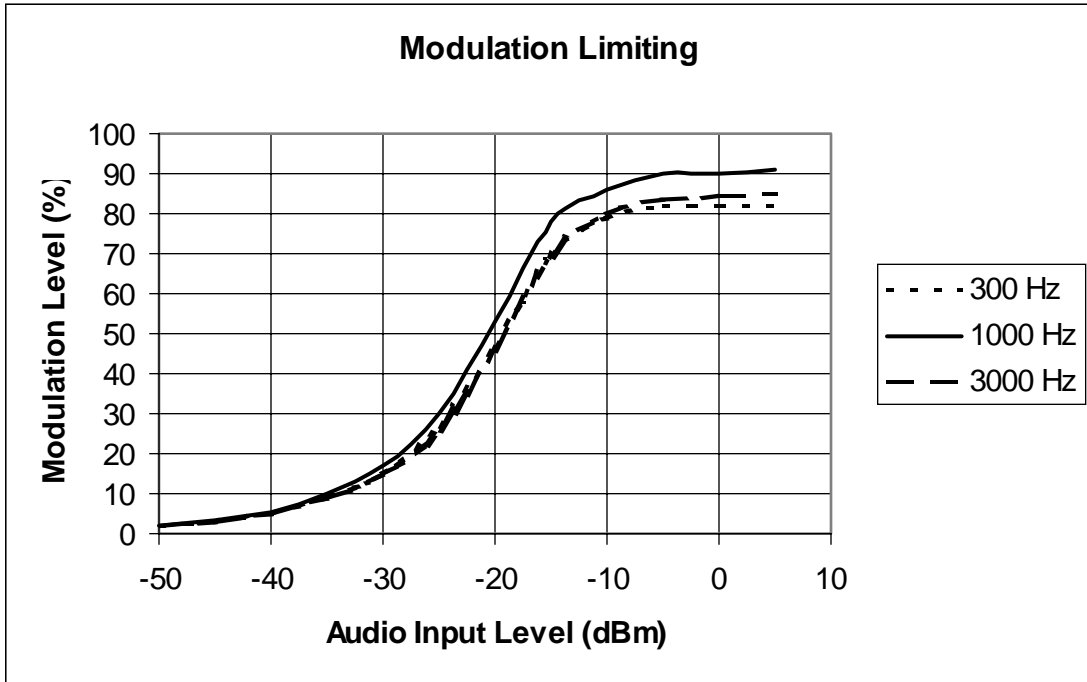

*EQUIPMENT: Transmitter (VT-3A130)*

---

**Section 6. Occupied Bandwidth**

**Para. No.: 2.1047**

<b>Test Performed By:</b> Glen Westwell	<b>Date of Test:</b> March 22, 2000
---	-------------------------------------

**Minimum Standard:** 87.139(a)

**Test Results:** Complies.

**Test Data:** See attached graph(s).

EQUIPMENT: Transmitter (VT-3A130)

---

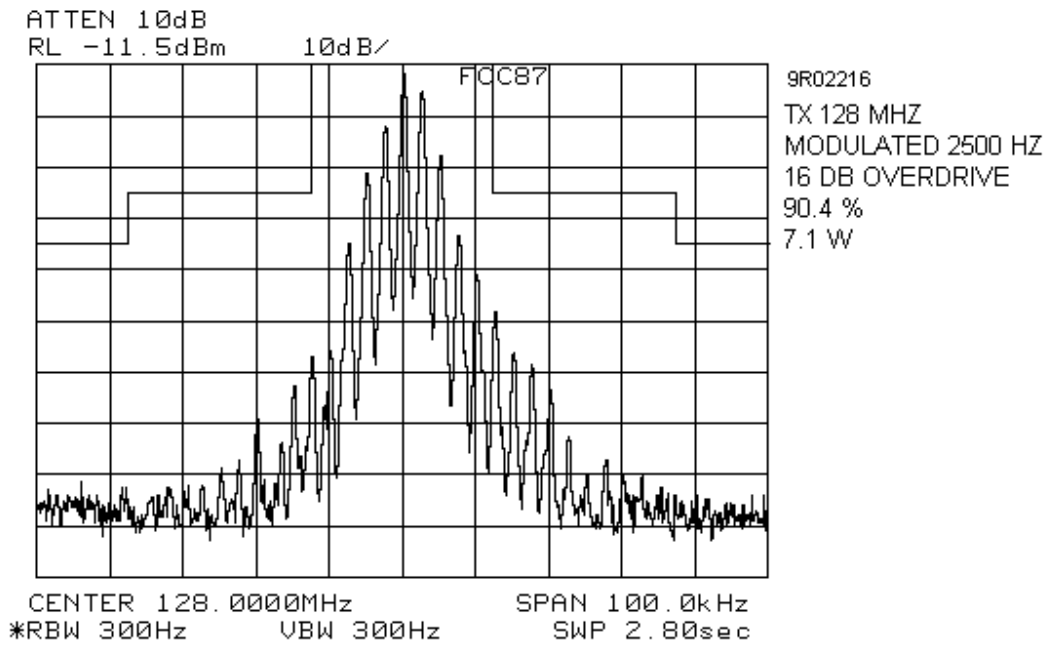

EQUIPMENT: Transmitter (VT-3A130)

---

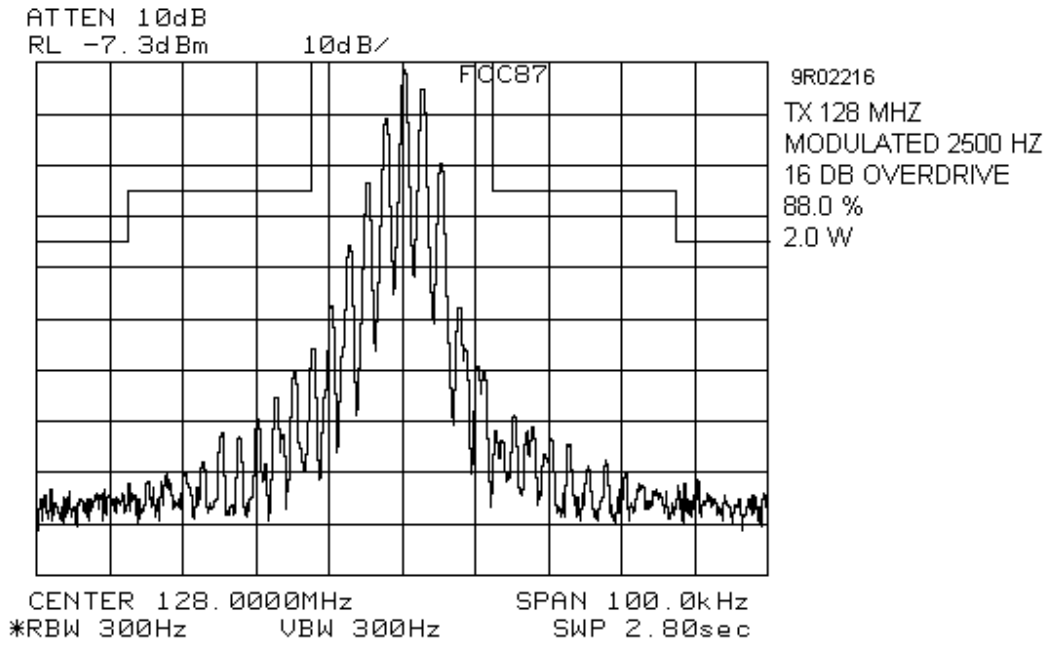

*EQUIPMENT: Transmitter (VT-3A130)*

---

**Section 7. Spurious Emissions at Antenna Terminals**

**Para. No.: 2.1051**

<b>Test Performed By:</b> Glen Westwell	<b>Date of Test:</b> March 22, 2000
---	-------------------------------------

**Minimum Standard:** 87.139(a)

**Test Results:** Complies.

**Test Data:** See attached graph(s).

EQUIPMENT: Transmitter (VT-3A130)

---

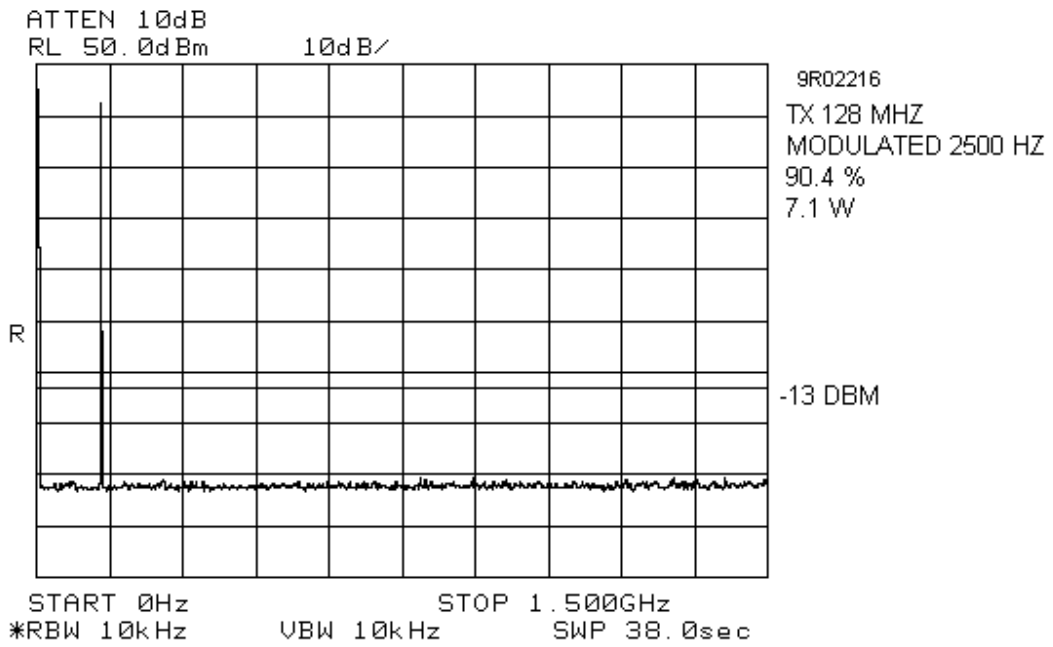

EQUIPMENT: Transmitter (VT-3A130)

---

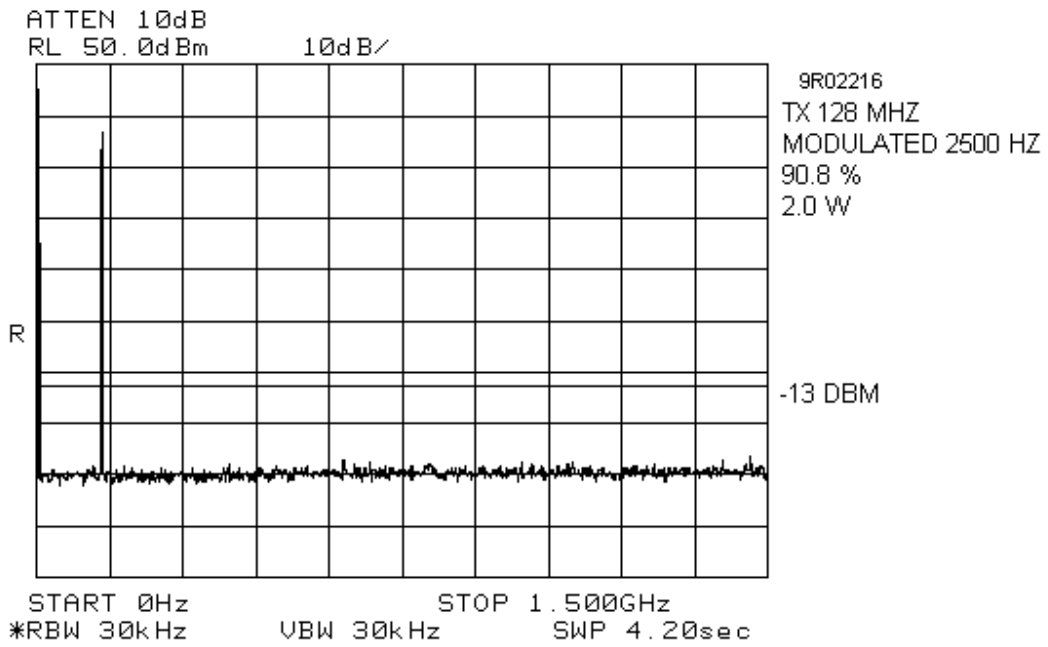

*EQUIPMENT: Transmitter (VT-3A130)*

---

**Section 9. Field Strength of Spurious Emissions**

**Para. No.: 2.1053**

<b>Test Performed By:</b> Glen Westwell	<b>Date of Test:</b> March 23, 2000
---	-------------------------------------

**Minimum Standard:** 87.139(a)  
-13 dBm

**Test Results:** Complies.

No emissions were detected within 20dB of the specification limit on the outdoor range at a distance of 3m.

**Test Data:** See attached graph(s).



*EQUIPMENT: Transmitter (VT-3A130)*

---

**Photographs of Test Setup**

**Front View**

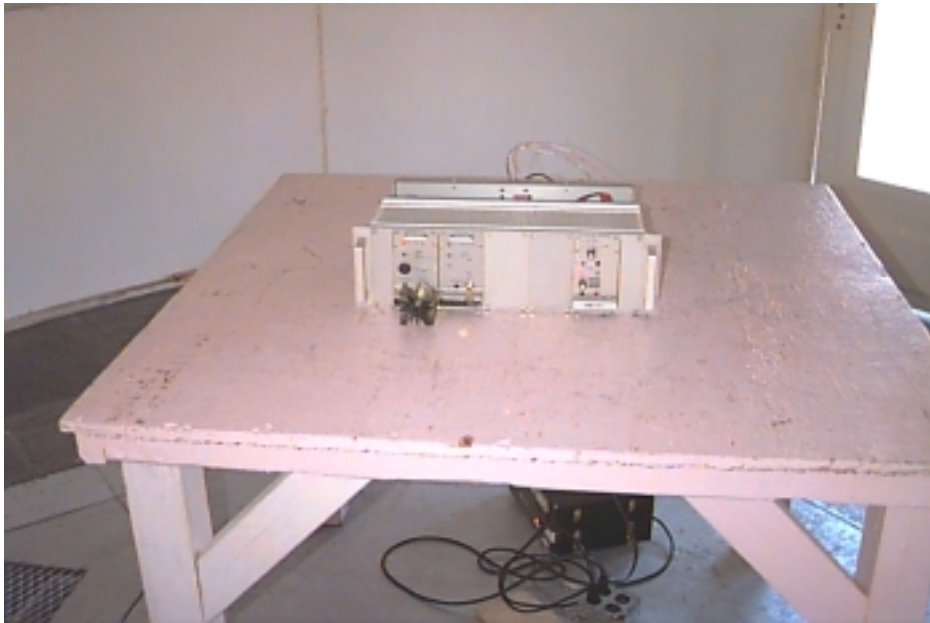

**Rear View**



*EQUIPMENT: Transmitter (VT-3A130)*

---

**Section 9.        Frequency Stability**

**Para. No.: 2.1055**

<b>Test Performed By:</b> Glen Westwell	<b>Date of Test:</b> March 23, 2000
---	-------------------------------------

**Minimum Standard:**        87.133(a)  
   20 ppm

**Test Results:**                Complies.

**Test Data:**                    See attached graph(s).  
  
   The maximum frequency drift is 55 Hz.  
   This is 0.430 ppm.

EQUIPMENT: Transmitter (VT-3A130)

**Frequency Stability – Transmitter 128.000 MHz, STV 13.8 Vdc**

Time (min)	Frequency (MHz)				
	-30°C	-20°C	-10°C	0°C	10°C
0.0	127.999954	127.999962	127.999966	127.999984	127.999989
1.0	127.999952	127.999956	127.999966	127.999985	127.999991
2.0	127.999952	127.999957	127.999968	127.999985	127.999991
3.0	127.999945	127.999958	127.999969	127.999985	127.999991
4.0	127.999945	127.999958	127.999970	127.999986	127.999992
5.0	127.999949	127.999958	127.999971	127.999986	127.999992

Time (min)	Frequency (MHz)			
	20°C	30°C	40°C	50°C
0.0	127.999988	127.999969	128.000047	127.999984
1.0	127.999990	127.999970	128.000045	127.999986
2.0	127.999990	127.999969	128.000036	127.999989
3.0	127.999989	127.999968	128.000030	127.999990
4.0	127.999988	127.999967	128.000020	127.999991
5.0	127.999988	127.999965	128.000014	127.999991

Test Condition	Frequency Drift Hz
-30°C	-55
-20°C	-44
-10°C	-34
0°C	-16
10°C	-11
20°C	-39
30°C	-35
40°C	+47
50°C	-16

*EQUIPMENT: Transmitter (VT-3A130)*

---

**Voltage Variations**

<b>Time (min)</b>	<b>Ambient Start</b>		
	<b>85% STV</b>	<b>STV 13.8V</b>	<b>115% STV</b>
0.0	127.999961	127.999961	127.999962
1.0	127.999961	127.999961	127.999962
2.0	127.999961	127.999961	127.999962
3.0	127.999961	127.999961	127.999962
4.0	127.999961	127.999961	127.999962
5.0	127.999961	127.999961	127.999962

<b>Voltage</b>	<b>Frequency Drift Hz</b>
85% STV	-39
115% STV	-38

*EQUIPMENT: Transmitter (VT-3A130)*

---

**Section 10. Test Equipment List**

<b>CAL CYCLE</b>	<b>EQUIPMENT</b>	<b>MANUFACTURER</b>	<b>MODEL</b>	<b>SERIAL</b>	<b>LAST CAL.</b>	<b>NEXT CAL.</b>
1 Year	Spectrum Analyzer	Hewlett Packard	8565E	FA000981	June 16/99	June 16/00
1 Year	Radio Communications	Rohde & Schwarz	CMTA 54	840343/013	Dec. 14/99	Dec. 14/00
1 Year	Climate Chamber	Thermotron	SM-16C	15649-S	COU	COU
	Power Supply	Astron	VS-50M	8405071	NCR	NCR
1 Year	Attenuator	Narda	768-20	9507	Oct. 12/99	Oct. 12/00
1 Year	Attenuator	Narda	768-10	9709	Oct. 8/99	Oct. 8/00
1 Year	Attenuator	Narda	769-20	4153	Oct. 1/99	Oct. 1/00
1 Year	Horn Antenna	EMCO #2	3115	4336	Nov. 11/99	Nov. 11/00
1 Year	Log Periodic Antenna 1	EMCO	LPA-25	1141	Aug. 4/99	Aug. 4/00
1 Year	Biconical (1) Antenna	EMCO	3109	9204-2708	Aug. 4/99	Aug. 4/00
1 Year	Power Meter	Hewlett Packard	E4418B	1416	Dec. 7/99	Dec. 7/00
1 Year	Power Sensor	Hewlett Packard	8487A	1419	Dec. 7/99	Dec. 7/00

NA: Not Applicable  
 NCR: No Cal Required  
 COU: CAL On Use

*EQUIPMENT: Transmitter (VT-3A130)*

---

**Annex A**  
**Test Diagrams**

EQUIPMENT: Transmitter (VT-3A130)

---

**Para. No. 2.1046 - R.F. Power Output**

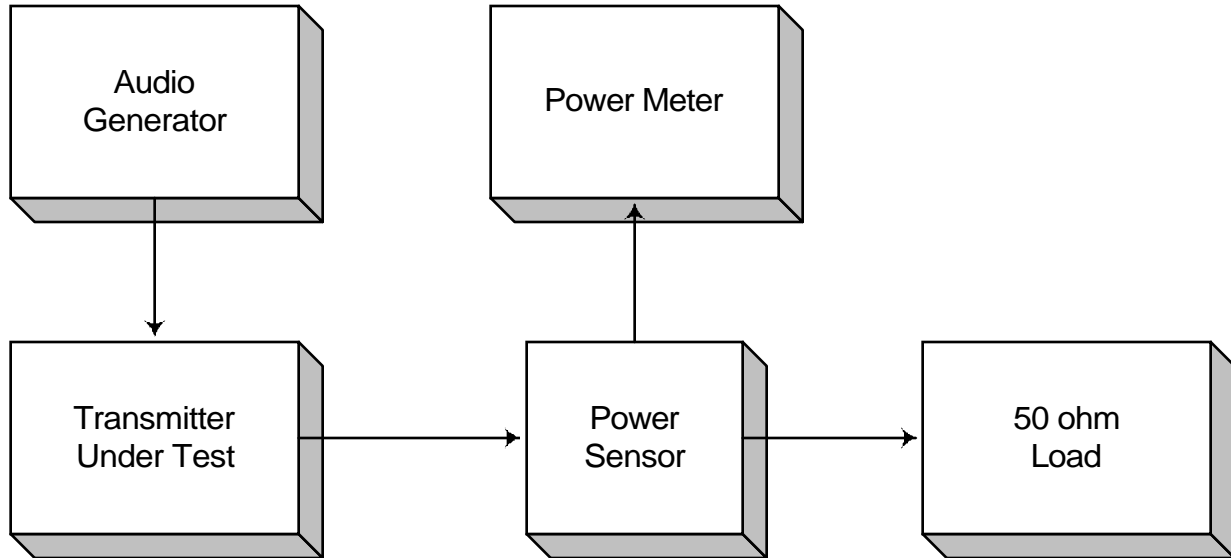

**Para. No. 2.1047(a) - Audio Frequency Response**

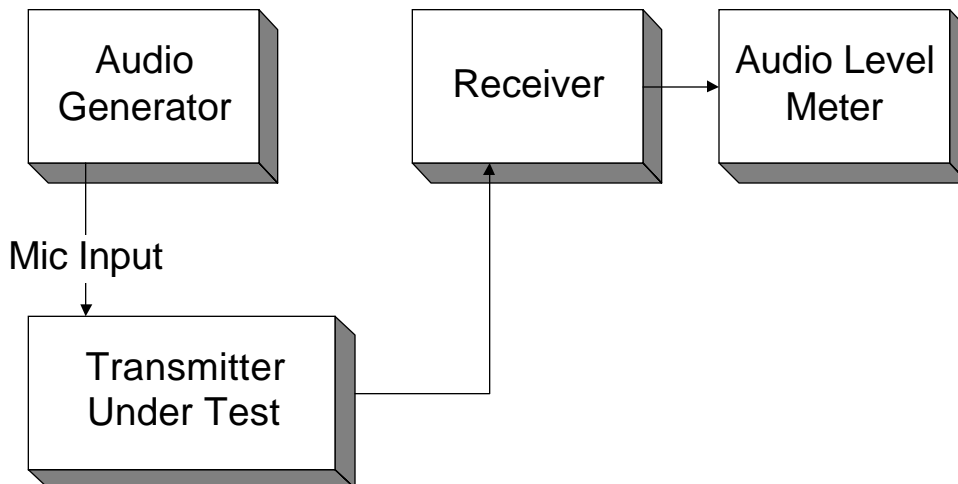

EQUIPMENT: Transmitter (VT-3A130)

---

**Para. No. 2.1047(b) - Modulation Limiting**

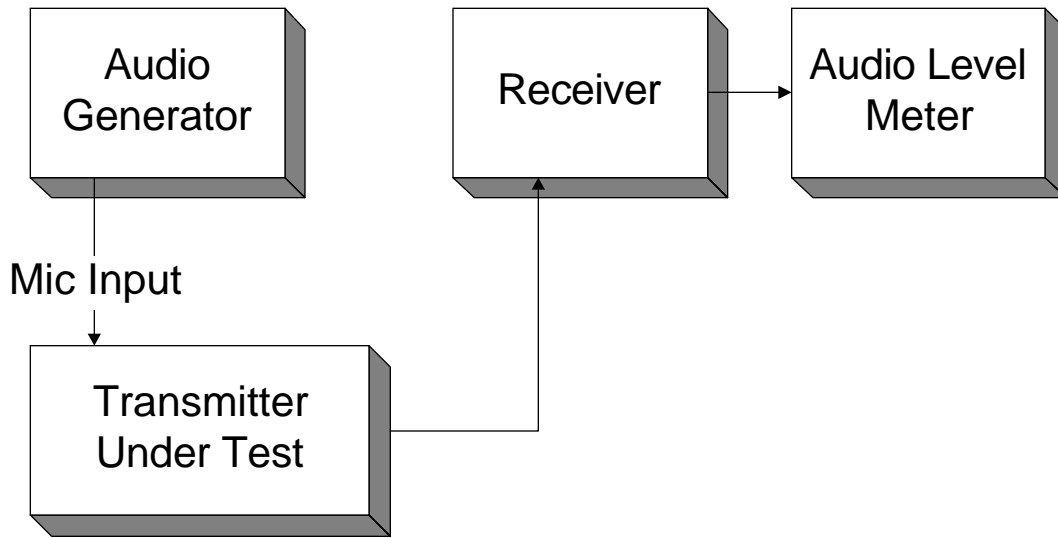

**Para. No. 2.1049 - Occupied Bandwidth**

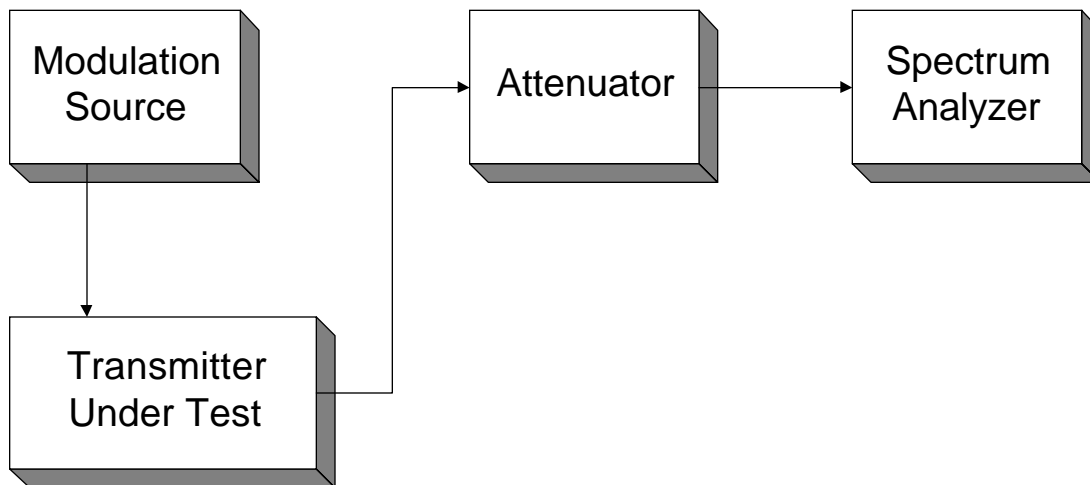



EQUIPMENT: Transmitter (VT-3A130)

---

**Para. No. 2.1051 - Spurious Emissions at Antenna Terminals**

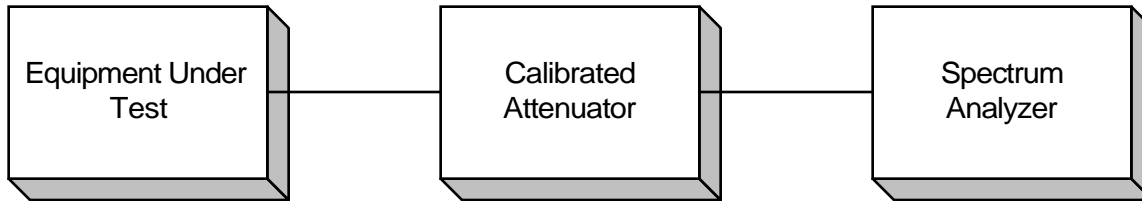

**Para. No. 2.1053 - Field Strength of Spurious Radiation**

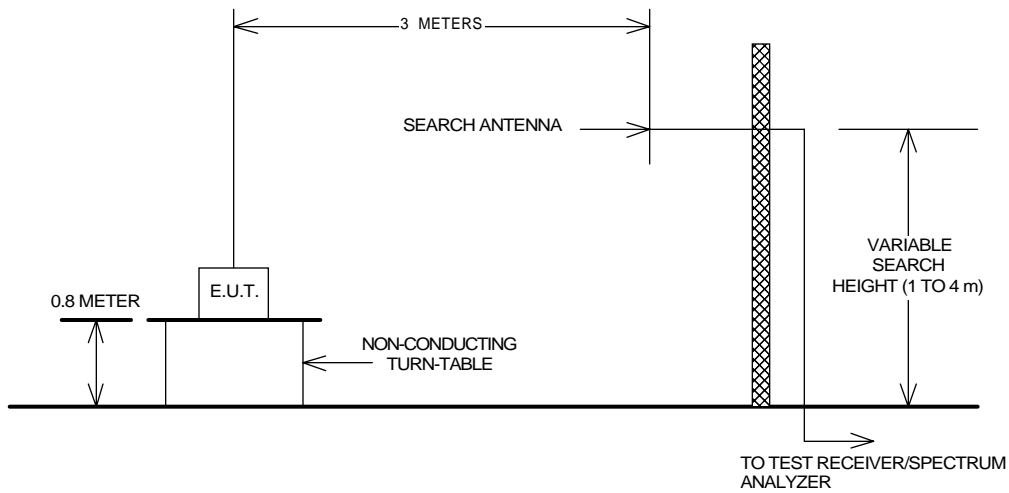

**Para. No. 2.1055 - Frequency Stability**

