



MT-4 RADIO SYSTEMS

PROJECT 25 DIGITAL UHF TRANSMITTER INSTRUCTION MANUAL UT-4R 406 - 470 MHz

Covers models:
UT-4R420, UT-4R460

Copyright © 2000 Daniels Electronics Ltd. All rights reserved. No part of this publication may be reproduced, stored in a retrieval system or transmitted in any form or by any means, electronic, mechanical, photocopying, recording or otherwise, without the prior written consent of Daniels Electronics Ltd.

DE™ is a registered trademark of Daniels Electronic Ltd. registered in the United States Patent and Trademark Office.

Issue:	1	Previous Issue:	N/A	
Issue Date:	July 2000	Previous Issue Date:	N/A	Daniels Electronics Ltd.
Printing Date:	July 2000			Victoria, BC.
Part No.:	IM23-UT4R400			PRINTED IN CANADA

Reviewed By:

Quality Assurance:

Claudia Boorman

Name

Signature

Date

NOTE:

The user's authority to operate this equipment could be revoked through any changes or modifications not expressly approved by Daniels Electronics Ltd.

The design of this equipment is subject to change due to continuous development. This equipment may incorporate minor changes in detail from the information contained in this manual.

TABLE OF CONTENTS

	Page
1	GENERAL..... 1-1
1.1	Introduction..... 1-1
1.2	Interim Operation..... 1-1
1.3	Manual Organization..... 1-1
1.4	UT-4R400 Transmitter Family Models..... 1-2
1.5	Performance Specifications 1-2
1.5.1	General..... 1-2
1.5.2	Audio Specifications..... 1-3
1.5.3	Physical Specifications 1-4
2	THEORY OF OPERATION..... 2-1
2.1	General..... 2-1
2.2	Power Supply 2-1
2.3	High Speed Serial Interconnect..... 2-2
2.4	Audio Circuits 2-2
2.5	PTT Circuitry..... 2-2
2.6	Microprocessor Board..... 2-2
2.7	Channel and Bank Selection 2-2
2.7.1	Channel Select Line Mapping..... 2-3
2.8	Jumper Functions and standard configuration..... 2-3
2.9	Hang Timer Selection..... 2-4
2.10	Kerchunk noise selection..... 2-5
2.11	Test Points 2-5
2.12	Connector Pinouts 2-6
2.12.1	Connector J9..... 2-6
2.12.2	Connector P1 2-6
2.13	Transmitter Programming..... 2-6
2.13.1	Transmitter Wide Options..... 2-7
2.13.1.1	Frequency Band 2-7
2.13.1.2	Source ID..... 2-7
2.13.1.3	Secure Hardware Equipped 2-7
2.13.1.4	Timeout Options 2-7
2.13.2	Channel Wide Settings 2-8
2.13.2.1	Channel Name 2-8
2.13.2.2	Frequency 2-8
2.13.2.3	Analog Bandwidth..... 2-8
2.13.2.4	Deviation..... 2-8
2.13.2.5	Channel Type 2-8
2.13.2.6	Audio Pre-emphasis..... 2-9
2.13.2.7	Timeout Value..... 2-9
2.13.2.8	Project 25 Squelch Settings: Network Access Code (NAC) 2-9
2.13.2.9	Project 25 Squelch Settings: Talk Group ID (TGID)..... 2-9

2.13.2.10	Analog Signaling Settings: Signaling	2-9
2.13.2.11	Analog Signaling Settings: CTCSS Tone.....	2-10
2.13.2.12	Analog Signaling Settings: Reverse Burst.....	2-10
2.13.2.13	Analog Signaling Settings: DCS Code.....	2-10
2.13.2.14	Analog Signaling Settings: Turnoff Code	2-10
2.13.2.15	Analog Squelch Settings: Invert DCS.....	2-10
3	Transmitter Assembly and Adjustment.....	3-1
3.1	Frequency Change.....	3-1
3.2	Minor Frequency Change.....	3-1
3.3	Major Frequency Change.....	3-2
3.4	Digital Signal Processor Board Alignment	3-2
3.4.1	Radio Service Software.....	3-2
3.4.2	Radio Programming Interface Module Interconnection	3-2
3.4.3	Reference Oscillator Adjustment.....	3-2
3.4.4	Transmitter Deviation Balance Adjustment	3-3
3.4.5	Transmitter Deviation Limit Adjustment	3-3
3.4.6	Audio Level Alignment	3-3
3.4.7	Amplifier Alignment.....	3-4
3.5	Recommended Test Equipment List.....	3-4
3.6	Repair Note.....	3-4
3.7	Printed Circuit board Numbering Convention	3-5
4	Repeater System Configuration.....	4-1
4.1	Interim Repeater	4-1
4.1.1	Repeater Interconnect Cable Pinout	4-2
4.2	Project 25 Compliant Repeater.....	4-2
4.3	Repeater System Troubleshooting.....	4-2
5	ILLUSTRATIONS.....	5-1
5.1	Digital Repeater Transmitter Front Panel	5-1
5.2	Digital Repeater Transmitter Exploded View.....	5-2
5.3	Digital Repeater Transmitter Block Diagram (Interim Mode).....	5-3
5.4	Digital Repeater Transmitter Schematic Diagram	5-4
5.5	Digital Repeater Transmitter Main Board Component Layout (Bottom).....	5-5
5.6	Digital Repeater Transmitter Main Board Component Layout (Top).....	5-6
5.7	Digital Repeater Microprocessor Board Component Layout (Bottom).....	5-7
5.8	Digital Repeater Microprocessor Board Component Layout (Top).....	5-8

6	PARTS LIST	6-1
6.1	Digital Repeater Transmitter Main Board Parts List.....	6-1
6.1.1	Digital Repeater Transmitter Main Board Electrical Parts List.....	6-1
6.1.2	Digital Repeater Transmitter Main Board Mechanical Parts List.....	6-4
6.2	Digital Repeater Microprocessor Board Parts List	6-5
6.2.1	Digital Repeater Microprocessor Board Electrical Parts List.....	6-5
6.2.2	Digital Transmitter Additional PCBs.....	6-6
7	REVISION HISTORY	7-1

MODULE MANUALS

UHF Amplifier Instruction Manual UT-3/UT-4 406 - 470 MHz..... IM23-UT34400AMP

1 GENERAL

1.1 Introduction

The UR-4R400 Project 25 Digital Transmitters are low current, synthesized FM Transmitters capable of analog or Project 25 digital operation in 12.5 kHz (narrow band) or 25 (wide band) channels. They operate over the bands from 406-430 and 450-470 MHz. Modular design allows each of the Transmitter's internal modules to be individually assembled and tested, which facilitates construction, tuning, and general Transmitter maintenance.

The UT-4R400 Transmitter combines state of the art performance in a compact modular enclosure for applications ranging from remote mountain top repeaters to congested urban radio environments. Each Transmitter module is characterized by dependable, low maintenance performance under the most severe environmental conditions.

The UT-4R400 Transmitter is compatible with all Daniel's subrack and base station enclosures. It supports a basic analog interface, and may be used in a mixed system with MT-2 and MT-3 series Receivers and Transmitters.

1.2 Interim Operation

Although the UT-4R400 family of transmitters can generate Project 25 voice transmissions, it cannot currently be used to create a fully compliant Project 25 repeater. All hardware necessary to enable a fully compliant Project 25 transmitter is present, however a firmware upgrade will be required to achieve this capability. In its Interim Operation mode, the transmitter can accept baseband audio and remodulate it as a FM analog or Project 25 digital signal. In a repeater made up of an interim Receiver and Transmitter, a voice signal will be repeated in either mode, but other Project 25 digital information such as Network Addressing Code, Talk Group ID, and low speed data will be lost.

1.3 Manual Organization

The organization of this document reflects the modular construction of the UR-4 family of products. Each product is fully described within its respective "sub-manual"; all of which are contained within this document. In general, each of these sub-manuals contain:

1. A functional description and specification summary.
2. A detailed technical description (Theory of Operation).
3. Assembly, setup and alignment procedures relevant to the particular module.

The following sub-manual is contained within this document cluster:

UHF Amplifier Instruction Manual: This manual provides information on alignment and operation of the 2 and 8 Watt RF amplifier modules.

The following manual is also required for alignment of the UT-4 family transmitter.

Radio Service Software Manual: This manual provides instructions on using the PC-based Radio Programming Software package to perform Transmitter alignment and frequency and mode selection. This manual is available as a PDF file on CD that is supplied in the Radio Service Software and Interface Kit.

1.4 UT-4R400 Transmitter Family Models

There are four distinct models in the UT-4R400 Transmitter family each with different bands of operation and power outputs. The four models are as follows:

- UT-4R420-2 - 406-430 MHz band, 0.5-2.0 Watt
- UT-4R420-8 - 406-430 MHz band, 2.0-8.0 Watt
- UT-4R460-2 - 450-470 MHz band, 0.5-2.0 Watt
- UT-4R460-8 - 450-470 MHz band, 2.0-8.0 Watt

The transmitters' band of operation is determined by select components in the amplifier.

1.5 Performance Specifications

1.5.1 General

The following is a general set of specifications for the generic UT-4R400 transmitter. Additional specifications, specific to individual modules may be found in their respective sub manuals.

Type:	MT-4 Series Transmitter.
Family:	UT-4 406 - 470 MHz.
Compatibility:	MT-2 and MT-3 Series Radio Systems, Project 25 interoperable.
Frequency Range:	406 to 430 MHz., 450 to 470 MHz
RF Power Output:	0.5 to 2.0 or 2.0 to 8.0 W Continuous.
Modulation:	Analog: 11K0F3E or 16K0F3E (Frequency Modulation). Project 25: 8K10F1E
System Impedance:	50 Ω ; Type N connector.
Duty Cycle:	100%; Continuous operation from -30°C to +60°C.
Emissions:	-66 dBw
Transmitter Mismatch Protection:	20:1 VSWR at all phase angles.
Operating Temperature Range:	-30°C to +60°C, optional -40°C temperature test.
Operating Humidity:	95% RH (non-condensing) at +25°C.
Operating Voltage:	+13.8 Vdc Nominal (range +11 to +16 Vdc), +9.5 Vdc Regulated.
Transmit Current:	1.7 Amps at 2 Watts RF Power Output, 2.8 Amps at 8 Watts RF Power Output

Front Panel Controls:	NORM (repeat mode), OFF, and KEY TX (Tx on). MIC MODE: ANALOG and DIGITAL.
PTT Activation:	<ul style="list-style-type: none"> • Active to ground; Microphone activated; • Front Panel switch: KEY TX
PTT Time-Out-Timer:	Programmable from 1 sec. to 8 hrs. (default 5 min.), using Radio Programming Software package.
Channel Spacing:	12.5 kHz or 25 kHz.
Frequency Stability:	Standard: ± 2.5 ppm, -30°C to $+60^{\circ}\text{C}$. Optional: -40°C to $+60^{\circ}\text{C}$.
Channel Selection:	In 5.0 or 6.25 kHz increments selected with Radio Programming Software package.
Standby Current :	100 mA;
DOC Type Approval:	TBA
FCC Type Acceptance:	TBA

1.5.2 Audio Specifications

Audio Input:	Unbalanced, 600 or 4750 ohm selectable input impedance.
Audio Response:	Pre-emphasis (6 dB per octave); +0.5 to -2.0 dB from 300 Hz to 3 kHz
Audio Deviation Limiting:	+/- 2.5 kHz, +/- 5.0 kHz
Audio Distortion:	Less than 3% THD; 1 kHz tone at 1.5 kHz or 3 kHz deviation
Hum and Noise:	-45 dB typical

1.5.3 Physical Specifications

Physical Dimensions:	Width: 7.1 cm (2.8 in)	Height: 12.8 cm (5.05 in)	Depth: 19 cm (7.5 in)
Module Weight:	1.4 kg (3.0 lbs.)		
Corrosion Prevention:	Anodized aluminum construction. Stainless steel hardware. Selectively conformal coated glass epoxy 2 and 4 layer printed circuit boards. Gold plated module connectors.		
Module Design:	Compact Eurostandard modular design. Plug-in modules mate with Daniels standard M3 repeater subrack. Subracks / modules comply with IEEE 1101, DIN 41494 and IEC 297-3 (mechanical size / modular arrangement).		
External Connections:	RF Connection: type N connector located on the transmitter module front panel. Motherboard Connections (Audio, Power, and Control) are made through a 48 pin, gold plated, type F connector on the rear of the transmitter module. User connection made through mated "mother board" assembly of the repeater subrack. Type F standard connector complies with DIN 41612 Level 2 (200 mating cycles, 4 day 10 ppm SO ₂ gas test with no functional impairment and no change in contact resistance). Digital I/O: 8-pin RJ-45		
Handle Text Colour:	Black		

2 THEORY OF OPERATION

2.1 General

An UT-4R400 Transmitter is constructed using two primary modules: the MT-4 Digital Transmitter Main Board and the UT-4 Amplifier Board. The Main Board supports two plug in modules: the Digital Signal Processor Board and the Transceiver RF Board. The Digital Signal Processor Board also supports another module, the Microprocessor Board.

The MT-4 Transmitter Main Board accepts a baseband audio signal, performs some level adjustment, and applies it to the Digital Signal Processor Board. The microprocessor on the Digital Signal Processor Board samples the audio signal and converts the digitized audio to a modulation signal. When the transmitter is required to produce an analog FM modulated carrier, pre-emphasis and limiting functions are applied using DSP techniques, and the resulting modulation signal is converted back to baseband and applied to the VCO on the Transceiver RF Board, thus producing an analog modulated carrier. When P25 Digital transmit mode is required, the sampled audio is passed through a vocoder process in the DSP, which compresses the voice signal, and adds error correction information to produce a 9600 bps data stream. The data stream is applied to a quadrature modulator in the DSP and the resulting modulation data is converted to an analog waveform which is applied to the VCO on the Transceiver RF Board, thus producing a digitally modulated carrier.

The Microprocessor board provides an interface between the Digital Signal Processor Board and the user controls such as PTT inputs, front panel switches, and hang timer selection jumpers. It is responsible for generating the optional “kerchunk” noise which can be added to the audio at the end of a transmission to simulate the burst of noise heard when a traditional analog receiver squelches. This can be a useful aid to repeater users, who are used to listening for the noise as an indicator that they’ve successfully keyed up the repeater.

The UT-4 Amplifier provides the final stage of RF amplification and filtering for the MT-4 Transmitter. The amplifier has inputs for the RF signal from the Transceiver RF Board, and for DC power. It has outputs for the amplified RF signal and for forward and reverse power alarms. Two power options are available, with each power option being available in two frequency bands.

Hardware support for fully compliant P25 operation is provided in the form of a high speed serial I/O connection at the front panel RJ-45 connector. Future firmware upgrades will allow the transmitter to accept data and voice signals in digital form from a MT-4 P25 Compliant Receiver for fully digital repeat capability.

2.2 Power Supply

Regulated +9.5VDC enters the transmitter module from the M-3 subrack at P1-B6 & Z6. It is distributed through diodes D3 and D4 to the Transceiver RF Board, and to voltage regulators U1 and U2. U1 produces a clean +8Vdc supply for the analog audio circuitry. U2 produces a regulated +5Vdc supply to drive the high speed serial LVDS serial driver and the microprocessor board.

2.3 High Speed Serial Interconnect

Fully compliant Project 25 operation will be supported by the transmitter via a firmware upgrade. At that time, IC U4 will be enabled. It provides a high speed bi-direction LVDS (Low Voltage Differential Signaling) port on front panel jack J1. Each signal path uses a balanced current loop to achieve high serial bit rates with low noise. These signaling paths will provide a means for digital and analog RF signals to be passed from receiver to transmitter for repeating.

2.4 Audio Circuits

Op amp U3a serves a mixer for audio signals from the microphone connector MIC1, unbalanced audio1 input, and the “kerchunk” audio signal generated by the Microprocessor Board. Level adjustment is provided by potentiometer R11. Separate control of the microphone input level and DC biasing is provided by potentiometer R9.

2.5 PTT Circuitry

The transmitter may be keyed by either grounding the PTT* input at P1-B10 & Z10, by moving the front panel power switch to the “KEY TX” position, or by pulling the ANALOG_COR* or DIGITAL_COR* inputs low. These inputs are monitored by microprocessor U6 and used in conjunction with the position of the front panel “MIC MODE” switch to generate a sequence of signals to the Digital Signal Processor Board which will cause it to key up in either P25 Digital or Analog mode.

2.6 Microprocessor Board

The microprocessor board contains U6, a 68HC11E2 microcontroller. U6 is responsible for monitoring all sources of Push-To-Talk information, the Bank Select Input, and the Mic Mode front panel switch. It generates bank select and PTT signals to the Digital Signal Processor Board, the “kerchunk” audio signal, and drives the front panel LEDs to indicate that the transmitter is active in either P25 Digital or Analog mode. U6 also monitors the state of the Hang Time select jumpers to determine whether the transmitter should remain keyed after a source of PTT disappears, and whether a “kerchunk” noise should be inserted at the end of the transmission.

2.7 Channel and Bank Selection

Four channel select lines CSEL0-3 are named on the M-3 motherboard, and are brought into the receiver module by pins on connector P1, allowing selection of 16 different channels. These signals normally float high (+5V) in the receiver, but are typically pulled low by jumpers on the M-3 motherboard to select channel 1 by default. In addition, a bank select input is provided to switch between Bank A and B, each of which has 16 channels. In the Interim mode of operation, the bank select input has no effect. A convention has been adopted to use Bank A channels as analog channels, and Bank B channels as P25 Digital channels. Using this convention, it is possible to have an MT-4 Interim Receiver connected to the transmitter to form a repeater that repeats an incoming voice signal in the same mode in which it is received. The LEDs on the transmitter front panel will correctly indicate Analog or Digital operation as long as this convention is followed. In addition, the Mic Mode switch on the front panel will operate correctly, selecting Bank A for analog channels, and Bank B for digital channels, as long as this convention is followed.

2.7.1 Channel Select Line Mapping

The table below shows the relationship between the states of the channel select lines. Note that the channel select lines follow a binary pattern, but that the binary “0” represents channel 1.

CSEL3	CSEL2	CSEL1	CSEL0	Channel selected
LO	LO	LO	LO	1
LO	LO	LO	HI	2
LO	LO	HI	LO	3
LO	LO	HI	HI	4
LO	HI	LO	LO	5
LO	HI	LO	HI	6
LO	HI	HI	LO	7
LO	HI	HI	HI	8
HI	LO	LO	LO	9
HI	LO	LO	HI	10
HI	LO	HI	LO	11
HI	LO	HI	HI	12
HI	HI	LO	LO	13
HI	HI	LO	HI	14
HI	HI	HI	LO	15
HI	HI	HI	HI	16

2.8 Jumper Functions and standard configuration

Jumper	Default Position	Function when installed
JU1	Out	Forces HC11 microprocessor to reset mode
JU2	In	Enables PTT input from subrack
JU3	In	Enables Unbalanced audio input from subrack
JU4	In	Enables 600 ohm input impedance (impedance about 15k when out)
JU5	Out	Allows Digital Signal Processor board to turn on LVDS receiver
JU6	Out	Forces LVDS receiver on
JU7	Out	Connects LVDS receiver output to Digital Signal Processor board input
JU8	Out	Connects Digital Signal Processor board output to LVDS transmitter
JU9	Out	Allows Digital Signal Processor board to turn on LVDS transmitter
JU10	Out	Enables LVDS bus resistive termination
JU11	In	Disables LVDS transmitter
JU12	In	Connects LH_DATA signal to J1 for programming
JU13	In	Connects baseband audio from J9 to audio circuitry
JU14	In	Connects ANALOG_COR* input from J9
JU15	In	Connects LVDS bus to J9
JU16	In	Connects LVDS bus to J9
JU17	In	Connects DIGITAL_COR* input from J9
JU18	In	Connects +8.8VDC to J1 to power RPIM
JU19	In	Connects BUSY signal to J1 for programming
JU20	Out	Connects future data port to M-3 motherboard
JU21	Out	Connects future data port to M-3 motherboard
JU22	Out	Connects future data port to M-3 motherboard
JU23	Out	Connects future data port to M-3 motherboard

JU24	Out	Connects fr pnl MIC MODE switch directly to Digital Signal Processor board
JU25	Out	Connects summed PTT signals directly to Digital Signal Processor board
JU26	In	Connects channel select line CSEL3 to Digital Signal Processor board
JU27	Out	Connects Digital Signal Processor board to green front panel LED
JU28	Out	Grounds Digital Signal Processor board bank select input
JU29	Out	Connects Bank Select input to directly to the Digital Signal Processor board
JU30	In	Connects channel select line CSEL0 to Digital Signal Processor board
JU31	In	Connects channel select line CSEL1 to Digital Signal Processor board
JU32	In	Connects channel select line CSEL2 to Digital Signal Processor board
JU33	A	Connects 68HC11 uP to yellow front panel LED
JU34	In	Enables yellow front panel LED
JU35	In	Enables green front panel LED
JU36	In	Enables yellow front panel LED
JU37	In	Connects TX PTT OUT* signal to subrack
JU38	Out	Allows bootstrap programming of 68HC11 uP
JU39	Out	Allows programming of EPROM version of 68HC11 uP
JU40	Out	Provides serial communications for bootstrap programming
JU41	In	Allows 68HC11 uP to control green front panel LED
JU42	In	Allows 68HC11 uP to control yellow front panel LED
JU43	In	Bit 3 (MSB) of hang time select
JU44	In	Bit 2 of hang time select
JU45	In	Bit 1 of hang time select
JU46	In	Bit 0 (LSB) of hang time select
JU47	Out	Disables “kerchunk” noise at the end of a transmission
JU48	Out	No function
JU49	Out	No function
JU50	Out	No function

2.9 Hang Timer Selection

Hang time is a selectable time delay, which can be enabled to keep the transmitter keyed after its PTT input is released. It can be used to keep a RF channel open in low signal conditions when the receiver might be squelching intermittently. It is also commonly used by repeater users in order to keep the transmitter keyed long enough to key their mobile radios briefly at the end of their transmission in order to be sure that they’ve hit the repeater. The duration of the hang timer is selectable in 250 ms. increments from 0 (disabled) to 3.75 sec by changing the states of jumpers JU43-46. A table of the hang timer durations is shown below. Note that the Hang Time is applied only when the radio is keyed by the ANALOG_COR* or DIGITAL_COR* inputs, not from the front panel Mic connector or the PTT signal from the M-3 subrack.

JU46	JU45	JU44	JU43	Hang Time
IN	IN	IN	IN	0 (disabled)
IN	IN	IN	OUT	250 ms
IN	IN	OUT	IN	500 ms
IN	IN	OUT	OUT	750 ms
IN	OUT	IN	IN	1 sec
IN	OUT	IN	OUT	1.25 sec
IN	OUT	OUT	IN	1.5 sec
IN	OUT	OUT	OUT	1.75 sec
OUT	IN	IN	IN	2 sec

OUT	IN	IN	OUT	2.25 sec
OUT	IN	OUT	IN	2.5 sec
OUT	IN	OUT	OUT	2.75 sec
OUT	OUT	IN	IN	3 sec
OUT	OUT	IN	OUT	3.25 sec
OUT	OUT	OUT	IN	3.5 sec
OUT	OUT	OUT	OUT	3.75 sec

2.10 Kerchunk noise selection

In addition to the selectable hang timer, it is possible to add a burst of noise to the end of each transmission, after the hang time has expired. When the transmitter is used in a repeater configuration in digital repeat mode, it may be difficult for a mobile radio user to hear that he has successfully “hit” the repeater, since P25 radios usually operate in a “silent squelch” mode. The kerchunk noise is an audible indicator that the repeater was indeed keyed. Remove JU47 to enable the kerchunk noise.

Note that the kerchunk noise is applied only when the radio is keyed by the ANALOG_COR* or DIGITAL_COR* inputs, not from the front panel Mic connector or the PTT signal from the M-3 subrack. In addition, if the radio is keyed again before the hang time has expired, the kerchunk noise will not be sent until the hang timer is set again by removal of the keying source.

2.11 Test Points

Test Point	Signal Monitored	Typical voltage
TP1	+8.0VDC regulated	+8.0 VDC
TP2	Summed PTT inputs	+5 VDC inactive, <0.2VDC active
TP3	Summing junction for audio signals	+4 VDC, 0 VAC
TP4	Output of audio summing amplifier	+4 VDC, 100 mVAC
TP5	mid-supply bias voltage for audio circuits	+4 VDC
TP6	Digital Signal Processor board output to enable RF amplifier	0 VDC inactive, +4.5 VDC active

2.12 Connector Pinouts

2.12.1 Connector J9

A dual, 8 position RJ-45 jack is mounted on the Connector Board so as to be accessible from the receiver's front panel. The pins of each of the two jacks are wired identically. The following are the connections on J1.

Pin	Signal
1	LH_DATA
2	AUDIO
3	ANALOG_COR*
4	LVDS DATA+
5	LVDS DATA-
6	DIGITAL_COR*
7	+8.8VDC TO RPIM
8	SB9600_BUSY

2.12.2 Connector P1

The Connector Board employs a 48 pin Eurostandard connector for interfacing to most receiver power, audio, and control functions. The following are the Main Board backplane connections to the M-3 Motherboard.

Pin	Name	Pin	Name	Pin	Name
D2	No Connect	B2	+13.8 Vdc	Z2	+13.8 Vdc
D4	No Connect	B4	No Connect	Z4	No Connect
D6	No Connect	B6	+9.5 Vdc	Z6	+9.5 Vdc
D8	No Connect	B8	No Connect	Z8	No Connect
D10	No Connect	B10	PTT* Input	Z10	PTT* Input
D12	No Connect	B12	Bank A/B* Input	Z12	Bank A/B* Input
D14	No Connect	B14	No Connect	Z14	No Connect
D16	No Connect	B16	No Connect	Z16	No Connect
D18	No Connect	B18	Unbal. Audio 2 Input	Z18	Unbal Audio 1 input
D20	Channel Select 0 (LSB)	B20	No Connect	Z20	No Connect
D22	Channel Select 1	B22	RS-232 Out	Z22	RTS In
D24	Channel Select 2	B24	PTT* Output	Z24	CTS Out
D26	Channel Select 3 (MSB)	B26	VSWR Fwd Output	Z26	VSWR Rev Output
D28	No Connect	B28	RS-232 Input	Z28	Reserved
D30	No Connect	B30	Ground	Z30	Ground
D32	No Connect	B32	Ground	Z32	Ground

2.13 Transmitter Programming

Transmitter programming is performed with the PC-based Radio Service Software (RSS). A Daniels Radio Programming Interface Module (RPIM) is used with a special programming cable to connect the serial port of an IBM compatible computer to the Digital I/O port on the front panel of the Transmitter module. The RSS runs under Microsoft Windows 3.1 and Windows 95/98, and allows the Transmitter to be programmed for operating frequencies, CTCSS and DCS signaling, and modulation type. Analog test modes may be selected by the Radio Programming Software, as well as test modes specific to Project 25 digital operation, such as Bit Error Rate testing.

Transmitter settings are divided into two categories, Radio Wide options, which apply at all times, and Channel Wide options, which can be programmed differently for each channel. When the Transmitter menu is selected from the main screen, both the Radio Wide and Channel Wide options for the current channel are displayed.

The RSS may be used to save a Transmitter configuration to disk. This function allows a radio shop to save a “standard” configuration, and use it as a starting configuration for all Transmitters. An archive of configurations from each radio system in operation may also be kept so that replacement radios can be programmed easily.

2.13.1 Transmitter Wide Options

Several options may be set which affect the operation of the Transmitter on a global basis.

2.13.1.1 Frequency Band

There are four Frequency Bands available for Transmitters:

VHF (low band) 136 - 150 MHz,

VHF (high band) 150 - 174 MHz,

UHF (low band) 406 - 430 MHz,

UHF (high band) 450 - 470 MHz.

When the Frequency Band is changed, the **Frequency** field in every Transmitter channel will be changed to the lowest frequency in the band.

Warning: Daniels Transmitters are built differently depending upon the band. Therefore, you cannot change a transmitter to a different band without a hardware change.

2.13.1.2 Source ID

This field contains the unique Transmitter Source ID in Hexadecimal. (There is no need to enter an initial ‘\$’ character.) The default value is \$1. The spin button to the right of this field allows you to incrementally change the Source ID.

The Source ID will be transmitted along with every P25 voice frame and each Transmitter should have a different number.

2.13.1.3 Secure Hardware Equipped

This setting is currently not used for Repeater Transmitters, but is supported for programming of Daniels P25 Base Transmitters. Correct repeater operation does not require that an encrypted signal be decrypted. An external Repeater Controller may include encryption and decryption hardware for those cases, which require it.

2.13.1.4 Timeout Options

The transmitter provides a selectable timeout timer for each channel, which causes the transmitter to be de-keyed after the selected interval of continuous transmission, has been completed. Four transmitter timeout values are provided, and one of the timeout values may be used in each of the 32 programmable channels. The range of values is from 15 to 465 seconds in increments of 15 seconds, or Infinite Time may be chosen

These selected Timeouts can then be used in the Timeout Value field in each Transmitter Channel Setting. These fields are used to program the parameters for a single Transmitter channel only. There are 32 different available channels labeled A1 - A16 and B1 - B16. The parameters for each channel are independent of parameters in other channels.

2.13.2 Channel Wide Settings

The Receiver may be programmed with up to 32 channels, each with a different frequency, channel spacing and modulation type. The channels are arranged in two banks of 16 channels each, referred to as Bank A and Bank B. In this manual, a specific channel is referred to by its bank and channel i.e. B12 would refer to channel 12 in bank B. The following are all the settings, which may be programmed on a per-channel basis:

2.13.2.1 Channel Name

Each channel may be assigned a text name of up to 11 characters. The name is stored in the radio, but is never broadcast. It is provided as a means of identifying the channel during configuration. The channel name will default to the bank and channel number (i.e. "A1" for bank A, channel 1).

2.13.2.2 Frequency

The transmitter's frequency may be set here. The Radio Programming Software will only allow frequencies within the operation band (set in the Transmitter Wide options above) to be entered.

2.13.2.3 Analog Bandwidth

This setting should be changed to match the channel spacing and bandwidth of the analog channel. This setting is visible only when the Channel Type field is set to Analog.

2.13.2.4 Deviation

This is a read-only field that shows the maximum amount that the transmitter frequency will deviate. This field changes automatically in response to the Channel Bandwidth setting. A bandwidth of 25 kHz selects a maximum deviation of 5 kHz, while a bandwidth of 12.5 kHz selects a maximum deviation of 2.5 kHz.

2.13.2.5 Channel Type

Allowed values here are Project 25 and Analog. Project 25 signaling is a purely digital mode compatible with other APCO Project 25 radios. Analog mode is for transmitting analog FM modulated signals. In either case, the audio at the Unbalanced Audio input is used to modulate the transmitter. The audio signal may also be injected at the CNTL BUS jack on the front panel for interfacing to MT-4 Interim Receivers.

2.13.2.6 Audio Pre-emphasis

For analog channels, the standard 6 dB/octave pre-emphasis curve may be either disabled or applied to the transmitted audio. Pre-emphasis is applied to audio from the Unbalanced Audio Input, the microphone input, and the audio input on the CNTL BUS jack on the front panel.

2.13.2.7 Timeout Value

This option allows selection of one of four preset timeout timer values. Each of the four preset values is set in the Transmitter Wide Settings panel, in the section called Timeout Options. If the transmitter is keyed continuously for longer than the selected time, it will be de-keyed. To reset the timeout timer, the applied PTT* signal or ANALOG_COR* or DIGITAL_COR* signal must be removed for a period at least as long as the hang time.

2.13.2.8 Project 25 Squelch Settings: Network Access Code (NAC)

For P25 channels, the transmitted Network Access Code can be set here. The Network Access Code (NAC) is a 12 bit field embedded within every P25 voice call. NACs are primarily used for two purposes:

- 1) They allow a large system coverage area to be serviced by separate repeaters.
- 2) They allow multiple repeaters to service multiple systems with overlapping coverage areas. NACs achieve these functions by minimizing co-channel interference. This is done by keeping the receiver squelched unless a signal with a matching NAC arrives.

The NAC's 12 bit field ranges from 0 to 4095 (hexadecimal \$0 to \$FFF). The default value is \$293 and two values are defined for special functions.

- 1) When a receiver is set for NAC \$F7E, it unsquelches on any incoming NAC.
- 2) If a repeater receiver is set for NAC \$F7F, it also unsquelches on any incoming NAC. When the P25 Compliant repeater is released, \$F7F allows the repeater to repeat any incoming NAC.

2.13.2.9 Project 25 Squelch Settings: Talk Group ID (TGID)

The transmitter's Talk Group ID can be set here. This applies to Project 25 signals only

The Talk Group Identifier (TGID) is a 16 bit field embedded within every P25 voice call. The purpose of a Talkgroup is to allow logical groupings of radio users into distinct organizations. The TGID's 16 bit field ranges from 0 to 65,535 (hexadecimal \$0 to \$FFFF). Three of these values are set up for special functions.

- 1) The default value of \$1 should be used in systems where no other talkgroups are defined.
- 2) A value of \$0 corresponds to "no-one" or a talk group with no users.
- 3) A value of \$FFFF is reserved as a talk group which includes everyone.

2.13.2.10 Analog Signaling Settings: Signaling

This setting may be set to No Tone, CTCSS or DCS. When either CTCSS or DCS Squelch Type is selected, additional combo boxes appear to allow selection of a particular tone or code.

2.13.2.11 Analog Signaling Settings: CTCSS Tone

This field allows selection of any of 42 EIA CTCSS tones.

2.13.2.12 Analog Signaling Settings: Reverse Burst

For CTCSS channels only: When this field is set to “Enabled”, each transmission is terminated with a short burst of CTCSS tone with its phase reversed 180 degrees. This allows suitably equipped receivers to squelch their audio circuits before the transmitted carrier is dropped, giving a silent squelch operation.

2.13.2.13 Analog Signaling Settings: DCS Code

This field allows selection of any of 83 DCS tones.

2.13.2.14 Analog Signaling Settings: Turnoff Code

For DCS channels only: When this field is set to “Enabled”, each transmission is terminated with a short burst of 138 Hz tone. This allows suitably equipped receivers to squelch their audio circuits before the transmitted carrier is dropped, giving a silent squelch operation.

2.13.2.15 Analog Squelch Settings: Invert DCS

This setting is in effect when the Squelch Type is set to DCS. It may be set to Normal DCS or Invert DCS. When Invert DCS is selected, the transmitter will broadcast a DCS signal whose polarity is reversed. This should not be required unless the distant receiver has its DCS configured with the wrong polarity, typically when DCS has been installed as an after-market option.

3 Transmitter Assembly and Adjustment

The Transceiver RF and Digital Signal Processor module are mounted on the Transmitter Main Board, and the Microprocessor board plugs into the Digital Signal Processor Board. Two ribbon cables allow the Microprocessor board to make connection with the Main board. A metal shield is soldered in place over the Transceiver RF module, and another shield is held in place over the Digital Signal Processor and Microprocessor boards by screws. The RF Amplifier module is secured on the Main Board by screws, and an enclosure is formed by an extruded aluminum shell that slides over the Transmitter Main Board as illustrated in section 5.2). This shell also serves as a heat sink to remove heat from the Amplifier module and for this reason, it is important that the four screws that bond the shell to the amplifier module (Screws B in Section (5.2) be installed before prolonged operation of the transmitter. Moreover, the surface of the Amplifier module that contacts the shell should be clean and free of foreign material. The enclosure is completed by the installation of front and rear plates, which are fastened to the Transmitter Main Board (see Transmitter Main Board Manual for parts lists).

Transmitter alignment is performed on a module by module basis and detailed steps are provided in the respective manuals. Alignment is simplified by using a SR-3 Sub rack, SM-3 System Monitor, and RF extender cable to provide transmitter power and signal interconnection. Alternatively, +9.5 Vdc and +13.8 Vdc as well as any required test signal may be applied directly to the individual modules. Refer to the corresponding manuals for details.

3.1 Frequency Change

The transmitter is initially aligned at the factory for the frequency stamped on the 'Factory Set Operating Frequency' label (see section 3.1). This label should list the frequency at which the last complete transmitter alignment was performed. For a small frequency change, a simple channel change (see section 2.2) may be all that is required. A larger frequency change may involve the realignment of other modules. The frequency change in question is the *accumulated frequency change* in relation to the frequency stamped on the label. For example, if the frequency is changed by 0.5 MHz from that stamped on the label, then a second frequency change of 1 MHz in the same direction would result in a total change of 1.5 MHz. The action taken would be based on the 1.5 MHz value. Failure to perform realignment after a large frequency change could result in unreliable transmitter operation or transmitter operation that does not conform to the published specifications. The allowable frequency change is summarized below.

Note: It is advisable to confirm these frequency ranges with the individual module manuals notably the Amplifier and Synthesizer Module, as they are subject to change with updated versions. The values in the module manuals take precedent over those tabulated (following page).

<u>Size of Frequency Change</u>	<u>Modules to be Aligned</u>
Less than ± 1 MHz	No alignment required, check output power
Greater than ± 1 MHz	Transmitter Power Amplifier

3.2 Minor Frequency Change

Changes less than ± 1 MHz from a previously tuned working receive frequency will generally not require any adjustment. Change the frequency using the Radio Programming Software package. Verify that the Transmitter Output power is at the desired level.

3.3 Major Frequency Change

Changes greater than ± 1 MHz from a previously tuned transmit frequency will require RF Amplifier alignment as per the UHF Amplifier Instruction Manual. The Digital Transmitter Signal Processor Board, once programmed for the new frequency, should not require any alignment, as it is capable of operation over the entire band from 406-470 MHz.

3.4 Digital Signal Processor Board Alignment

If the Digital Signal Processor or Transceiver RF Boards have been replaced, it is necessary to align the Digital Signal Processor Board. This consists of adjusting the reference oscillator frequency, aligning the deviation balance at high and low modulation frequencies, and adjusting the deviation limiting at a number of frequencies over the operational band of the Receiver.

3.4.1 Radio Service Software

The Radio Service Software is an application that runs under Microsoft Windows 3.1, 95, or 98, and is used to program the radio's channel frequencies and other operational characteristics. It is used in conjunction with the Radio Programming Interface Module to read and write information to the internal memory of the radio. For information about installing and using the Radio Service Software, see the Radio Service Software Manual, which is available as an Adobe Acrobat file (.PDF) on the CD-ROM, which contains the Radio Service Software.

3.4.2 Radio Programming Interface Module Interconnection

The Radio Programming Interface Module is used to make a connection between the computer running the Radio Service Software and the radio module. On the computer side, it connects to an RS-232 serial port via a standard nine pin serial cable. Another cable connects the Radio Programming Interface Module to the radio to be programmed. Once the connections are made, the Radio Service Software may be run on the computer and the radio switched on. The Radio Service Software must be configured to use the correct serial port on the computer. This is done in the Preferences menu of the Main screen. When the radio is switched on, the Power LED on the Radio Programming Interface Module should light. To test the serial connection, open the Receiver Configuration screen by clicking on the Transmitter button in the Main screen. Click on the Receiver menu, then on the ID... menu item. Click on the Read ID button. The Data LED on the Radio Programming Interface Module should light briefly and the serial number, model number, and last programmed date should appear in the appropriate fields.

3.4.3 Reference Oscillator Adjustment

The reference oscillator provides an accurate frequency standard to which the transmitter's carrier signal is phase locked. To adjust the reference oscillator frequency, disconnect the Transceiver RF Board from the amplifier module by separating the SMB connectors. For this test, the Transceiver RF board will generate a 0 dBm RF signal from its RF output. Connect the RF output cable of the Transceiver RF board to a frequency counter or communications test set. Connect the transmitter to an IBM compatible computer using the Programming Cable. Apply power to the transmitter and run the Radio Programming Software. Navigate to the TRANSMITTER \ SERVICE \ REFERENCE OSCILLATOR menu, where you will see a test frequency displayed and a slider to adjust the frequency. Click on the "ENABLE TX" button and move the slider until the frequency

measured by the frequency counter matches the test frequency displayed on the screen to within +/- 150 Hz. Click on the "UPDATE SOFTPOT" button to save the setting in the transmitter's non-volatile memory. This completes the adjustment of the reference oscillator. Leave the Transceiver RF Board disconnected from the amplifier module and continue with the next alignment procedure.

3.4.4 Transmitter Deviation Balance Adjustment

This adjustment equalizes the modulation sensitivity of the low and high frequency modulation paths on the Transceiver RF board. To perform the adjustment, disconnect the Transceiver RF Board from the amplifier module by separating the SMB connectors. Connect the RF output cable of the Transceiver RF board to a communications test set. Connect the transmitter to an IBM compatible computer using the Programming Cable. Apply power to the transmitter and run the Radio Programming Software. Navigate to the TRANSMITTER \ SERVICE TRANSMITTER \ DEVIATION BALANCE screen, where you will see a list of test frequencies and current SoftPot values for each frequency. Select the radio button next to the first test frequency and click on the "LOW PTT" button. This causes an internally generated 80 Hz tone to be applied to the modulator. Note the deviation of the carrier on the communications test set, and click on the "HIGH PTT" button. This causes a 3 kHz tone to be applied to the modulator. Adjust the slider next to the test frequency until the measured deviation matches that of the 80 Hz tone. Now click on the "LOW PTT" button again to check the deviation. If the deviation has changed from the original reading, note the new deviation and perform the adjustment at the high frequency again. It may require several iterations of this process to get the deviations to match within +/- 2%. When the deviations match, click on the "UPDATE SOFTPOT" button to save the setting in the transmitter's non-volatile memory. Repeat the adjustment process for each of the test frequencies. Leave the Transceiver RF Board disconnected from the amplifier module and continue with the next alignment procedure.

3.4.5 Transmitter Deviation Limit Adjustment

This adjustment prevents over deviation of the transmitter's carrier. To perform the adjustment, disconnect the Transceiver RF Board from the amplifier module by separating the SMB connectors. Connect the RF output cable of the Transceiver RF board to a communications test set. Connect the transmitter to an IBM compatible computer using the Programming Cable. Apply power to the transmitter and run the Radio Programming Software. Navigate to the TRANSMITTER \ SERVICE TRANSMITTER \ ADJUST DEVIATION LIMITS menu item, where you will see a list of test frequencies and current SoftPot values for each frequency. Select the radio button next to the first test frequency and click on the "ENABLE TX" button to key the transmitter. Adjust the slider next to the selected test frequency under the measured deviation of the carrier is between 2785 Hz and 2885 Hz. Click on the "UPDATE SOFTPOT" button to save the new setting to the radio's non-volatile memory. Repeat the process for each test frequency. This completes the adjustment process for the transmitter deviation limits, and completes the alignment process for the Digital Signal Processor Board.

3.4.6 Audio Level Alignment

The audio level should be set after all other alignments have been completed. The transmitter should be programmed to an analog channel for the purposes of the test, since the vocoder in the transmitter encodes pure sine signals with a large amount of distortion. The transmitter's Unbalanced Audio input (at P1-Z18) should be connected to an audio signal generator set up to deliver a 1 kHz tone at a level of 308 mVRMS (-8 dBm in a 600 ohm system). The RF output of the transmitter should be connected to a service monitor set to monitor the deviation of the carrier

signal generated by the transmitter. Key the transmitter by moving the front panel power switch to the “KEY” position and adjust pot R11 to achieve a deviation of 3 kHz (for a 25 kHz wide channel) or 1.5 kHz (for a 12.5 kHz wide channel).

Next, de-key the transmitter and remove the audio signal generator. Connect the signal generator to microphone connector MIC1-2. Key the transmitter by moving the front panel power switch to the “KEY” position. Adjust pot R9 to achieve a deviation of 3 kHz kHz (for a 25 kHz wide channel) or 1.5 kHz (for a 12.5 kHz wide channel). This completes the audio level alignment procedure.

3.4.7 Amplifier Alignment

The RF power output of the amplifier is set to its rated value of 2.0 Watts or 8.0 Watts at the factory. This should not require adjustment under normal circumstances. However, should it be necessary to correct the output power, the 'Output Power Adjustment', which is described in the Amplifier Manual, can be adjusted accordingly. Power adjustment may also be required when the transmitter's operating frequency is changed. When a large frequency change has been programmed into the transmitter, the amplifier should be aligned at the new frequency according to the Amplifier Manual.

3.5 Recommended Test Equipment List

Alignment of the transmitter requires the following test equipment or its equivalent.

Dual Power Supply:	Regulated +9.5 Vdc at 2 A. Regulated +13.8 Vdc at 2 A - Topward TPS-4000
Oscilloscope / Multimeter:	Fluke 97 Scopemeter
Current Meter:	Fluke 75 multimeter
Radio communications test set:	Marconi Instruments 2955R (analog only) Motorola R2670 with Project 25 option
Alignment Tool:	Johanson 4192

It is recommended that the radio communications test set be frequency locked to an external reference (WWVH, GPS, Loran C) so that the high stability oscillator may be accurately set to within its ± 1 ppm frequency tolerance.

3.6 Repair Note

The transmitter is mainly made up of surface mount devices, which should not be removed or replaced using an ordinary soldering iron. Removal and replacement of surface mount components should be performed only with specifically designed surface mount rework and repair stations complete with ElectroStatic Discharge (ESD) protection.

When removing Surface Mount Solder Jumpers, it is recommended to use solder braid in place of manual vacuum type desoldering tools when removing jumpers. This will help prevent damage to the circuit boards.

3.7 Printed Circuit board Numbering Convention

To ease troubleshooting and maintenance procedures, Daniels Electronics Limited has adopted a printed circuit board (PCB) numbering convention in which the last two digits of the circuit board number represent the circuit board version. For example:

- PCB number 43-912010 indicates circuit board version 1.0;
- PCB number 50002-02 indicates circuit board version 2.0.

All PCB's manufactured by Daniels Electronics are identified by one of the above conventions.

This Page Intentionally Left Blank

4 Repeater System Configuration

4.1 Interim Repeater

The MT-4 series Project 25 Interim Digital Receivers will typically be used in a low current repeater configuration with MT-4 series Project 25 Interim Digital Transmitters. In its Interim mode of operation, the receiver can demodulate both FM analog and Project 25 digital signals to baseband audio. This audio can be passed to the Transmitter, where it can be remodulated as either a FM analog or Project 25 digital signal. The voice signal will be repeated in either mode, but other Project 25 digital information such as Network Addressing Code, Talk Group ID, and low speed data will be lost. The simplest way of setting up a repeater system is to connect the receiver to the transmitter through a Radio Interconnect Cable plugged into the CNTL BUS connectors on the front panels of each radio module. This cable routes received audio and the ANALOG_COR* and DIGITAL_COR* signals to the transmitter, which is able to key in either Analog or Project 25 Digital mode.

Most users will normally want to have the digital repeater set up to re-transmit an incoming signal in the same mode as it is received (i.e. normally, you would want a received analog signal to be repeated as analog and a received digital signal to be repeated as digital). In the interim digital repeater, this is accomplished in two steps.

- 1) The receiver determines whether an incoming signal is analog or digital and asserts either the ANALOG_COR* or DIGITAL_COR* signal line to the transmitter.
- 2) When the transmitter senses an ANALOG_COR*, it keys up using one of the 16 channels from Bank A, and when it senses a DIGITAL_COR*, it keys up using one of the 16 channels from Bank B.

The transmitter has two banks of 16 channels each, called Banks A and B. In the interim transmitter, it is suggested that Bank A is used for analog channels and Bank B is used for digital channels. This makes it easy to set up a repeater which re-transmits signals in the same mode in which they were received. It is possible to program any channel in either bank to either analog or digital mode should this be required for special applications. The transmitter has two LEDs labeled A and D, indicating that the transmitter is keyed in either analog or digital mode. In the interim transmitter, these LEDs actually indicate that the transmitter is keyed in Bank A or B. Thus, if Bank A channels are used for digital channels, the Analog LED will light when the transmitter is keyed on a Bank A channel, even though the modulation is digital. This problem will be corrected in the firmware upgrade to fully compliant Project 25 operation.

When setting up the repeater you would typically program the transmitter's Bank A channels with analog settings. Then you would program the corresponding channels in Bank B with the same frequencies but set them up for digital mode. The RSS makes this easier through the "Paste Special to Bank A and Paste Special to Bank B" menu items which allow copying of the frequency, channel name, and timeout value from all the channels in one bank to the corresponding channels in the other bank.

It is important to note that the receiver and transmitter have no connection between them apart from the audio and analog and digital COR* signals. This can lead to confusion since the transmitter doesn't get any information from the receiver about which frequency or channel number to key up on. The transmitter channel is determined by the state of the CSEL0-3 channel select lines, and the receiver can only tell it to key on bank A (analog) or bank B (digital).

4.1.1 Repeater Interconnect Cable Pinout

The cable which is used to interconnect the receiver to a MT-4 Interim Transmitter connects receiver audio and the ANALOG_COR* and DIGITAL_COR* signals to corresponding points in the transmitter. The cable pinout is shown below. Signals shown in brackets are present on the cable, but not used by either the receiver or transmitter for repeater operation.

Receiver End Pin No.	Signal Name	Transmitter End Pin No.
1	(not wired)	1
2	Audio	2
3	ANALOG_COR*	3
4	(LVDS +DATA)	4
5	(LVDS -DATA)	5
6	DIGITAL_COR*	6
7	(+8.8VDC for RPIM)	7
8	(not wired)	8
Shield	(GND)	Shield

4.2 Project 25 Compliant Repeater

The MT-4 Project 25 Interim Digital radios are currently offered in an interim version. Although all the hardware required for fully compliant repeater operation is present in the receivers and transmitters, a firmware upgrade will be required. It is expected that a new version of the Radio Service Software will be released at the same time.

4.3 Repeater System Troubleshooting

Most problems in setting up a repeater are due to the way the transmitter uses bank A and B channels to re-broadcast incoming signals in either analog or digital modes. It is important to note that the receiver and transmitter have no connection between them apart from the demodulated receiver audio, and analog and digital COR* signals. This can lead to confusion since the transmitter doesn't get any information from the receiver about which frequency or channel number to key up on. The transmitter channel is determined by the state of the CSEL0-3 channel select lines, and the receiver can only tell it to key on bank A (analog) or bank B (digital).

Q: Why does the transmitter's Analog LED lighting when keyed on a channel programmed for digital operation?

A: The transmitter has two LEDs labeled A and D, indicating that the transmitter is keyed in either analog or digital mode. In the interim transmitter, these LEDs actually indicate that the transmitter is keyed in Bank A (reserved for analog channels) or B (reserved for digital channels). Thus, if Bank A channels are used for digital channels, the Analog LED will light when the transmitter is keyed on a Bank A channel, even though the modulation is digital. This problem will be corrected in the firmware upgrade to fully compliant Project 25 operation.

Q: Why is the radio not receiving / transmitting on the right frequency?

A: The M-3 motherboard has jumpers that allow one of 16 channels to be selected on a receiver or transmitter. The factory default is to have them all set to ground the channel select lines CSEL0-3, forcing the radio to operate on channel 1. On the receiver there is also a Bank A/B* line which usually floats at +5V, selecting Bank A. There are jumpers inside the receiver and transmitter that may have been removed to disable any or all of these lines. The receiver and transmitter have

separate control of their channel select lines, so changing receiver channels does not affect the transmitter channel.

Q: Why is the transmitter staying on after the receiver signal is removed?

A: The transmitter has a hang timer that keeps it keyed after the receiver signal disappears. This can be used to keep a chain of repeaters up between transmissions. The delay is adjustable from 0 to 3.75 seconds.

Q: What's that noise at the end of a transmission?

A: The transmitter can insert an audible "kerchunk" at the end of a repeater transmission. In Project 25 digital mode, this simulates the effect of the squelch noise, which is heard at the end of an analog repeater transmission. In analog systems, the squelch noise is the sound of the receiver's IF noise before it squelches. This is often useful as a confirmation to repeater users that they have "hit" the repeater. In Project 25 Digital mode, no noise is heard at the end of a transmission due to the all-digital nature of the system, so an artificial noise is added to serve the same purpose. There is a jumper on the transmitter's microprocessor board to disable the kerchunk noise.

Q: Why is the Radio Service Software failing partway through a read or write of the receiver?

A: If the receiver is squelching and unsquelching repeatedly during the read or write operation, the communications bus may be too congested. Try changing channels on the receiver, or disconnect the RF signal source from the receiver during the read or write operation.

Q: Why does the transmitter not transmit with the correct TGID or NAC, or in the wrong mode?

A: In a typical repeater, if the received signal is digital, the transmitter will be keyed from a bank B channel, NOT from bank A, even though the receiver may be receiving on a bank A channel. Make sure that for each transmit channel number, both the A and B bank are programmed with analog information and Project 25 information, respectively.

This Page Intentionally Left Blank

5 ILLUSTRATIONS

5.1 Digital Repeater Transmitter Front Panel

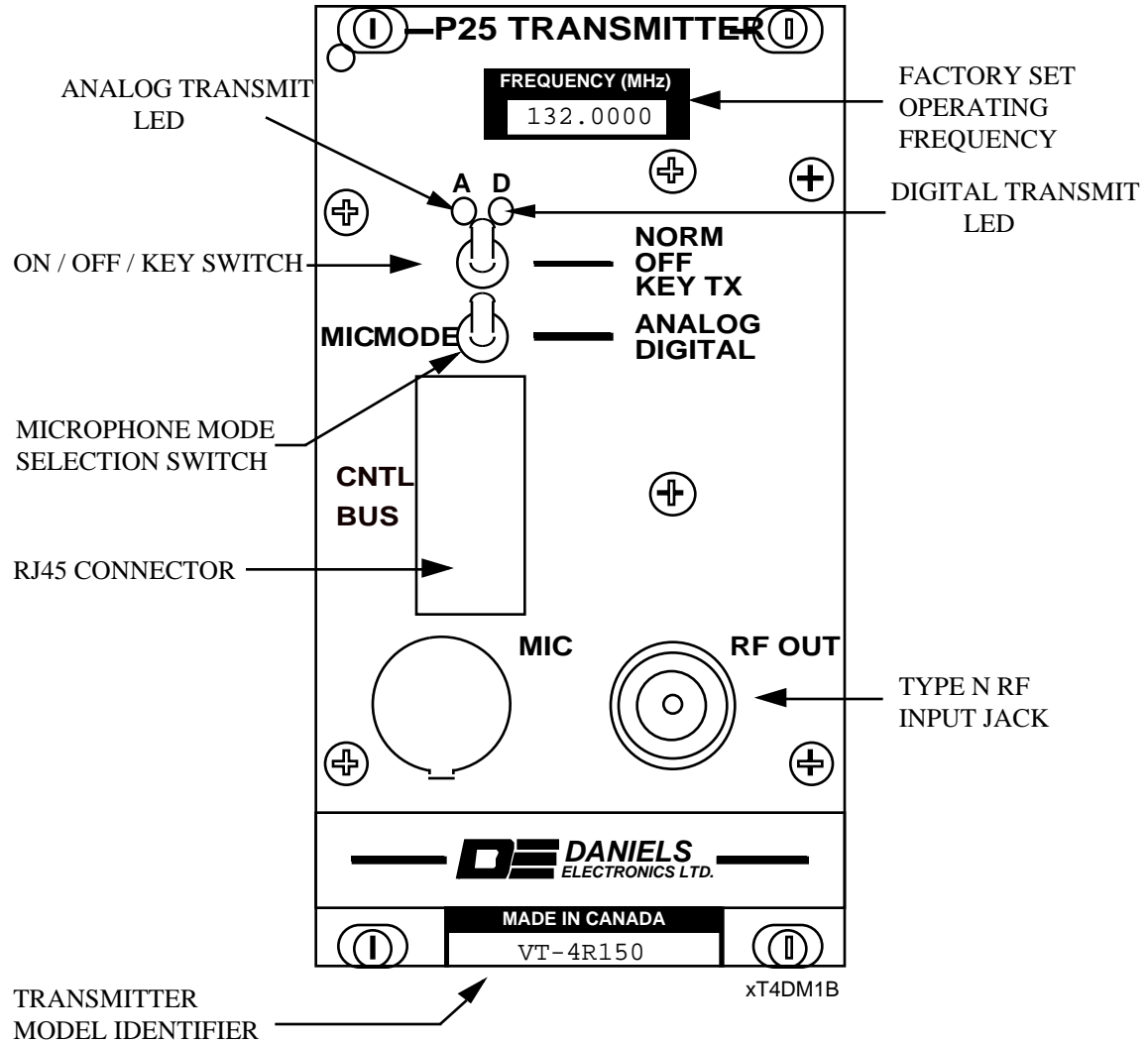

5.2 Digital Repeater Transmitter Exploded View

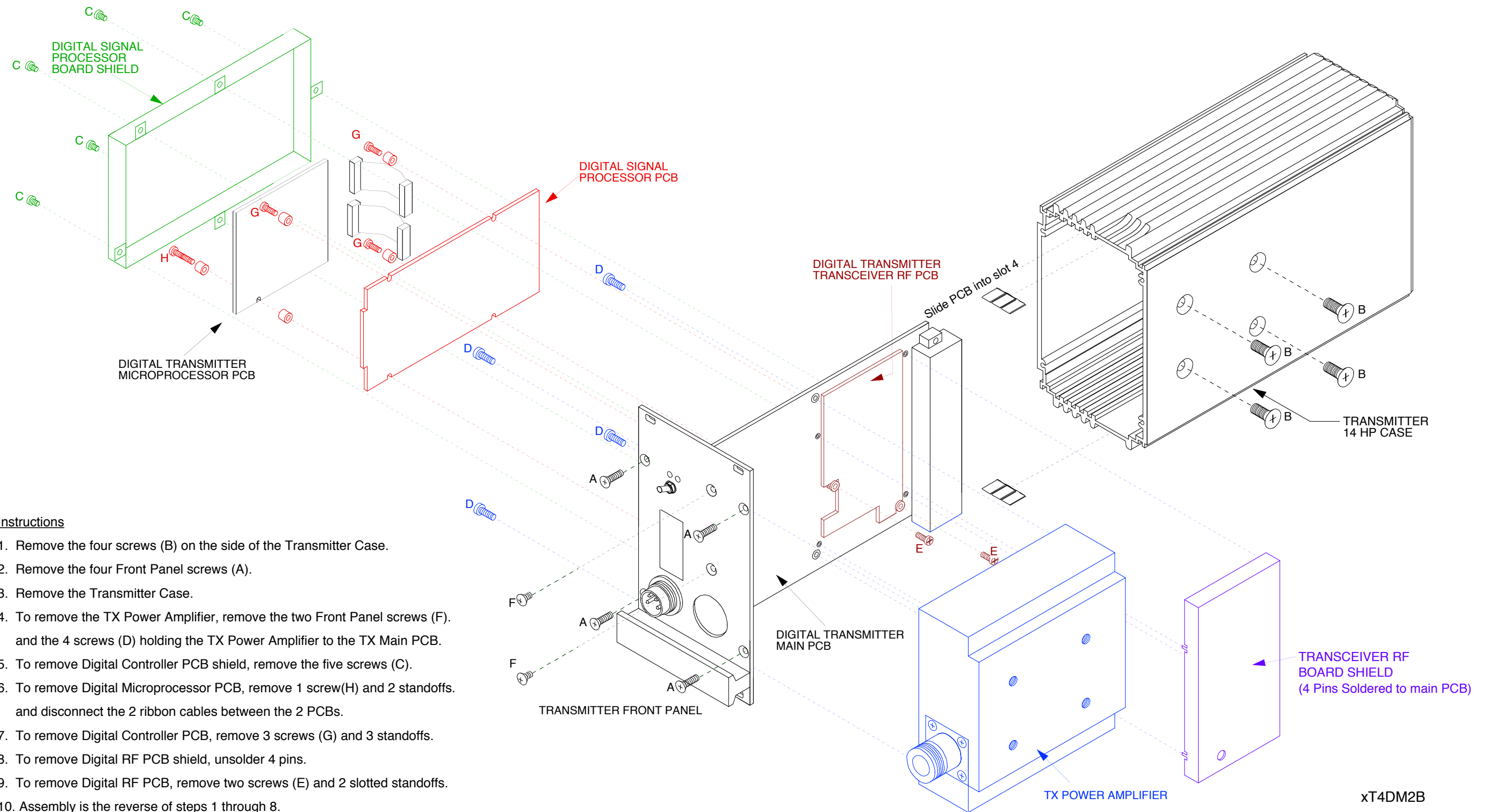

Instructions

1. Remove the four screws (B) on the side of the Transmitter Case.
2. Remove the four Front Panel screws (A).
3. Remove the Transmitter Case.
4. To remove the TX Power Amplifier, remove the two Front Panel screws (F) and the 4 screws (D) holding the TX Power Amplifier to the TX Main PCB.
5. To remove Digital Controller PCB shield, remove the five screws (C).
6. To remove Digital Microprocessor PCB, remove 1 screw(H) and 2 standoffs, and disconnect the 2 ribbon cables between the 2 PCBs.
7. To remove Digital Controller PCB, remove 3 screws (G) and 3 standoffs.
8. To remove Digital RF PCB shield, unsolder 4 pins.
9. To remove Digital RF PCB, remove two screws (E) and 2 slotted standoffs.
10. Assembly is the reverse of steps 1 through 8.

5.3 Digital Repeater Transmitter Block Diagram (Interim Mode)

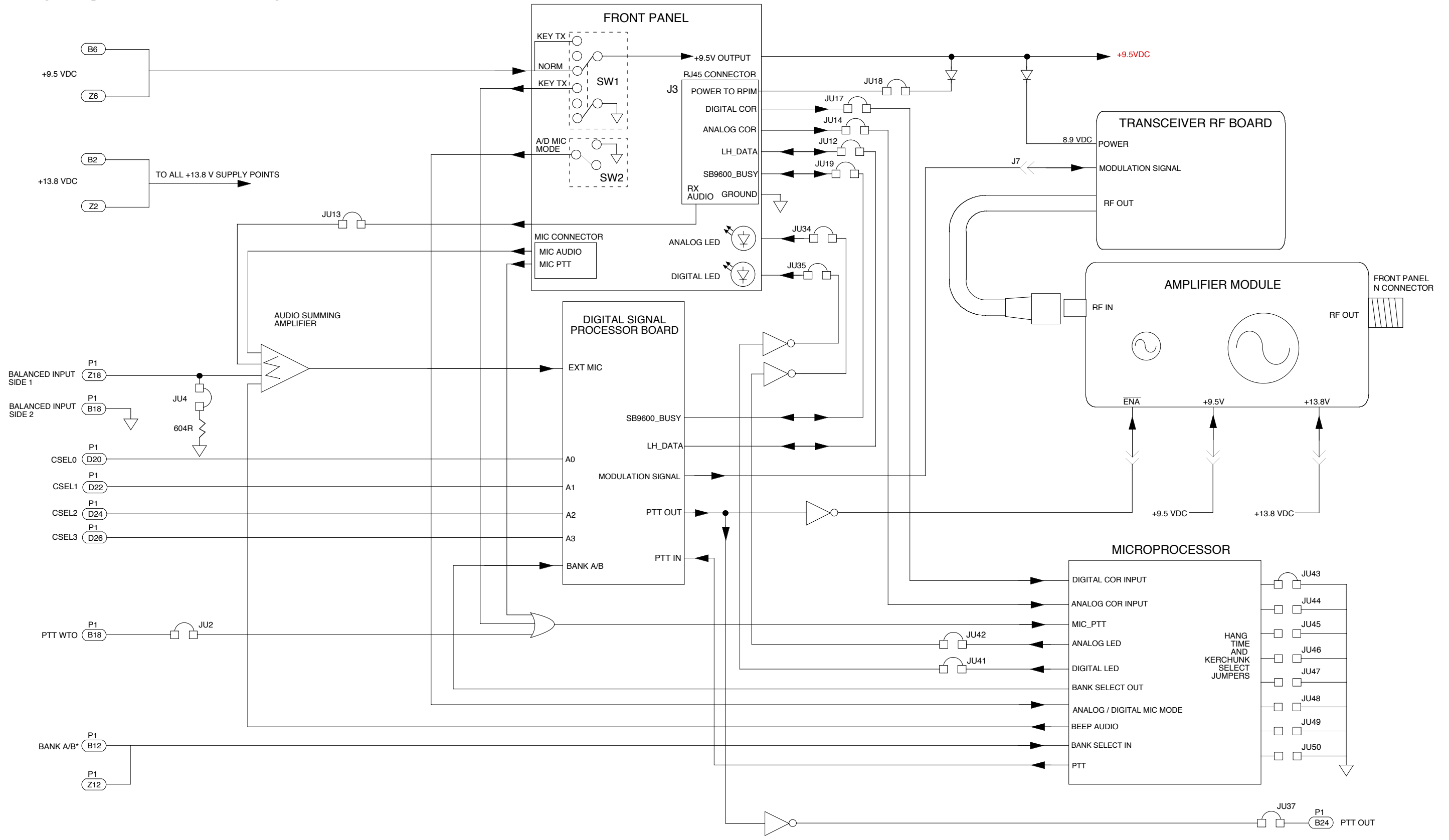

xT4DM3B

5.4 Digital Repeater Transmitter Schematic Diagram

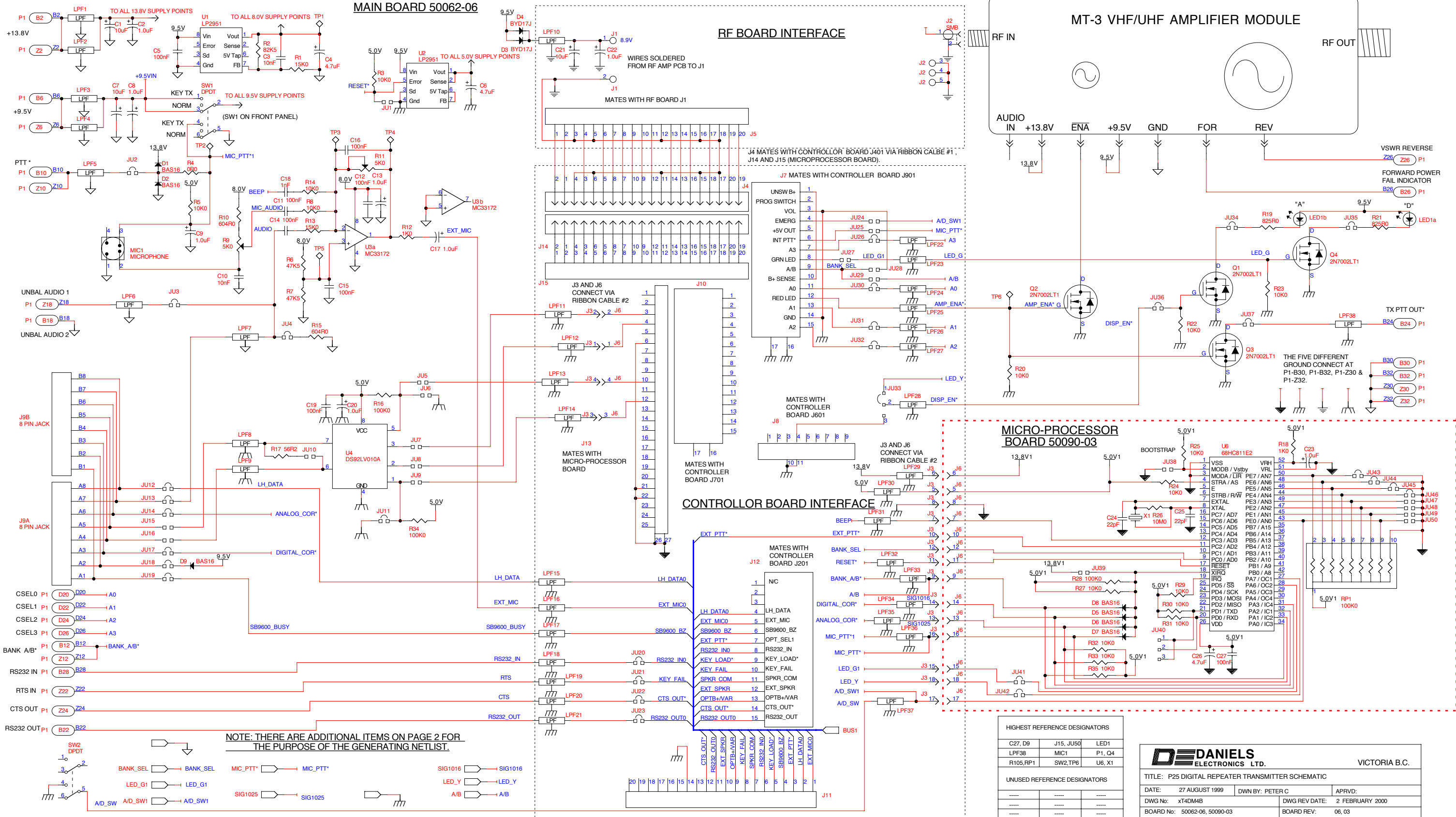

5.5 Digital Repeater Transmitter Main Board Component Layout (Bottom)

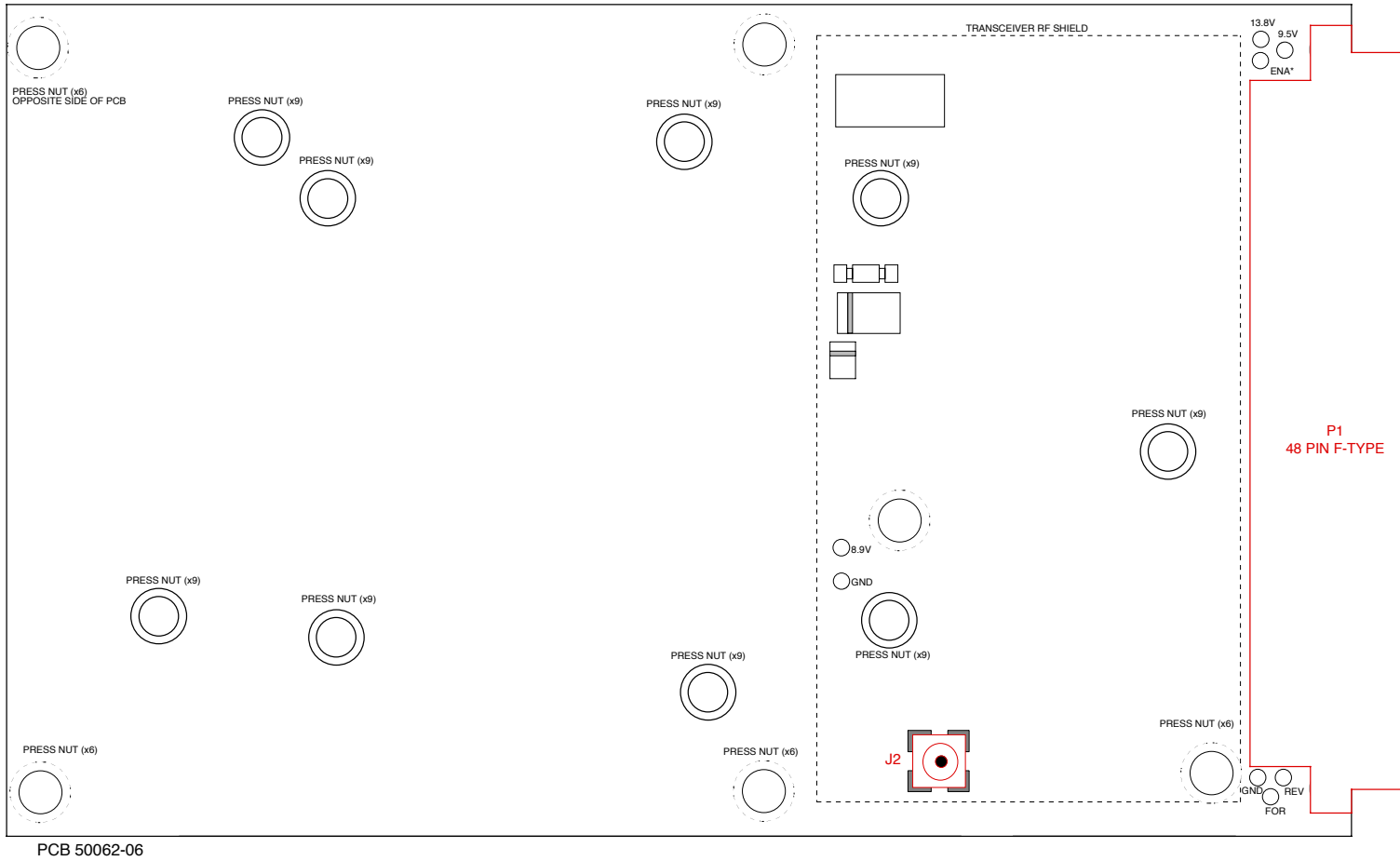

xT4DM5B

5.6 Digital Repeater Transmitter Main Board Component Layout (Top)

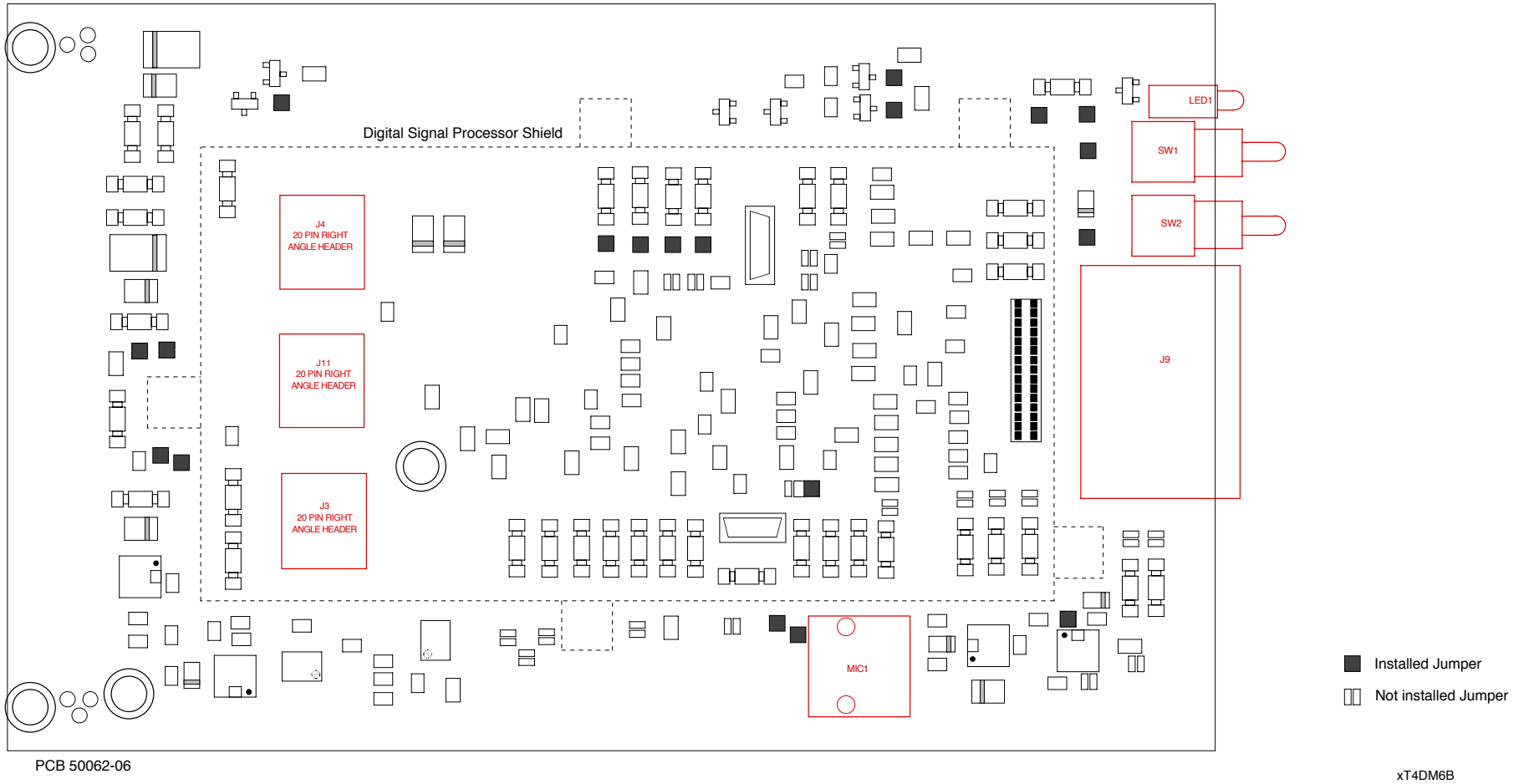

5.7 Digital Repeater Microprocessor Board Component Layout (Bottom)

PCB 50090-03

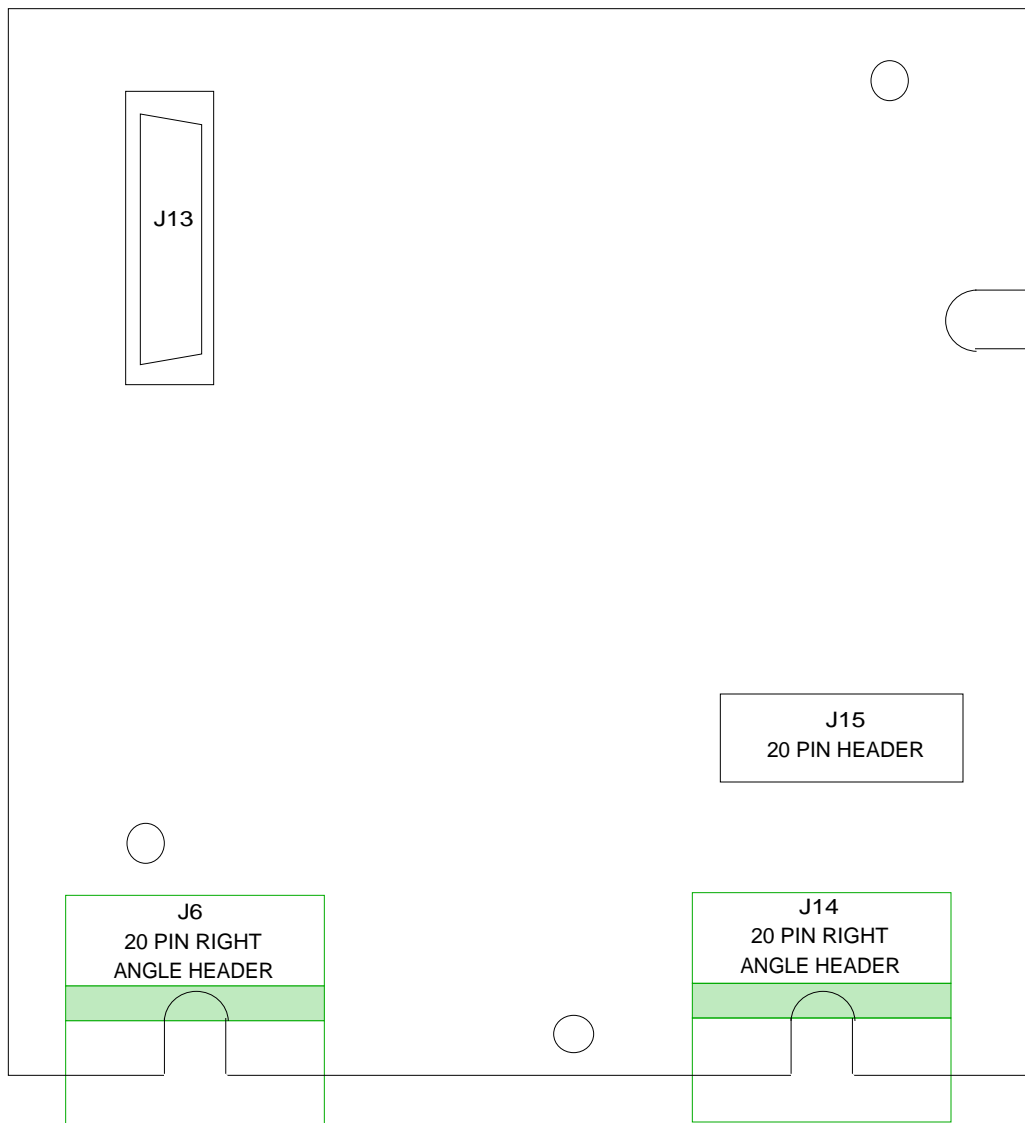

xT4DM7B

5.8 Digital Repeater Microprocessor Board Component Layout (Top)

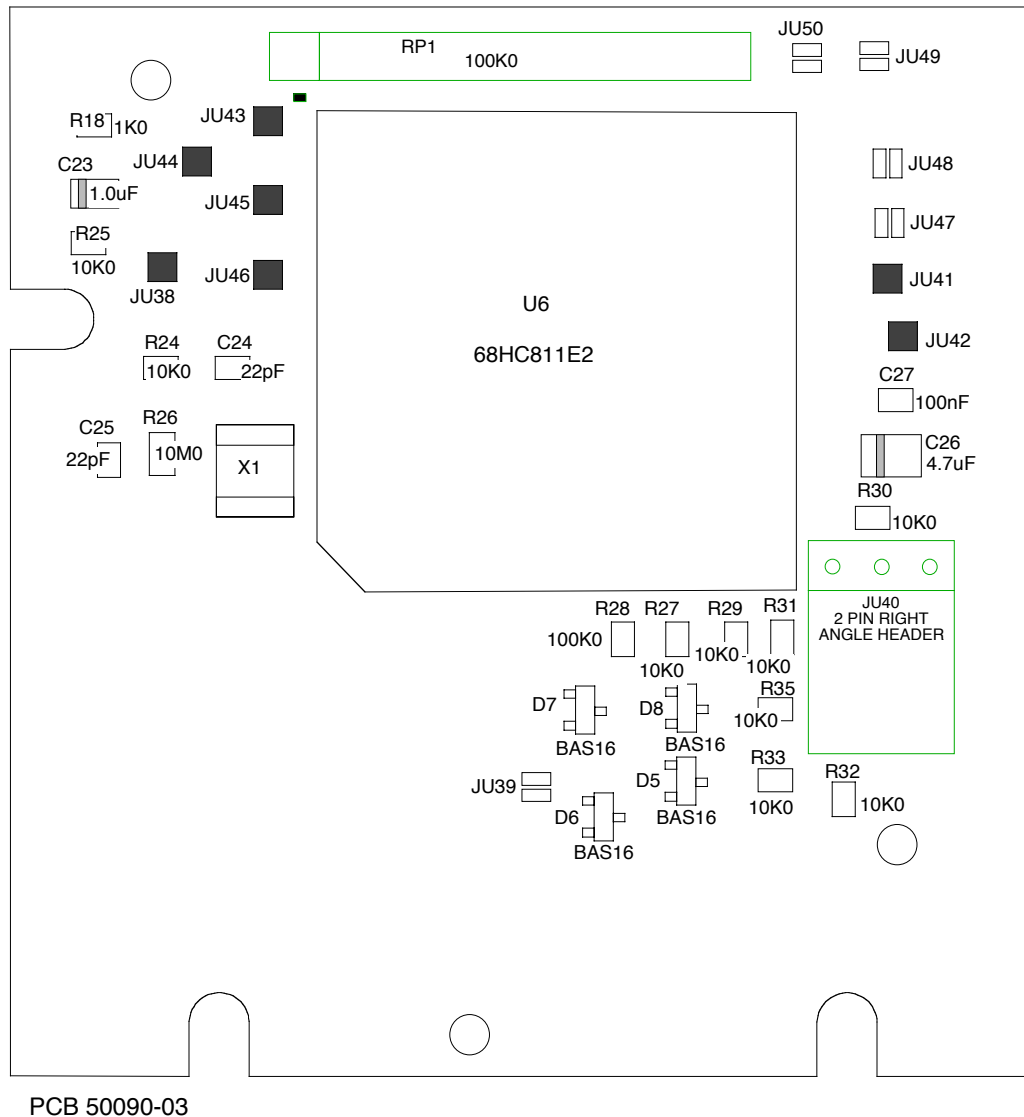

xT4DM8B

6 PARTS LIST

6.1 Digital Repeater Transmitter Main Board Parts List

6.1.1 Digital Repeater Transmitter Main Board Electrical Parts List

Ref Desig	Description	Part No.
C1	CAP., SM, 10uF TANT., 20%, 35V	1055-6D106K35
C2	CAP., SM, 1.0uF TANT., 20%, 35V	1055-5B105M35
C3	CAP., SM, 10nF CER,0805,X7R,50V	1008-4A103K5R
C4	CAP., SM, 4.7uF TANT., 10%, 16V	1055-5B475K16
C5	CAP., SM, 100nF CER., 0805, X7R, 50V	1008-5A104K5R
C6	CAP., SM, 4.7uF TANT., 10%, 16V	1055-5B475K16
C7	CAP., SM, 10uF TANT., 20%, 35V	1055-6D106K35
C8	CAP., SM, 1.0uF TANT., 20%, 35V	1055-5B105M35
C9	CAP., SM, 1.0uF TANT., 20%, 16V	1055-5A105M16
C10	CAP., SM, 10nF CER,0805,X7R,50V	1008-4A103K5R
C11, C12	CAP., SM, 100nF CER., 0805, X7R, 50V	1008-5A104K5R
C13	CAP., SM, 1.0uF TANT., 20%, 16V	1055-5A105M16
C14, C15	CAP., SM, 100nF CER., 0805, X7R, 50V	1008-5A104K5R
C16	CAP., SM, 1nF CER,0805,X7R,50V	1008-3A102K5R
C17	CAP., SM, 1.0uF TANT., 20%, 16V	1055-5A105M16
C18, C19	CAP., SM, 100nF CER., 0805, X7R, 50V	1008-5A104K5R
C20	CAP., SM, 1.0uF TANT., 20%, 16V	1055-5A105M16
C21	CAP., SM, 10uF TANT., 20%, 35V	1055-6D106K35
C22	CAP., SM, 1.0uF TANT., 20%, 35V	1055-5B105M35
D1, D2	DIODE, BAS16 SWITCHING, SOT23	2100-BAS16000
D3, D4	DIODE, BYD17J RECTIFIER,SOD87	2101-BYD17J00
D9	DIODE, BAS16 SWITCHING, SOT23	2100-BAS16000
J2	CONN., SMB, JACK,PC MNT,STRHT.	5122-J20S00BG
J3, J4	HEADER, 2x10, .050", R/A, Au	5028-GH127E10
J5	HEADER, SM,2x10,.050",DV,W/PIN	5028-GH127F10
J7	PLUG, SM,15 CCT,1.00mm,BRD-BRD	5028-DP100S15
J8	PLUG, SM, 9 CCT,1.00mm,BRD-BRD	5028-DP100S09
J9	JACK, DUAL RJ45,8POS,PCB,SHLD.	5047-2RJ45JGS
J11	HEADER, 2x10, .050", R/A, Au	5028-GH127E10
J12	SOCKET, SM,2x15,.050",VERT.,Au	5028-KS127A15
LED1	LED, GREEN, BILEVEL, RA PC MNT	2017-091N12GN
LPF1	FILTER, SM, EM1/LPF, 360pF,FER	1306-T361F2D5
LPF2	FILTER, SM, EM1/LPF, 360pF,FER	1306-T361F2D5
LPF3	FILTER, SM, EM1/LPF, 360pF,FER	1306-T361F2D5
LPF4	FILTER, SM, EM1/LPF, 360pF,FER	1306-T361F2D5
LPF5	FILTER, SM, EM1/LPF, 360pF,FER	1306-T361F2D5
LPF6	FILTER, SM, EM1/LPF, 360pF,FER	1306-T361F2D5
LPF7	FILTER, SM, EM1/LPF, 360pF,FER	1306-T361F2D5
LPF8	FILTER, SM, EM1/LPF, 360pF,FER	1306-T361F2D5
LPF9	FILTER, SM, EM1/LPF, 360pF,FER	1306-T361F2D5
LPF10	FILTER, SM, EM1/LPF, 360pF,FER	1306-T361F2D5

Ref Desig	Description	Part No.
LPF11	FILTER, SM, EM1/LPF, 360pF,FER	1306-T361F2D5
LPF12	FILTER, SM, EM1/LPF, 360pF,FER	1306-T361F2D5
LPF13	FILTER, SM, EM1/LPF, 360pF,FER	1306-T361F2D5
LPF14	FILTER, SM, EM1/LPF, 360pF,FER	1306-T361F2D5
LPF15	FILTER, SM, EM1/LPF, 360pF,FER	1306-T361F2D5
LPF16	FILTER, SM, EM1/LPF, 360pF,FER	1306-T361F2D5
LPF17	FILTER, SM, EM1/LPF, 360pF,FER	1306-T361F2D5
LPF18	FILTER, SM, EM1/LPF, 360pF,FER	1306-T361F2D5
LPF19	FILTER, SM, EM1/LPF, 360pF,FER	1306-T361F2D5
LPF20	FILTER, SM, EM1/LPF, 360pF,FER	1306-T361F2D5
LPF21	FILTER, SM, EM1/LPF, 360pF,FER	1306-T361F2D5
LPF22	FILTER, SM, EM1/LPF, 360pF,FER	1306-T361F2D5
LPF23	FILTER, SM, EM1/LPF, 360pF,FER	1306-T361F2D5
LPF24	FILTER, SM, EM1/LPF, 360pF,FER	1306-T361F2D5
LPF25	FILTER, SM, EM1/LPF, 360pF,FER	1306-T361F2D5
LPF26	FILTER, SM, EM1/LPF, 360pF,FER	1306-T361F2D5
LPF27	FILTER, SM, EM1/LPF, 360pF,FER	1306-T361F2D5
LPF28	FILTER, SM, EM1/LPF, 360pF,FER	1306-T361F2D5
LPF29	FILTER, SM, EM1/LPF, 360pF,FER	1306-T361F2D5
LPF30	FILTER, SM, EM1/LPF, 360pF,FER	1306-T361F2D5
LPF31	FILTER, SM, EM1/LPF, 360pF,FER	1306-T361F2D5
LPF32	FILTER, SM, EM1/LPF, 360pF,FER	1306-T361F2D5
LPF33	FILTER, SM, EM1/LPF, 360pF,FER	1306-T361F2D5
LPF34	FILTER, SM, EM1/LPF, 360pF,FER	1306-T361F2D5
LPF35	FILTER, SM, EM1/LPF, 360pF,FER	1306-T361F2D5
LPF36	FILTER, SM, EM1/LPF, 360pF,FER	1306-T361F2D5
LPF37	FILTER, SM, EM1/LPF, 360pF,FER	1306-T361F2D5
LPF38	FILTER, SM, EM1/LPF, 360pF,FER	1306-T361F2D5
MIC1	HEADER, .1",4CCT,R/A PCB,.120"	5021-H604L025
P1	CONNECTOR, F48 MALE, RA PCB	3720-6048M0RA
PCB	PCB, MAIN, P25 REPTR. TRANSMTR	4421-10500626
Q1 – Q4	MOSFET, 2N7002LT1 N-CHAN,SOT23	2142-2N7002L0
R1	RES., SM, 15K0 0805, 1%,100ppm	1150-4A1502FP
R2	RES., SM, 82K5 0805, 1%,100ppm	1150-4A8252FP
R3	RES., SM, 10K0 0805, 1%,100ppm	1150-4A1002FP
R4	RES., SM, 0R0 ZERO OHM JUMPER,1206	1150-0B0R0000
R5	RES., SM, 10K0 0805, 1%,100ppm	1150-4A1002FP
R6, R7	RES., SM, 47K5 0805, 1%,100ppm	1150-4A4752FP
R8	RES., SM, 10K0 0805, 1%,100ppm	1150-4A1002FP
R9	POT., SM, 5K0 12T, TOP ADJUST	1172-M20502W5
R10	RES., SM, 604R 1206, 1%,100ppm	1150-2B6040FP
R11	POT., SM, 5K0 12T, TOP ADJUST	1172-M20502W5
R12	RES., SM, 1K0 0805, 1%,100ppm	1150-3A1001FP
R13	RES., SM, 15K0 0805, 1%,100ppm	1150-4A1502FP
R14	RES., SM, 10K0 0805, 1%,100ppm	1150-4A1002FP
R15	RES., SM, 604R 1206, 1%,100ppm	1150-2B6040FP
R16	RES., SM, 100K0 0805, 1%,100ppm	1150-5A1003FP

Ref Desig	Description	Part No.
R17	RES., SM, 56R2 1206, 1%,100ppm	1150-1B56R2FP
R19	RES., SM, 825R 1206, 1%,100ppm	1150-2B8250FP
R20	RES., SM, 10K0 0805, 1%,100ppm	1150-4A1002FP
R21	RES., SM, 825R 1206, 1%,100ppm	1150-2B8250FP
R22, R23	RES., SM, 10K0 0805, 1%,100ppm	1150-4A1002FP
R34	RES., SM, 100K0 0805, 1%,100ppm	1150-5A1003FP
R35	RES., SM, 10K0 0805, 1%,100ppm	1150-4A1002FP
R36	RES., SM, 0R0 ZERO OHM JUMPER,0805	1150-0A0R0000
R37	RES., SM, 0R0 ZERO OHM JUMPER,1206	1150-0B0R0000
R38, R39	RES., SM, 0R0 ZERO OHM JUMPER,0805	1150-0A0R0000
R40, R41	RES., SM, 0R0 ZERO OHM JUMPER,1206	1150-0B0R0000
R42	RES., SM, 0R0 ZERO OHM JUMPER,0805	1150-0A0R0000
R43 - R46	RES., SM, 0R0 ZERO OHM JUMPER,1206	1150-0B0R0000
R47 - R51	RES., SM, 0R0 ZERO OHM JUMPER,0805	1150-0A0R0000
R52	RES., SM, 0R0 ZERO OHM JUMPER,1206	1150-0B0R0000
R53, R54	RES., SM, 0R0 ZERO OHM JUMPER,0805	1150-0A0R0000
R55 - R57	RES., SM, 0R0 ZERO OHM JUMPER,1206	1150-0B0R0000
R58 - R62	RES., SM, 0R0 ZERO OHM JUMPER,0805	1150-0A0R0000
R63 - R65	RES., SM, 0R0 ZERO OHM JUMPER,1206	1150-0B0R0000
R66, R67	RES., SM, 0R0 ZERO OHM JUMPER,0805	1150-0A0R0000
R68	RES., SM, 0R0 ZERO OHM JUMPER,1206	1150-0B0R0000
R69	RES., SM, 0R0 ZERO OHM JUMPER,0805	1150-0A0R0000
R70	RES., SM, 0R0 ZERO OHM JUMPER,1206	1150-0B0R0000
R71, R72	RES., SM, 0R0 ZERO OHM JUMPER,0805	1150-0A0R0000
R73	RES., SM, 0R0 ZERO OHM JUMPER,1206	1150-0B0R0000
R74	RES., SM, 0R0 ZERO OHM JUMPER,0805	1150-0A0R0000
R75 - R83	RES., SM, 0R0 ZERO OHM JUMPER,1206	1150-0B0R0000
R84	RES., SM, 0R0 ZERO OHM JUMPER,0805	1150-0A0R0000
R85, R86	RES., SM, 0R0 ZERO OHM JUMPER,1206	1150-0B0R0000
R87	RES., SM, 0R0 ZERO OHM JUMPER,0805	1150-0A0R0000
R88, R89	RES., SM, 0R0 ZERO OHM JUMPER,1206	1150-0B0R0000
R90, R91	RES., SM, 0R0 ZERO OHM JUMPER,0805	1150-0A0R0000
R92	RES., SM, 0R0 ZERO OHM JUMPER,1206	1150-0B0R0000
R93, R94	RES., SM, 0R0 ZERO OHM JUMPER,0805	1150-0A0R0000
R95	RES., SM, 0R0 ZERO OHM JUMPER,1206	1150-0B0R0000
R96 - R98	RES., SM, 0R0 ZERO OHM JUMPER,0805	1150-0A0R0000
R99	RES., SM, 0R0 ZERO OHM JUMPER,1206	1150-0B0R0000
R100	RES., SM, 0R0 ZERO OHM JUMPER,1206	1150-0B0R0000
R101	RES., SM, 0R0 ZERO OHM JUMPER,1206	1150-0B0R0000
R102	RES., SM, 0R0 ZERO OHM JUMPER,1206	1150-0B0R0000
R103	RES., SM, 0R0 ZERO OHM JUMPER,0805	1150-0A0R0000
R104	RES., SM, 0R0 ZERO OHM JUMPER,1206	1150-0B0R0000
R105	RES., SM, 0R0 ZERO OHM JUMPER,1206	1150-0B0R0000
SW1	SWITCH, TOG, DPDT ON-OFF-ON,PC,RA	5215-T2030A01
SW2	SWITCH, TOG./SPDT,O-N-O,PCB/RA	5215-T1011A02
U1	IC, LP2951 PROG. VOLT REG,SO-8	2305-29510N08
U2	IC, LP2951 PROG. VOLT REG,SO-8	2305-29510N08
U3	IC, MC33172 DUAL OP AMP, SO-8	2302-33172N08
U3	IC, MC33172 DUAL OP AMP, SO-8	2302-33172N08
U4	IC, DS92LV010A,BUS TRNCVR,SO-8	2378-92010N08

6.1.2 Digital Repeater Transmitter Main Board Mechanical Parts List

Description	Part No.	Qty.
CABLE, CUSTOM, RJ45P-RJ45P, 20CM	CBLC46-12506020	1
CABLE, CUSTOM, RJ45P-RJ45P, 50CM	CBLC46-12506050	1
CABLE STRIP,2x10 DUAL SOCK.,3"	5029-C10D030N	2
CABLE,SMB PL-SMB PL,RG316,RA-STR	\$7910-WP0WSO12	1
CASE, 14HP RF PLUG-IN, MT-3 TX	3702-62502010	1
COAX, CONFORMABLE,50 OHM,0.083, 2.2cm	7482-5024T083	1
COAX, CONFORMABLE,50 OHM,0.083, 2.8cm	7482-5024T083	1
FASTENER, QUICK RELEASE	3702-10000120	4
GASKET, BeCu, .188"W, ADHESIVE	5631-20020188	3
GASKET, BeCu,3FINGER.,.25",CLIP	5630-12023250	2
HANDLE, FRONT PANEL, 14HP, GREY	3702-10000614	1
HEADER, TH, 2X15 POS., .05"X0.05" PITCH	5026-PB127B15	1
HOUSING CRIMP, 4 POS., 0.1" PITCH	5021-HF04L002	1
LABEL/LEXAN, 14HP, UHF: BLACK	3536-10131410	UHF: 1
LOCKWASHER, M3, SPLIT,A2 STEEL	5814-3M0LK00S	4
MIC CONN, 4 PIN MALE, BLACK	5040-114ST0BK	1
NAMEPLATE, BLANK, 14HP, ALUM.	3702-10001214	1
NUT, PRESS,M2.5,5.6mmOD,PC MNT	5833-T2M55615	13
NUT, M2.5, SQUARE-5mm, ZINC	5813-2M5SQ50Z	2
PANEL, REAR, POS.4, 14HP EXTRSN.	3702-63002101	1
PANEL/FRONT, W/IDENT: TX-4R	3802-61002120	1
SCREW, M3 X 6 PAN/PHIL, A2	5812-3M0PP06S	4
SCREW, M3 X 6 PAN/PHIL, A2	5812-3M0PP06S	4
SCREW, M5 X 8 FLAT/PHIL, A2	5812-5M0FP08S	4
SCREW, M2.5 x 10 PAN/PHIL, A2	5812-2M5PP10S	7
SCREW, M2.5 x 12 FLAT/PHIL, A2	5812-2M5FP12S	2
SCREW, M2.5 x 16 PAN/PHIL, A2	5812-2M5PP16S	1
SCREW, M2.5 x 3 PAN/PHIL, A2	5812-2M5PP03S	5
SCREW, M3 x 6,OVAL C/S/PHIL,A2	5812-3M0VP06S	2
SCREW, M3 x8,OVAL C/S/PHIL,A2	5812-3M0VP08S	4
SHIELD, CONTROLLER BOARD, DIG TX	3702-67402105	1
SHIELD, RF BOARD, DIG TX	3702-67402110	1
SLOTTED SPACER, 5mmOD, 7.8mm L,M2.5	5930-5A065CA1	2

Description	Part No.	Qty.
SPACER, 5mmOD, 6mm L,M2.5	5920-5A0600C01	4
SPACER, 5mmOD,5.2mmL,2.6mmHOLE	5920-5A052C01	1
TERMINAL, CRIMP, FEM.,22-24,Au,MOLEX 16-02-0103	5021-TF22B002	4
TUBING, PVC-105C, 8 AWG, CLEAR, 10cm	7602-105C08CL	1
WIRE, PVC/STRAND., 22AWG, BLUE, 16cm	7110-22S07306	1
WIRE, TFE/STRAND., 24AWG, ORG., 14cm	7121-24S19363	1
WIRE, PVC/STRAND., 22AWG, ORG., 15cm	7110-22S07303	1
WIRE, TFE/STRAND., 24AWG, RED, 14cm	7121-24S19362	1
WIRE, PVC/STRAND., 22AWG, RED, 19cm	7110-22S07302	1
WIRE, TFE/STRAND., 24AWG, VIO., 14cm	7121-24S19367	1
WIRE, PVC/STRAND., 22AWG,BLACK, 14cm	7110-22S07300	1
WIRE, PVC/STRAND., 22AWG,BROWN, 14cm	7110-22S07301	1
WIRE, TFE/STRAND.,24AWG,YELLOW, 14cm	7121-24S19364	1
WIRE, PVC/STRAND.,22AWG,YELLOW, 12cm	7110-22S07304	1
WIRE, TFE/STRAND., 24AWG, RED, 8cm	7121-24S19362	1
WIRE, TFE/STRAND., 24AWG,BLACK, 8cm	7121-24S19360	1

6.2 Digital Repeater Microprocessor Board Parts List

6.2.1 Digital Repeater Microprocessor Board Electrical Parts List

Ref	Description	Part No.
C23	CAP., SM, 1.0uF TANT., 20%, 16V	1055-5A105M16
C24	CAP., SM, 22pF CER., 0805, C0G	1008-1A220J1G
C25	CAP., SM, 22pF CER., 0805, C0G	1008-1A220J1G
C26	CAP., SM, 4.7uF TANT., 10%, 16V	1055-5B475K16
C27	CAP., SM, 100nF CER., 0805, X7R, 50V	1008-5A104K5R
D5 – D8	DIODE, BAS16 SWITCHING, SOT23	2100-BAS16000
J6	HEADER, 2x10, .050", R/A, Au	5026-GH127E10
J13	PLUG, SM,25 CCT,1.00mm,BRD-BRD	5028-DP100R25
J14	HEADER, 2x10, .050", R/A, Au	5026-GH127E10
J15	HEADER, SM,2x10,.050",DV,W/PIN	5028-GH127F10
JU40	HEADER, .1", R/A,1 ROW x 3 PIN	5010-H103RANL
PCB	PCB, RTR. DIG. TX μ -PROCESSOR BOARD, 50090-03	4421-11500903
R18	RES., SM, 1K0 0805, 1%,100ppm	1150-3A1001FP
R24	RES., SM, 10K0 0805, 1%,100ppm	1150-4A1002FP
R25	RES., SM, 10K0 0805, 1%,100ppm	1150-4A1002FP
R26	RES., SM, 10M0 1206, 5%,400ppm	1151-7B0106JG
R27	RES., SM, 10K0 0805, 1%,100ppm	1150-4A1002FP
R28	RES., SM, 100K0 0805, 1%,100ppm	1150-5A1003FP
R29	RES., SM, 10K0 0805, 1%,100ppm	1150-4A1002FP
R30	RES., SM, 10K0 0805, 1%,100ppm	1150-4A1002FP

Ref Desig	Description	Part No.
R31	RES., SM, 10K0 0805, 1%,100ppm	1150-4A1002FP
R32	RES., SM, 10K0 0805, 1%,100ppm	1150-4A1002FP
R33	RES., SM, 10K0 0805, 1%,100ppm	1150-4A1002FP
R35	RES., SM, 10K0 0805, 1%,100ppm	1150-4A1002FP
RP1	RES., SIP, 100K0 2%,10PIN,#1COM	1160-5B104G10
U1	IC, 68HC811E2, MIC/CTR, PLCC52	2380-68811P52
X1	RESONATOR, SM, 8.0MHz, CERAMIC	1575-8001816A

6.2.2 Digital Transmitter Additional PCBs

Ref Desig	Description	Part No.
PCB	TRANSCEIVER RF MODULE, P25, UHG 403-470 MHz	A13-XCVR-00
PCB	DIGITAL SIGNAL PROCESSOR, P25	A57-DSP-00

7 REVISION HISTORY

ISSUE	DATE	DESCRIPTION AND (REASON)
1	July 00	• First Issue

This Page Intentionally Left Blank