



**Applicant:** Daniels Electronics Ltd.  
43 Erie St  
Victoria, BC V8V 1P8

**Equipment Under Test:** AMP-2/450 30 Watt UHF Power Amplifier  
406.1-470 MHz

**FCC ID:** H4JAMP-2-450

**In Accordance With:** 47 CFR Parts 22, 80 & 90

**Tested By:** Daniels Electronics Ltd.  
43 Erie St  
Victoria, BC, V8V 1P8

And

**FCC Registration Number** Acme Testing Co.  
2002 Valley Highway  
Acme, WA, 98220-0003  
90420

**Authorized By:**

A handwritten signature in black ink that reads 'Dale Reitsma'.

Dale Reitsma, B.Eng., D&D Manager

**Testing Verified By:**

A handwritten signature in blue ink that reads 'Michael J. Cyr'.

Michael J. Cyr, B.Eng., Communication System Designer

**Date:** 3 March 2005

**Total Number of Pages:** 36

## **Table of Contents**

<b>1.</b>	<b>Summary of Test Data .....</b>	<b>3</b>
<b>2.</b>	<b>General Equipment Specifications .....</b>	<b>4</b>
<b>3.</b>	<b>RF Output Power .....</b>	<b>5</b>
<b>4.</b>	<b>Occupied Bandwidth .....</b>	<b>6</b>
<b>5.</b>	<b>Spurious Emissions at Antenna Terminals .....</b>	<b>19</b>
<b>6.</b>	<b>Field Strength of Spurious Emissions .....</b>	<b>32</b>
<b>7.</b>	<b>Block Diagrams .....</b>	<b>33</b>
<b>8.</b>	<b>Test Equipment List .....</b>	<b>34</b>
	<b>APPENDIX A: H4JAMP-2-450 - Radiated Emissions Report</b>	

## 1. Summary of Test Data

Name of Test	Para No.	Result
RF Power Output	2.1046	Complies
Occupied Bandwidth	2.1049	Complies
Spurious Emissions at Antenna Terminals	2.1051	Complies
Field Strength of Spurious Emissions	2.1053	Complies
Frequency Stability	2.1055	N/A (3)

### Notes:

- 1) This application is for a New Approval of Daniels Electronics Ltd. **AMP-2/450 30 Watt UHF Power Amplifier**, operating in the 406.1-470 MHz frequency band of the Land Mobile Services and approved by the FCC under FCC ID: **H4JAMP-2-450** for emission designators F1D, F1E, F3D, F3E, G3E.
- 2) The AMP-2/450-30 operates over the frequency range of 406.1 – 470 MHz, with specific intended operation in the 406.1 - 430 MHz and 450 – 470 MHz sub-frequency bands. Low band edge, high band edge and mid-band test frequencies have been selected from within these two sub-frequency bands as follows:
  - a. 407.000 MHz (Low Band Edge)
  - b. 451.000 MHz (Mid Band)
  - c. 470.000 MHz (High Band Edge)
- 3) The AMP-2/450-30 amplifier operates on a single channel only, with RF input provided via coaxial connection from an FCC approved exciter. The RF input frequency is not translated; therefore frequency stability tests are not applicable.

### General

These tests were conducted on a sample of the equipment for the purpose of demonstrating compliance with FCC Parts 22, 80, & 90. All measurements are traceable to national standards.

### Test Conditions:

**Indoor**      Temperature: 23°C  
                  Humidity: 30%

## 2. General Equipment Specifications

<b>Manufacturer:</b>	Daniels Electronics Ltd.	
<b>Model Number(s):</b>	AMP-2/450-30	(406.1-450 MHz)
<b>Serial Numbers of EUTs:</b>	D&D 10011	(407 MHz)
	D&D 10009	(451 MHz)
	R&D 10002	(470 MHz)
<b>Starting Date of Testing:</b>	24 December 2004	
<b>Frequency Range:</b>	406.1-470 MHz	(AMP-2/450-30)
<b>Rated RF Output:</b>	20-30W	
<b>Amplifier Gain (Rated):</b>	13dB	
<b>Emission Designators:</b>	F1D, F1E, F3D, F3E, G3E	

**3. RF Output Power** (47 CFR §2.1046)

**Test Results:** Complies

Each individual frequency is factory set for 30W (44.8dBm). All three frequencies, center and band edges (407, 451, 470 MHz), were therefore within  $\pm 1$ dB of the manufacturer's rating.

**EUT Model #:** AMP-2/450-30

**Measurement Data:** Rated Power = 30W (44.8dBm)

Frequency (MHz)	Rated Power (dBm)	Measured Power (dBm)
407	44.8	44.8
451	44.8	44.8
470	44.8	44.8

**4. Occupied Bandwidth** (47 CFR §2.1049)

**Test Results:** Complies

The occupied bandwidth was measured by comparing the input and output signals to each other. This determined if PA amplification degraded the signal in any way.

**EUT Model #:** AMP-2/450-30

**Test Data:** See following graphs:

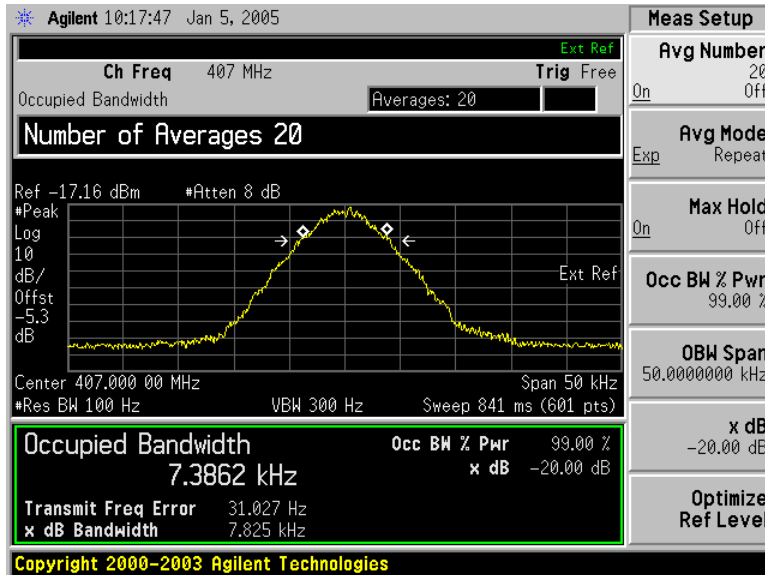

Exciter Output (Amplifier Input)  
407 MHz  
F1D Modulation

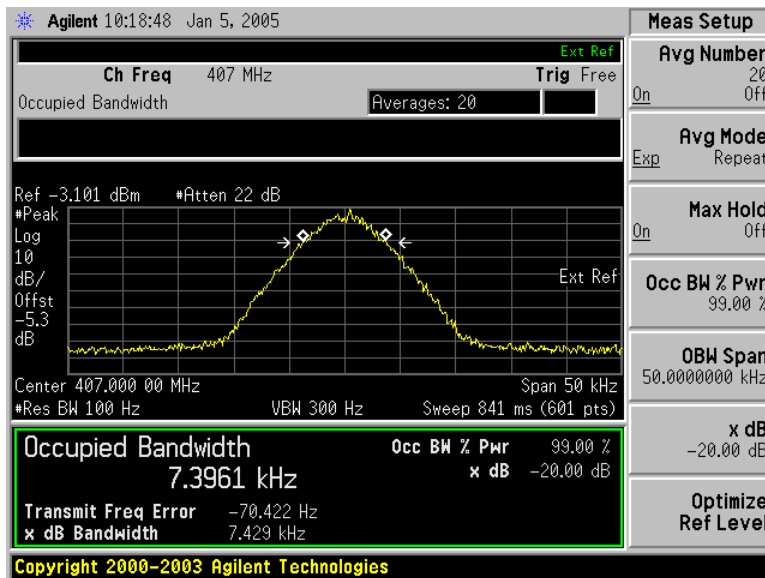

Amplifier Output  
407 MHz  
F1D Modulation Input

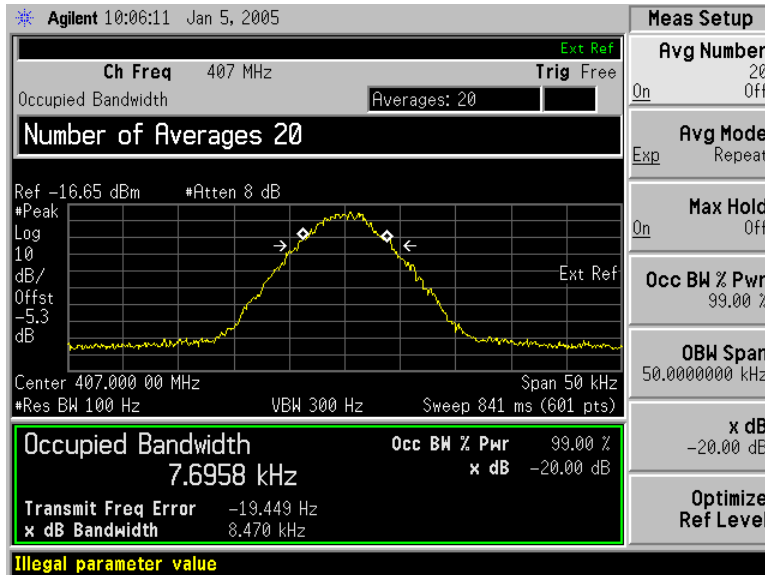

Exciter Output (Amplifier Input)  
407 MHz  
F1E Modulation

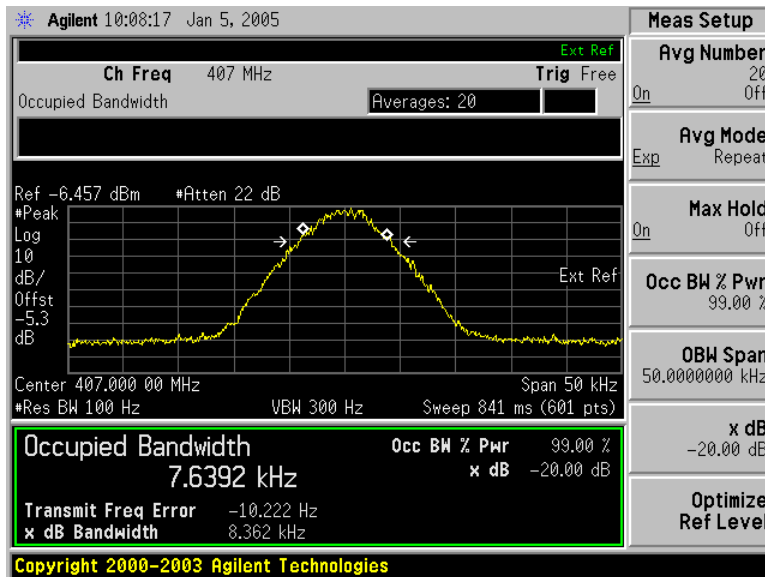

Amplifier Output  
407 MHz  
F1E Modulation Input



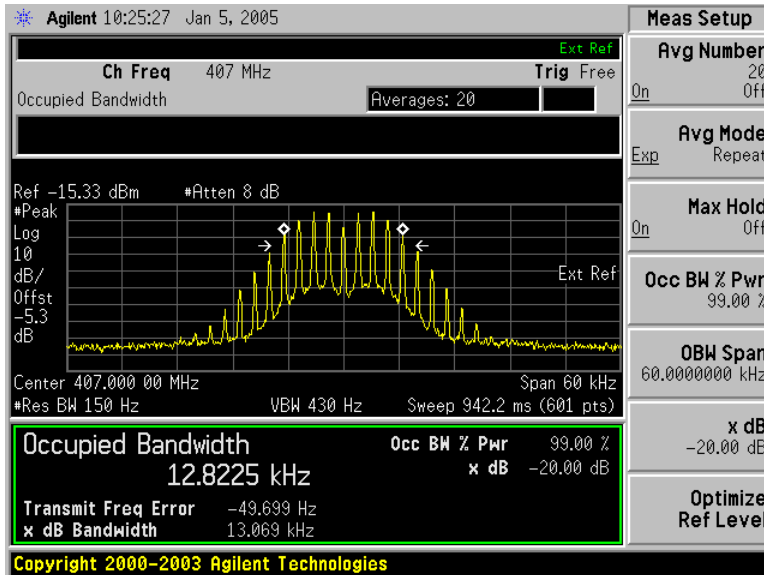

Exciter Output (Amplifier Input)  
407 MHz  
F3D Modulation

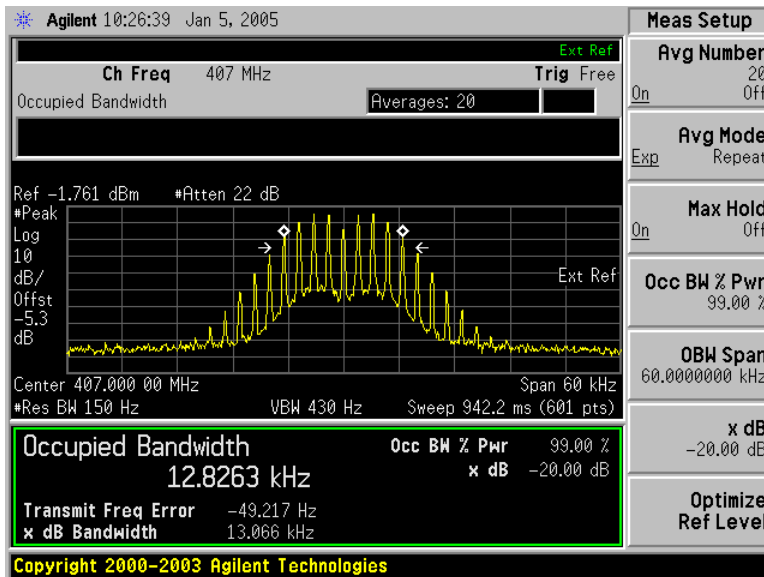

Amplifier Output  
407 MHz  
F3D Modulation Input

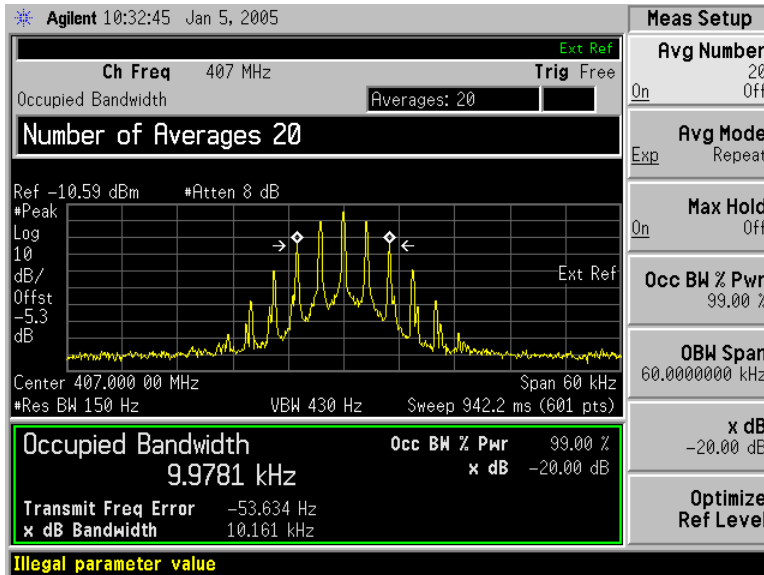

Exciter Output (Amplifier Input)  
407 MHz  
F3E Modulation

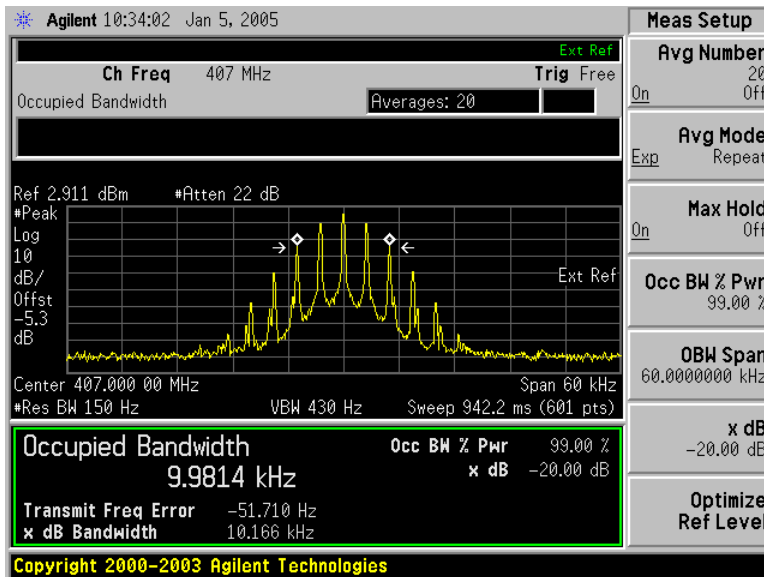

Amplifier Output  
407 MHz  
F3E Modulation Input

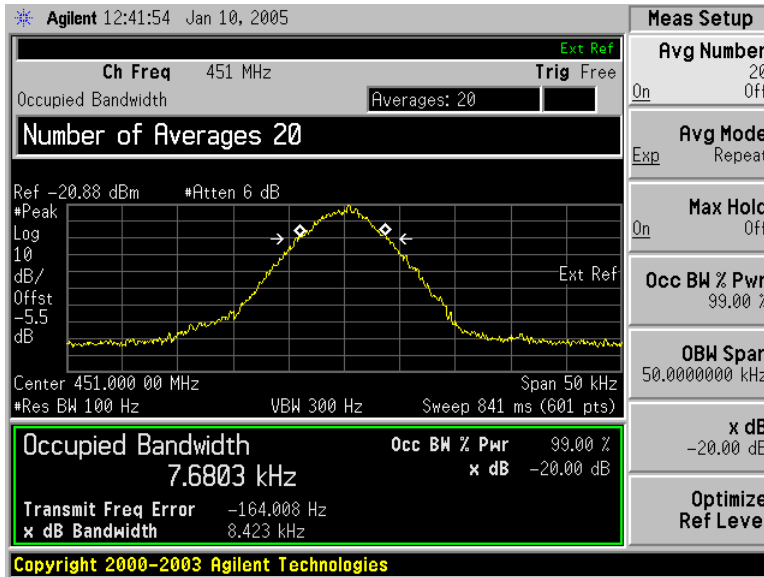

Exciter Output (Amplifier Input)  
451 MHz  
F1D Modulation

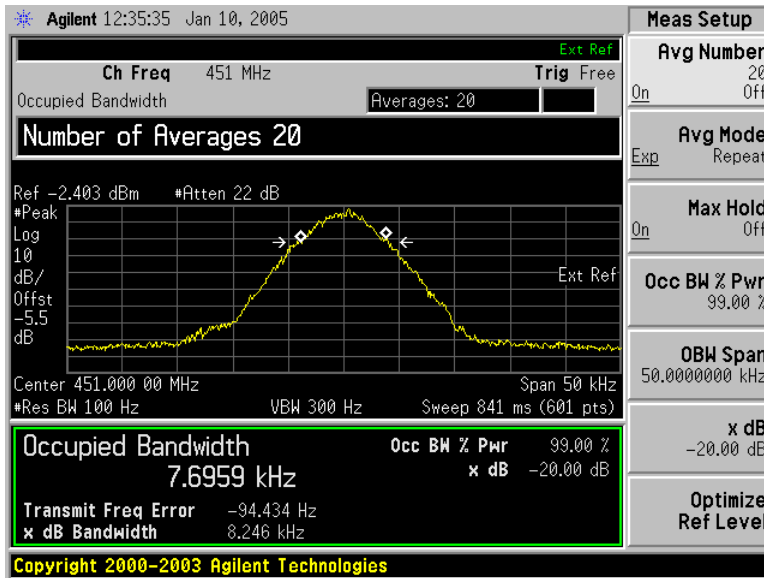

Amplifier Output  
451 MHz  
F1D Modulation Input

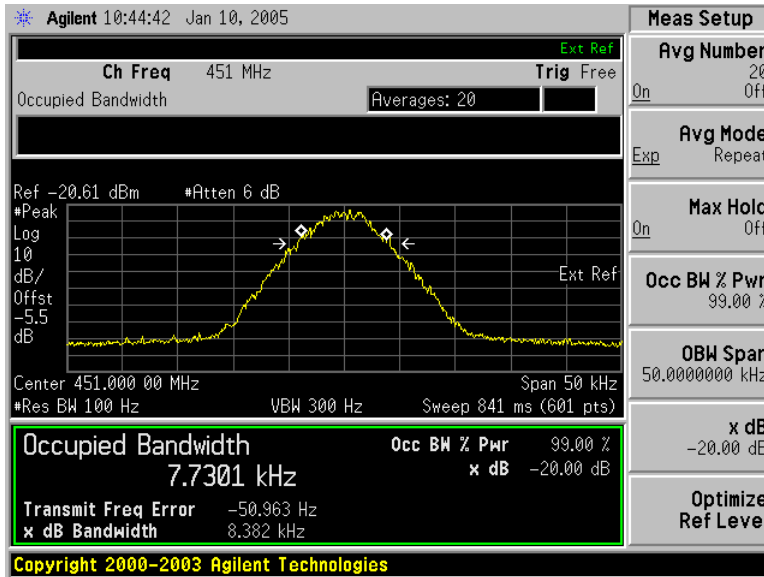

Exciter Output (Amplifier Input)  
451 MHz  
F1E Modulation

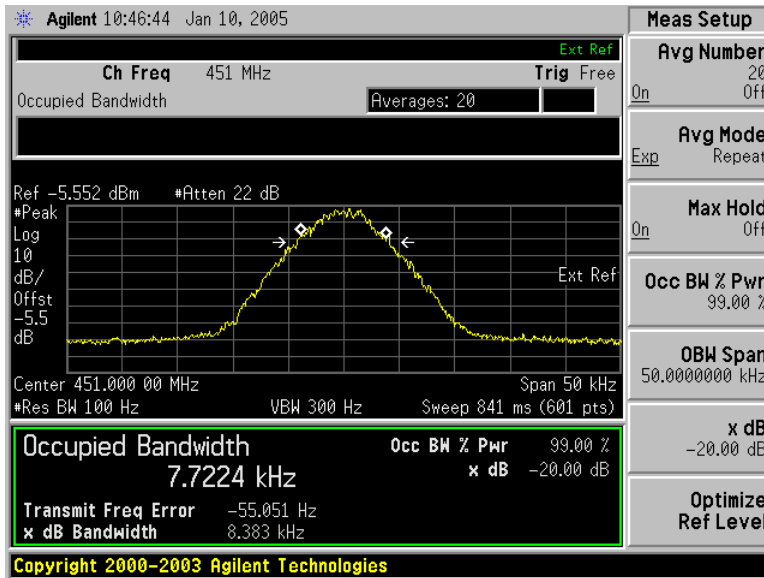

Amplifier Output  
451 MHz  
F1E Modulation Input

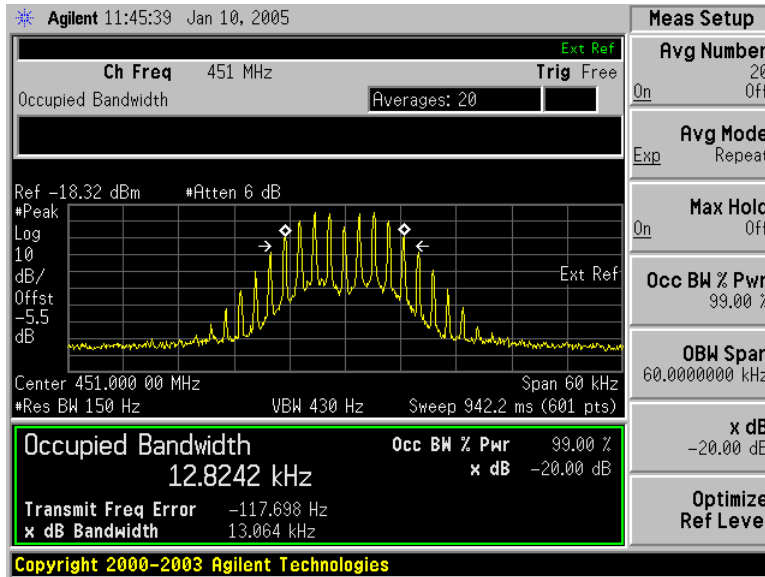

Exciter Output (Amplifier Input)  
451 MHz  
F3D Modulation

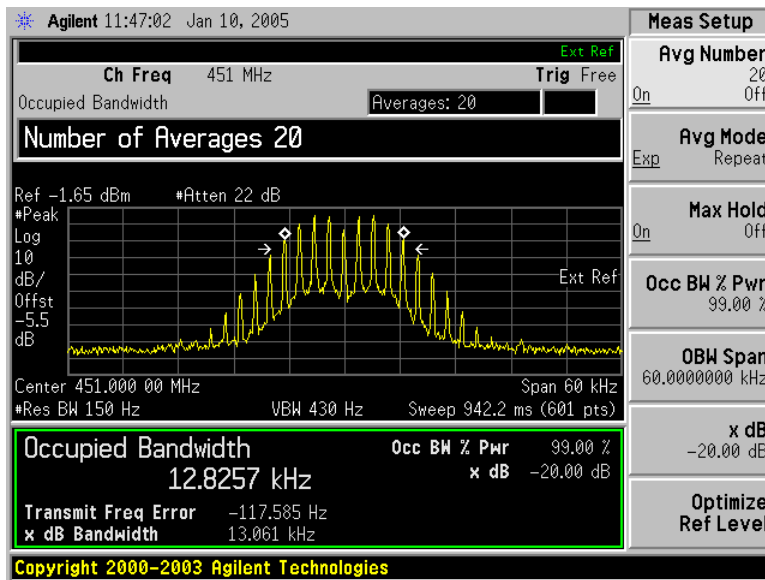

Amplifier Output  
451 MHz  
F3D Modulation Input

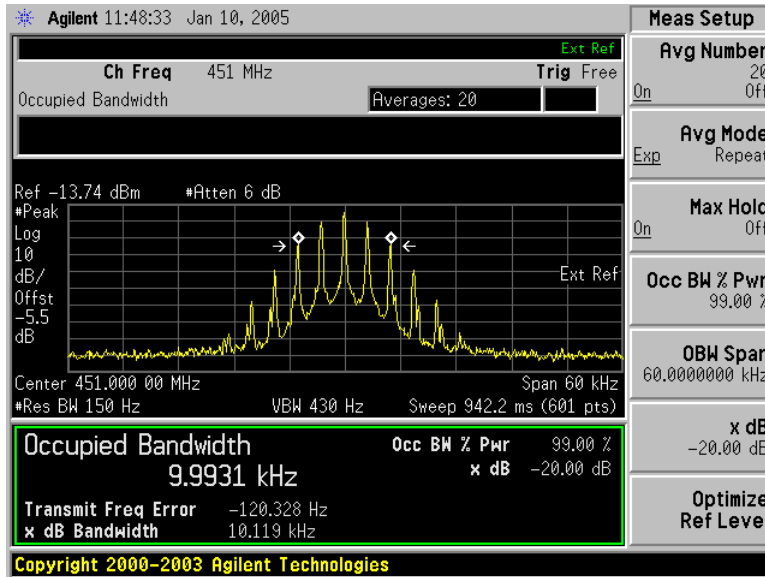

Exciter Output (Amplifier Input)  
451 MHz  
F3E Modulation

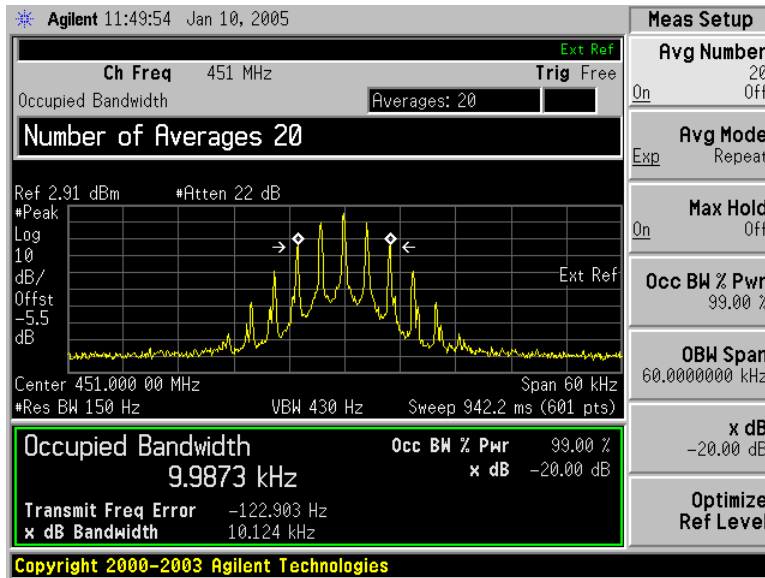

Amplifier Output  
451 MHz  
F3E Modulation Input

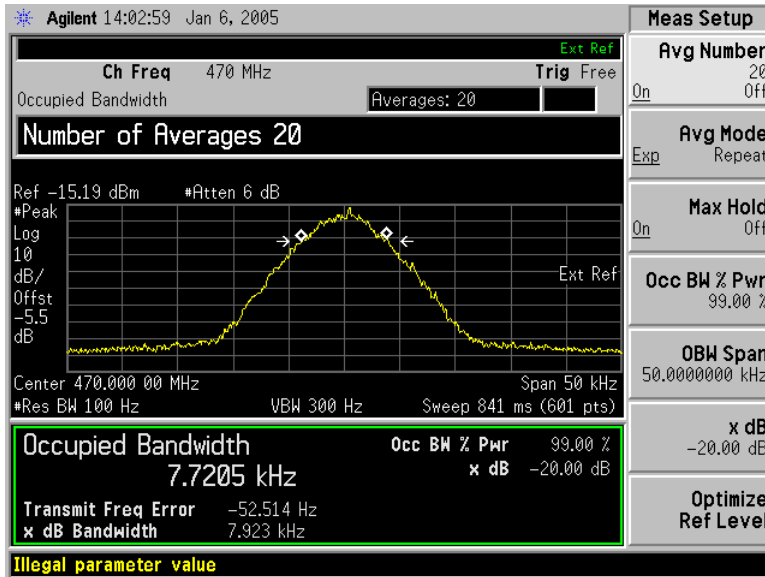

Exciter Output (Amplifier Input)  
470 MHz  
F1D Modulation

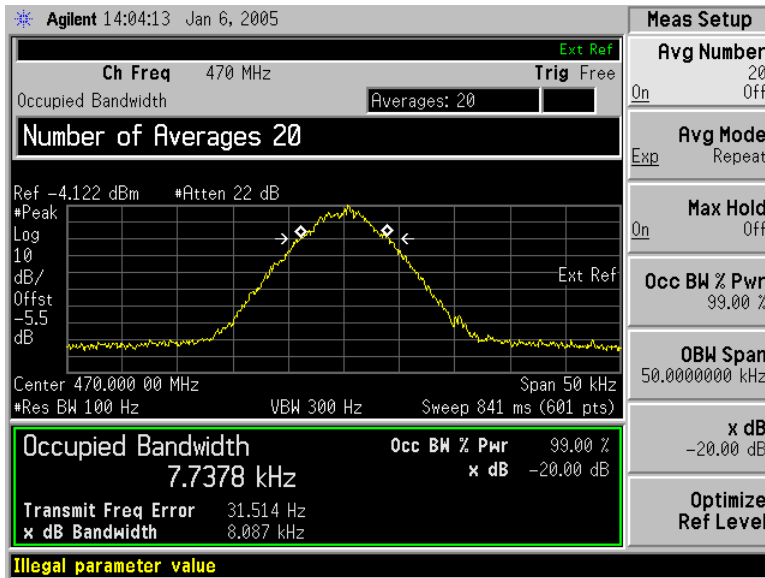

Amplifier Output  
470 MHz  
F1D Modulation Input

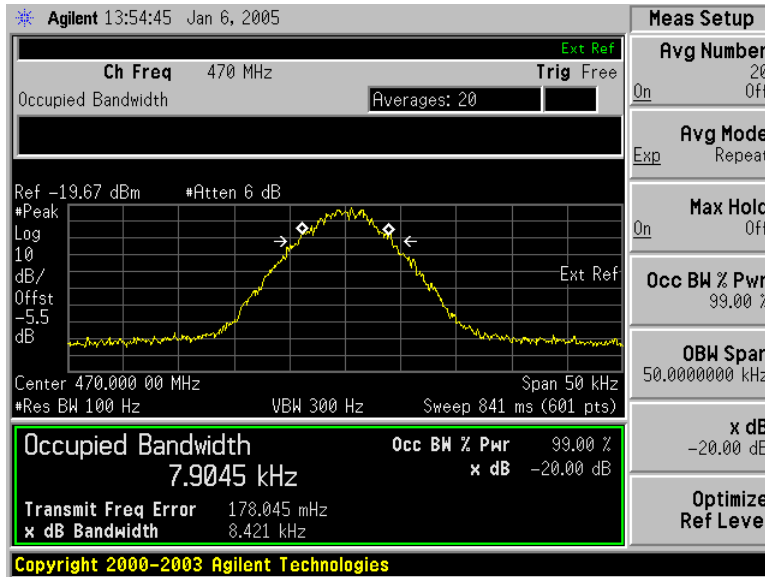

Exciter Output (Amplifier Input)  
470 MHz  
F1E Modulation

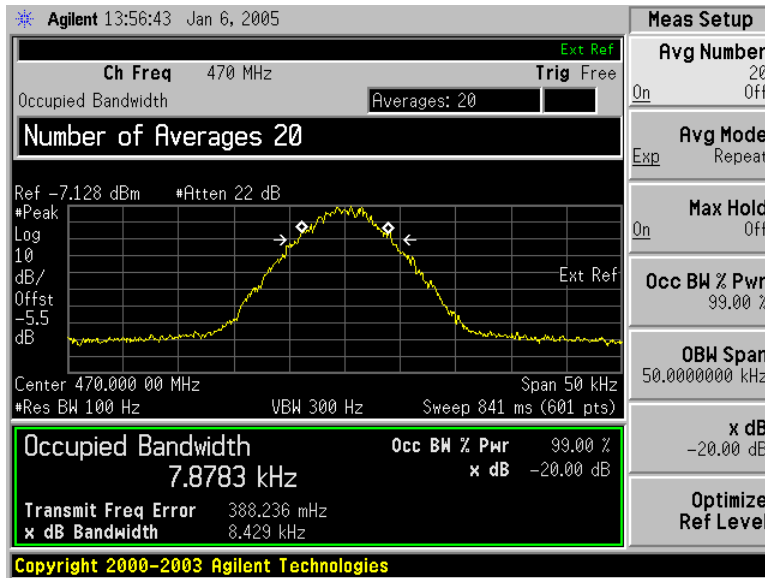

Amplifier Output  
470 MHz  
F1E Modulation Input



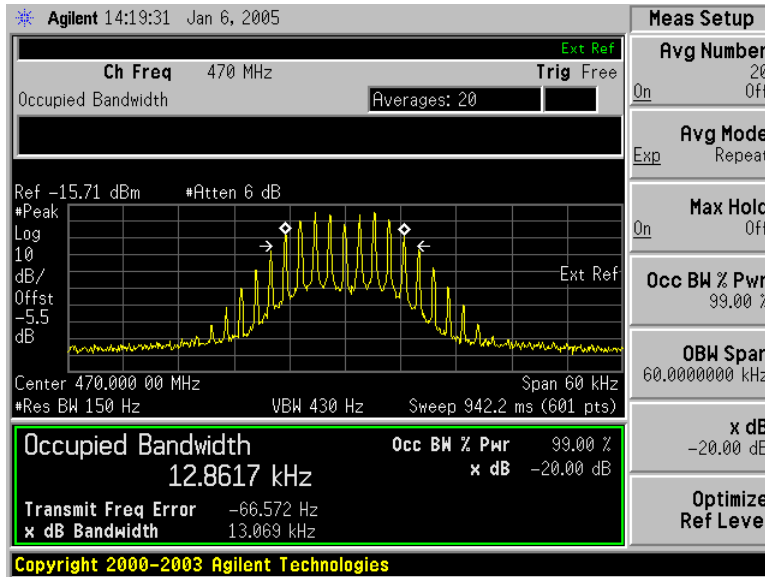

Exciter Output (Amplifier Input)  
470 MHz  
F3D Modulation

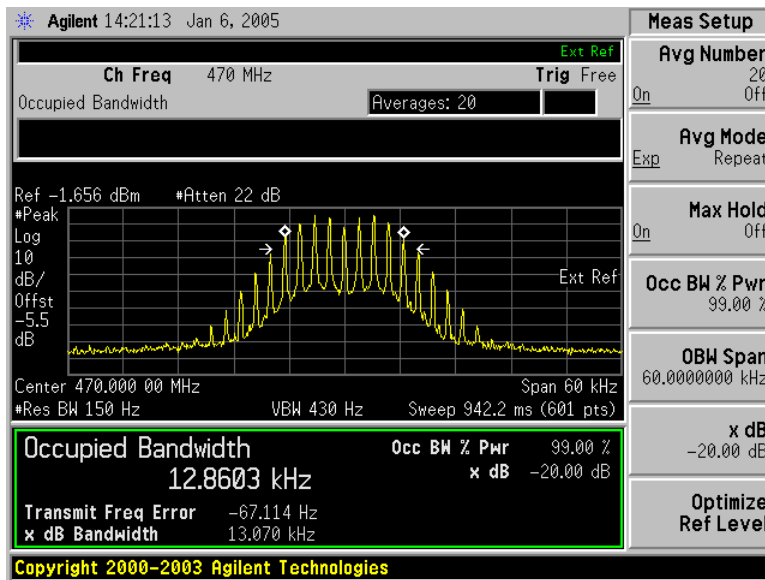

Amplifier Output  
470 MHz  
F3D Modulation Input

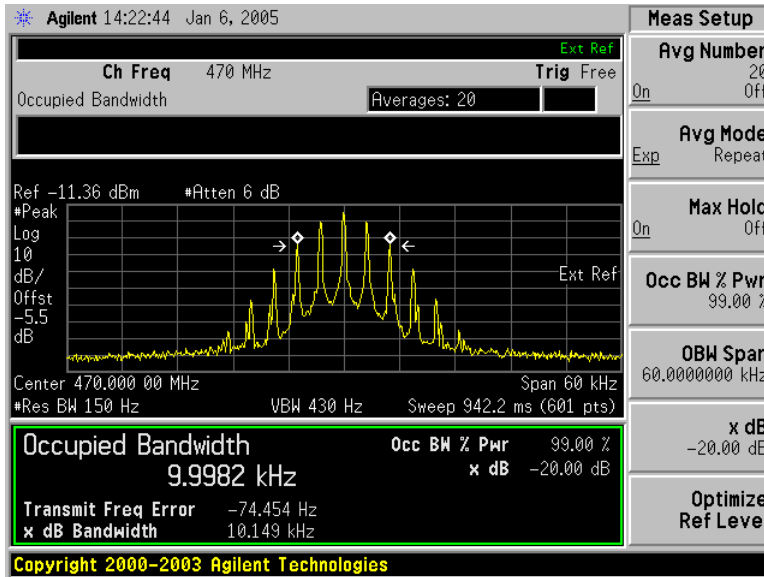

Exciter Output (Amplifier Input)  
470 MHz  
F3E Modulation

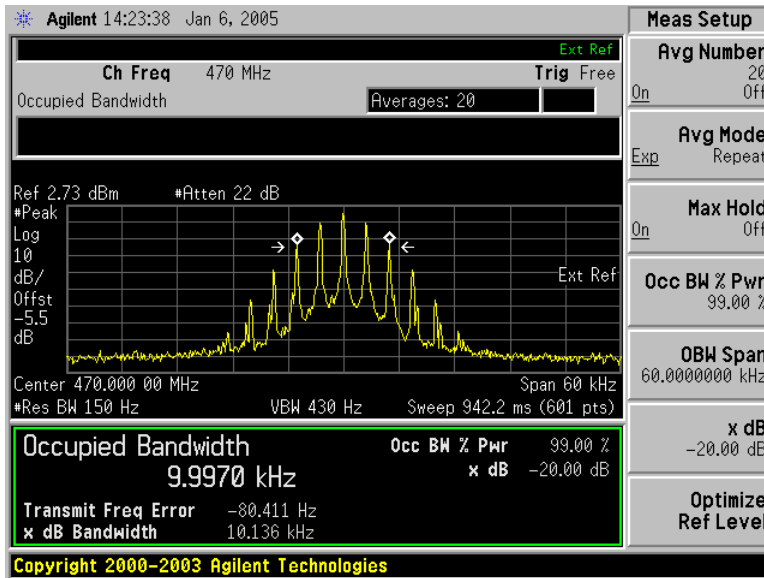

Amplifier Output  
470 MHz  
F3E Modulation Input

**5. Spurious Emissions at Antenna Terminals** (47 CFR §2.1051)

**Minimum Standard:** -13dBm (-57.8dBc at 30W Out)

**Test Results:** Complies

**EUT Model #:** AMP-2/450-30

**Test Data:** See following graphs:

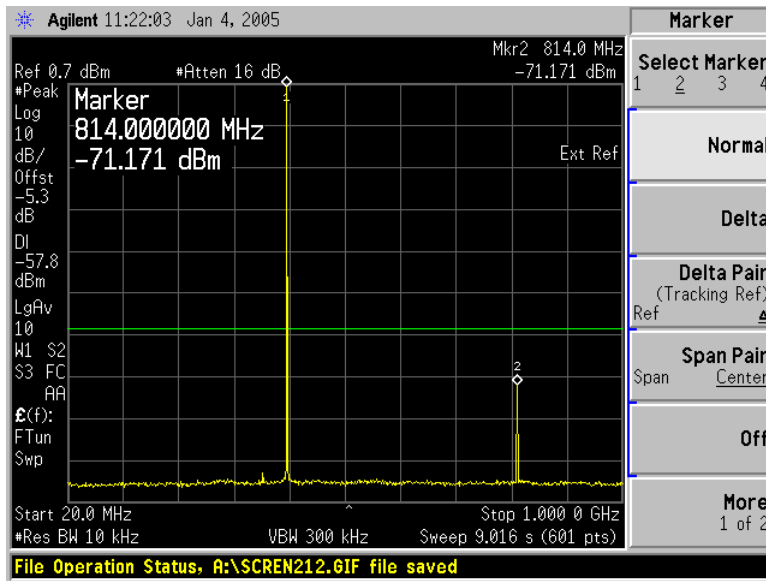

Conducted Spurious  
407 MHz  
20-1000 MHz  
No Notch Filter Inserted  
F1D Modulation Input

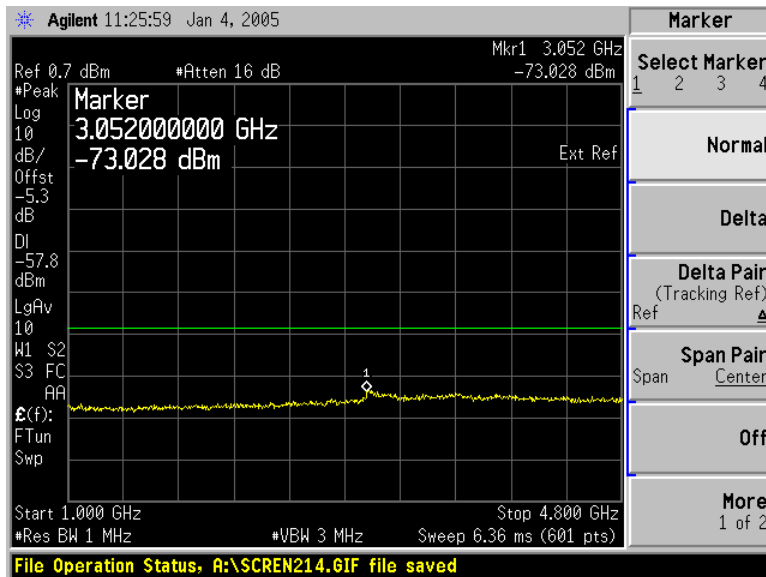

Conducted Spurious  
407 MHz  
1-4.8 GHz  
Notch Filter Inserted  
F1D Modulation Input

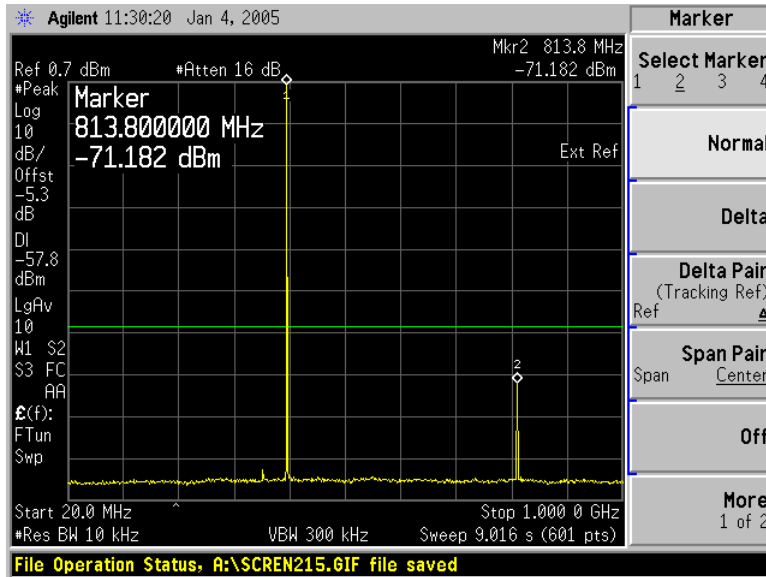

Conducted Spurious  
407 MHz  
20-1000 MHz  
No Notch Filter Inserted  
F1E Modulation Input

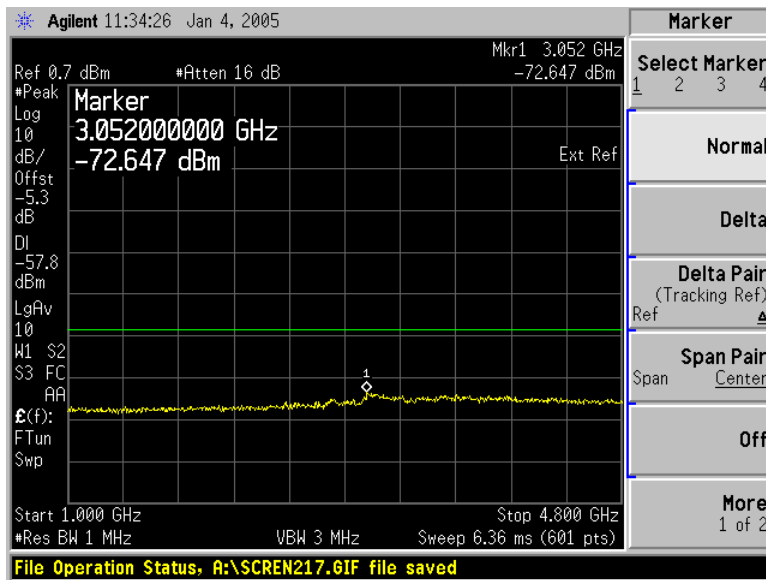

Conducted Spurious  
407 MHz  
1-4.8 GHz  
Notch Filter Inserted  
F1E Modulation Input

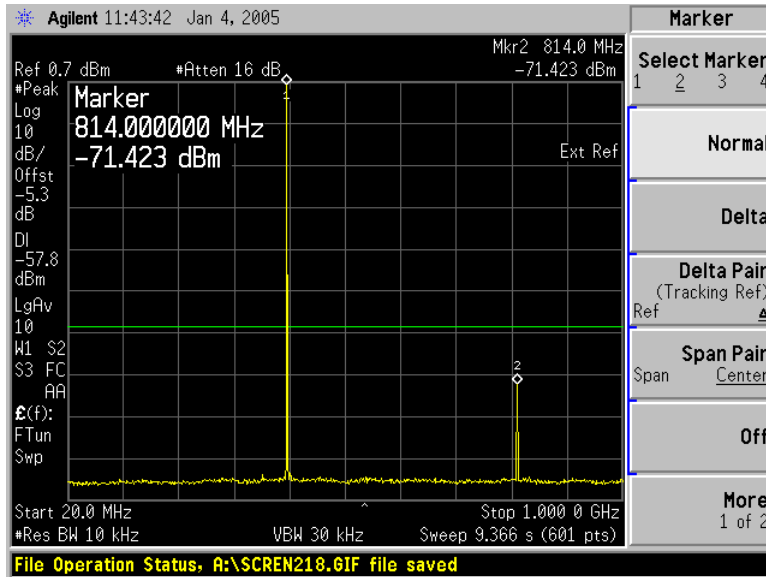

Conducted Spurious  
407 MHz  
20-1000 MHz  
No Notch Filter Inserted  
F3D Modulation Input

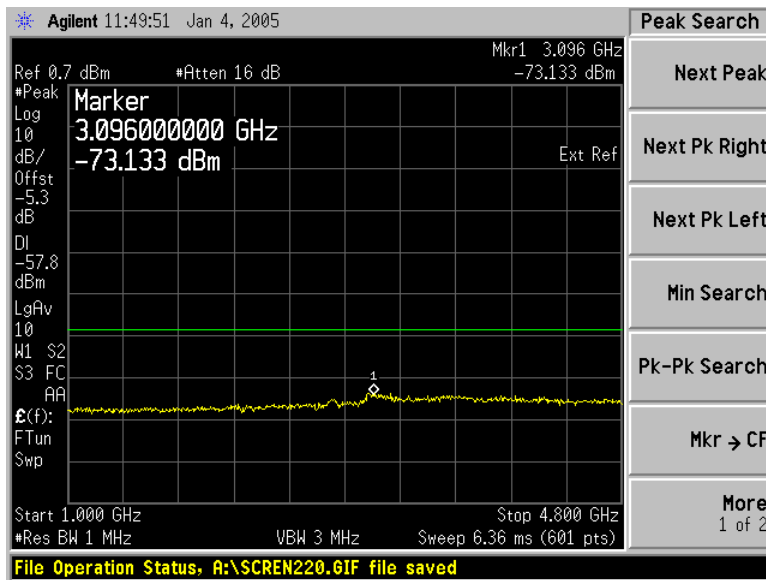

Conducted Spurious  
407 MHz  
1-4.8 GHz  
Notch Filter Inserted  
F3D Modulation Input

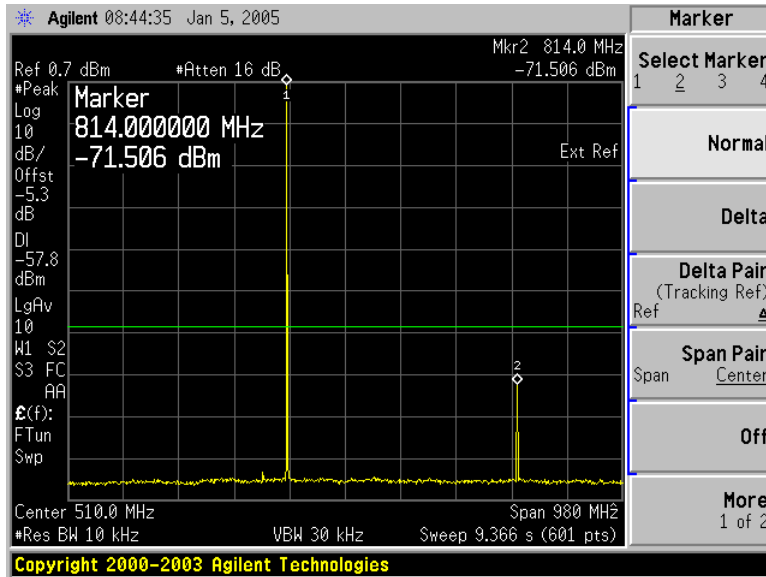

Conducted Spurious  
 407 MHz  
 20-1000 MHz  
 No Notch Filter Inserted  
 F3E Modulation Input

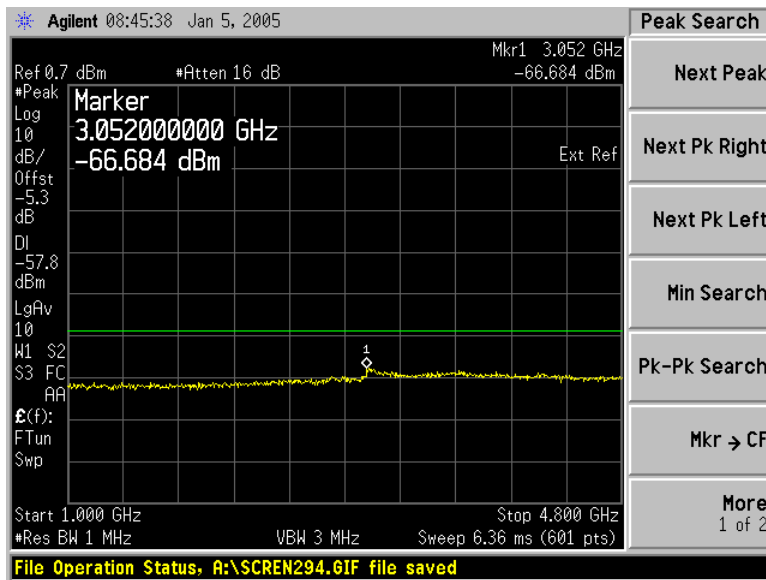

Conducted Spurious  
 407 MHz  
 1-4.8 GHz  
 Notch Filter Inserted  
 F3E Modulation Input

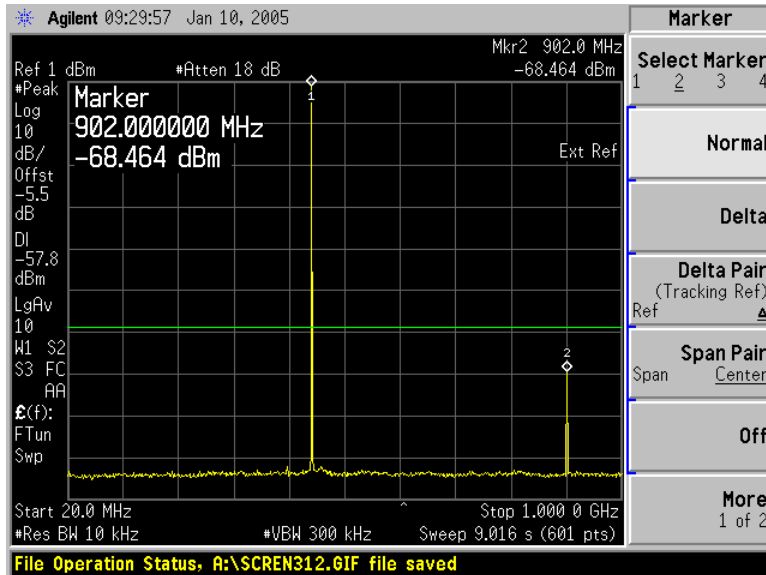

Conducted Spurious  
451 MHz  
20-1000 MHz  
No Notch Filter Inserted  
F1D Modulation Input

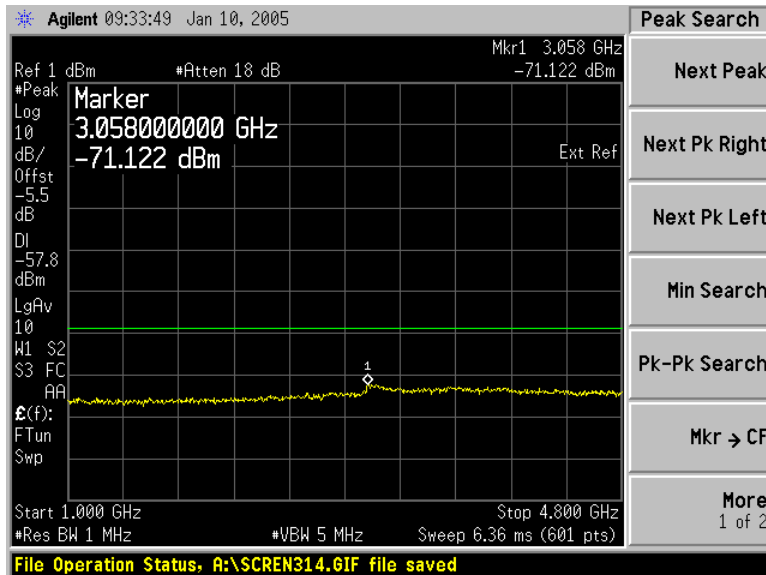

Conducted Spurious  
451 MHz  
1-4.8 GHz  
Notch Filter Inserted  
F1D Modulation Input



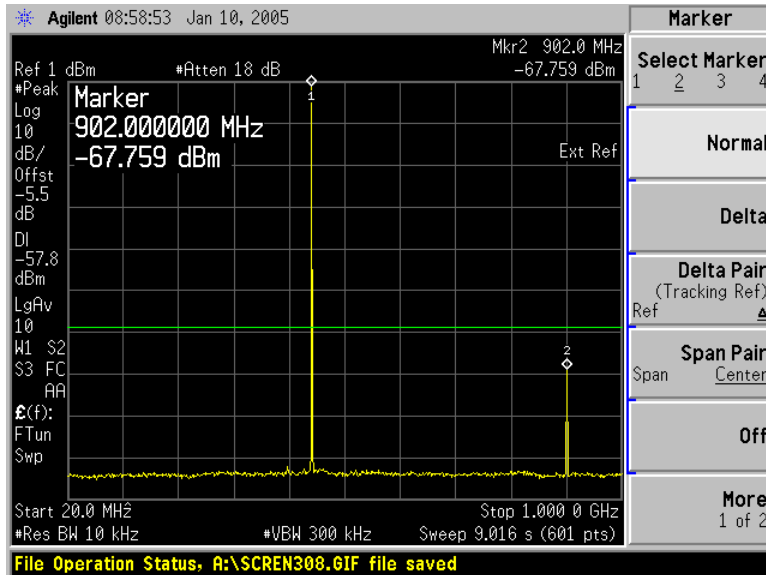

Conducted Spurious  
451 MHz  
20-1000 MHz  
No Notch Filter Inserted  
F1E Modulation Input

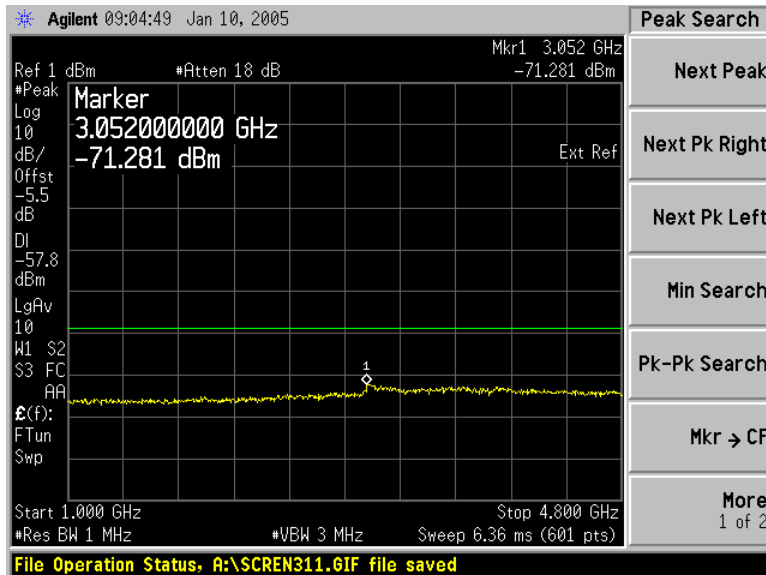

Conducted Spurious  
451 MHz  
1-4.8 GHz  
Notch Filter Inserted  
F1E Modulation Input

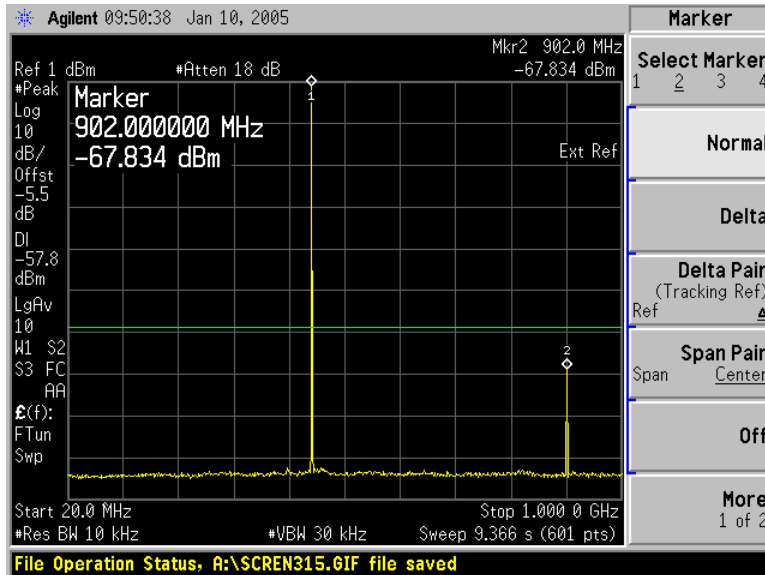

Conducted Spurious  
451 MHz  
20-1000 MHz  
No Notch Filter Inserted  
F3D Modulation Input

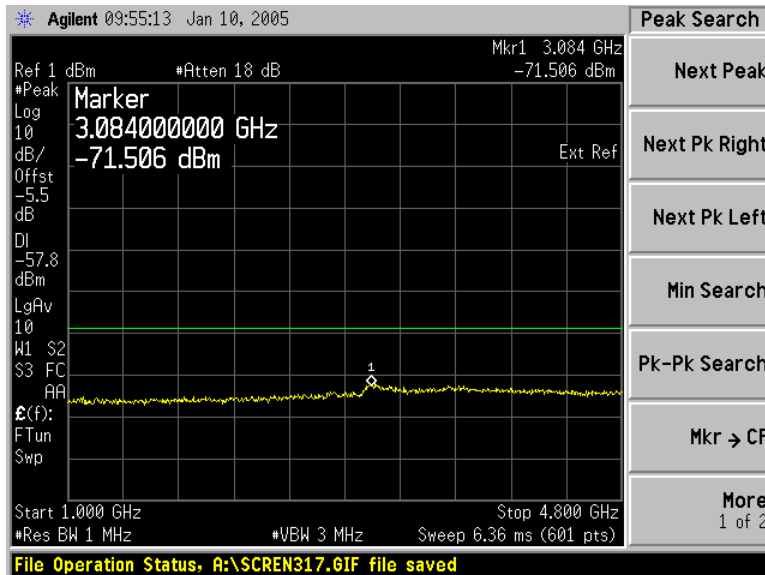

Conducted Spurious  
451 MHz  
1-4.8 GHz  
Notch Filter Inserted  
F3D Modulation Input

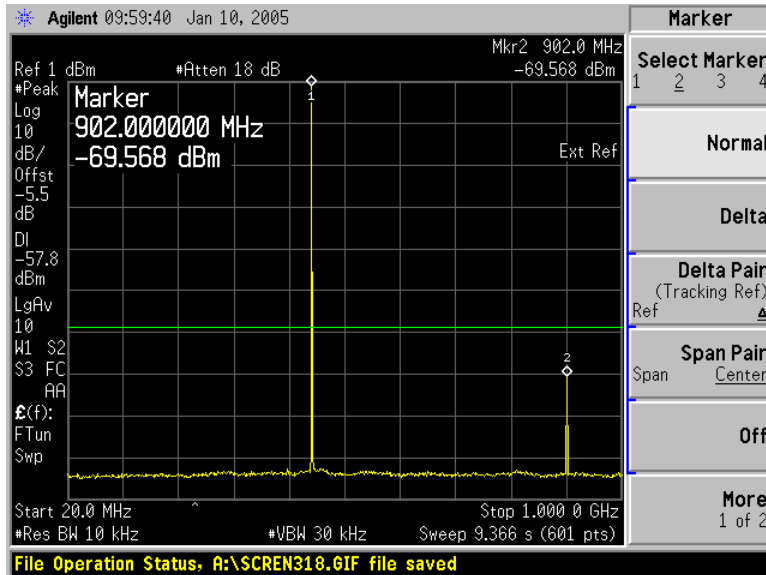

Conducted Spurious  
451 MHz  
20-1000 MHz  
No Notch Filter Inserted  
F3E Modulation Input

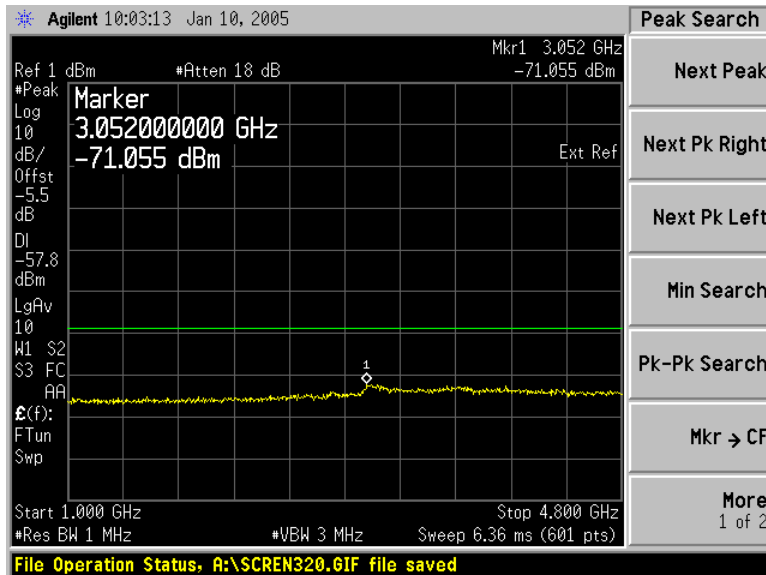

Conducted Spurious  
451 MHz  
1-4.8 GHz  
Notch Filter Inserted  
F3E Modulation Input

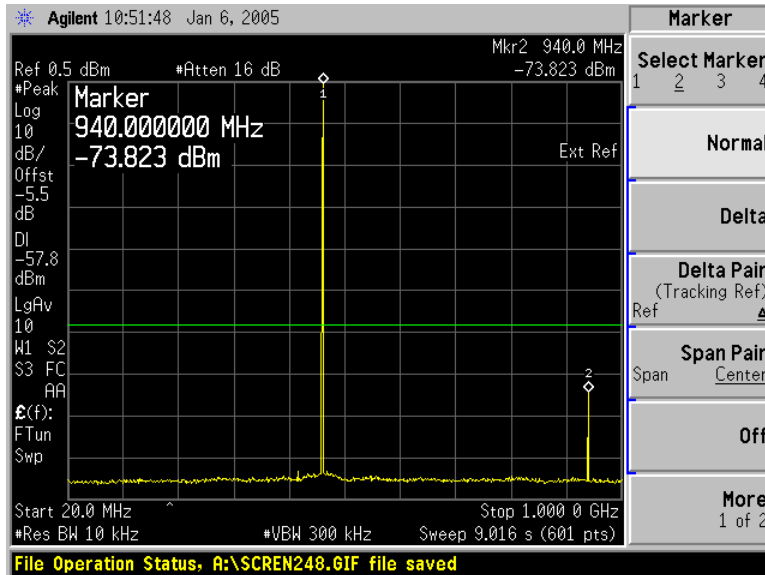

Conducted Spurious  
470 MHz  
20-1000 MHz  
No Notch Filter Inserted  
F1D Modulation Input

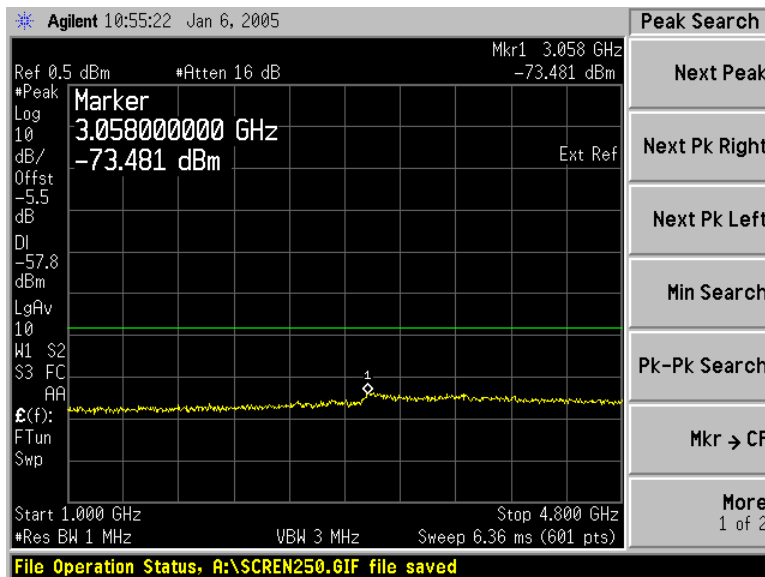

Conducted Spurious  
470 MHz  
1-4.8 GHz  
Notch Filter Inserted  
F1D Modulation Input

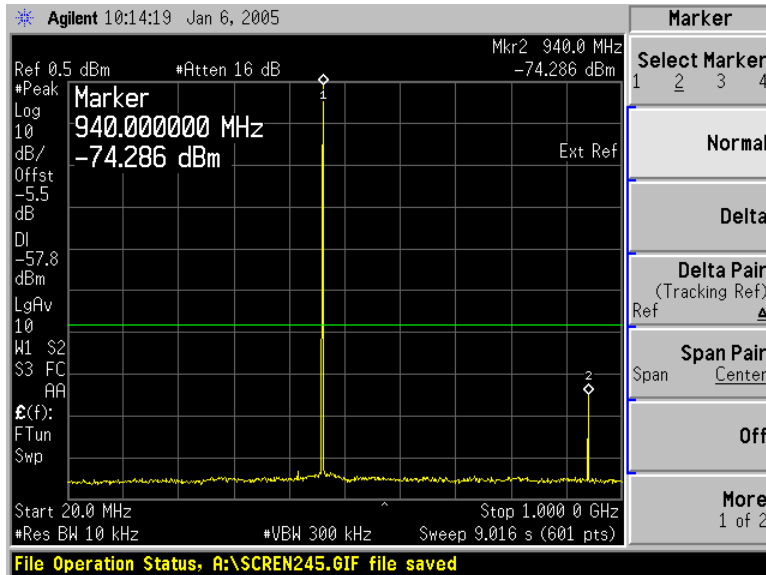

Conducted Spurious  
470 MHz  
20-1000 MHz  
No Notch Filter Inserted  
F1E Modulation Input

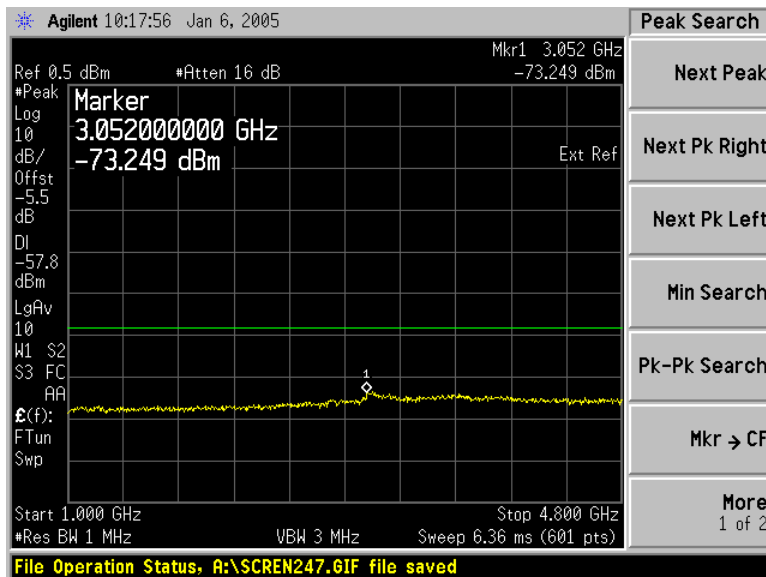

Conducted Spurious  
470 MHz  
1-4.8 GHz  
Notch Filter Inserted  
F1E Modulation Input

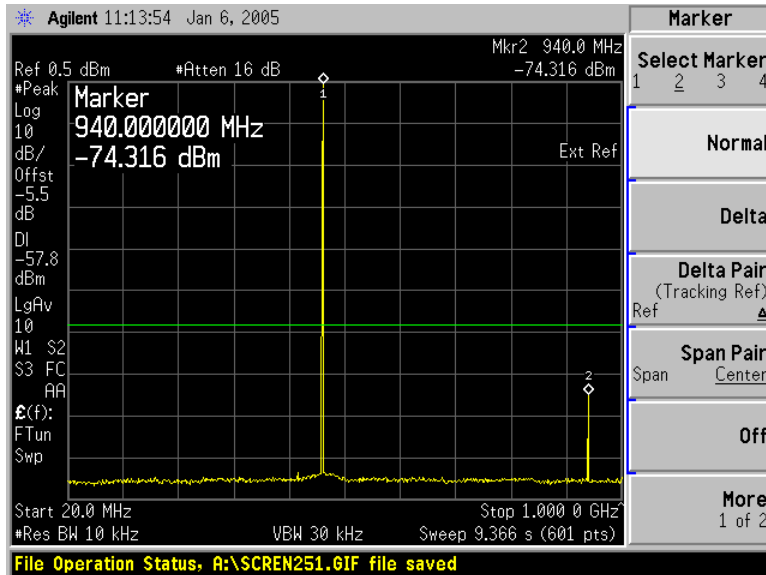

Conducted Spurious  
470 MHz  
20-1000 MHz  
No Notch Filter Inserted  
F3D Modulation Input

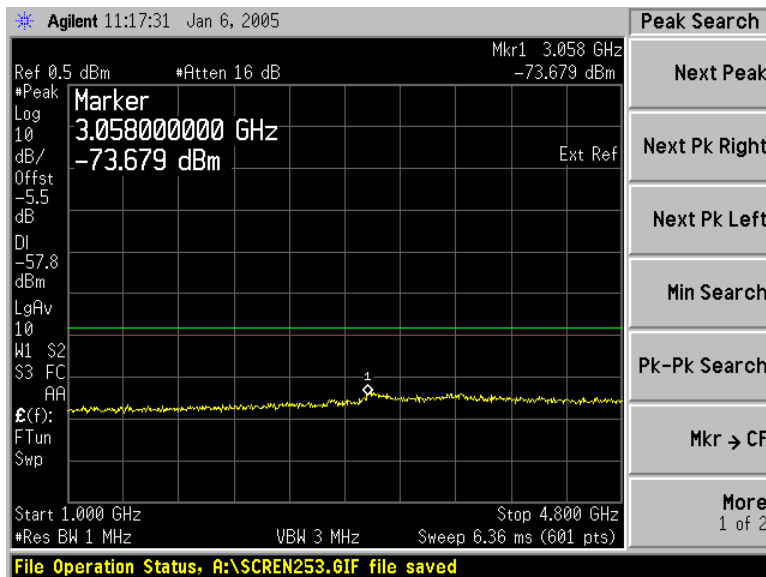

Conducted Spurious  
470 MHz  
1-4.8 GHz  
Notch Filter Inserted  
F3D Modulation Input

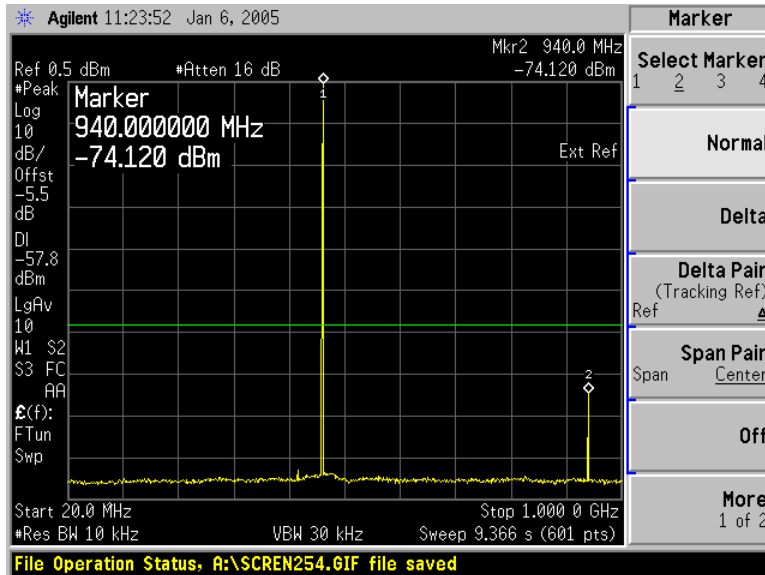

Conducted Spurious  
470 MHz  
20-1000 MHz  
No Notch Filter Inserted  
F3E Modulation Input

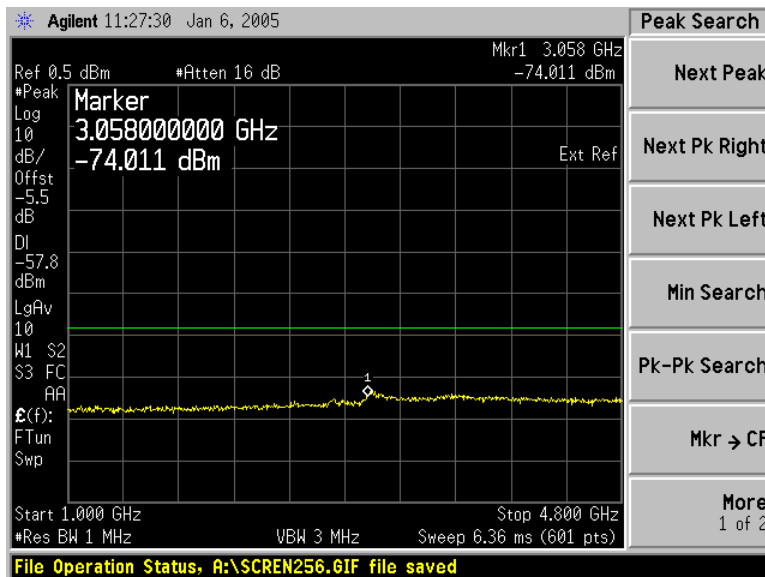

Conducted Spurious  
470 MHz  
1-4.8 GHz  
Notch Filter Inserted  
F3E Modulation Input

**6. Field Strength of Spurious Emissions** (47 CFR §2.1053)

**Minimum Standard:** -20dBm (77.4dB $\mu$ V/m)

**Test Results:** Complies

Note: Radiated Emissions were tested by Acme Testing Co., Acme WA. Test facilities used to perform Radiated and Conducted Emissions Tests are registered with the FCC under Registration Number 90420.

**Test Data:** See attached Appendix A "*H4JVT-30 - Radiated Emissions Report*" for full test results.

**Worst Case Test Results for Each Model:**

Model	Frequency (MHz)	Effective Radiated Power (dBm)	Margin (dB)
AMP-2/450-30	407	-22.8	-2.8
AMP-2/450-30	451		
AMP-2/450-30	470		



## 7. Block Diagrams

- **RF Output Power**
- **Occupied Bandwidth**
- **Spurious Emissions at Antenna Terminals**

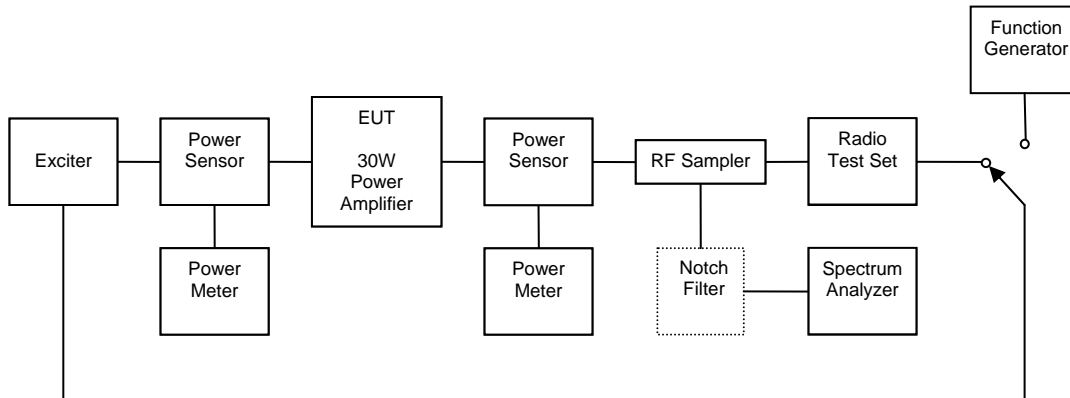

## 8. Test Equipment List

CAL CYCLE	EQUIPMENT	MANUFACTURER	MODEL	SERIAL	LAST CAL	NEXT CAL
N/A	Exciter	Daniels Electronics Ltd	UT-4D420	10080	N/A	N/A
N/A	Exciter	Daniels Electronics Ltd	UT-4D460	10016	N/A	N/A
N/A	Exciter	Daniels Electronics Ltd	UT-4D460	R&D 10010	N/A	N/A
N/A	RF Power Meter	Bird	4421	4937	N/A	N/A
1 Year	Directional Power Sensor	Bird	4022	11258	26/Jan/2005	15/Jan/2006
N/A	RF Power Meter	Bird	4421	5420	N/A	N/A
1 Year	Directional Power Sensor	Bird	4022	12490	29/Sep/2004	12/Oct/2005
N/A	Variable RF Sampler	Bird	4275	N/A	N/A	N/A
1 Year	Radio Test Set	Marconi Instruments	2965A	133052/010	12/Apr/2004	12/Apr/2005
1 Year	Spectrum Analyzer	Agilent Technologies	E4440A	US40420232	8/Apr/2004	22/Apr/2005
N/A	Function Generator*	Good Well Instrument	GFG-8019G	4690527	N/A	N/A
N/A	Notch Filter	Daniels Electronics Ltd	N/A	N/A	N/A	N/A

\* The frequency and output specifications of this device were verified using the calibrated 2965A Marconi Radio Test Set, listed above.