



Manufacturer

TLV. CO., LTD.

Kakogawa, Japan

is approved by LRQA LTD. to ISO 9001/14001

TLV®

Instruction Manual

Gas Leak Detection System

SonicMan™

Ultrasonic Leak Detector

SonicMan: SO2(-EX)

Introduction

Thank you for purchasing the **TLV** gas leak detection system, the **SonicMan System**.

This product has been thoroughly inspected before being shipped from the factory. When the product is delivered, before doing anything else, check the specifications and external appearance to make sure nothing is out of the ordinary.

The **SonicMan System** is made up of the following 3 components:

Ultrasonic Leak Detector	SonicMan	: SO2(-EX)
PDA(Personal Digital Assistants) Software	SonicLogger	: SO-DL
Inspection Data Management Software	SonicManager	: SO-PC

This instruction manual is intended for use with the Ultrasonic Leak Detector - the **SonicMan: SO2(-EX)**. For instructions on the use of the **SonicLogger: SO-DL** and the **SonicManager: SO-PC**, please see their respective instruction manuals.

Instruction manuals for the optional PDA (hardware), headphone and other components are also included. The safety precautions listed in these manuals must be followed to ensure safe and correct use of the product, to prevent personal injury to yourself and others and to prevent damage to property. To ensure safe and correct use of this product, be sure to observe the safety precautions listed in this manual as they relate to installation, operation, maintenance and repair of the product. Furthermore, **TLV** accepts no responsibility for any damage or accidents occurring as a result of failure to observe these safety precautions.

Be sure to read these instruction manuals carefully before use and follow the instructions to be sure of using the product properly. Additionally, as these manuals are necessary not only for initial software setup but also for subsequent troubleshooting, please keep them in a safe place for future reference.

This product has undergone strict quality management and product inspection before being shipped from the factory. However, in the event of malfunction or defects, please contact your local **TLV** representative or the **TLV** customer service center.

TLV accepts no responsibility for incorrect use of the product by the customer or any third-party, malfunction occurring during use, other defects and any damaged caused by this product, excluding cases in which it is under obligation to pay reparations by law.

This instruction manual and product are subject to modifications without notice, for the purpose of improvement.

Unauthorized reprinting or reproduction, in whole or in part, of this instruction manual or this product's hardware or software is strictly prohibited.

<p>This device complies with part 15 of the FCC Rules. Operation is subject to the following two conditions: (1)This device may not cause harmful interference, and (2)this device must accept any interference received, including interference that may cause undesired operation.</p>
--

Contents

Introduction	2
Contents	3
1 SonicMan Standard Set.....	4
2 Observe These Precautions to Ensure Safety.....	5
1. SO2(-EX) Precautions.....	6
2. Battery Pack Precautions.....	7
3. Charger Precautions	9
4. SO2-EX Precautions.....	10
3 SonicMan 's Principle of Detection	11
4 The Procedure for Gas Leak Diagnosis	12
5 SonicMan Components and Features	13
6 Before Using the SonicMan	14
1. Charging the Battery Pack	14
2. Inserting and Removing the Battery Pack	14
7 Let's Try It Out!.....	15
1. Turning the Power ON and OFF	15
2. Attaching the Headphone (In Quiet Areas).....	15
3. How to Read the Screen	15
4. Increasing and Decreasing the Sensitivity.....	16
5. Using the Automatic Sensitivity Adjustment	16
6. Turning the Laser Pointer ON and OFF	16
7. Estimating Leakage Amount	17
8. Saving the Inspection Data in the Internal Memory	19
9. Recalling Saved Data.....	21
10. Deleting Saved Data	21
11. Operation Flow Chart.....	22
8 Optional Settings and Adjustments	23
1. Display of Remaining Battery Time	23
2. Turning ON and OFF the Backlight	23
3. Setting Leakage Amount Calculation to "Automatic"	23
4. Setting the Automatic Volume Control.....	23
5. Setting the Automatic Power OFF Time Delay	24
6. Adjusting the Headphone Output Volume	24
7. Setting the Date & Time.....	24
8. Setting Data Communication Way.	25
9 How to Use the Accessories.....	26
10 Troubleshooting.....	27
11 Specifications	29
12 Product Warranty	31

1 **SonicMan** Standard Set

1. **SO2(-EX)**
2. Nozzle
3. Holster
4. Headphone
5. Battery Pack
6. Communications Cable for the PC
7. Battery Charger (Including AC adapter)
8. Storage Case



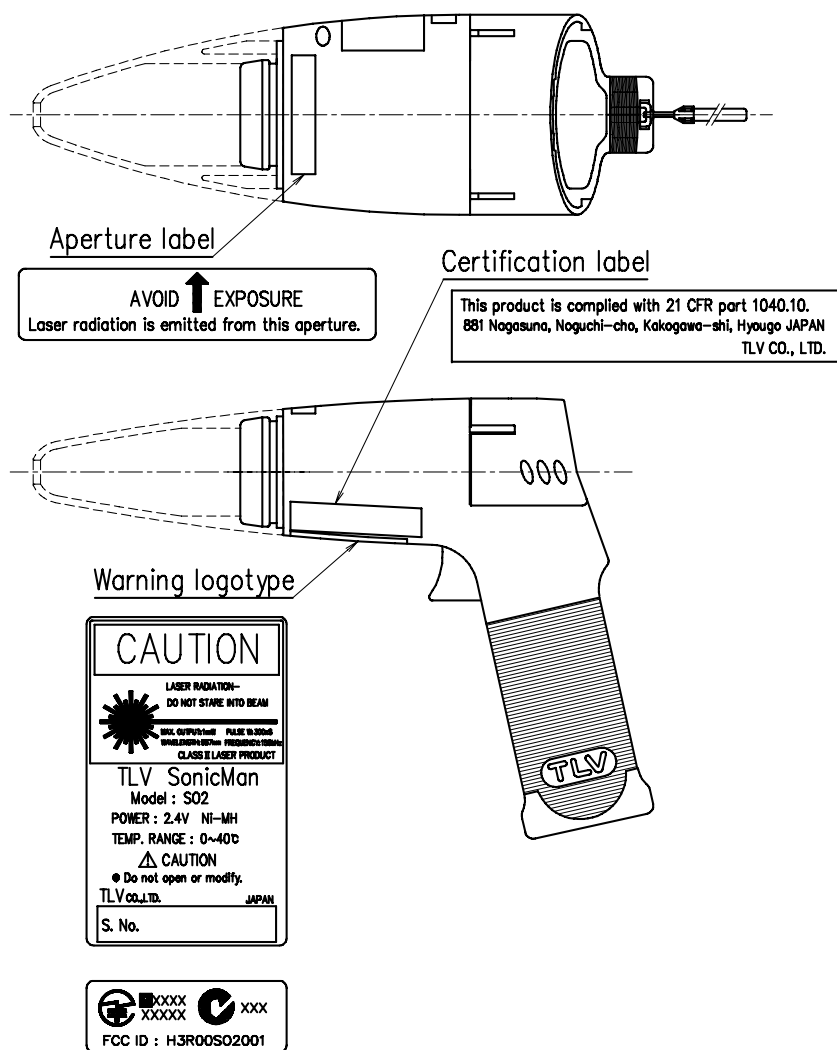

<Position of Label>







2 Observe These Precautions to Ensure Safety

- Read this “Observe These Precautions to Ensure Safety” section carefully before use and be sure to follow the instructions.
- Installation, inspection, maintenance, repairs, disassembly, adjustment and valve opening/closing should be carried out only by trained maintenance personnel.
- The precautions listed in this manual are designed to ensure safety and to prevent equipment damage and personal injury. For situations that may occur as a result of erroneous handling, three different types of cautionary items are used to indicate the degree of urgency and the scale of potential damage and danger: **DANGER**, **WARNING** and **CAUTION**.
- The three types of cautionary items above are very important for safety: be sure to observe all of them as they relate to installation, use, maintenance and repair. Furthermore, **TLV** accepts no responsibility for any accidents or damage occurring as a result of failure to observe these precautions.

Symbols











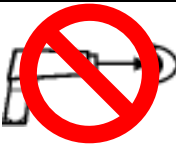

	Indicates a DANGER, WARNING or CAUTION item.
 DANGER	Indicates an urgent situation which poses a threat of death or serious injury
 WARNING	Indicates that there is a potential threat of death or serious injury
 CAUTION	Indicates that there is a possibility of injury or equipment / product damage

The meanings of the various categories of precautionary symbols are as follows:





 PROHIBITED	This precautionary symbol indicates an item or action that must not be used or performed	 NO MOISTURE	This precautionary symbol indicates an item that must not be allowed to become wet
 DISASSEMBLY PROHIBITED	This precautionary symbol indicates an item that must not be disassembled	 NO WET HANDS	This precautionary symbol indicates an action or item that must not be performed or touched with wet hands
 MANDATORY	This precautionary symbol indicates an action or precaution that MUST be performed or observed		

Observe These Precautions to Ensure Safety











1. **SO₂(-EX) Precautions**

 DANGER			
Do not use any components other than those included. Use the included battery pack, charger and communications cable. Use of other items could result in excessive heat generation, ignition, rupture, electrical shock, fire or other undesirable situations.	 MANDATORY	Take measures to prevent entanglement. Operating the unit with the strap, headphone cord or communications cable hanging loosely could result in accidents caused by their becoming caught in rotating equipment. Hold them close to the body and take measures to prevent entanglement during operation.	 MANDATORY
Do not direct the beam of the laser pointer at people. If the beam of the laser pointer shines into eyes, it may result in deterioration or loss of vision. When not in use, turn the laser pointer OFF.	 PROHIBITED	SO₂ (Standard type) is not explosion proof type. Do not use SO₂ in hazardous locations. Failure to observe this precaution could result in injury, electrical shock, ignition or fire. Please check the specification of SO₂-EX whether it can be used in areas requiring explosion-proof equipment.	 PROHIBITED
 WARNING			
Do not disassemble or modify. Failure to observe this precaution could result in injury, electrical shock, ignition or fire.	 PROHIBITED	Do not operate the buttons or stare at the screen while walking. Failure to observe these precautions could lead to accidents such as tripping or collisions.	 PROHIBITED
Be attentive to the background noises in the surrounding area. When wearing the headphone, it becomes difficult to hear noises from the surrounding area. Operate the unit together with a person who is not wearing any headphone or take measures during operation to ensure advance awareness of potential dangers in the surrounding area.	 MANDATORY	Do not place components in microwave ovens or high-pressure vessels, and do not place components in the vicinity of electromagnetic devices. Such handling could result in excessive heat generation, smoke, damage to circuitry, battery fluid leakage, rupture or ignition.	 PROHIBITED
Do not subject the unit to strong impact and do not throw it. Such handling could result in leakage of the battery fluid, excessive heat generation, rupture, ignition or injury.	 PROHIBITED	Do not turn the power ON while wearing the headphone. A sudden loud sound may be emitted, leading to hearing impairment or injury. After turning the power ON, check to see whether a loud sound is being output before putting on the headphone.	 PROHIBITED
This equipment has been tested and found to comply with the limits for a Class A digital device, pursuant to part 15 of the FCC Rules. These limits are designed to provide reasonable protection against harmful interference when the equipment is operated in a commercial equipment. This equipment generates, uses, and can radiate radio frequency energy and, if not installed and used in accordance with the instruction manual, may cause harmful interference to radio communications. Operation of this equipment in a residential area is likely to cause harmful interference in which case the user will be required to correct the interference at his own expense.			 PROHIBITED

Observe These Precautions to Ensure Safety



 CAUTION			
Make sure no foreign matter gets inside the unit. In areas with a great deal of metal powder or other fine foreign matter, take measure to prevent this foreign matter from getting inside the unit. The presence of such foreign matter could result in fire or unit failure.	 PROHIBITED	Do not let the unit become wet. If liquid gets inside the unit, it may result in excessive heat generation, electrical shock or unit failure. Be careful of the location of use and the method of handling.	 NO MOISTURE
Changes or modifications not expressly approved by the party responsible for compliance could void the user's authority to operate the equipment.	 PROHIBITED		

2. Battery Pack Precautions



 DANGER			
Do not use any charger other than the charger provided with the unit. Failure to observe this precaution could result in leakage of the battery fluid, excessive heat generation, rupture or ignition.	 PROHIBITED	Do not disassemble, modify, solder, etc. Failure to observe this precaution could result in leakage of the battery fluid, excessive heat generation, rupture or ignition.	 DISASSEMBLY PROHIBITED
If fluid leaks from the battery and gets in the eyes, flush it out. Do not rub the eyes, and after immediately flushing out thoroughly with clean water, see a doctor.	 MANDATORY	Refrain from touching the terminals to other metal items, to avoid causing a short in the battery pack. Failure to observe this precaution could result in leakage of the battery fluid, excessive heat generation, rupture or ignition. When transporting the battery pack, carry it in the soft case, etc.	 PROHIBITED
Do not cause the unit to become wet by immersing in water, salt water or liquid chemicals. Failure to observe this precaution could result in leakage of the battery fluid, excessive heat generation, rupture or ignition.	 PROHIBITED	Do not apply heat to the unit or throw it into a fire. Failure to observe this precaution could result in leakage of the battery fluid, excessive heat generation, rupture or ignition.	 PROHIBITED
Do not leave unit where it will be exposed to direct sunlight or in areas that will become very hot, such as interiors of cars, near heating equipment, etc. Failure to observe this precaution could result in leakage of the battery fluid, excessive heat generation, rupture or ignition.			 PROHIBITED
Do not forcibly insert the battery pack. The battery pack must be inserted into the SonicMan and the charger with the proper orientation. Forcible insertion could result in fluid leakage, excessive heat generation, rupture or ignition.	 PROHIBITED	Do not use the battery pack in devices other than the SonicMan unit. Failure to observe this precaution could result in battery pack failure, rupture or fire.	 PROHIBITED

 Observe These Precautions to Ensure Safety

 **WARNING**









<p>Cease use of the battery pack immediately if the unit exhibits abnormal operation. If during battery pack use, charging or storage, irregularities such as fluid leakage, an unusual smell, unusual heat generation, discoloration or deformation are noticed, cease use of the unit immediately. If use is continued under such conditions, excessive heat generation, ignition or rupture may result.</p>		
<p>If full charging does not occur even after the prescribed charging time has been exceeded, stop charging. If use is continued under such conditions, battery fluid leakage, excessive heat generation, ignition or rupture may result.</p>		<p>If battery fluid leaks and comes into contact with the body, rinse it off immediately. There is danger of resultant damage to the skin. Immediately rinse any battery fluid off with clean water.</p>
	MANDATORY	MANDATORY





 **CAUTION**

<p>When not intending to use for extended periods of time, remove the battery pack from the unit and store in a dry, cool, dark location. Failure to observe this precaution could result in fluid leakage, rust, deterioration in performance or a reduction in service life.</p>		<p>Charge the battery pack within the temperature range of 5° C to 35° C (. If charged at a temperature outside of this range, fluid leakage, abnormal heat generation, ignition or rupture may result. Additionally, deterioration in performance or a reduction in service life may result.</p>	
<p>Do not dispose of the battery pack with normal garbage. The SonicMan battery pack is recyclable. If at any time, whether before or after use, the battery pack becomes unnecessary, observe your company regulations and, after insulating the contact terminals by covering them with tape, return the battery pack to a TLV office.</p>			
			PROHIBITED

 Observe These Precautions to Ensure Safety





3. Charger Precautions

 WARNING			
<p>Use only with the specified voltage. Failure to observe this precaution could result in smoke, ignition, rupture or fire from the charger or battery pack.</p>	 MANDATORY	<p>Do not disassemble or modify. Failure to observe this precaution could result in excessive heat generation, ignition, electrical shock or injury.</p>	 DISASSEMBLY PROHIBITED
<p>Refrain from touching the charger terminals to other metal items, to avoid causing a short in the unit. Failure to observe this precaution could result excessive heat generation, ignition or electrical shock.</p>	 PROHIBITED	<p>Do not operate the unit with wet hands. Failure to observe this precaution could result in electrical shock.</p>	 NO WET HANDS
<p>Do not use the unit in humid areas or in areas in which it could become wet from water or liquid chemicals. Failure to observe this precaution could result in electrical shock, excessive heat generation or ignition.</p>	 NO MOISTURE	<p>Do not charge a battery pack other than the SonicMan battery pack. Failure to observe this precaution could result in excessive heat generation, ignition, rupture or fire.</p>	 PROHIBITED
<p>Do not charge in areas that have a great deal of dust or metal powder. The presence of dust or metal powder could result in excessive heat generation or fire.</p>			 PROHIBITED

 CAUTION			
<p>Do not touch the electrode contacts. Failure to observe this precaution could result in electrical shock, deformation or injury.</p>	 PROHIBITED	<p>Do not cause the electrical cord to have sharp bends, place heavy items on top of it or cut it. Failure to observe this precaution could result in failure of the electrical cord, electrical shock, excessive heat generation or fire.</p>	 PROHIBITED
<p>Cease use immediately if the unit exhibits abnormal operation. If the unit does not charge, there is smoke, unusual heat generation or an unusual smell, immediately pull the power plug out of the outlet. If use is continued under such conditions, fire or electrical shock may result.</p>			 MANDATORY

Observe These Precautions to Ensure Safety

4. SO2-EX Precautions

 WARNING	
<p>Use SO2-EX only in areas requiring explosion-proof that suits an explosion-proof specification of SO2-EX. The explosion-proof specification of SO2-EX is CE0081 II1G EEx ia IIC T4 Hazardous locations: Zone 0, 1 & 2 Protection method: Intrinsically safe "ia" Gas group: IIC Temperature code: T4(135 C) at max ambient temperature 40 C</p>	 MANDATORY
<p>Do not use SO2-EX out of operating ambient temperature range in areas requiring explosion-proof equipment. The operating ambient temperature of SO2-EX is 0 to 40 degree C.</p>	 PROHIBITED
<p>Do not use standard type battery pack (Model SO1-101) for SO2-EX in areas requiring explosion-proof equipment. Only specified battery pack (Model SO2-101EX) can be used for SO2-EX in areas requiring explosion-proof equipment.</p>	 PROHIBITED

3 **SonicMan's** Principle of Detection

1. Leak locations generate a warning sound by their very nature. There are many cases in the field where large amounts of fluid are leaking from the screwed or flanged areas of piping joints or from gaskets.

An ultrasonic signal is generated at these types of leak locations. ("Ultrasonic" is used here to refer to sounds in high frequency bands that cannot be heard by the human ear.)

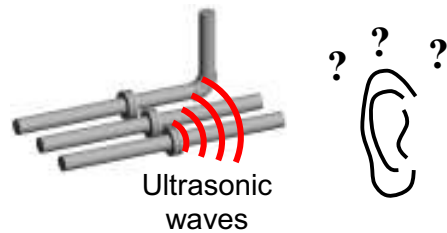

This ultrasonic signal is generated even in the case of very small leaks, and offers a much higher chance of leak location detection than does relying on the spectrum of sound that is audible to the human ear.

2. **SonicMan**, which detects ultrasonic signals and converts them to audible sound, employs an ultrasonic microphone and an electrical band path filter to isolate and detect ultrasonic signals. Furthermore, the ultrasonic signals that have been detected and converted to audible sound can then be heard through the headphone.

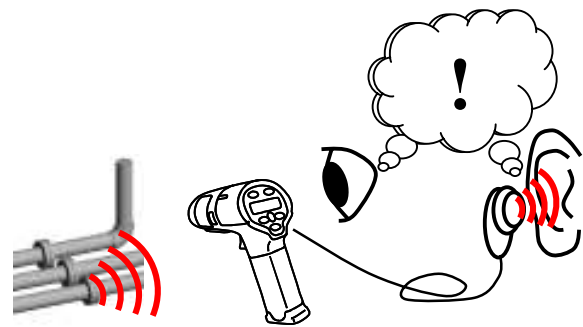

Additionally, concentrating the directional ability of the ultrasonic microphone facilitates the identification of leak locations, and the added use of the laser pointer effects a great increase in the efficiency of leak detection and location identification.

3. Automatic Calculation of Estimated Leakage Amounts

When the reading's distance and relevant information about the object being tested have been input, **SonicMan** displays an automatic calculation of the estimated leakage amount, based on the reading gained during detection. This can be used as a rough measure of the total quantity of losses.

The calculation of leakage amount is made possible by using information, stored in **SonicMan**, that has been gained from previous laboratory experiments.

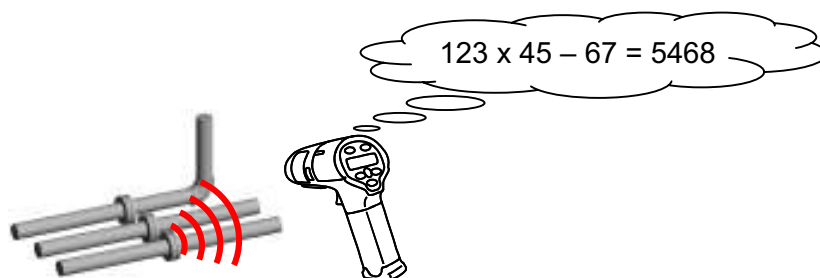

4 The Procedure for Gas Leak Diagnosis

1. Before Going into the Field

Step 1: See the SonicManager instruction

Using **SonicManager**, create the names for management items and a master data file, and then download it to **SonicLogger**.

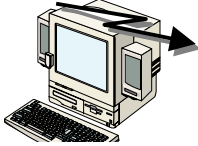

Step 2: See the SonicLogger instruction

Using **SonicLogger**, take photographs of plant and piping layout drawings (maps) for the plant that is to be surveyed for gas leaks.



2. Operation in the Field

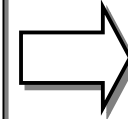

Step 3: See p. 16 ~ p.24 of this instruction manual.

Using **SonicMan**, search for leak locations.

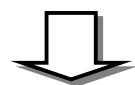

Step 4: See p. 22 of this instruction manual.

Transfer the data from the **SonicMan** to **SonicLogger**.



Step 6: See the SonicLogger instruction manual

Attach a marker to the leak area, and photograph the location using **SonicLogger**.

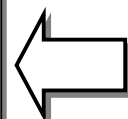

Step 5: See the SonicLogger

Input the location, object being surveyed and piping layout map information into **SonicLogger**.



3. After Returning to the Office

Step 7: See the SonicManager instruction

Upload the saved data from **SonicLogger** to **SonicManager**.

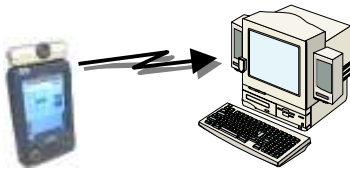

Step 8: See the SonicManager instruction

Print out reports using **SonicManager**.



5 **SonicMan** Components and Features

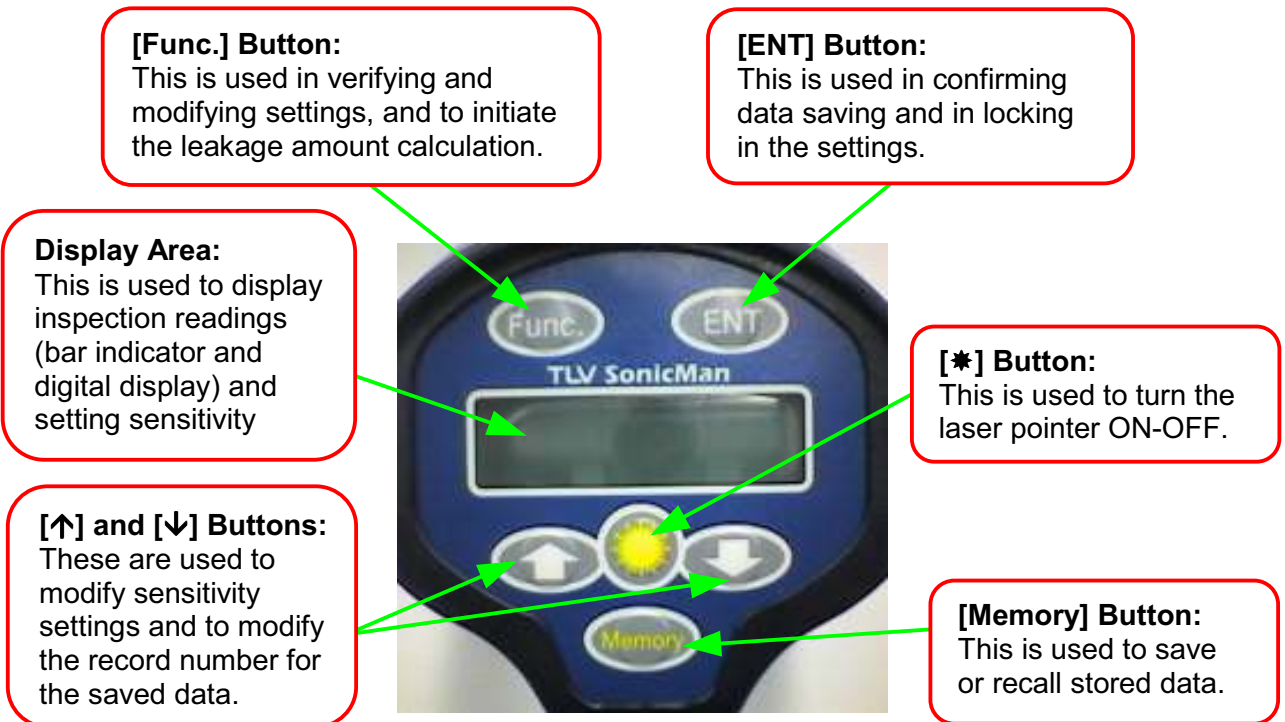
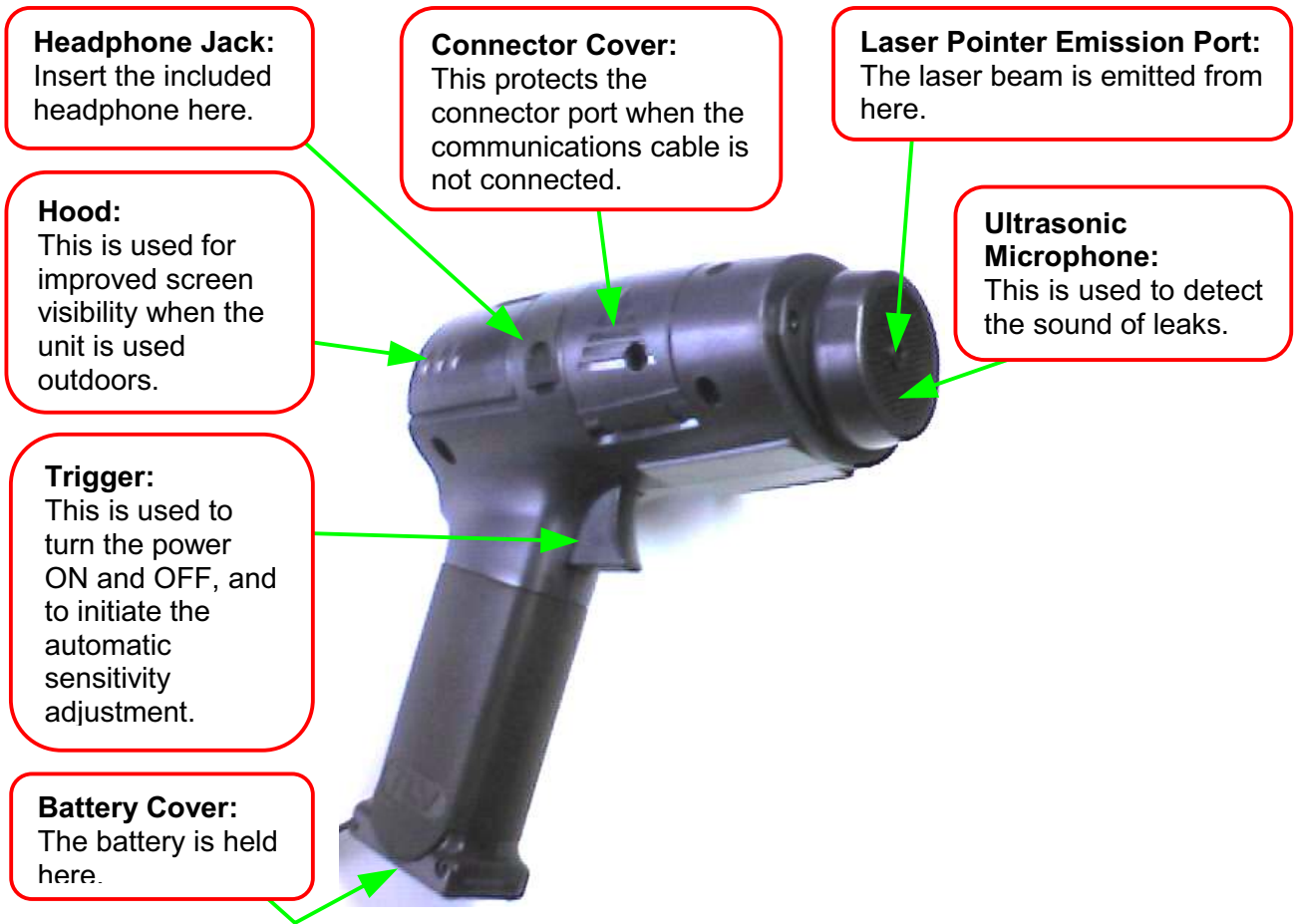

6 Before Using the **SonicMan**



WARNING

Do not charge in a hazardous location.

1. Charging the Battery Pack

- 1) Connect the power cord for the included charger ①.
- 2) Insert the battery pack securely into the charger ②.
- 3) The red “charging” indicator light comes on and the charger automatically begins charging ③.



- 4) Pushing the white button causes the battery pack to be discharged (green light) before charging. Charging (red light) begins automatically after discharging is completed.
- 5) To stop the discharging process (green light) before it is completed, press the white button again. Discharging ceases (the green discharge light goes out), and charging (red light) automatically begins.
- 6) When charging is fully completed, the red “charging” indicator light begins blinking.

2. Inserting and Removing the Battery Pack



WARNING

Battery pack must be changed in a nonhazardous location only.

- 1) Slide back the latch ① and open the **SonicMan** battery cover ②.
- 2) Insert the battery pack with the end on which the contacts are located going in first ③.
- 3) Close the battery cover ④ and slide the latch to fasten the cover in place ⑤.
- 4) When the battery pack is inserted, the power on the **SonicMan** may automatically turn ON. If this occurs, double-click the trigger to turn the power OFF.
- 5) Remove the battery pack by following the above steps, except remove the battery pack in step 2 instead of inserting it.



7 Let's Try It Out!

1. Turning the Power ON and OFF

- 1) Pulling (clicking) the trigger once turns the power ON.
- 2) After turning the power ON, you may immediately begin to search for leaks. It is not necessary to pull the trigger again.
- 3) Pulling the trigger twice in a less than 1-second interval (double-clicking) turns the power OFF.
- 4) However, the power can only be turned OFF when it is in detection mode. The power cannot be turned OFF if it is in setting-modification mode, data recall mode, etc.



2. Attaching the Headphone (In Quiet Areas)

- 1) Insert a battery into the battery case of the headphone. (For full details, see the headphone instruction manual.)
- 2) Lift up the cover for the **SonicMan** headphone jack ①.
- 3) Insert the headphone plug into the **SonicMan** headphone jack ②.
- 4) Attach the headphone battery storage case to a breast pocket, etc. during operation.
- 5) Turn the headphone power switch to ON.
- 6) The headphone with the "R" is for the right ear and the one with the "L" is for the left ear.



3. How to Read the Screen

The reading is displayed by a bar indicator. The bar length (number of squares shown) indicates level presently being detected.

This marks the maximum level reached during leak detection. If the sensitivity setting is modified, this reading is deleted.

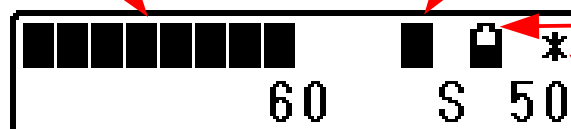

This icon displays battery voltage in 4 levels.

This displays the current sensitivity setting as a quantitative value.

This displays the reading as a quantitative value.

This is displayed when the laser pointer output is ON.

4. Increasing and Decreasing the Sensitivity

To increase the audibility of the sound of a small leak, or in the opposite case, to decrease it when the sound of a leak is too loud, adjust the sensitivity to the desired level using the [↑] and [↓] buttons.

- 1) Pressing the [↑] button one time increases the sensitivity setting by 1. Holding down the [↑] button rapidly increases the setting (in single increments) until the button is released. The level can increase to a maximum of 100.
- 2) Pressing the [↓] button one time decreases the sensitivity setting by 1. Holding down the [↓] button rapidly decreases the setting (in single decrements) until the button is released. The level can decrease to a minimum of 0.

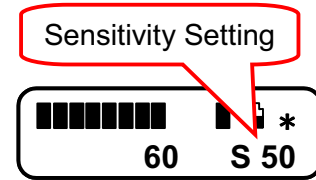

5. Using the Automatic Sensitivity Adjustment

It is possible to automatically set the sensitivity to an easy-to-hear level without the use of the [↑] and [↓] buttons.

- 1) Pull and hold the trigger for at least 1 second.
- 2) The sensitivity setting is automatically altered until the current reading reaches a level that is easy to hear.
- 3) When the trigger is released, the setting becomes fixed at the last automatically assigned sensitivity setting.



Hold for at least 1 second.

6. Turning the Laser Pointer ON and OFF



Use of controls or adjustments or performance of procedures other than those specified herein may result in hazardous radiation exposure.

The laser pointer assists in identifying the location of a detected leak.

- 1) Pressing and holding the [*] button causes the laser pointer to emit a laser beam, and a "*" mark appears in the display.

Note : The laser pointer only emits a laser beam while in detection mode. When modifying settings, saving data, recalling data, etc., it does not emit a beam.

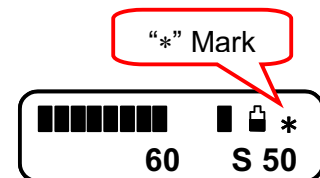

- 2) When the [*] button is released, the laser pointer beam is turned OFF and the "*" mark disappears from the display.



7. Estimating Leakage Amount

Estimating the leakage amount, which is based on the detection reading, can be performed by inputting the conditions in which **SonicMan** took the reading.

- 1) Set the Unit to Calculation Mode. (There are 2 ways to do this.)
 - (a) The calculation mode is entered automatically when a reading is taken if the automatic leakage amount calculation function ("Calc. Function") is set to "Auto". (See section 8.3 "Setting Leakage Amount Calculation".)
 - (b) To perform the estimated leakage amount calculation on previously saved data, first recall the saved data, then press the [Func.] button 1 time. (See section 7.10 "Recalling Saved Data".)

- 2) Input the Distance to the Leak

The [↑] and [↓] buttons are used to change the distance setting.

- (a) Pressing either the [↑] or the [↓] button 1 time increases or decreases the distance by 0.1 m, respectively. Pressing and holding increases or decreases the distance in 1.0 m increments.
- (b) The maximum distance that can be input is 25.5 m, and the minimum distance is 0.1 m.
- (c) Press the [ENT] button to lock in the data.

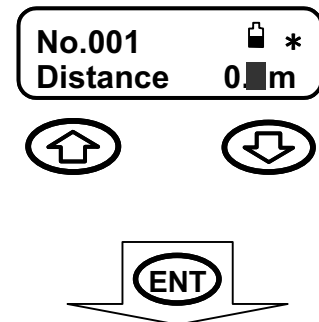

- 3) Select the Type of Leak Location

Choose from among flange, union, valve seat, screwed, copper jnt (piping joint), and others.

- (a) The different types are displayed in a scrolling list by pressing either the [↑] or [↓] buttons.
- (b) Select the type of location, and then press the [ENT] button.

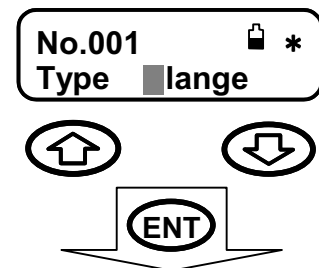

- 4) Select the Reading Direction

Select either "0° or ?" or "90°".

- (a) Scroll through the choices for direction by pressing either the [↑] or [↓] buttons.
- (b) Select "0° or ?" if the reading was taken directly facing the surface from which fluid is leaking or if the direction is unknown.
- (c) Select "90°" if the reading was taken perpendicular to the direction of the leak.
- (d) Select the direction in which the reading was taken, then press [ENT].

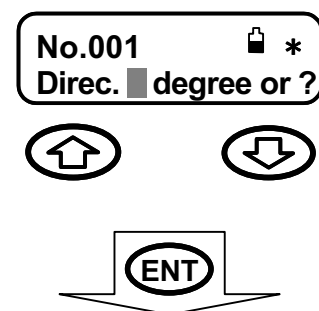

- 5) Select the Type of Fluid

Select from among air, carbon dioxide, nitrogen, helium and steam.

- (a) Scroll through the choices for the type of fluid by pressing the [↑] and [↓] buttons.
- (b) Select the type of fluid that is leaking, and then press the [ENT] button.

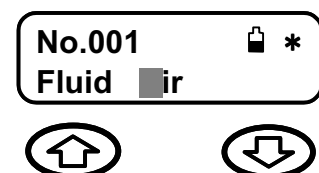

- (c) The result from the leakage amount calculation is displayed (L:---), then the display changes to the record number confirmation screen.

- 6) To Revise the Calculation Conditions.
Pressing the [Func.] button again allows for re-input of the calculation conditions as many times as desired.
- 7) To Cancel the Input of Calculation Conditions before Input is Complete
Pressing the [Func.] button causes the display to skip the conditions input screen and to jump to the record number confirmation screen.

8. Saving the Inspection Data in the Internal Memory

The reading value, sensitivity setting, estimated leakage amount and its conditions and the date of the inspection can be saved together with the record number in the internal memory.

- 1) Press the [Memory] Button While in Detection Mode
 - (a) If the automatic leakage amount calculation function ("Calc. Function") is set to "Auto":
 - (1) The display changes to the screen for input of the estimated leakage amount calculation conditions (Calculation Mode).
 - (2) Input the conditions in response to the questions that appear on the screen. (See section 7.7 "Estimating Leakage Amount".)
 - (3) After inputting the leak/reading conditions, the display changes to the record number confirmation screen.
 - (b) If the automatic leakage amount calculation function ("Calc. Function") is set to "Manual": The calculation mode is skipped, and the display jumps to the record number confirmation screen

2) Record Number Confirmation Screen

- (a) All calculation mode data is locked in (or skipped), and the cursor in the record number box begins blinking.
- (b) At this point, a number that is sequentially higher by one than the highest currently in memory is automatically displayed.

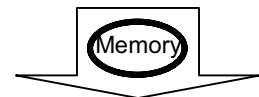
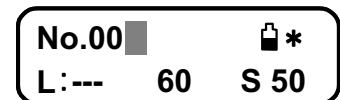

- 3) Saving using an Automatically Displayed Record Number
 - (a) Press the [Memory] button one more time.
 - (b) The message "Complete Data Store" is momentarily displayed while the unit saves the inspection data. Press [Memory] again to return to the detection mode.



4) Saving using a Different Record Number

- (a) The [↑] and [↓] buttons are used to modify the record number to be saved.
- (b) It is possible to set record numbers from 000 to 999.
- (c) Press the [Memory] button one more time.
- (d) The message "Complete Data Store" is displayed while the unit saves the inspection data. Press [Memory] again to return to the detection mode.

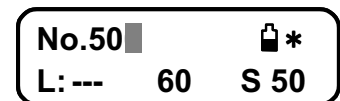

5) Trying to Save using a Record Number in Which Data has Already Been Saved

- (a) **SonicMan** will query: "Over write?"
- (b) To destroy the previous data and save the new data (overwrite), continue by pressing the [Memory] button one more time.
- (c) To save without overwriting, use the [↑] and [↓] buttons to select a different record number.

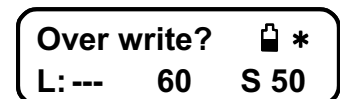

6) Canceling a Data Save (Destroy the Present Reading's Date)

- (a) With the automatically displayed record number visible on the screen, press the [↑] button one time. "CSL", meaning "cancel", is displayed.
- (b) Press the [Memory] button one more time.
- (c) The data is not saved (data is lost). Press [Memory] again to return to the detection mode.

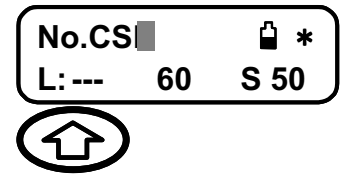

7) Flow Chart.

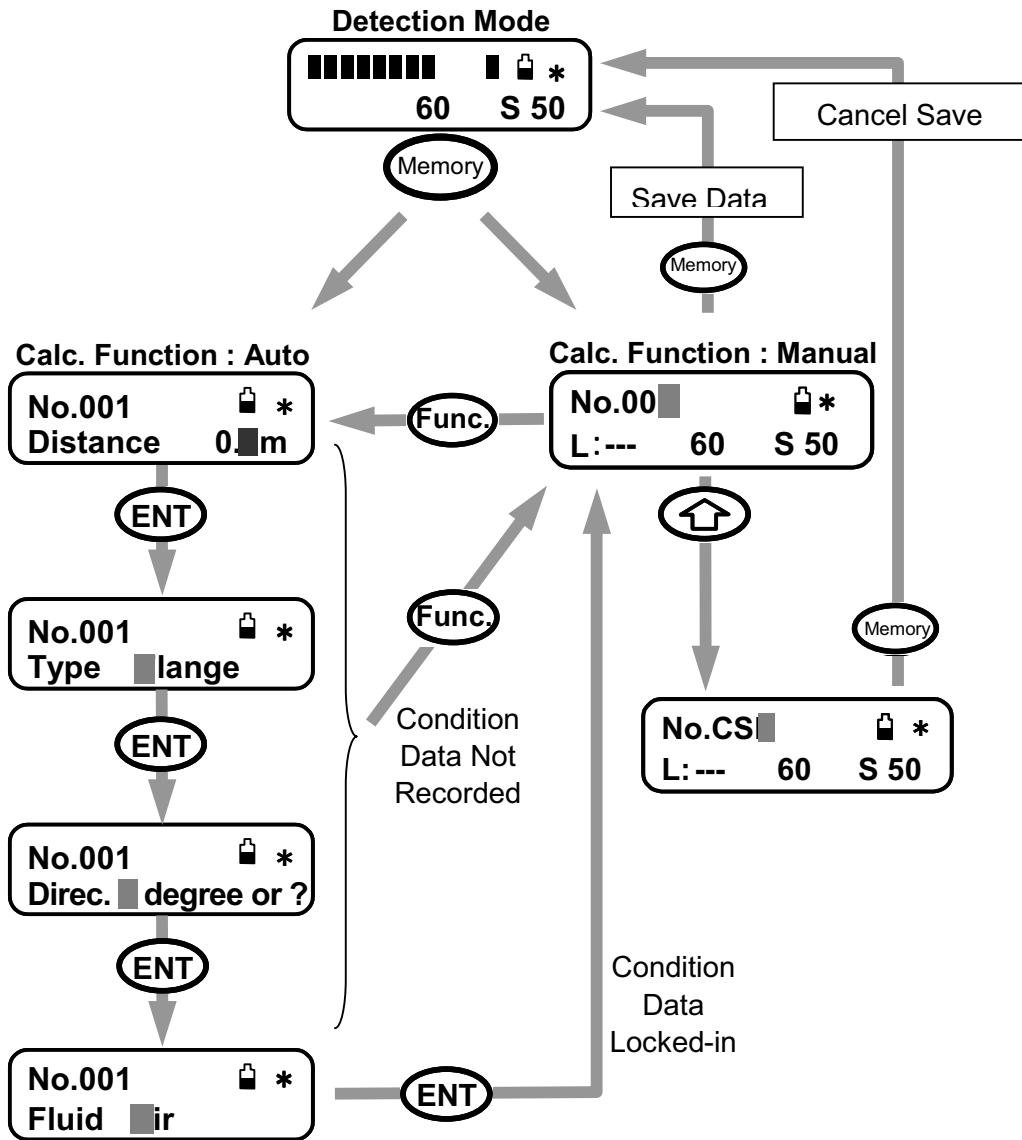





9. Recalling Saved Data

It is possible to recall and display data that has been saved in the internal memory.

- 1) While in detection mode, press and hold the [Memory] button for at least 1 second. The saved record with the highest record number will be displayed.  Hold Down
- 2) A different record can be displayed by using the [↑] and [↓] buttons.
 - (a) Pressing either the [↑] or the [↓] button one time displays either the next or the previous record number, respectively. (Record numbers that contain no saved data are skipped over and not displayed.)
 - (b) Pressing and holding down either the [↑] or the [↓] button for at least one second rapidly scrolls through the records.
 - (c) The record displayed following the saved record with the highest number (last record) will be the saved record with the lowest number (first record).
 - (d) The record displayed before the saved record with the lowest number (first record) will be the saved record with the highest number (last record).

10. Deleting Saved Data

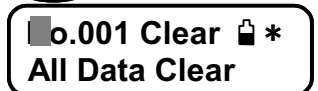
The data in the internal memory can be deleted one record at a time, or all saved data can be deleted at once.

- 1) Following the instructions in section 7.10 "Recalling the Saved Data", recall and display the saved data.
- 2) Use the [↑] and [↓] buttons to select the record number to be deleted. (When deleting all saved data, there is no need to select a record number.)
- 3) Press both the [Func.] and the [Memory] button at the same time. A menu offering the choices of deleting only the selected record number ("No.### Clear" - the top of the screen) or of deleting all saved data ("All Data Clear" - the bottom of the screen) is displayed.   
- 4) Use the [↑] and [↓] buttons to move the cursor to the desired action, in either the upper half or the lower half of the screen.
- 5) Press the [ENT] button to delete the data.  Delete Data
 - (a) After deleting one data record, the display returns to the data recall screen of the highest record number.
 - (b) When there is no more saved data or when all data has been deleted, the unit returns to detection mode.
- 6) To cancel the deletion of saved data at this stage:  Cancel the Deletion
 - (a) Press the [Func.] button.
 - (b) The display returns to the saved data recall screen.

11. Operation Flow Chart

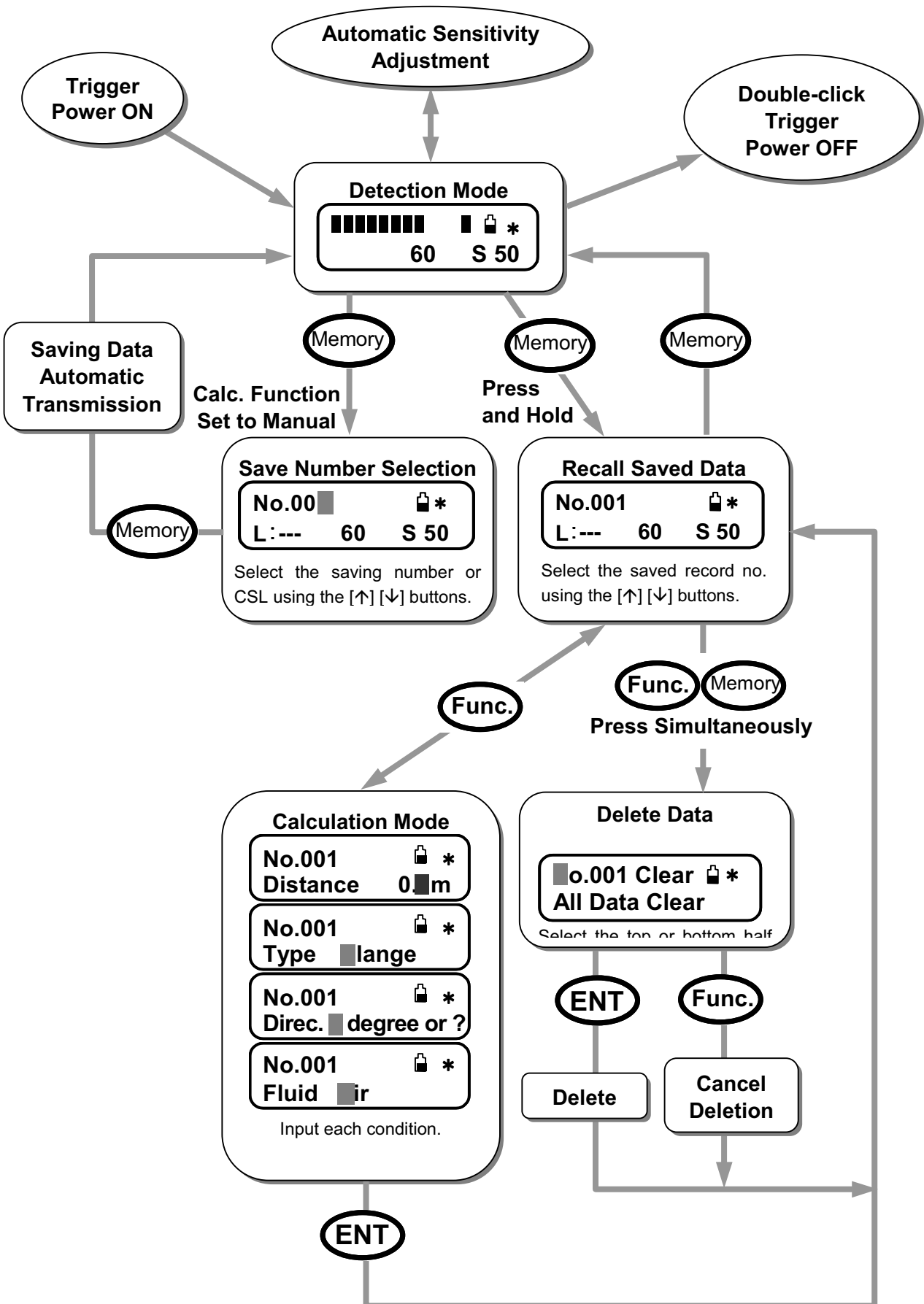

8 Optional Settings and Adjustments

How to Set the **SonicMan** Functions

While in detection mode, press the [Func.] button.

1. Display of Remaining Battery Time

A 10-level indicator of current battery charge is displayed.

- 1) Press the [ENT] button to move the display to the next setting item.
- 2) Press the [Func.] button to return to detection mode.

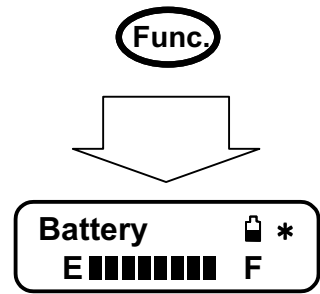

2. Turning ON and OFF the Backlight (Factory default is "OFF")

To set the screen backlight to "ON" and "OFF":

- 1) Press the [↑] and [↓] buttons to switch between "ON" and "OFF", which turns the backlight on and off.
- 2) Press the [ENT] button to move to the next setting item.
- 3) Press [Func.] to return to detection mode.

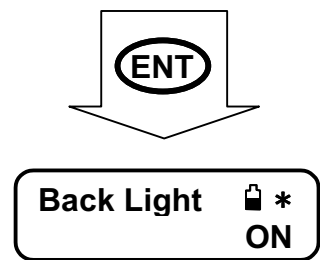

3. Setting Leakage Amount Calculation to "Automatic" (Factory default is "MANUAL")

To set whether to enter calculation mode automatically ("Auto") when a reading is taken, or to enter data manually ("Manual") at some other time:

- 1) Press [↑] and [↓] to switch between "Auto" and "Manual".
- 2) Press [ENT] to move the display to the next setting item.
- 3) Press [Func.] to return to detection mode.

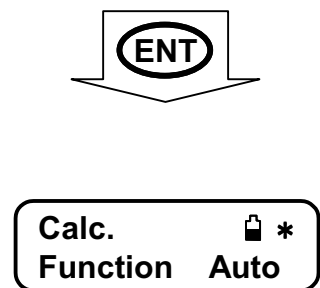

4. Setting the Automatic Volume Control (Factory default is "OFF")

When it is turned ON, this feature is designed to protect the ear by instantaneously throttling the headphone output volume when a sudden loud sound is generated. The headphone volume is independent of the sensitivity setting function. Therefore, throttling the headphone volume has no influence on the leak detection reading. Once the loud sound ceases, the volume reverts to its normal setting. However, if the loud sound is continuously generated, the headphone volume is repeatedly throttled and the sound may grow very small.

- 1) Press [↑] and [↓] to switch between "ON" and "OFF".
- 2) Press [ENT] to move the display to the next setting item.
- 3) Press [Func.] to return to detection mode.

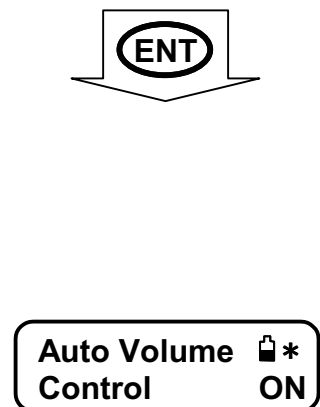

8. Optional Settings and Adjustments

5. **Setting the Automatic Power OFF Time Delay** (Factory default is "5 min")

This feature automatically turns the **SonicMan** power OFF, after the prescribed length of time has elapsed in which the **SonicMan** has not been operated.

- 1) Press the [↑] and [↓] buttons to raise or lower the power OFF time delay from 0 to 60 minutes.
- 2) If the time delay is set to 0 minutes, the automatic power OFF feature is disabled.
- 3) Press [ENT] to move the display to the next setting item.
- 4) Press [Func.] to return to detection mode.



6. **Adjusting the Headphone Output Volume**

This feature allows the selection of the headphone output volume. The volume is adjusted with the [↑] (UP) and the [↓] (DOWN) buttons. As there is no level indicator, perform the adjustment while monitoring the sound from the headphone.

- 1) Pressing either the [↑] or the [↓] button one time adjusts the level one step. If the button is pressed and held down, the level is continuously adjusted until the button is released. To go from the minimum to the maximum, the button must be held down continuously for approximately 7 seconds.
- 2) Press [ENT] to move the display to the next setting item.
- 3) Press [Func.] to return to detection mode.

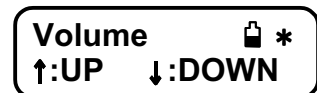

7. **Setting the Date & Time**

- 1) Pressing either the [↑] or the [↓] button to set the date and time.
- 2) The setting item moves to right side with [ENT] button.
- 3) Press [ENT] to move the display to the next setting item.
- 4) Press [Func] to return to detection mode.

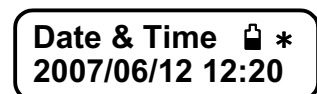

8. Optional Settings and Adjustments

8. Setting Data Communication Way.

SO2(-EX) has 2 options to communicate inspection data. One is using cable (Cable com.). The other one is using Bluetooth function (RF com.)

If you selected Bluetooth function (RF com.), SO2(-EX) communicate automatically with **SonicLogger** (PDA).

Data Com.  *
RF Com.

- 1) Pressing either the [↑] or the [↓] button to select the setting.
- 2) Press [ENT] to move the display to the next setting item.
- 3) Press [Func] to return to detection mode.



9 How to Use the Accessories

1. How to Use the Nozzle

- 1) Attach the nozzle to the tip of the **SonicMan**.



- 2) Use it to help pinpoint the leak location.
Using the **SonicMan** with the nozzle attached greatly enhances its directional properties, which is useful for locations where there is a great deal of background noise, or for cases in which one wishes to further home in on the leak location. Use of the nozzle makes it possible to collect the ultrasonic waves in the direction in which the **SonicMan** is pointing with greater accuracy.
- 3) When not using the nozzle, store it in the holster.

2. How to Use the Holster

- 1) Take out the holster's belt loop and attach it to the belt ①.
- 2) Insert the **SonicMan** unit into the holster and close the band ②.
- 3) The nozzle can be removed by pulling it out of the bottom of the holster ③.



10 Troubleshooting

When the product does not perform as it should, troubleshoot the problem using the following list. After checking the following items and performing the prescribed corrective actions, if the product still does not perform as it should, contact the local **TLV** technical sales representative with details of the malfunction status.

1. The Battery Does Not Charge

- 1) Are the specialized charger and battery pack being used?
Use only the included charger and battery pack.
- 2) Is the charger power cord connected to the unit?
Insert the included power cord securely into the unit.
- 3) Is power being supplied to the electrical outlet?
It may be that the main power source is turned off. Make sure that it is turned on.

2. Even Though the Power is ON, Nothing is Displayed

- 1) Is the battery pack attached?
Attach the included battery pack, making sure that it is fully charged.
- 2) Is the battery pack being used the one the was included in the **SonicMan** set?
Attach the battery pack that was included.
- 3) Is the battery pack fully charged?
Charge the battery pack with its charger.
- 4) Is the trigger being pulled all the way?
Pull the trigger until a "click" is heard.
- 5) Is the screen contrast set too light?
Press the laser pointer button. If a laser beam is emitted, the power is ON.
This means that the screen is simply not visible. Readjust the screen contrast setting.

3. The Unit Does Not Turn Off, Even When the Power is OFF

- 1) Is the unit in Detection mode?
The power cannot be turned OFF when the unit is in a mode other than detection mode, for example when it is in calculation mode, recalling saved data or any of the various setting modes.
Return to detection mode before turning the power OFF.
- 2) Is the trigger being double-clicked?
Double-click the trigger, with both clicks occurring within a 1 second time period.
A double-click that takes longer than 1 second for both clicks will not turn the unit OFF.
- 3) Is the trigger being pulled all the way?
Pull the trigger until a "click" is heard.

4. No Sound Can Be Heard through the Headphone

- 1) Are the headphone being used the ones that were included in the **SonicMan** set?
There may be no sound output if headphone other than the included headphone are used. Be sure to use only the included headphone.
- 2) Are the headphone inserted snugly into the headphone jack?
Insert the headphone firmly all the way into the headphone jack.

5. No Laser Beam is Emitted from the Laser Pointer

- 1) Is the unit in detection mode?
Even if the laser pointer is set to ON, if the unit is in a mode other than detection mode, no laser beam will be emitted. Return the unit to detection mode and again check the status of the laser beam.
- 2) Is the “*” mark displayed on the screen?
When the laser pointer is ON, the “*” mark is displayed on the screen.
Press the [*] button, causing the “*” mark to be displayed, and again check the status of the laser beam.

6. When Saving, the Automatically Created Record No. does not Begin at 001

- 1) Has inspection data been saved previously?
The automatically generated record number is one number larger than the highest existing record number.
Using the saved data recall function, check the saved data and delete all unnecessary data that is found.

7. **SonicMan** Cannot Communicate with the **SonicLogger** when Attempting Data Save

- 1) Are the communications cable connectors securely attached?
Insert both the round connector (**SonicMan**) and the flat connector (PDA) securely into the ports of their respective components.
- 2) Is the communications cable used the one that was included in the **SonicMan** set?
It may not operate correctly if a cable other than the included cable is used.
Be sure to attach only the included communications cable.
- 3) Does the **SonicLogger** SYNC screen display the message, “Waiting to connect”?
Using the Sync screen connection is only necessary when communicating with **SonicManager**.
To communicate with the **SonicMan**, it is necessary to set it to “Stopping”.
To set it to “Stopping”, tap the Start/Stop button on the **SonicLogger** Sync screen.
If communication is still not possible, turn the PDA power OFF, then initialize **SonicLogger** again.

11 Specifications

1. SonicMan

Model Name	: SO2 (Standard type) : SO2-EX (Explosion proof type)
Detection-related	
Sensor	: Ultrasonic microphone
Detector Center Frequency	: 40 kHz
Sensitivity Adjustment	: 100 levels
Laser Pointer	
Classification	: Class 2 laser product
Maximum Output	: 1 mW
Pulse Width/Frequency	: 300ns/150kHz
Medium	: Laser diode
Emission Wavelength	: 657 nm
Display	: 16 characters x 2 lines dot matrix LCD (with yellow backlight)
RF Communication	
Frequency Range	: 2.4 – 2.4835GHz
The Transmission Scheme	: Frequency-Hopping Spread-Spectrum(FHSS)
TX Power	: 4dBm Max.
Power Source	: Rechargeable nickel-metal-hydride battery 2.4V 1650mAh Model SO-101 (Standard type) SO2-101EX (Explosion proof type)
Continuous Use Time (After full charge)	: Approx. 11 hours (both backlight and laser pointer OFF) : Approx. 8 hours (backlight ON, laser pointer OFF) : Approx. 6 hours (both backlight and laser pointer ON)
Allowable Temperature and Relative Humidity Range	
When in Use	: 0 to 40 ° C / Less than 80%RH (non-condensing)
When in Storage	: -5 to 50 ° C / Less than 85%RH (non-condensing)
Dimensions	: Total length:180mm height:170mm width:85mm
Weight	: Approx. 550g

2. Explosion Proof Specification of SO2-EX

ATEX

ATEX Marking	CE 0081 EX II1G
Type of Protection	EEx ia IIC T4
Protection Methods	Intrinsically safe "ia"
Gas Groups	IIC
Temperature Codes	T4(135 C)
Ambient Temperature	Max 40 C



Type of Protection	Ex ia IIC T4
Protection Methods	Intrinsically safe "ia"
Gas Groups	IIC
Temperature Codes	T4(135 C)
Ambient Temperature	Max 40 C

IEC-Ex

Type of Protection	Ex ia IIC T4
Protection Methods	Intrinsically safe "ia"
Gas Groups	IIC
Temperature Codes	T4(135 C)
Ambient Temperature	Max 40 C

3. Charger (Model SO1-201)

Charging Time	: Approx.1 hour maximum
Full Charge Detection System	: ΔV Detection system; After full charge is completed, it moves to trickle charge
"Refresh" Feature	: Discharge Time approximately 1 hour maximum After completing the discharge, it automatically switches to charging mode
Input	: 100-240V AC 50 / 60 Hz
Dimensions	: Width:130mm depth:90mm height:60mm
Weight	: 270 g

12 Product Warranty

1. Warranty Period

One year following product delivery.

2. Warranty Coverage

TLV CO., LTD. warrants this product to the original purchaser to be free from defective materials and workmanship. Under this warranty, the product will be repaired or replaced at our option, without charge for parts or labor.

This product warranty will not apply to cosmetic defects, nor to any product whose exterior has been damaged or defaced; nor does it apply in the following cases:

- 1) Malfunctions due to improper installation, use, handling, etc., by other than **TLV CO., LTD.** authorized service representatives.
- 2) Malfunctions due to dirt or scale.
- 3) Malfunctions due to improper disassembly and reassembly, dropping or other impact, or due to inadequate inspection and maintenance by other **TLV CO., LTD.** authorized service representatives.
- 4) Malfunctions due to disasters or forces of nature.
- 5) Accidents or malfunctions due to any other cause beyond the control of **TLV CO., LTD.**

3. Concerning Calibration

SonicMan is a precision measuring instrument.

It is recommended that it be calibrated periodically.

- Interval Between Calibrations : 2 years
- Calibration Method : Calibration is performed using a specialized calibration apparatus at the **TLV** plant.

Contact the local **TLV** technical sales representative.

For the latest information about TLV products, consulting services and customer support, visit our homepage on the World Wide Web: <http://www.tlv.com>.

Worldwide offices:

TLV CORPORATION
6701K North Park Boulevard
Charlotte, North Carolina 28216 USA
Phone: (1)-704-597-9070 Fax: (1)-704-597-9082
Call 1-800-“ TLV-TRAP”

TLV EURO ENGINEERING GmbH

Main Office	UK Office
Draimler-Benz-Strasse 16-18	Priory Lodge, London Road
74915 Waibstadt	Cheltenham, Glos.
Germany	GL52 6HQ
Phone: (49)-(0)7263-9150-0	Phone: (44)-(0)1242-221180
Fax: (49)-(0)7263-9150-50	Fax: (44)-(0)1242-221055

TLV EAST ASIA PTE LTD
66 Tannery Lane
#01-03 CM Sindo Building, Singapore 347805
Phone: (65)-7474600 Fax: (65)-7420345

TLV INTERNATIONAL INC
881 Nagasuna, Noguchi, Kakogawa, Hyougo 675 Japan
Phone: (81)-(0)794-27-1818 Fax: (81)-(0)794-25-7033

Manufacturer/Publisher

TLV INTERNATIONAL INC
881 Nagasuna, Noguchi, Kakogawa, Hyougo 675 Japan
Phone: (81)-(0)794-22-1122 Fax: (81)-(0)794-22-0112