

Report No.	S0715517
Specifications	FCC Part 15 - Notification
Test Method	ANSI C63.4 1992
Applicant address	23, Lane 2, Jing Wu Road, Taichung, R.O.C.
Applicant Items tested	Sekaku Electron Industry Co., Ltd. WIRELESS MICROPHONE RECEIVER
Model No.	WR-211R
Results	As detailed within this report
Sample received date	04 / 14 / 1998 (month / day / year )
Prepared by	<u>Stephen Chen</u> project engineer
Authorized by	<u>Jacob Lin</u> Vice General Manager (Jacob Lin )
Issue date	<u>Apr. 30, 1998</u> (month / day / year )
Modifications	None
Tested by	Training Research Co., Ltd.
Office at	2F, No. 571, Chung Hsiao E. Road, Sec.7, Taipei, Taiwan
Open site at	No. 5-3, Lane 21, Yen Chiu Yuan Rd., Sec.4, Taipei Taiwan

**Conditions of issue:**

- (1). **This test report shall not be reproduced except in full, without written approval of TRC. And the test result contained within this report only relate to the sample submitted for testing.**
- (2). **This report must not be used by the client to claim product endorsement by NVLAP or nay agency of U.S. Government.**

★ FCC ID : H38WR-211R

# Contents

## Chapter 1 Introduction

Description of EUT.....	3
Configuration of Test Setup.....	4
List of Support Equipment.....	5

## Chapter 2 Conducted Emission Test

Test Condition and Setup.....	6
Conducted Test Placement.....	7

## Chapter 3 Radiated Emission Test

Test Condition and Setup.....	8
.Radiated Test Placement.....	9

## Appendix A :

Conducted test result.....	10
----------------------------	----

## Appendix B :

Radiated test result .....	13
----------------------------	----

## ***Chapter 1 Introduction***

### ***Description of EUT :***

These products are professionally designed wireless microphone and receiver system made-up of diverse circuit. It can receive one frequency between 174 MHz and 216 MHz. This microphone is worn by a performer and other participants in a program, filming , reporting .....etc.

### ***Connection of EUT :***

- (1)Connect the EUT's audio output to guitar amplifier by an audio cable .
- (2)Plug the adapter into the EUT.
- (3)Pull out the antenna vertically .

### ***Test method :***

There are three EUTs tested which are operatd at 174.1, 194.6, 214 MHz separately. Turn on the receiver and the speaker . There is a signal generator connected with a field probe , which can transmit the receiving frequency , put near the EUT . The test data also showed three EUT's emission .

(If the emission is close to the ambience, the resolution BW and view resolution will be reduced and the data will be recorded by detection of maximum hold peak mode.)

### ***Statement of transition provision for compliance with the rules***

The EUT receives the signal which only send from the wireless microphone. The EUT won't be influenced by the transition provision , it will be continue to comply with the regulations of the FCC Part 15 . ( The relative wireless microphone FCC ID :H38VXM-198TS).

***The testing configuration of test setup is showing in the next page.***

**Configuration of test setup**

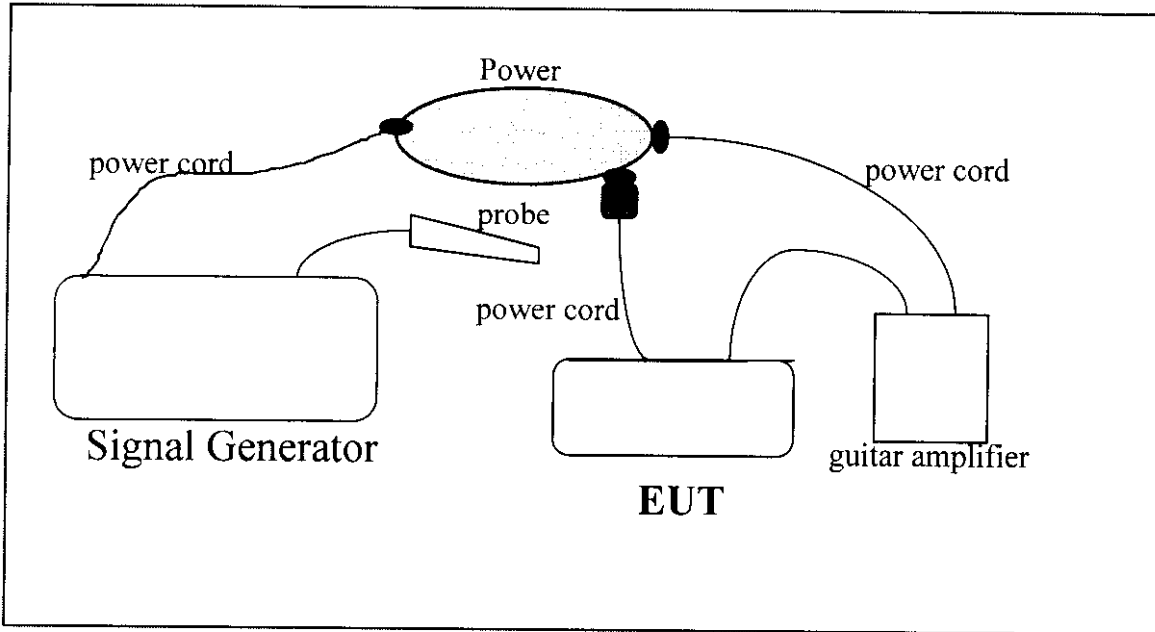

**Connections :**

- \* The Adapter 120Vac/15Vdc,400 mA, 190 cm long, non-shielded.
- \* The Audio cable dual head 6.3Ø, 126 cm, non-shielded.

*List of support equipment*

**Conducted (Radiated) test :**

**Guitar Amplifier : Dragon (KIKUTANI MUSIC COL,LTD. )**

Model No. : GA-10 ( RMS-100 )  
Power type : 110vac 60Hz  
Power code : Non-shield , 1.2m long

**Field Probe : HP Field Probe 30MHz~1GHz**

Model No. : HP11940A  
Serial No. : 2650A03038

**Signal Generator : HP 9KHz~4000MHz**

Model No. : 8648D  
Serial No. : 3613A00117  
Power type : 110vac 60Hz  
Power cord : Non - Shielded

## Chapter 2 Conducted emission test

### Test condition and set up :

All the equipment is placed and setup according to the ANSI C63.4 - 1992 . The EUT is assembled on a wooden table which is 80 cm high , is placed 40 cm from the back-wall which is a vertical conducting plane . One LISN is for EUT ,the other LISN is for support equipment. They are all placed on the conductive ground .The EUT's LISN is connected to a line switch box for selecting L1 or L2 ,then connect to a preamplifier and spectrum.

The spectrum scans from 450KHz to 30MHz . Conducted emission levels are detected at max. peak mode . But if the max. peak mode failed ,it will be measured by CISPR's quasi-peak detection mode .

While testing, there is a worst-emission plot printed at peak detection mode ,and there are more than 6 highest emissions relative to limit recorded. The plot is kept as the original data, not included in test report .

### List of test Instrument :

Instrument Name	Model No.	Brand	Serial No.	Calibration Date	
				Last time	Next time
Spectrum analyzer	8591EM	H P	3619A00821	08/29/97	08/29/98
LISN (EUT)	3825/2	EMCO	9411-2284	05/15/97	05/15/98
LISN (Support E.)	3825/2	EMCO	9210-2007	05/15/97	05/15/98
Preamplifier	8447F	H P	2944A03706	05/13/97	05/15/98
Line switch box	AC1-003	TRC	-----	05/15/97	05/15/98
Line selector	AC1-002	TRC	-----	05/15/97	05/15/98

The level of confidence of 95% ,the uncertainty of measurement of conducted emission is  $\pm 2.4$  dB .

Test Result : Pass (Appendix A)

### **Chapter 3 Radiated emission test**

**Test condition and set up :**

**Pretest :** Prior to the final test (OATS test) ,the EUT is placed in a shielded enclosure ,GTEM, and scan from 30MHz to 1GHz.This is done to ensure the radiation exactly emits form the EUT.

**Final test :** Final radiation measurements is made on a **3 - meter, open-field** test site. The EUT is placed on a nonconductive table which is 0.8 m height, the top surface is 1.0 x 1.5 meter. All the placement is according to ANSI C63.4 - 1992.

The spectrum is examined from 30 MHz to 1000 MHz measured by HP spectrum.

The EMCO whole range Antenna is used to measure frequency from 30 MHz to 1GHz.The final test is used the spectrum HP 8594EM .

Measure more than six top marked frequencies generated form pretest by computer step by step at each frequency . The EUT is rotated 360 degrees, and antenna is raised and lowered from 1 to 4 meter to find the maximum emission levels. The antenna is used with both horizontal and vertical polarization.

Appropriated preamplifier which is made by TRC is used for improving sensitivity and precautions is taken to avoid overloading .The spectrum analyzer’s 6dB bandwidth is set to 120 K Hz , and the EUT is measured at quasi-peak mode.

If the emission is close to the frequency band of ambience ,the data will be rechecked by the tester and the corrected data will be written in the test data sheet. If the emission is just within the ambience ,the data from GTEM will be taken as the final data.

**List of test Instrument :**

Instrument name	Model No.	Brand	Serial No.	Calibration Date	
				Last	Next
Spectrum analyzer	8568B	H P	3004A18617	05/15/97	05/15/98
Quasi-peak Adapter	85650A	H P	2521A00984	05/15/97	05/15/98
RF Pre-selector	85685A	H P	2947A01011	05/15/97	05/15/98
Spectrum analyzer	8594EM	H P	3619A00198	08/07/97	08/07/98
Antenna(30M-2G Hz)	3142	EMCO	9610-1094	10/30/97	10/30/98
Open test side (Antenna ,Amplify, cable calibrated together )				05/15/97	05/15/98

The level of confidence of 95% ,the uncertainty of measurement of radiated emission is  $\pm 4.96$  dB .

**Test Result : Pass (Appendix B)**

**Appendix A****Conducted Emission Test Result ( Frequency 174.1 MHz )**

Testing room : Temperature : 24 ° C      Humidity : 50 % RH

**Line 1**

<i>Frequency (MHz)</i>	<i>Amplitude (dBuV)</i>	<i>Limit (dBuV/m)</i>	<i>Margin (dB)</i>
0.450	30.52	48	-17.48
14.066	16.38	48	-31.62
21.675	16.72	48	-31.28
22.405	19.23	48	-28.77
22.769	20.97	48	-27.03
23.718	22.04	48	-25.96
24.009	22.31	48	-25.69
28.015	19.08	48	-28.92
***			

**Line 2**

<i>Frequency (MHz)</i>	<i>Amplitude (dBuV)</i>	<i>Limit (dBuV)</i>	<i>Margin (dB)</i>
0.450	36.39	48	-11.61
1.336	19.03	48	-28.97
17.435	16.95	48	-31.05
21.675	17.92	48	-30.08
22.332	17.97	48	-30.03
22.769	23.28	48	-24.72
23.718	21.78	48	-26.22
23.936	21.61	48	-26.39
24.665	19.09	48	-28.91
27.142	17.57	48	-30.43



( Frequency 194.6 MHz )

**Line 1**

<i>Frequency (MHz)</i>	<i>Amplitude (dBuV)</i>	<i>Limit (dBuV/m)</i>	<i>Margin (dB)</i>
0.450	31.59	48	-16.41
1.410	16.90	48	-31.1
10.028	15.96	48	-32.04
22.405	18.71	48	-29.29
22.769	20.40	48	-27.6
23.718	21.22	48	-26.78
24.374	21.18	48	-26.82
24.884	17.91	48	-30.09
28.015	18.13	48	-29.87
***			

**Line 2**

<i>Frequency (MHz)</i>	<i>Amplitude (dBuV)</i>	<i>Limit (dBuV)</i>	<i>Margin (dB)</i>
0.450	35.71	48	-12.29
1.262	19.11	48	-28.89
1.927	15.17	48	-32.83
22.405	19.80	48	-28.2
22.842	22.55	48	-25.45
23.936	21.42	48	-26.58
24.665	19.18	48	-28.82
27.506	16.90	48	-31.1
28.015	20.61	48	-27.39
***			

( Frequency 214 MHz )

**Line 1**

<i>Frequency (MHz)</i>	<i>Amplitude (dBuV)</i>	<i>Limit (dBuV/m)</i>	<i>Margin (dB)</i>
0.450	30.82	48	-17.18
1.336	16.35	48	-31.65
2.591	15.97	48	-32.03
9.808	16.20	48	-31.8
22.259	17.47	48	-30.53
24.593	19.04	48	-28.96
***			

**Line 2**

<i>Frequency (MHz)</i>	<i>Amplitude (dBuV)</i>	<i>Limit (dBuV)</i>	<i>Margin (dB)</i>
0.450	36.27	48	-11.73
1.484	17.06	48	-30.94
1.927	15.36	48	-32.64
6.277	15.76	48	-32.24
10.102	16.63	48	-31.37
14.432	16.67	48	-31.33
15.165	17.33	48	-30.67
23.353	17.94	48	-30.06
28.088	16.95	48	-31.05
29.542	18.88	48	-29.12

**Appendix B**

**Radiated Emission Test Result :( Frequency 174.1 MH Horizontal)**

Test Conditions:

Testing room : Temperature : 25° C Humidity : 60% RH

Testing site : Temperature : 22 ° C Humidity : 80 % RH

Frequency	Reading Amplitude	Ant. Height	Table	Correction Factors	Corrected Amplitude	Class B limit	Margin
MHz	DBuV	m	degree	dB/m	dBuV/m	dBuV/m	dB

109.081	44.28	4	71	-13.22	31.06	43.50	-12.44
163.409	43.94	4	78	-11.65	32.29	43.50	-11.21
218.305	38.67	4	306	-8.97	29.70	46	-16.3
325.015	38.58	1	243	-19.03	19.55	46	-26.45
376.251	37.13	4	264	-17.36	19.77	46	-26.23
450.801	45.74	4	218	-16.25	29.49	46	-16.51
490.221	43.71	1	255	-15.02	28.69	46	-17.31
***							

Note:

1. Margin = Amplitude - limit, *if margin is minus means under limit.*
2. Corrected Amplitude = Reading Amplitude - Correction Factors
3. Correction factor = Antenna factor + ( Cable Loss - Amplitude gain)  
(For example : 30MHz correction factor = 15.5 + (-15.26) = 0.24 dB/m)

***Radiated Emission Test Result :(Vertical)***

Frequency	Reading	Ant.	Table	Correction	Corrected	Class B	Margin
	Amplitude	Height		Factors	Amplitude	limit	
MHz	dBuV	m	degree	dB/m	dBuV/m	dBuV/m	dB
109.081	48.17	1	19	-13.22	34.95	43.50	-8.55
163.409	41.09	1	285	-11.65	29.44	43.50	-14.06
218.305	36.82	1	153	-8.97	27.85	46	-18.15
325.015	38.33	4	88	-19.03	19.30	46	-26.7
376.251	38.08	4	47	-17.36	20.72	46	-25.28
450.801	44.21	4	223	-16.25	27.96	46	-18.04
490.221	44.67	1	154	-15.02	29.65	46	-16.35
***							

**Radiated Emission Test Result :( Frequency 194.6 MH Horizontal)**

Frequency	Reading Amplitude	Ant. Height	Table	Correction Factors	Corrected Amplitude	Class B limit	Margin
MHz	dBuV	m	degree	dB/m	dBuV/m	dBuV/m	dB
136.870	46.75	1.00	42	-13.03	33.72	43.50	-9.78
162.290	40.71	1.00	136	-11.69	29.02	43.50	-14.48
170.499	38.83	1.00	253	-11.35	27.48	43.50	-16.02
205.303	38.62	1.00	106	-9.57	29.05	43.50	-14.45
265.654	37.11	1.00	301	-6.64	30.47	46	-15.53
324.431	57.89	1.00	206	-19.04	38.85	46	-7.15
410.608	56.28	1.00	77	-17.03	39.25	46	-6.75
***							

**Radiated Emission Test Result :( Frequency 194 MH Vertical)**

Frequency	Reading	Ant.	Table	Correction	Corrected	Class B	Margin
	Amplitude	Height		Factors	Amplitude	limit	
MHz	dBuV	m	degree	dB/m	dBuV/m	dBuV/m	dB
136.870	47.41	1.00	352	-13.03	34.38	43.50	-9.12
162.290	41.57	1.00	241	-11.69	29.88	43.50	-13.62
170.499	46.08	1.00	205	-11.35	34.73	43.50	-8.77
205.303	38.54	1.00	52	-9.57	28.97	43.50	-14.53
265.654	42.81	1.00	2	-6.64	36.17	46	-9.83
324.431	51.11	1.00	219	-19.04	32.07	46	-13.93
410.608	52.21	1.00	194	-17.03	35.18	46	-10.82
***							

**Radiated Emission Test Result :( Frequency 214 MH Horizontal)**

Frequency	Reading	Ant.	Table	Correction	Corrected	Class B	Margin
	Amplitude	Height		Factors	Amplitude	limit	
MHz	dBuV	m	degree	dB/m	dBuV/m	dBuV/m	dB
51.891	37.10	1	96	-12.41	24.69	40	-15.31
151.308	43.82	1	78	-12.41	31.41	43.50	-12.09
170.499	39.03	1	224	-11.35	27.68	43.50	-15.82
227.264	37.02	1	284	-8.43	28.59	46	-17.41
315.041	55.02	1	130	-19.03	35.99	46	-10.01
379.303	40.03	1	267	-17.36	22.67	46	-23.33
450.603	40.21	1	24	-16.26	23.95	46	-22.05
***							

**Radiated Emission Test Result :( Frequency 214MHz Vertical)**

Frequency	Reading Amplitude	Ant. Height	Table	Correction Factors	Corrected Amplitude	Class B limit	Margin
MHz	DBuV	m	degree	dB/m	dBuV/m	dBuV/m	DB
51.891	38.18	1	76	-12.41	25.77	40	-14.23
151.308	44.16	1	138	-12.41	31.75	43.50	-11.75
170.499	44.07	1	182	-11.35	32.72	43.50	-10.78
227.264	37.09	1	241	-8.43	28.66	46	-17.34
315.041	40.04	1	83	-19.03	21.01	46	-24.99
379.303	43.56	1	35	-17.36	26.20	46	-19.80
450.603	47.71	1	317	-16.26	31.45	46	-14.55
***							

**Final statement :**

***This test report, measurements made by TRC are traceable to the NIST.***



## **The emissions measurement from 1-2 GHz**

Final radiation measurements were made on a one-meter, open-field test site. The EUT system was placed on a nonconductive turntable which is 0.8 meters height, top surface 1.0 x 1.5 meter.

The spectrum was examined from 1 GHz to 18GHz using an Hewlett Packard 8592A Spectrum Analyzer, EMCO Horn Antenna (Model 3115) for 1 G - 18 GMHz.

During testing , the EUT was rotated 360 degrees to find the maximum emission levels. Measurements were taken using both horizontal and vertical antenna polarization.

Appropriate preamplifiers were used for improving sensitivity and precautions were taken to avoid overloading or desensitizing the spectrum analyzer. No post-detector video filters were used in the test. The spectrum analyzer's 6 dB bandwidth was set to 1 MHz (spectrum was examined from 1 GHz to 18GHz) and the analyzer was operated in the maximum hold mode. There is a signal generator connected with a field probe , which can transmit the receiving frequency , put near the EUT .

### **The test result :**

There are no emission can be detected .