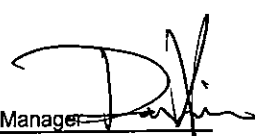
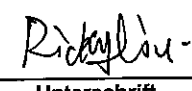

Prüfbericht - Nr.: 16015131 001		Seite 1 von 22 <i>Page 1 of 22</i>
<i>Test Report No.:</i>		
Auftraggeber: <i>Client:</i>	Seikaku Technical Group Limited Offshore Chambers, P. O. Box 217, Apia, Samoa	
Gegenstand der Prüfung: <i>Test item:</i>	Wireless Microphone Receiver	
Bezeichnung: <i>Identification:</i>	WR-108DR RM200 (PROEL)	FCC ID: <i>FCC ID</i> H38WR-108DR-
Wareneingangs-Nr.: <i>Receipt No.:</i>	173040862	Eingangsdatum: <i>Date of receipt:</i> 30.10.2008
Prüfört: <i>Testing location:</i>	TÜV Rheinland (Guangdong) Ltd. EMC Laboratory Guangzhou Auto Market, Yuan Gang Section of Guangshan Road, Guangzhou 510650, P. R. China	Listed test laboratory according to FCC rules section 2.948 for measuring devices under Parts 15
Prüfgrundlage: <i>Test specification:</i>	ANSI C63.4:2003 FCC Part 15: 20, Sep. 2007 Subpart B section 15.107, 15.109	
Prüfergebnis: <i>Test Result:</i>	Der Prüfgegenstand entspricht oben genannter Prüfgrundlage(n). <i>The test item passed the test specification(s).</i>	
Prüflaboratorium: <i>Testing Laboratory:</i>	TÜV Rheinland (Guangdong) Ltd.	
geprüft/ tested by:	kontrolliert/ reviewed by:	
22. Jan. 2009 Liangdong Xie/Project Manager 	22-Jan-2009 Ricky Liu/Project Manager 	
Datum Date	Name/Stellung Name/Position	Unterschrift Signature
Datum Date	Name/Stellung Name/Position	Unterschrift Signature
Sonstiges/ Other Aspects:		
Abkürzungen:	P(ass) = entspricht Prüfgrundlage F(ail) = entspricht nicht Prüfgrundlage N/A = nicht anwendbar N/T = nicht getestet	Abbreviations: P(ass) = passed F(ail) = failed N/A = not applicable N/T = not tested
Dieser Prüfbericht bezieht sich nur auf das o.g. Prüfmuster und darf ohne Genehmigung der Prüfstelle nicht auszugsweise vervielfältigt werden. Dieser Bericht berechtigt nicht zur Verwendung eines Prüfzeichens. <i>This test report relates to the a. m. test sample. Without permission of the test center this test report is not permitted to be duplicated in extracts. This test report does not entitle to carry any safety mark on this or similar products.</i>		

Prüfbericht - Nr.:
Test Report No.:

16015131 001

Seite 2 von 22
Page 2 of 22

TEST SUMMARY

5.1 CONDUCTED EMISSION FOR FCC PART 15 PER SECTION 15.107(A)

RESULT: Pass

5.2 RADIATED EMISSION FOR FCC PART 15 PER SECTION 15.109(A)

RESULT: Pass

Contents

1	GENERAL REMARKS.....	4
1.1	COMPLEMENTARY MATERIALS	4
2	TEST SITES.....	4
2.1	TEST FACILITIES	4
2.2	LIST OF TEST AND MEASUREMENT INSTRUMENTS	5
2.3	TRACE ABILITY.....	5
2.4	CALIBRATION	6
2.5	MEASUREMENT UNCERTAINTY.....	6
2.6	LOCATION OF ORIGINAL DATA.....	6
2.7	STATUS OF FACILITY USED FOR TESTING.....	6
3	GENERAL PRODUCT INFORMATION.....	7
3.1	PRODUCT FUNCTION AND INTENDED USE	7
3.2	RATINGS AND SYSTEM DETAILS	7
3.3	INDEPENDENT OPERATION MODES	7
3.4	SUBMITTED DOCUMENTS	7
4	TEST SET-UP AND OPERATION MODE	8
4.1	PRINCIPLE OF CONFIGURATION SELECTION.....	8
4.2	TEST OPERATION AND TEST SOFTWARE.....	8
4.3	SPECIAL ACCESSORIES AND AUXILIARY EQUIPMENT.....	8
4.4	COUNTERMEASURES TO ACHIEVE EMC COMPLIANCE	8
4.5	TEST SET-UP.....	9
5	TEST RESULTS EMISSION	11
5.1	CONDUCTED EMISSION FOR FCC PART 15 PER SECTION 15.107(A)	11
5.2	RADIATED EMISSION FOR FCC PART 15 PER SECTION 15.109(A).....	14
6	PHOTOGRAPHS OF THE TEST SET-UP.....	19
7	LIST OF TABLES.....	22
8	LIST OF PHOTOGRAPHS.....	22

Prüfbericht - Nr.:
Test Report No.:

16015131 001

Seite 4 von 22
Page 4 of 22

1 General Remarks

1.1 Complementary Materials

No appendix attached in this report.

2 Test Sites

2.1 Test Facilities

TÜV Rheinland (Guangdong) Ltd. EMC Laboratory

Guangzhou Auto Market, Yuan Gang Section of Guangshan Road
Guangzhou 510650

P. R. China

2.2 List of Test and Measurement Instruments

Table 1: List of Test and Measurement Equipment

Kind of Equipment	Type	Manufacturer	S/N	Calibrated until	Calibrated Interval
EMI Test Receiver	ESCI-3	Rohde & Schwarz	100216	24.Nov.2009	1 year
Spectrum Analyzer	FSP30	Rohde & Schwarz	100286	27.Aug.2009	1 year
Trilog-Broadband Antenna	VULB9168	SCHWARZBECK MESS-ELEKTRONIK	210	08.May.2009	2 year
Double-Ridged Waveguide Horn Antenna	HF906	Rohde & Schwarz	100385	18.Jul.2009	2 year
Double-Ridged Waveguide Horn Antenna	HF906	Rohde & Schwarz	100407	08.May.2009	2 year
Pre-amplifier	AFS42- 00101800- 25-S-42	MITEQ	1101599	31.Jul.2009	2 year
Band Reject Filter	BRM50702	Micro-Tronics	023	15.Feb.2010	2 year
Standard Gain Horn Antenna	3160-09	EMCO	21642	N/A	2 year
Standard Gain Horn Antenna	3160-09	EMCO	21645	N/A	2 year
Pre-amplifier	AFS33- 18002650- 30-8P-44	MITEQ	1108282	31.Jul.2009	2 year
3m Anechoic Chamber	N/A	Albatross Project GmbH	N/A	16.Apr.2010	2 year
EMI Test Receiver	ESCS30	Rohde & Schwarz	100316	27.Mar.2009	1 year
Two-Line V-Network	ESH3-Z5	Rohde & Schwarz	100308	27.Mar.2009	1 year
Pulse Limiter	ESH3-Z2	Rohde & Schwarz	100701	01.Mar.2009	1 year

2.3 Trace ability

All measurement equipment calibrations are traceable to NIST or where calibration is performed outside the United States, to equivalent nationally recognized standards organizations

Prüfbericht - Nr.:
Test Report No.:

16015131 001

Seite 6 von 22
Page 6 of 22

2.4 Calibration

Equipment requiring calibration is calibrated periodically by the manufacturer or according to manufacturer's specifications. Additionally all equipment is verified for proper performance on a regular basis using in house standards or comparisons.

2.5 Measurement Uncertainty

Uncertainty for conducted emissions measurements is ± 2.51 dB.

Uncertainty for radiated emissions measurements is ± 4.9 dB (30MHz-1GHz), ± 4.84 dB (>1GHz).

The reported expanded uncertainty is based on a standard uncertainty multiply by a coverage factor $k=2$, providing a level of confidence of approximately 95%.

2.6 Location of original data

The original copies of all test data taken during actual testing were attached at Appendix 1 of this report and delivered to the applicant. A copy has been retained in the TUV Rheinland (Guangzhou) file for certification follow-up purposes.

2.7 Status of facility used for testing

TÜV Rheinland (Guangdong) Ltd. EMC Laboratory; Guangzhou Auto Market, Yuan Gang Section of Guangshan Road, Guangzhou 510650, P. R. China is listed on the US Federal Communications Commission list of facilities approved to perform measurements, the register no. 833845

Prüfbericht - Nr.: 16015131 001
Test Report No.:

Seite 7 von 22
Page 7 of 22

3 General Product Information

The submitted sample WR-108DR is wireless microphones receiver operating within the frequency range of 174 MHz to 216 MHz.

RM200 (PROEL) is identical with WR-108DR except model name and brand name.

All the necessary tests were performed on model WR-108DR.

3.1 Product Function and Intended Use

For details, refer to User Manual.

3.2 Ratings and System Details

Frequency range	:	174 MHz – 216 MHz
Type of antenna	:	Integral
FCC ID:		H38WR-108DR-
Power supply	:	DC 12V to18V, 300mA Power by external AC/DC adaptor
Ports	:	DC input, audio output
Protection Class	:	III

Refer to the technical document and user manual for further information.

3.3 Independent Operation Modes

The basic operation modes are:

Receiving at a fixed frequency within the band 174 MHz to 216 MHz and not being changed by end user.

For further information refer to User Manual

3.4 Submitted Documents

Block Diagram
Circuit Diagram
PCB Layout
FCC Label
User Manual
Photo Document

Prüfbericht - Nr.:
Test Report No.:

16015131 001

Seite 8 von 22
Page 8 of 22

4 Test Set-up and Operation Mode

4.1 Principle of Configuration Selection

Emission: The equipment under test (EUT) was configured to measure its highest possible radiation level. The test modes were adapted accordingly in reference to the instructions for use.

4.2 Test Operation and Test Software

Refer to Test set-up in chapter 5.

4.3 Special Accessories and Auxiliary Equipment

The product has been tested together with the following linear AC/DC adaptor:

Adaptor:

Input : AC 120V, 60Hz
Output : DC 12V / 500mA
Protection class : II

4.4 Countermeasures to achieve EMC Compliance

The test sample, which has been tested, contained the noise suppression parts as described in the Constructional Data Form or the Technical document. No additional measures were employed to achieve compliance.

4.5 Test set-up

Diagram 1 of Configuration for Testing Radiated Emission below 1 GHz

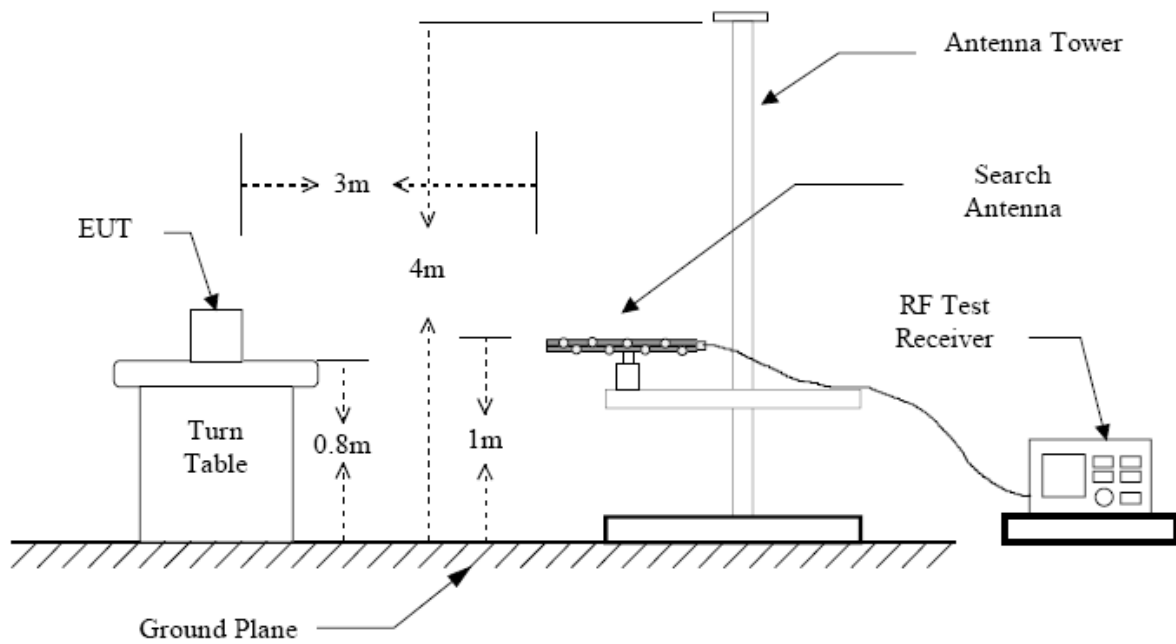

Diagram 2 of Configuration for Testing Radiated Emission above 1 GHz

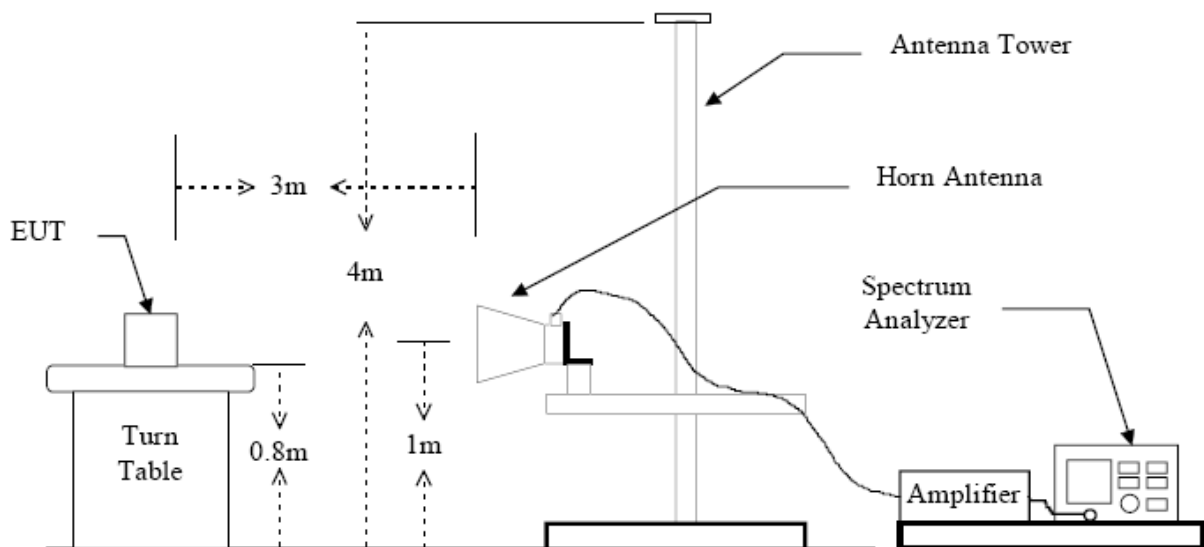
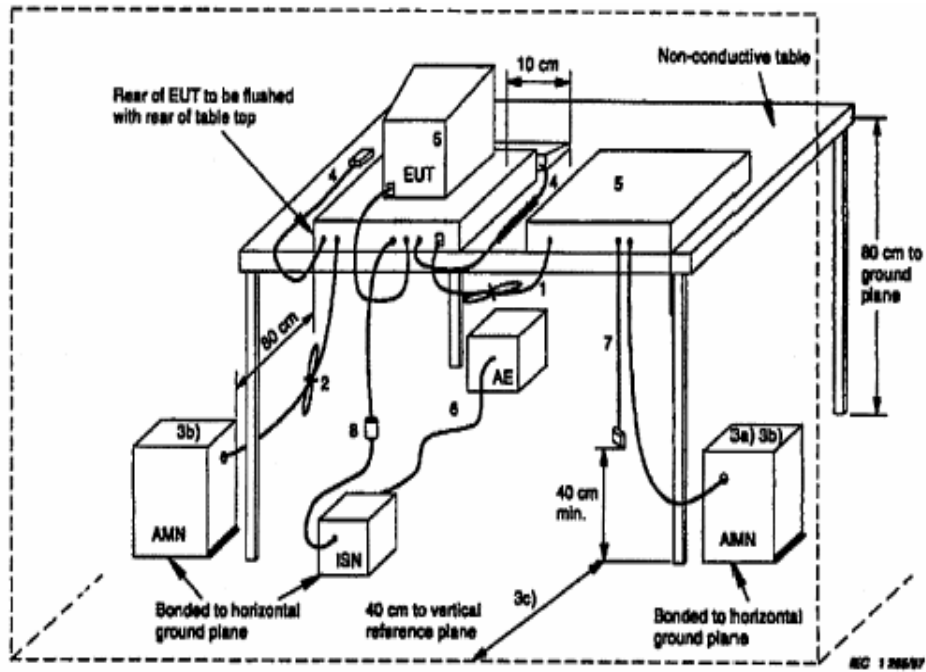

Diagram 3 of Equipment Configuration for Testing Conducted Emission



Prüfbericht - Nr.:
Test Report No.:

16015131 001

Seite 11 von 22
Page 11 of 22

5 Test Results EMISSION

5.1 Conducted Emission for FCC Part 15 Per Section 15.107(a)

RESULT:

Pass

Date of testing	:	31.Dec.2008
Test specification	:	FCC Part 15 Per Section 15.107(a)
Limits	:	FCC Part 15 Per Section 15.107(a)
Test procedure	:	Procedure specified in ANSI C63.4 were followed
Deviations from Standard Test procedures	:	None
Kind of test site	:	Shielded room
Operation mode	:	Receiving (powered by linear AC/DC adaptor)
Temperature	:	22°C
Humidity	:	50%

Test procedure:

1. Place the EUT as specified in ANSI C63.4 Clause 7.2.1
2. Plug the LISN to a correct power source (pay attention to: AC/DC, voltage, frequency).
4. Connect the EUT to LISN and choose N or L1 on the LISN.
5. Connect ESCS30 and LISN via a 50-ohm coaxial cable and a pulse limiter then begin exploratory measurement as specified in ANSI C63.4 Clause 7.2.3
6. Make final measurement as specified in ANSI C63.4 Clause 7.2.4
7. Switch to the other line on the LISN and repeat step 4 to 6.

If the result of the measurement with the Quasi Peak detector is below the Average limit, the measurement with Average Detector may be omitted.

The spectral diagrams in Appendix 1 display the exploratory measurement of un-weighted peak values and average values.

*) Disturbances other than those mentioned below are small or not detectable.

Prüfbericht - Nr.: 16015131 001
Test Report No.:

Seite 12 von 22
Page 12 of 22

Table 2: Disturbance Voltage on AC Mains (L line)

Final Measurement Detector 1

Frequency (MHz)	QuasiPeak (dB μ V)	Meas. Time (ms)	Bandwidth (kHz)	Line
0.345000	37.4	1000.000	9.000	L1
0.365000	35.9	1000.000	9.000	L1
0.880000	19.4	1000.000	9.000	L1
4.268980	11.5	1000.000	9.000	L1
7.862890	14.1	1000.000	9.000	L1
23.853620	15.3	1000.000	9.000	L1

(continuation of the "Final Measurement Detector 1" table from column 6 ...)

Frequency (MHz)	Corr. (dB)	Margin (dB)	Limit (dB μ V)	Comment
0.345000	10.2	21.7	59.1	
0.365000	10.2	22.7	58.6	
0.880000	10.2	36.6	56.0	
4.268980	10.4	44.5	56.0	
7.862890	10.7	45.9	60.0	
23.853620	11.8	44.7	60.0	

Final Measurement Detector 2

Frequency (MHz)	Average (dB μ V)	Meas. Time (ms)	Bandwidth (kHz)	Line
0.340000	20.9	1000.000	9.000	L1
0.390000	12.7	1000.000	9.000	L1
0.880000	9.9	1000.000	9.000	L1
4.928760	10.1	1000.000	9.000	L1
8.021410	11.1	1000.000	9.000	L1
29.948560	12.6	1000.000	9.000	L1

(continuation of the "Final Measurement Detector 2" table from column 6 ...)

Frequency (MHz)	Corr. (dB)	Margin (dB)	Limit (dB μ V)	Comment
0.340000	10.2	28.3	49.2	
0.390000	10.1	35.4	48.1	
0.880000	10.2	36.1	46.0	
4.928760	10.5	35.9	46.0	
8.021410	10.6	38.9	50.0	
29.948560	11.8	37.4	50.0	

Prüfbericht - Nr.:
Test Report No.:

16015131 001

Seite 13 von 22
Page 13 of 22

Table 3: Disturbance Voltage on AC Mains (N line)

Final Measurement Detector 1

Frequency (MHz)	QuasiPeak (dB μ V)	Meas. Time (ms)	Bandwidth (kHz)	Line
0.340000	37.5	1000.000	9.000	N
0.365000	35.7	1000.000	9.000	N
0.885000	17.8	1000.000	9.000	N
4.831360	11.7	1000.000	9.000	N
7.646210	13.9	1000.000	9.000	N
16.390240	14.2	1000.000	9.000	N

(continuation of the "Final Measurement Detector 1" table from column 6 ...)

Frequency (MHz)	Corr. (dB)	Margin (dB)	Limit (dB μ V)	Comment
0.340000	10.1	21.7	59.2	
0.365000	10.1	22.9	58.6	
0.885000	10.1	38.2	56.0	
4.831360	10.3	44.3	56.0	
7.646210	10.5	46.1	60.0	
16.390240	11.2	45.8	60.0	

Final Measurement Detector 2

Frequency (MHz)	Average (dB μ V)	Meas. Time (ms)	Bandwidth (kHz)	Line
0.345000	20.9	1000.000	9.000	N
0.365000	20.5	1000.000	9.000	N
0.900000	9.7	1000.000	9.000	N
4.928760	10.0	1000.000	9.000	N
7.989450	10.9	1000.000	9.000	N
24.334520	12.1	1000.000	9.000	N

(continuation of the "Final Measurement Detector 2" table from column 6 ...)

Frequency (MHz)	Corr. (dB)	Margin (dB)	Limit (dB μ V)	Comment
0.345000	10.1	28.2	49.1	
0.365000	10.1	28.1	48.6	
0.900000	10.1	36.3	46.0	
4.928760	10.3	36.0	46.0	
7.989450	10.5	39.1	50.0	
24.334520	11.5	37.9	50.0	

Prüfbericht - Nr.:
Test Report No.:

16015131 001

Seite 14 von 22
Page 14 of 22

5.2 Radiated Emission for FCC Part 15 Per Section 15.109(a)

RESULT:

Pass

Date of testing	:	12.Dec.2008
Test specification	:	FCC Part 15 Per Section 15.109(a)
Limits	:	FCC Part 15 Per Section 15.109(a)
Test procedure	:	Procedure specified in ANSI C63.4 were followed
Deviations from Standard Test procedures		
	:	None
Kind of test site	:	3m Semi-anechoic chamber
Operation mode	:	Receiving at high and low channels
Temperature	:	22°C
Humidity	:	50%

Test procedure:

1. The EUT was turned on and placed on the top of a rotatable table 0.8 meters above the ground with 3-orthogonal XYZ direction and be kept close enough to the measurement receiving antenna (especially for the measurement frequency range above 1 GHz). The table was then rotated 360 degrees to detect the suspected emission frequency points. The position of the worst radiation case with both horizontal and vertical receiving antenna polarization was then recorded together with the suspected emission frequency points above-mentioned.
2. The EUT was then set 3 meters away from the receiving antenna, which was mounted on a variable-height antenna tower.
3. For each suspected emission frequency point recorded in step 1, the EUT was arranged to its worst case that the antenna was tuned to heights from 1 meter to 4 meters and the rotatable table was turned from 0 degrees to 360 degrees to read the maximum emission.

Prüfbericht - Nr.:
Test Report No.:

16015131 001

Seite 15 von 22
Page 15 of 22

Table 4: Final measurements of Radiated Emission (EUT was set to lowest channel)

(30MHz to 1000MHz)

Limit and Margin

Frequency (MHz)	QuasiPeak (dB μ V/m)	Corr. (dB)	Margin (dB)	Limit (dB μ V/m)	Polarity
38.600000	10.5	14.4	29.5	40.0	V
38.600000	10.4	14.4	29.6	40.0	V
163.350000	21.1	12.9	22.4	43.5	V
467.250000	17.5	21.1	28.5	46.0	V
697.950000	23.3	25.7	22.7	46.0	V

Limit and Margin

Frequency (MHz)	QuasiPeak (dB μ V/m)	Corr. (dB)	Margin (dB)	Limit (dB μ V/m)	Polarity
217.800000	22.1	13.2	23.9	46.0	H
272.400000	22.9	15.4	23.1	46.0	H
326.800000	26.8	17.2	19.2	46.0	H
460.550000	27.8	20.8	18.2	46.0	H

(1GHz to 2GHz)

Limit and Margin PK

Frequency (MHz)	MaxPeak (dB μ V/m)	Margin (dB)	Limit (dB μ V/m)	Polarity	Corr. (dB)
1143.500000	28.2	45.8	74.0	V	-16.8
1307.000000	29.9	44.1	74.0	V	-16.0
1470.000000	30.4	43.6	74.0	V	-15.7
1906.500000	34.5	39.5	74.0	V	-13.4

Limit and Margin AV

Frequency (MHz)	Average (dB μ V/m)	Margin (dB)	Limit (dB μ V/m)	Polarity	Corr. (dB)
1143.500000	15.8	38.2	54.0	V	-16.8
1307.000000	17.3	36.7	54.0	V	-16.0
1470.000000	17.3	36.7	54.0	V	-15.7
1906.500000	25.5	28.5	54.0	V	-13.4

Limit and Margin PK

Frequency (MHz)	MaxPeak (dB μ V/m)	Margin (dB)	Limit (dB μ V/m)	Polarity	Corr. (dB)
1143.500000	28.3	45.7	74.0	H	-16.8
1307.000000	29.6	44.4	74.0	H	-16.0
1470.000000	30.1	43.9	74.0	H	-15.7
1797.000000	31.0	43.0	74.0	H	-14.1

Limit and Margin AV

Frequency (MHz)	Average (dB μ V/m)	Margin (dB)	Limit (dB μ V/m)	Polarity	Corr. (dB)
1143.500000	15.9	38.1	54.0	H	-16.8
1307.000000	17.3	36.7	54.0	H	-16.0
1470.000000	17.3	36.7	54.0	H	-15.7
1797.000000	18.8	35.2	54.0	H	-14.1

Prüfbericht - Nr.:
Test Report No.:

16015131 001

Seite 16 von 22
Page 16 of 22

Table 5: Final measurements of Radiated Emission (EUT was set to mid channel)

(30MHz to 1000MHz)

Limit and Margin

Frequency (MHz)	QuasiPeak (dB μ V/m)	Corr. (dB)	Margin (dB)	Limit (dB μ V/m)	Polarity
53.500000	12.5	12.3	27.5	40.0	V
136.900000	15.8	11.1	27.7	43.5	V
205.300000	30.5	12.7	13.0	43.5	V
959.850000	26.6	29.2	19.4	46.0	V

Limit and Margin

Frequency (MHz)	QuasiPeak (dB μ V/m)	Corr. (dB)	Margin (dB)	Limit (dB μ V/m)	Polarity
39.100000	10.6	14.4	29.4	40.0	H
136.800000	19.5	11.1	24.0	43.5	H
205.300000	39.8	12.7	3.7	43.5	H
613.800000	21.9	24.4	24.1	46.0	H

(1GHz to 2GHz)

Limit and Margin PK

Frequency (MHz)	MaxPeak (dB μ V/m)	Margin (dB)	Limit (dB μ V/m)	Polarity	Corr. (dB)
1711.000000	34.5	39.5	74.0	V	-14.4
1779.000000	34.4	39.6	74.0	V	-14.0
1847.500000	34.9	39.1	74.0	V	-13.7
1916.500000	34.0	40.0	74.0	V	-13.3

Limit and Margin AV

Frequency (MHz)	Average (dB μ V/m)	Margin (dB)	Limit (dB μ V/m)	Polarity	Corr. (dB)
1711.000000	27.0	27.0	54.0	V	-14.4
1779.000000	26.5	27.5	54.0	V	-14.0
1847.500000	27.1	26.9	54.0	V	-13.7
1916.500000	25.8	28.2	54.0	V	-13.3

Limit and Margin PK

Frequency (MHz)	MaxPeak (dB μ V/m)	Margin (dB)	Limit (dB μ V/m)	Polarity	Corr. (dB)
1232.000000	29.7	44.3	74.0	H	-16.5
1437.000000	30.0	44.0	74.0	H	-15.6
1642.500000	30.9	43.1	74.0	H	-14.8
1847.500000	31.3	42.7	74.0	H	-13.7

Limit and Margin AV

Frequency (MHz)	Average (dB μ V/m)	Margin (dB)	Limit (dB μ V/m)	Polarity	Corr. (dB)
1232.000000	16.4	37.6	54.0	H	-16.5
1437.000000	17.6	36.4	54.0	H	-15.6
1642.500000	18.3	35.7	54.0	H	-14.8
1847.500000	18.9	35.1	54.0	H	-13.7

Prüfbericht - Nr.:

16015131 001

Seite 17 von 22

Test Report No.:

Page 17 of 22

Table 6: Final measurements of Radiated Emission (EUT was set to highest channel)

(30MHz to 1000MHz)

Limit and Margin

Frequency (MHz)	QuasiPeak (dB μ V/m)	Corr. (dB)	Margin (dB)	Limit (dB μ V/m)	Polarity
53.500000	13.5	12.3	26.5	40.0	V
136.350000	19.5	11.1	24.0	43.5	V
204.500000	30.1	12.7	13.4	43.5	V
693.350000	23.1	25.6	22.9	46.0	V

Limit and Margin

Frequency (MHz)	QuasiPeak (dB μ V/m)	Corr. (dB)	Margin (dB)	Limit (dB μ V/m)	Polarity
43.600000	10.6	13.9	29.4	40.0	H
66.250000	7.5	10.8	32.5	40.0	H
204.500000	36.0	12.7	7.5	43.5	H
759.100000	24.0	26.4	22.0	46.0	H

(1GHz to 2GHz)

Limit and Margin PK

Frequency (MHz)	MaxPeak (dB μ V/m)	Margin (dB)	Limit (dB μ V/m)	Polarity	Corr. (dB)
1636.000000	32.2	41.8	74.0	V	-14.8
1772.500000	34.6	39.4	74.0	V	-14.0
1840.500000	33.1	40.9	74.0	V	-13.8
1908.500000	32.5	41.5	74.0	V	-13.3

Limit and Margin AV

Frequency (MHz)	Average (dB μ V/m)	Margin (dB)	Limit (dB μ V/m)	Polarity	Corr. (dB)
1636.000000	25.3	28.7	54.0	V	-14.8
1772.500000	28.2	25.8	54.0	V	-14.0
1840.500000	27.9	26.1	54.0	V	-13.8
1908.500000	27.3	26.7	54.0	V	-13.3

Limit and Margin PK

Frequency (MHz)	MaxPeak (dB μ V/m)	Margin (dB)	Limit (dB μ V/m)	Polarity	Corr. (dB)
1227.000000	29.4	44.6	74.0	H	-16.5
1431.500000	29.7	44.3	74.0	H	-15.6
1636.000000	30.5	43.5	74.0	H	-14.8

Limit and Margin AV

Frequency (MHz)	Average (dB μ V/m)	Margin (dB)	Limit (dB μ V/m)	Polarity	Corr. (dB)
1227.000000	16.4	37.6	54.0	H	-16.5
1431.500000	17.4	36.6	54.0	H	-15.6
1636.000000	18.3	35.7	54.0	H	-14.8

Prüfbericht - Nr.:

16015131 001

Seite 18 von 22

Test Report No.:

Page 18 of 22

Disturbances other than those mentioned above are far below the limit or not detectable.

The final measurement for frequencies below 1000MHz is performed with Quasi Peak detector; the final measurement for frequencies above 1000MHz is performed with Average and Peak detector.

The limit on peak radio frequency emissions is 20 dB above the maximum permitted average emission limit applicable to the equipment under test.

The resolution bandwidth and video bandwidth of test receiver/spectrum analyzer is 120 kHz at frequency below 1GHz.

The resolution bandwidth of test receiver/spectrum analyzer is 1 MHz at frequency above 1GHz.

Prüfbericht - Nr.:
Test Report No.:

16015131 001

Seite 19 von 22
Page 19 of 22

6 Photographs of the Test Set-Up

Photograph 1: Set up for Conducted Emission on AC Mains

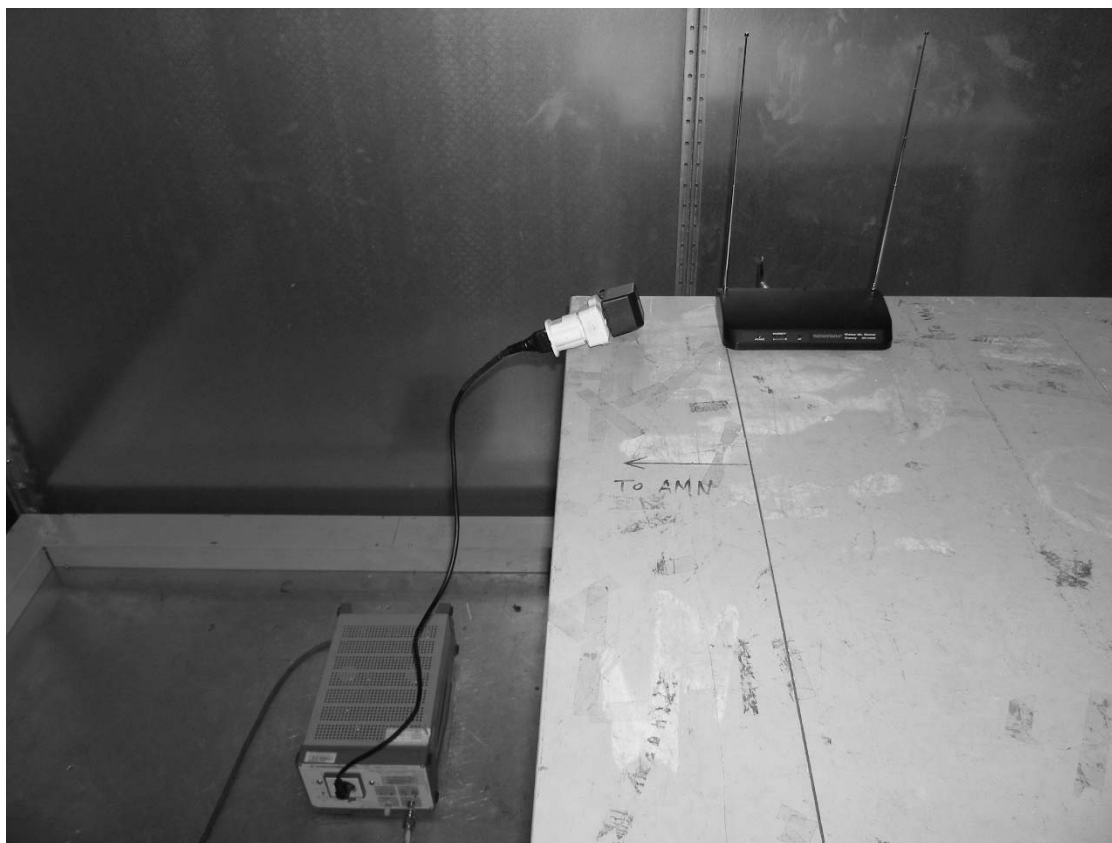

Prüfbericht - Nr.:
Test Report No.:

16015131 001

Seite 20 von 22
Page 20 of 22

Photograph 2: Set-up for Radiation Measurement Below 1GHz



Prüfbericht - Nr.:
Test Report No.:

16015131 001

Seite 21 von 22
Page 21 of 22

Photograph 3: Set-up for Radiation Measurement Above 1GHz



7 List of Tables

Table 1: List of Test and Measurement Equipment.....	5
Table 2: Disturbance Voltage on AC Mains (L line)	12
Table 3: Disturbance Voltage on AC Mains (N line).....	13
Table 4: Final measurements of Radiated Emission (EUT was set to lowest channel).....	15
Table 5: Final measurements of Radiated Emission (EUT was set to mid channel)	16
Table 6: Final measurements of Radiated Emission (EUT was set to highest channel).....	17

8 List of Photographs

Photograph 1: Set up for Conducted Emission on AC Mains	19
Photograph 2: Set-up for Radiation Measurement Below 1GHz	20
Photograph 3: Set-up for Radiation Measurement Above 1GHz	21