

Produkte
Products

Prüfbericht - Nr.: 17024817 001 <i>Test Report No.:</i>		Seite 1 von 31 <i>Page 1 of 31</i>	
Auftraggeber: <i>Client:</i>		Seikaku Technical Group Limited Offshor Chambers, P.O. Box 217, Apia, Samoa	
Gegenstand der Prüfung: <i>Test item:</i>		Wireless Microphone	
Bezeichnung: <i>Identification:</i>		WL-200P	Serien-Nr.: n.a. <i>Serial No.:</i>
Wareneingangs-Nr.: <i>Receipt No.:</i>		163089214	Eingangsdatum: 2012-02-13 <i>Date of receipt:</i>
Zustand des Prüfgegenstandes bei Anlieferung: Condition of test item at delivery:		The sample is OK for testing and not damaged	
Prüfört: <i>Testing location:</i>		<ul style="list-style-type: none"> • TÜV Rheinland (Guangdong) Ltd. EMC Laboratory (FCC Registration No.: 833845) (Industry Canada Test Site No.: 2932C-1) • Shenzhen Huatongwei International Inspection Co., Ltd (FCC Registration No.: 662850) (Industry Canada Test Site No.: 5377A-1) 	
Prüfgrundlage: <i>Test specification:</i>		FCC Title 47 CFR Part 74 Subpart H	
Prüfergebnis: <i>Test Result:</i>		Der Prüfgegenstand entspricht oben genannter Prüfgrundlage(n). The test item passed the test specification(s).	
Prüflaboratorium: <i>Testing Laboratory:</i>		TÜV Rheinland (Shenzhen) Co., Ltd.	
geprüft/ tested by:		kontrolliert/ reviewed by:	
			
2012-07-05	Sam Lin/ Project Manager	2012-07-06	Shawn Peng/ Technical Certifier
<i>Datum</i> <i>Date</i>	<i>Name/Stellung</i> <i>Name/Position</i>	<i>Datum</i> <i>Date</i>	<i>Name/Stellung</i> <i>Name/Position</i>
	<i>Unterschrift</i> <i>Signature</i>		<i>Unterschrift</i> <i>Signature</i>
Sonstiges/ Other Aspects:			
Abkürzungen:		Abbreviations:	
P(ass) = entspricht Prüfgrundlage		P(ass) = passed	
F(ail) = entspricht nicht Prüfgrundlage		F(ail) = failed	
N/A = nicht anwendbar		N/A = not applicable	
NIT = nicht getestet		NIT = not tested	
<p>Dieser Prüfbericht bezieht sich nur auf das o.g. Prüfmuster und darf ohne Genehmigung der Prüfstelle nicht auszugsweise vervielfältigt werden. Dieser Bericht berechtigt nicht zur Verwendung eines Prüfzeichens.</p> <p><i>This test report relates to the a. m. test item. Without permission of the test center this test report is not permitted to be duplicated in extracts. This test report does not entitle to carry any safety mark on this or similar products.</i></p>			

TEST SUMMARY

5.1.1 TRANSMITTER OUTPUT POWER*RESULT: Passed***5.1.2 SPURIOUS RADIATION EMISSIONS***RESULT: Passed***5.1.3 OPERATING BANDWIDTH AND EMISSIONS MASK***RESULT: Passed***5.1.4 FREQUENCY TOLERANCE***RESULT: Passed***5.1.5 MODULATION CHARACTERISTICS***RESULT: Passed***6.1.1 ELECTROMAGNETIC FIELDS***RESULT: Passed*

Contents

1.	GENERAL REMARKS	4
1.1	COMPLEMENTARY MATERIALS	4
2.	TEST SITES	4
2.1	TEST FACILITIES	4
2.2	LIST OF TEST AND MEASUREMENT INSTRUMENTS.....	5
2.3	TRACEABILITY	6
2.4	CALIBRATION	6
2.5	MEASUREMENT UNCERTAINTY.....	6
2.6	LOCATION OF ORIGINAL DATA.....	6
2.7	STATUS OF FACILITY USED FOR TESTING.....	6
3.	GENERAL PRODUCT INFORMATION	7
3.1	PRODUCT FUNCTION AND INTENDED USE.....	7
3.2	RATINGS AND SYSTEM DETAILS	7
3.3	INDEPENDENT OPERATION MODES	8
3.4	NOISE GENERATING AND NOISE SUPPRESSING PARTS	8
3.5	SUBMITTED DOCUMENTS	9
4.	TEST SET-UP AND OPERATION MODES	9
4.1	PRINCIPLE OF CONFIGURATION SELECTION.....	9
4.2	TEST OPERATION AND TEST SOFTWARE	9
4.3	SPECIAL ACCESSORIES AND AUXILIARY EQUIPMENT	9
4.4	COUNTERMEASURES TO ACHIEVE EMC COMPLIANCE.....	10
4.5	TEST SETUP DIAGRAM	10
5.	TEST RESULTS	12
5.1	TRANSMITTER REQUIREMENT & TEST SUITES	12
5.1.1	<i>Transmitter Output Power</i>	<i>12</i>
5.1.2	<i>Spurious Radiation Emissions</i>	<i>15</i>
5.1.3	<i>Operating Bandwidth and Emissions Mask</i>	<i>18</i>
5.1.4	<i>Frequency Tolerance</i>	<i>24</i>
5.1.5	<i>Modulation Characteristics.....</i>	<i>25</i>
6.	SAFETY HUMAN EXPOSURE	29
6.1	RADIO FREQUENCY EXPOSURE COMPLIANCE.....	29
6.1.1	<i>Electromagnetic Fields.....</i>	<i>29</i>
7.	PHOTOGRAPHS OF THE TEST SET-UP	30
8.	LIST OF TABLES	31
9.	LIST OF PHOTOGRAPHS	31

1. General Remarks

1.1 Complementary Materials

None.

2. Test Sites

2.1 Test Facilities

TÜV Rheinland (Guangdong) Ltd. EMC Laboratory
(FCC Registration No.: 833845 & Test Site Industry Canada No.: 2932C-1)

Guangzhou Auto Market, Yuan Gang Section, Guangshan Road, Guangzhou, P.R. China

Shenzhen Huatongwei International Inspection Co., Ltd
(FCC Registration No.: 663850 & Test Site Industry Canada No.: 5377A-1)

Keji Nan No. 12 Road, Hi-tech Park, Shenzhen, China

The tests at the test site have been conducted under the supervision of a TÜV engineer.

2.2 List of Test and Measurement Instruments

Table 1: List of Test and Measurement Equipment

Kind of Equipment	Manufacturer	Type No.	Serial No.	Calibrated until
Spurious emissions (TÜV Rheinland (Guangdong) Ltd. EMC Laboratory)				
EMI Test Receiver	Rohde & Schwarz	ESCI-3	100216	2013-03-12
Spectrum Analyzer	Rohde & Schwarz	FSP30	100286	2013-03-12
Trilog-Broadband Antenna	SCHWARZBEC K	VULB9168	209	2013-03-12
Double-Ridged Waveguide Horn Antenna	Rohde & Schwarz	HF906	100385	2012-08-23
Pre-amplifier	MITEQ	AFS42-00101800-25-S-42	1101599	2012-07-30
Radio Spectrum Test (TÜV Rheinland (Guangdong) Ltd. EMC Laboratory)				
Spectrum Analyzer	Agilent	E4404B	MY41440753	2013-03-12
Climatic Chamber	GZ-ESPEC	EL-04KA	6107116	2013-03-12
Modulation Characteristics Test (Shenzhen Huatongwei International Inspection Co., Ltd. EMC Laboratory)				
RF Communication Test Set	HP	8920A	3813A10206	2012-10-23

2.3 Traceability

All measurement equipment calibrations are traceable to NIST or where calibration is performed outside the United States, to equivalent nationally recognized standards organizations.

2.4 Calibration

Equipment requiring calibration is calibrated periodically by the manufacturer or according to manufacturer's specifications. Additionally all equipment is verified for proper performance on a regular basis using in house standards or comparisons.

2.5 Measurement Uncertainty

The estimated combined standard uncertainty for radiated emissions and conducted emissions measurements as below table,

Items		Extended Uncertainty
RE (30-1000MHz)	Field strength (dBuV/m)	U=4.94dB, k=2, $\sigma=95\%$
RE (above 1000MHz)	Field strength (dBuV/m)	U=4.88dB, k=2, $\sigma=95\%$

2.6 Location of Original Data

The original copies of all test data taken during actual testing were attached at Appendix1 of this report and delivered to the applicant. A copy has been retained in the TÜV Rheinland (Shenzhen) file for certification follow-up purposes.

2.7 Status of Facility Used for Testing

The TÜV Rheinland (Guangdong) Ltd. EMC Laboratory & Shenzhen Huatongwei International Inspection Co., Ltd facility located at Guangzhou Auto Market, Yuan Gang Section, Guangshan Road, Guangzhou, P.R. China & Keji Nan No. 12 Road, Hi-tech Park, Shenzhen, China are listed on the US Federal Communications Commission list of facilities approved to perform measurements.

3. General Product Information

3.1 Product Function and Intended Use

The EUT is transmitter in wireless microphone system. It can be operated in 175 ~ 186MHz frequency range.

Model WL-200P is the delicately designed VHF, PLL synthesized system, with antenna built inside.

For details refer to the User Manual and Circuit Diagram.

3.2 Ratings and System Details

Table 2: Rating of EUT

Kind of Equipment:	Wireless Microphone
Type Designation:	WL-200P
FCC ID	H38WL-200P

Table 3: Technical Specification of EUT

Technical Specification	Value
Operating Frequency:	175-186MHz
Operation Voltage:	DC 3V (via 'AA' ALKALINE battery)
Rated RF output power:	10mW
Modulation:	FM (F3E)
Rated Frequency Deviation:	9kHz @ 1000Hz
Antenna Type:	Integrated Antenna
Number of Antenna:	1
Number of Channels:	16

Table 4: List of Operating Channel

Item	WL-200P
Channel	Frequency (MHz)
CH 0	175.125
CH 1	175.375
CH 2	175.775
CH 3	175.975
CH 4	176.175
CH 5	176.525
CH 6	176.975
CH 7	177.925
CH 8	178.125
CH 9	178.925
CH A	180.725
CH B	181.525
CH C	182.025
CH D	183.225
CH E	184.525
CH F	185.125

3.3 Independent Operation Modes

The basic operation modes are:

- A. On, Transmitting
 - 1. Low channel
 - 2. Middle channel
 - 3. High channel
- B. Off

3.4 Noise Generating and Noise Suppressing Parts

Refer to the Circuit Diagram.

3.5 Submitted Documents

- Bill of Material
- PCB Layout
- Photo Document
- Circuit Diagram
- Instruction Manual
- Rating Label

4. Test Set-up and Operation Modes

4.1 Principle of Configuration Selection

The equipment under test (EUT) was configured to measure its maximum power level. The test modes were adapted accordingly in reference to the instructions for use.

4.2 Test Operation and Test Software

Test operation refers to test setup in chapter 5.

All test items have been performed according to FCC Title 47 CFR Part 74 Subpart H and TIA-603-C-2004.

Table 5: List of Test Channel

Test Channel	WL-200P
Low Channel	175.125 (CH 0)
Middle Channel	180.725 (CH A)
High Channel	185.125 (CH F)

4.3 Special Accessories and Auxiliary Equipment

None.

4.4 Countermeasures to achieve EMC Compliance

The test sample which has been tested contained the noise suppression parts as described in the Constructional Data Form or the Technical Construction File. No additional measures were employed to achieve compliance.

4.5 Test Setup Diagram

Diagram of Measurement Configuration for Radiation Test

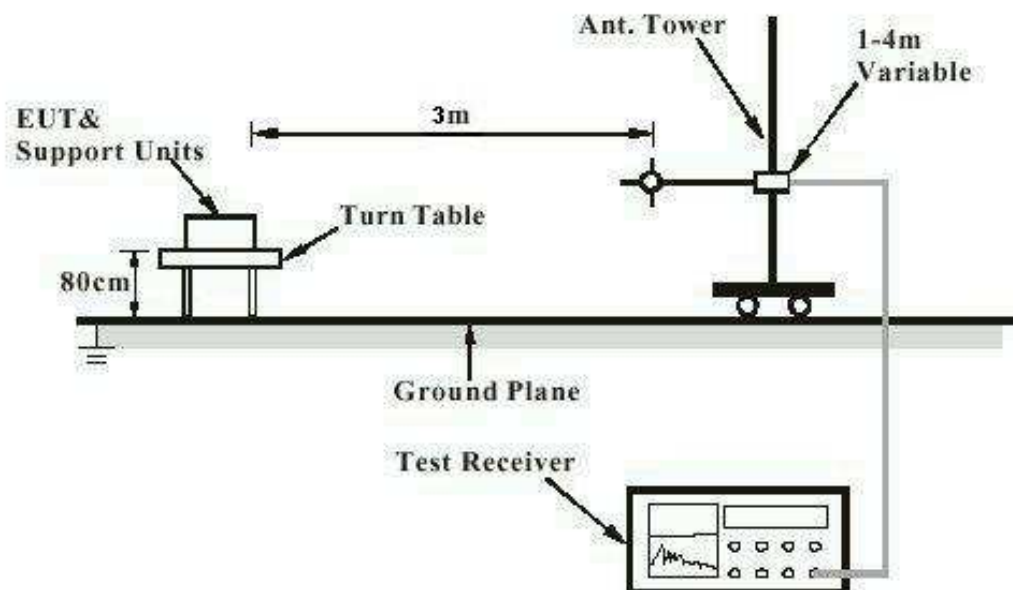
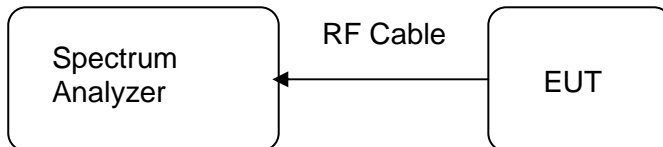
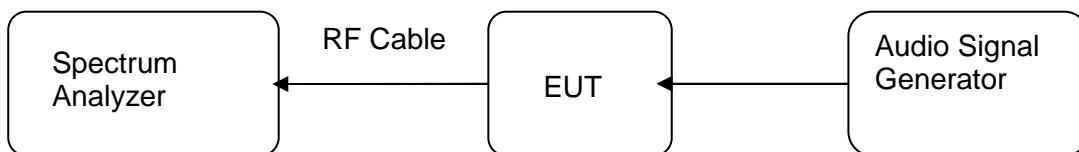

Diagram of Measurement Equipment Configuration for Transmitter Measurement

Output power:



Operating bandwidth and Emissions mask:



Frequency Tolerance:

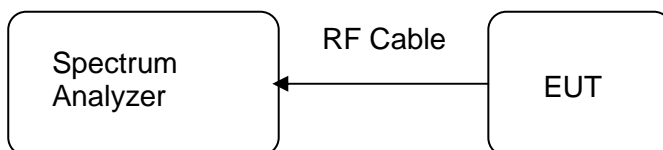

Modulation Characteristics:

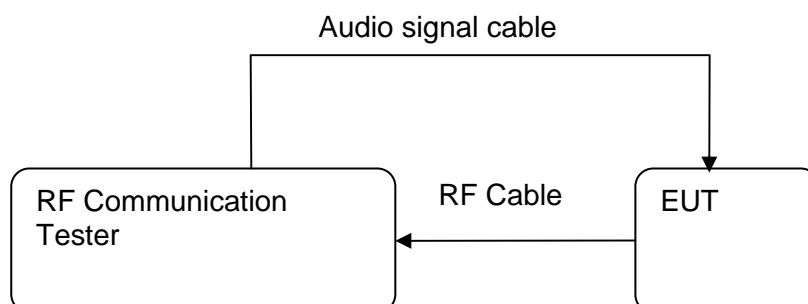

5. Test Results

5.1 Transmitter Requirement & Test Suites

5.1.1 Transmitter Output Power

RESULT:
Passed

Test date : 2012-03-16 to 2012-05-20
 Test standard : FCC Part 74.861(e)(1)
 Limit : 50mW
 Kind of test site : Shielded room

Test setup

Test Channel : Low/ Middle/ High
 Operation Mode : A
 Modulation : unmodulated carrier
 Ambient temperature : 23°C
 Relative humidity : 50%
 Atmospheric pressure : 101.0 kPa

Table 6: Test results of Transmitter Output Power

Channel	Channel Frequency (MHz)	Peak Output Power		Limit (mW)
		(dBm)	(mW)	
Low Channel	175.125	8.676	7.37	50
Middle Channel	180.725	9.594	9.11	50
High Channel	185.125	8.753	7.50	50

Test Graph of Peak Output Power Low Channel

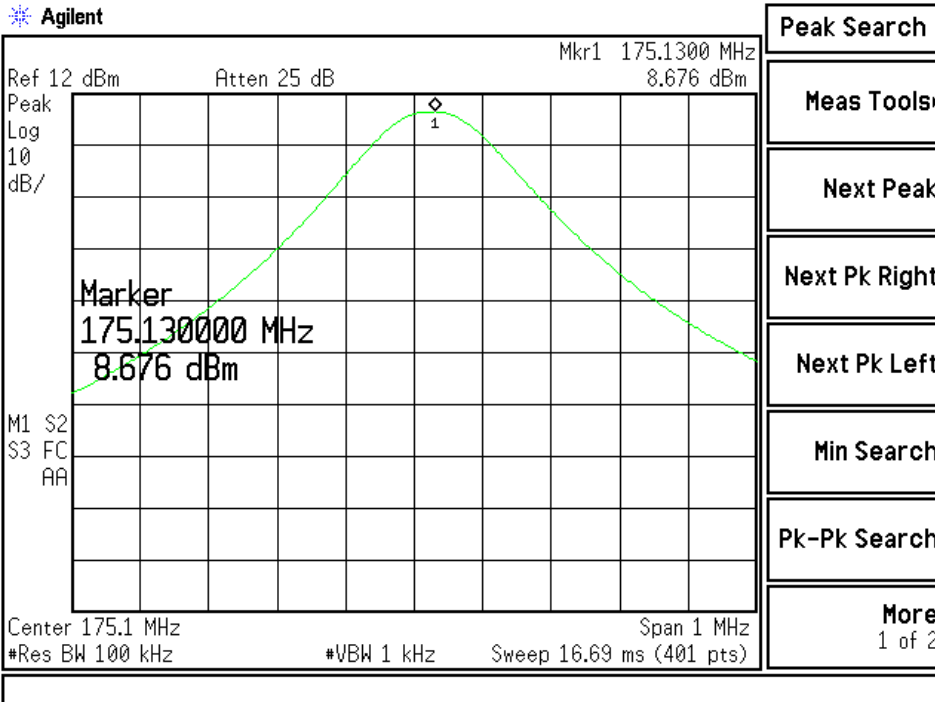

Middle Channel

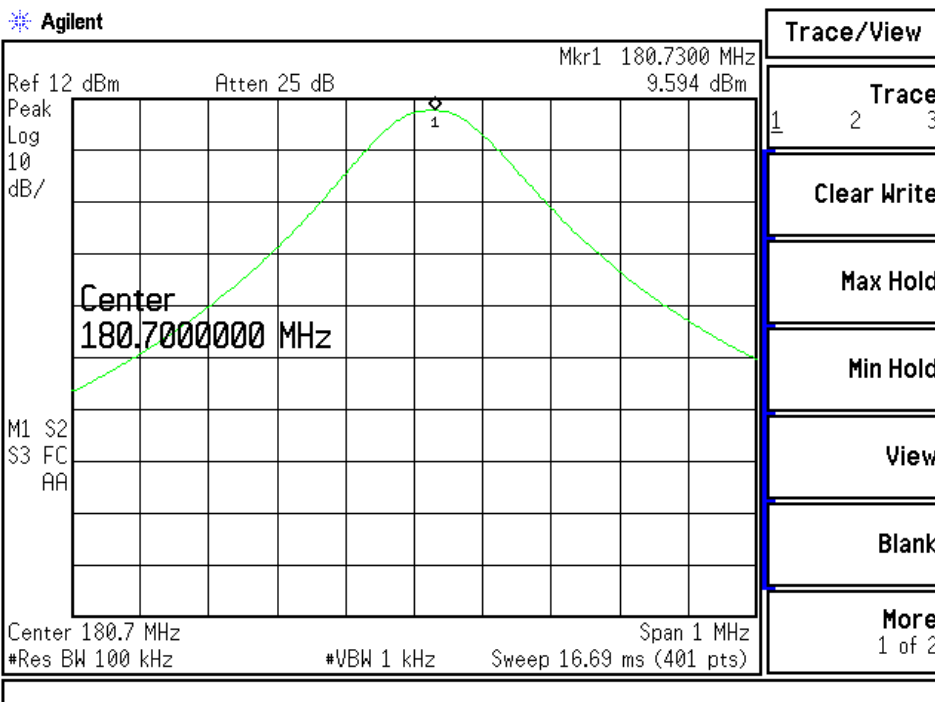

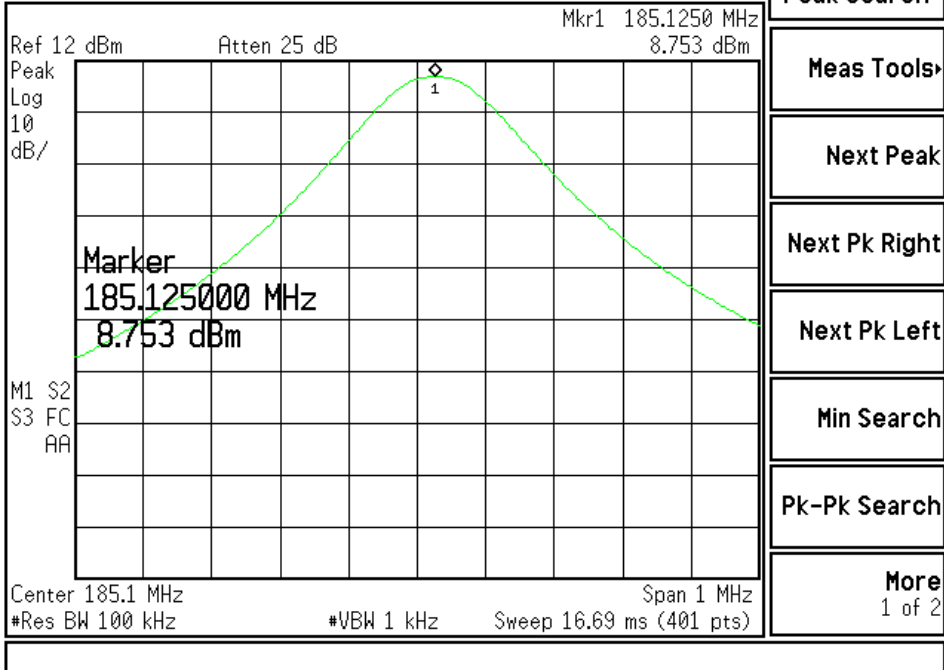
High Channel
 **Agilent**

5.1.2 Spurious Radiation Emissions

RESULT:
Passed

Date of testing : 2012-03-16 to 2012-05-20
 Test standard : FCC Part 74.861(e)(6)(iii)
 Limit : On any frequency removed from the operating frequency by more than 250 percent of the authorized bandwidth: at least $43+10\log_{10}(\text{output power in watts})$ dB
 Frequency range : 30MHz ~ 5GHz
 Kind of test site : 3m Seim-Anechoic Chamber

Test setup

Test Channel : Low/ Middle/ High
 Operation Mode : A
 Modulation : Modulation
 Ambient temperature : 24°C
 Relative humidity : 52%
 Atmospheric pressure : 101.0 kPa

Table 7: Limit Calculation

Channel	Output Power (mW)	Formula	Attenuation (dB)	Absolute Limit (dBm)
Low Channel	7.37	$43+10\log_{10}(P)$ dB	21.7	-13
Mid Channel	9.11	$43+10\log_{10}(P)$ dB	22.6	-13
High Channel	7.50	$43+10\log_{10}(P)$ dB	21.8	-13

Table 8: Test results of Spurious Radiation Emissions

Low Channel				
Frequency (MHz)	Polarization of Antenna (V/H)	Result (dBm)	Limit (dBm)	Margin (dB)
47.34	H	-66.6	-13	-53.6
156.46	H	-68.6	-13	-55.6
350.22	H	-56.4	-13	-43.4
512.33	H	-62.7	-13	-49.7
723.91	H	-57.1	-13	-44.1
854.14	H	-55.6	-13	-42.6
44.30	V	-74.2	-13	-61.2
148.00	V	-68.9	-13	-55.9
350.20	V	-63.3	-13	-50.3
525.45	V	-64.0	-13	-51.0
758.85	V	-73.4	-13	-60.4

850.25	V	-60.8	-13	-47.8
4028.00	V	-53.1	-13	-40.1
4203.00	V	-51.6	-13	-38.6
4729.00	V	-53.0	-13	-40.0
4904.00	V	-52.2	-13	-39.2
1238.00	H	-64.8	-13	-51.8
4028.00	H	-52.5	-13	-39.5
4378.00	H	-54.2	-13	-41.2
4771.00	H	-53.7	-13	-40.7

Middle Channel

Frequency (MHz)	Polarization of Antenna (V/H)	Result (dBm)	Limit (dBm)	Margin (dB)
44.43	H	-66.4	-13	-53.4
137.43	H	-68.9	-13	-55.9
356.30	H	-41.9	-13	-28.9
534.35	H	-38.1	-13	-25.1
746.47	H	-59.1	-13	-46.1
890.75	H	-55.4	-13	-42.4
43.60	V	-73.1	-13	-60.1
141.20	V	-69.1	-13	-56.1
356.30	V	-48.1	-13	-35.1
534.40	V	-33.1	-13	-20.1
890.65	V	-54.8	-13	-41.8
4097.00	V	-52.6	-13	-39.6
4275.00	V	-51.5	-13	-38.5
4632.00	V	-52.0	-13	-39.0
4810.00	V	-49.3	-13	-36.3
1184.00	H	-64.8	-13	-51.8
2311.00	H	-61.1	-13	-48.1
4245.00	H	-53.8	-13	-40.8
4467.00	H	-54.1	-13	-41.1

High Channel				
Frequency (MHz)	Polarization of Antenna (V/H)	Result (dBm)	Limit (dBm)	Margin (dB)
39.20	H	-66.2	-13	-53.2
59.60	H	-63.6	-13	-50.6
141.30	H	-63.4	-13	-50.4
370.25	H	-47.5	-13	-34.5
621.95	H	-78.5	-13	-65.5
857.75	H	-53.4	-13	-40.4
47.00	V	-74.0	-13	-61.0
144.20	V	-69.3	-13	-56.3
220.85	V	-69.0	-13	-56.0
370.20	V	-55.4	-13	-42.4
624.60	V	-55.8	-13	-42.8
928.35	V	-58.5	-13	-45.5
4073.00	V	-51.1	-13	-38.1
4258.00	V	-46.8	-13	-33.8
4814.00	V	-47.8	-13	-34.8
4999.00	V	-49.6	-13	-36.6
1531.00	H	-61.8	-13	-48.8
3826.00	H	-54.9	-13	-41.9
4259.00	H	-52.6	-13	-39.6
4599.00	H	-55.0	-13	-42.0

5.1.3 Operating Bandwidth and Emissions Mask

RESULT:
Passed

Date of testing : 2012-03-16 to 2012-05-20
 Test standard : FCC Part 74.861(e)(3) & (5) , (6)(i)(ii)
 Limit : Part 74.861(e)(3), Maximum deviation of ± 75 kHz
 Part 74.861(e)(5), operating bandwidth shall not exceed 200kHz
 Part 74.861(e)(6)(i) & (ii)
 Kind of test site : Shield room

Test setup

Test Channel : Low/ Middle/ High
 Operation mode : A
 Ambient temperature : 24°C
 Relative humidity : 52%
 Atmospheric pressure : 101.0 kPa

Table 9: Test results of Maximum Deviation

Channel	Frequency (MHz)	Result (kHz)	Limit (kHz)
Low	175.125	19.88	± 75
Middle	180.725	20.83	± 75
High	185.125	20.37	± 75

Table 10: Test results of Operating Bandwidth

Channel	Frequency (MHz)	Result (kHz)	Limit (kHz)
Low	175.125	92.3181	200
Middle	180.725	92.6984	200
High	185.125	94.7022	200

Table 11: Test results of Emission Mask

Channel	Frequency (MHz)	Result	Remark
Low	175.125	PASS	Refer to following test graphs for details
Middle	180.725	PASS	Refer to following test graphs for details
High	185.125	PASS	Refer to following test graphs for details

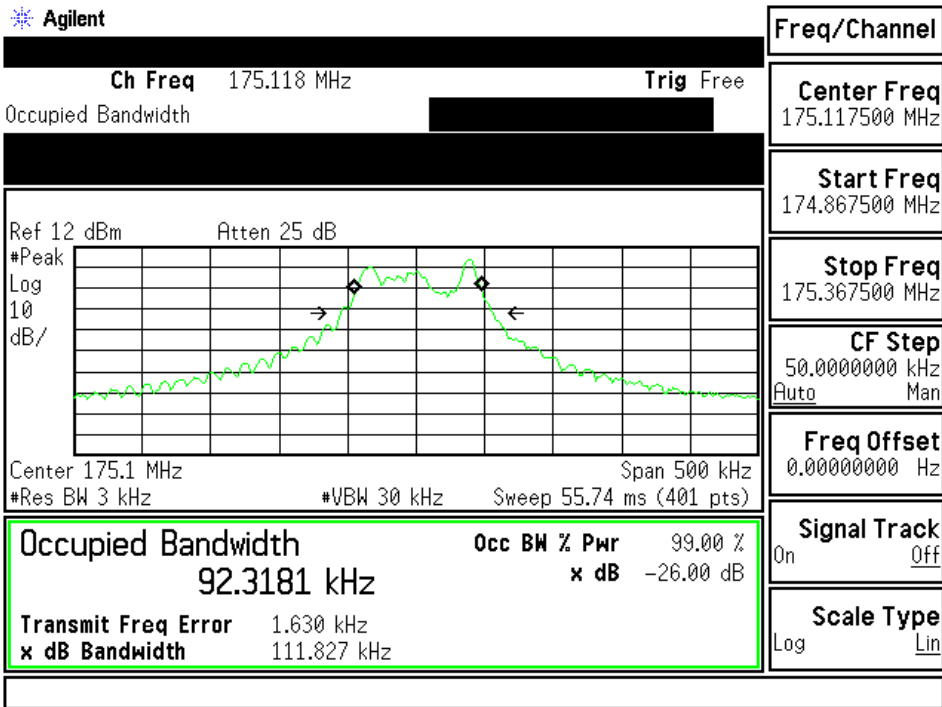
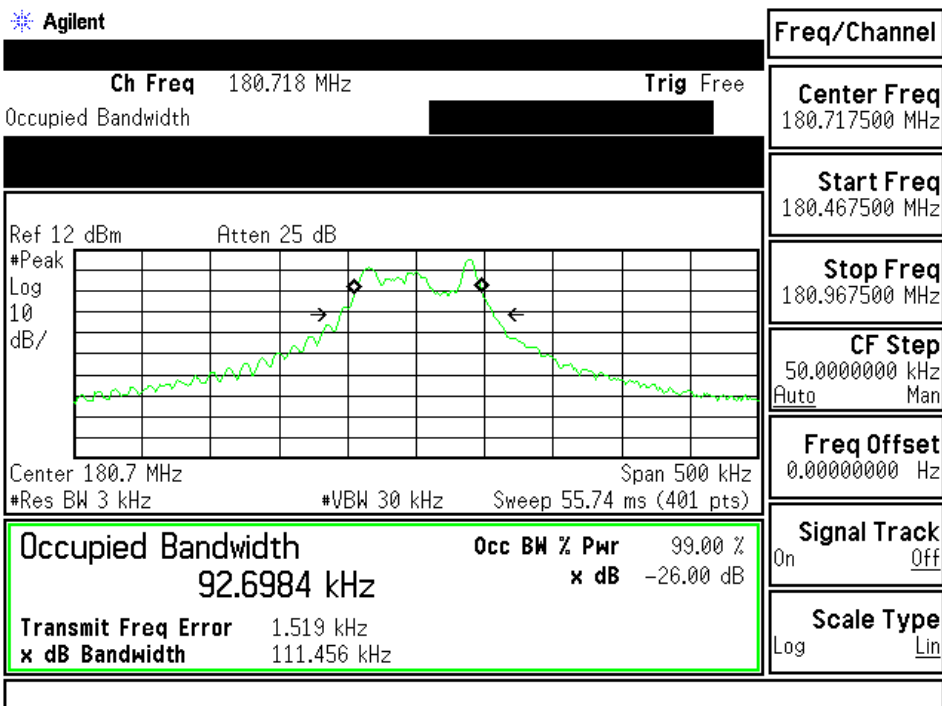
Test Graph of Operating bandwidth
Low Channel

Middle Channel

High Channel

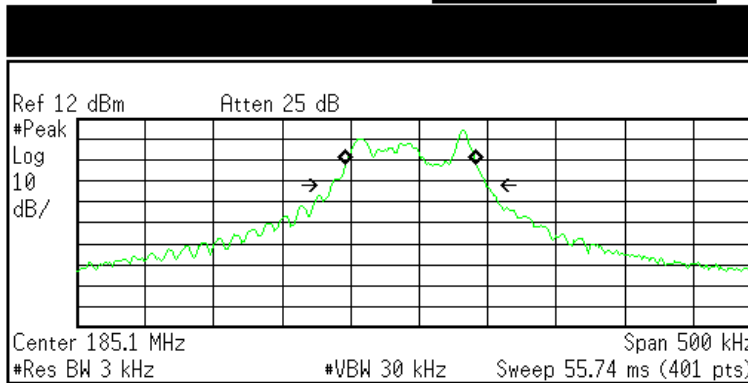

Ch Freq 185.125 MHz **Trig** Free
 Occupied Bandwidth



Occupied Bandwidth	Occ BW % Pwr	99.00 %
94.7022 kHz	x dB	-26.00 dB
Transmit Freq Error		-6.121 kHz
x dB Bandwidth		112.751 kHz

Meas Setup	
Avg Number	10
On	Off
Avg Mode	Repeat
Exp	
Max Hold	Off
On	
Occ BW % Pwr	99.00 %
OBW Span	500.000000 kHz
x dB	-26.00 dB
Optimize	Ref Level

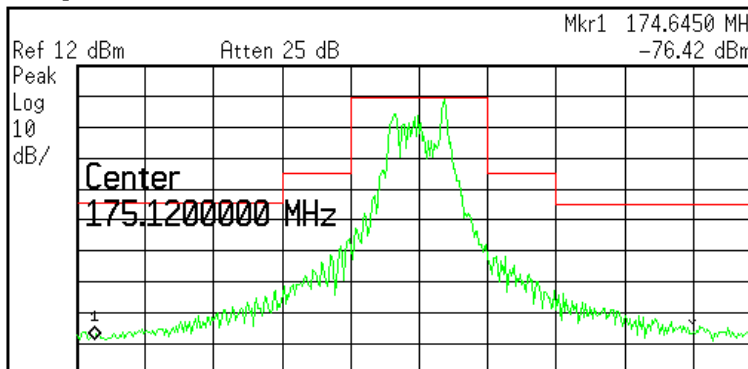
Test Graph of Emissions mask
Low Channel



Center	175.120000 MHz
Center	175.1 MHz
Span	1 MHz
#Res BW	1 kHz
#VBW	1 kHz
Sweep	1.288 s (401 pts)

Marker	Trace	Type	X Axis	Amplitude
1	(1)	Freq	174.6450 MHz	-76.42 dBm

Trace/View	
Trace	1 2 3
Clear Write	
Max Hold	
Min Hold	
View	
Blank	
More	1 of 2

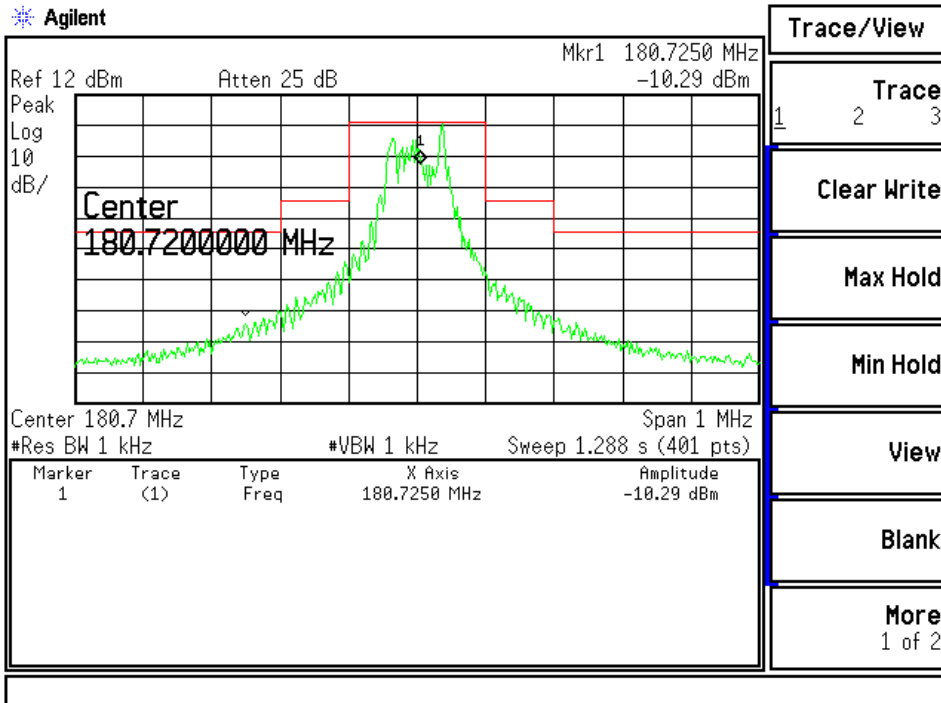
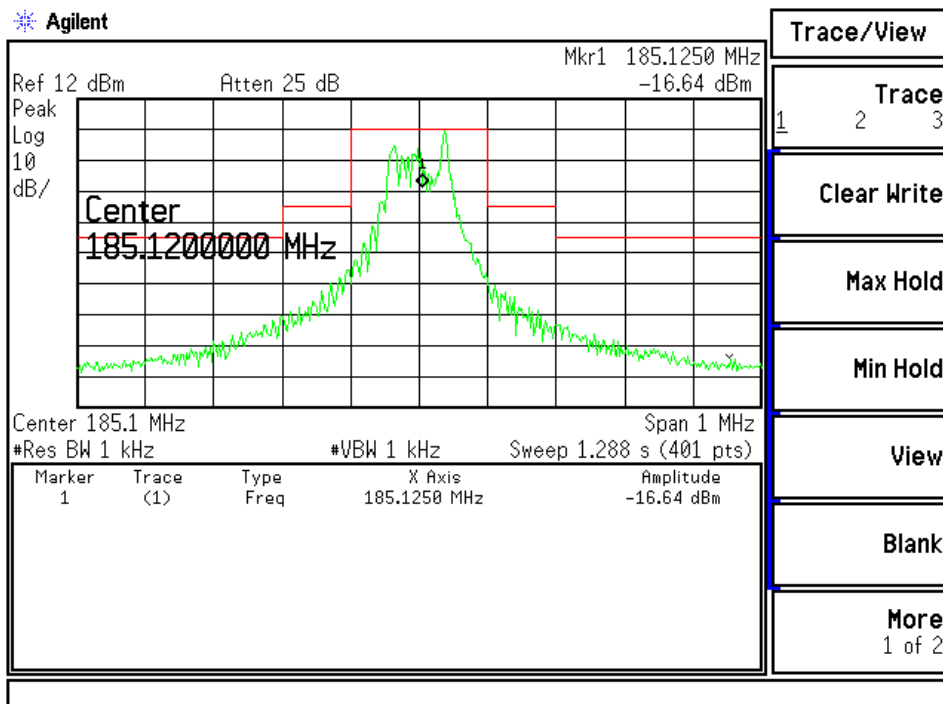
Middle Channel

High Channel

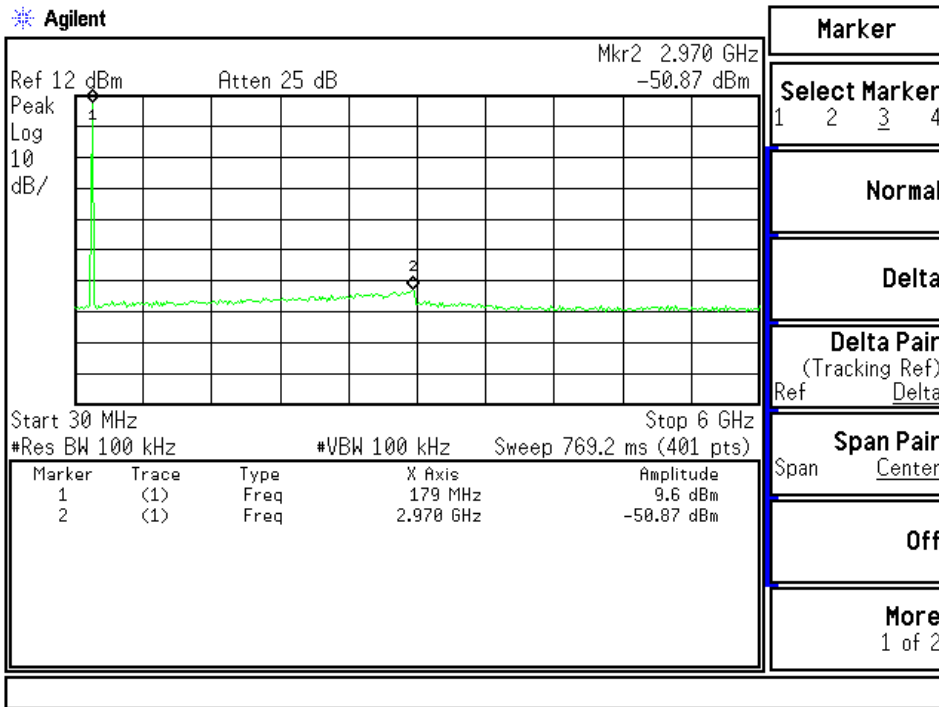
Test Graph of Conducted spurious emissions Low Channel

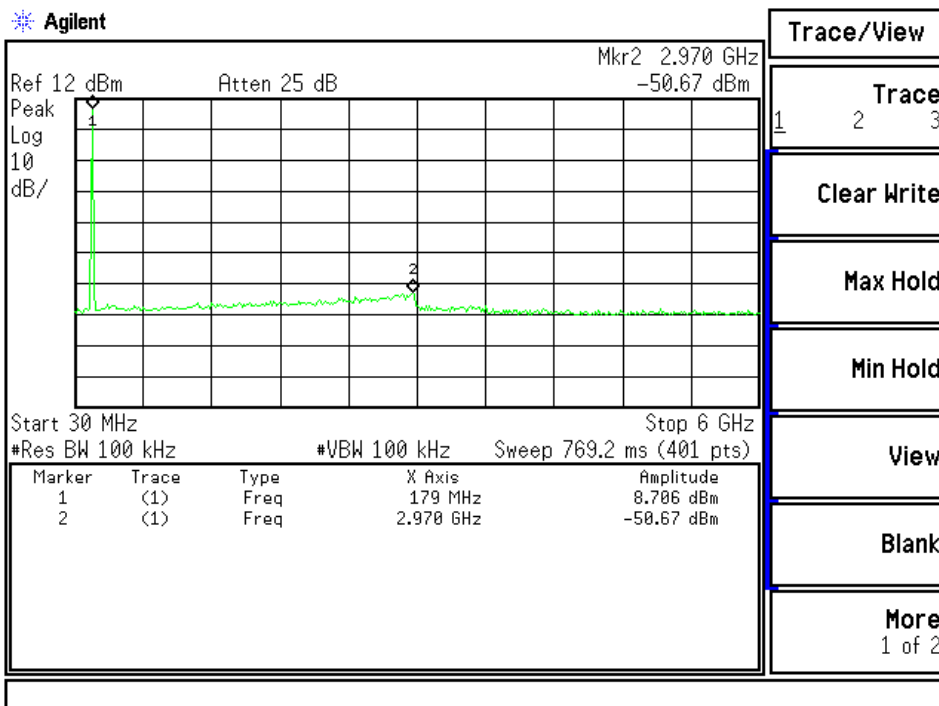

Middle Channel



High Channel

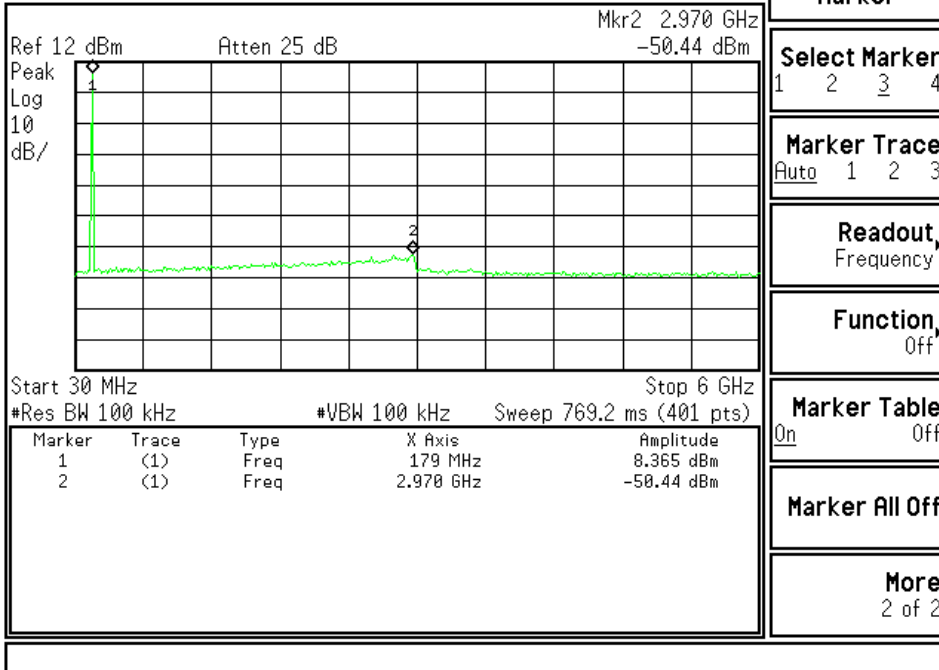

Marker
Select Marker 1 2 <u>3</u> 4
Marker Trace Auto 1 2 3
Readout Frequency
Function Off
Marker Table On Off
Marker All Off
More 2 of 2

5.1.4 Frequency Tolerance

RESULT:
Passed

Date of testing : 2012-03-16 to 2012-05-20
 Test standard : FCC Part 74.861(e)(4)
 Limits : 0.005 percent
 Kind of test site : Shield room

Test setup

Test Channel : Low/ Middle/ High
 Operation mode : A
 Ambient temperature : 24°C
 Relative humidity : 52%
 Atmospheric pressure : 101.0 kPa

Table 12: Test results of Frequency Tolerance

Test Condition	Power Supply (V)	Low Frequency (MHz) (175.125MHz)	Middle Frequency (MHz) (180.725MHz)	High Frequency (MHz) (185.125MHz)
-30°C	DC 3.0	175.126000	180.726000	185.126000
-20°C	DC 3.0	175.125750	180.725750	185.126250
-10°C	DC 3.0	175.125500	180.725750	185.126000
0°C	DC 3.0	175.125750	180.725750	185.125750
10°C	DC 3.0	175.125750	180.725750	185.125500
20°C	DC 3.0	175.124250	180.724500	185.125250
30°C	DC 3.0	175.124500	180.724500	185.124750
40°C	DC 3.0	175.124250	180.724250	185.124250
50°C	DC 3.0	175.123750	180.724000	185.124000
20°C	DC 3.3	175.124250	180.724500	185.125250
20°C	DC 3.0	175.124250	180.724500	185.125250
20°C	DC 2.7	175.124250	180.724500	185.125250
Maximum Frequency error (MHz)		-0.00125	0.001	0.00125
Frequency tolerance		0.00071%	0.00055%	0.00068%
Limit		0.005%		

5.1.5 Modulation Characteristics

RESULT:
Passed

Date of testing : 2012-03-16 to 2012-05-20
 Test standard : FCC Part 2.1047(a) & (b)
 Test method : According to clause 2.2.6.2.2 of TIA 603-C for
 Audio Frequency response testing
 According to clause 2.2.3.2 of TIA 603-C for
 Modulation Limiting testing
 Limit : FCC Part 2.1047(a) & (b)
 Kind of test site : Shield room

Test setup

Test Channel : Low/ Middle/ High
 Operation Mode : A
 Ambient temperature : 24°C
 Relative humidity : 52%
 Atmospheric pressure : 101.0 kPa

Table 13: Test results of Modulation Characteristics

Audio Frequency Response, Low channel		
Audio Frequency (Hz)	Input Level (mV)	Audio Frequency Response (dB)
100	0.41	-0.55
300	0.41	-0.45
500	0.41	-0.39
700	0.41	-0.15
1000	0.41	0.00
1500	0.41	0.28
2000	0.41	0.33
3500	0.41	1.21
4000	0.41	1.78
4500	0.41	2.13
5000	0.41	2.35
Audio Frequency Response, Middle channel		
Audio Frequency (Hz)	Input Level (mV)	Audio Frequency Response (dB)
100	0.46	-0.60
300	0.46	-0.34
500	0.46	-0.15
700	0.46	0.00
1000	0.46	0.00
1500	0.46	0.38
2000	0.46	0.61

3500	0.46	1.54
4000	0.46	2.13
4500	0.46	2.50
5000	0.46	2.78

Audio Frequency Response, High channel

Audio Frequency (Hz)	Input Level (mV)	Audio Frequency Response (dB)
100	0.41	-0.86
300	0.41	-0.60
500	0.41	-0.29
700	0.41	-0.20
1000	0.41	0.00
1500	0.41	0.78
2000	0.41	0.96
3500	0.41	1.54
4000	0.41	2.61
4500	0.41	2.68
5000	0.41	2.75

Modulation Limiting, Low channel

Modulation Level (dB)	Peak Frequency Deviation (kHz)			
	300Hz	1000Hz	2000Hz	3000Hz
-20	1.59	1.95	2.06	2.25
-15	1.91	2.5	2.68	2.89
-10	2.37	3.15	3.44	3.74
-5	3	4.07	4.47	4.84
0	4	5.38	6.24	6.98
+5	5.28	7.17	8.71	9.83
+10	6.99	9.67	12	13.13
+15	9.8	10.67	13.9	14.76
+20	15	15.6	16.7	15.64

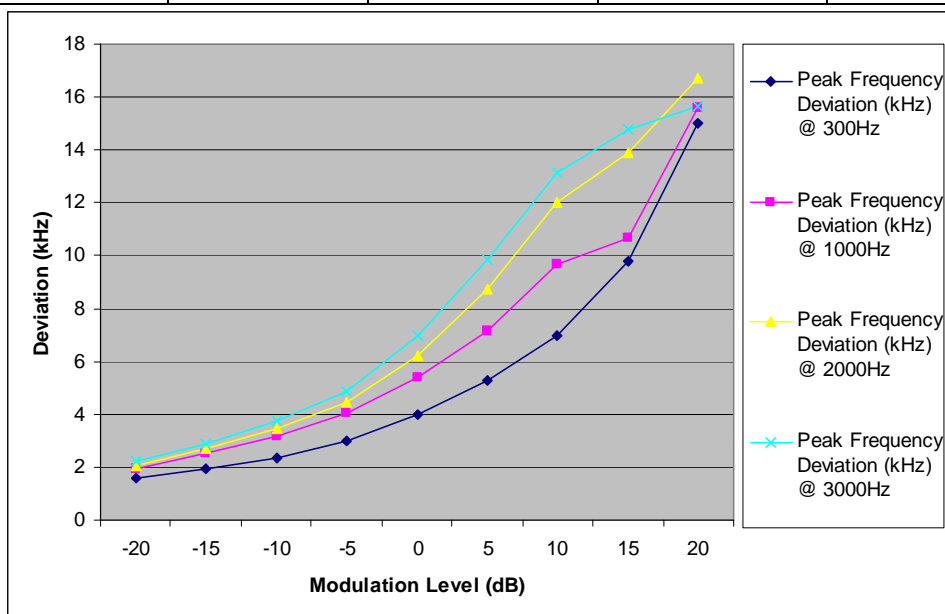

Modulation Limiting, Middle channel

Modulation Level (dB)	Peak Frequency Deviation (kHz)			
	300Hz	1000Hz	2000Hz	3000Hz
-20	1.65	2.02	2.2	2.38
-15	2.01	2.61	2.74	3.05
-10	2.51	3.16	3.54	3.8
-5	3.14	4.12	4.49	4.79
0	4.07	5.38	6.17	6.81
+5	5.46	6.95	8.45	9.54
+10	7.2	9.44	11.76	12.89
+15	9.4	9.64	13.02	13.49
+20	16.69	17.23	16.97	14.94

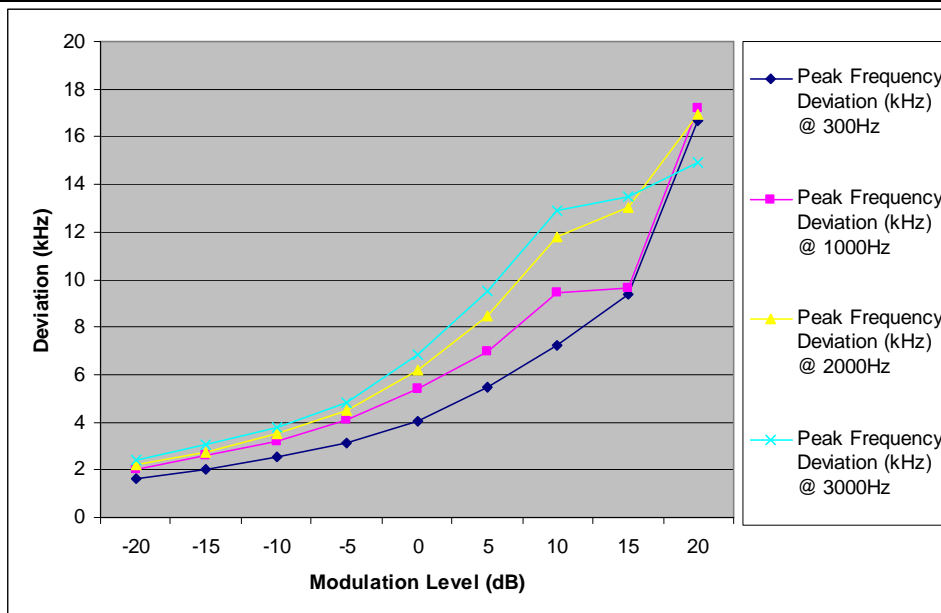

Modulation Limiting, High channel

Modulation Level (dB)	Peak Frequency Deviation (kHz)			
	300Hz	1000Hz	2000Hz	3000Hz
-20	1.68	2	2.03	2.2
-15	1.98	2.5	2.63	2.87
-10	2.55	3.18	3.45	3.7
-5	3.21	4.1	4.53	4.88
0	4.11	5.38	6.25	6.94
+5	5.35	7.29	8.86	10
+10	7.25	9.87	12.16	13.28
+15	9.85	14.06	14.5	13.38
+20	16.68	16.75	16.24	15.3

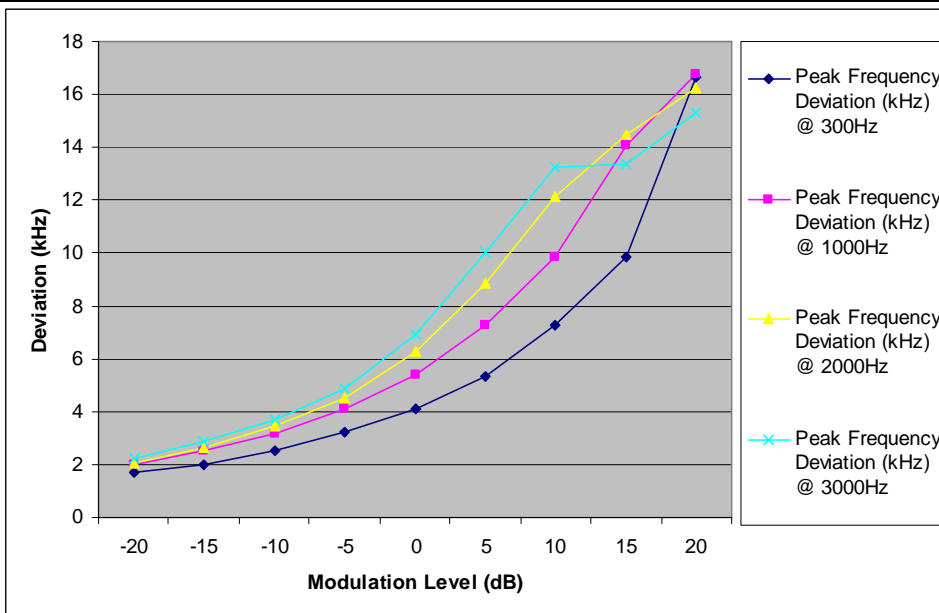

6. Safety Human exposure

6.1 Radio Frequency Exposure Compliance

6.1.1 Electromagnetic Fields

RESULT:**Passed**

Test standard : FCC KDB Publication 447498

The maximum peak output power of the transmitter is 9.11mW (9.594dBm) only. Since maximum peak output power of the transmitter is $<60/f(\text{GHz})$ mW, i.e. $9.11\text{mW} < 343 (=60/0.175)$ mW, hence the EUT is excluded from SAR evaluation according to FCC KDB publication 447498 D01: Mobile Portable RF Exposure.

7. Photographs of the Test Set-Up

Photograph 1: Set-up for Spurious Emissions (30MHz-1GHz)



Photograph 2: Set-up for Spurious Emissions (1GHz-5GHz)



8. List of Tables

Table 1: List of Test and Measurement Equipment	5
Table 2: Rating of EUT	7
Table 3: Technical Specification of EUT	7
Table 4: List of Operating Channel.....	8
Table 5: List of Test Channel	9
Table 6: Test results of Transmitter Output Power	12
Table 7: Limit Calculation	15
Table 8: Test results of Spurious Radiation Emissions.....	15
Table 9: Test results of Maximum Deviation	18
Table 10: Test results of Operating Bandwidth	18
Table 11: Test results of Emission Mask.....	18
Table 12: Test results of Frequency Tolerance.....	24
Table 13: Test results of Modulation Characteristics	25

9. List of Photographs

Photograph 1: Set-up for Spurious Emissions (30MHz-1GHz)	30
Photograph 2: Set-up for Spurious Emissions (1GHz-5GHz)	30