

Chapter 5 Occupied Bandwidth Measurement

1. Rules and Specification Limits

2.1049(c)(1): ANSI/ TIA / EIA-603-1992, Paragraph 2.2.11.

74.861(e)(3): Any form of modulation may be used. A maximum deviation of $\pm 75\text{kHz}$ is permitted when frequency modulation is employed.

74.861(e)(5): The operation bandwidth shall not exceed 200kHz.

2. Test Configuration & List of Test Instruments

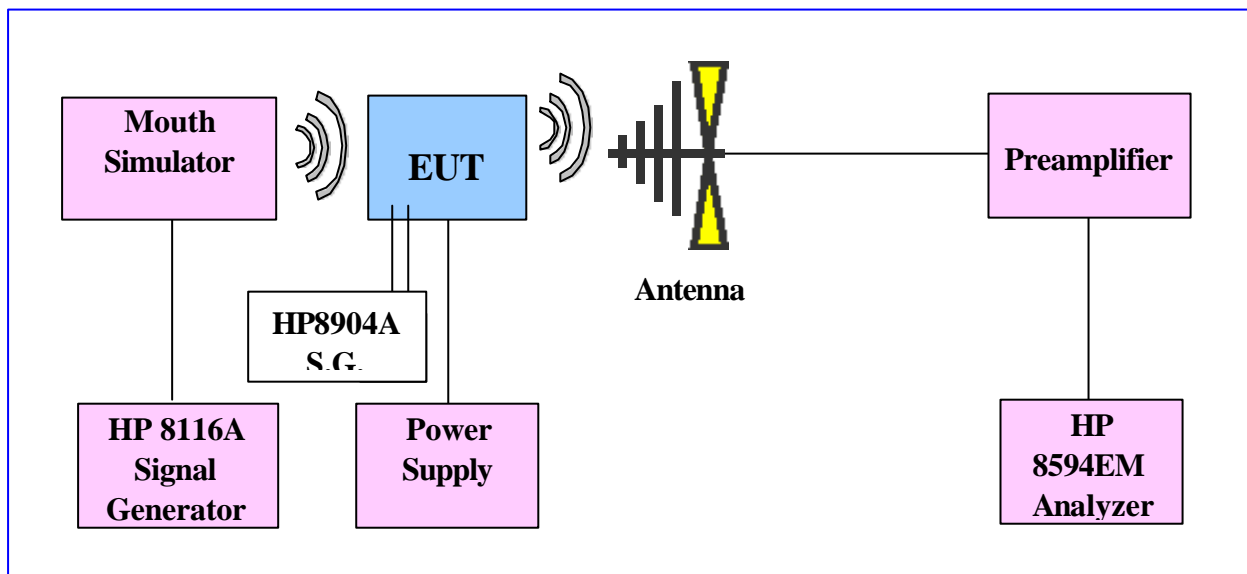

3. List of test Instrument

Instrument Name	Model No.	Brand	Input Impedance
Spectrum analyzer (9K~1.8GHz)	8594EM	HP	50
Preamplifier (30MHz~1GHz)	TRC001	TRC	50
Signal Generator 50 MHz	HP8116A	HP	50
Signal Generator	HP8904A	HP	50
Bi-log Antenna	CBL6141A	SCHAFFNER	50

4. Measurement Procedure

1. Connect the EUT as Section 4.2 .
2. Plot the unmodulated chart shows on spectrum.
3. Set the output of the signal generator to 1kHz, 2.5kHz, 9.448kHz and 15kHz. Increase the amplitude of the signal, while monitoring the modulation meter. Until modulation is max. Measure the bandwidth under 26 dB compared to the unmodulated fundamental carrier peak level of the modulated signal displayed on the spectrum analyzer.
4. The occupied Bandwidth was measured as follow pages.

Unmodulation

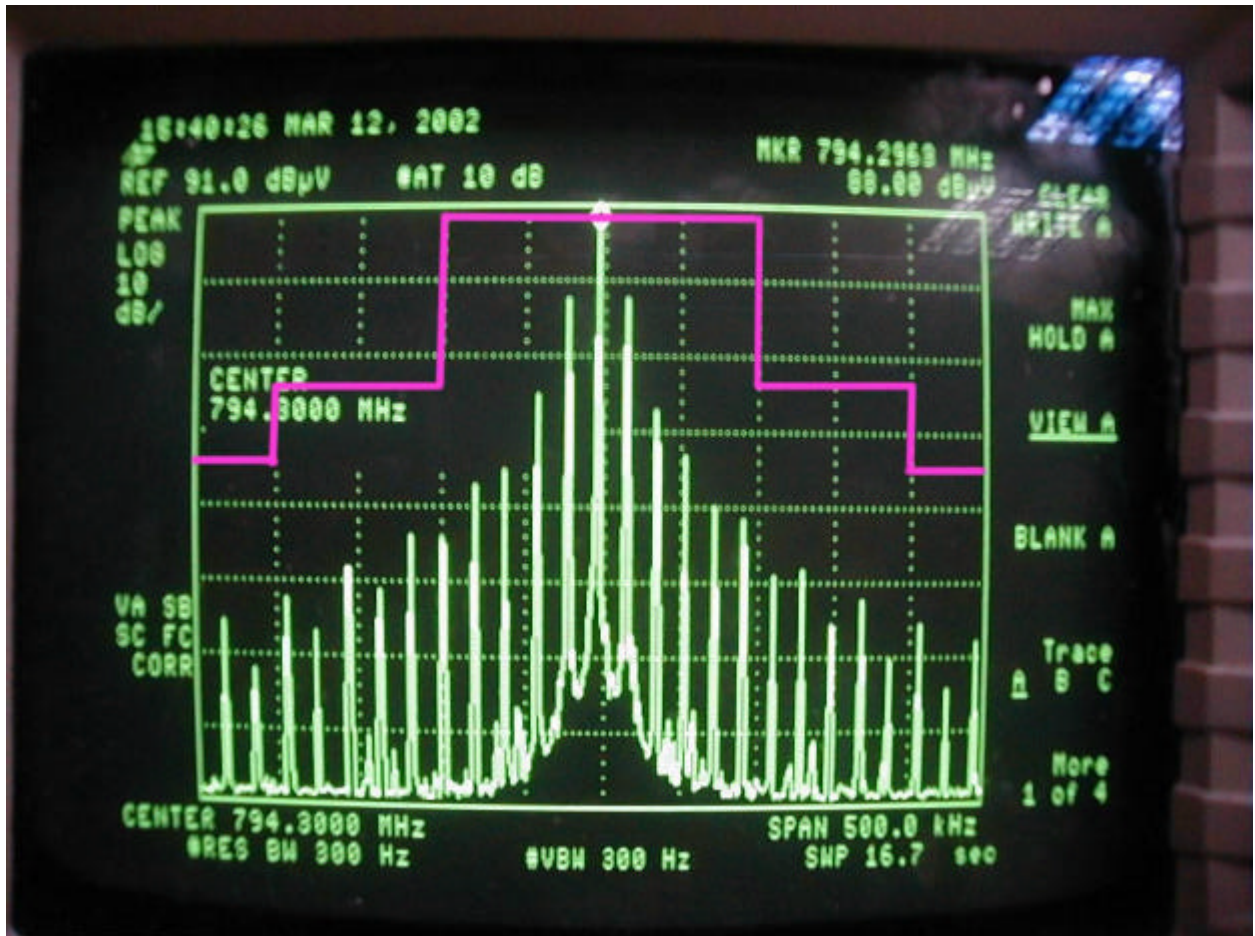

L+R1

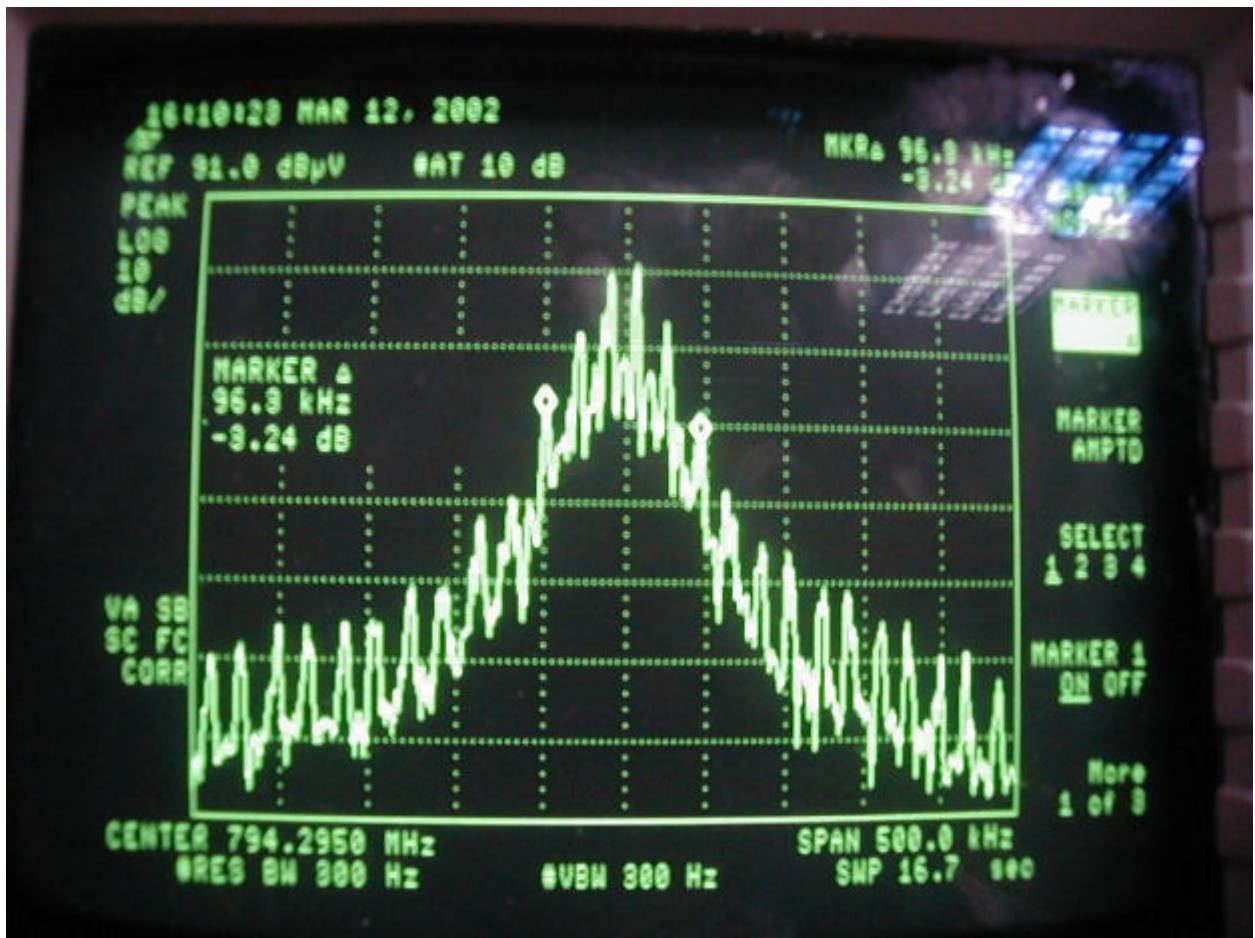

L+RIK

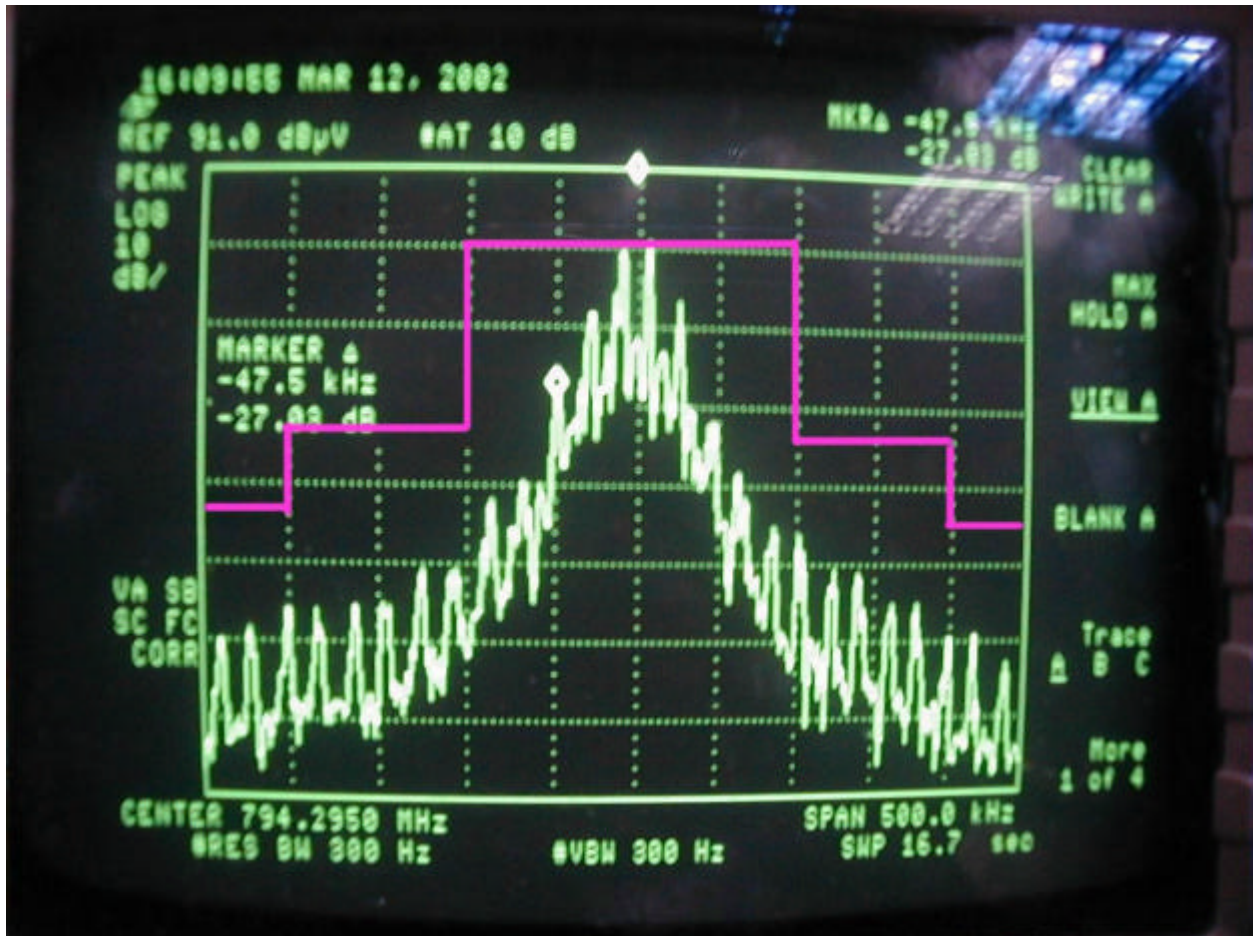

L+R2.5

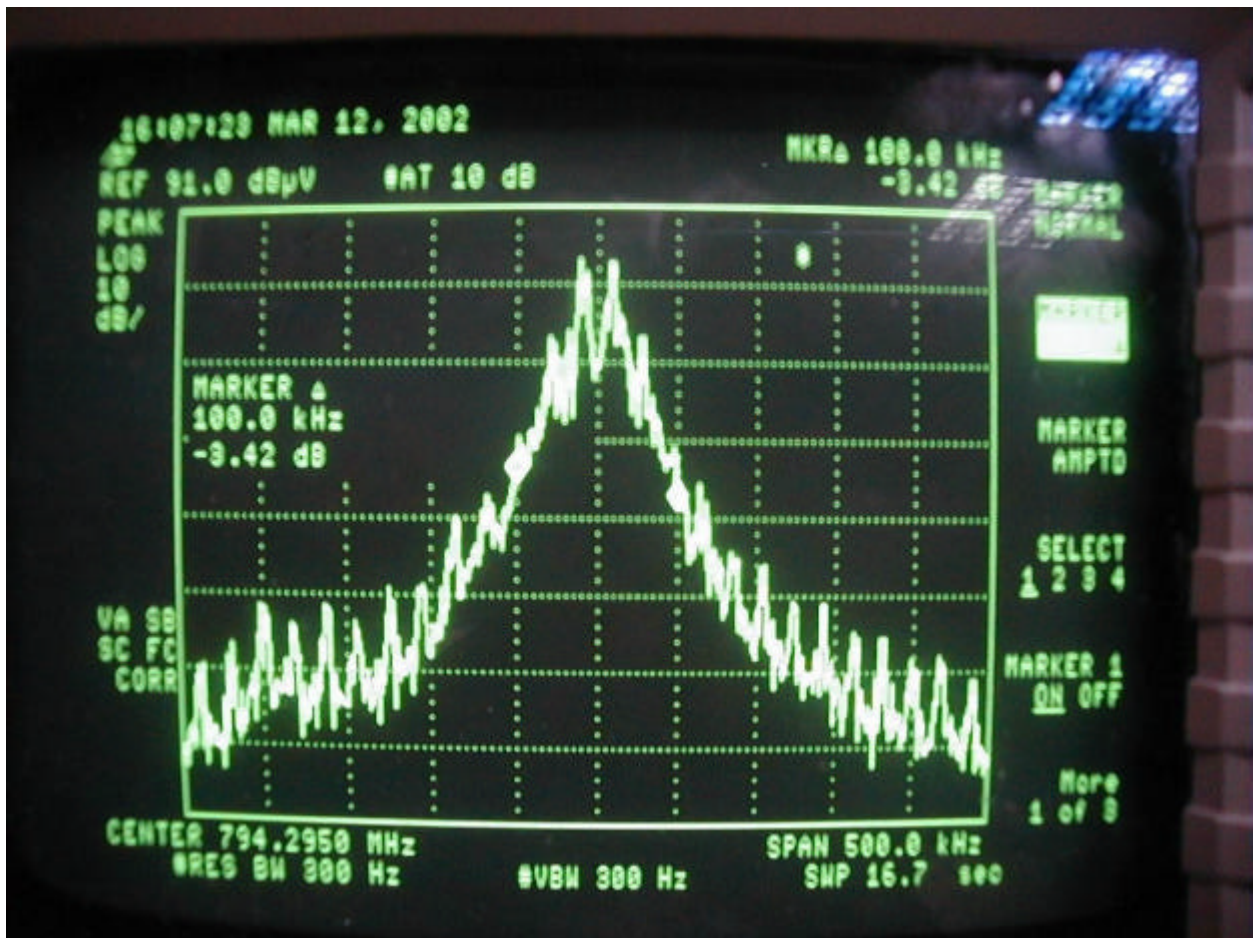

L+R2.5K

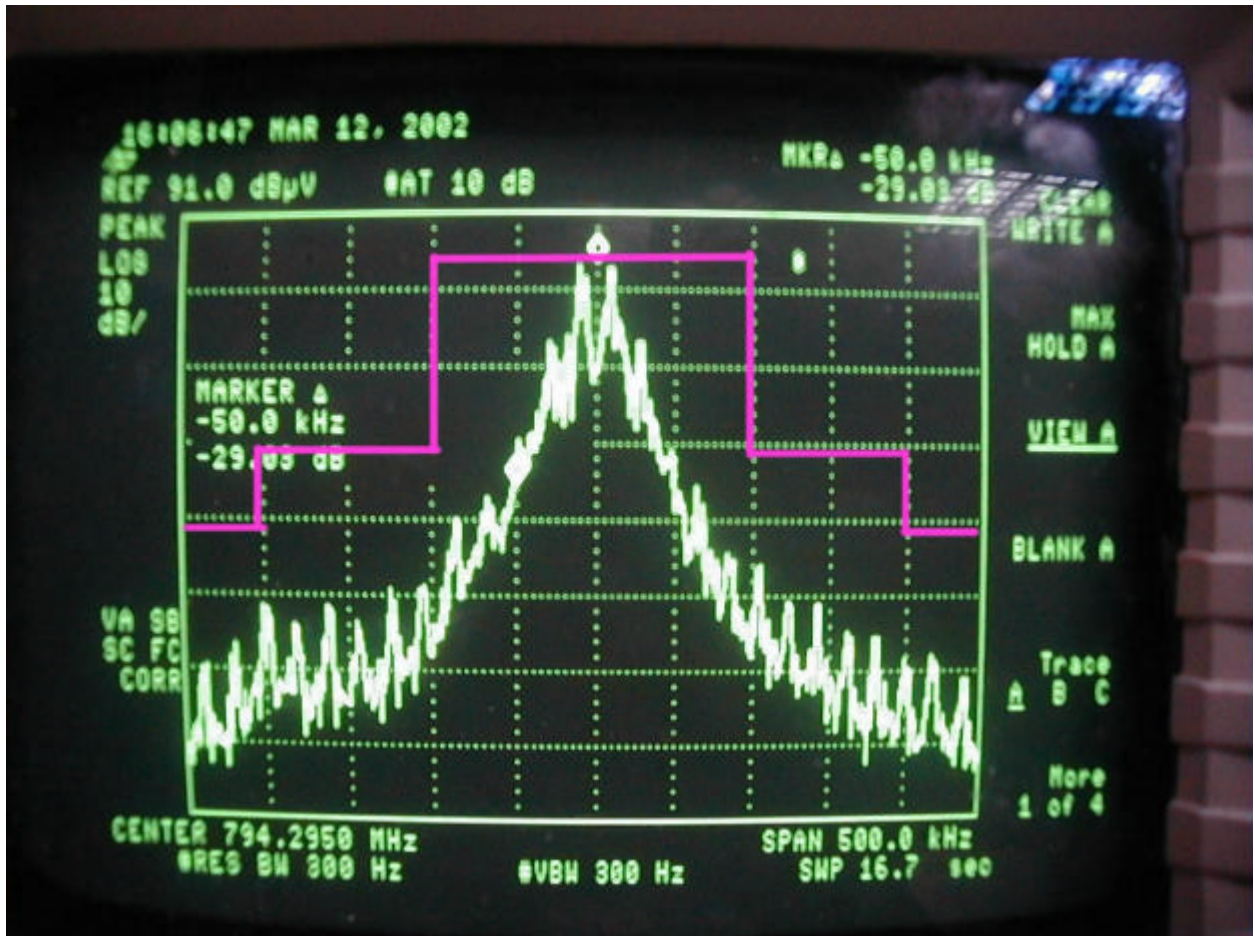

L+R9.448

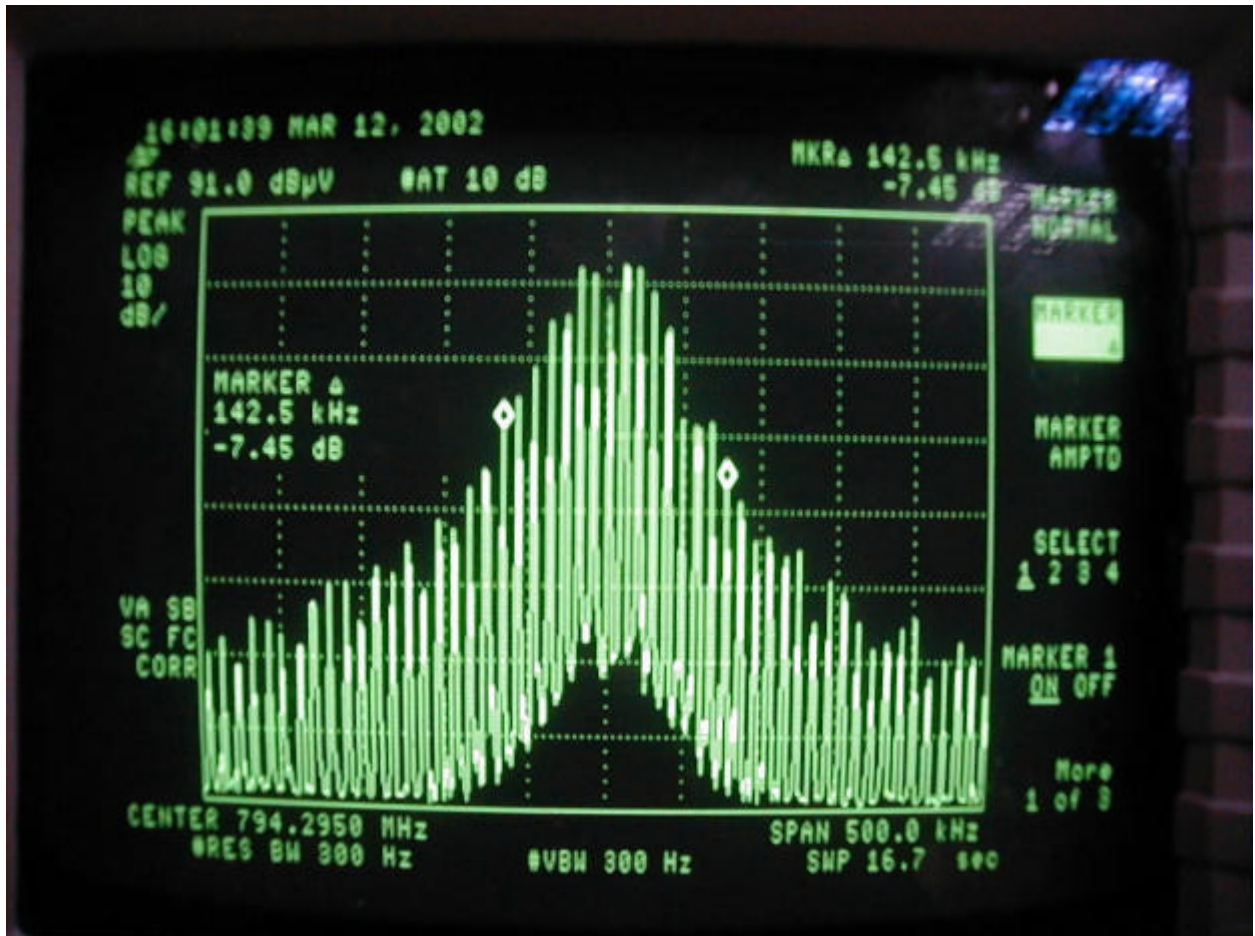

L+R9.448K

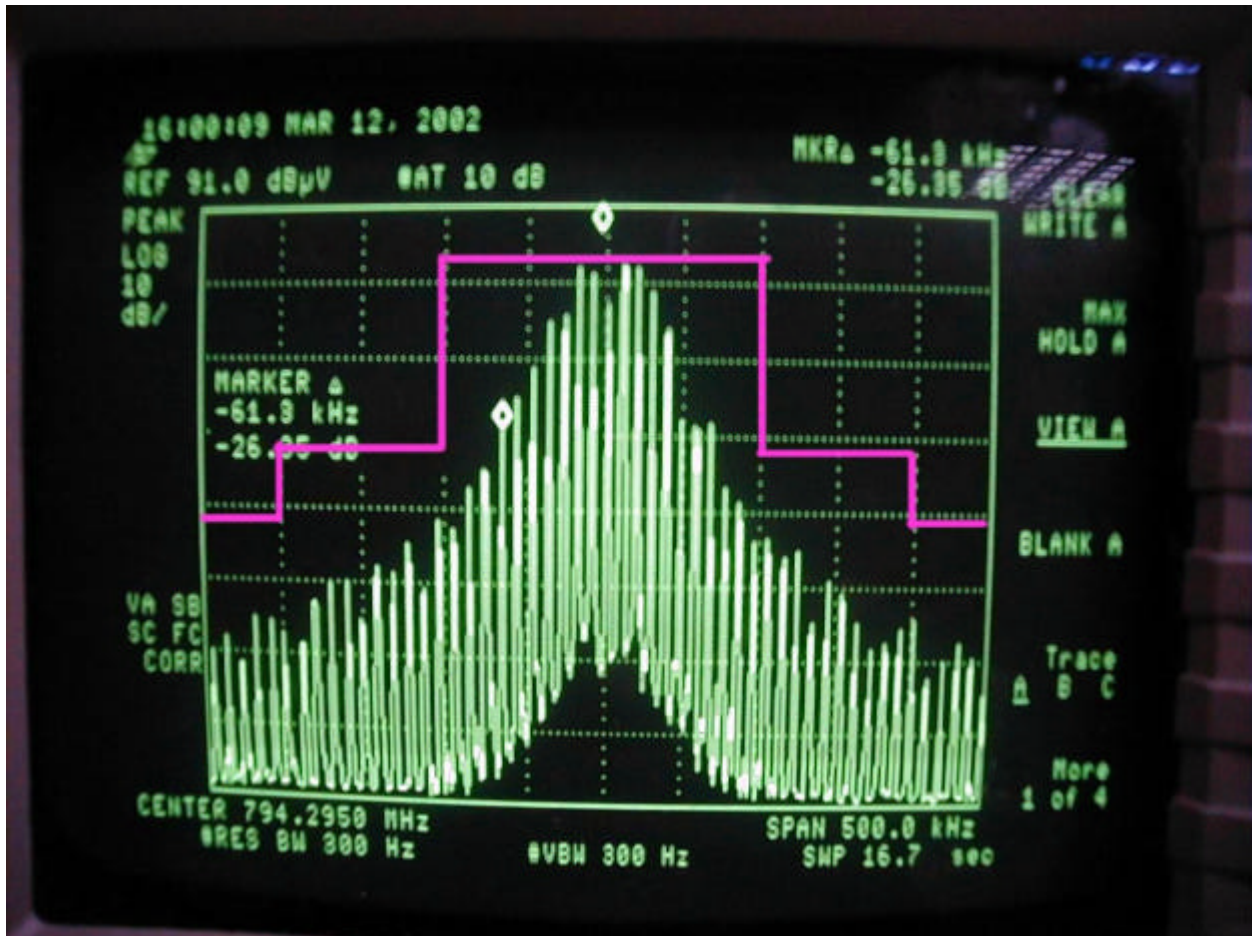

L+R15

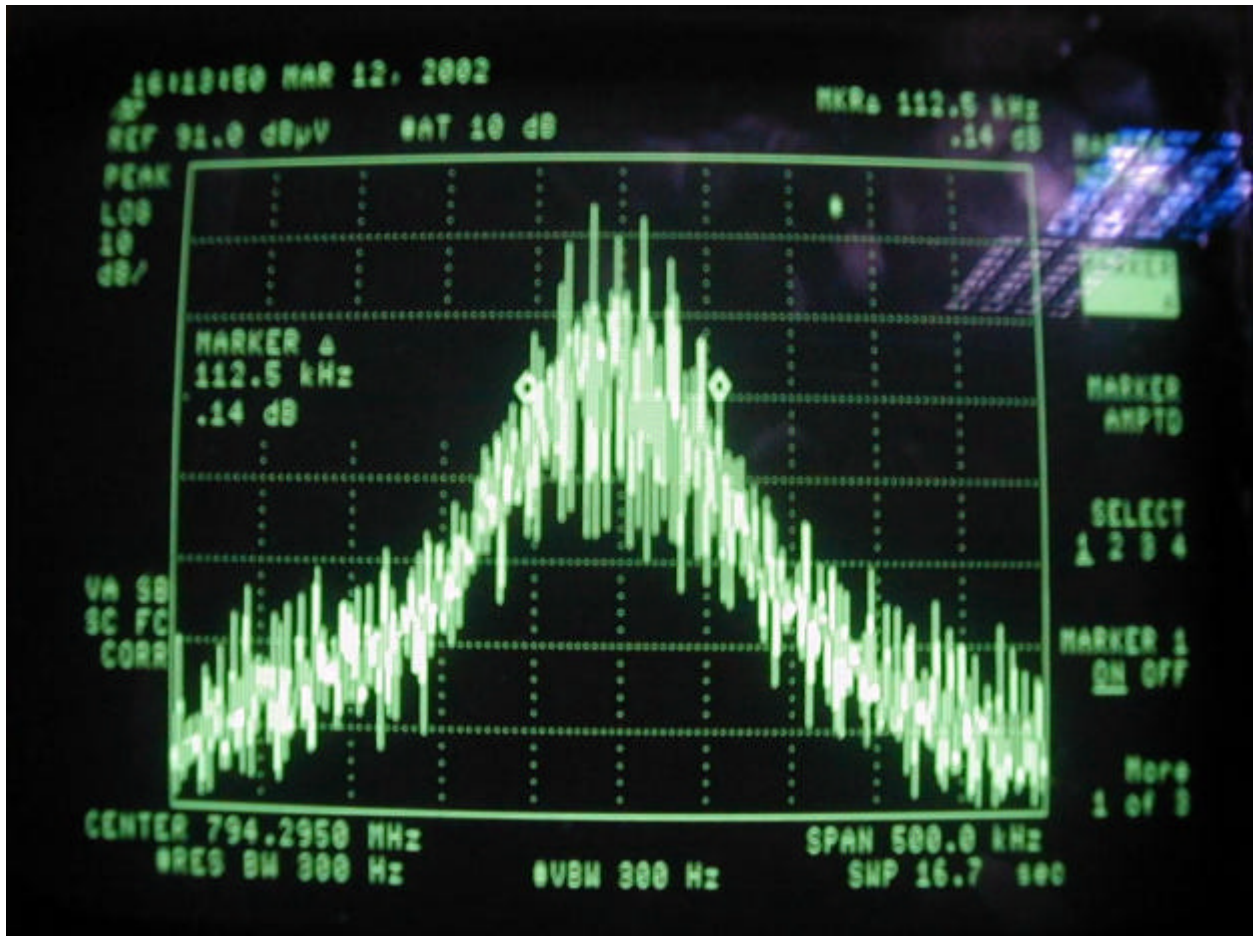

Report No.: S0774551

Training Research Co., Ltd., TEL: 886-2-26935155, Fax: 886-2-26934440

L+R15K

