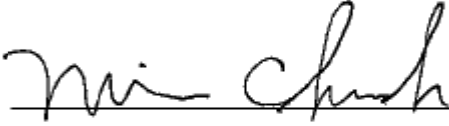
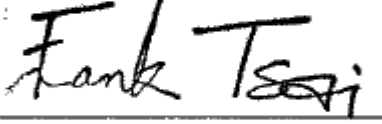

Report No.	S0774726
Specifications Test Method	FCC Part 74 – Certification ANSI C63.4 1992
Applicant address	23, Lane 2, Jing Wu Road, Taichung, Taiwan, R.O.C.
Applicant	Sekaku Electron Industry Co., Ltd.
Items tested Model No.	Wireless Microphone UB-10 (Sample # S07726)
Results Date	Compliance (As detailed within this report) 02/12/2001 (month / day / year) (Sample received) 03/23/2001 (month / day / year) (Test)
Prepared by	 Project Engineer
Authorized by	 General Manager (Frank Tsai)
Issue date	April 25, 2001 (month / day / year)
Modifications	None
Tested by	Training Research Co., Ltd.
Office at	2, Lane 194, Huan-Ho Street, Hsichih, Taipei Hsien 221, Taiwan
Anechoic Chamber at	2, Lane 194, Huan-Ho Street, Hsichih, Taipei Hsien 221, Taiwan

Conditions of issue:

- (1) This test report shall not be reproduced except in full, without written approval of TRC. And the test result contained within this report only relate to the sample submitted for testing.**
- (2) This report must not be used by the client to claim product endorsement by NVLAP or nay agency of U.S. Government.**

★ FCC ID : H38U1000

Contents

Chapter 0	Application for Certification	4
Chapter 1	General	
1.1	Introduction.....	5
1.2	Description of Support Equipment	5
1.3	Configuration of System Under Test.....	6
1.4	Location of the Measurement Site.....	6
1.5	General Test Condition.....	6
Chapter 2	Power Output Measurement	
2.1	Rules and Specification Limits.....	7
2.2	Measurement Condition and Setup	7
2.3	List of Measurement Instrument	8
2.4	Measurement Configuration.....	9
2.5	Measurement Result	10
Chapter 3	Modulation Characteristics Measurement	
3.1	Rules and Specification Limits.....	13
3.2	Test Configuration & List of Test Instruments.....	13
3.3	Frequency Response of Audio Low Pass Filter Measurement Condition & Setup	14
3.4	Modulation Limiting Measurement Condition & Setup	16
Chapter 4	Occupied Bandwidth Measurement & Calculation	
4.1	Rules and Specification Limits.....	19
4.2	Test Condition & Test Instruments.....	19
4.3	Measurement Procedure.....	20
4.4	Measurement Result	20

Chapter 5 Field Strength of Spurious Radiation Measurement

5.1 Rules and Specification Limits.....	25
5.2 Measurement Condition & Setup.....	25
5.3 List of Measurement Instruments.....	27
5.4 Measurement Configuration.....	28
5.5 Measurement Result	30

Chapter 6 Frequency Stability Tolerance Measurement

6.1 Rules and Specification limits	42
6.2 Measurement Condition & Setup with Temperature Variation.....	42
6.3 List of Measurement Instruments with Temperature Variation	42
6.4 Measurement Configuration with Temperature Variation.....	43
6.5 Measurement Result with Temperature Variation.....	44
6.6 Measurement Condition & Setup with Voltage Variation.....	46
6.7 List of Measurement Instruments with Voltage Variation.....	46
6.8 Measurement Configuration with Voltage Variation	46
6.9 Measurement Result with Voltage Variation	47

Chapter 0 Application for Certification

- 2.1033 (c)(1) : **Sekaku Electron Industry Co., Ltd.** – applicant and manufacturer
- 2.1033 (c)(2) : The equipment is a transmitter, wireless microphone
Model No.: UB-10
- 2.1033 (c)(3) : Quantity production is planned. See Exhibit C
- 2.1033 (c)(4) : Type of emission – F3E- FM Modulation
- 2.1033 (c)(5) : 100Hz ~ 10.724KHz
- 2.1033 (c)(6) : 1.107 mW
- 2.1033 (c)(7) : Specification of 250 mW is met by the equipment in the applicable
Part 74.861 (e)(1)
- 2.1033 (c)(8) : Final RF amplifier stage current : 9V
- 2.1033 (c)(9) : Description follows
- 2.1033 (c)(10) : Complete circuit diagrams are included. No modification was made
- 2.1033 (c)(11) : See Exhibit A. Instruction sheet to user included
- 2.1033 (c)(12) : See Exhibit F.
- 2.1033 (c)(13) : N/A
- 2.1033 (c)(14) : Description follows.
- 2.1033 (c)(15) : N/A
- 2.1033 (c)(16) : N/A
- 2.1033 (c)(17) : N/A

Chapter 1 GENERAL

1.1 Introduction :

The following measurement report is submitted on behalf of Sekaku Electron Industry Co., Ltd. in support of a wireless microphone certification in accordance with FCC Rules. 2.1031, 2.1046, 2.1047, 2.1049, 2.1053, 2.1055, 74.801 and 74.861.

Description of EUT :

EUT	:	WIRELESS MICROPHONE
Model No.	:	UB-10
Carrier Frequency Range	:	794 ~ 806 MHz
RF Power Output	:	1.107 mW
Supply Voltage	:	DC 9V
Supply Current	:	30 mA
Frequency Response	:	100Hz ~ 10.724KHz
Frequency Stability	:	0.005%
Operating Temperature	:	- 30 to + 50 degree centigrade

Wireless microphone is a transmitter which operates in the frequency range of 794 ~ 806 MHz. (794.900MHz, 800.200MHz and 804.900MHz tested) This microphone is worn by a performer and other participants in a program, filming, reporting ...etc.

1.2 Description of Support Equipment :

N/A

1.3 Configuration of Test Setup

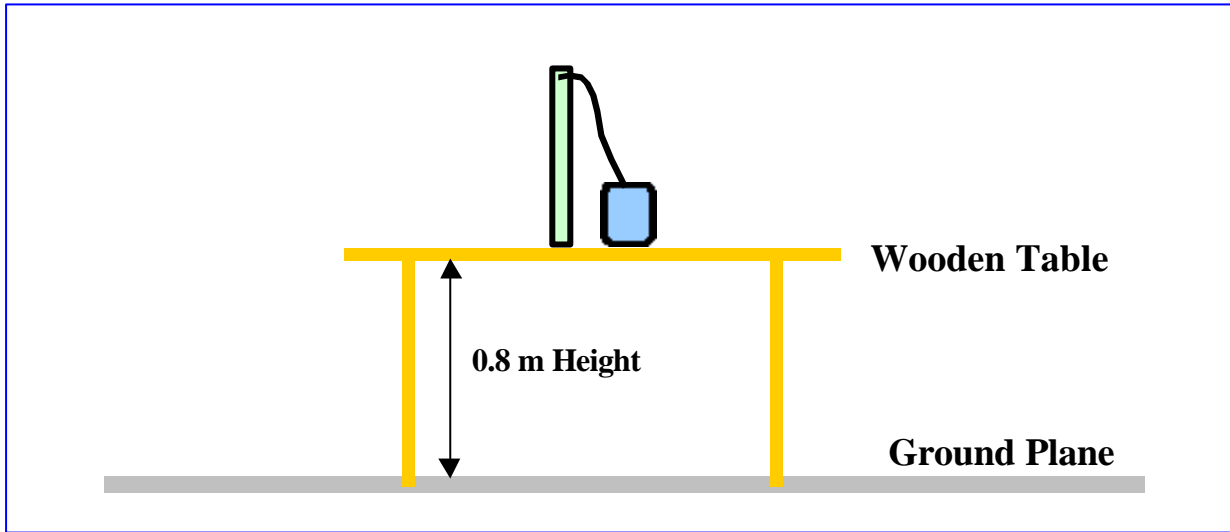

1.4 Location of the Measurement Site :

The radiated emissions measurements required by the Rules were performed on the Three-meter, anechoic chamber at test site maintained by **Training Research Co., Ltd.**, No. 2, Lane 194, Huan-Ho Street, Hsichih, Taipei Hsien 221, Taiwan. Complete description and measurement data have been placed on file with the Commission. The conducted power line Emissions tests were performed in a shielded enclosure also located at the above facility.

Training Research Co., Ltd. is listed by the FCC (Registration Number: 93906) as a facility available to do measurement work for others on a contract basis.

1.5 General Test Condition :

The conditions under which the EUT operates were varied to determine their effect on the equipment's emission characteristics. The final configuration of the test system and the mode of operation used during these tests were chosen as that which produced the highest emission levels. However, only those conditions, which the EUT was considered likely to encounter in normal use were investigated.

Chapter 2 Power Output Measurement

2.1 Rules and Specification Limits

2.1046(a), ANSI/ TIA/ EIA-603-1992, Paragraph 2.2.1.

74.861 (e)(1) : The power of the measured unmodulated carrier power at output of the transmitter power amplifier (antenna input power) may not exceed the following:

1. 54 – 72, 76 – 88 and 174 – 216 MHz band 50 mW.
2. 470 – 608 and 614 – 806 MHz band 250 mW.

2.2 Test condition and setup :

1. Measurement was made on anechoic chamber. The EUT system was placed on non-conductive turntable which is 0.8 meters height, top surface 1.0 X 1.5 meter. The EUT was placed in three direction of the space in order to obtain maximum emission.
2. A SCHAFFNER whole range antenna with horizontal and vertical polarization was raised from 1 – 4 meter as well as the turntable was rotate from 0 to 360 degree to search for the maximum Field Strength Spectrum where the spectrum analyzer was operated in the quasi-peak detection mode. Recorded all the values, which measured under horizontal and vertical position for the bi-long antenna.
3. The following procedures were used to convert the emission levels measured in decibels referenced to 1 micro volt (dBμV) into field intensity in Watt.
 - (1) The actual field intensity in decibels referenced to 1 micro volt per meter (dBμV/m) is determined by algebraically adding the measured reading in dBμV, the antenna factor (dB), and cable loss (dB) at the appropriate frequency.
 - (2) The field intensity in Volt can then be determined by the following equation:
$$FI(\text{Volt}) = 10^{FI(\text{dB}\mu\text{V}/\text{m}) / 20} \times 10^{-6}$$

$$FI_a(\text{dBmV}/\text{m}) = FI_r(\text{dBmV}) - \text{Corrected (dB)}$$

$$\text{Corrected (dB)} = AF(\text{dB}) + [CL(\text{dB}) - \text{Amplitude Gain}]$$

FI_a : Actual Field Intensity

FI_r : Reading of the Field Intensity

AF : Antenna Factor

CL : Cable Loss

The field intensity in Watt can then be determined by the following equation :

$$P \text{ (watt)} = FI^2 \text{ (Volt)} \times d^2 \text{ (meter)} / 49.2$$

P : Power in Watt

D : Measurement Distance (3 m)

2.3 List of test Instrument :

Instrument Name	Model No.	Brand	Serial No.	Calibration Date	
				Last time	Next time
EMI Receiver	8546A	H P	3520A00242	10/01/00	10/01/01
RF Filter Section	85460A	H P	3448A00217	10/01/00	10/01/01
Bi-log Antenna	CBL6141A	Schaffner	4151	06/28/00	06/28/01
Switch/Control Unit (> 30MHz)	3488A	HP	N/A	11/20/00	11/20/01
Auto Switch Box (> 30MHz)	ASB-01	TRC	9904-01	11/20/00	11/20/01
Spectrum Analyzer	8564E	HP	US36433002	08/03/00	08/03/01
Microwave Preamplifier	83051A	HP	3232A00347	08/04/00	08/04/01
Horn Antenna	3115	EMCO	9704 – 5178	08/09/00	08/09/01

The level of confidence of 95%, the uncertainty of measurement of radiated emission is ± 4.96 dB.

2.4 Measurement Configuration

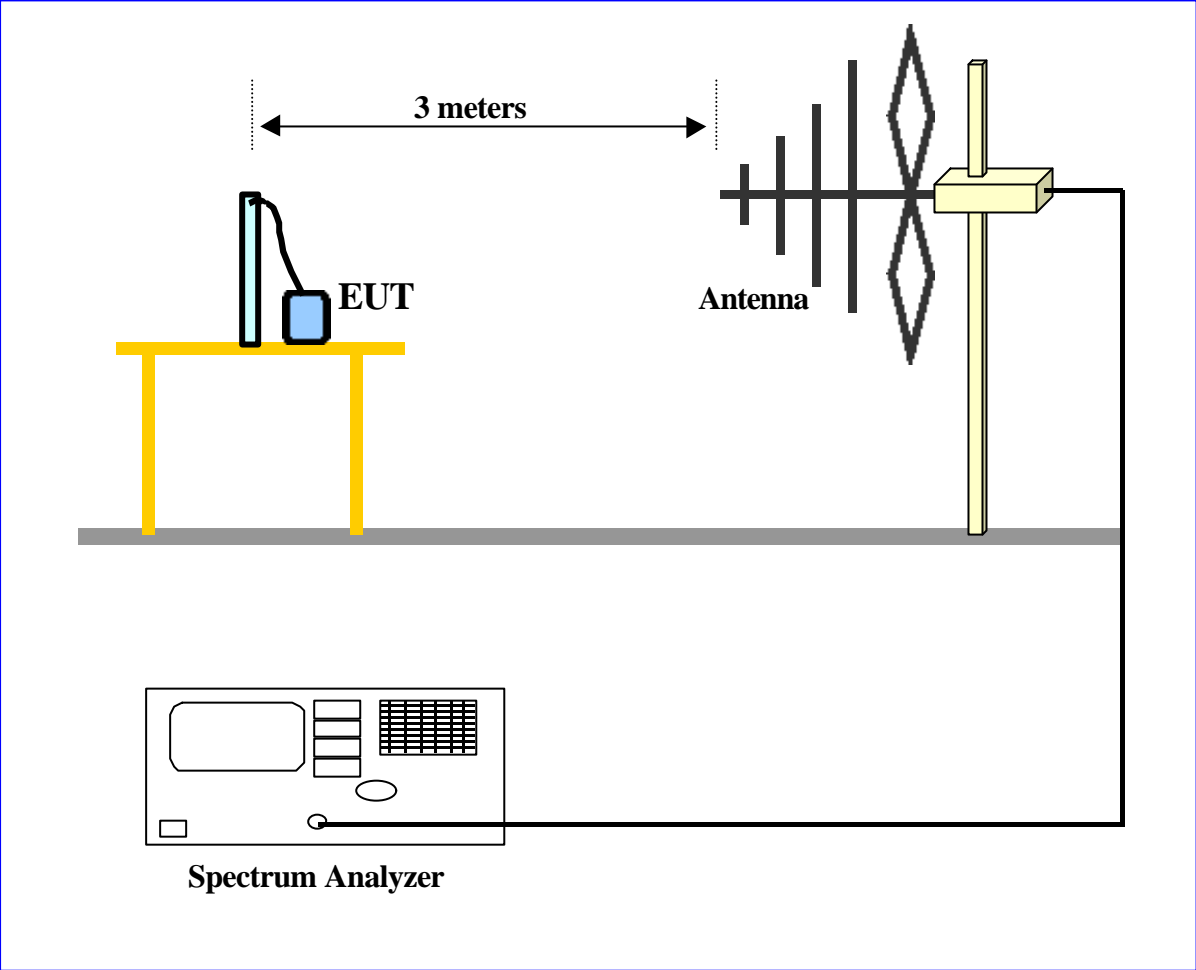

2.5 Measurement Result

(1) Frequency: 794.900 MHz

$$\begin{aligned} \text{Corrected (dB)} &= \text{AF(dB)} + [\text{CL(dB)} - \text{Amplitude Gain}] \\ &= -26.25 \text{ dB/m} \end{aligned}$$

$$\begin{aligned} \text{FI}_a \text{ (dBmV/m)} &= \text{FI}_r \text{ (dBmV)} - \text{Corrected (dB)} \\ &= 70.09 - (-26.25) \\ &= 96.34 \text{ dBmV/m} \end{aligned}$$

The maximum field measured is 96.34 dBmV/m

$$\text{FI (Volt)} = 10^{96.34/20} \times 10^{-6} = 0.06561 \text{ V}$$

$$\text{FI (mW)} = (0.06561 \times 3)^2 / 49.2 = 0.787549 \text{ mW}$$

Angle of Turn Table (°)	Spectrum Reading (dB μ V/m)	Corrected (dB)	Actually Value (dB μ V/m)	E. R. P. (mW)	8 Position of Average (mW)
0°	62.63	-26.25	88.88	0.14134	0.32868
45°	67.77	-26.25	94.02	0.46161	
90°	66.46	-26.25	92.71	0.34141	
135°	65.03	-26.25	91.28	0.24563	
180°	68.79	-26.25	95.04	0.58382	
225°	69.49	-26.25	95.74	0.68593	
270°	61.86	-26.25	88.11	0.11838	
315°	58.23	-26.25	84.48	0.05132	

(2) Frequency: 800.200 MHz

$$\begin{aligned} \text{Corrected (dB)} &= \text{AF(dB)} + [\text{CL(dB)} - \text{Amplitude Gain}] \\ &= -26.64 \text{ dB/m} \end{aligned}$$

$$\begin{aligned} \text{FI}_a \text{ (dBmV/m)} &= \text{FI}_r \text{ (dBmV)} - \text{Corrected (dB)} \\ &= 71.18 - (-26.64) \\ &= 97.82 \text{ dBmV/m} \end{aligned}$$

The maximum field measured is 97.82 dBmV/m

$$\text{FI (Volt)} = 10^{97.82/20} \times 10^{-6} = 0.07780 \text{ V}$$

$$\text{FI (mW)} = (0.07780 \times 3)^2 / 49.2 = 1.107331 \text{ mW}$$

Angle of Turn Table (°)	Spectrum Reading (dB μ V/m)	Corrected (dB)	Actually Value (dB μ V/m)	E. R. P. (mW)	8 Position of Average (mW)
0°	65.42	-26.64	92.06	0.29395	0.35644
45°	66.54	-26.64	93.18	0.38043	
90°	67.15	-26.64	93.79	0.43780	
135°	60.77	-26.64	87.41	0.10076	
180°	65.35	-26.64	91.99	0.28925	
225°	70.40	-26.64	97.04	0.92529	
270°	65.53	-26.64	92.17	0.30149	
315°	61.62	-26.64	88.26	0.12254	

(3) Frequency: 804.900 MHz

$$\begin{aligned} \text{Corrected (dB)} &= \text{AF(dB)} + [\text{CL(dB)} - \text{Amplitude Gain}] \\ &= -26.17 \text{ dB/m} \end{aligned}$$

$$\begin{aligned} \text{FI}_a \text{ (dBmV/m)} &= \text{FI}_r \text{ (dBmV)} - \text{Corrected (dB)} \\ &= 67.15 - (-26.17) \\ &= 93.32 \text{ dBmV/m} \end{aligned}$$

The maximum field measured is 93.32 dBmV/m

$$\text{FI (Volt)} = 10^{93.32/20} \times 10^{-6} = 0.04634 \text{ V}$$

$$\text{FI (mW)} = (0.04634 \times 3)^2 / 49.2 = 0.392896 \text{ mW}$$

Angle of Turn Table (°)	Spectrum Reading (dB μ V/m)	Corrected (dB)	Actually Value (dB μ V/m)	E. R. P. (mW)	8 Position of Average (mW)
0°	62.60	-26.17	88.77	0.13781	0.18519
45°	65.97	-26.17	92.14	0.29942	
90°	65.29	-26.17	91.46	0.25602	
135°	60.98	-26.17	87.15	0.09490	
180°	64.20	-26.17	90.37	0.19919	
225°	66.62	-26.17	92.79	0.34776	
270°	60.66	-26.17	86.83	0.08816	
315°	58.86	-26.17	85.03	0.05825	

Chapter 3 Modulation Characteristics Measurement

3.1 Rules and Specification Limits

2.1047 (a), ANSI/ TIA/ EIA-603-1992, Paragraph 2.2.6.

Voice modulated communication equipment

2.1047 (b), ANSI/ TIA/ EIA-603-1992, Paragraph 2.2.3.

Equipment which employs modulation limiting

3.2 Test Configuration & List of Test Instruments

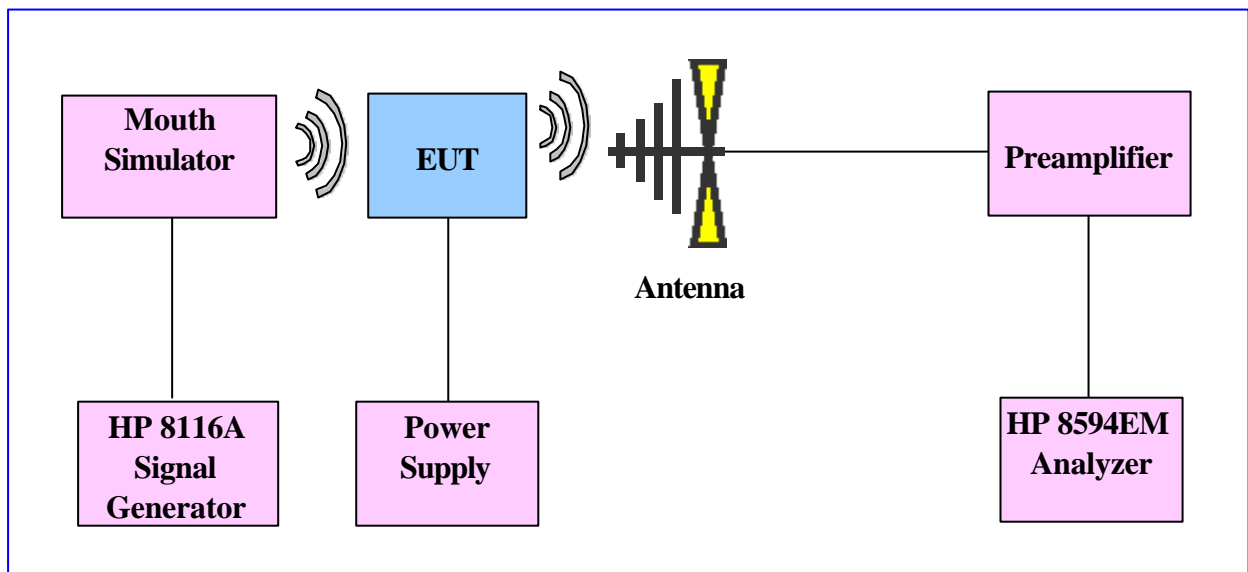

List of test instrument:

Manufacturer	Device	Model No.	Input Impedance
HP	Dynamic Signal Analyzer	HP35660A	50
HP	Signal Generator 50 MHz	HP8116A	50
SCHAFFNER	Bi-log Antenna	CBL6141A	50
Farnell	Modulation Meter	AMM2000	50
TRC	Preamplifier	TRC001	50
B&K	Mouth Simulator	4227	50

3.3 Frequency Response of Audio Modulation Circuit and Low Pass Filter Measurement Condition & Setup

2.1047 (a)

1. The EUT and test equipment were set up as shown on the Section 4.2.
2. The Plus/Function generator was connected to the microphone of EUT, via an artificial mouth simulator.
3. The audio signal input was adjusted to obtain 50% modulation at 1 kHz.
4. With input levels held constant and below limiting at all frequencies, the generator was varied from 100 Hz to 51.3 kHz.
5. The response in dBm relative to 1kHz was then measured, using the HP 35660A Dynamic Signal Analyzer as follow page.

Offset: OFF
X Ref: 51.2 kHz

Y Ref: -26.99 dBm

Meas

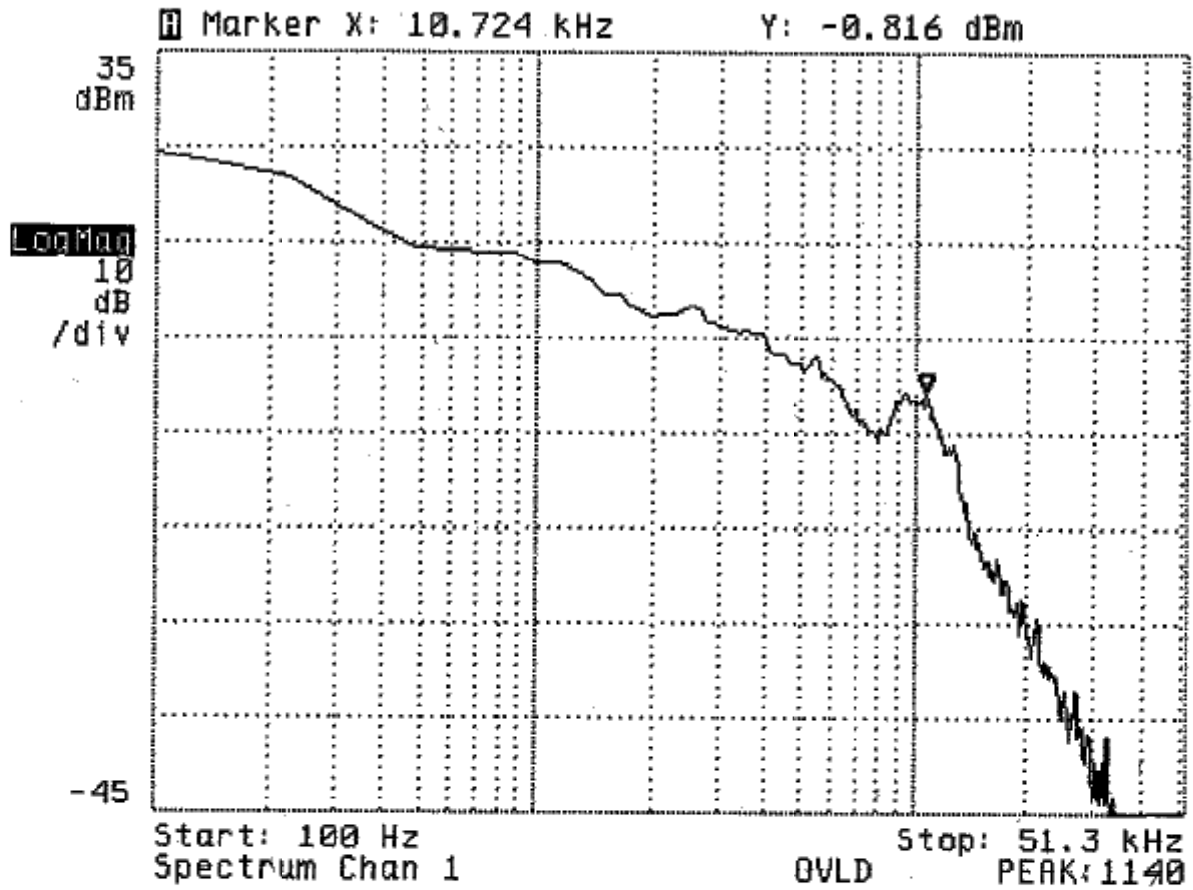

3.4 Modulation Limiting Measurement Condition & Setup

2.1047 (b)

1. The Plus/Function generator was connected to the microphone of EUT, via an artificial mouth simulator.
2. The modulation response was measured for each of four frequencies: 100Hz, 1kHz, 5.476kHz and 10.724kHz.
3. The input level was varied from 30% modulation to at least 20dB higher than the saturation point.
4. Measurements were performed for both negative and positive modulation and the respective results were recorded.
5. Measurement results as Chart 3.1 to 3.2

Chart 3.1 Modulation Limiting Measurement Negative

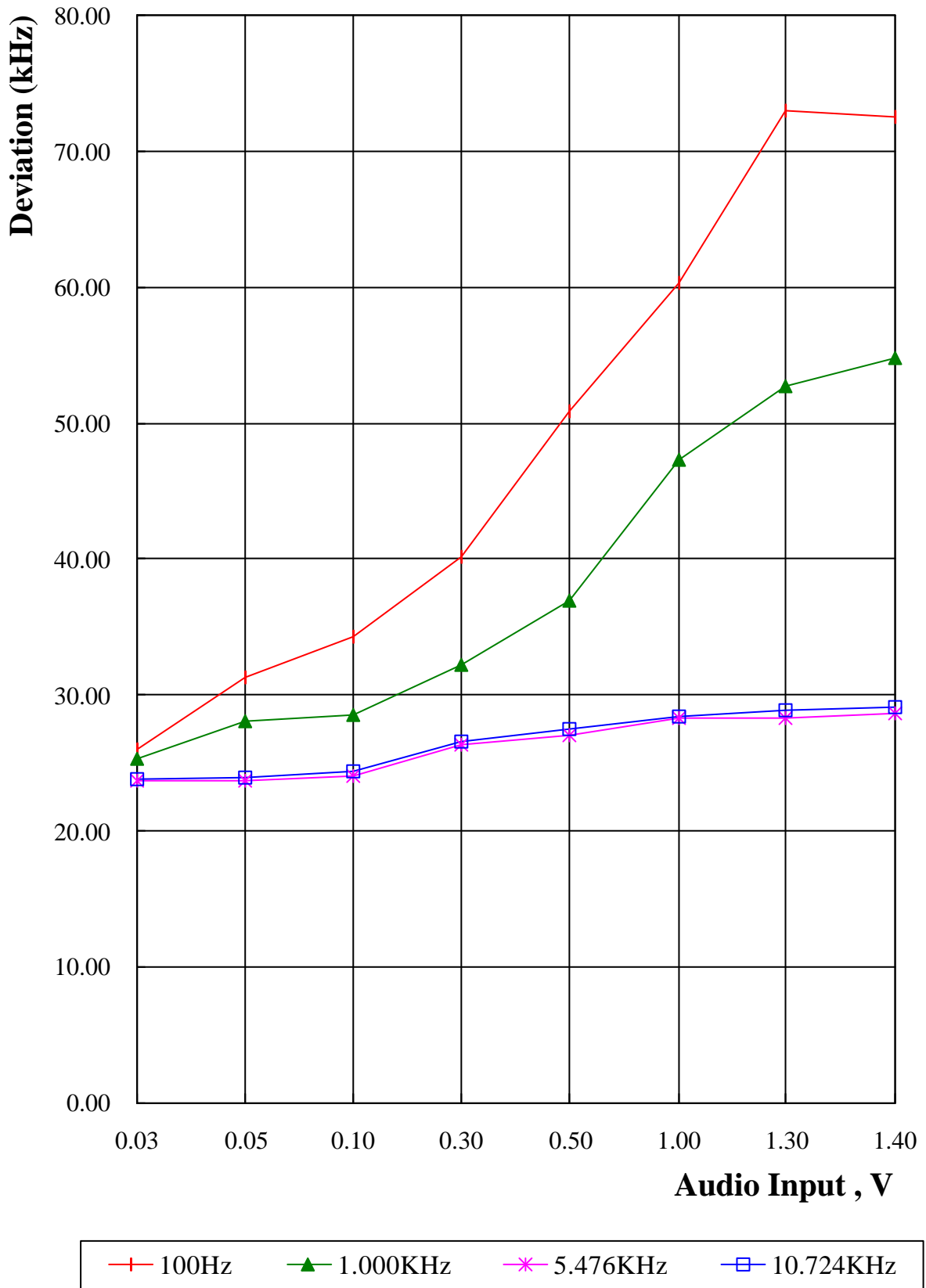
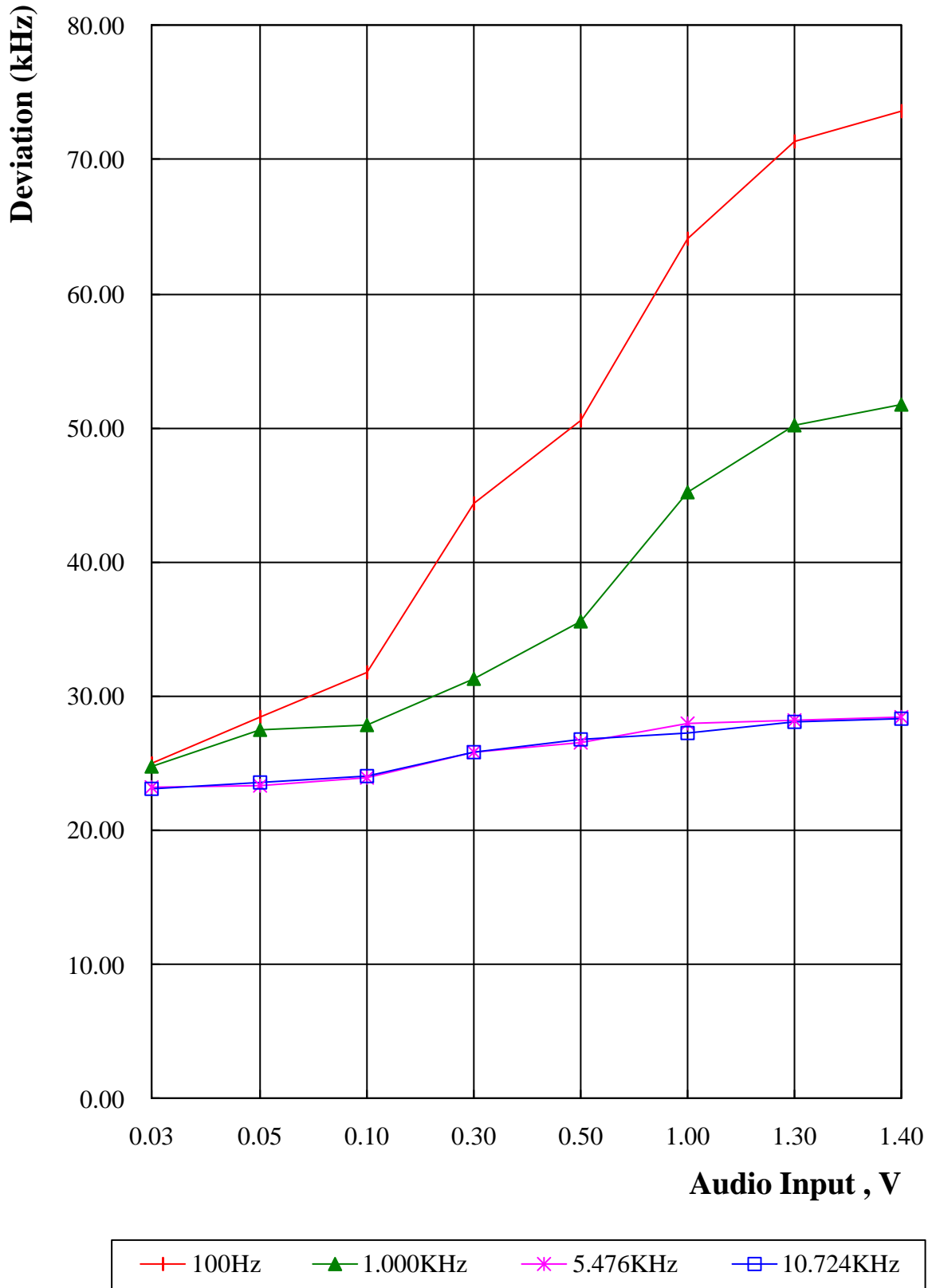

Chart 3.2 Modulation Limiting Measurement Positive



Chapter 4 Occupied Bandwidth Measurement

4.1 Rules and Specification Limits

2.1049 (c) (1) : ANSI / TIA / EIA-603-1992, Paragraph 2.2.11.

74.861 (e) (3) : Any form of modulation may be used. A maximum deviation of ± 75 kHz is permitted when frequency modulation is employed.

74.861 (e) (5) : The operation bandwidth shall not exceed 200kHz.

4.2 Test Configuration & List of Test Instruments

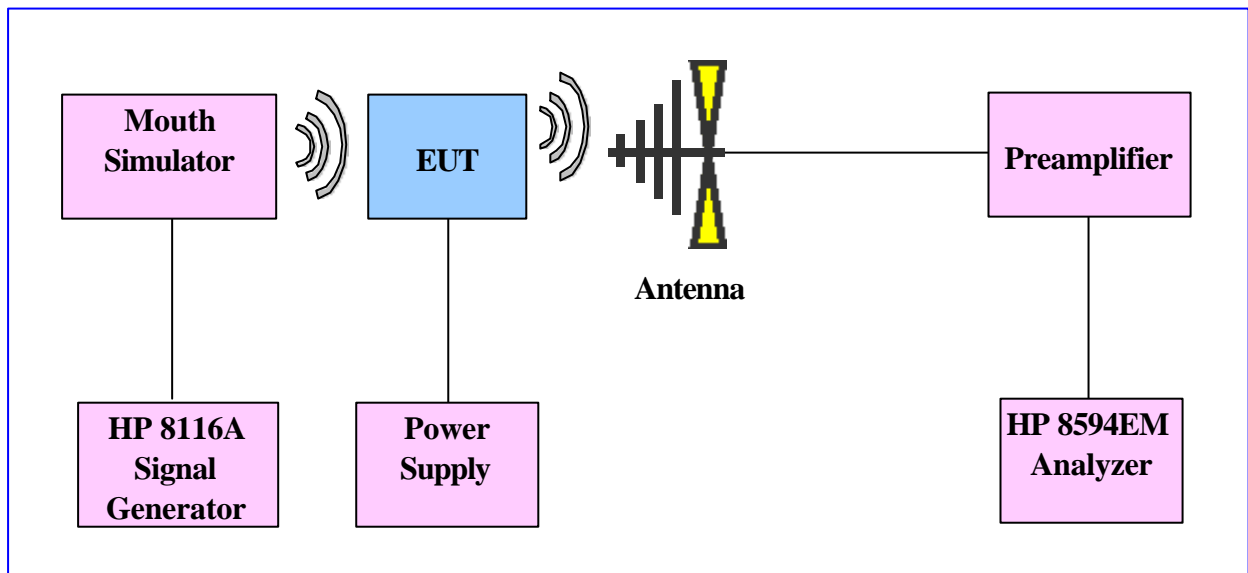

List of test Instrument :

<u>Instrument Name</u>	<u>Model No.</u>	<u>Brand</u>	<u>Input Impedance</u>
Spectrum Analyzer (9K~1.8GHz)	8594EM	HP	50
Preamplifier (30MHz~1GHz)	TRC001	TRC	50
Signal Generator 50 MHz	HP8116A	HP	50
Bi-log Antenna	CBL6141A	SCHAFFNER	50
B&K	Mouth Simulator	4227	50

4.3 Measurement Procedure

1. Connect the EUT as Section 4.2 .
2. Plot the unmodulated chart shows on spectrum.
3. Set the output of the signal generator to 100Hz, 1kHz, 5.476kHz and 10.724kHz. Increase the amplitude of the signal, while monitoring the modulation meter. Until modulation is max. measure the bandwidth under 26 dB compared to the unmodulated fundamental carrier peak level of the modulated signal displayed on the spectrum analyzer.
4. The occupied bandwidth was measured as follow pages.

4.4 Measurement Result

The occupied bandwidth's plot is presented on following pager, which illustrates compliance with the rules.

Calculation of Necessary Bandwidth (Bn)

$$B_n = 2M + 2D$$

$$M = \text{Max. Modulation Frequency} = 10.724 \text{ kHz}$$

$$D = \text{Peak Frequency Deviation} = 73.630 \text{ kHz (Chart 3-1)}$$

$$K = 1$$

$$B_n = 168.708 \text{ kHz}$$

Unmodulation

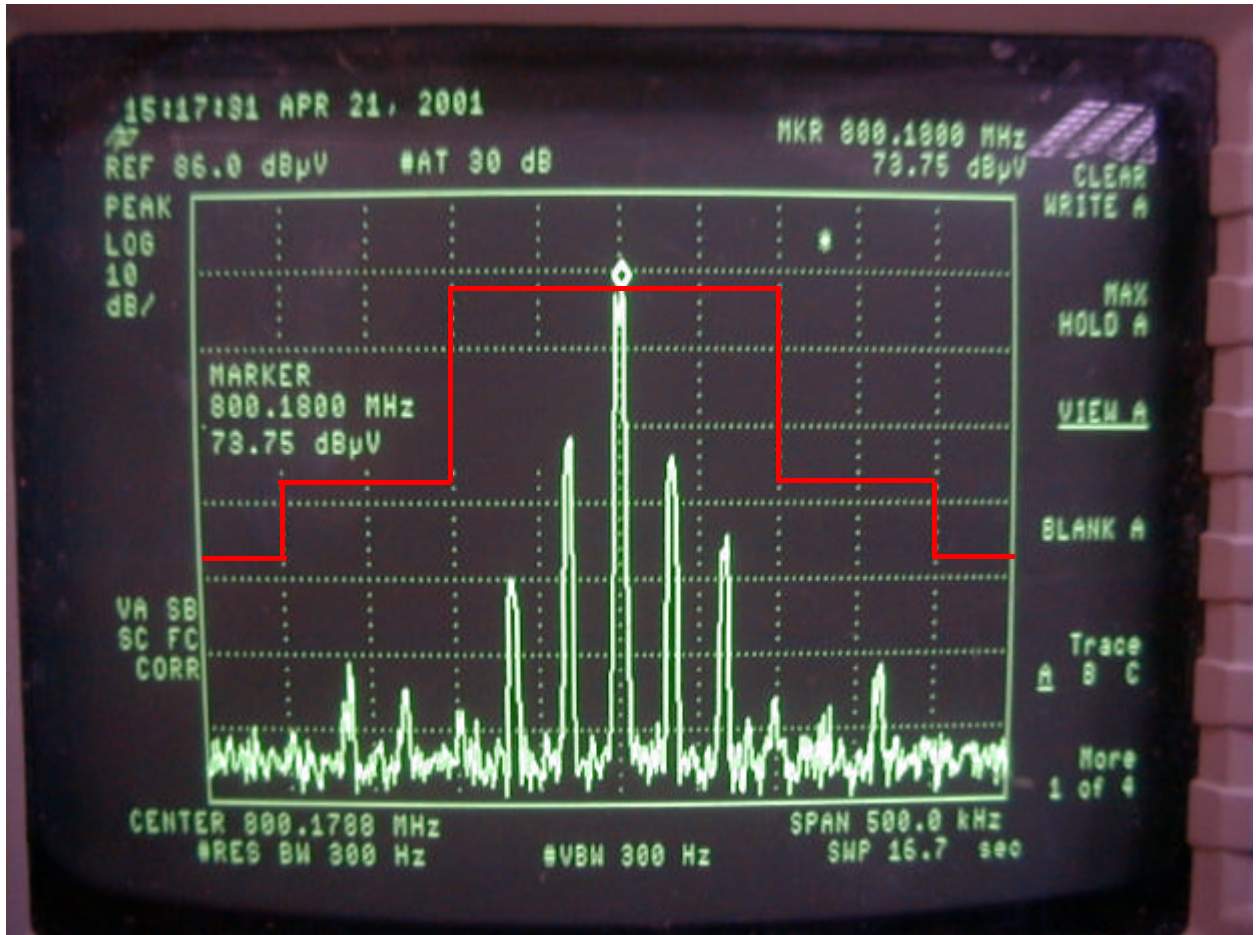

100Hz

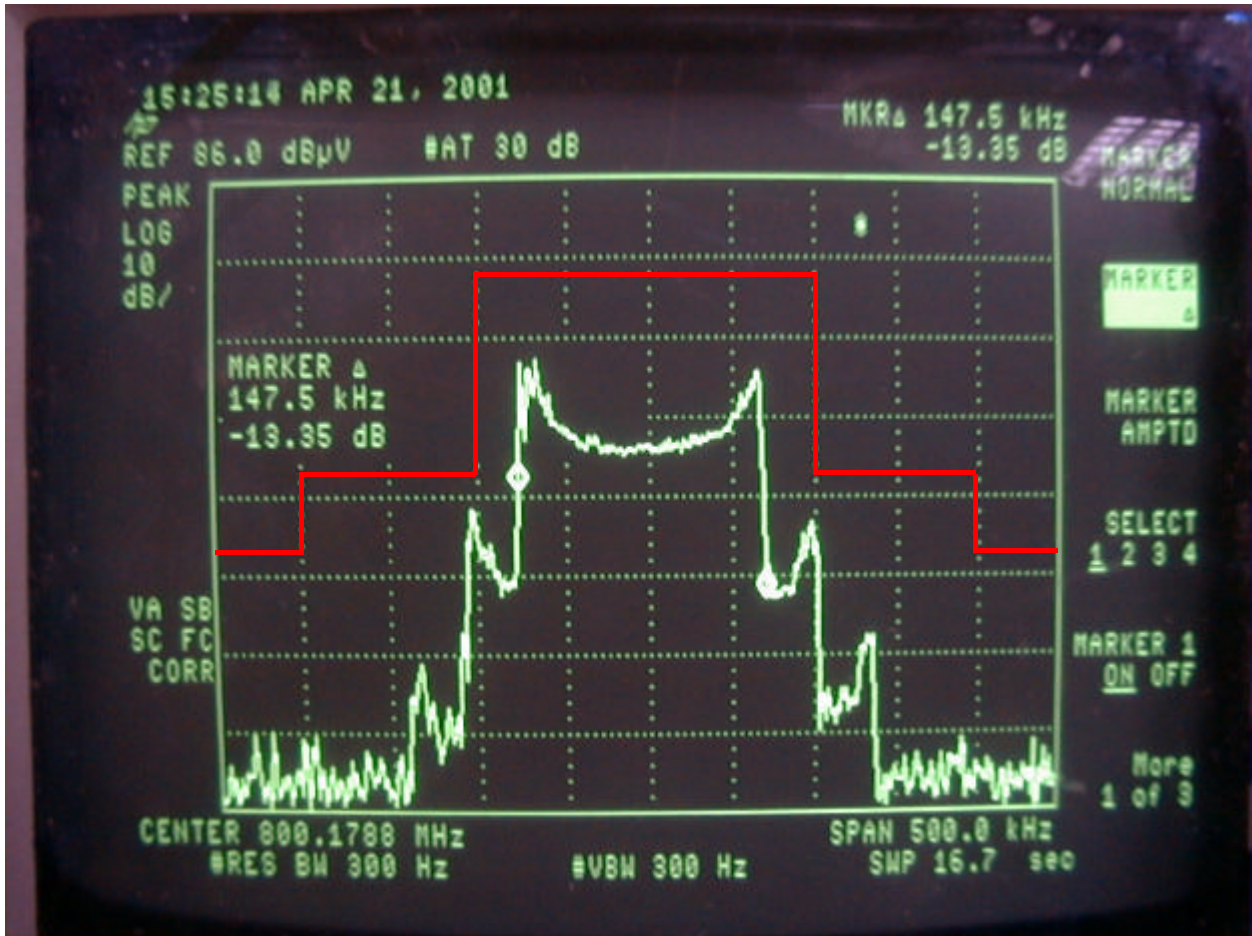

1KHz

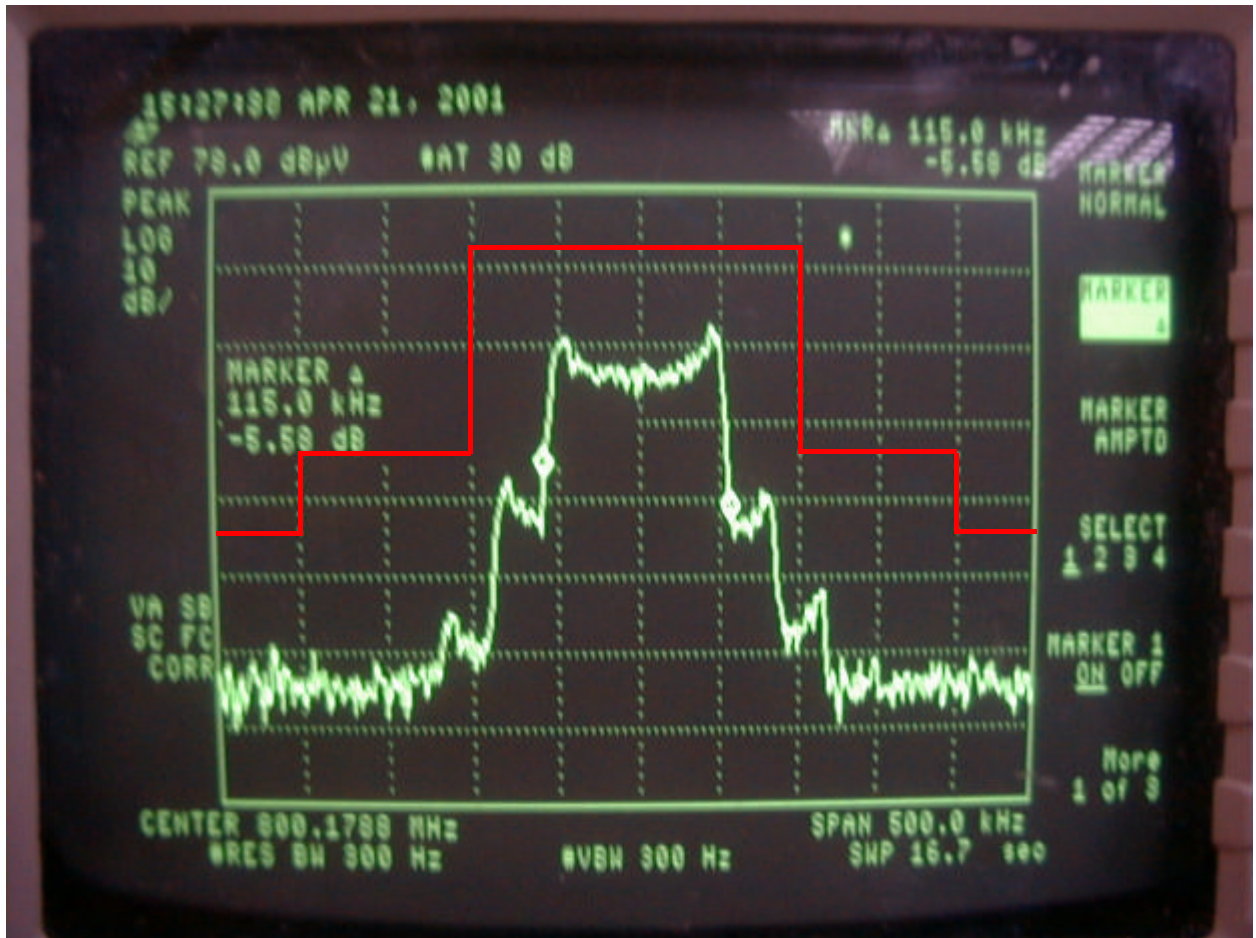

5.476KHz

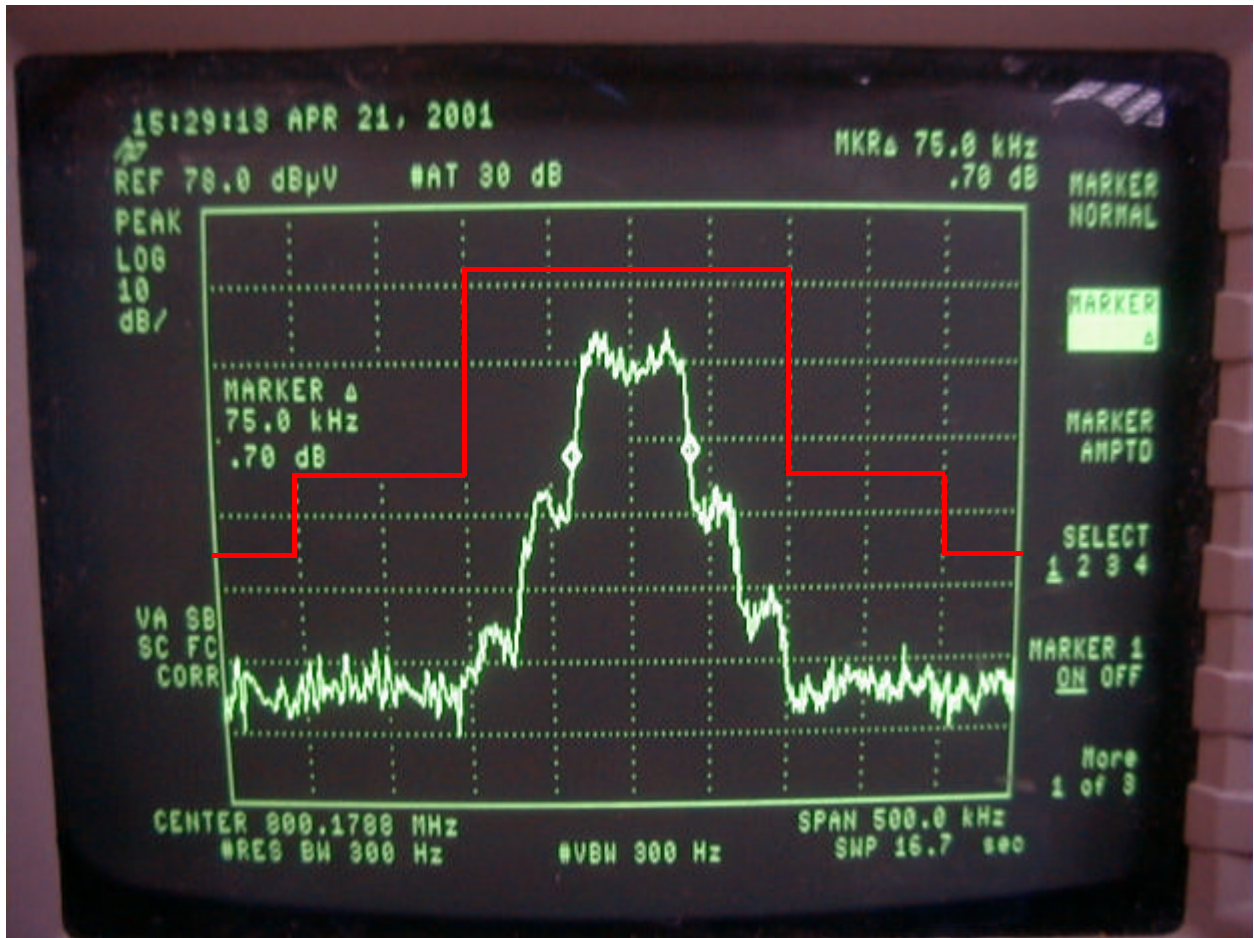

10.724KHz

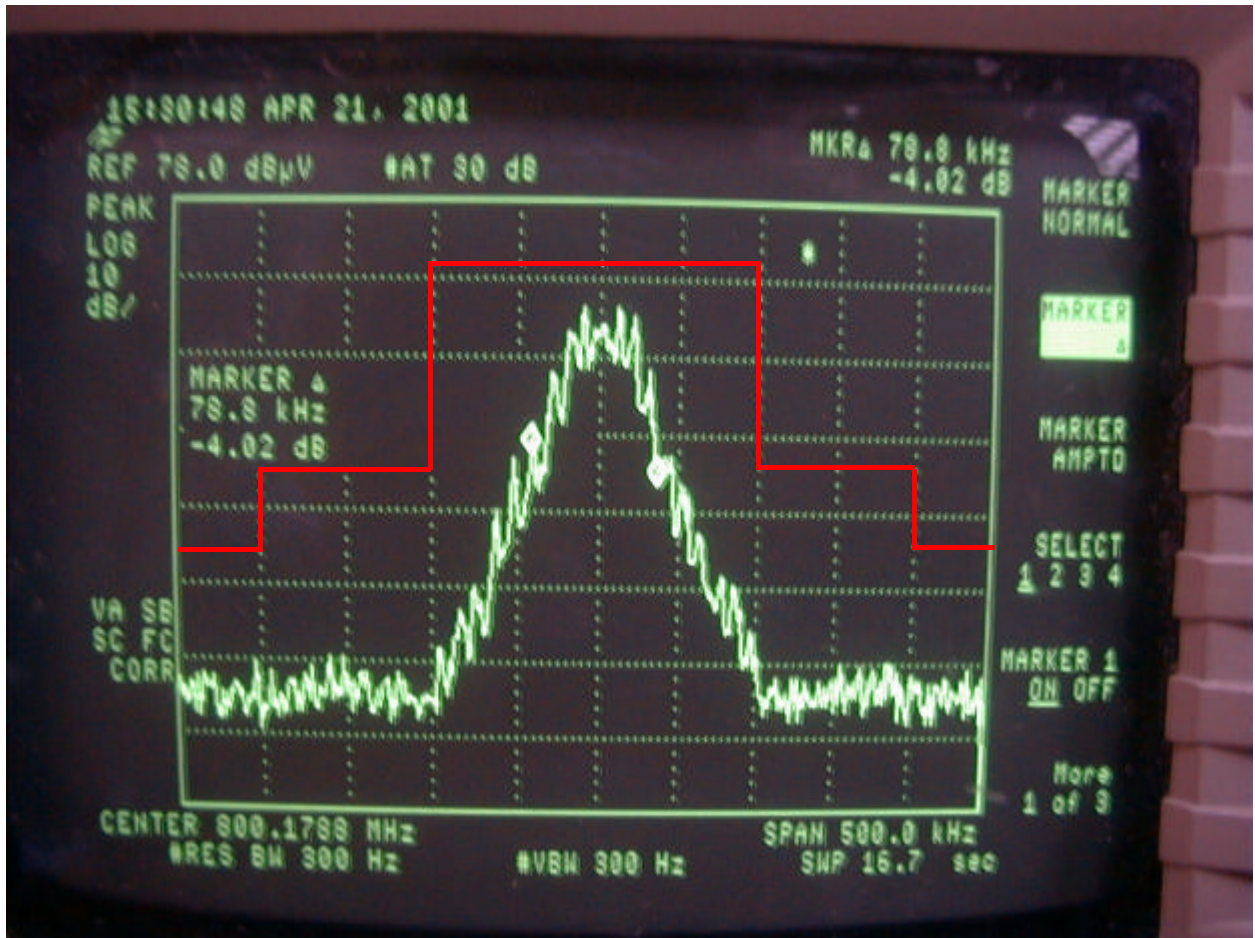

Chapter 5 Field Strength of Spurious Radiation Measurement

5.1 Rules and Specification Limits

2.1053 (a) : ANSI/ TIA/ EIA-603-1992, Paragraph 2.2.12

Measurements shall be made to detect spurious emissions that may be radiated directly from the cabinet, control circuits, Power leads, or intermediate circuit elements under normal conditions of installation and operation.

74.861(e) (6) (iii) :

Spurious and harmonics must be at least $43 + 10 \log (\text{Output Power})$ below the Carrier peak

2.1057 :

In all measurements set forth , the spectrum should be investigated from the lowest radio frequency generated in the equipment up to at least the 10th harmonic of the carrier frequency.

5.2 Measurement Condition & Setup

Pretest : The EUT is placed in a anechoic chamber, and scan from 30MHz to 1GHz. This is done to ensure the radiation exactly emits form the EUT.

Final test : Final radiation measurements is made on a **3 - meter, anechoic chamber**. The EUT is placed on a nonconductive table, which is 0.8m height, the top surface is 1.0 x 1.5 meter. All the placement is according to ANSI C63.4 - 1992.

The spectrum is examined from 30 MHz to 18 GHz measured by HP spectrum.

The SCHAFFNER and EMCO whole range Antenna is used to measure frequency from 30 MHz to 18 GHz. The final test is used the spectrum HP 8546A, HP 85460A and 8564E.

Measure more than six top marked frequencies generated form pretest by computer step by step at each frequency. The EUT is rotated 360 degrees, and antenna is raised and lowered from 1 to 4 meter to find the maximum emission levels. The antenna is used with both horizontal and vertical polarization.

Appropriated preamplifier which is made by TRC is used for improving sensitivity and precautions is taken to avoid overloading .The spectrum analyzer's 6dB bandwidth is set to 120 KHz, and the EUT is measured at quasi-peak mode.

If the emission is close to the frequency band of ambient, the tester will recheck the data and the corrected data will be written in the test data sheet. If the emission is just within the ambient, the data from anechoic will be taken as the final data.

The actual field intensity in decibels referenced to 1 micro volt per meter (dB μ V/m) is determined by algebraically adding the measured reading in dB μ V, the antenna factor (dB) and cable loss (dB) at the appropriate frequency.

(1) Band of Frequency: (30M Hz ~ 1G Hz)

$$FI_a \text{ (dB}\mu\text{V/m)} = FI_r \text{ (dB}\mu\text{V)} - \text{Corrected (dB)}$$

$$\text{Corrected (dB)} = AF(\text{dB}) + CL \text{ (dB)} - \text{Amplifier Gain}$$

FI_a : Actual Field Intensity

FI_r : Reading of the Field Intensity

AF : Antenna Factor

CL : Cable Loss

(2) Band of Frequency: (1G Hz ~ 18 G Hz)

$$FI_a \text{ (dB}\mu\text{V/m)} = FI_r \text{ (dB}\mu\text{V)} + AF \text{ (dB)} + CL(\text{dB})$$

FI_a : Actual Field Intensity

FI_r : Reading of the Field Intensity

AF : Antenna Factor

CL : Cable Loss

5.3 List of Measurement Instruments

Instrument Name	Model No.	Brand	Serial No.	<u>Calibration Date</u>	
				Last time	Next time
EMI Receiver	8546A	H P	3520A00242	10/01/00	10/01/01
RF Filter Section	85460A	H P	3448A00217	10/01/00	10/01/01
Bi-log Antenna	CBL6141A	Schaffner	4151	06/28/00	06/28/01
Switch/Control Unit (> 30MHz)	3488A	HP	N/A	11/20/00	11/20/01
Auto Switch Box (> 30MHz)	ASB-01	TRC	9904-01	11/20/00	11/20/01
Spectrum Analyzer	8564E	HP	US36433002	08/03/00	08/03/01
Microwave Preamplifier	83051A	HP	3232A00347	08/04/00	08/04/01
Horn Antenna	3115	EMCO	9704 – 5178	08/09/00	08/09/01
Anechoic Chamber & cable calibrated together				05/20/00	05/20/01

The level of confidence of 95%, the uncertainty of measurement of radiated emission is ± 4.96 dB.

5.4 Measurement Configuration

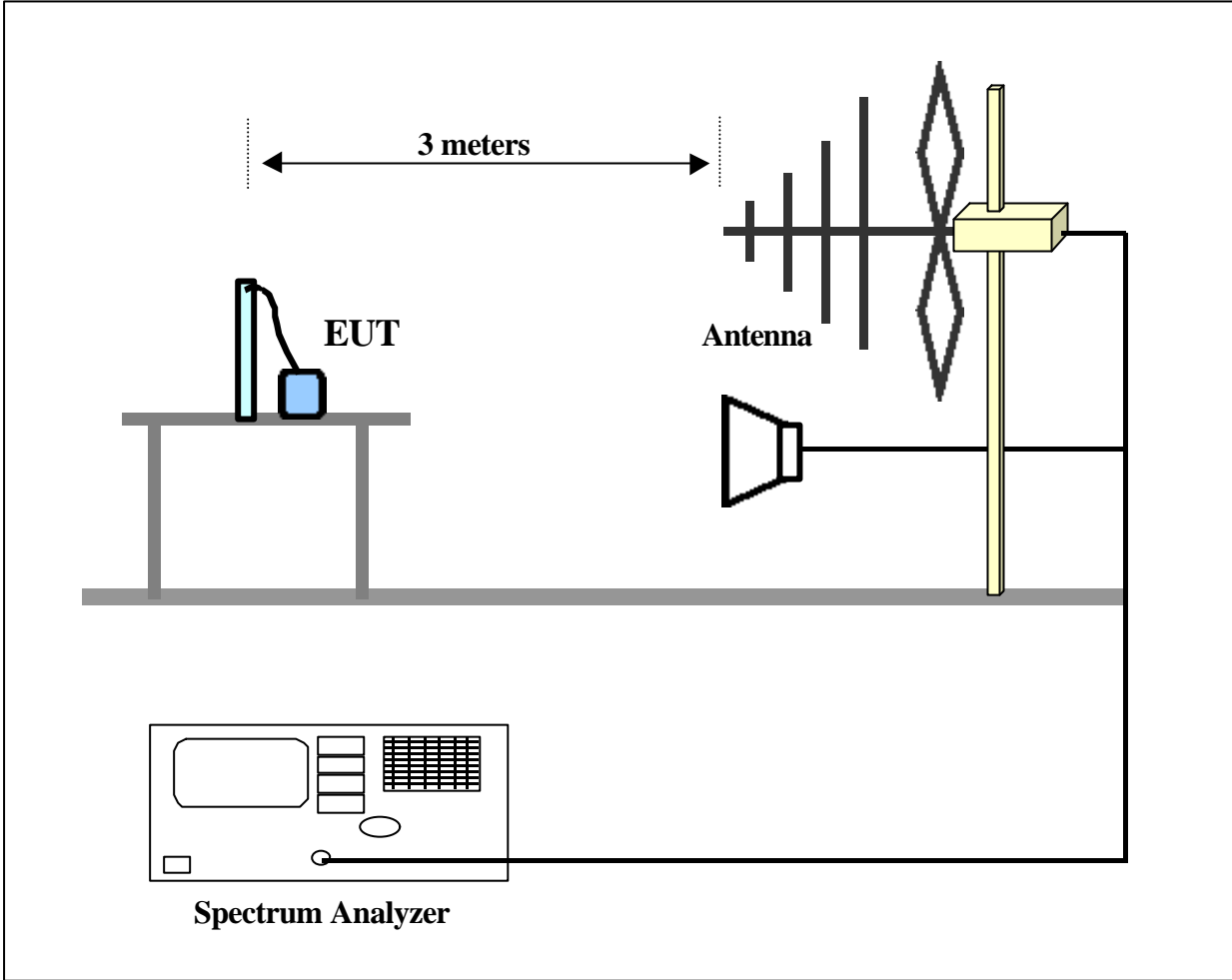

Test Configuration



5.5 Measurement Result:

(Test Frequency: 794.900MHz , Horizontal , 30 MHz ~ 1 GHz)

Test Conditions:

Testing room : Temperature : 26 °C Humidity : 73 % RH

Testing site : Temperature : 31 °C Humidity : 75 % RH

<i>Frequency</i>	<i>Reading Amplitude</i>	<i>Ant. Height</i>	<i>Table</i>	<i>Correction Factors</i>	<i>Corrected Amplitude</i>	<i>Limit</i>	<i>Margin</i>
MHz	dBμV	m	degree	dB/m	dBμV/m	dBμV/m	dB
198.726	31.78	1.00	18	-13.32	45.10	84.38	-39.28
397.450	22.64	1.00	41	-19.59	42.23	84.38	-39.28
596.174	21.38	1.00	80	-23.26	44.64	84.38	-39.74

Note:

1. Margin = Amplitude – limit, *if margin is minus means under limit.*
2. Corrected Amplitude = Reading Amplitude – Correction Factors
3. Correction factor = Antenna factor + (Cable Loss – Amplitude Gain)
4. Attenuation required = 43 + 10 log (0.787549 mW) = 11.96
 Limit = 96.34 – (11.96) = 84.38

Measurement Result:

(Test Frequency: 794.900MHz , Horizontal , 1GHz ~ 18GHz)

Radiated Emission				Correction Factors	Corrected Amplitude (dBμV/m)	FCC Class B (3 m)	
Frequency (GHz)	Amplitude (dBμV/m)	Ant. H. (cm)	Table (°)	(dB)		Limit (dBμV/m)	Margin (dB)
1.587	70.97	1.00	264	-8.67	62.30	84.38	-22.08
2.378	58.30	1.00	157	-8.67	49.63	84.38	-34.75
2.573	56.14	1.00	68	-6.84	49.30	84.38	-35.08
2.768	61.81	1.00	150	-6.84	54.97	84.38	-29.41
2.984	75.81	1.00	304	-6.84	68.97	84.38	-15.41
5.963	40.75	1.00	115	9.72	50.47	84.38	-33.91

Note:

1. Margin = Corrected – Limit.
2. Peak Amplitude + Correction Factor = Corrected

Radiated Emission Test Result:

(Test Frequency: 794.900MHz , Vertical , 30MHz ~ 1GHz)

<i>Frequency</i>	<i>Reading Amplitude</i>	<i>Ant. Height</i>	<i>Table</i>	<i>Correction Factors</i>	<i>Corrected Amplitude</i>	<i>Limit</i>	<i>Margin</i>
MHz	dBμV	m	degree	dB/m	dBμV/m	dBμV/m	dB

198.726	27.72	3.95	146	-13.54	41.26	84.38	-43.12
397.450	20.42	2.43	94	-19.14	39.56	84.38	-43.12
596.174	19.54	1.00	150	-23.53	43.07	84.38	-41.31

Radiated Emission Test Result:

(Test Frequency: 794.900MHz , Vertical , 1GHz ~ 18GHz)

<i>Radiated Emission</i>				<i>Correction Factors</i>	<i>Corrected Amplitude</i> (dBμV/m)	<i>FCC Class B (3 m)</i>	
<i>Frequency</i> (GHz)	<i>Amplitude</i> (dBμV/m)	<i>Ant. H.</i> (cm)	<i>Table</i> (°)	(dB)		<i>Limit</i> (dBμV/m)	<i>Margin</i> (dB)
1.587	74.80	1.00	345	-8.67	66.13	84.38	-18.25
2.378	57.14	1.00	207	-8.67	48.47	84.38	-35.91
2.573	60.31	1.00	169	-6.84	53.47	84.38	-30.91
2.768	63.47	1.00	49	-6.84	56.63	84.38	-27.75
2.984	72.81	1.00	147	-6.84	65.97	84.38	-18.41
6.353	40.63	1.00	64	9.72	50.35	84.38	-34.03

Measurement Result:

(Test Frequency: 800.200MHz , Horizontal , 30MHz ~ 1GHz)

<i>Frequency</i>	<i>Reading Amplitude</i>	<i>Ant. Height</i>	<i>Table</i>	<i>Correction Factors</i>	<i>Corrected Amplitude</i>	<i>Limit</i>	<i>Margin</i>
MHz	dBμV	m	degree	dB/m	dBμV/m	dBμV/m	dB
200.051	39.03	1.00	15	-13.40	52.43	84.38	-31.95
400.100	30.16	2.45	12	-19.71	49.87	84.38	-31.95
600.149	24.61	1.00	73	-23.25	47.86	84.38	-36.52

Note:

1. Margin = Amplitude - limit, *if margin is minus means under limit.*
2. Corrected Amplitude = Reading Amplitude – Correction Factors
3. Correction factor = Antenna factor + (Cable Loss – Amplitude Gain)
4. Attenuation required = $43 + 10 \log (1.107331 \text{ mW}) = 13.44$
 Limit = $97.82 - (13.44) = 84.38$

Measurement Result:

(Test Frequency: 800.200MHz , Horizontal , 1GHz ~ 18GHz)

Radiated Emission				Correction Factors	Corrected Amplitude (dBμV/m)	FCC Class B (3 m)	
Frequency (GHz)	Amplitude (dBμV/m)	Ant. H. (cm)	Table (°)	(dB)		Limit (dBμV/m)	Margin (dB)
1.596	69.80	1.00	219	-8.67	61.13	84.38	-23.25
1.998	65.80	1.00	41	-8.67	57.13	84.38	-27.25
2.594	64.31	1.00	167	-6.84	57.47	84.38	-26.91
2.789	68.51	1.00	158	-6.84	61.67	84.38	-22.71
2.995	67.47	1.00	240	-6.84	60.63	84.38	-23.75
3.006	59.97	1.00	37	-6.84	53.13	84.38	-31.25
4.598	55.72	1.00	146	3.91	59.63	84.38	-24.75
5.205	48.08	1.00	22	9.72	57.80	84.38	-26.58

Radiated Emission Test Result:

(Test Frequency: 800.200MHz , Vertical , 30MHz ~ 1GHz)

<i>Frequency</i>	<i>Reading Amplitude</i>	<i>Ant. Height</i>	<i>Table</i>	<i>Correction Factors</i>	<i>Corrected Amplitude</i>	<i>Limit</i>	<i>Margin</i>
MHz	dBμV	m	degree	dB/m	dBμV/m	dBμV/m	dB
200.051	37.30	3.97	76	-13.64	50.94	84.38	-33.44
400.100	30.57	1.02	68	-19.24	49.81	84.38	-33.44
600.149	26.34	1.02	76	-23.56	49.90	84.38	-34.48

Radiated Emission Test Result:

(Test Frequency: 800.200MHz , Vertical , 1GHz ~ 18GHz)

Radiated Emission				Correction Factors	Corrected Amplitude (dBμV/m)	FCC Class B (3 m)	
Frequency (GHz)	Amplitude (dBμV/m)	Ant. H. (cm)	Table (°)	(dB)		Limit (dBμV/m)	Margin (dB)
1.596	71.30	1.00	208	-8.67	62.63	84.38	-21.75
1.998	68.64	1.00	319	-8.67	59.97	84.38	-24.41
2.594	66.47	1.00	27	-6.84	59.63	84.38	-24.75
2.789	68.97	1.00	149	-6.84	62.13	84.38	-22.25
2.995	66.47	1.00	66	-6.84	59.63	84.38	-24.75
3.006	63.47	1.00	9	-6.84	56.63	84.38	-27.75
4.598	59.72	1.00	135	3.91	63.63	84.38	-20.75
5.205	45.41	1.00	164	9.72	55.13	84.38	-29.25

Measurement Result:

(Test Frequency: 804.900MHz , Horizontal , 30MHz ~ 1GHz)

<i>Frequency</i>	<i>Reading Amplitude</i>	<i>Ant. Height</i>	<i>Table</i>	<i>Correction Factors</i>	<i>Corrected Amplitude</i>	<i>Limit</i>	<i>Margin</i>
MHz	dBμV	m	degree	dB/m	dBμV/m	dBμV/m	dB
201.227	28.79	1.00	62	-13.49	42.28	84.38	-42.10
402.452	25.11	1.00	94	-19.81	44.92	84.38	-42.10
603.677	26.20	1.00	103	-23.24	49.44	84.38	-34.94

Note:

1. Margin = Amplitude – limit, *if margin is minus means under limit.*
2. Corrected Amplitude = Reading Amplitude – Correction Factors
3. Correction factor = Antenna factor + (Cable Loss – Amplitude Gain)
4. Attenuation required = $43 + 10 \log (0.392896 \text{ mW}) = 8.94$
 Limit = $93.32 - (8.94) = 84.38$

Measurement Result:

(Test Frequency: 804.900MHz , Horizontal , 1GHz ~ 18GHz)

Radiated Emission				Correction Factors	Corrected Amplitude (dBμV/m)	FCC Class B (3 m)	
Frequency (GHz)	Amplitude (dBμV/m)	Ant. H. (cm)	Table (°)	(dB)		Limit (dBμV/m)	Margin (dB)
1.608	67.97	1.00	174	-8.67	59.30	84.38	-25.08
2.410	61.47	1.00	15	-6.84	54.63	84.38	-29.75
2.605	83.31	1.00	129	-6.84	76.47	84.38	-7.91
5.238	41.75	1.00	106	9.72	51.47	84.38	-32.91

Radiated Emission Test Result:

(Test Frequency: 804.900MHz , Vertical , 30MHz ~ 1GHz)

<i>Frequency</i>	<i>Reading Amplitude</i>	<i>Ant. Height</i>	<i>Table</i>	<i>Correction Factors</i>	<i>Corrected Amplitude</i>	<i>Limit</i>	<i>Margin</i>
MHz	dBμV	m	degree	dB/m	dBμV/m	dBμV/m	dB
201.227	25.92	3.95	13	-13.72	39.64	84.38	-44.74
402.452	20.28	1.00	55	-19.36	39.64	84.38	-44.74
603.677	24.00	1.00	153	-23.57	47.57	84.38	-36.81

Radiated Emission Test Result:

(Test Frequency: 804.900MHz , Vertical , 1GHz ~ 18GHz)

<i>Radiated Emission</i>				<i>Correction Factors</i>	<i>Corrected Amplitude</i> (dBμV/m)	<i>FCC Class B (3 m)</i>	
<i>Frequency</i> (GHz)	<i>Amplitude</i> (dBμV/m)	<i>Ant. H.</i> (cm)	<i>Table</i> (°)	(dB)		<i>Limit</i> (dBμV/m)	<i>Margin</i> (dB)

1.608	68.80	1.00	147	-8.67	60.13	84.38	-24.25
2.096	61.97	1.00	227	-8.67	53.30	84.38	-31.08
2.410	68.64	1.00	98	-8.67	59.97	84.38	-24.41
2.605	81.14	1.00	106	-6.84	74.30	84.38	-10.08
5.238	40.75	1.00	57	9.72	50.47	84.38	-33.91

Chapter 6 Frequency Stability Tolerance Measurement

6.1 Rules and Specification Limits

2.1055, ANSI/ TIA/ EIA-603-1992, Paragraph 2.2.2 .

74.861(e)(4): The frequency tolerance of the transmitter shall be 0.005 percent.

6.2 Measurement Condition & Setup with Temperature Variation

1. Place the EUT in the chamber, powered in its normal operation.
2. Set the temperature of the chamber -30 degree Centigrade. Allow the equipment to stabilize at that temperature.
3. Measured the carrier frequency using preamplifier and frequency counter.
4. Repeated procedures 1 to 3 from -20 to 50 degree Centigrade at intervals of 10 degree.

6.3 List of Measurement Instruments with Temperature Variation List of test Instrument :

<u>Instrument Name</u>	<u>Model No.</u>	<u>Brand</u>	<u>Remark</u>
Spectrum Analyzer	8591A	H P	1.8GHz
Temperature Chamber	THS-MV2	King Son	
Near field Probe	7405-901	EMCO	
Power Supply	GPR-6030	Good Will	
Auto Transformer	Powerstat	Supprior Elec. Co.	

6.4 Measurement Configuration of Temperature Variation Test:

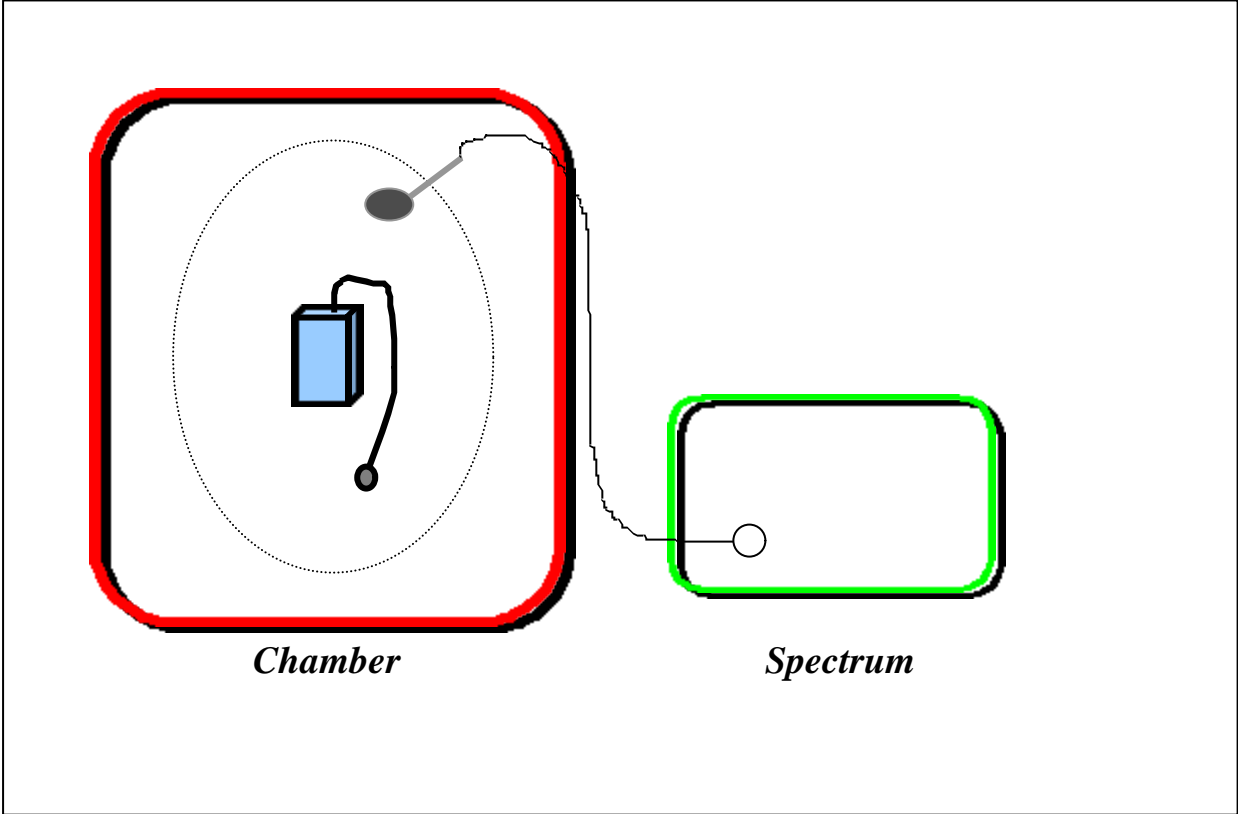

6.5 Measurement Result with Temperature Variation

A plot and table is presented which illustrates compliance with the rule where the center frequency is 800.200MHz.

Temperature Variation Table

<i>Temperature (Centigrade)</i>	<i>Frequency (MHz)</i>	<i>Tolerance (MHz)</i>
-30	800.188848	800.159990 ~ 800.240010
-25	800.188807	800.159990 ~ 800.240010
-20	800.188752	800.159990 ~ 800.240010
-15	800.188903	800.159990 ~ 800.240010
-10	800.189061	800.159990 ~ 800.240010
-5	800.189336	800.159990 ~ 800.240010
0	800.189891	800.159990 ~ 800.240010
5	800.192007	800.159990 ~ 800.240010
10	800.193431	800.159990 ~ 800.240010
15	800.195613	800.159990 ~ 800.240010
20	800.195273	800.159990 ~ 800.240010
25	800.195587	800.159990 ~ 800.240010
30	800.199557	800.159990 ~ 800.240010
35	800.199706	800.159990 ~ 800.240010
40	800.200038	800.159990 ~ 800.240010
45	800.200573	800.159990 ~ 800.240010
50	800.201437	800.159990 ~ 800.240010

Temperatuer Variation Vs. Frequency Chart

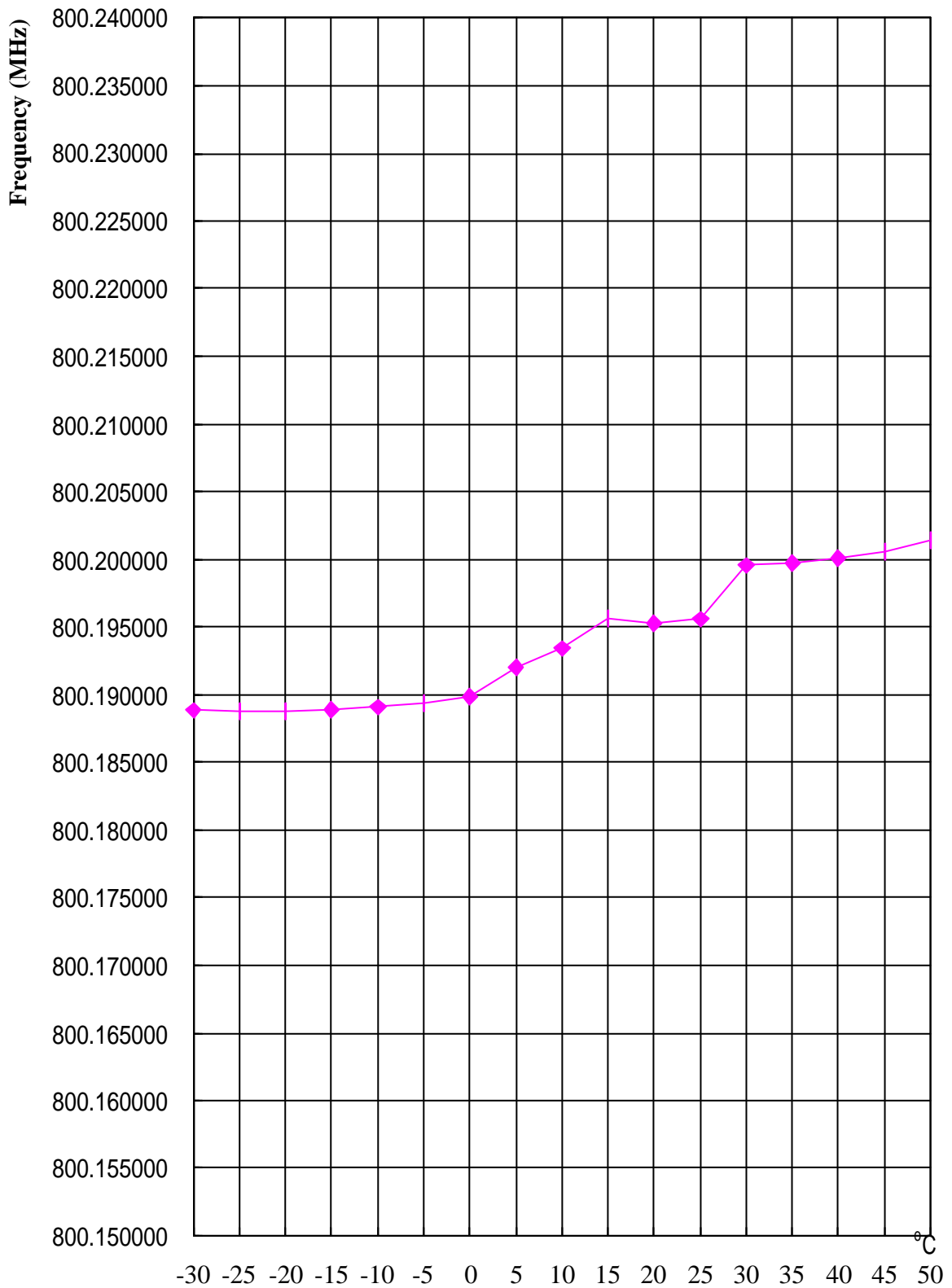

6.6 Measurement Condition & Setup with Voltage Variation

1. Attached the power line of the power supply to the battery position of the EUT.
2. Tuned the output power level to battery end point, 85 %, 100%, 115% of the normal operation power of EUT.
3. Recorded the frequency with a frequency counter.

6.7 List of Test Instrument :

<u>Instrument Name</u>	<u>Model No.</u>	<u>Brand</u>	<u>Remark</u>
Spectrum Analyzer	8591A	H P	1.8GHz
Temperature Chamber	THS-MV2	King Son	
Near field Probe	7405-901	EMCO	
Power Supply	GPR-6030	Good Will	
Auto Transformer	Powerstat	Supprior Elec. Co.	

6.8 Configuration of Voltage Variation Test :

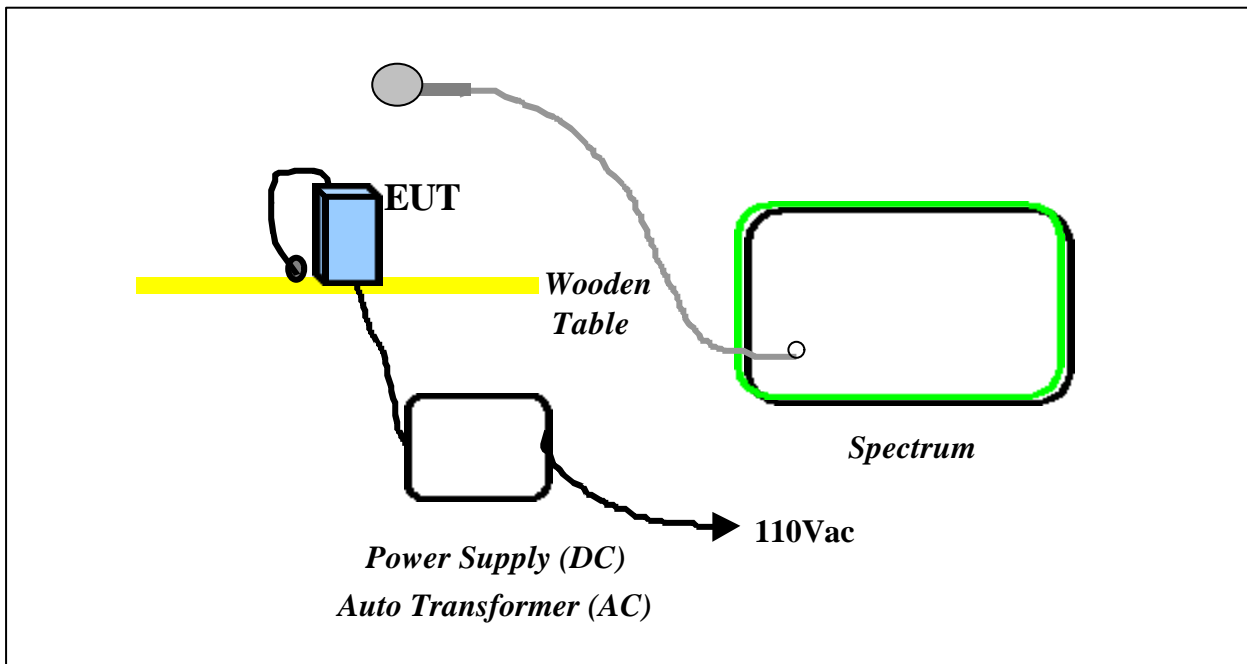

6.9 Measurement Result with Voltage Variation

Frequency Stability of Voltage Variation Measurement Table

<i>Supply Voltage (Volt)</i>	<i>Frequency (MHz)</i>	<i>Tolerance (MHz)</i>
7.65 (85%)	800.195304	800.159990 ~ 800.240010
9 (100%)	800.195552	800.159990 ~ 800.240010
10.35 (115%)	800.196973	800.159990 ~ 800.240010
Endpoint-Voltage: 3.40 V		

Voltage Variation Vs. Frequency Chart

