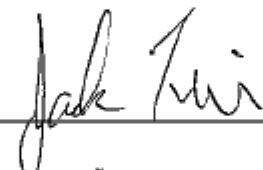
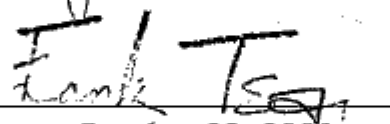

Report No.	S0774553	
Specifications	FCC Part 74 – Certification	
Test Method	ANSI C63.4 1992	
Applicant address	23, Lane 2, Jing Wu Road, Taichung, Taiwan, R.O.C.	
Applicant	Sekaku Electron Industry Co., Ltd.	
Items tested	Wireless Microphone	
Model No.	PEM-500T (Sample # S07553)	
Results	Compliance (As detailed within this report)	
Date	08/22/2001 (month / day / year) (Sample received)	
	10/08/2001 (month / day / year) (Test)	
Prepared by		Project Engineer
Authorized by		General Manager (Frank Tsai)
Issue date	October 22, 2001	(month / day / year)
Modifications	None	
Tested by	Training Research Co., Ltd.	
Office at	2, Lane 194, Huan-Ho Street, Hsichih, Taipei Hsien 221, Taiwan	
Anechoic Chamber at	2, Lane 194, Huan-Ho Street, Hsichih, Taipei Hsien 221, Taiwan	

Conditions of issue:

- (1) This test report shall not be reproduced except in full, without written approval of TRC. And the test result contained within this report only relate to the sample submitted for testing.
- (2) This report must not be used by the client to claim product endorsement by NVLAP or nay agency of U.S. Government.

★ **FCC ID : H38PEM-500T**

Contents

CHAPTER 0 APPLICATION FOR CERTIFICATION4

CHAPTER 1 GENERAL5

 1.1 INTRODUCTION.....5

 1.2 DESCRIPTION OF SUPPORT EQUIPMENT5

 1.3 CONFIGURATION OF TEST SETUP6

 1.4 LOCATION OF THE MEASUREMENT SITE.....7

 1.5 GENERAL TEST CONDITION.....7

CHAPTER 2 CONDUCTED EMISSION TEST8

 2.1 TEST CONDITION AND SETUP.....8

 2.2 LIST OF TEST INSTRUMENT8

 2.3 CONDUCTED TEST PLACEMENT: (PHOTOGRAPHS).....9

 2.4 CONDUCTED EMISSION TEST RESULT.....10

CHAPTER 3 POWER OUTPUT MEASUREMENT13

 3.1 RULES AND SPECIFICATION LIMITS.....13

 3.2 TEST CONDITION AND SETUP.....13

 3.4 MEASUREMENT RESULT16

CHAPTER 4 MODULATION CHARACTERISTICS MEASUREMENT19

 4.1 RULES AND SPECIFICATION LIMITS.....19

 4.2 TEST CONFIGURATION & LIST OF TEST INSTRUMENTS.....19

 4.3 LIST OF TEST INSTRUMENT.....20

 4.4 FREQUENCY RESPONSE OF AUDIO MODULATION CIRCUIT AND
 LOW PASS FILTER MEASUREMENT CONDITION & SETUP.....20

 4.5 MODULATION LIMITING MEASUREMENT CONDITION & SETUP.....22

CHAPTER 5 OCCUPIED BANDWIDTH MEASUREMENT.....25

5.1 RULES AND SPECIFICATION LIMITS25
5.2 TEST CONFIGURATION & LIST OF TEST INSTRUMENTS25
5.3 LIST OF TEST INSTRUMENT25
5.4 MEASUREMENT PROCEDURE.....26
5.5 MEASUREMENT RESULT26

CHAPTER 6 FIELD STRENGTH OF SPURIOUS RADIATION MEASUREMENT32

6.1 RULES AND SPECIFICATION LIMITS32
6.2 MEASUREMENT CONDITION & SETUP.....32
6.3 LIST OF MEASUREMENT INSTRUMENTS.....35
6.4 MEASUREMENT RESULT:.....36

CHAPTER 7 FREQUENCY STABILITY TOLERANCE MEASUREMENT42

7.1 RULES AND SPECIFICATION LIMITS42
7.2 MEASUREMENT CONDITION & SETUP WITH TEMPERATURE VARIATION.....42
7.3 LIST OF MEASUREMENT INSTRUMENTS WITH TEMPERATURE VARIATION LIST OF TEST INSTRUMENT.....42
7.4 MEASUREMENT CONFIGURATION OF TEMPERATURE VARIATION TEST:43
7.5 MEASUREMENT RESULT WITH TEMPERATURE VARIATION44
7.6 MEASUREMENT CONDITION & SETUP WITH VOLTAGE VARIATION.....46
7.7 CONFIGURATION OF VOLTAGE VARIATION TEST46
7.8 MEASUREMENT RESULT WITH VOLTAGE VARIATION47

Chapter 0 Application for Certification

- 74.861(e)(2)** : Transmitters may be either crystal controlled or frequency synthesized.
() crystal controlled (X) frequency synthesized
- 2.1033(c)(1)** : Sekaku Electron Industry Co., Ltd. – applicant and manufacturer
- 2.1033(c)(2)** : The equipment is a transmitter, wireless microphone
Model No.: PEM-500T
- 2.1033(c)(3)** : Quantity production is planned. See Exhibit C
- 2.1033(c)(4)** : Type of emission – F3E- FM Modulation
- 2.1033(c)(5)** : 100Hz ~ 15kHz
- 2.1033(c)(6)** : 15.6 mW
- 2.1033(c)(7)** : Specification of 250 mW is met by the equipment in the applicable
Part 74.861 (e)(1)(ii)
- 2.1033(c)(8)** : Final RF amplifier stage current : 400mA
- 2.1033(c)(9)** : Description follows
- 2.1033(c)(10)** : Complete circuit diagrams are included. No modification was made
- 2.1033(c)(11)** : See Exhibit A. Instruction sheet to user included
- 2.1033(c)(12)** : See Exhibit F.
- 2.1033(c)(13)** : N/A
- 2.1033(c)(14)** : Description follows.
- 2.1033(c)(15)** : N/A
- 2.1033(c)(16)** : N/A
- 2.1033(c)(17)** : N/A

Chapter 1 GENERAL

1.1 Introduction

The following measurement report is submitted on behalf of Sekaku Electron Industry Co., Ltd. in support of a wireless microphone certification in accordance with FCC Rules. 2.1031, 2.1046, 2.1047, 2.1049, 2.1053, 2.1055, 74.801 and 74.861.

Description of EUT:

EUT : WIRELESS MICROPHONE
Model No. : PEM-500T
Carrier Frequency Range : 694.3 ~ 704.3 MHz
RF Power Output : 15.6 mW
Supply Voltage : DC 15V
Supply Current : 400 mA
Frequency Response : 100Hz ~ 15KHz
Frequency Stability : 0.005%
Operating Temperature : - 30 to + 50 degree centigrade

Wireless microphone is a transmitter which operates in the frequency range of 694.3 ~ 704.3MHz. (Ch1: 694.300MHz, Ch9: 699.600MHz and Ch16: 704.300MHz tested) This microphone is worn by a performer and other participants in a program, filming, reporting ...etc.

1.2 Description of Support Equipment

Guitar Amplifier : **Dragon**
Model No. : GA-30
Power type : 110Vac, 60Hz
Power cord : Non-shield, 1.8m long
Microphone : **KOKA**
Model No. : DM-515
Power type : Dynamic
Data Cable : Non-shielded, 3m

1.3 Configuration of Test Setup

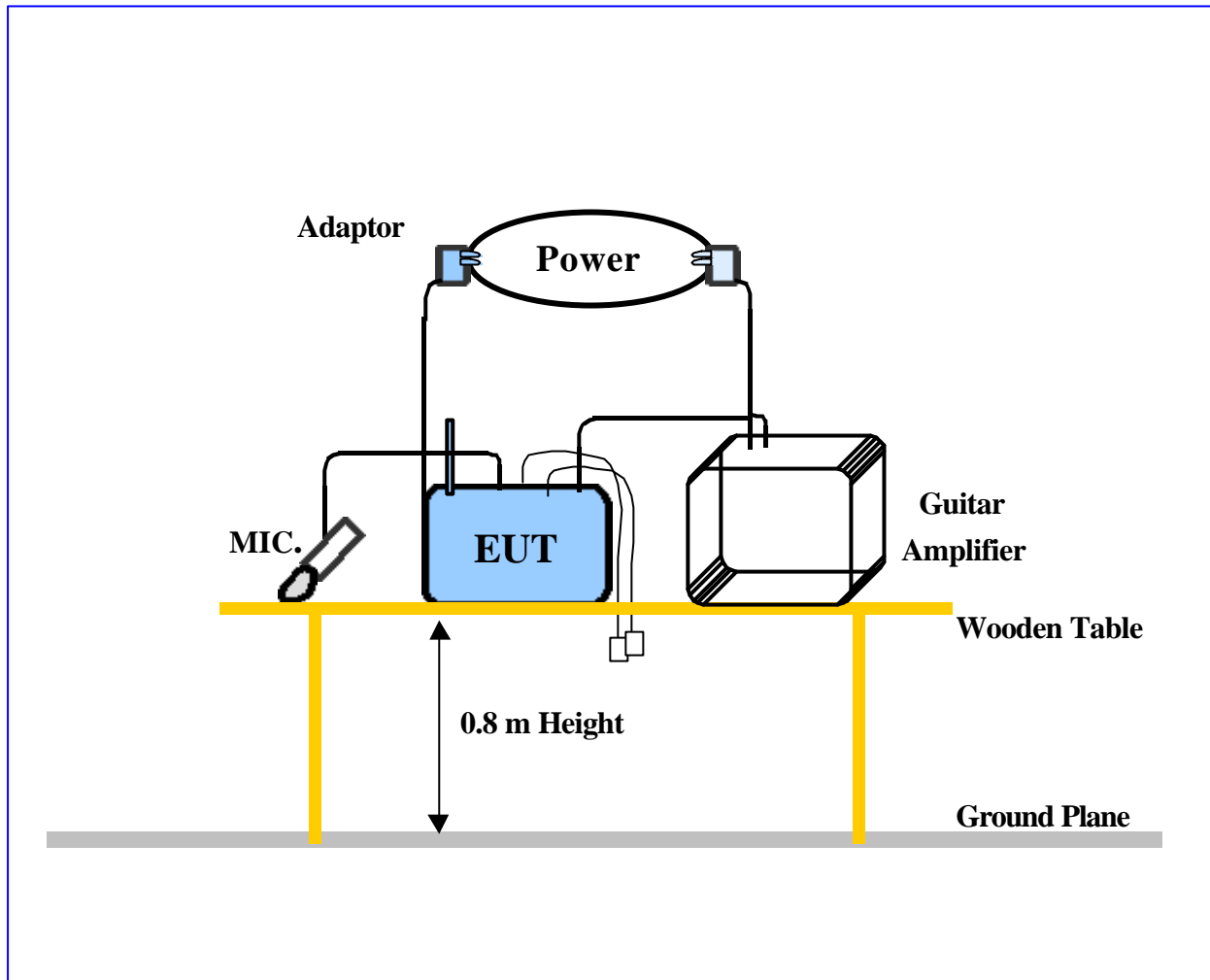

EUT:

- *Power Adaptor
 - Type: D41W150400-12/1
- *Power cable of Adaptor x 1
 - 186cm long, non-shielded, no ferrite core
- *Audio Cable x 2
 - 5m long, non-shielded, no ferrite core
- *MIC. Cable x 1
 - 3m long, non-shielded, no ferrite core

1.4 Location of the Measurement Site

The radiated emissions measurements required by the Rules were performed on the Three-meter, anechoic chamber at test site maintained by ***Training Research Co., Ltd.***, No. 2, Lane 194, Huan-Ho Street, Hsichih, Taipei Hsien 221, Taiwan. Complete description and measurement data have been placed on file with the Commission. The conducted power line Emissions tests were performed in a shielded enclosure also located at the above facility.

Training Research Co., Ltd. is listed by the FCC (Registration Number: 93906) as a facility available to do measurement work for others on a contract basis.

1.5 General Test Condition

The conditions under which the EUT operates were varied to determine their effect on the equipment's emission characteristics. The final configuration of the test system and the mode of operation used during these tests were chosen as that which produced the highest emission levels. However, only those conditions, which the EUT was considered likely to encounter in normal use were investigated.

Chapter 2 Conducted Emission Test

2.1 Test condition and setup

All the equipment is placed and setup according to the ANSI C63.4 - 1992.

The EUT is assembled on a wooden table, which is 80 cm high, is placed 40 cm from the back-wall, which is a vertical conducting plane. One LISN is for EUT, the other LISN is for support equipment. They are all placed on the conductive ground. The EUT's LISN connect a line switch box for selecting L1 or L2, then connect to a preamplifier and spectrum.

The spectrum scans from 450KHz to 30 MHz. Conducted emission levels are detected at maximum peak mode. But if the maximum peak mode failed, it will be measured by CISPR's quasi-peak detection mode.

While testing, there is the worst-emission plot printed at peak detection mode, and there are more than 6 highest emissions relative to limit recorded. The plot is kept as the original data, not included in test report.

2.2 List of test Instrument

<u>Instrument Name</u>	<u>Model No.</u>	<u>Brand</u>	<u>Serial No.</u>	<u>Calibration Date</u>	
				<u>Last time</u>	<u>Next time</u>
EMI Receiver	8546A	H P	3520A00242	06/29/01	06/29/02
RF Filter Section	85460A	H P	3448A00217	06/29/01	06/29/02
LISN (EUT)	LISN-01	TRC	9912-03,04	12/09/00	12/09/01
LISN (Support E.)	LISN-01	TRC	9912-05	01/04/01	01/04/02
Switch/Control Unit (< 30MHz)	3488A	HP	N/A	11/20/00	11/20/01
Auto Switch Box (< 30MHz)	ASB-01	TRC	9904-01	11/20/00	11/20/01

The level of confidence of 95%, the uncertainty of measurement of conducted emission is ± 2.4 dB.

2.3 Conducted Test Placement: (Photographs)

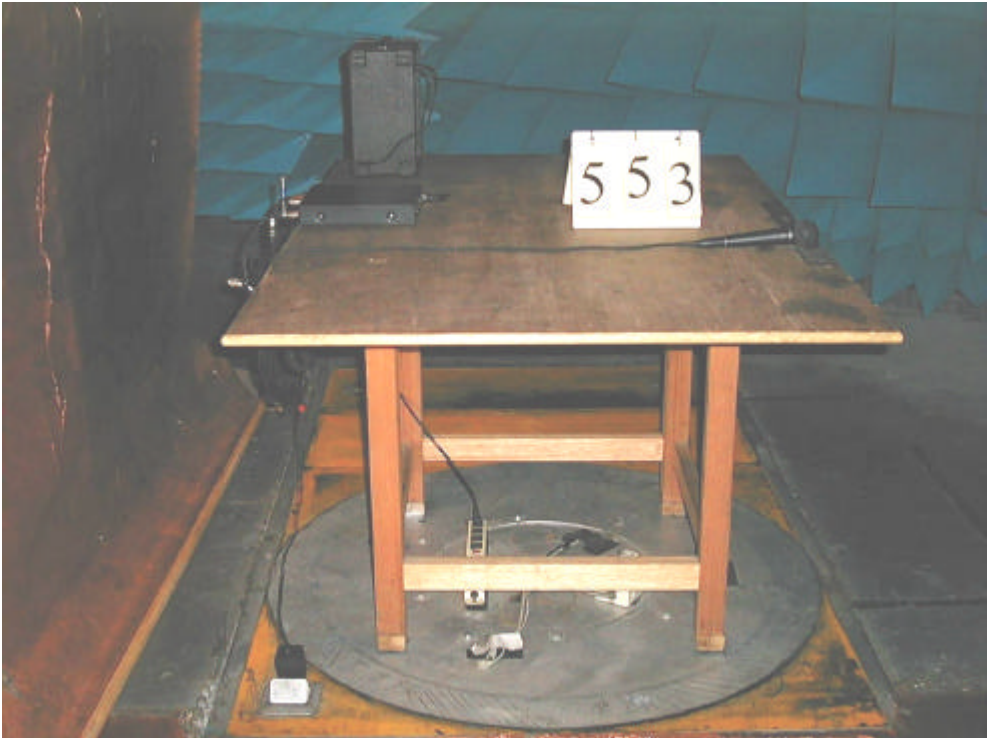

2.4 Conducted Emission Test Result

Testing room: Temperature : 25 ° C Humidity : 70 % RH Test mode: Channel 1

Line 1

Frequency (KHz)	READING AMPLITUDE			LIMIT		Margin (dB)
	Peak (dBmV/m)	Quasi- Peak (dBmV/m)	Average (dBmV/m)	Quasi- Peak (dBmV/m)	Average (dBmV/m)	
477.00	39.24	---	---	48.00	---	-8.76
496.00	39.75	---	---	48.00	---	-8.25
505.00	40.09	---	---	48.00	---	-7.91
524.00	40.29	---	---	48.00	---	-7.71
571.00	41.64	---	---	48.00	---	-6.36
593.00	41.27	---	---	48.00	---	-6.73
604.00	40.76	---	---	48.00	---	-7.24
645.00	37.82	---	---	48.00	---	-10.18
671.00	34.88	---	---	48.00	---	-13.12
709.00	28.76	---	---	48.00	---	-19.24

Line 2

Frequency (KHz)	READING AMPLITUDE			LIMIT		Margin (dB)
	Peak (dBmV/m)	Quasi- Peak (dBmV/m)	Average (dBmV/m)	Quasi- Peak (dBmV/m)	Average (dBmV/m)	
496.00	41.37	---	---	48.00	---	-6.63
518.00	42.61	---	---	48.00	---	-5.39
564.00	46.19	---	---	48.00	---	-1.81
597.00	48.42	7.31	---	48.00	---	-40.69
624.00	48.90	7.26	---	48.00	---	-40.74
671.00	47.40	---	---	48.00	---	-0.60
709.00	43.51	---	---	48.00	---	-4.49
749.00	39.07	---	---	48.00	---	-8.93
922.00	34.51	---	---	48.00	---	-13.49
966.00	34.51	---	---	48.00	---	-13.49

**The reading amplitudes are all under limit.*

Testing room: Temperature : 25 ° C Humidity : 70 % RH Test mode: Channel 9

Line 1

Frequency (KHz)	READING AMPLITUDE			LIMIT		Margin (dB)
	Peak (dBmV/m)	Quasi- Peak (dBmV/m)	Average (dBmV/m)	Quasi- Peak (dBmV/m)	Average (dBmV/m)	
452.00	38.93	---	---	48.00	---	-9.07
477.00	40.33	---	---	48.00	---	-7.67
502.00	40.77	---	---	48.00	---	-7.23
524.00	41.86	---	---	48.00	---	-6.14
545.00	42.47	---	---	48.00	---	-5.53
575.00	42.55	---	---	48.00	---	-5.45
586.00	41.97	---	---	48.00	---	-6.03
608.00	41.14	---	---	48.00	---	-6.86
637.00	38.65	---	---	48.00	---	-9.35
684.00	31.94	---	---	48.00	---	-16.06

Line 2

Frequency (KHz)	READING AMPLITUDE			LIMIT		Margin (dB)
	Peak (dBmV/m)	Quasi- Peak (dBmV/m)	Average (dBmV/m)	Quasi- Peak (dBmV/m)	Average (dBmV/m)	
457.00	43.27	---	---	48.00	---	-4.73
477.00	42.03	---	---	48.00	---	-5.97
512.00	43.10	---	---	48.00	---	-4.90
538.00	45.44	---	---	48.00	---	-2.56
560.00	47.63	---	---	48.00	---	-0.37
586.00	49.02	35.42	---	48.00	---	-12.58
620.00	49.60	35.51	---	48.00	---	-12.49
633.00	49.18	35.44	---	48.00	---	-12.56
654.00	47.72	---	---	48.00	---	-0.28
697.00	42.74	---	---	48.00	---	-5.26

**The reading amplitudes are all under limit.*

Testing room: Temperature : 27 ° C Humidity : 68 % RH Test mode: Channel 16

Line 1

Frequency (KHz)	READING AMPLITUDE			LIMIT		Margin (dB)
	Peak (dBmV/m)	Quasi- Peak (dBmV/m)	Average (dBmV/m)	Quasi- Peak (dBmV/m)	Average (dBmV/m)	
452.00	39.17	---	---	48.00	---	-8.83
477.00	40.15	---	---	48.00	---	-7.85
505.00	41.39	---	---	48.00	---	-6.61
530.00	41.75	---	---	48.00	---	-6.25
560.00	42.24	---	---	48.00	---	-5.76
571.00	42.47	---	---	48.00	---	-5.53
590.00	41.86	---	---	48.00	---	-6.14
608.00	40.86	---	---	48.00	---	-7.14
637.00	38.45	---	---	48.00	---	-9.55
654.00	36.36	---	---	48.00	---	-11.64

Line 2

Frequency (KHz)	READING AMPLITUDE			LIMIT		Margin (dB)
	Peak (dBmV/m)	Quasi- Peak (dBmV/m)	Average (dBmV/m)	Quasi- Peak (dBmV/m)	Average (dBmV/m)	
470.00	41.87	---	---	48.00	---	-6.13
505.00	42.76	---	---	48.00	---	-5.24
538.00	45.12	---	---	48.00	---	-2.88
579.00	48.60	28.36	---	48.00	---	-19.64
593.00	49.36	28.16	---	48.00	---	-19.84
612.00	49.66	27.80	---	48.00	---	-20.20
628.00	49.50	26.78	---	48.00	---	-21.22
645.00	48.67	25.47	---	48.00	---	-22.53
692.00	44.74	---	---	48.00	---	-3.26
719.00	41.76	---	---	48.00	---	-6.24

**The reading amplitudes are all under limit.*

Chapter 3 Power Output Measurement

3.1 Rules and Specification Limits

2.1046(a), ANSI/ TIA/ EIA-603-1992, Paragraph 2.2.1.

74.861 (e)(1) : The power of the measured unmodulated carrier power at output of the transmitter power amplifier (antenna input power) may not exceed the following:

1. 54 – 72, 76 – 88 and 174 – 216 MHz band 50 mW.
2. 470 – 608 and 614 – 806 MHz band 250 mW.

3.2 Test condition and setup

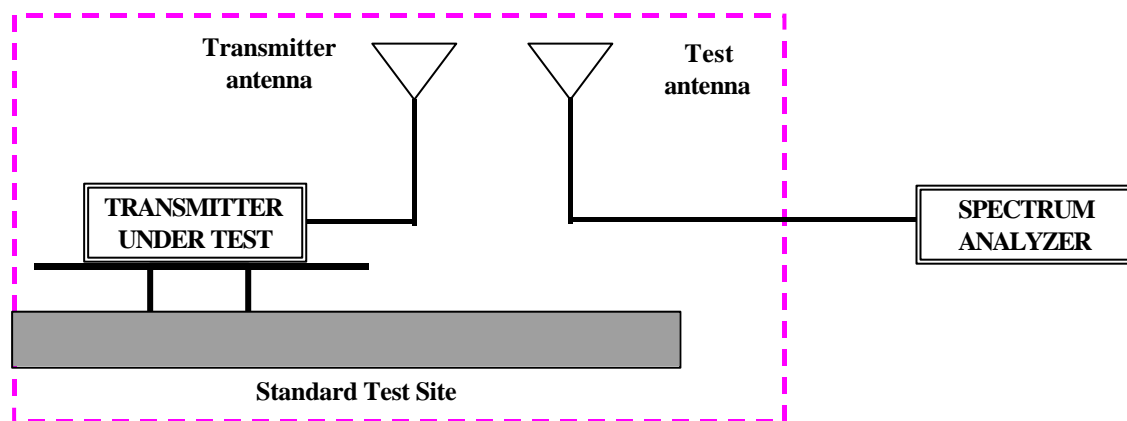

1. Measurement was made on anechoic chamber. The EUT system was placed on non-conductive turntable which is 0.8 meters height, top surface 1.0 X 1.5 meter. The EUT was placed in three direction of the space in order to obtain maximum emission.
2. Connect the equipment as illustrated. Place the transmitter to be tested on the turntable in the standard test site.
3. Raise and lower the test antenna from 1m to 4m with the transmitter facing the antenna and record the highest received signal.
4. Repeat step (3) for seven additional readings at 45 interval positions of the turn-table.

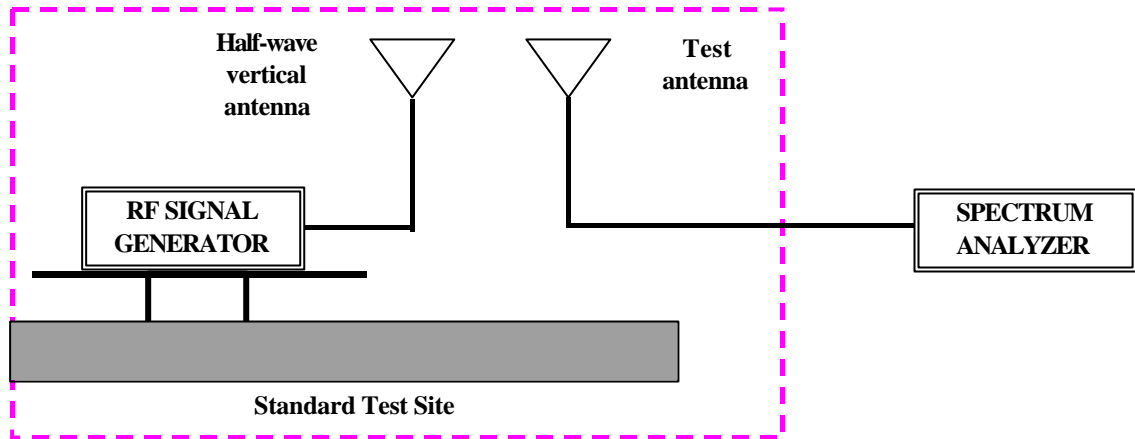

5. Replace the transmitter under test with a half-wave vertically polarized antenna. The center of the antenna should be at the same location as the transmitter under test. Connect the antenna to a signal generator with a known output and record value.

6. $FI_a(\text{dBm}) = FI_r(\text{dBm}) - \text{Corrected (dB)}$
 Corrected (dB) = $AF(\text{dB}) + [CL(\text{dB}) - \text{Amplitude Gain}]$
 FI_a : Actual Field Intensity
 FI_r : Reading of the Field Intensity
 AF : Antenna Factor
 CL : Cable Loss

7. The field intensity in Watt can then be determined by the following equation:

$$P \text{ (watt) } = FI^2 \text{ (Volt) } \times d^2 \text{ (meter) } / 49.2$$

P : Power in Watt

D : Measurement Distance (3 m)

3.3 List of test Instrument

Instrument Name	Model No.	Brand	Serial No.	Calibration Date	
				Last time	Next time
EMI Receiver	8546A	H P	3520A00242	06/29/01	06/29/02
RF Filter Section	85460A	H P	3448A00217	06/29/01	06/29/02
Bi-log Antenna	CBL6141A	Schaffner	4206	03/09/01	03/09/02
Switch/Control Unit (> 30MHz)	3488A	HP	N/A	11/20/00	11/20/01
Auto Switch Box (> 30MHz)	ASB-01	TRC	9904-01	11/20/00	11/20/01
Spectrum Analyzer	8564E	HP	US36433002	08/01/01	08/01/02
Microwave Preamplifier	83051A	HP	3232A00347	08/01/01	08/01/02
Horn Antenna	3115	EMCO	9704 – 5178	08/01/01	08/01/02
Anechoic Chamber (cable calibrated together)				05/20/01	05/20/02

The level of confidence of 95%, the uncertainty of measurement of radiated emission is ± 4.96 dB.

3.4 Measurement Result

(1) Frequency: 694.300 MHz

The maximum field measured is 11.92 dBm

$$FI \text{ (Volt)} = 10^{109.297/20} \times 10^{-6} = 0.291642 \text{ V}$$

$$FI \text{ (mW)} = (0.291642 \times 3)^2 / 49.2 = 15.558 \text{ mW}$$

Angle of Turn Table (°)	Spectrum Reading (dBm)	Corrected (dB)	Actually Value (dBm)	E. R. P. (mW)	Average (mW)
0°	15.39	-6.08	9.31	5.203	3.29
45°	17.76	-6.08	11.68	8.980	
90°	11.38	-6.08	5.30	2.067	
135°	12.74	-6.08	6.66	2.827	
180°	11.13	-6.08	5.05	1.951	
225°	9.50	-6.08	3.42	1.341	
270°	9.85	-6.08	3.77	1.453	
315°	12.16	-6.08	6.08	2.473	

(2) Frequency: 699.600 MHz

The maximum field measured is 9.74dBm

$$FI \text{ (Volt)} = 10^{107.117/20} \times 10^{-6} = 0.2269081 \text{ V}$$

$$FI \text{ (mW)} = (0.2269081 \times 3)^2 / 49.2 = 9.410 \text{ mW}$$

Angle of Turn Table (°)	Spectrum Reading (dBm)	Corrected (dB)	Actually Value (dBm)	E. R. P. (mW)	Average (mW)
0°	15.29	-6.10	9.19	5.061	2.77
45°	15.69	-6.10	9.59	5.550	
90°	9.75	-6.10	3.65	1.413	
135°	13.78	-6.10	7.68	3.575	
180°	11.70	-6.10	5.60	2.215	
225°	7.79	-6.10	1.69	0.900	
270°	10.17	-6.10	4.07	1.557	
315°	11.03	-6.10	4.93	1.898	

(3) Frequency: 704.300 MHz

The maximum field measured is 10.07 dBm

$$FI \text{ (Volt)} = 10^{107.447/20} \times 10^{-6} = 0.2356948 \text{ V}$$

$$FI \text{ (mW)} = (0.2356948 \times 3)^2 / 49.2 = 10.162 \text{ mW}$$

Angle of Turn Table (°)	Spectrum Reading (dBm)	Corrected (dB)	Actually Value (dB μ V/m)	E. R. P. (mW)	Average (mW)
0°	15.84	-6.16	9.68	5.666	2.86
45°	15.19	-6.16	9.03	4.878	
90°	11.40	-6.16	5.24	2.038	
135°	13.66	-6.16	7.50	3.430	
180°	9.57	-6.16	3.41	1.337	
225°	10.23	-6.16	4.07	1.557	
270°	10.21	-6.16	4.05	1.550	
315°	12.08	-6.16	5.92	2.384	

Chapter 4 Modulation Characteristics Measurement

4.1 Rules and Specification Limits

2.1047 (a), ANSI/ TIA/ EIA-603-1992, Paragraph 2.2.6.

Voice modulated communication equipment

2.1047 (b), ANSI/ TIA/ EIA-603-1992, Paragraph 2.2.3.

Equipment which employs modulation limiting

4.2 Test Configuration & List of Test Instruments

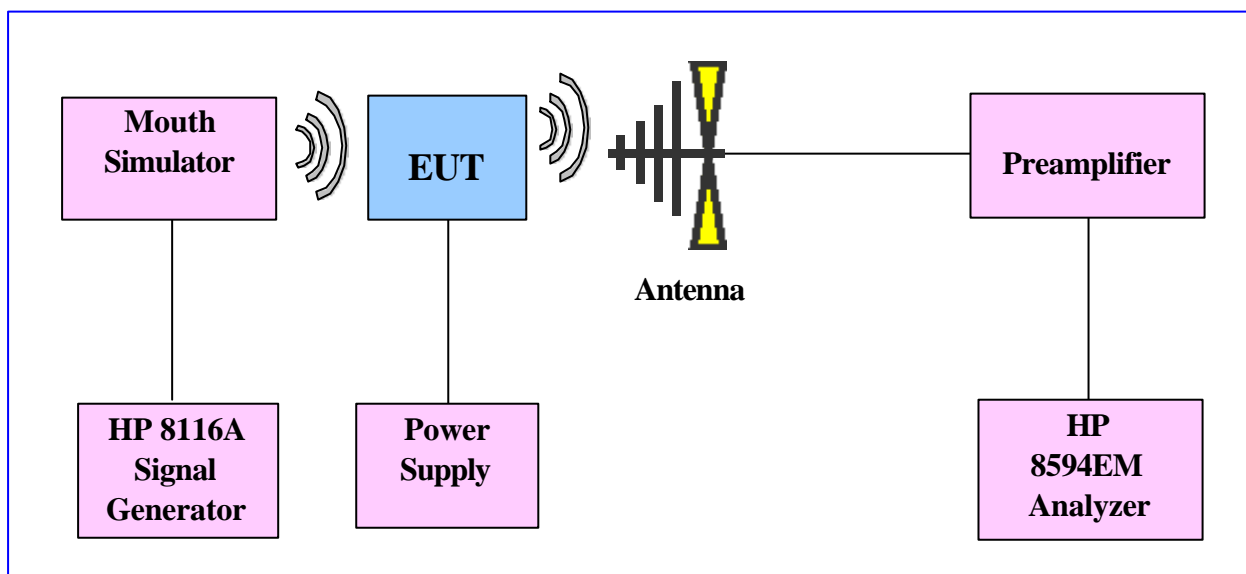

4.3 List of test instrument

<u>Manufacturer</u>	<u>Device</u>	<u>Model No.</u>	<u>Input Impedance</u>
HP	Dynamic Signal Analyzer	HP35660A	50
HP	Signal Generator 50 MHz	HP8116A	50
SCHAFFNER	Bi-log Antenna	CBL6141A	50
Farnell	Modulation Meter	AMM2000	50
TRC	Preamplifier	TRC001	50

4.4 Frequency Response of Audio Modulation Circuit and Low Pass Filter Measurement Condition & Setup

2.1047 (a)

1. The EUT and test equipment were set up as shown on the Section 4.2.
2. The Plus/Function generator was connected to the microphone of EUT, via an artificial mouth simulator.
3. The audio signal input was adjusted to obtain 50% modulation at 1 kHz.
4. With input levels held constant and below limiting at all frequencies, the generator was varied from 100 Hz to 51.3 kHz.
5. The response in dBm relative to 1kHz was then measured, using the HP 35660A Dynamic Signal Analyzer as follow page.

Number: 10

Update Rate: 5

Overlap: 0%

AVERAGE IN PROGRESS

Meas

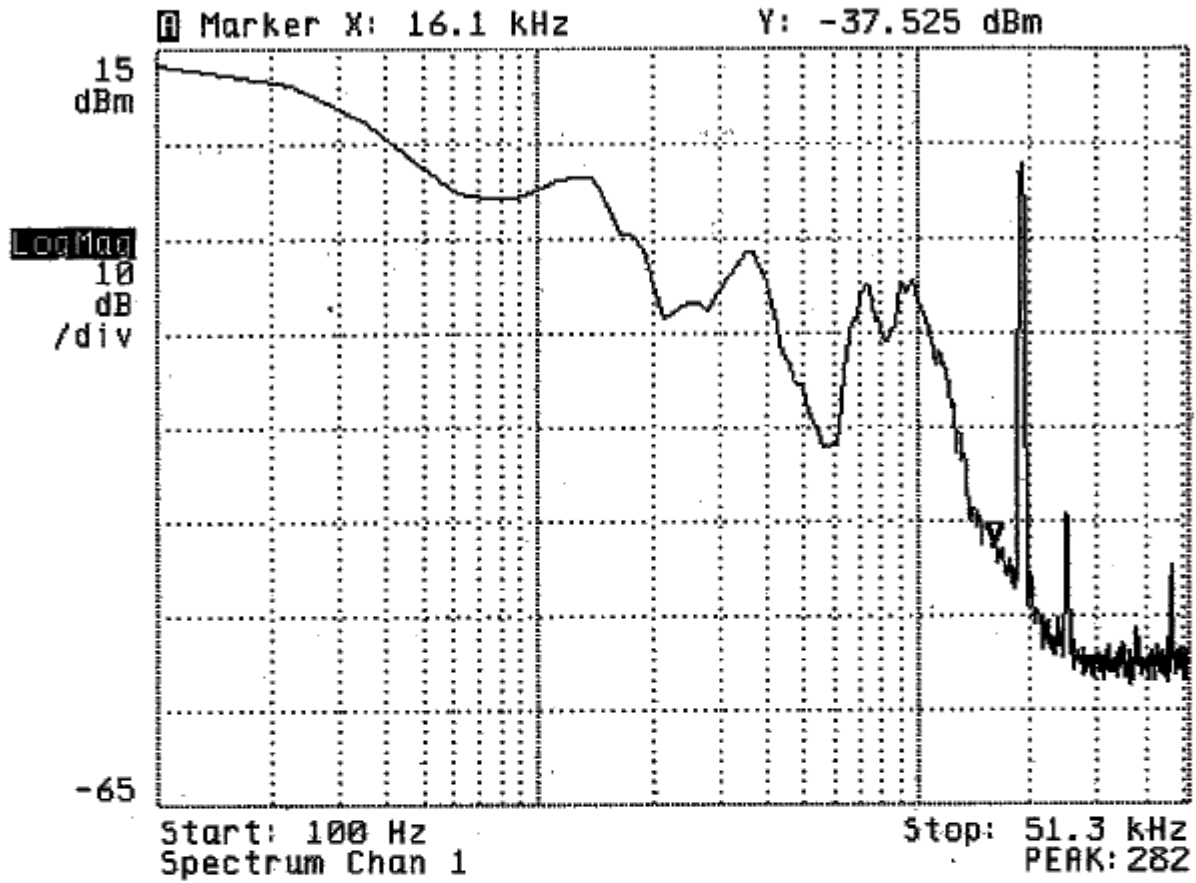

4.5 Modulation Limiting Measurement Condition & Setup

2.1047 (b)

1. The Plus/Function generator was connected to the microphone of EUT, via an artificial mouth simulator.
2. The modulation response was measured for each of four frequencies: 300Hz, 1kHz, 2.5kHz and 15kHz.
3. The input level was varied from 30% modulation to at least 20dB higher than the saturation point.
4. Measurements were performed for both negative and positive modulation and the respective results were recorded.
5. Measurement results as Chart 4.1 and 4.2

Chart 4.1 Modulation Limiting Measurement Negative

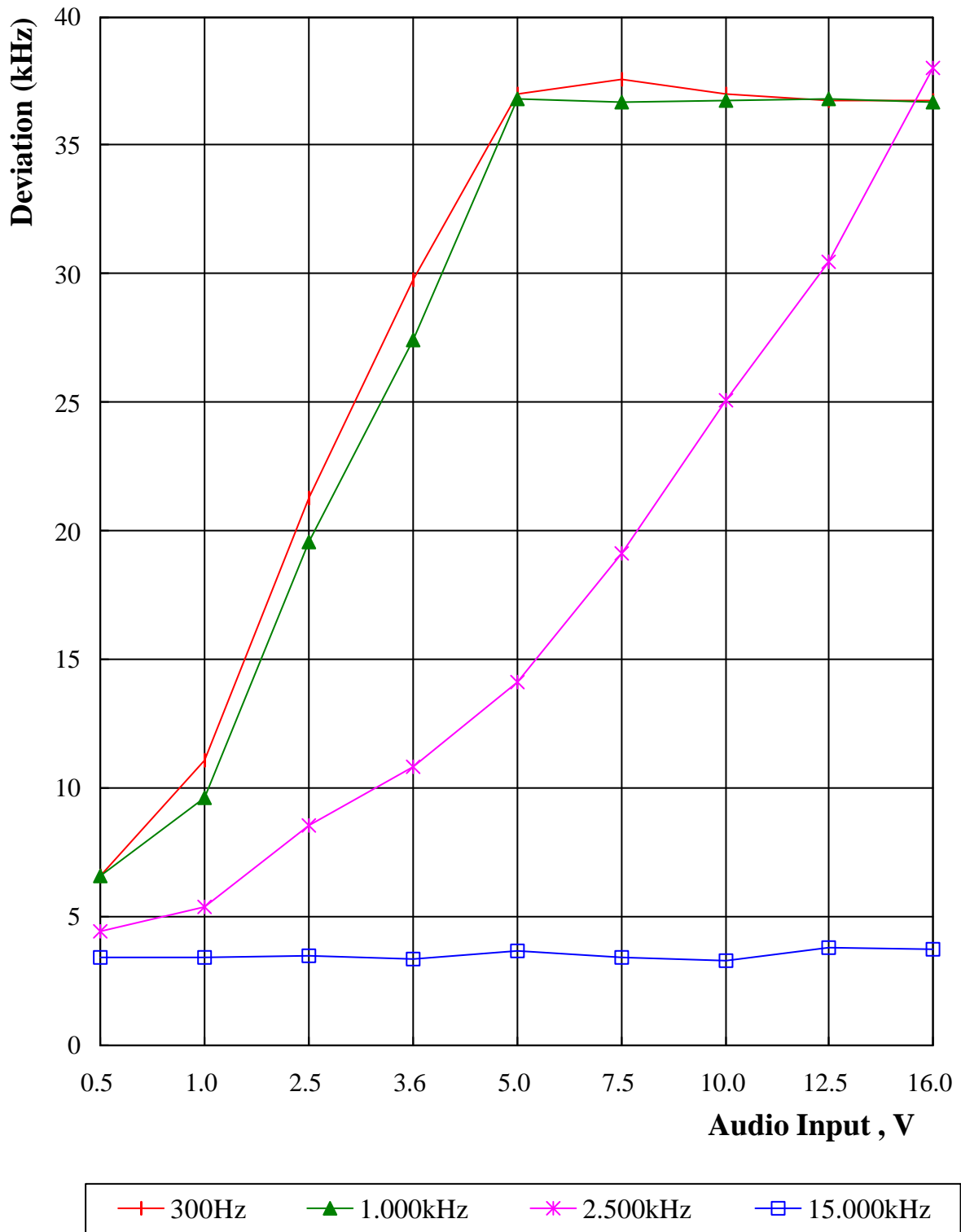
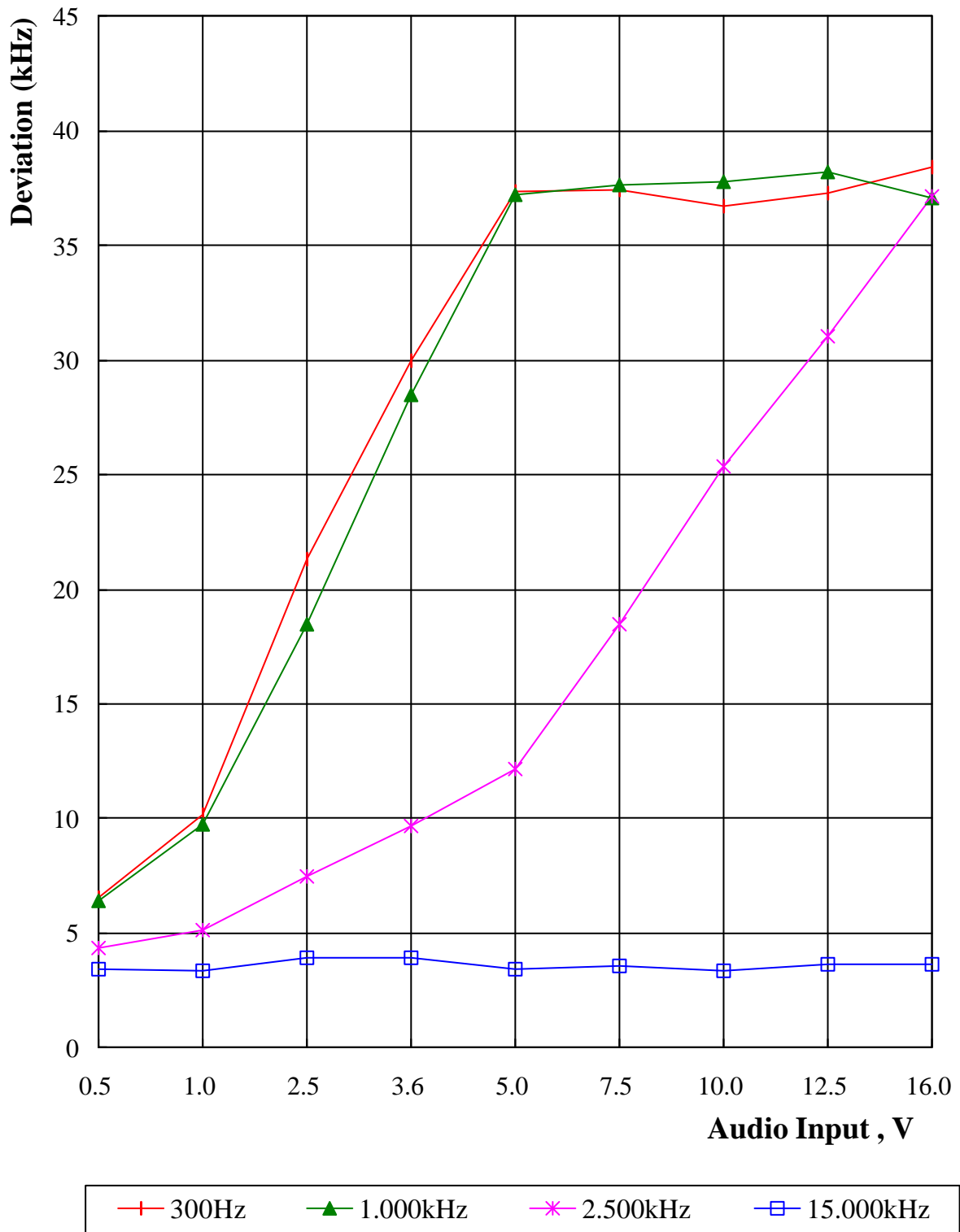

Chart 4.2 Modulation Limiting Measurement Positive



Chapter 5 Occupied Bandwidth Measurement

5.1 Rules and Specification Limits

2.1049(c)(1): ANSI/ TIA / EIA-603-1992, Paragraph 2.2.11.

74.861(e)(3): Any form of modulation may be used. A maximum deviation of $\pm 75\text{kHz}$ is permitted when frequency modulation is employed.

74.861(e)(5): The operation bandwidth shall not exceed 200kHz.

5.2 Test Configuration & List of Test Instruments

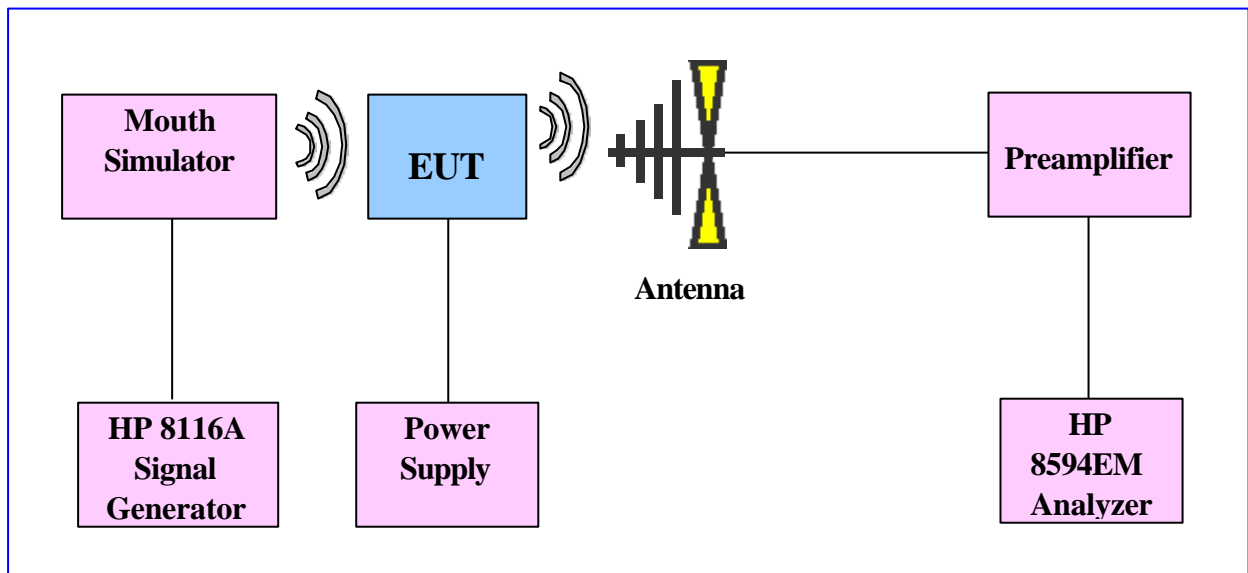

5.3 List of test Instrument

<u>Instrument Name</u>	<u>Model No.</u>	<u>Brand</u>	<u>Input Impedance</u>
Spectrum analyzer (9K~1.8GHz)	8594EM	HP	50
Preamplifier (30MHz~1GHz)	TRC001	TRC	50
Signal Generator 50 MHz	HP8116A	HP	50
Bi-log Antenna	CBL6141A	SCHAFFNER	50

5.4 Measurement Procedure

1. Connect the EUT as Section 4.2 .
2. Plot the unmodulated chart shows on spectrum.
3. Set the output of the signal generator to 300Hz, 1kHz, 2.5kHz and 15kHz. Increase the amplitude of the signal, while monitoring the modulation meter. Until modulation is max. Measure the bandwidth under 26 dB compared to the unmodulated fundamental carrier peak level of the modulated signal displayed on the spectrum analyzer.
4. The occupied Bandwidth was measured as follow pages.

5.5 Measurement Result

The occupied bandwidth's plot is presented on following pager, which illustrates compliance with the rules.

Calculation of Necessary Bandwidth (Bn)

$$B_n = 2M + 2D$$

$$M = \text{Max. Modulation Frequency} = 15.0 \text{ kHz}$$

$$D = \text{Peak Frequency Deviation} = 38.44 \text{ kHz (Chart 4-2)}$$

$$K = 1$$

$$B_n = 106.880 \text{ kHz}$$

Unmodulation

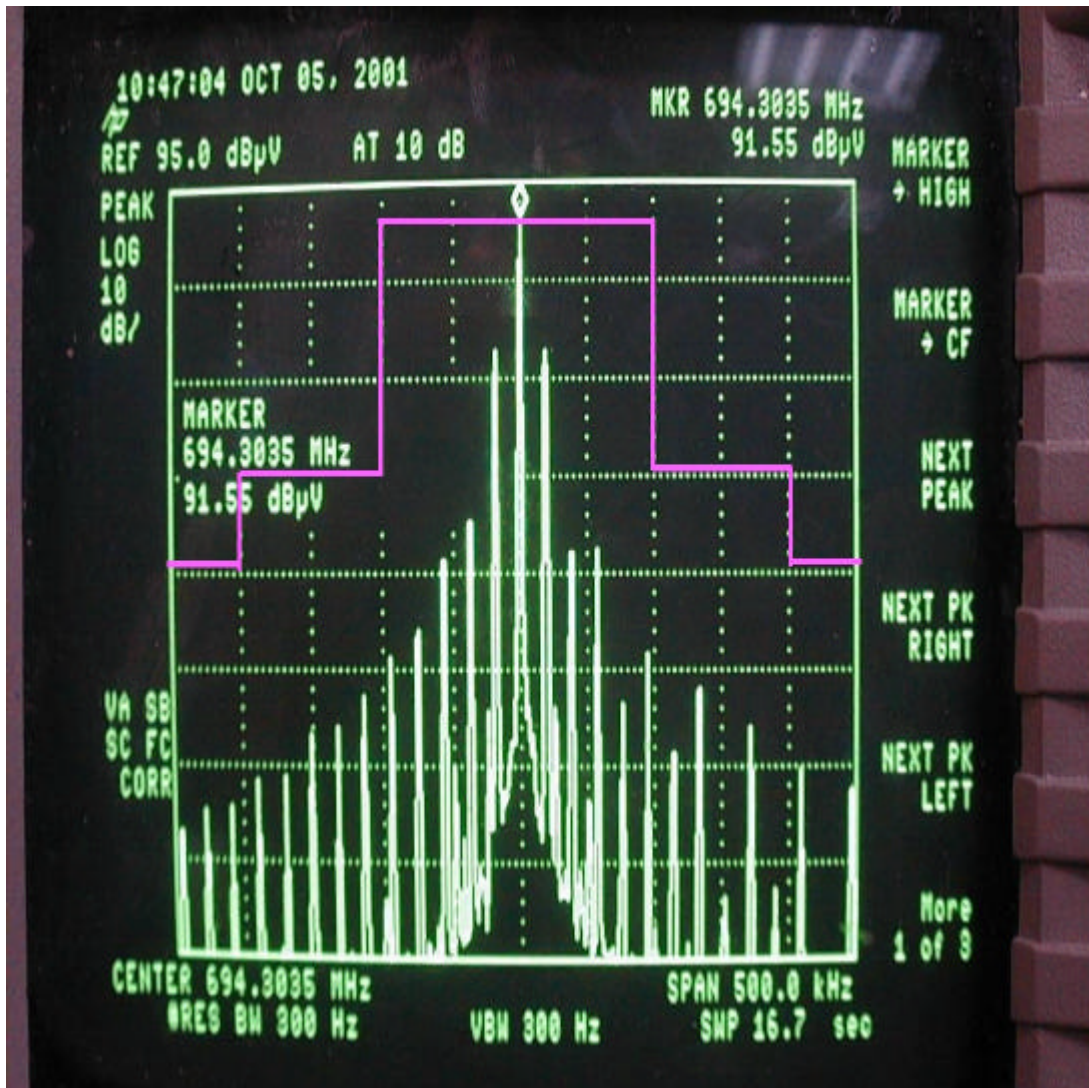

300Hz

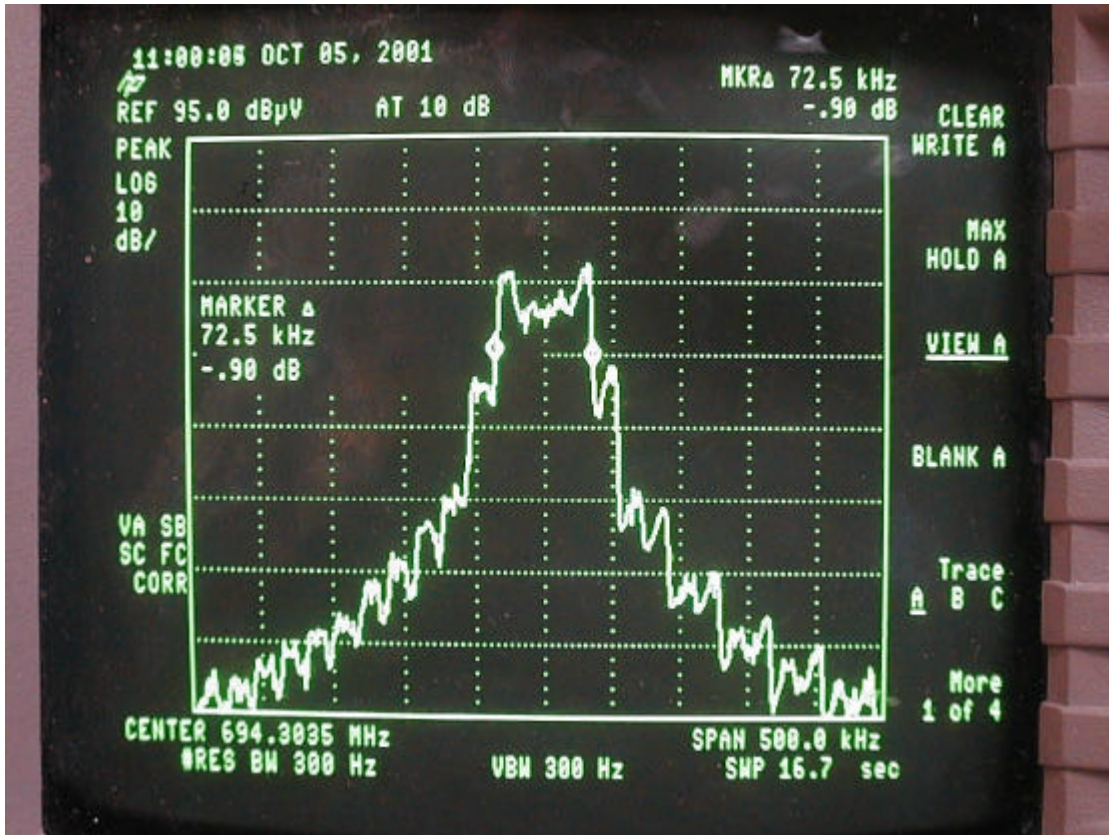

1kHz

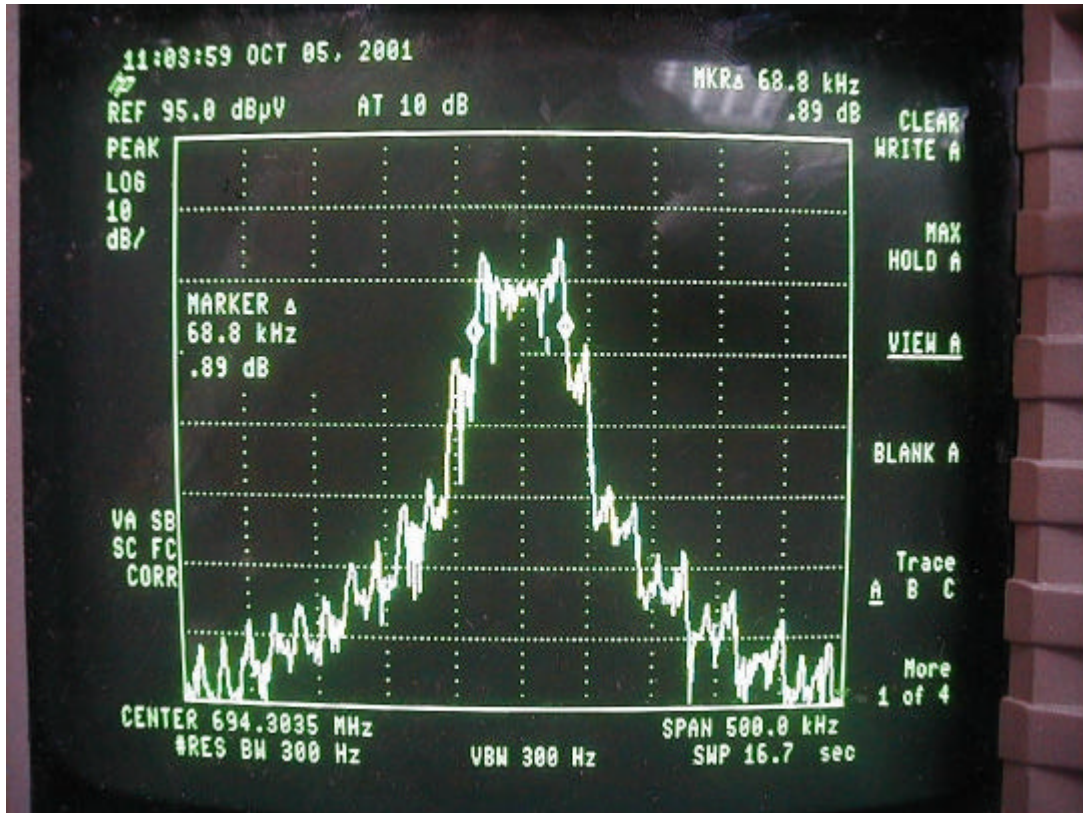

2.5kHz

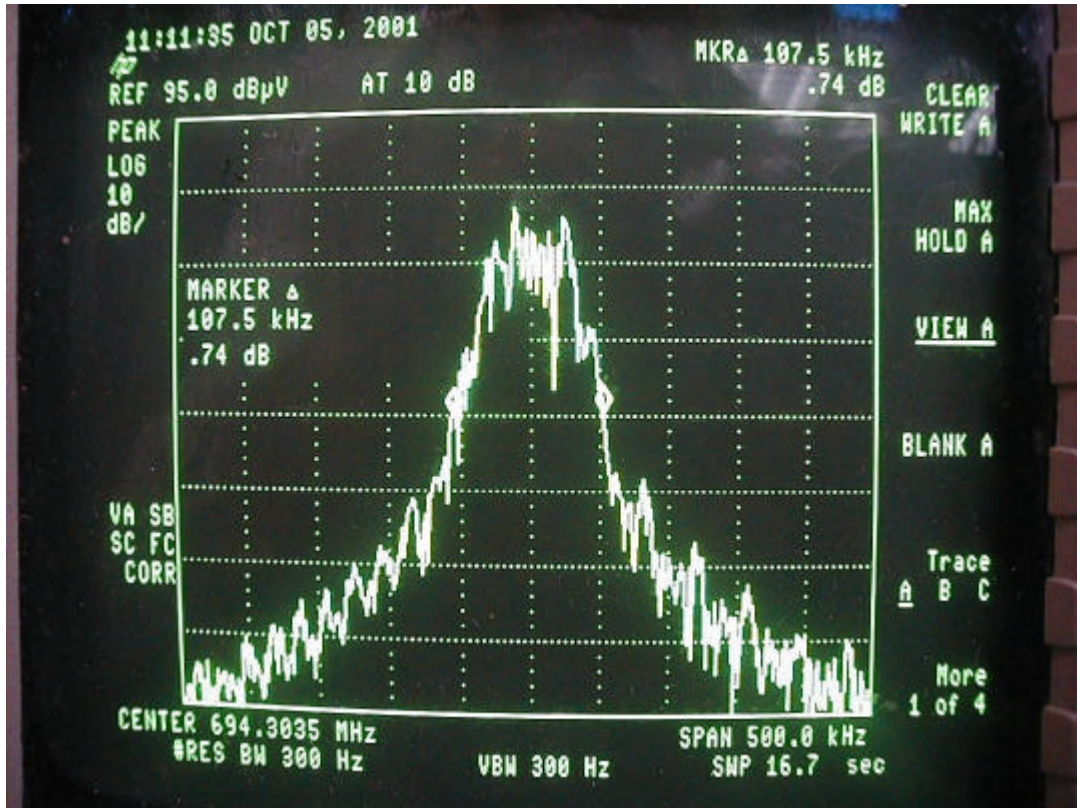

15kHz

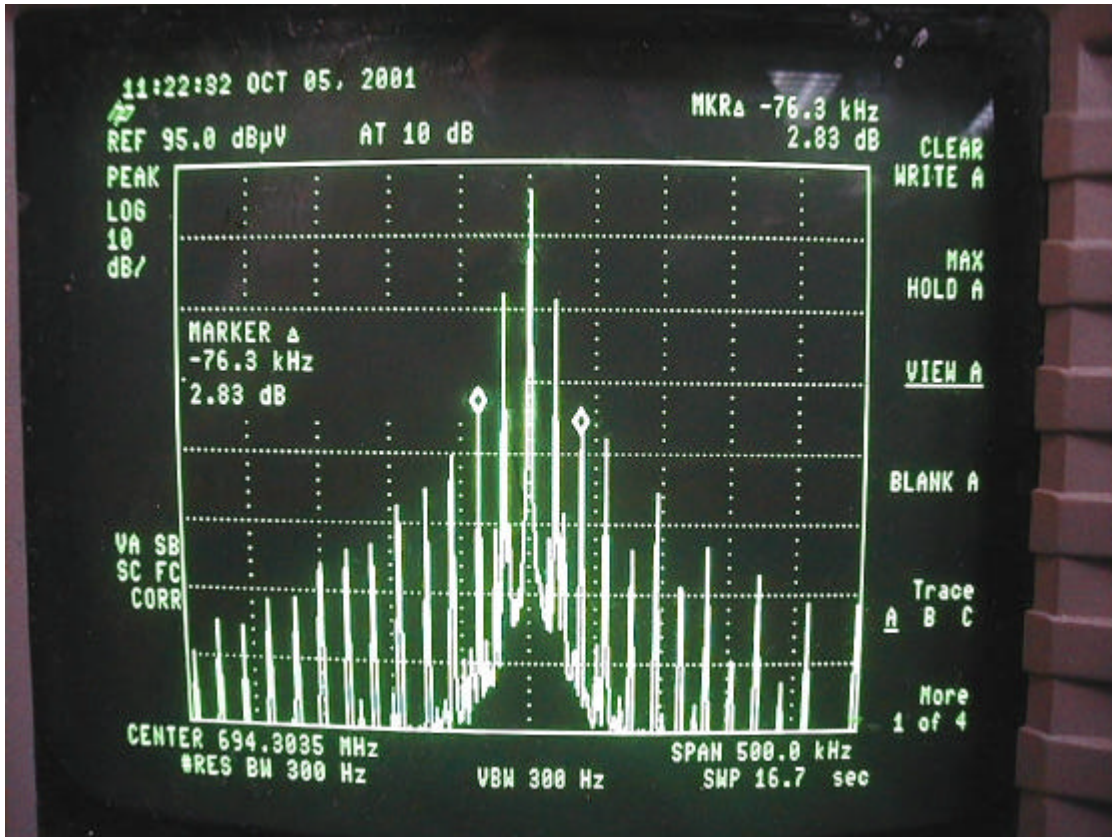

Chapter 6 Field Strength of Spurious Radiation Measurement

6.1 Rules and Specification Limits

2.1053(a): ANSI/ TIA/ EIA-603-1992, Paragraph 2.2.12

Measurements shall be made to detect spurious emissions that may be radiated directly from the cabinet, control circuits, Power leads, or intermediate circuit elements under normal conditions of installation and operation.

74.861(e)(6)(iii):

Spurious and harmonics must be at least $43 + 10 \log (\text{Output Power})$ below the Carrier peak

2.1057:

In all measurements set forth, the spectrum should be investigated from the lowest radio frequency generated in the equipment up to at least the 10th harmonic of the carrier frequency.

6.2 Measurement Condition & Setup

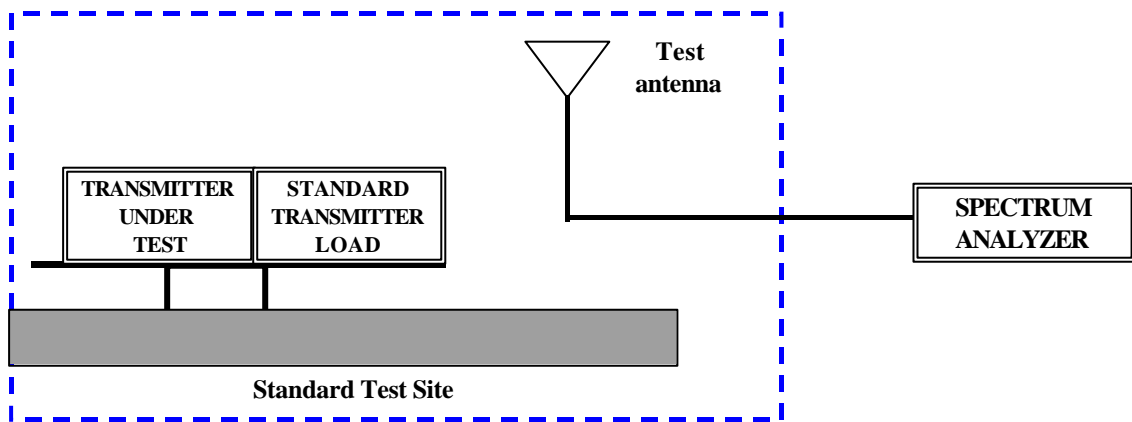

1. Connect the equipment as illustrated.
2. Adjust the spectrum analyzer for the following setting:
 - a) Resolution Bandwidth 3kHz

- b) Video Bandwidth 10kHz
- c) Sweep Speed 2000Hz /second
- d) Detector mode = Positive Peak

3. Place the transmitter to be tested on the turntable in the standard test site. The transmitter is transmitting into a non-radiating load, which is placed on the turntable. The RF cable to this load should be of minimum length.
4. For each spurious measurement the test antenna should be adjusted to the correct length for the frequency involved. The length may be determined from a calibration ruler supplied with the equipment. Measurements shall be made from the lowest radio frequency generated in the equipment to the tenth harmonic of the carrier, except for the region close to the carrier equal to \pm the test bandwidth (see section 1.3.4.4)
5. For each spurious frequency, raise and lower the test antenna from 1m to 4m to obtain a maximum reading on the spectrum analyzer with the test antenna at horizontal polarity. Then the turntable should be rotated 360° to determine the maximum reading. Repeat this procedure to obtain the highest possible reading. Record this maximum reading.
6. Repeat step (5) for each spurious frequency with the test antenna polarized vertically.

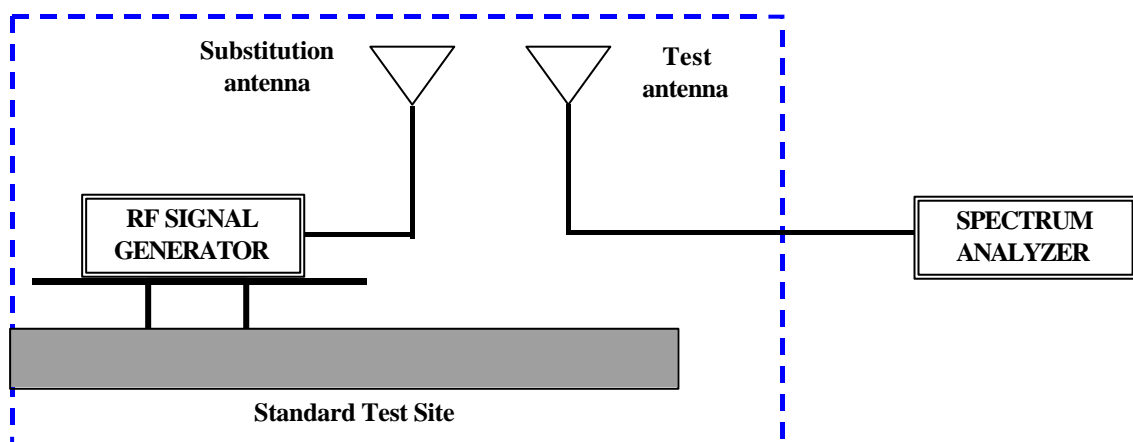

7. Reconnect the equipment as illustrated.
8. Keep the spectrum analyzer adjusted as in step (2)

9. Remove the transmitter and replace it with a substitution antenna (the antenna should be half-wavelength for each frequency involved). The center of the substitution antenna should be approximately at the same location as the center of the transmitter. At the lower frequencies, where the substitution antenna is very long, this will be impossible to achieve when the antenna is polarized vertically. In such case the lower end of the antenna should be 0.3m above the ground.
10. Feed the substitution antenna at the transmitter end with a signal generator connected to the antenna by means of a non-radiating cable. With the antennas at both ends horizontally polarized and with the signal generator tuned to a particular spurious frequency, raise and lower the test antenna to obtain a maximum reading at the spectrum analyzer. Adjust the level of the signal generator output until the previously recorded maximum reading for this set of conditions is obtained. This should be done carefully repeating the adjustment of the test antenna and generator output.
11. Repeat step (10) with both antennas vertically polarized for each spurious frequency.
12. Calculate power in dBm into a reference ideal half-wave dipole antenna by reducing the readings obtained in steps (10) and (11) by the power loss in the cable between the generator and the antenna and further corrected for the gain of the substitution antenna used relative to an ideal half-wave dipole antenna.
13. The levels record in step (12) are the absolute levels of radiated spurious emissions in dBm. The radiated spurious emissions in dB can be calculated by the following:

Radiated spurious emissions (dB) =

$$10 \log_{10} \left[\frac{\text{TX power in watts}}{0.001} \right] - \text{the levels in step (12)}$$

6.3 List of Measurement Instruments

<u>Instrument Name</u>	<u>Model No.</u>	<u>Brand</u>	<u>Serial No.</u>	<u>Calibration Date</u>	
				<u>Last time</u>	<u>Next time</u>
EMI Receiver	8546A	H P	3520A00242	06/29/01	06/29/02
RF Filter Section	85460A	H P	3448A00217	06/29/01	06/29/02
Bi-log Antenna	CBL6141A	Schaffner	4206	03/09/01	03/09/02
Switch/Control Unit (> 30MHz)	3488A	HP	N/A	11/20/00	11/20/01
Auto Switch Box (> 30MHz)	ASB-01	TRC	9904-01	11/20/00	11/20/01
Spectrum Analyzer	8564E	HP	US36433002	08/01/01	08/01/02
Microwave Preamplifier	83051A	HP	3232A00347	08/01/01	08/01/02
Horn Antenna	3115	EMCO	9704 – 5178	08/01/01	08/01/02
Anechoic Chamber (cable calibrated together)				05/20/01	05/20/02

The level of confidence of 95%, the uncertainty of measurement of radiated emission is ± 4.96 dB.

6.4 Measurement Result:

Test mode: Ch1---694.300MHz, Horizontal, 30 MHz ~ 18 GHz

Test Conditions:

Testing room : Temperature : 26 °C Humidity : 73 % RH

Testing site : Temperature : 31 °C Humidity : 75 % RH

<i>Frequency</i>	<i>Reading Amplitude</i>	<i>Ant. Height</i>	<i>Table</i>	<i>Correction Factors</i>	<i>Corrected Power</i>	<i>Attenuated below the mean power</i>	<i>Minimum Attenuation limit</i>
GHz	dBm	m	degree	dB	dBm	dBc	dBc
4.165	-75.43	1.00	206	-34.63	-40.80	52.72	24.91
4.858	-61.10	1.00	256	-35.58	-25.52	37.44	
5.563	-60.10	1.00	18	-36.91	-23.19	35.11	
6.245	-65.10	1.00	165	-37.64	-27.46	39.38	
6.949	-74.93	1.00	55	-37.65	-37.28	49.20	
7.643	-73.26	1.00	248	-41.28	-31.98	43.90	

Note:

1. Corrected Amplitude = Reading Amplitude – Correction Factors
2. The maximum field measured is 11.92 dBm
 Attenuated below the mean power = Power – Corrected Power
 {For example: 11.92 – (- 40.80) = 52.72 dBc}
3. Attenuation required = 43 + 10 log (15.558 mW) = 24.91
- 4. Measurement result passed by more than 20dB margin.**

Test mode: Ch1---694.300MHz , Vertical , 30 MHz ~ 18 GHz

<i>Frequency</i>	<i>Reading Amplitude</i>	<i>Ant. Height</i>	<i>Table</i>	<i>Correction Factors</i>	<i>Corrected Power</i>	<i>Attenuated below the mean power</i>	<i>Minimum Attenuation limit</i>
GHz	dBm	m	degree	dB	dBm	dBc	dBc
1.388	-56.54	1.00	339	-3.72	-52.82	64.74	24.91
2.768	-59.93	1.00	125	2.68	-62.61	74.53	
4.165	-63.26	1.00	5	-35.03	-28.23	40.15	
4.858	-55.43	1.00	258	-34.80	-20.63	32.55	
6.245	-61.93	1.00	54	-37.46	-24.47	36.39	
5.552	-58.60	1.00	108	-36.26	-22.34	34.26	

Note: Measurement result passed by more than 20dB margin.

Test mode: Ch9---699.600MHz , Horizontal , 30 MHz ~ 18 GHz

<i>Frequency</i>	<i>Reading Amplitude</i>	<i>Ant. Height</i>	<i>Table</i>	<i>Correction Factors</i>	<i>Corrected Power</i>	<i>Attenuated below the mean power</i>	<i>Minimum Attenuation limit</i>
GHz	dBm	m	degree	dB	dBm	dBc	dBc
1.395	-56.49	1.00	56	-4.61	-51.88	61.62	22.73
4.880	-62.10	1.00	112	-35.61	-26.49	36.23	
5.573	-57.93	1.00	50	-36.89	-21.04	30.78	
6.278	-61.10	1.00	56	-37.81	-23.29	33.03	
6.982	-73.26	1.00	224	-37.55	-35.71	45.45	
7.675	-73.26	1.00	31	-41.20	-32.06	41.80	

Note:

1. Corrected Amplitude = Reading Amplitude – Correction Factors
2. The maximum field measured is 9.74 dBm
 Attenuated below the mean power = Power – Corrected Power
 (For example: 9.74 – (-51.88) = 61.62 dBc
3. Attenuation required = 43 + 10 log (9.410 mW) = 22.73
4. **Measurement result passed by more than 20dB margin.**

Test mode: Ch9---699.600MHz , Vertical , 30 MHz ~ 18 GHz

<i>Frequency</i>	<i>Reading Amplitude</i>	<i>Ant. Height</i>	<i>Table</i>	<i>Correction Factors</i>	<i>Corrected Power</i>	<i>Attenuated below the mean power</i>	<i>Minimum Attenuation limit</i>
GHz	dBm	m	degree	dB	dBm	dBc	dBc
2.085	-66.10	1.00	319	-0.18	-65.92	75.66	22.73
2.778	-61.76	1.00	213	2.72	-64.48	74.22	
4.880	-57.43	1.00	55	-34.84	-22.59	32.33	
5.573	-54.76	1.00	28	-36.23	-18.53	28.27	
6.278	-59.43	1.00	154	-37.70	-21.73	31.47	
6.982	-67.93	1.00	8	-37.72	-30.21	39.95	

Note: Measurement result passed by more than 20dB margin.

Test mode: Ch16---704.300MHz , Horizontal , 30 MHz ~ 18 GHz

Frequency	Reading Amplitude	Ant. Height	Table	Correction Factors	Corrected Power	Attenuated below the mean power	Minimum Attenuation limit
GHz	dBm	m	degree	dB	dBm	dBc	dBc
1.401	-65.80	1.00	54	-4.61	-61.19	71.26	23.07
4.902	-61.76	1.00	296	-35.61	-26.15	36.22	
5.606	-55.76	1.00	47	-36.89	-18.87	28.94	
6.299	-60.60	1.00	58	-37.81	-22.79	32.86	
7.003	-72.43	1.00	226	-37.55	-34.88	44.95	
7.708	-73.93	1.00	157	-41.20	-32.73	42.80	

Note:

1. Corrected Amplitude = Reading Amplitude – Correction Factors
2. The maximum field measured is 10.07 dBm
 Attenuated below the mean power = Power – Corrected Power
 (For example: 10.07 – (- 59.06) = 43.12 dBc
3. Attenuation required = 43 + 10 log (10.162 mW) = 23.07
4. **Measurement result passed by more than 20dB margin.**

Test mode: Ch16---704.300MHz , Vertical , 30 MHz ~ 18 GHz

<i>Frequency</i>	<i>Reading Amplitude</i>	<i>Ant. Height</i>	<i>Table</i>	<i>Correction Factors</i>	<i>Corrected Power</i>	<i>Attenuated below the mean power</i>	<i>Minimum Attenuation limit</i>
GHz	dBm	m	degree	dB	dBm	dBc	dBc
2.085	-56.82	1.00	8	-0.18	-56.64	66.71	23.07
2.778	-62.60	1.00	147	2.72	-65.32	75.39	
4.880	-52.43	1.00	164	-34.84	-17.59	27.66	
5.573	-57.93	1.00	22	-36.23	-21.70	31.77	
6.278	-59.26	1.00	238	-37.70	-21.56	31.63	
6.982	-69.60	1.00	307	-37.72	-31.88	41.95	

Note: Measurement result passed by more than 20dB margin.

Chapter 7 Frequency Stability Tolerance Measurement

7.1 Rules and Specification Limits

2.1055, ANSI/ TIA/ EIA-603-1992, Paragraph 2.2.2 .

74.861(e)(4): The frequency tolerance of the transmitter shall be 0.005 percent.

7.2 Measurement Condition & Setup with Temperature Variation

1. Place the EUT in the chamber, powered in its normal operation.
2. Set the temperature of the chamber -30 degree Centigrade. Allow the equipment to stabilize at that temperature.
3. Measured the carrier frequency using preamplifier and frequency counter.
4. Repeated procedures 1 to 3 from -20 to 50 degree Centigrade at intervals of 10 degree.

7.3 List of Measurement Instruments with Temperature Variation List of test Instrument

<u>Instrument Name</u>	<u>Model No.</u>	<u>Brand</u>	<u>Remark</u>
Spectrum Analyzer	8591A	H P	1.8GHz
Temperature Chamber	THS-MV2	King Son	
Near field Probe	7405-901	EMCO	
Power Supply	GPR-6030	Good Will	
Auto Transformer	Powerstat	Supprior Elec. Co.	

7.4 Measurement Configuration of Temperature Variation Test:

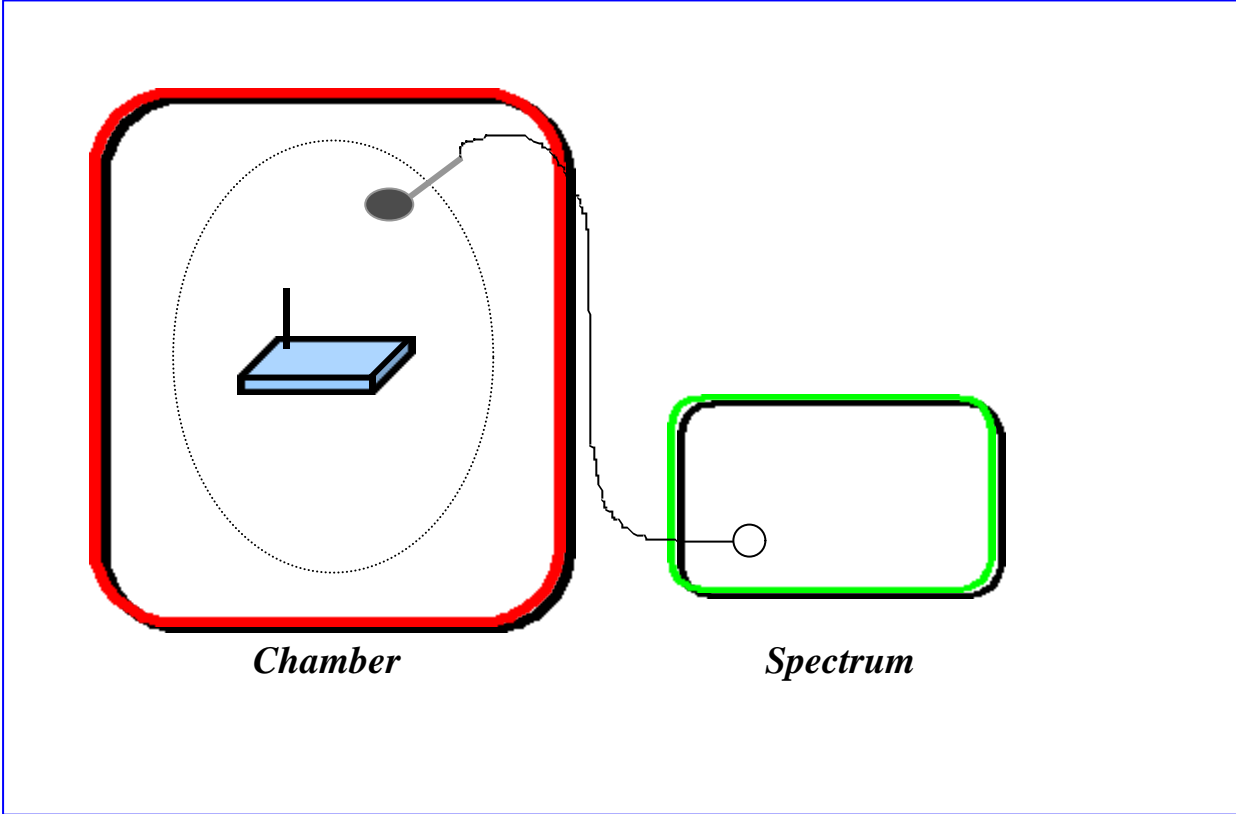

7.5 Measurement Result with Temperature Variation

A plot and table is presented which illustrates compliance with the rule where the center frequency is 694.300 MHz (channel 1).

Temperature Variation Table

<i>Temperature (Centigrade)</i>	<i>Frequency (MHz)</i>	<i>Tolerance (MHz)</i>
-30	694.3073	694.265285 to 694.334715
-25	694.3081	
-20	694.3093	
-15	694.3092	
-10	694.3101	
-5	694.3099	
0	694.3093	
5	694.3087	
10	694.3078	
15	694.3067	
20	694.3058	
25	694.3047	
30	694.3048	
35	694.3051	
40	694.3043	
45	694.3036	
50	694.3028	

Temperatuer Variation Vs. Frequency Chart

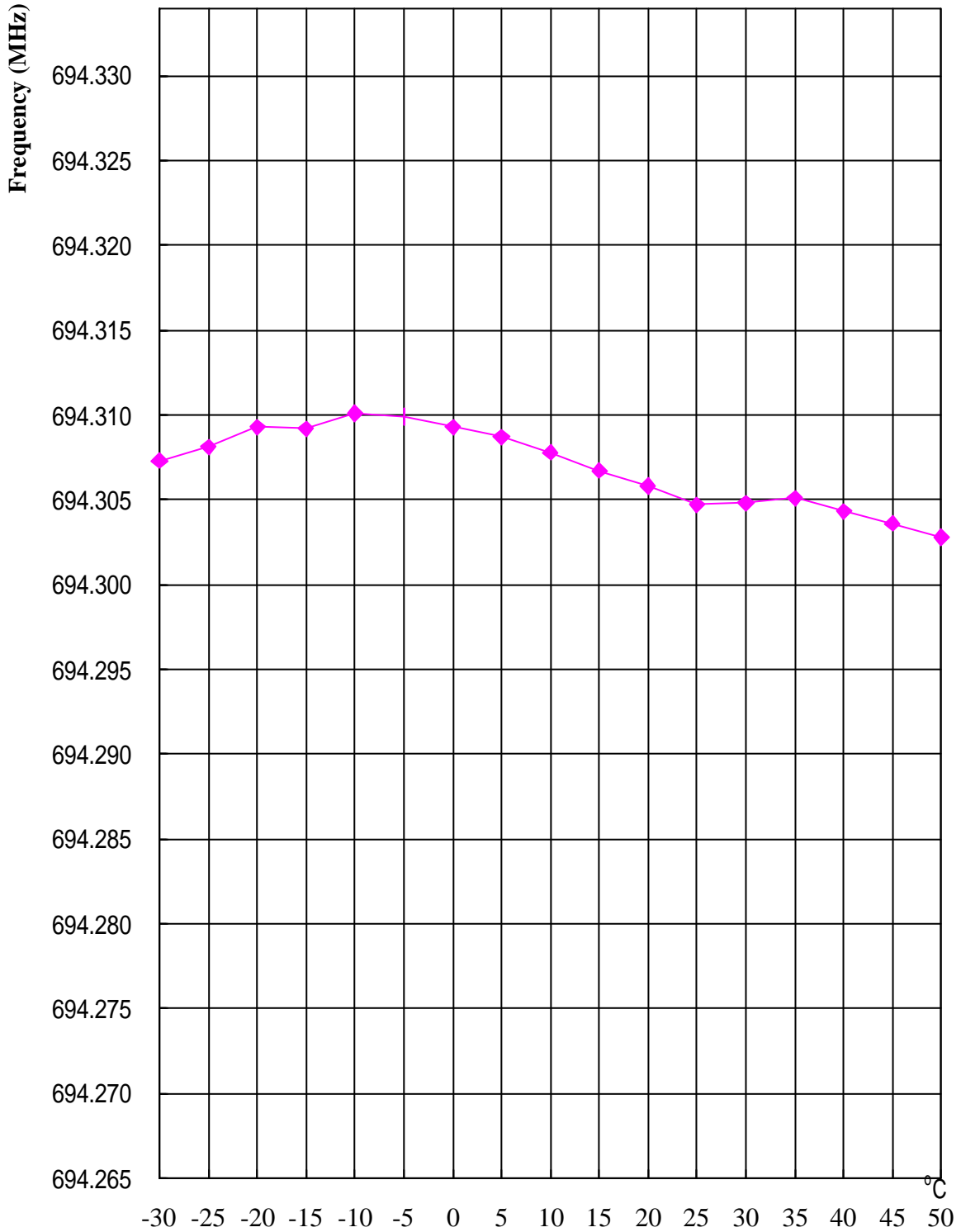

7.6 Measurement Condition & Setup with Voltage Variation

1. Attached the power line of the power supply to the battery position of the EUT.
2. Tuned the output power level to battery end point, 85 %, 100%, 115% of the normal operation power of EUT.
3. Recorded the frequency with a frequency counter.

7.7 Configuration of Voltage Variation Test

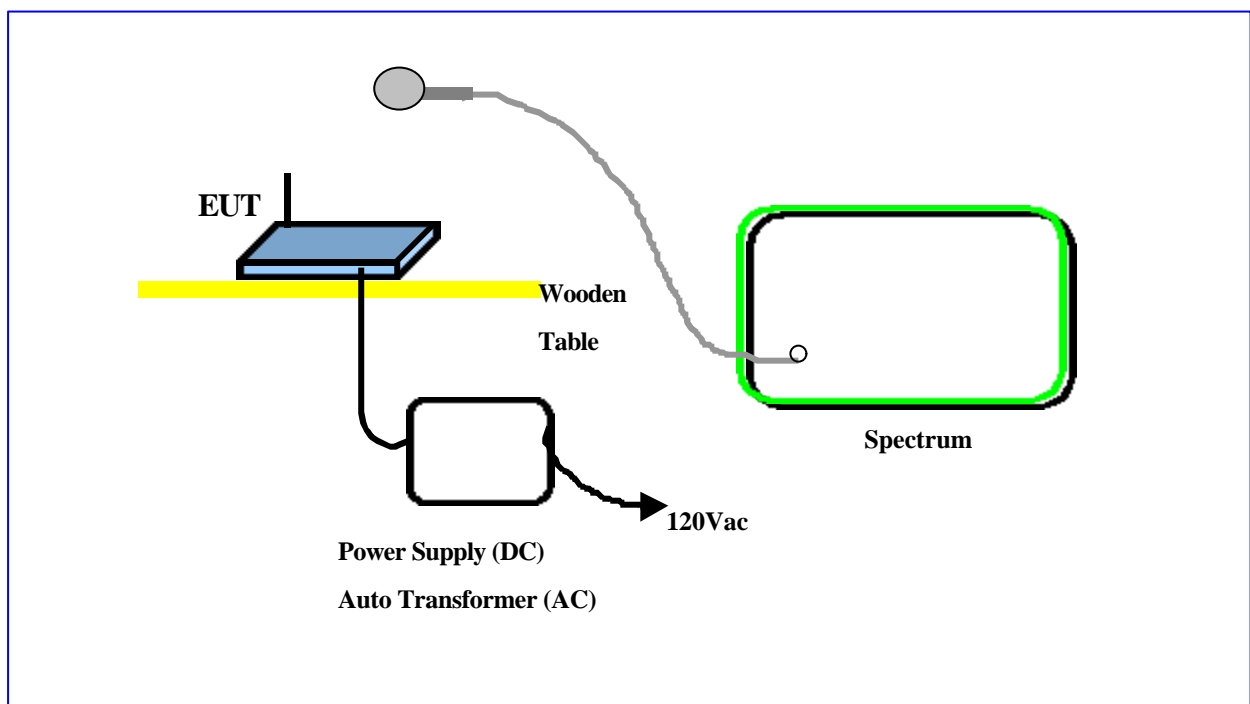

7.8 Measurement Result with Voltage Variation

Frequency Stability of Voltage Variation Measurement Table

<i>Supply Voltage (Volt)</i>	<i>Frequency (MHz)</i>	<i>Tolerance (MHz)</i>
102 (85%)	694.30480	694.265285 ~ 694.334715
120 (100%)	694.30513	
138 (115%)	694.30460	
Endpoint-Voltage: 52V		