

PD2-TX-5000-S Report of Measurements

List of measurements performed:

- RF Power Output
- Modulation Characteristics-Deviation Frequency Response
- Modulation Characteristics-Modulation Sensitivity
- Occupied Bandwidth/Spurious Emissions/Emissions Masks
- Frequency Stability-Temperature Stability
- Frequency Stability-Power Supply Stability

PD2-TX-5000-S RF Power Output

Relevant FCC Chapter:

(a) 2.1046 Measurements required: RF power output.
For transmitters other than single side-band, independent side-band and controlled carrier radiotelephone, power output shall be measured at the RF output terminals when the transmitter is adjusted in accordance with the tune-up procedure to give the values of current and voltage on the circuit elements specified in 2.1033(c)(8). The electrical characteristics of the radio frequency load attached to the output terminals when this test is made shall be stated.

2.1033 Application for certification.

(c) Applications for equipment other than that operating under parts 15 and 18 of the rules shall be accompanied by a technical report containing the following information:

(8) The dc voltages applied to and dc currents into the several elements of the final radio frequency amplifying device for normal operation over the power range.

90.205 Power and antenna height limits.

Applicants for licenses must request and use no more power than the actual power necessary for satisfactory operation. Except where otherwise specifically provided for, the maximum power that will be authorized to applicants whose license applications for new stations are filed after August 18, 1995 is as follows:

(o) 2450-2483.5 MHz. The maximum transmitter power is 5 watts.

The maximum measured output power over supply voltage and frequency is 1.102 watts. Therefore requirement 90.205(o) is met.

Test Setup:

The setup for this test is shown below.

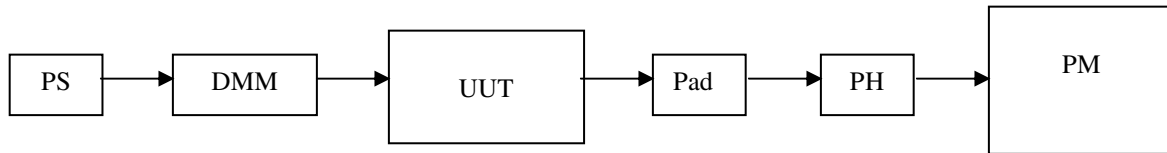

For specific test equipment details see supporting file:
DTC_PD2TX5000S_EquipList.PDF

- PS - Power Supply: Item 1
- DMM - Digital Multimeter: Item 3
- UUT - PD2-TX-5000-S, SN SB057279
- Pad - 20dB Pad: Item 4
- PH - Power Head: Item 7
- PM - Power Meter: Item 6

**Figure 1 - RF Power Output vs Voltage and Frequency
(Pursuant to FCC Requirement 2.1046) - Raw Data**

Supply Volts	Power Out Vs Voltage		Power Out Vs Voltage		Power Out Vs Voltage	
	F= 2451.25 MHz		F=2466.00 MHz		F=2482.5 MHz	
	Power Out Watts	I dc Amp	Power Out Watts	I dc Amp	Power Out Watts	I dc Amp
10.2	4.31	5.68	4.15	5.69	4.01	5.69
12.0	4.83	5.83	4.64	5.83	4.58	5.83
13.8	4.87	6.04	4.71	6.04	4.72	6.03

Figure 2 - RF Power Output vs Frequency
(Pursuant to FCC Requirement 2.1046)

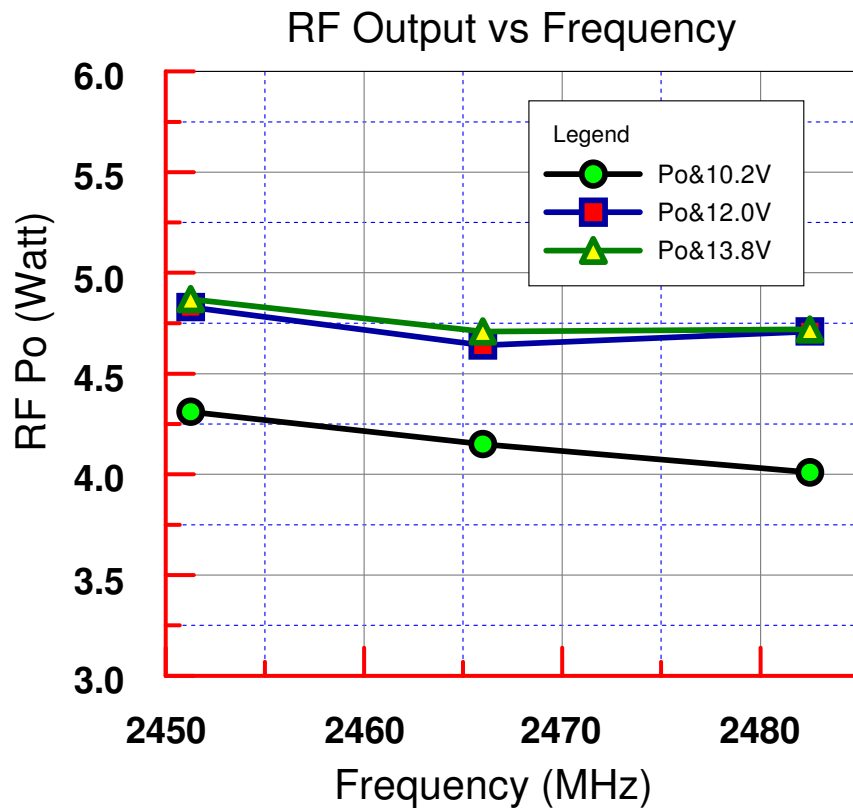
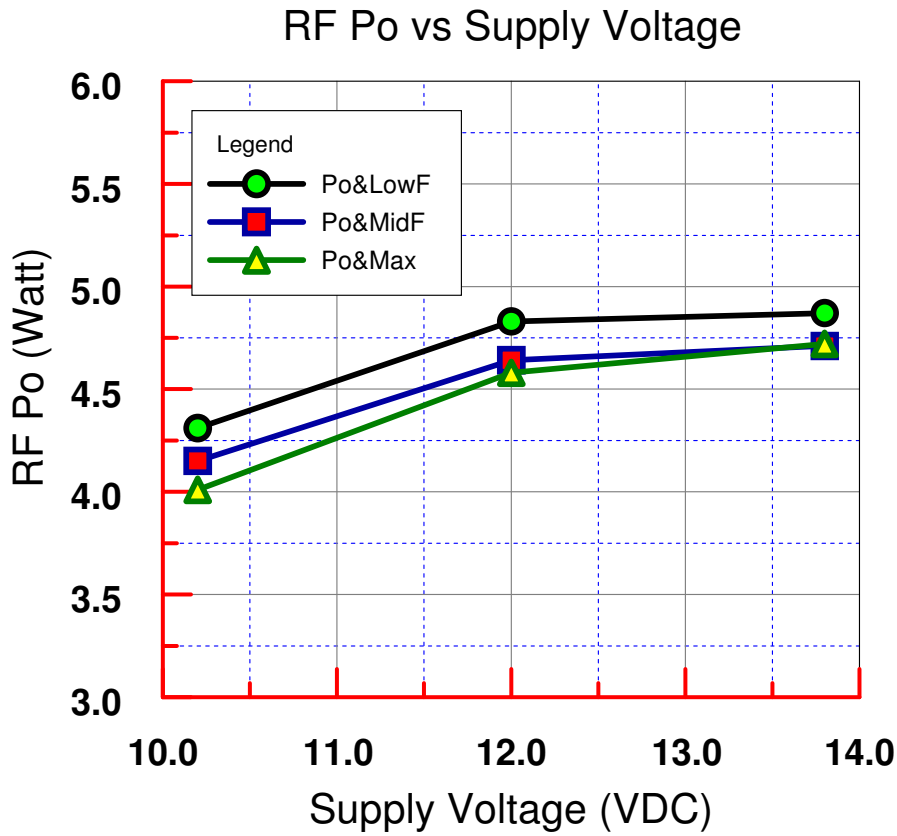

PD2-TX-5000-S Modulation Characteristics - Deviation Frequency Response

Relevant FCC Chapter:

2.1047 Measurements required: Modulation characteristics.

(d) *Other types of equipment.* A curve or equivalent data which shows that the equipment will meet the modulation requirements of the rules under which the equipment is to be licensed.

Test Method: See below

Test Results:

Whereas this is a pure Digital COFDM Video System with no audio sub-carriers, no test is relevant and none was performed.

PD2-TX-5000-S Modulation Characteristics

Modulation Sensitivity

Relevant FCC Chapter:

2.1047 Measurements required: Modulation characteristics.

(d) *Other types of equipment.* A curve or equivalent data which shows that the equipment will meet the modulation requirements of the rules under which the equipment is to be licensed.

Test Setup:

The setup for this test is shown below.

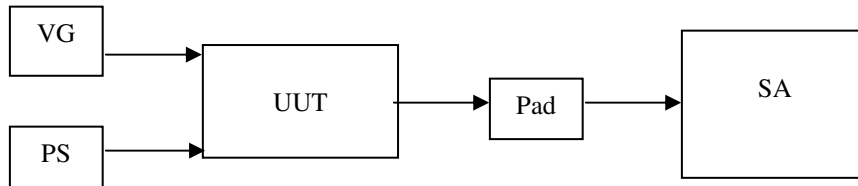

For specific test equipment details see supporting file:
DTC_PD2TX5000S_EquipList.PDF

- VG - Video Generator: Item 13
- PS - Power Supply: Item 1
- UUT - PD2-TX-5000-S, SN SB057279
- Pad - 20 dB Pad: Item 4
- SA - Spectrum Analyzer: Item 8, 9

Test Results:

Since the nature of a digital COFDM modulation system is such that the video input signal has no effect on the modulated carriers, no test is relevant and none was performed.

PD2-TX-5000-S Occupied Bandwidth / Spurious Emissions / Emission Masks**Relevant FCC Chapters:****2.1049 Measurements required: Occupied bandwidth.**

The occupied bandwidth, that is the frequency bandwidth such that, below its lower and above its upper frequency limits, the mean powers radiated are each equal to 0.5 percent of the total mean power radiated by a given emission shall be measured under the following conditions as applicable:

(h) Transmitters employing digital modulation techniques—when modulated by an input signal such that its amplitude and symbol rate represent the maximum rated conditions under which the equipment will be operated. The signal shall be applied through any filter networks, pseudo-random generators or other devices required in normal service. Additionally, the occupied bandwidth shall be shown for operation with any devices used for modifying the spectrum when such devices are optional at the discretion of the user.

2.1051 Measurements required: Spurious emissions at antenna terminals.

The radio frequency voltage or powers generated within the equipment and appearing on a spurious frequency shall be checked at the equipment output terminals when properly loaded with a suitable artificial antenna. Curves or equivalent data shall show the magnitude of each harmonic and other spurious emission that can be detected when the equipment is operated under the conditions specified in 2.1049 as appropriate. The magnitude of spurious emissions which are attenuated more than 20 dB below the permissible value need not be specified.

90.210 Emission masks.

(Under Part 90 section 210, the masks for equipment designated to operate in the 2.45 - 2.48GHz band are not specified in the Applicable Emission Masks Chart. Therefore, while the PD2-TX-5000-S has no provision to inject an audio sub carrier into the transmitted RF signal, we have applied Mask B as noted for "All other bands". Although Mask B generally pertains to equipment with an audio low pass filter, Mask C is completely inappropriate in that it does not allow for spread spectrum carriers within the designated bandwidth.

(b) *Emission Mask B* - For transmitters that are equipped with an audio low pass filter pursuant to 90.211(a), the power of any emission must be below the unmodulated carrier power (P) as follows:

- (1) On any frequency removed from the assigned frequency by more than 50 percent, but not more than 100 percent of the authorized bandwidth: At least 25 dB.
- (2) On any frequency removed from the assigned frequency by more than 100 percent, but not more than 250 percent of the authorized bandwidth: At least 35 dB.
- (3) On any frequency removed from the assigned frequency by more than 250 percent of the authorized bandwidth: At least $43 + 10 \log (P)$ dB.

Test Setup:

The setup for these tests is shown below.

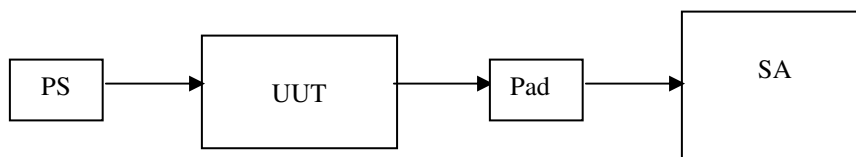

For specific test equipment details see supporting file:
DTC_PD2TX5000S_EquipList.PDF

- PS - Power Supply: Item 1
- UUT - PD2-TX-5000-S SN SB057279
- Pad - 20 dB Pad: Item 4
- SA- Spectrum Analyzer: Item 8, 9

PD2-TX-5000-S Spectrum Data - Occupied Bandwidth

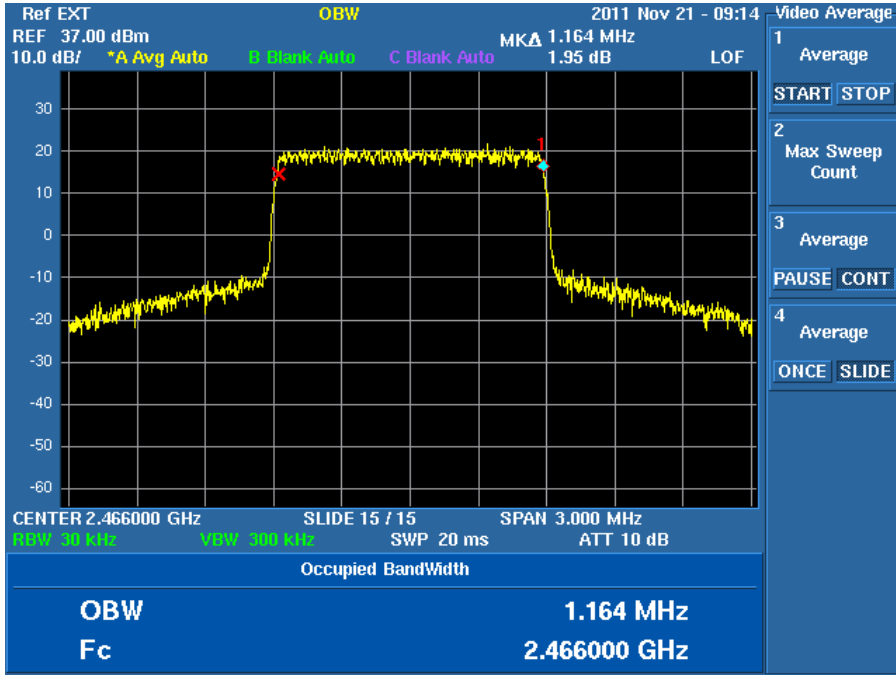

Fig. 1
Occupied Bandwidth Compliance
TX Mode = DOMO-N
Emission: 1M3W7D

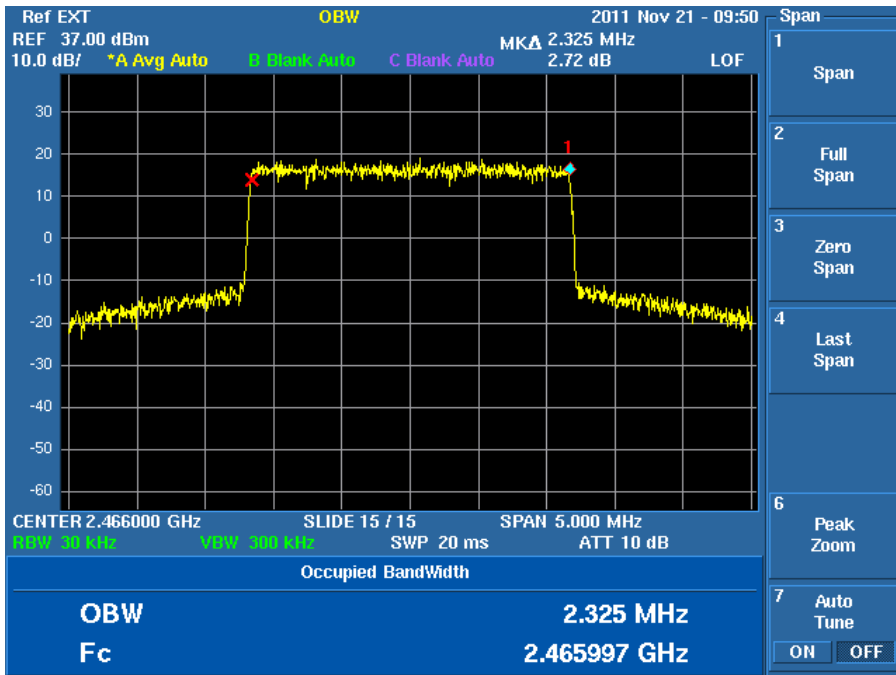

Fig. 2
Occupied Bandwidth Compliance
TX Mode = DOMO-W
Emission: 2M5W7D

PD2-TX-5000-S Spectrum Data - Occupied Bandwidth, Continued

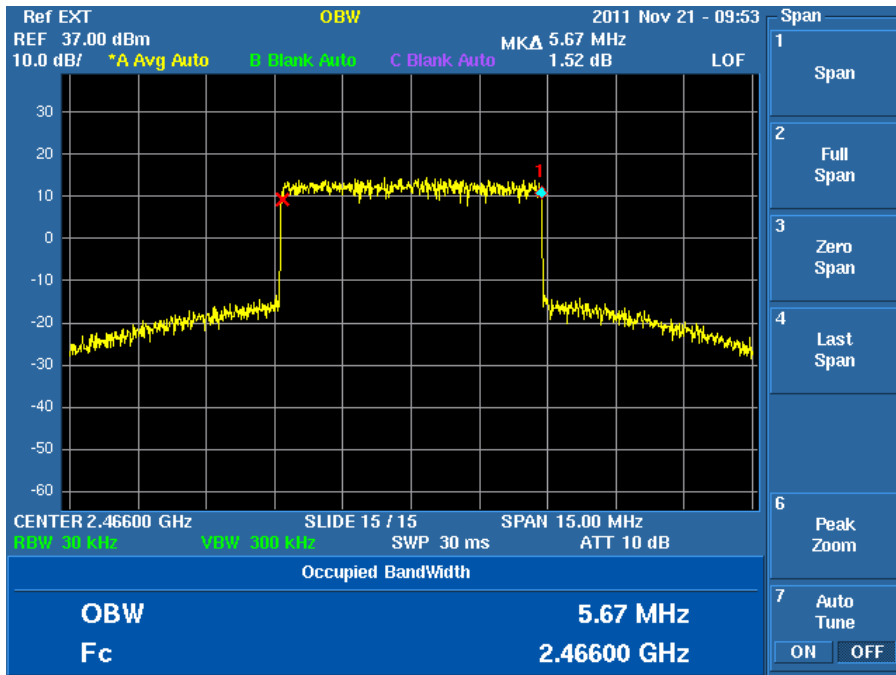

Fig. 3
Occupied Bandwidth Compliance
TX Mode = DVB-T 6 MHz
Emission: 6M0W7D

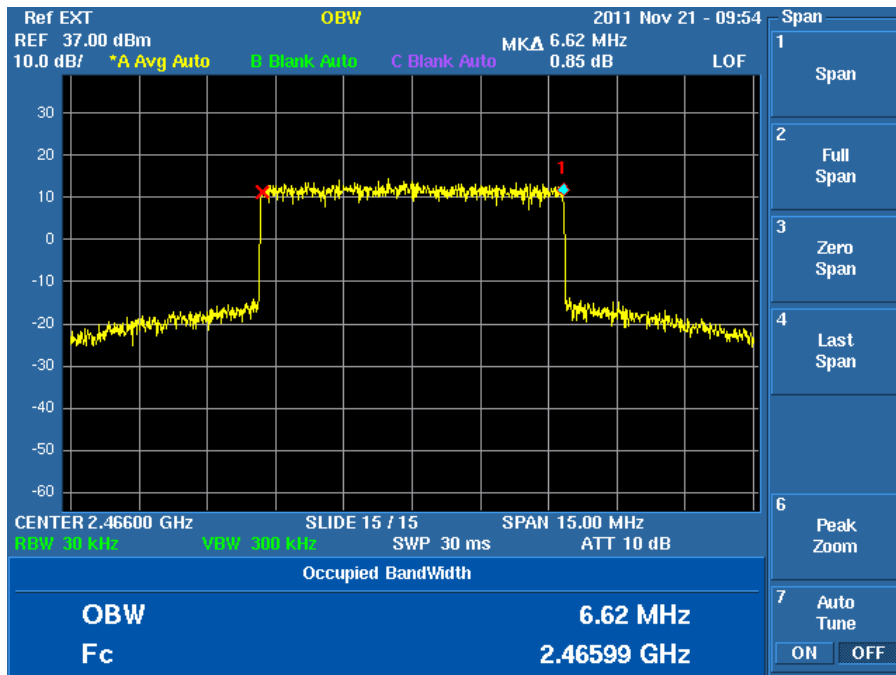

Fig. 4
Occupied Bandwidth Compliance
TX Mode = DVB-T 7 MHz
Emission: 7M0W7D

PD2-TX-5000-S Spectrum Data - Occupied Bandwidth, Continued

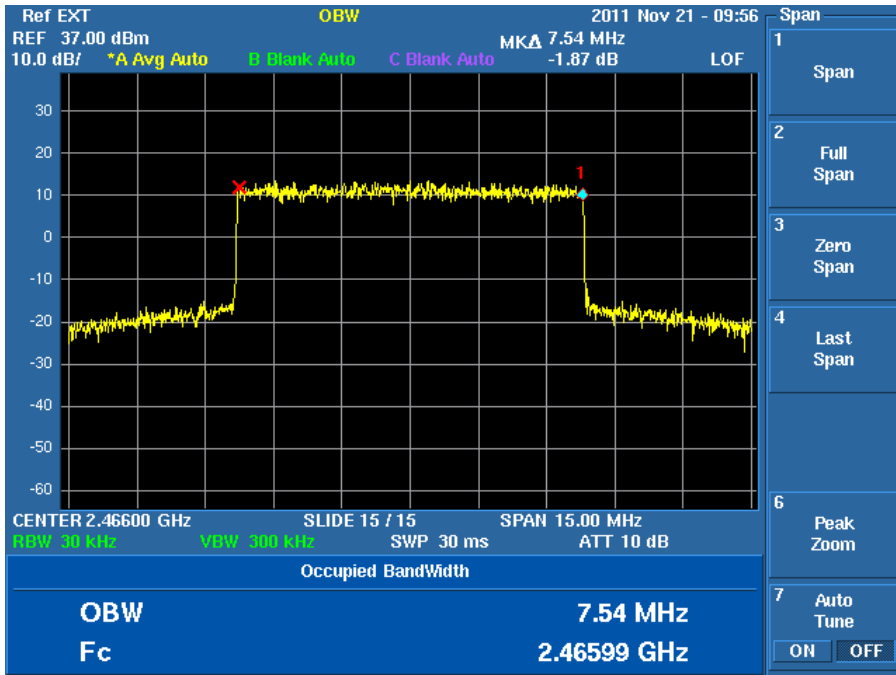

Fig. 5
Occupied Bandwidth Compliance
TX Mode = DVB-T 8 MHz
Emission: 8M0W7D

PD2-TX-5000-S Spurious Emissions at Antenna Terminals

Test Results:

Frequency Range Investigated: 30 MHz to 26 GHz

UUT: PD2-TX-5000-S

Measurement: Conducted Spurious

Frequency Range: 30 MHz to 26 GHz

FCC Limit (dBc) = $43 + 10 \cdot \text{LOG}(P) \text{ dBc} = 43 + 10 \cdot \text{LOG}(5) = -50 \text{ dBc}$

$P_{\text{carrier}} = 5000 \text{ mW} = +37 \text{ dBm}$

Fcc Limit (dBm) = $37 \text{ dBm} - 50 \text{ dBc} = \mathbf{-13 \text{ dBm}}$

$V_{\text{supply}} = 12.0 \text{ VDC}$

$I_{\text{supply}} = 1.4 \text{ ADC}$

Figures 6 through 10 show UUT compliance to the -13dBm limit of conducted spurious emissions in each of the five TX modes.

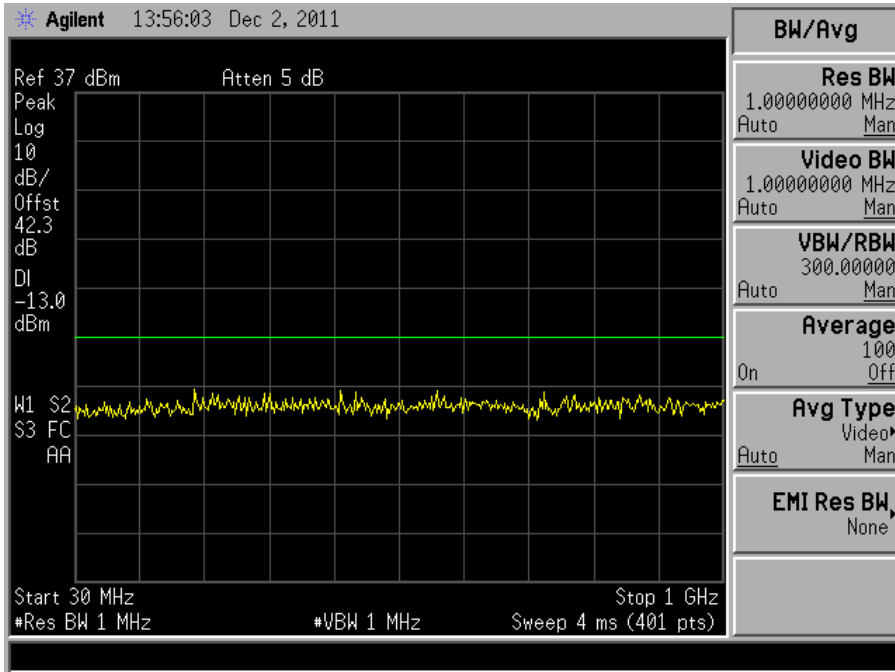

Fig. 6a
Spurious Emissions Compliance
30MHz – 1GHz
TX Mode = DOMO-N
Emission: 1M3W7D

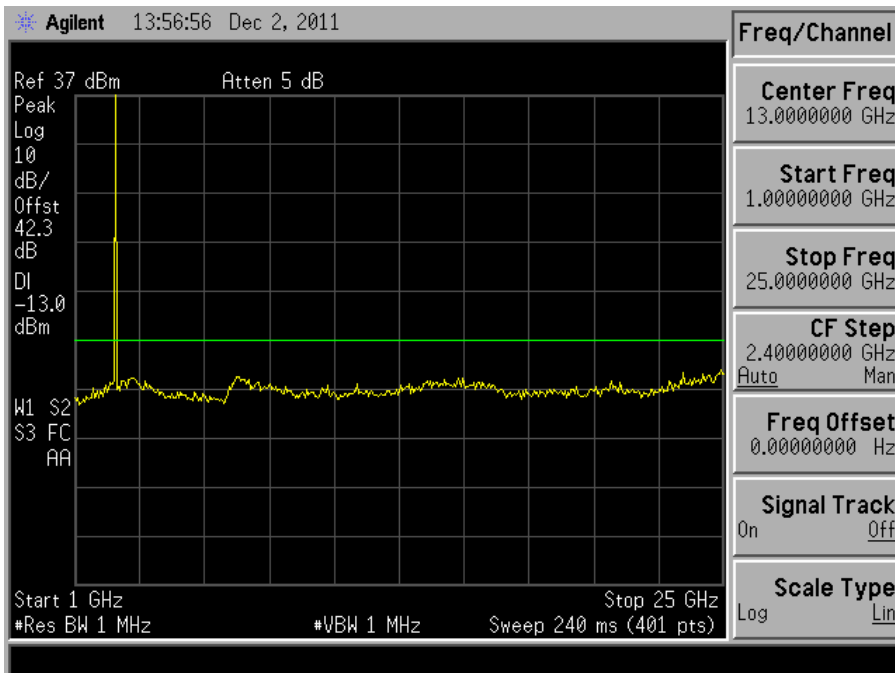

Fig. 6b
Spurious Emissions Compliance
1GHz – 25GHz
TX Mode = DOMO-N
Emission: 1M3W7D

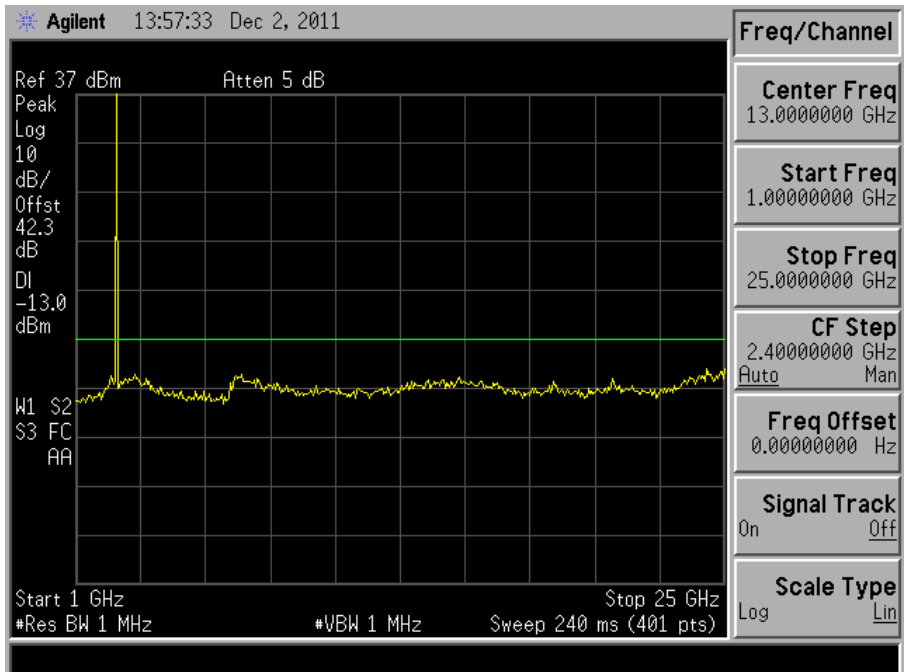

Fig. 7a
Spurious Emissions Compliance
30MHz – 1GHz
TX Mode = DOMO-W
Emission: 2M5W7D

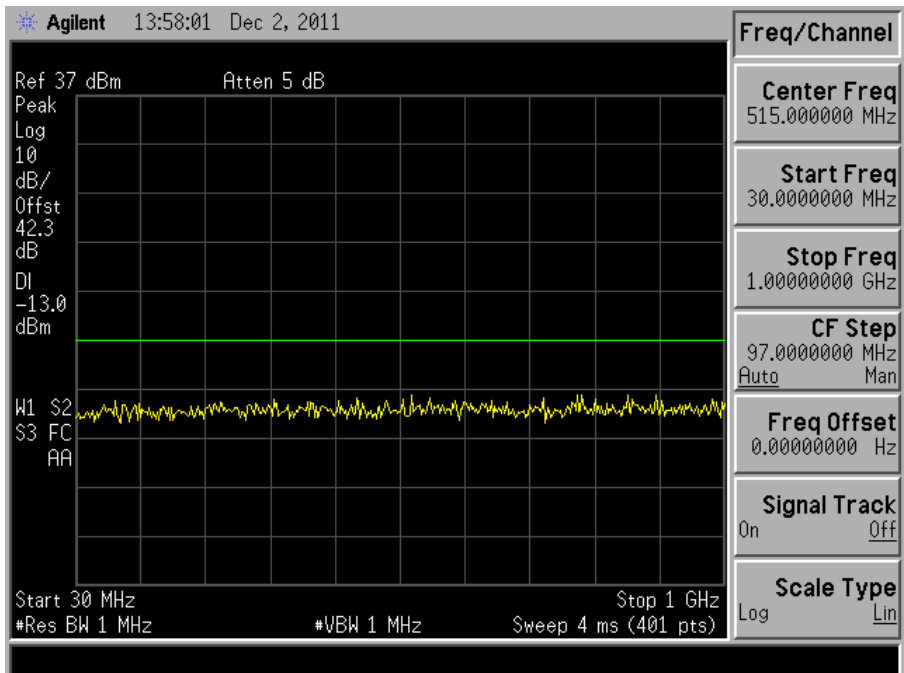

Fig. 7b
Spurious Emissions Compliance
1GHz – 25GHz
TX Mode = DOMO-W
Emission: 2M5W7D

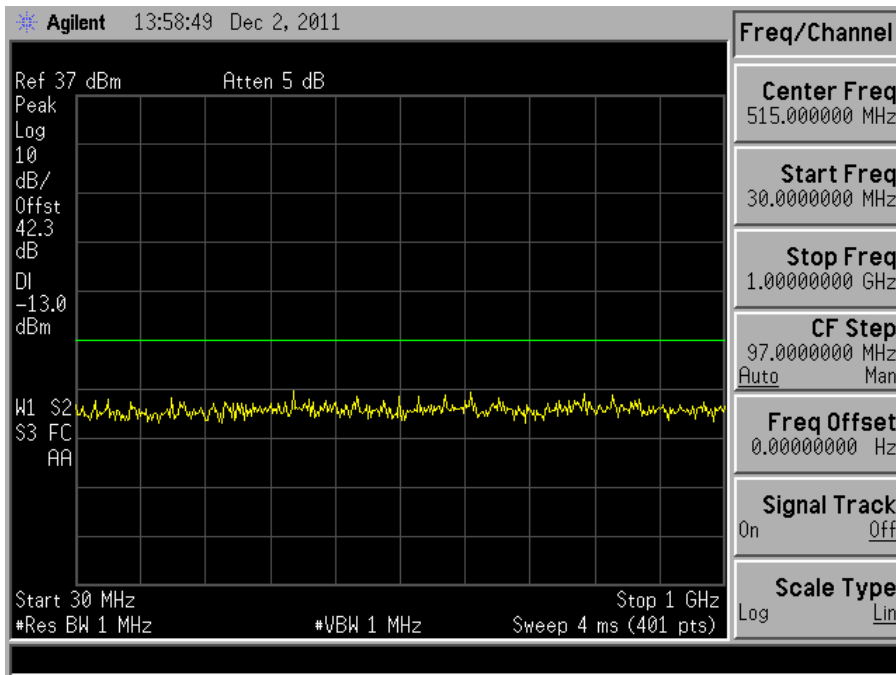

Fig. 8a
Spurious Emissions Compliance
30MHz – 1GHz
TX Mode = DVB-T
Emission: 6M0W7D

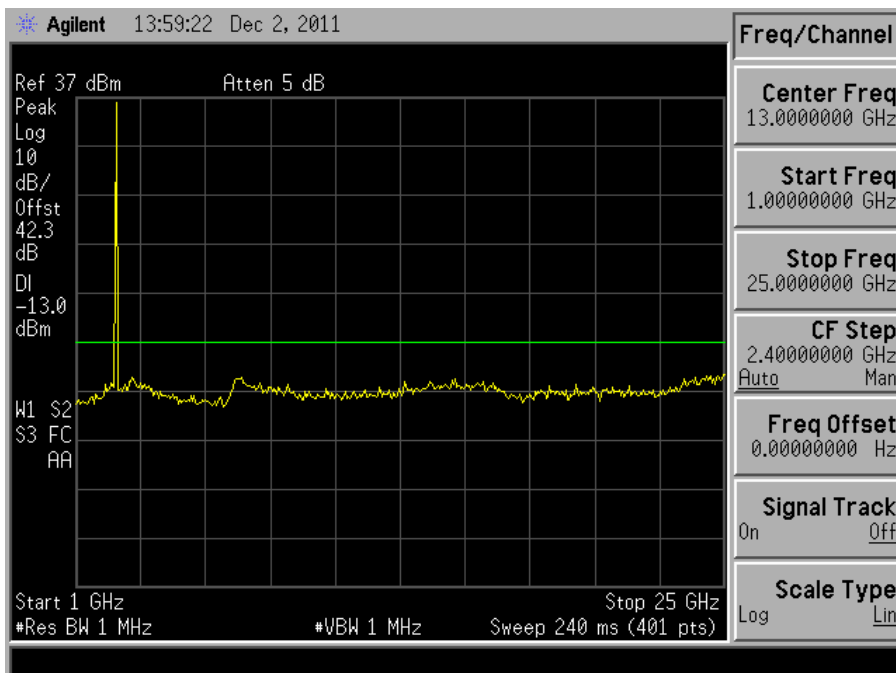

Fig. 8b
Spurious Emissions Compliance
1GHz – 25GHz
TX Mode = DVB-T
Emission: 6M0W7D

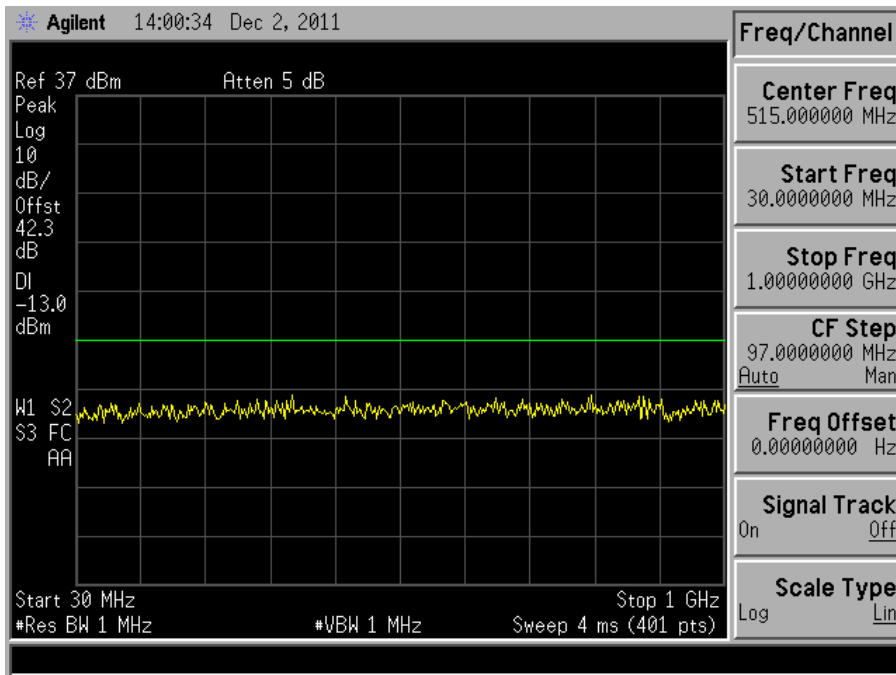

Fig. 9a
Spurious Emissions Compliance
30MHz - 1GHz
TX Mode = DVB-T
Emission: 7M0W7D

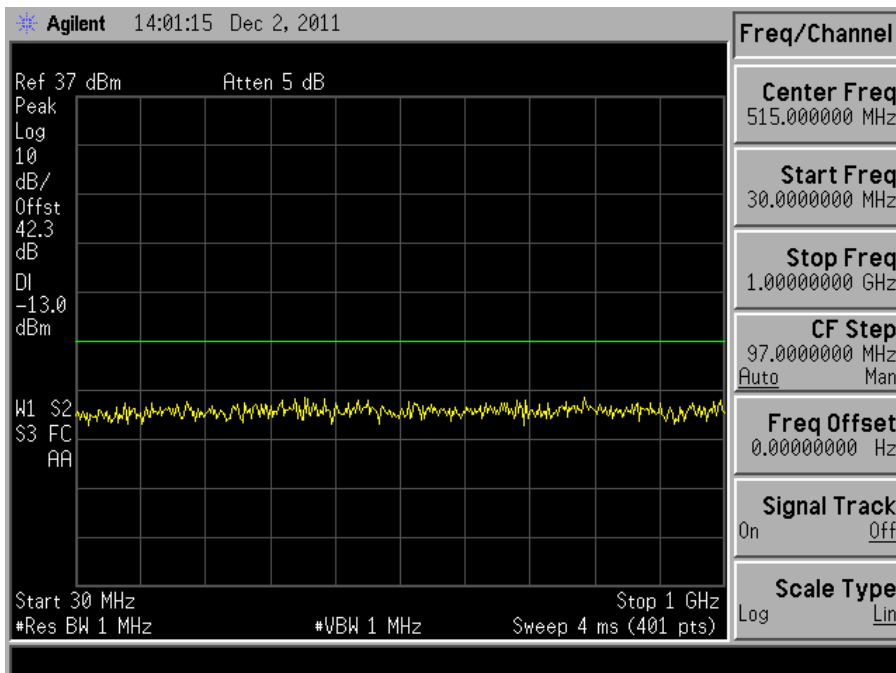

Fig. 9b
Spurious Emissions Compliance
1GHz - 25GHz
TX Mode = DVB-T
Emission: 7M0W7D

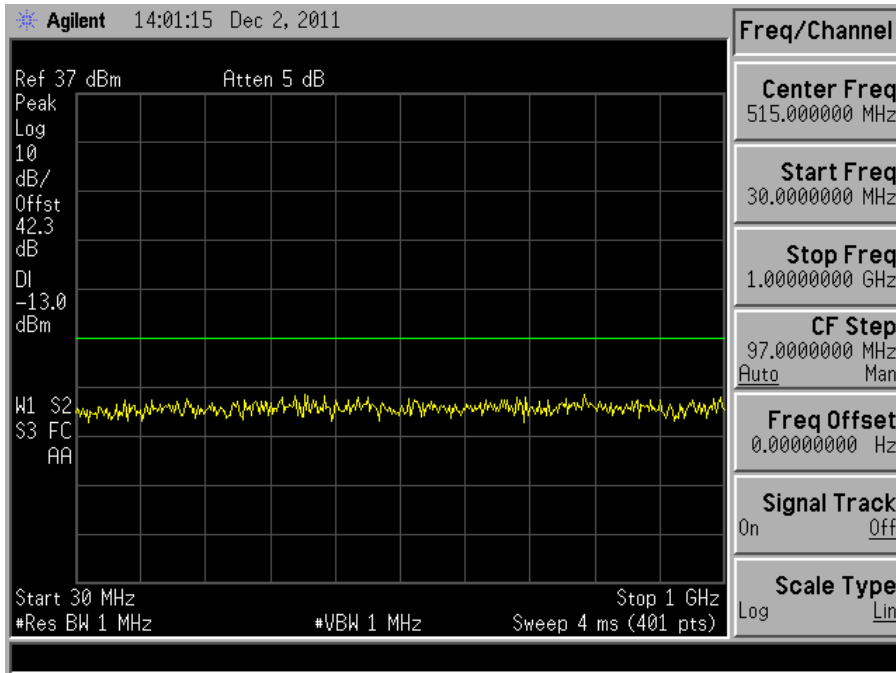

Fig. 10a
Spurious Emissions Compliance
30MHz – 1GHz
TX Mode = DVB-T
Emission: 8M0W7D

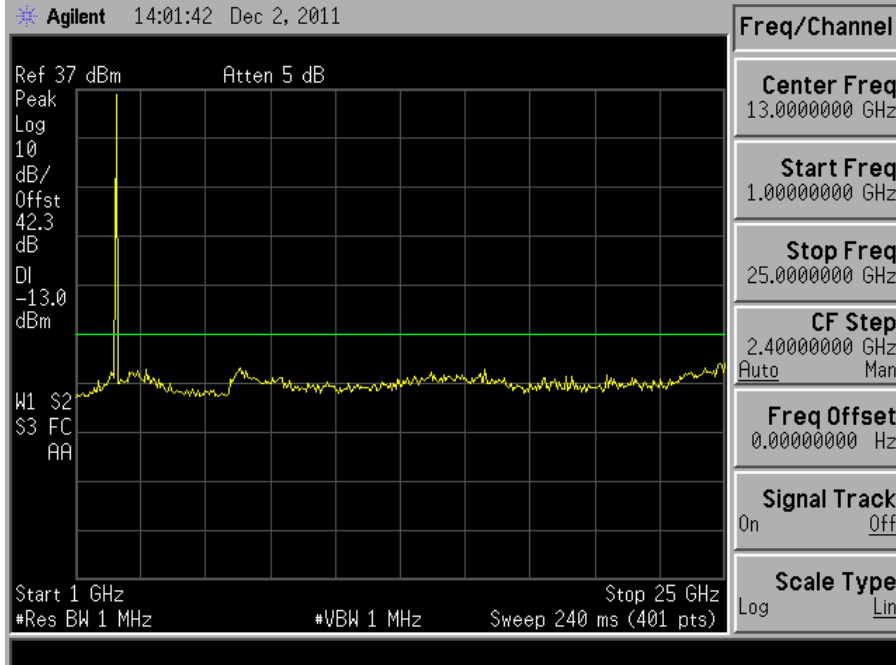

Fig. 10b
Spurious Emissions Compliance
1GHz – 25GHz
TX Mode = DVB-T
Emission: 8M0W7D

PD2-TX-5000-S Emission Masks

Test Method

For the purpose of calculating mask segments, the power of the un-modulated carrier was 1 Watt, therefore the value calculated per 90.210 (b) (3):

For the frequency region removed from the carrier by more than 250 percent of the authorized bandwidth, the emissions shall be less than:

$$P_{max}(dBc) = 43 + 10\log(1) = 43.0 \text{ dB}$$

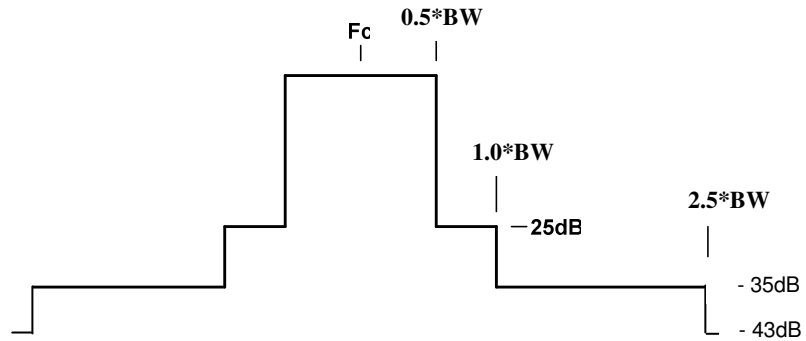

TX Mode	0.5*BW (MHz)	1.0*BW (MHz)	2.5*BW (MHz)
DOMO-N	0.625	1.25	2.5
DOMO-W	1.25	2.5	5.0
DVB-T-6	3.0	6.0	12
DVB-T-7	3.5	7.0	14
DVB-T-8	4.0	8.0	16

Figure 11
Mask Parameters for the Five TX Modes

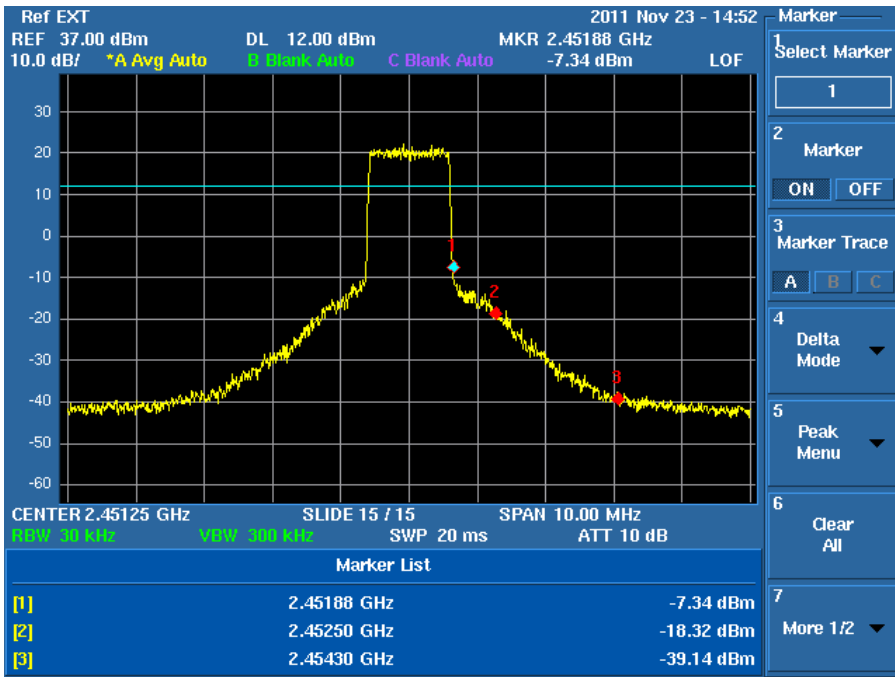

Fig. 12a
 Emission Mask Compliance
 TX Mode = DOMO-N
Emission: 1M3W7D
 Lower Band Edge

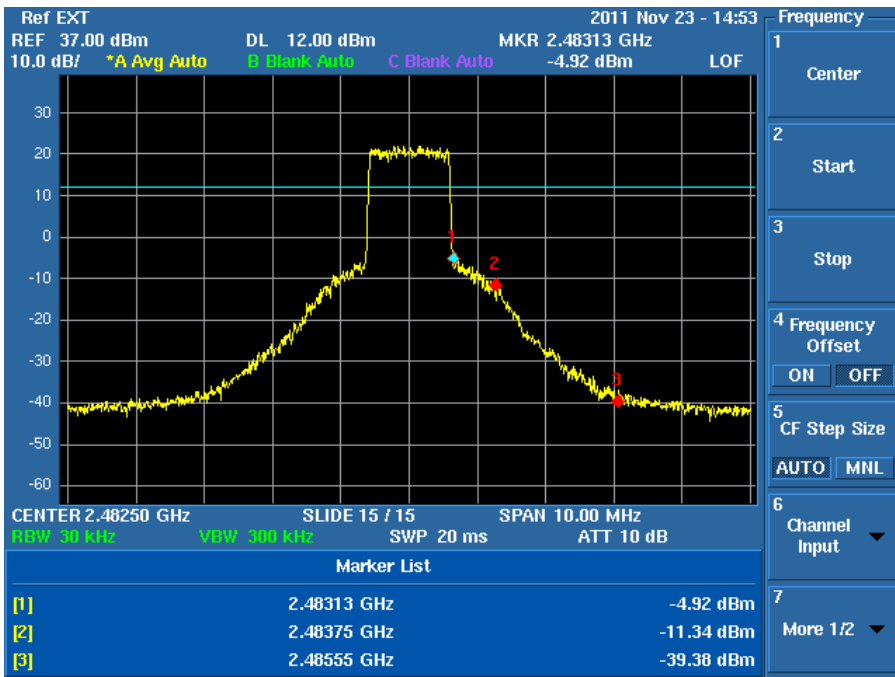

Fig. 12b
 Emission Mask Compliance
 TX Mode = DOMO-N
Emission: 1M3W7D
 Upper Band Edge

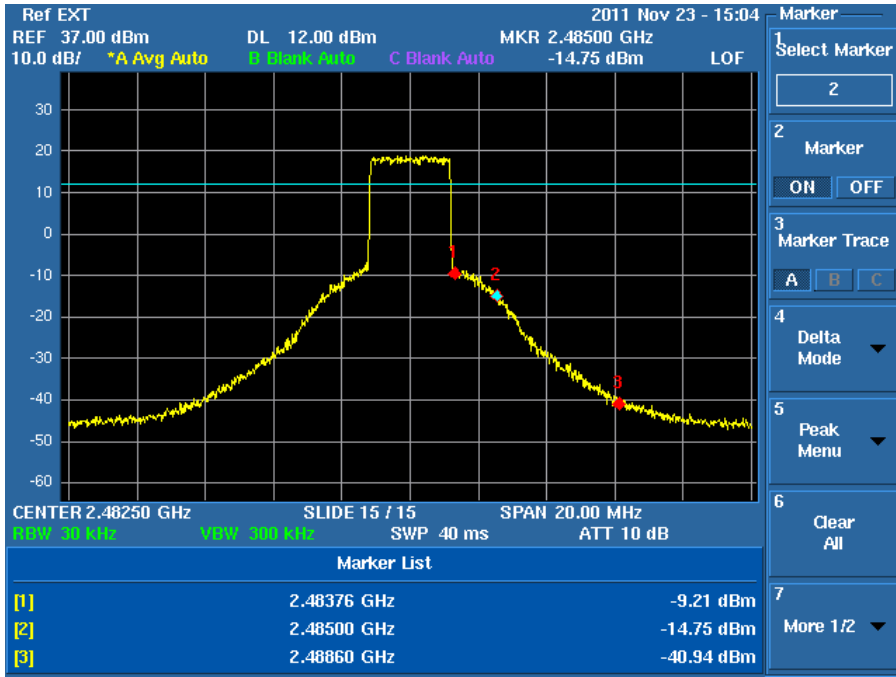

Fig. 13a
Emission Mask Compliance
TX Mode = DOMO-W
Emission: 2M5W7D
Lower Band Edge

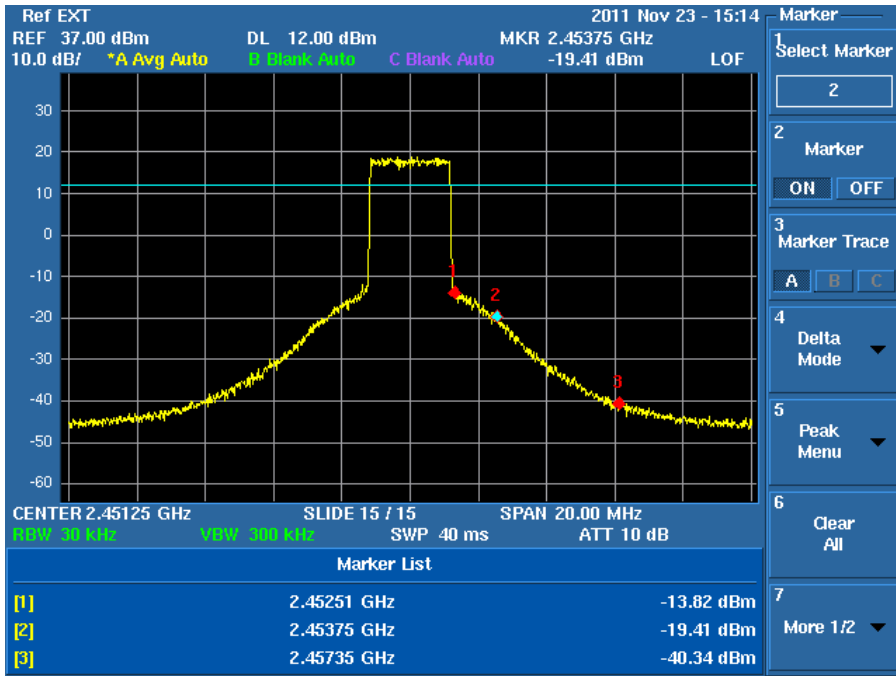

Fig. 13b
Emission Mask Compliance
TX Mode = DOMO-W
Emission: 2M5W7D
Upper Band Edge

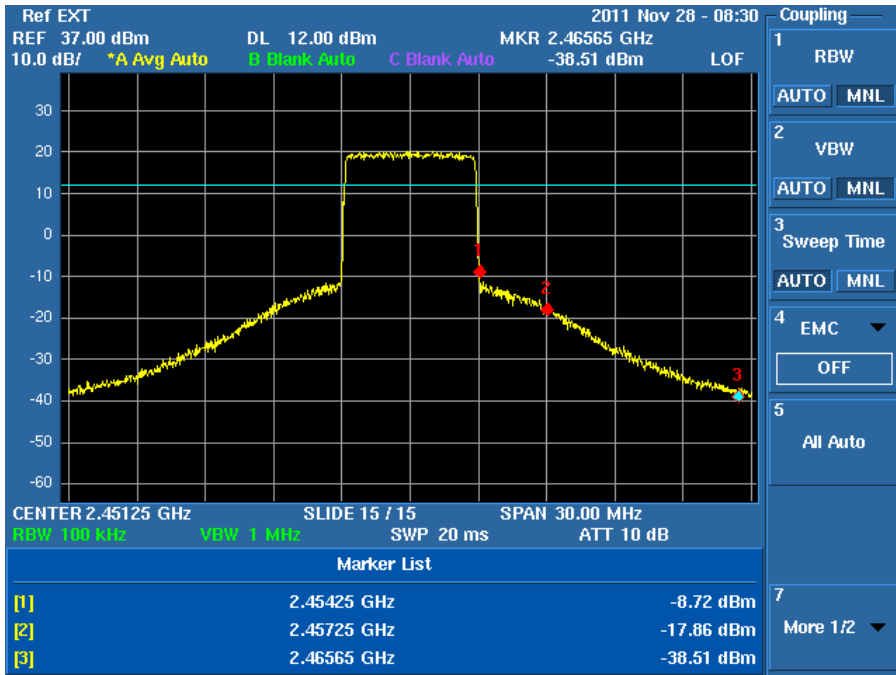

Fig. 14a
 Emission Mask Compliance
 TX Mode = DVB-T
Emission: 6M0W7D
 Lower Band Edge

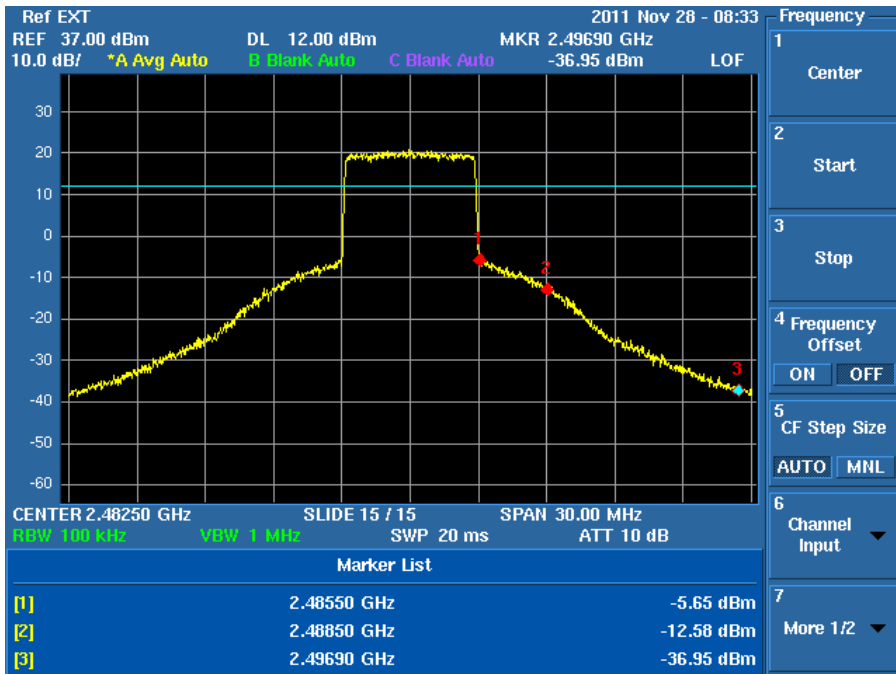

Fig. 14b
 Emission Mask Compliance
 TX Mode = DVB-T
Emission: 6M0W7D
 Upper Band Edge

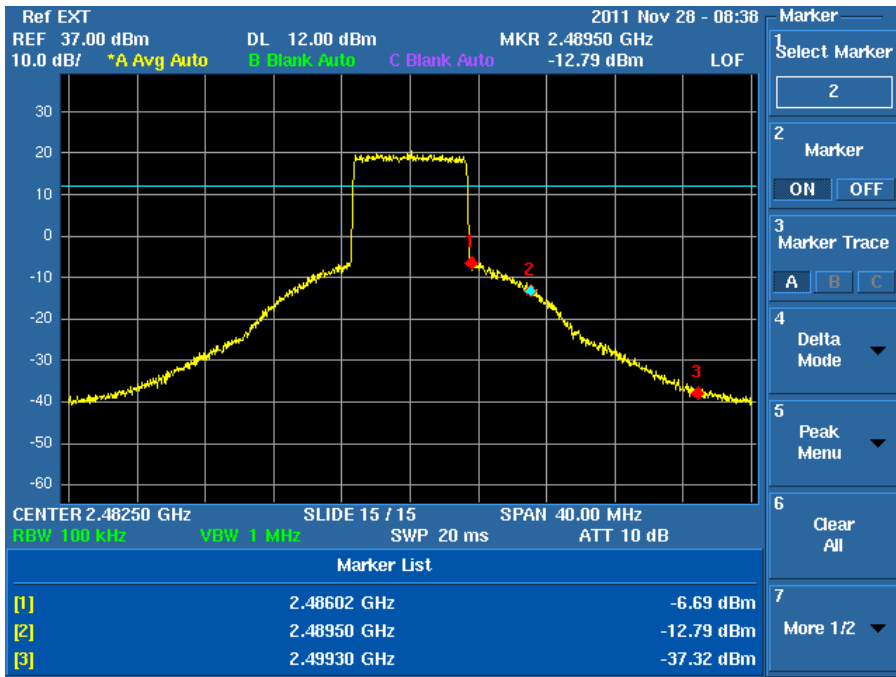

Fig. 15a
 Emission Mask Compliance
 TX Mode = DVB-T
Emission: 7M0W7D
 Lower Band Edge

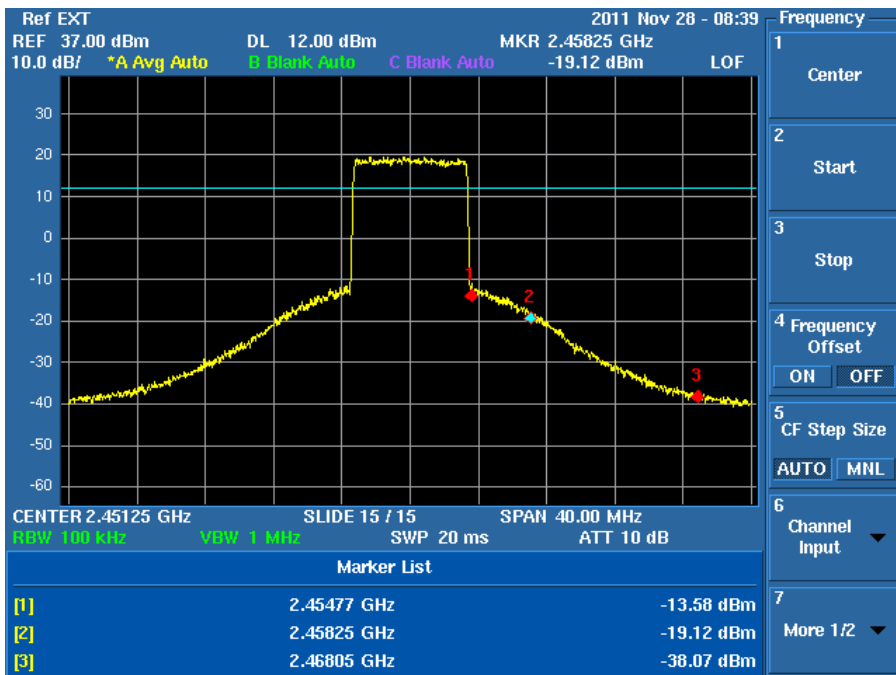

Fig. 15b
 Emission Mask Compliance
 TX Mode = DVB-T
Emission: 7M0W7D
 Lower Band Edge

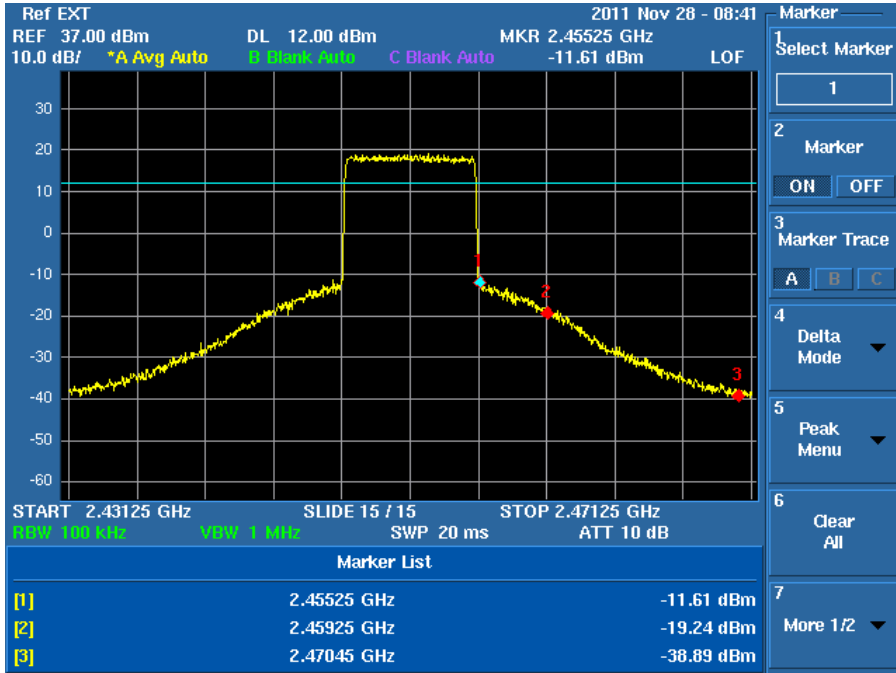

Fig. 16b
 Emission Mask Compliance
 TX Mode = DVB-T
Emission: 8M0W7D
 Upper Band Edge

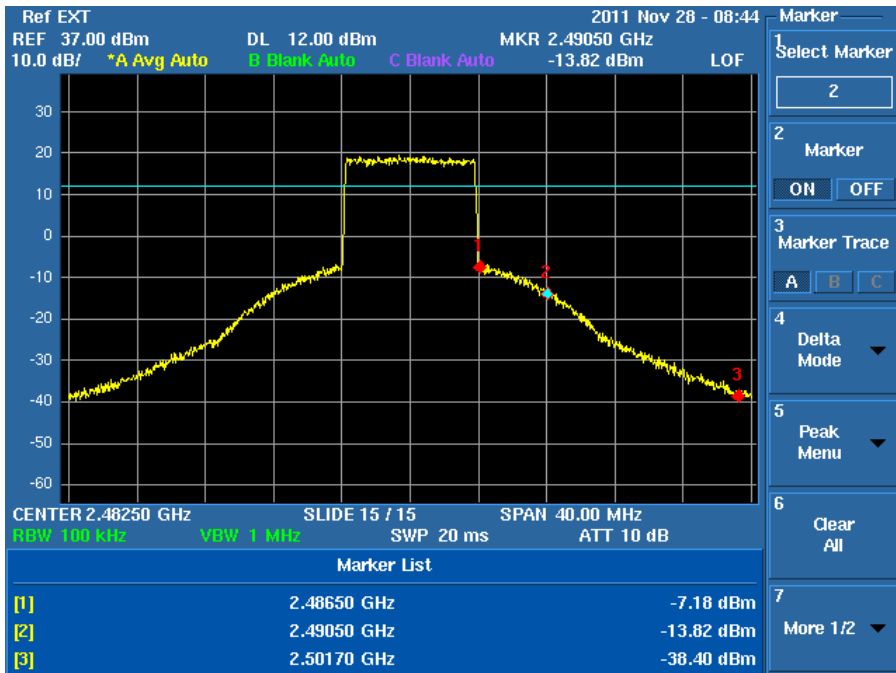

Fig. 16a
 Emission Mask Compliance
 TX Mode = DVB-T
Emission: 8M0W7D
 Lower Band Edge

PD2-TX-5000-S Frequency Stability - Temperature**Relevant FCC Chapter:**

2.1055 Measurements required: Frequency Stability.

(a) The frequency stability shall be measured with variation of ambient temperature as follows:

(1) From -30° to $+50^{\circ}$ centigrade for all equipment except that specified in paragraphs (a) (2) and (3) of this section.

[The PD2-TX-5000-S does not qualify under part 90, chapter 2.1055 (a) (2) or (a) (3)]

(b) Frequency measurements shall be made at the extremes of the specified temperature range and at intervals of not more than 10° centigrade through the range. A period of time sufficient to stabilize all of the components of the oscillator circuit at each temperature level shall be allowed prior to frequency measurement. The short term transient effects on the frequency of the transmitter due to keying (except for broadcast transmitters) and any heating element cycling normally occurring at each ambient temperature level also shall be shown. Only the portion or portions of the transmitter containing the frequency determining and stabilizing circuitry need be subjected to the temperature variation test.

Test Setup:

The setup for this test is shown below.

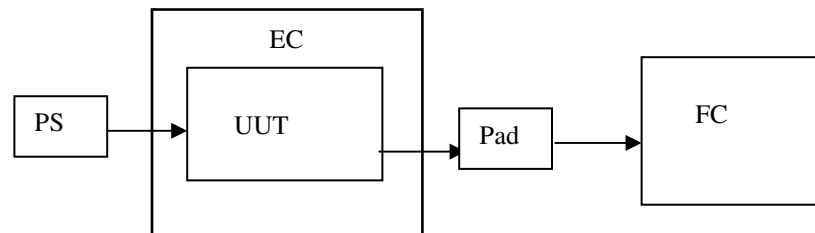

For specific test equipment details see supporting file:
DTC_PD2TX5000S_EquipList.PDF

PS - Power Supply: Item 1
 EC - Environmental Chamber: Item 14
 UUT - PD2-TX-5000-S, SN SB057279
 Pad - 20 dB Pad: Item 4
 FC - Frequency Counter: Item 15

Test Method:

The unit under test was powered at 15.0 VDC and set to a carrier frequency of 2.451 GHz. The digital modulation was disabled in order to allow the unit to transmit a single CW center frequency carrier. The Environmental Chamber was set to -30° C and swept to $+50^{\circ}$ C in 10° steps. Due to the small size of the chamber and the UUT, the unit was left at each temperature for 1 hour before the measurement was made. Since there is no method of keying the transmitter or any form of heating element in the UUT, those results are not required.

Test Results:

The results of the test are shown in Figures 17a and 17b.

**Figure 17a - Frequency Stability as a Function of Temperature
(Pursuant to FCC Requirement 2.1055a) - Raw Data**

PD2-TX-5000-S
SN SB057279

Temp (deg C.)	Frequency (Hz)	Deviation (ppm)
-30	2,466,000,612	0.25
-20	2,466,000,808	0.33
-10	2,466,000,976	0.40
0.0	2,466,000,694	0.28
+10	2,465,999,951	-0.02
+20	2,466,000,616	0.25
+30	2,465,999,999	0.00
+40	2,465,999,531	-0.19
+50	2,465,999,522	-0.19

**Figure 17b - Frequency Deviation as a Function of Temperature
(Pursuant to FCC Requirement 2.1055a)**

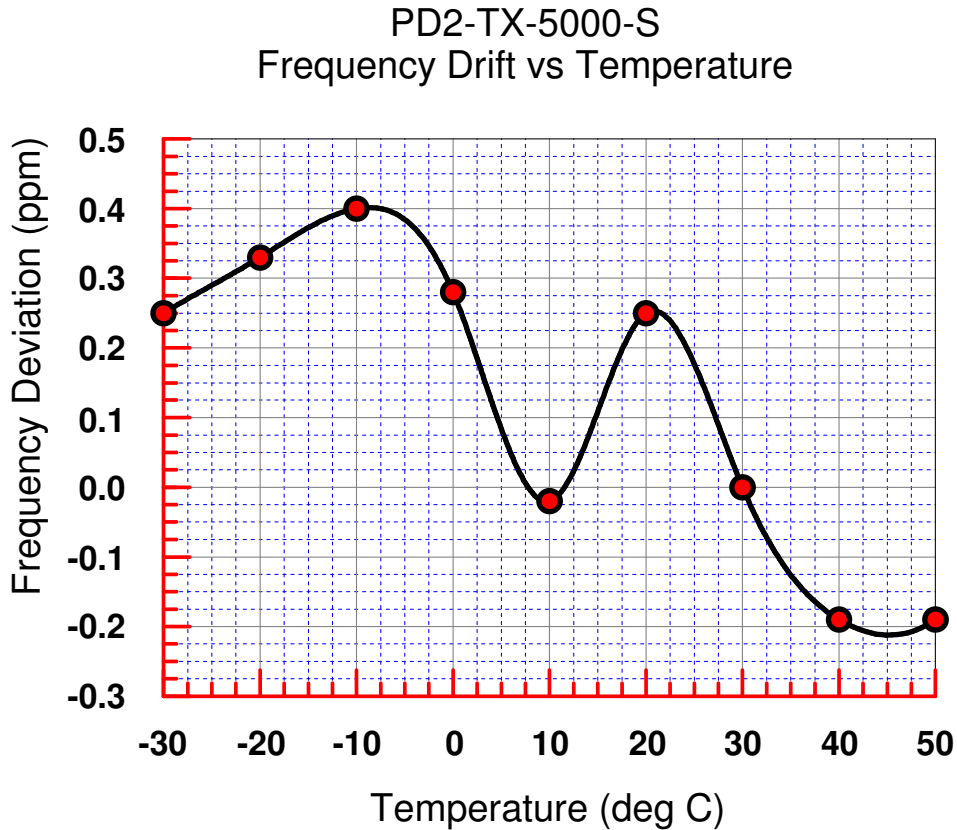

PD2-TX-5000-S Frequency Stability - Power Supply

Relevant FCC Chapter:

2.1055 Measurements required: Frequency Stability.

(d) The frequency stability shall be measured with variation of primary supply voltage as follows:

(1) Vary primary supply voltage from 85 to 115 percent of the nominal value for other than hand carried battery equipment.

Test Setup:

The setup for this test is shown below.

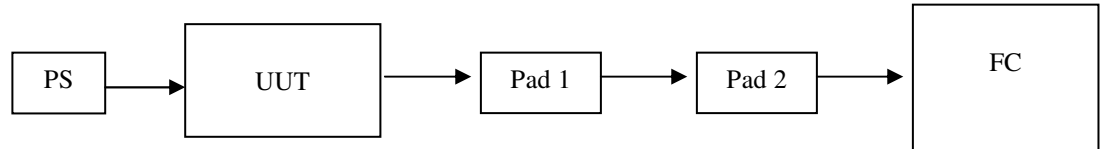

For specific test equipment details see supporting file:
DTC_PD2TX5000S_EquipList.PDF

- PS - Power Supply: Item 1
- UUT - PD2-TX-5000-S, SB057279
- Pad 1 - 20 dB Pad: Item 4
- Pad 2 - 20 dB Pad: Item 5
- FC - Frequency Counter: Item 15

Test Method:

The output frequency of the unit under test was measured at supply voltages between 10.2 VDC (12V x 85%) to 13.8 VDC (12V x 115%). The unit was placed in a mode which allowed a single carrier of integer frequency to be generated. A reference frequency of 2466.000 MHz was chosen.

Test Results: The results of the test are shown in Figures 18a and 18b.

Frequency Deviation (PPM) as a function of supply voltage

Figure 18a - Frequency Stability as a Function of Supply Voltage (Pursuant to FCC Requirement 2.1055d) - Raw Data

Vsupply (VDC)	Frequency Vs Supply Voltage Fc = 2,466.000,000 Hz	
	Frequency (Hz)	Deviation (PPM)
10.2	2,465,999,947	-0.022
12.0	2,466,000,058	0.024
13.8	2,466,000,027	0.011

NOTE: Nominal primary supply Voltage = 12.00 VDC

Figure 18b - Frequency Deviation (PPM), from 2,466,000,000 Hz, as a function of Supply Voltage (Pursuant to FCC Requirement 2.1055d)

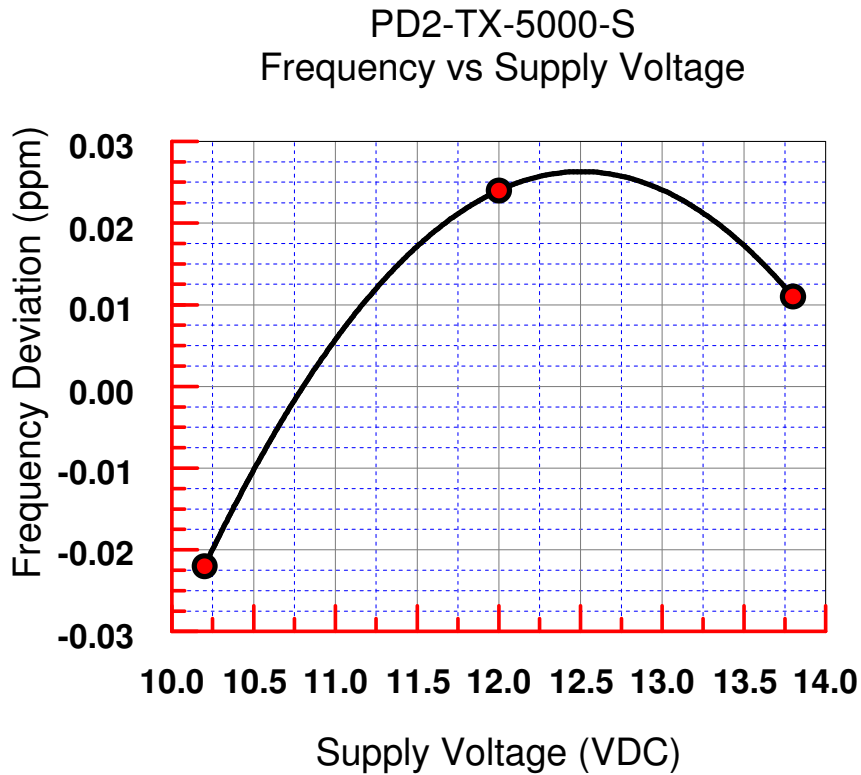

PD2-TX-5000-S SAR Testing**Relevant FCC Chapter:**

2.1093 Radiofrequency radiation exposure evaluation: portable devices.
2.1093

(c) Portable devices that operate in the Cellular Radiotelephone Service, the Personal Communications Service (PCS), the Satellite Communications Services, the General Wireless Communications Service, the Wireless Communications Service, the Maritime Services, the Specialized Mobile Radio Service, the 4.9 GHz Band Service, the Wireless Medical Telemetry Service (WMTS) and the Medical Implant Communications Service (MICS), authorized under subpart H of part 22 of this chapter, parts 24, 25, 26, 27, 80, and 90 of this chapter, subparts H and I of part 95 of this chapter, and unlicensed personal communication service, unlicensed NII devices and millimeter wave devices authorized under subparts D and E, §§15.253, 15.255 and 15.257 of this chapter are subject to routine environmental evaluation for RF exposure prior to equipment authorization or use. All other portable transmitting devices are categorically excluded from routine environmental evaluation for RF exposure prior to equipment authorization or use, except as specified in §§1.1307(c) and 1.1307(d) of this chapter.

The PD2-TX-5000-S operates in the services delineated by 2.1093 (c). However, the PD2-TX-5000-S is not designed for body-worn applications and, as such, the PD2-TX-5000-S Operator's Manual states that "a separation distance of at least 30 cm must be maintained between the antenna and the body of the user or nearby persons."

The antenna supplied with the PD2-TX-5000-S has a gain of 2.1dBi. The MPE (Maximum Permissible Exposure) calculation for the PD2-TX-5000-S, operating with this antenna, and the minimum body-antenna separation stated above (30cm), yields a Power Density of 0.72mW/cm². The limit for Maximum Permissible Exposure (MPE) (General Population) in the frequency band 1.50 - 100 GHz is 1 mW/cm² (47 CFR 1.1310).

The intended usage of the PD2-TX-5000-S and the resulting MPE level exempt the PD2-TX-5000-S from SAR testing and none was performed.

Spurious Radiated Emissions - 2.1053, 90.210(d)

Measurements performed by RETLIF TESTING LABS

ATTACHMENT FILE:

[14]H25PD2TX5000S_R-5558N.PDF