



FCC TEST REPORT

According to

FCC Rules and Regulations

Part 15 Subpart C

Applicant : Motorola, Inc.
Address : 46653 Frenont Blvd, Fremont, CA 94538
Equipment : Motorola 802.11n USB Adapter
Model No. : TER-NUSB1
FCC ID : GZ5TERNUSB1
Trade Name : Motorola

Laboratory Accreditation



- The test result refers exclusively to the test presented test model / sample.,
- Without written approval of **CerpPASS Technology Corp.**, the test report shall not be reproduced except in full.
- The EUT is also considered as a kind of computer peripheral, because the connection to computer is necessary for typical use. It has been verified to comply with the requirements of FCC Part 15, Subpart B, Class B (DoC). The test report has been issued separately.



Contents

1. Report of Measurements and Examinations	5
1.1 List of Measurements and Examinations	5
2. Test Configuration of Equipment under Test	6
2.1 Feature of Equipment under Test.....	6
2.2 Carrier Frequency of Channels	7
2.3 Test Mode and Test Software	8
2.4 Description of Test System.....	8
2.5 Connection Diagram of Test System.....	9
2.6 General Information of Test.....	10
2.7 Measurement Uncertainty	10
2.8 History of this test report	11
3. Antenna Requirements	12
3.1 Standard Applicable	12
3.2 Antenna Construction and Directional Gain.....	12
4. Test of Conducted Emission	13
4.1 Test Limit	13
4.2 Test Procedures	13
4.3 Typical Test Setup	14
4.4 Measurement Equipment.....	14
4.5 Test Result and Data	15
4.6 Test Photographs	27
5. Test of Radiated Emission	28
5.1 Test Limit	28
5.2 Test Procedures	28
5.3 Typical Test Setup	29
5.4 Measurement Equipment.....	29
5.5 Test Result and Data	30
5.6 Test Photographs	94
6. 6dB Bandwidth Measurement Data	95
6.1 Test Limit	95
6.2 Test Procedures	95
6.3 Test Setup Layout	95
6.4 Measurement Equipment.....	95
6.5 Test Result and Data	96
7. Maximum Peak Output Power	107
7.1 Test Limit	107
7.2 Test Procedures	107
7.3 Test Setup Layout	107
7.4 Measurement Equipment.....	107
7.5 Test Result and Data	107
8. Power Spectral Density	119
8.1 Test Limit	119
8.2 Test Procedures	119
8.3 Test Setup Layout	119



8.4 Measurement Equipment..... 119

8.5 Test Result and Data..... 120

9. Band Edges Measurement 131

9.1 Test Limit 131

9.2 Test Procedure 131

9.3 Test Setup Layout 131

9.4 Measurement Equipment..... 131

9.5 Test Result and Data..... 132

9.6 Restrict Band Emission Measurement Data 147

10. Restricted Bands of Operation 149

10.1 Labeling Requirement..... 149

Appendix A. Photographs of EUT.....A1 ~ A3



CERTIFICATE OF COMPLIANCE

According to

FCC Rules and Regulations

Part 15 Subpart C

Applicant : Motorola, Inc.
Address : 46653 Frenont Blvd, Fremont, CA 94538
Equipment : Motorola 802.11n USB Adapter
Model No. : TER-NUSB1
FCC ID : GZ5TERNUSB1

I HEREBY CERTIFY THAT :

The measurements shown in this test report were made in accordance with the procedures given in **ANSI C63.4** The equipment was **passed** the test performed according to **FCC Rules and Regulations Part 15 Subpart C (2005)**.

The test was carried out on Jun. 30, 2009 at CerpPASS Technology Corp.

Signature

Anson Chou
EMC/RF B.U. Vice General Manager



1. Report of Measurements and Examinations

1.1 List of Measurements and Examinations

FCC Rule	Description of Test	Result
15.203	. Antenna Requirement	Pass
15.207	. Conducted Emission	Pass
15.209 15.247(d)	. Radiated Emission	Pass
15.247(a)(2)	. 6dB Bandwidth	Pass
15.247(b)	. Maximum Peak Output Power	Pass
15.247(d)	. 100kHz Bandwidth of Frequency Band Edges	Pass
15.247(e)	. Power Spectral Density	Pass
1.1307 1.1310 2.1091 2.1093	. RF Exposure Compliance	Pass



2. Test Configuration of Equipment under Test

2.1. Feature of Equipment under Test

Standards:	IEEE802.11a, IEEE 802.11b, IEEE 802.11g, Draft 802.11n compliant
Computer Slot Type:	USB
Chipset:	Ralink RT2770(MAC/BB), RT2750(RF)
Tx:	1
Rx:	2
Operating Frequency:	2.4 ~ 2.4835 GHz 5.150~5.250GHz, 5.725~5.825GHz
Modulation Technique:	
Draft 802.11n:	BPSK, QPSK, 16-QAM, 64-QAM
802.11a/g:	OFDM
802.11b:	CCK,QPSK,BPSK
Media Access Protocol:	CSMA/CA
Operating Voltage:	5V +/- 5%
Transmit Power:	802.11n: 13.5 +/- 1 dBm 802.11a/g: 13.5 +/- 1 dBm 802.11b: 17 +/- 1 dBm
Security:	WPA/WPA2; 128-bit TKIP/AES encryption, 40/64-, 128-bit WEP shared-key encryption 802.1x, and EAP-TLS, and PEAP authentication
OS Requirements:	Windows Vista/XP
Antenna Type / Gain:	PCB Antenna / 3.89dBi PCB Antenna/ 1.73dBi

2.2. Carrier Frequency of Channels

802.11a, 802.11an HT20 (5150 ~ 5250MHz)

Channel	Frequency(MHz)	Channel	Frequency(MHz)
36	5180	48	5240
40	5200	---	---
44	5220	---	---

802.11 an HT40 (5150 ~ 5250MHz)

Channel	Frequency(MHz)	Channel	Frequency(MHz)
38	5190	46	5230
42	5210	---	---



2.2 Carrier Frequency of Channels

802.11b, 802.11g, 802.11n HT 20 (2412 ~ 2462MHz)

Channel	Frequency(MHz)	Channel	Frequency(MHz)
01	2412	07	2442
02	2417	08	2447
03	2422	09	2452
04	2427	10	2457
05	2432	11	2462
06	2437	---	---

802.11n HT40 (2422 ~ 2462MHz)

Channel	Frequency(MHz)	Channel	Frequency(MHz)
---	---	07	2442
---	---	08	2447
03	2422	09	2452
04	2427	---	---
05	2432	---	---
06	2437	---	---

802.11a, 802.11an HT20 (5725 ~ 5850MHz)

Channel	Frequency(MHz)	Channel	Frequency(MHz)
149	5745	161	5805
153	5765	165	5825
157	5785	---	---

802.11an HT 40 (5725 ~ 5850MHz)

Channel	Frequency(MHz)	Channel	Frequency(MHz)
151	5755	159	5795
155	5775	---	---



2.3 Test Mode and Test Software

- a. During testing, the interface cables and equipment positions were varied according to ANSI C63.4.
- a. The complete test system included remote workstation, PC, Monitor, Keyboard, Mouse, Modem, Printer and EUT for EMI test. The remote workstation includes Notebook.
- b. An executive program, "Ping.exe" under WIN XP, which transmits and receives data to the remote workstation through Wireless.
- c. The following test modes were performed for test:
 - 802.11b/g/n HT20: CH01: 2412MHz, CH06: 2437MHz, CH11: 2462MHz
 - 802.11n HT40: CH03: 2422MHz, CH06: 2437MHz, CH09: 2452MHz
 - 802.11a/an HT20: CH 149: 5745MHz, CH 157: 5785MHz, CH 165: 5825MHz
 - 802.11an HT40: CH 159: 5795MHz

2.4 Description of Test System

Device	Manufacturer	Model No.	Description
PC	IBM	IGV	Power Cable, Unshielding 1.8 m
Monitor	ViewSonic	G90fB	Power Cable, Adapter Unshielding 1.8 m Data Cable, VGA Shielding 1.35 m
Keyboard	IBM	KB-0225	Data Cable, PS2 Shielding 1.85 m
Mouse	IBM	MU29J	Data Cable, PS2 Shielding 1.85 m
Modem	ACEXX	DM-1414	Power Cable, Adapter Unshielding 1.8 m Data Cable, RS232 Shielding 1.35 m
Printer	HP	Desk Jet 400	Power Cable, Adapter Unshielding 1.8 m Data Cable, Print Shielding 1.6 m
Remote Workstation			
Notebook	TOSHIBA	PSA50T-05M00C	Power Cable, Adapter Unshielding 1.8 m



2.5 Connection Diagram of Test System

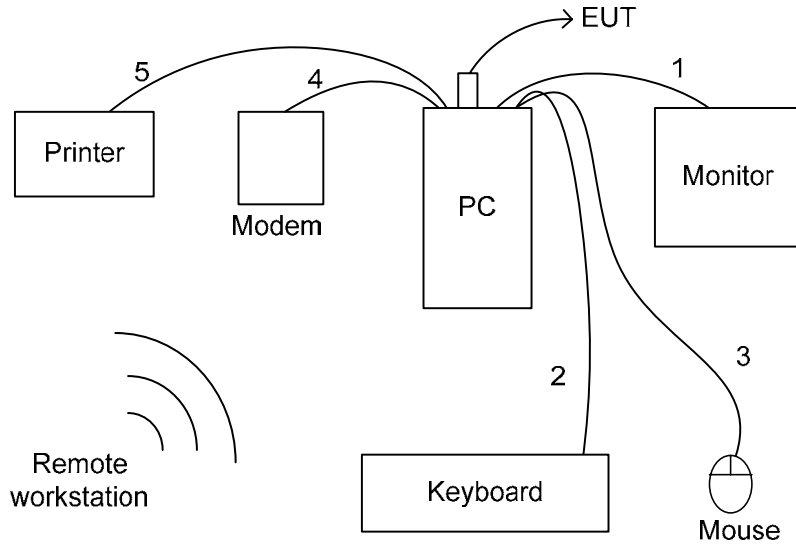

1. The VGA cable is connected from PC to the Monitor.
 2. The PS2 cable is connected from PC to the PS2 Keyboard.
 3. The PS2 cable is connected from PC to the PS2 Mouse.
 4. The RS232 cable is connected from PC to the Modem.
 5. The Print cable is connected from PC to the Printer.
- * The EUT keeps to transmit and receive data to remote workstation by Wireless.



2.6 General Information of Test

Test Site :	CerpPASS Technology Corp. 2F-11, No. 3, Yuan Qu St., (Nankang Software Park), Taipei, Taiwan 115, R.O.C.
Test Site Location (OATS1-SD):	No. 7-2, Moshihkeng, Fongtian Village, Shihding Township, Taipei County, Taiwan, R.O.C.
FCC Registration Number :	TW1049, 488071, 982971
IC Registration Number :	4934C-1, 4934D-1
VCCI Registration Number :	T-543 for Telecommunication Test C-3328 for Conducted emission test R-3013 for Radiated emission test
Test Voltage:	AC 120V
Test in Compliance with:	ANSI C63.4-2003 FCC Part 15 Subpart C
Frequency Range Investigated:	Conducted: from 150kHz to 30MHz Radiation: from 30MHz to 40,000MHz
Test Distance:	The test distance of radiated emission from antenna to EUT is 3 M.

2.7 Measurement Uncertainty

Measurement Item	Measurement Frequency	Polarization	Uncertainty
Conducted Emission	9 kHz ~ 30 MHz	LINE/NEUTRAL	2.71 dB
Radiated Emission	30 MHz ~ 40GHz	Vertical	4.11 dB
		Horizontal	4.10 dB
6 dB Bandwidth	---	---	7500 Hz
Maximum Peak Output Power	---	---	1.4 dB
100kHz Bandwidth of Frequency Band Edges	---	---	2.2 dB
Power Spectral Density	---	---	2.2 dB



2.8 History of this test report

ORIGINAL.

Additional attachment as following record:

Attachment No.	Issue Date	Description



3. Antenna Requirements

3.1 Standard Applicable

For intentional device, according to FCC 47 CFR Section 15.203, an intentional radiator shall be designed to ensure that no antenna other than that furnished by the responsible party shall be used with the device.

And according to FCC 47 CFR Section 15.247 (b), if transmitting antennas of directional gain greater than 6dBi are used, the power shall be reduced by the amount in dB that the directional gain of the antenna exceeds 6dBi.

3.2 Antenna Construction and Directional Gain

Antenna 1: PCB Antenna, 3.89 dBi (2.4GHz Band)

Antenna 2: PCB Antenna, 1.73 dBi (5GHz Band)



4. Test of Conducted Emission

4.1 Test Limit

Conducted Emissions were measured from 150 kHz to 30 MHz with a bandwidth of 9 KHz on the 120 VAC power and return leads of the EUT according to the methods defined in ANSI C63.4-2003 Section 3.1. The EUT was placed on a nonmetallic stand in a shielded room 0.8 meters above the ground plane as shown in section 2.2. The interface cables and equipment positioning were varied within limits of reasonable applications to determine the position produced maximum conducted emissions.

Frequency (MHz)	Quasi Peak (dB μ V)	Average (dB μ V)
0.15 – 0.5	66-56*	56-46*
0.5 – 5.0	56	46
5.0 – 30.0	60	50

*Decreases with the logarithm of the frequency.

4.2 Test Procedures

- a. The EUT was placed 0.4 meter from the conducting wall of the shielding room was kept at least 80 centimeters from any other grounded conducting surface.
- b. Connect EUT to the power mains through a line impedance stabilization network (LISN).
- c. All the support units are connecting to the other LISN.
- d. The LISN provides 50 ohm coupling impedance for the measuring instrument.
- e. The FCC states that a 50 ohm, 50 micro-Henry LISN should be used.
- f. Both sides of AC line were checked for maximum conducted interference.
- g. The frequency range from 150 kHz to 30 MHz was searched.
- h. Set the test-receiver system to Peak Detect Function and Specified Bandwidth with Maximum Hold Mode.



4.3 Typical Test Setup

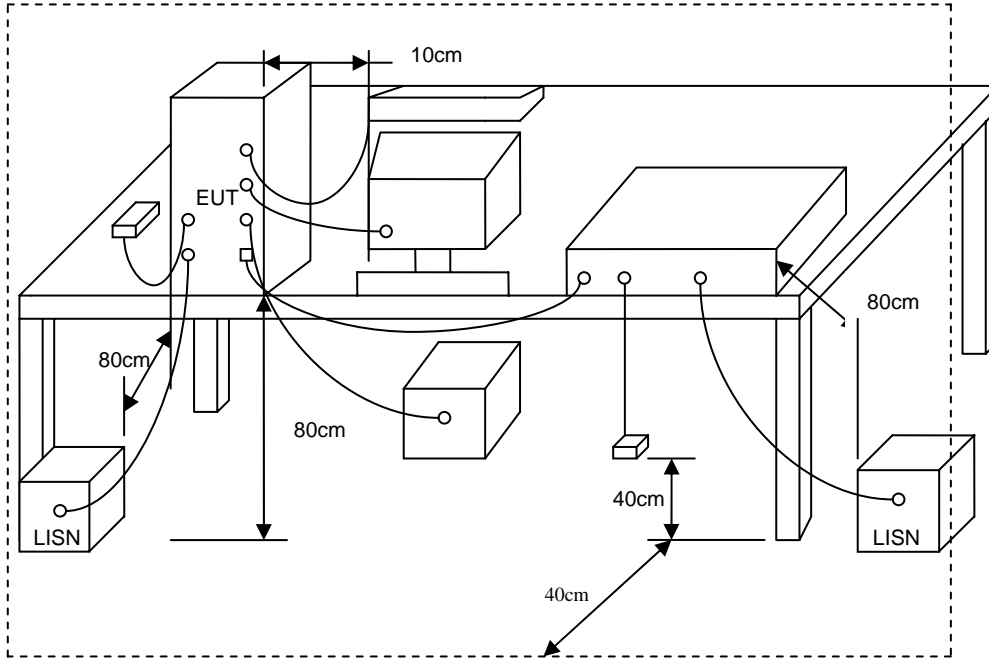

4.4 Measurement Equipment

Instrument/ Ancillary	Model No.	Manufacturer	Serial No.	Calibration Date	Valid Date.
EMI Receiver	R&S	ESCI	100443	2008/09/27	2009/09/26
LISN	NSLK 8127	Schwarzbeck	8127-516	2009/05/15	2010/05/14
LISN	Rolf Heine	NNB-2/16Z	03/10058	2009/04/18	2010/04/17



4.5 Test Result and Data

Power	: AC 120V	Pol/Phase	: LINE
Test Mode	: 802.11g, CH1	Temperature	: 25 °C
Memo	:	Humidity	: 56 %

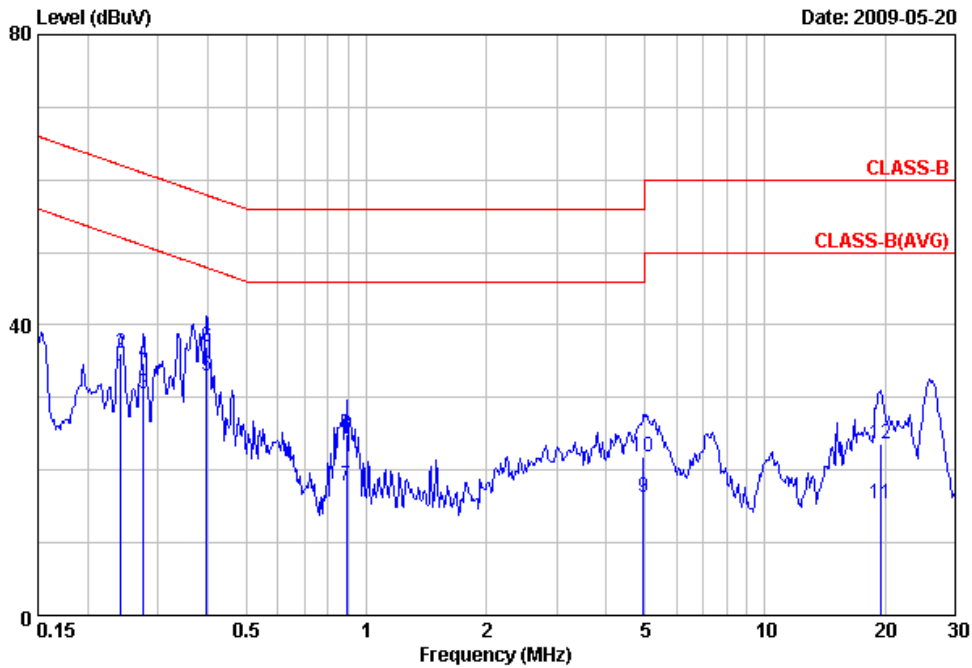

Item	Freq	Read Value	Factor	Result	Limit	Margin	Remark
	MHz	dBuV/m	dB	dBuV/m	dBuV/m	dB	
1	0.24	32.65	0.09	32.74	52.04	-19.30	Average
2	0.24	36.04	0.09	36.13	62.04	-25.91	QP
3	0.28	30.46	0.09	30.55	50.94	-20.39	Average
4	0.28	34.59	0.09	34.68	60.94	-26.26	QP
5	0.40	32.87	0.08	32.95	47.90	-14.95	Average
6	0.40	36.97	0.08	37.05	57.90	-20.85	QP
7	0.89	17.76	0.11	17.87	46.00	-28.13	Average
8	0.89	24.75	0.11	24.86	56.00	-31.14	QP
9	4.95	15.97	0.21	16.18	46.00	-29.82	Average
10	4.95	21.60	0.21	21.81	56.00	-34.19	QP
11	19.43	15.10	0.23	15.33	50.00	-34.67	Average
12	19.43	23.48	0.23	23.71	60.00	-36.29	QP

Notes:

1. Result = Read Value + Factor
2. Factor = LISN(ISN)Factor + Cable Loss
3. All emission below 1GHz at 802.11b/g mode are all the same,so the 802.11g mode chosen as representative in final test.
4. According to technical experiences,all spurious emission of 802.11g mode at channel 1,6,11 are almost the same below 1GHz,so that the channel 1 was chosen as representative in final test.
5. The data is worse case.



Power	: AC 120V	Pol/Phase	: NEUTRAL
Test Mode	: 802.11g, CH1	Temperature	: 25 °C
Memo	:	Humidity	: 56 %

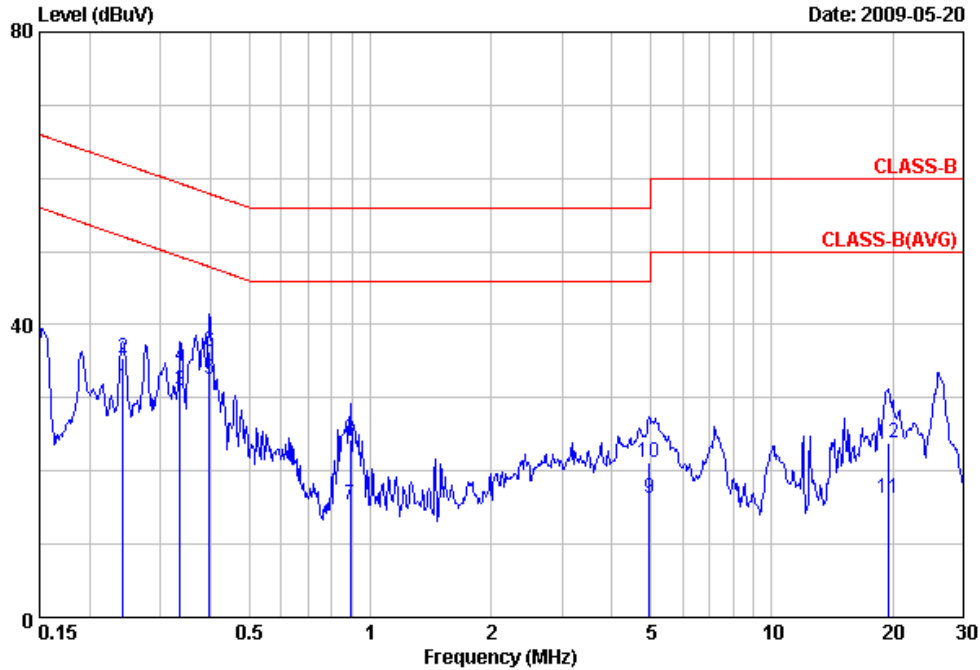

Item	Freq MHz	Read		Result dBuV/m	Limit dBuV/m	Margin dB	Remark
		Value dBuV/m	Factor dB				
1	0.24	31.30	0.11	31.41	52.04	-20.63	Average
2	0.24	35.42	0.11	35.53	62.04	-26.51	QP
3	0.34	30.80	0.11	30.91	49.31	-18.40	Average
4	0.34	34.10	0.11	34.21	59.31	-25.10	QP
5	0.40	32.42	0.11	32.53	47.90	-15.37	Average
6	0.40	36.17	0.11	36.28	57.90	-21.62	QP
7	0.89	15.19	0.13	15.32	46.00	-30.68	Average
8	0.89	24.09	0.13	24.22	56.00	-31.78	QP
9	4.95	16.04	0.20	16.24	46.00	-29.76	Average
10	4.95	21.04	0.20	21.24	56.00	-34.76	QP
11	19.43	15.83	0.39	16.22	50.00	-33.78	Average
12	19.43	23.52	0.39	23.91	60.00	-36.09	QP

Notes:

1. Result = Read Value + Factor
2. Factor = LISN(ISN)Factor + Cable Loss
3. All emission below 1GHz at 802.11b/g mode are all the same,so the 802.11g mode chosen as representative in final test.
4. According to technical experiences,all spurious emission of 802.11g mode at channel 1,6,11 are almost the same below 1GHz,so that the channel 1 was chosen as representative in final test.
5. The data is worse case.



Power	: AC 120V	Pol/Phase	: LINE
Test Mode	: 802.11n HT20, CH1	Temperature	: 25 °C
Memo	:	Humidity	: 56 %

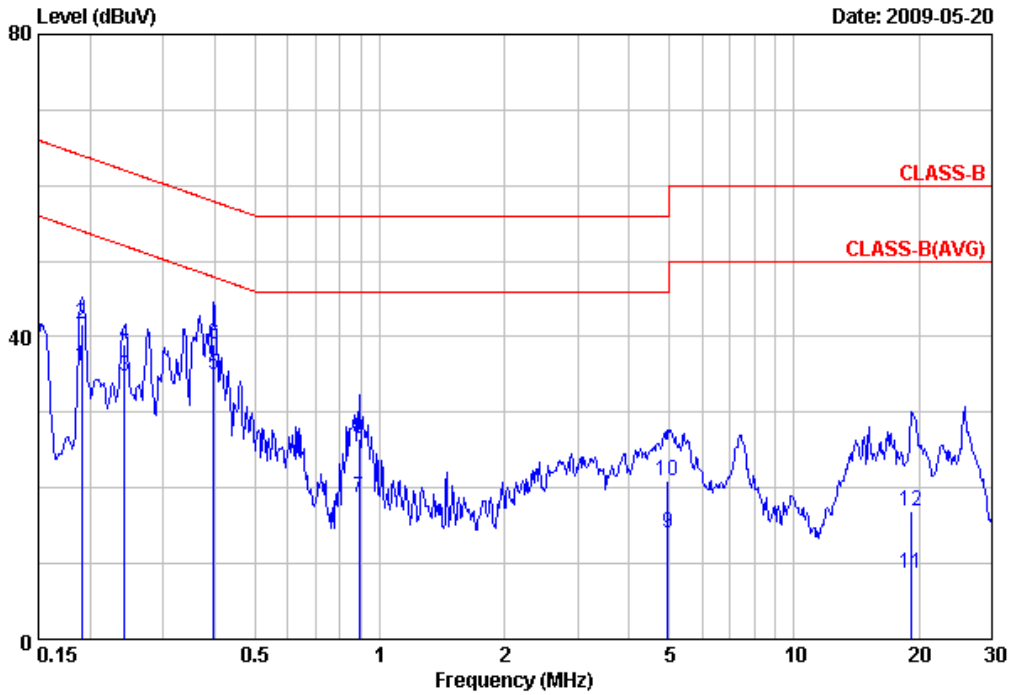

Item	Freq	Read Value	Factor	Result	Limit	Margin	Remark
	MHz	dBuV/m	dB	dBuV/m	dBuV/m	dB	
1	0.19	36.12	0.09	36.21	54.02	-17.81	Average
2	0.19	41.63	0.09	41.72	64.02	-22.30	QP
3	0.24	34.77	0.09	34.86	52.04	-17.18	Average
4	0.24	38.82	0.09	38.91	62.04	-23.13	QP
5	0.40	34.90	0.08	34.98	47.90	-12.92	Average
6	0.40	38.89	0.08	38.97	57.90	-18.93	QP
7	0.89	18.53	0.11	18.64	46.00	-27.36	Average
8	0.89	26.37	0.11	26.48	56.00	-29.52	QP
9	4.95	13.92	0.21	14.13	46.00	-31.87	Average
10	4.95	20.70	0.21	20.91	56.00	-35.09	QP
11	19.22	8.49	0.23	8.72	50.00	-41.28	Average
12	19.22	16.63	0.23	16.86	60.00	-43.14	QP

Notes:

1. Result = Read Value + Factor
2. Factor = LISN(ISN)Factor + Cable Loss
3. According to technical experiences, all spurious emission of 802.11MIMO mode at channel 1,6,11 are almost the same below 1GHz, so that the channel 1 was chosen as representative in final test.
4. The data is worse case.



Power	: AC 120V	Pol/Phase	: NEUTRAL
Test Mode	: 802.11n HT20, CH1	Temperature	: 25 °C
Memo	:	Humidity	: 56 %

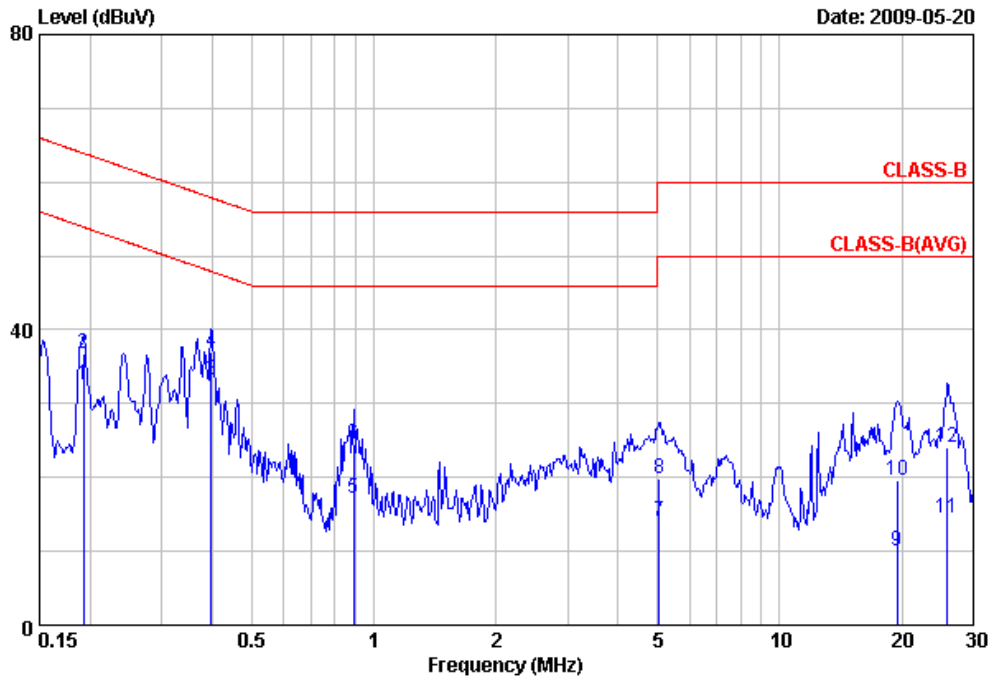

Item	Freq	Read Value	Factor	Result	Limit	Margin	Remark
	MHz	dBuV/m	dB	dBuV/m	dBuV/m	dB	
1	0.19	32.33	0.12	32.45	53.93	-21.48	Average
2	0.19	36.67	0.12	36.79	63.93	-27.14	QP
3	0.40	33.04	0.11	33.15	47.90	-14.75	Average
4	0.40	36.96	0.11	37.07	57.90	-20.83	QP
5	0.89	17.06	0.13	17.19	46.00	-28.81	Average
6	0.89	24.43	0.13	24.56	56.00	-31.44	QP
7	5.06	13.89	0.20	14.09	50.00	-35.91	Average
8	5.06	19.71	0.20	19.91	60.00	-40.09	QP
9	19.43	9.71	0.39	10.10	50.00	-39.90	Average
10	19.43	19.32	0.39	19.71	60.00	-40.29	QP
11	25.86	14.09	0.36	14.45	50.00	-35.55	Average
12	25.86	23.73	0.36	24.09	60.00	-35.91	QP

Notes:

1. Result = Read Value + Factor
2. Factor = LISN(ISN)Factor + Cable Loss
3. According to technical experiences, all spurious emission of 802.11MIMO mode at channel 1,6,11 are almost the same below 1GHz, so that the channel 1 was chosen as representative in final test.
4. The data is worse case.



Power	: AC 120V	Pol/Phase	: LINE
Test Mode	: 802.11n HT40, CH3	Temperature	: 25 °C
Memo	:	Humidity	: 56 %

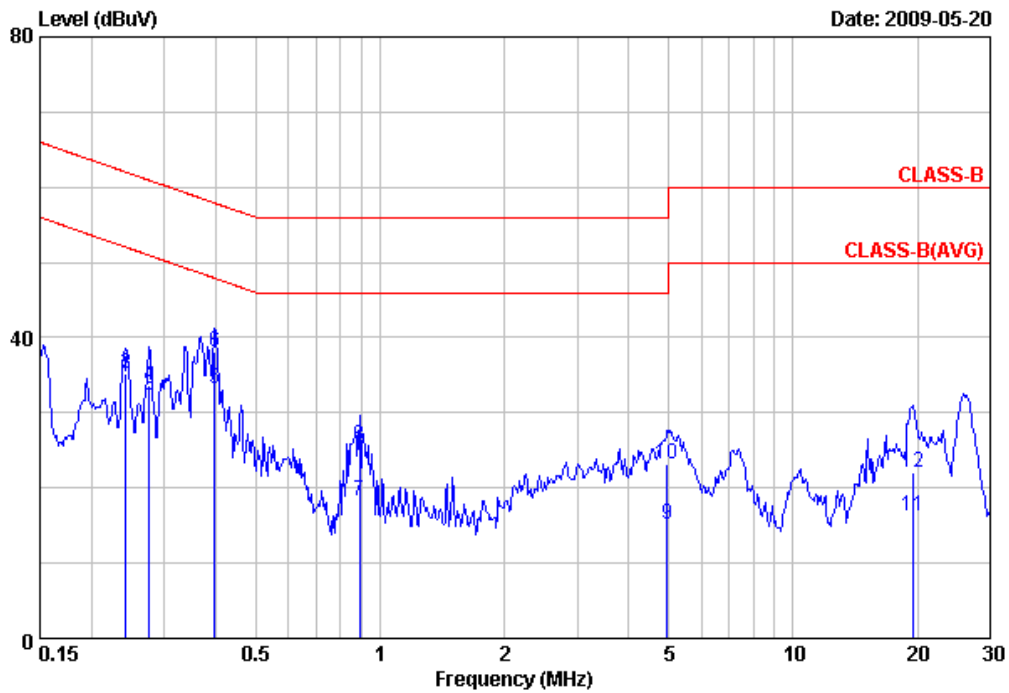

Item	Freq	Read Value	Factor	Result	Limit	Margin	Remark
	MHz	dBuV/m	dB	dBuV/m	dBuV/m	dB	
1	0.24	34.65	0.09	34.74	52.04	-17.30	Average
2	0.24	35.03	0.09	35.12	62.04	-26.92	QP
3	0.28	32.11	0.09	32.20	50.94	-18.74	Average
4	0.28	33.59	0.09	33.68	60.94	-27.26	QP
5	0.40	33.15	0.08	33.23	47.90	-14.67	Average
6	0.40	37.97	0.08	38.05	57.90	-19.85	QP
7	0.89	18.14	0.11	18.25	46.00	-27.75	Average
8	0.89	25.51	0.11	25.62	56.00	-30.38	QP
9	4.95	15.02	0.21	15.23	46.00	-30.77	Average
10	4.95	23.02	0.21	23.23	56.00	-32.77	QP
11	19.43	16.08	0.23	16.31	50.00	-33.69	Average
12	19.43	21.77	0.23	22.00	60.00	-38.00	QP

Notes:

1. Result = Read Value + Factor
2. Factor = LISN(ISN)Factor + Cable Loss
3. According to technical experiences, all spurious emission of 802.11MIMO mode at channel 3,6,9 are almost the same below 1GHz, so that the channel 3 was chosen as representative in final test.
4. The data is worse case.



Power	: AC 120V	Pol/Phase	: NEUTRAL
Test Mode	: 802.11n HT40, CH3	Temperature	: 25 °C
Memo	:	Humidity	: 56 %

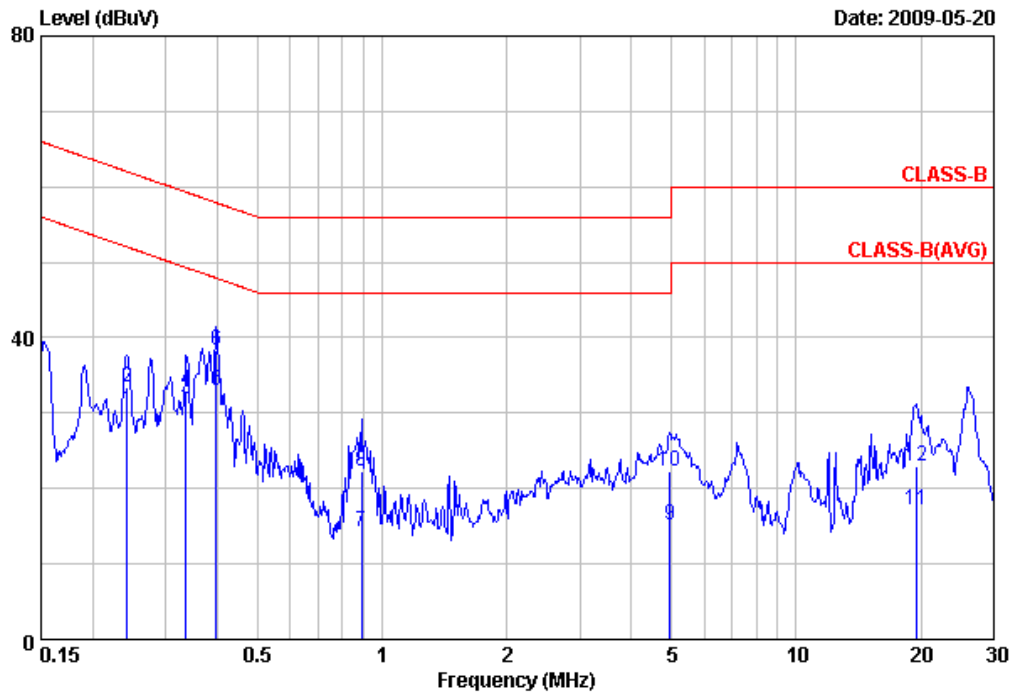

Item	Freq MHz	Read Value dBuV/m	Factor dB	Result dBuV/m	Limit dBuV/m	Margin dB	Remark
1	0.24	30.21	0.11	30.32	52.04	-21.72	Average
2	0.24	33.21	0.11	33.32	62.04	-28.72	QP
3	0.34	31.80	0.11	31.91	49.31	-17.40	Average
4	0.34	32.91	0.11	33.02	59.31	-26.29	QP
5	0.40	32.92	0.11	33.03	47.90	-14.87	Average
6	0.40	38.17	0.11	38.28	57.90	-19.62	QP
7	0.89	14.19	0.13	14.32	46.00	-31.68	Average
8	0.89	22.10	0.13	22.23	56.00	-33.77	QP
9	4.95	15.03	0.20	15.23	46.00	-30.77	Average
10	4.95	22.01	0.20	22.21	56.00	-33.79	QP
11	19.43	16.83	0.39	17.22	50.00	-32.78	Average
12	19.43	22.52	0.39	22.91	60.00	-37.09	QP

Notes:

1. Result = Read Value + Factor
2. Factor = LISN(ISN)Factor + Cable Loss
3. According to technical experiences, all spurious emission of 802.11MIMO mode at channel 3,6,9 are almost the same below 1GHz, so that the channel 3 was chosen as representative in final test.
4. The data is worse case.



Power	: AC 120V	Pol/Phase	: LINE
Test Mode	: 802.11a, CH149	Temperature	: 25 °C
Memo	:	Humidity	: 56 %

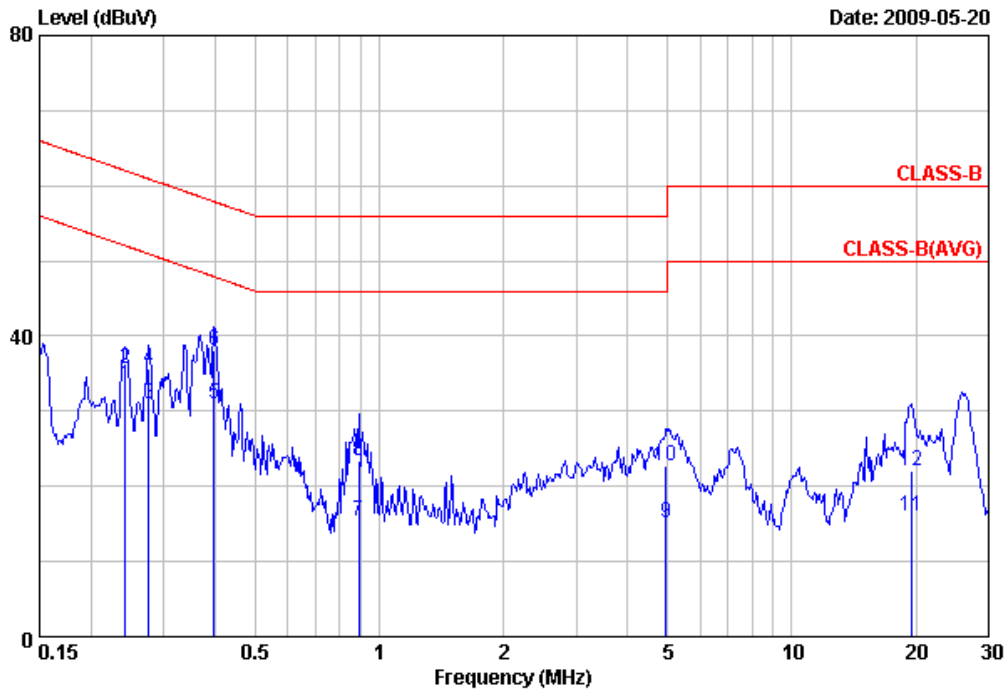

Item	Freq	Read Value	Factor	Result	Limit	Margin	Remark
	MHz	dBuV/m	dB	dBuV/m	dBuV/m	dB	
1	0.24	33.28	0.09	33.37	52.04	-18.67	Average
2	0.24	35.56	0.09	35.65	62.04	-26.39	QP
3	0.28	30.94	0.09	31.03	50.94	-19.91	Average
4	0.28	35.59	0.09	35.68	60.94	-25.26	QP
5	0.40	30.87	0.08	30.95	47.90	-16.95	Average
6	0.40	37.95	0.08	38.03	57.90	-19.87	QP
7	0.89	15.22	0.11	15.33	46.00	-30.67	Average
8	0.89	23.19	0.11	23.30	56.00	-32.70	QP
9	4.95	14.97	0.21	15.18	46.00	-30.82	Average
10	4.95	22.60	0.21	22.81	56.00	-33.19	QP
11	19.43	15.80	0.23	16.03	50.00	-33.97	Average
12	19.43	21.80	0.23	22.03	60.00	-37.97	QP

Notes:

1. Result = Read Value + Factor
2. Factor = LISN(ISN) Factor + Cable Loss
3. According to technical experiences, all spurious emission of 802.11a mode at channel 149,157,165 are almost the same below 1GHz, so that the channel 149 was chosen as representative in final test.
4. The data is worse case.



Power	: AC 120V	Pol/Phase	: NEUTRAL
Test Mode	: 802.11a, CH149	Temperature	: 25 °C
Memo	:	Humidity	: 56 %

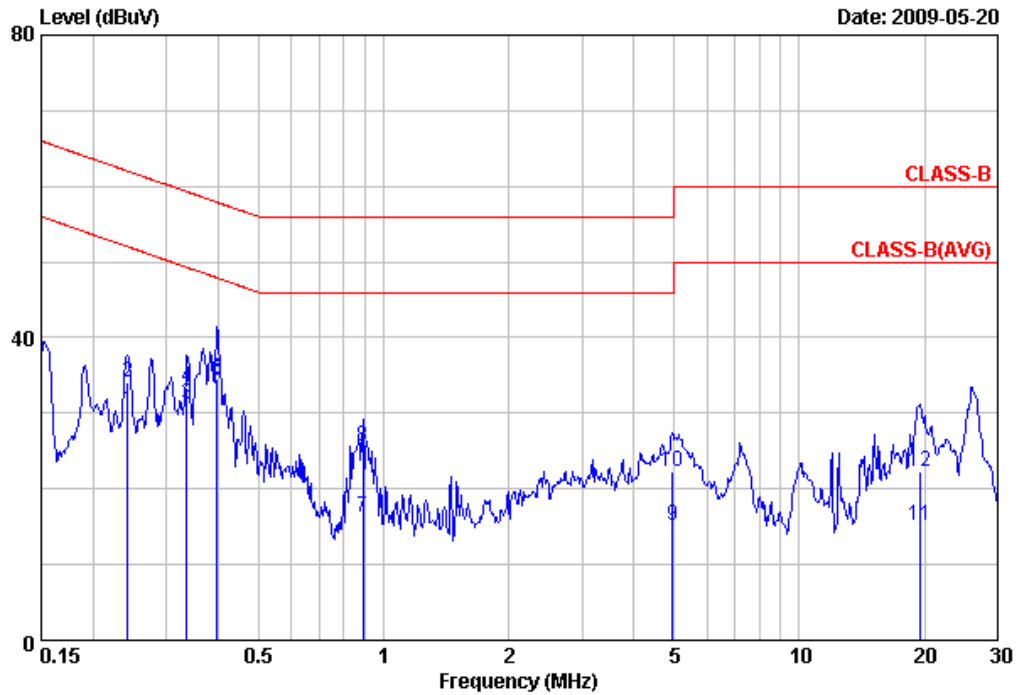

Item	Freq	Read Value	Factor	Result	Limit	Margin	Remark
	MHz	dBuV/m	dB	dBuV/m	dBuV/m	dB	
1	0.24	30.12	0.11	30.23	52.04	-21.81	Average
2	0.24	33.96	0.11	34.07	62.04	-27.97	QP
3	0.34	31.12	0.11	31.23	49.31	-18.08	Average
4	0.34	33.21	0.11	33.32	59.31	-25.99	QP
5	0.40	34.42	0.11	34.53	47.90	-13.37	Average
6	0.40	34.17	0.11	34.28	57.90	-23.62	QP
7	0.89	16.10	0.13	16.23	46.00	-29.77	Average
8	0.89	25.49	0.13	25.62	56.00	-30.38	QP
9	4.95	15.03	0.20	15.23	46.00	-30.77	Average
10	4.95	22.04	0.20	22.24	56.00	-33.76	QP
11	19.43	14.83	0.39	15.22	50.00	-34.78	Average
12	19.43	21.93	0.39	22.32	60.00	-37.68	QP

Notes:

1. Result = Read Value + Factor
2. Factor = LISN(ISN) Factor + Cable Loss
3. According to technical experiences, all spurious emission of 802.11a mode at channel 149,157,165 are almost the same below 1GHz, so that the channel 149 was chosen as representative in final test.
4. The data is worse case.



Power	: AC 120V	Pol/Phase	: LINE
Test Mode	: 802.11an HT20, CH149	Temperature	: 25 °C
Memo	:	Humidity	: 56 %

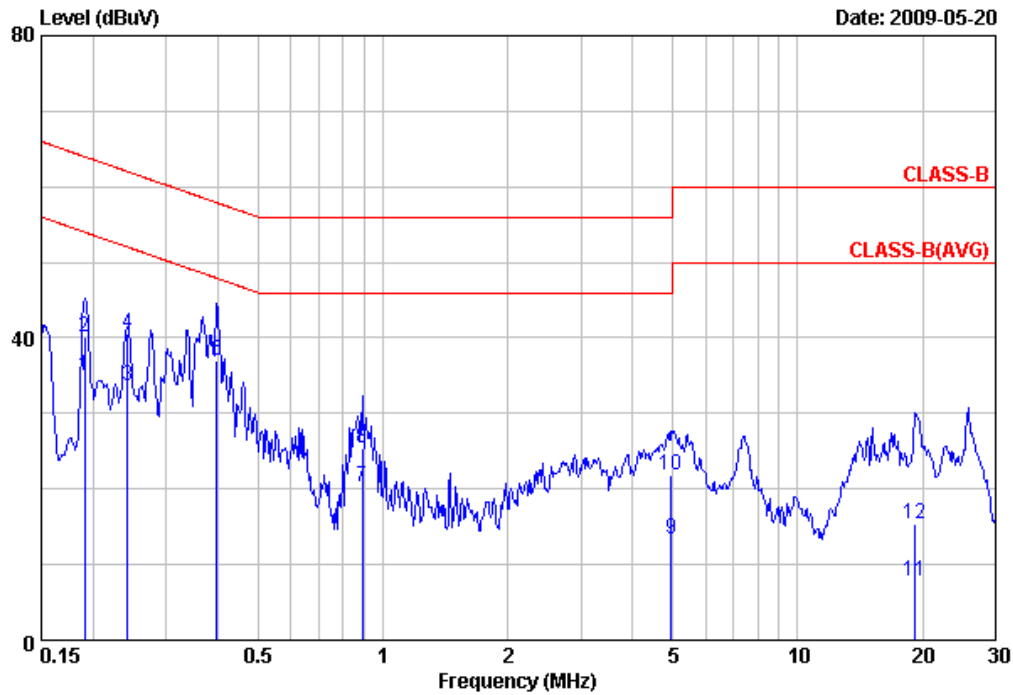

Item	Freq	Read Value	Factor	Result	Limit	Margin	Remark
	MHz	dBuV/m	dB	dBuV/m	dBuV/m	dB	
1	0.19	34.89	0.09	34.98	54.02	-19.04	Average
2	0.19	40.03	0.09	40.12	64.02	-23.90	QP
3	0.24	33.54	0.09	33.63	52.04	-18.41	Average
4	0.24	40.46	0.09	40.55	62.04	-21.49	QP
5	0.40	36.90	0.08	36.98	47.90	-10.92	Average
6	0.40	36.89	0.08	36.97	57.90	-20.93	QP
7	0.89	20.22	0.11	20.33	46.00	-25.67	Average
8	0.89	25.21	0.11	25.32	56.00	-30.68	QP
9	4.95	13.11	0.21	13.32	46.00	-32.68	Average
10	4.95	21.70	0.21	21.91	56.00	-34.09	QP
11	19.22	7.49	0.23	7.72	50.00	-42.28	Average
12	19.22	15.11	0.23	15.34	60.00	-44.66	QP

Notes:

1. Result = Read Value + Factor
2. Factor = LISN(ISN) Factor + Cable Loss
3. According to technical experiences, all spurious emission of 802.11an HT20 mode at channel 149,157,165 are almost the same below 1GHz,so that the channel 149 was chosen as representative in final test.
4. The data is worse case.



Power	: AC 120V	Pol/Phase	: NEUTRAL
Test Mode	: 802.11an HT20, CH149	Temperature	: 25 °C
Memo	:	Humidity	: 56 %

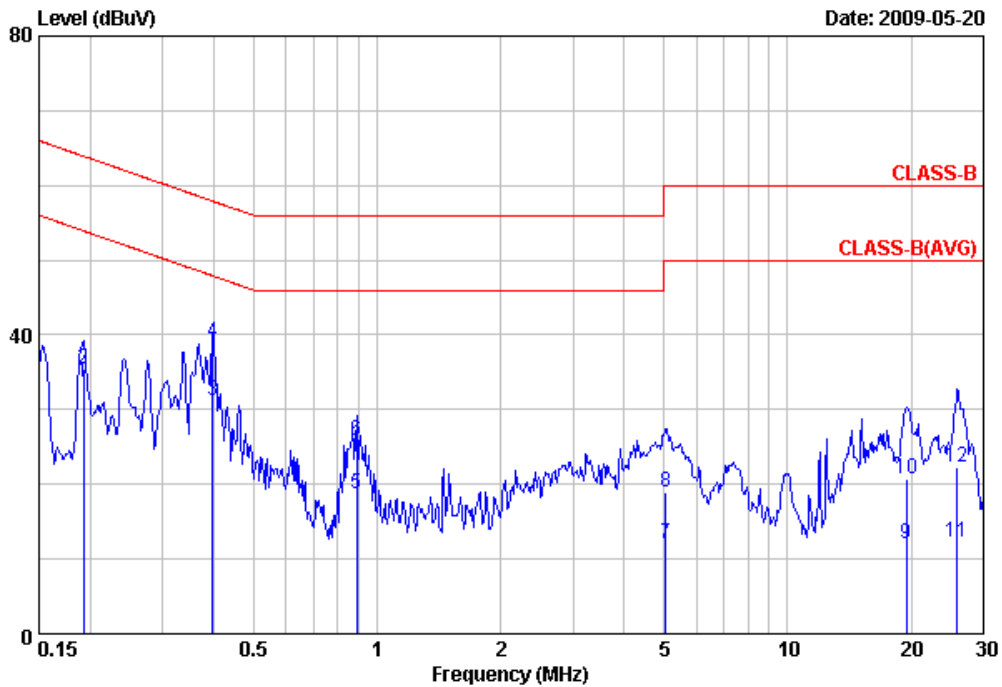

Item	Freq MHz	Read	Factor dB	Result dBuV/m	Limit dBuV/m	Margin dB	Remark
		Value dBuV/m					
1	0.19	33.43	0.12	33.55	53.93	-20.38	Average
2	0.19	35.30	0.12	35.42	63.93	-28.51	QP
3	0.40	31.04	0.11	31.15	47.90	-16.75	Average
4	0.40	38.96	0.11	39.07	57.90	-18.83	QP
5	0.89	18.49	0.13	18.62	46.00	-27.38	Average
6	0.89	25.82	0.13	25.95	56.00	-30.05	QP
7	5.06	11.87	0.20	12.07	50.00	-37.93	Average
8	5.06	18.71	0.20	18.91	60.00	-41.09	QP
9	19.43	11.71	0.39	12.10	50.00	-37.90	Average
10	19.43	20.23	0.39	20.62	60.00	-39.38	QP
11	25.86	11.96	0.36	12.32	50.00	-37.68	Average
12	25.86	22.00	0.36	22.36	60.00	-37.64	QP

Notes:

1. Result = Read Value + Factor
2. Factor = LISN(ISN) Factor + Cable Loss
3. According to technical experiences, all spurious emission of 802.11an HT20 mode at channel 149, 157, 165 are almost the same below 1GHz, so that the channel 149 was chosen as representative in final test.
4. The data is worse case.



Power	: AC 120V	Pol/Phase	: LINE
Test Mode	: 802.11an HT40, CH159	Temperature	: 25 °C
Memo	: EUT with PC	Humidity	: 56 %

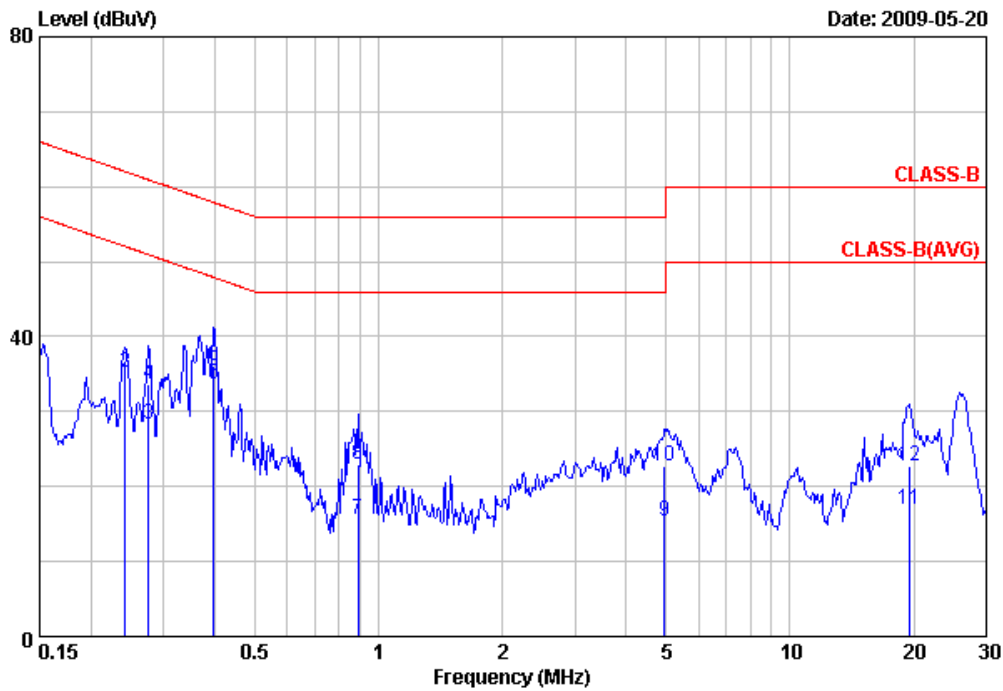

Item	Freq	Read Value	Factor	Result	Limit	Margin	Remark
	MHz	dBuV/m	dB	dBuV/m	dBuV/m	dB	
1	0.24	33.57	0.09	33.66	52.04	-18.38	Average
2	0.24	35.17	0.09	35.26	62.04	-26.78	QP
3	0.28	28.17	0.09	28.26	50.94	-22.68	Average
4	0.28	33.55	0.09	33.64	60.94	-27.30	QP
5	0.40	33.58	0.08	33.66	47.90	-14.24	Average
6	0.40	36.07	0.08	36.15	57.90	-21.75	QP
7	0.89	15.53	0.11	15.64	46.00	-30.36	Average
8	0.89	22.92	0.11	23.03	56.00	-32.97	QP
9	4.95	15.12	0.21	15.33	46.00	-30.67	Average
10	4.95	22.45	0.21	22.66	56.00	-33.34	QP
11	19.43	16.61	0.23	16.84	50.00	-33.16	Average
12	19.43	22.42	0.23	22.65	60.00	-37.35	QP

Notes:

1. Result = Read Value + Factor
2. Factor = LISN(ISN) Factor + Cable Loss
3. According to technical experiences, all spurious emission of 802.11an HT40 mode at channel 151,155,159 are almost the same below 1GHz, so that the channel 151 was chosen as representative in final test.
4. The data is worse case.



Power	: AC 120V	Pol/Phase	: NEUTRAL
Test Mode	: 802.11an HT40, CH159	Temperature	: 25 °C
Memo	:	Humidity	: 56 %

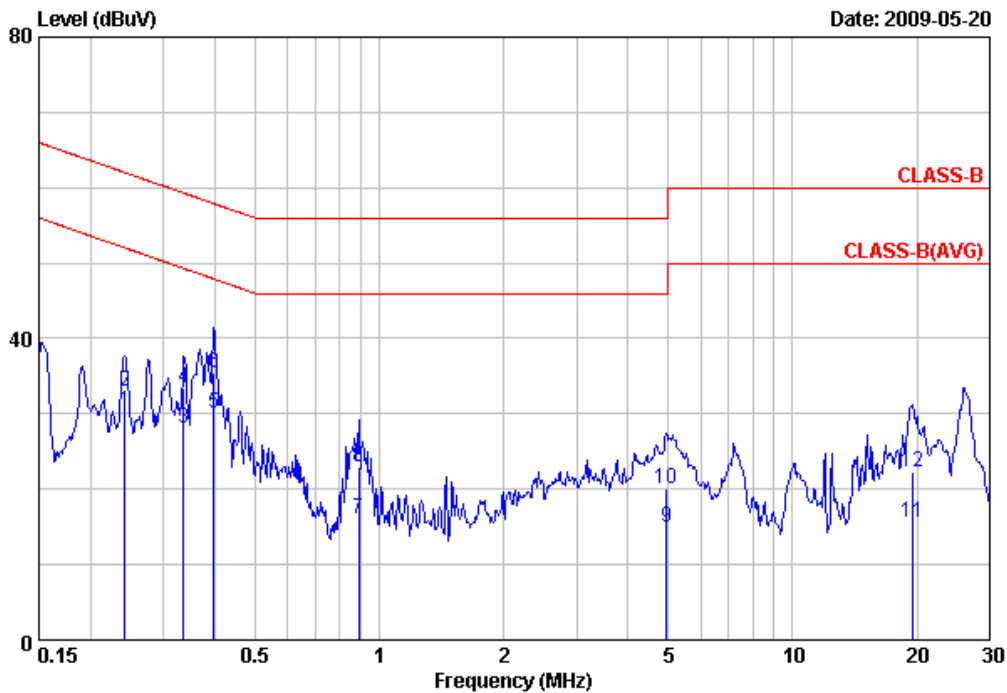

Item	Freq MHz	Read		Result dBuV/m	Limit dBuV/m	Margin dB	Remark
		Value dBuV/m	Factor dB				
1	0.24	30.22	0.11	30.33	52.04	-21.71	Average
2	0.24	32.92	0.11	33.03	62.04	-29.01	QP
3	0.34	27.95	0.11	28.06	49.31	-21.25	Average
4	0.34	33.22	0.11	33.33	59.31	-25.98	QP
5	0.40	29.95	0.11	30.06	47.90	-17.84	Average
6	0.40	35.22	0.11	35.33	57.90	-22.57	QP
7	0.89	15.90	0.13	16.03	46.00	-29.97	Average
8	0.89	22.90	0.13	23.03	56.00	-32.97	QP
9	4.95	14.83	0.20	15.03	46.00	-30.97	Average
10	4.95	19.83	0.20	20.03	56.00	-35.97	QP
11	19.43	15.23	0.39	15.62	50.00	-34.38	Average
12	19.43	21.94	0.39	22.33	60.00	-37.67	QP

Notes:

1. Result = Read Value + Factor
2. Factor = LISN(ISN) Factor + Cable Loss
3. According to technical experiences, all spurious emission of 802.11an HT40 mode at channel 151,155,159 are almost the same below 1GHz, so that the channel 151 was chosen as representative in final test.
4. The data is worse case.

Test engineer: Ben



5. Test of Radiated Emission

5.1 Test Limit

Radiated emissions from 30 MHz to 40 GHz were measured according to the methods defines in ANSI C63.4-2003. The EUT was placed, 0.8 meter above the ground plane, as shown in section 5.6.3. The interface cables and equipment positions were varied within limits of reasonable applications to determine the positions producing maximum radiated emissions for unintentional device, according to § 15.109(a), except for Class A digital devices, the field strength of radiated emissions from unintentional radiators at a distance of 3 meters shall not exceed the following values:

Frequency (MHz)	Distance Meters	Radiated (μ V / M)	Radiated (dB μ V/ M)
30-88	3	100	40.0
88-216	3	150	43.5
216-960	3	200	46.0
Above 960	3	500	54.0

For unintentional device, according to CISPR PUB.22, for Class B digital devices, the general requirement of field strength of radiated emissions from intentional radiators at a distance of 10 meters shall not exceed the below table.

Frequency (MHz)	Distance Meters	Radiated (dB μ V/ M)
30-230	10	30
230-1000	10	37

5.2 Test Procedures

- The EUT was placed on a rotatable table top 0.8 meter above ground.
- The EUT was set 3 meters from the interference receiving antenna which was mounted on the top of a variable height antenna tower.
- The table was rotated 360 degrees to determine the position of the highest radiation.
- The antenna is a broadband antenna and its height is varied between one meter and four meters above ground to find the maximum value of the field strength both horizontal polarization and vertical polarization of the antenna are set to make the measurement.
- For each suspected emission the EUT was arranged to its worst case and then tune the antenna tower (from 1 M to 4 M) and turn table (from 0 degree to 360 degrees) to find the maximum reading.
- Set the test-receiver system to Peak or CISPR quasi-peak Detect Function and specified bandwidth with Maximum Hold Mode.
- If the emission level of the EUT in peak mode was 3 dB lower than the limit specified, then testing will be stopped and peak values of EUT will be reported, otherwise, the emissions which do not have 3 dB margin will be repeated one by one using the quasi-peak method and reported.
- For testing above 1GHz, the emission level of the EUT in peak mode was 20dB lower than average limit (that means the emission level in peak mode also complies with the limit in average mode), then testing will be stopped and peak values of EUT will be reported, otherwise, the emissions will be measured in average mode again and reported.



5.3 Typical Test Setup

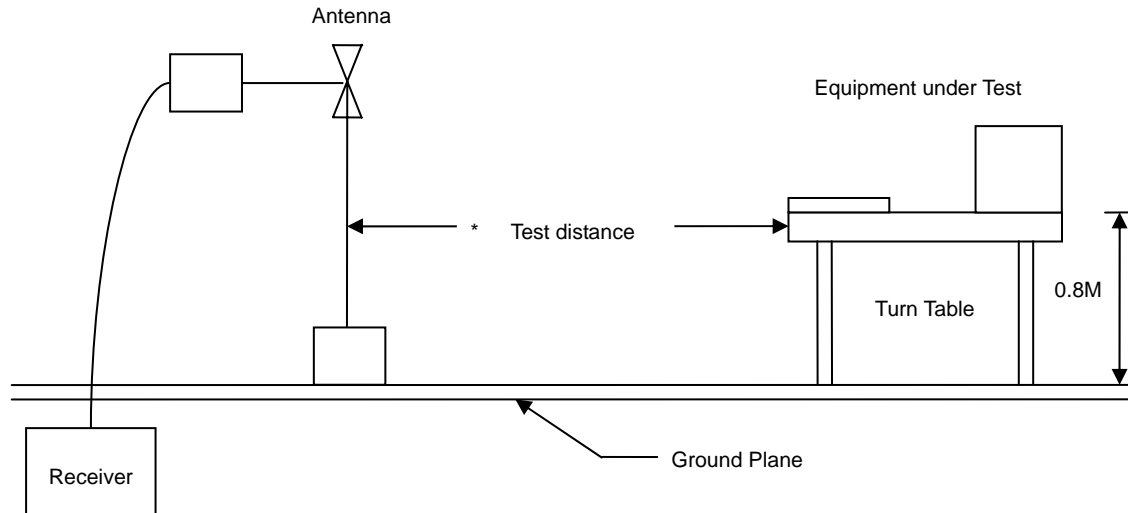

5.4 Measurement Equipment

Instrument/Ancillary	Model No.	Manufacturer	Serial No.	Calibration Date	Valid Date
Bilog Antenna	CBL6112B	Schaffner	2840	2009/05/14	2010/05/13
Signal Generator	8648B	HP	3629U00612	2008/10/08	2009/10/07
Amplifier	8447D	Agilent	2944A10593	2009/05/21	2010/05/20
EMI Receiver	8546A	HP	3807A00454	2008/08/07	2009/08/06
Spectrum	FSP40	R&S	100047	2009/02/21	2010/02/20
Horn Antenna	3115	EMCO	31589	2009/05/04	2010/05/03
Preamplifier	Agilent	8449B	3008A01954	2009/02/27	2010/02/26



5.5 Test Result and Data

Power	: AC 120V	Pol/Phase	: VERTICAL
Test Mode	: 802.11g, CH1	Temperature	: 26 °C
Memo	:	Humidity	: 58 %

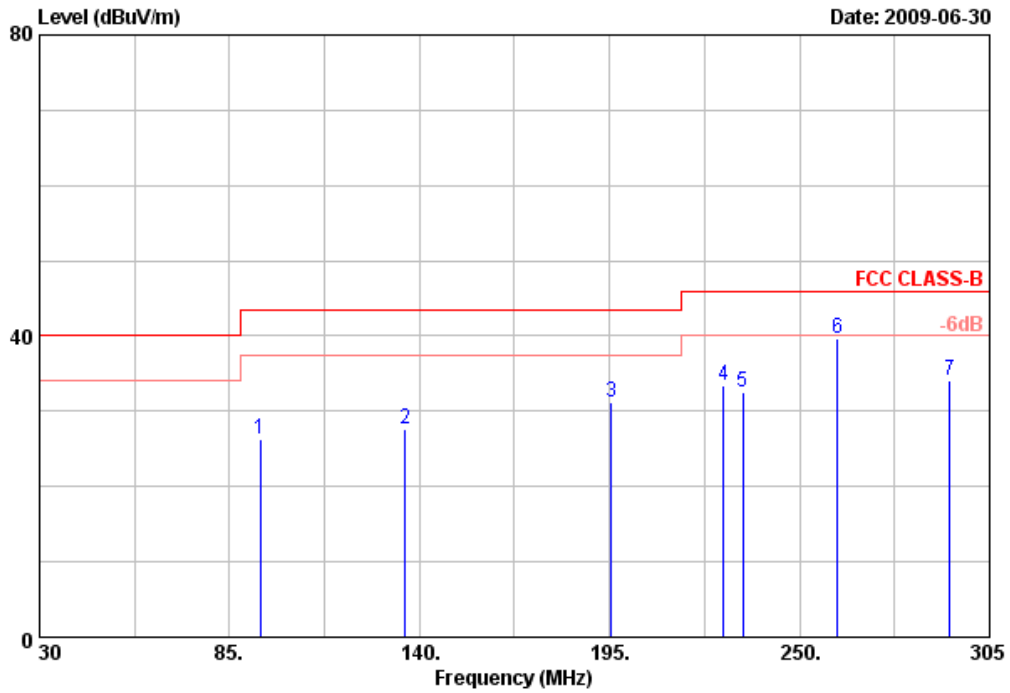

Item	Freq	Read Value	Factor	Result	Limit	Margin	Remark	Ant Pos	Tab Pos
	MHz	dBUV/m	dB	dBUV/m	dBUV/m	dB		cm	Deg
1	93.80	38.48	-12.29	26.19	43.50	-17.31	Peak	104	0
2	135.88	37.79	-10.14	27.65	43.50	-15.85	Peak	104	0
3	195.55	41.42	-10.26	31.16	43.50	-12.34	Peak	104	0
4	228.00	44.42	-11.02	33.40	46.00	-12.60	Peak	104	0
5	233.50	44.15	-11.69	32.46	46.00	-13.54	Peak	104	0
6	261.00	51.79	-12.03	39.76	46.00	-6.24	Peak	104	0
7	293.45	46.40	-12.35	34.05	46.00	-11.95	Peak	104	0

Notes:

1. Result = Read Value + Factor
2. Factor = Antenna Factor + Cable Loss - Amplifier
3. The resolution bandwidth of test receiver/spectrum analyzer is 120KHz and video bandwidth is 300kHz for Peak detection and Quasi-peak detection at frequency below 1GHz.
4. All emission below 1GHz at 802.11b/g mode are all the same,so the 802.11g mode chosen as representative in final test.
5. According to technical experiences,all spurious emission of 802.11g mode at channel 1,6,11 are almost the same below 1GHz,so that the channel 1 was chosen as representative in final test.
6. The data is worse case.



Power	: AC 120V	Pol/Phase	: VERTICAL
Test Mode	: 802.11g, CH1	Temperature	: 26 °C
Memo	:	Humidity	: 58 %

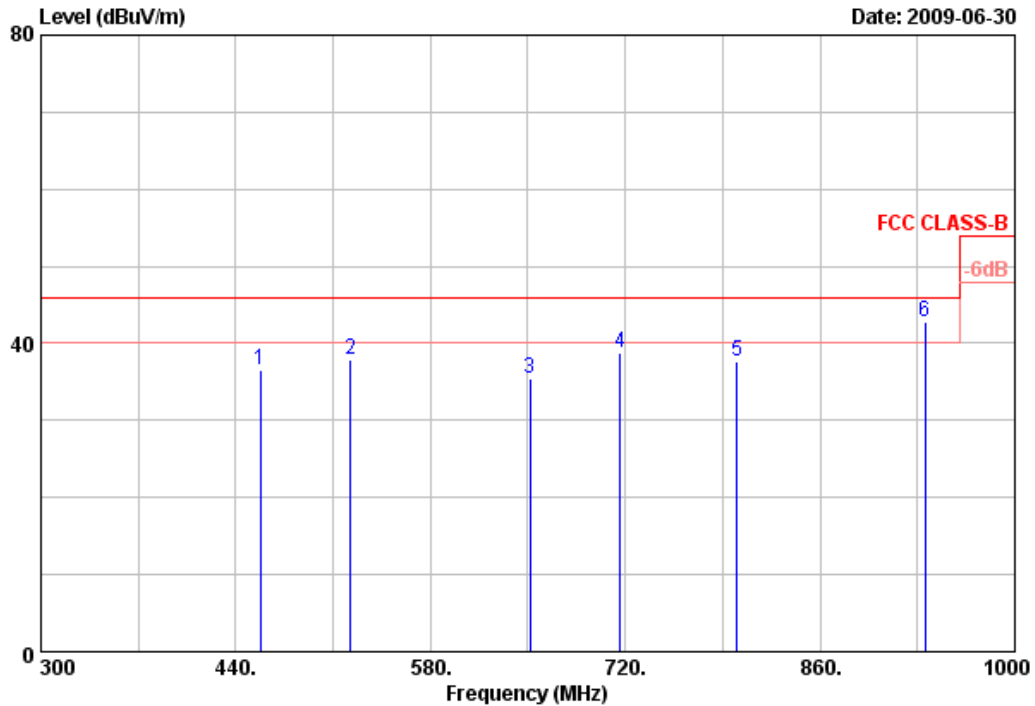

Item	Freq	Read Value	Factor	Result	Limit	Margin	Remark	Ant Pos	Tab Pos
	MHz	dBuV/m	dB	dBuV/m	dBuV/m	dB		cm	Deg
1	457.50	44.64	-8.05	36.59	46.00	-9.41	Peak	104	0
2	522.60	46.20	-8.33	37.87	46.00	-8.13	Peak	104	0
3	651.40	40.79	-5.31	35.48	46.00	-10.52	Peak	104	0
4	716.50	41.28	-2.59	38.69	46.00	-7.31	Peak	104	0
5	800.50	38.80	-1.09	37.71	46.00	-8.29	Peak	104	0
6	935.60	38.57	4.12	42.69	46.00	-3.31	QP	104	0

Notes:

1. Result = Read Value + Factor
2. Factor = Antenna Factor + Cable Loss - Amplifier
3. The resolution bandwidth of test receiver/spectrum analyzer is 120KHz and video bandwidth is 300KHz for Peak detection and Quasi-peak detection at frequency below 1GHz.
4. All emission below 1GHz at 802.11b/g mode are all the same,so the 802.11g mode chosen as representative in final test.
5. According to technical experiences,all spurious emission of 802.11g mode at channel 1,6,11 are almost the same below 1GHz,so that the channel 1 was chosen as representative in final test.
6. The data is worse case.



Power	: AC 120V	Pol/Phase	: HORIZONTAL
Test Mode	: 802.11g, CH1	Temperature	: 26 °C
Memo	:	Humidity	: 58 %

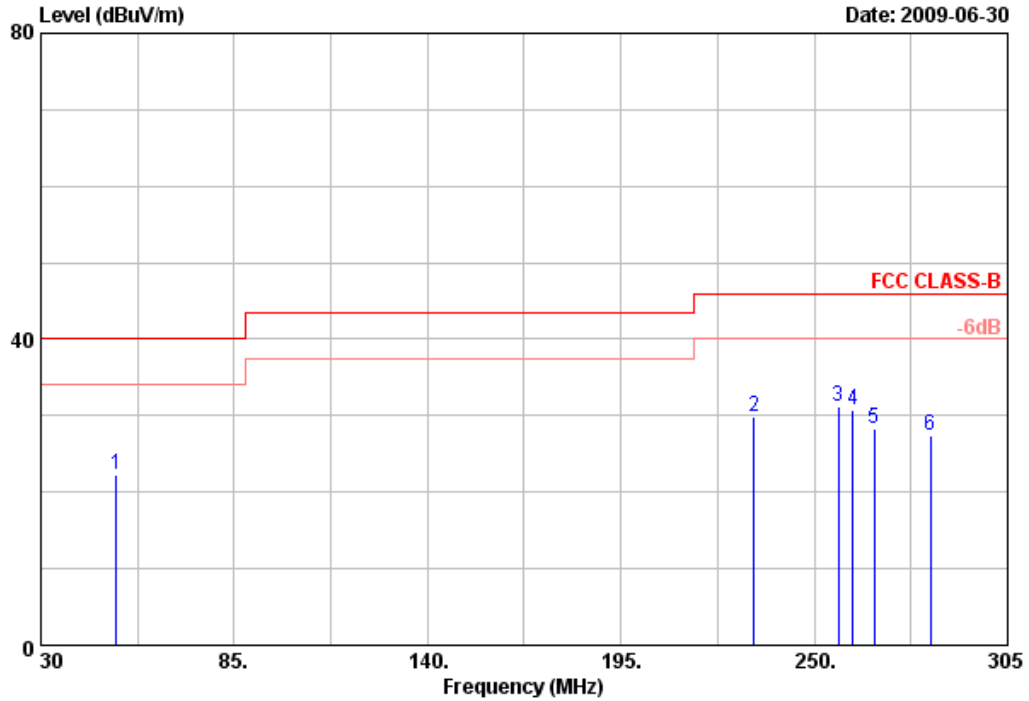

Item	Freq	Read Value	Factor	Result	Limit	Margin	Remark	Ant Pos	Tab Pos
	MHz	dBuV/m	dB	dBuV/m	dBuV/m	dB		cm	Deg
1	51.45	37.25	-15.00	22.25	40.00	-17.75	Peak	104	360
2	232.95	45.99	-16.11	29.88	46.00	-16.12	Peak	104	360
3	256.88	45.36	-14.12	31.24	46.00	-14.76	Peak	104	360
4	261.00	44.65	-13.86	30.79	46.00	-15.21	Peak	104	360
5	267.05	41.94	-13.53	28.41	46.00	-17.59	Peak	104	360
6	283.00	40.72	-13.26	27.46	46.00	-18.54	Peak	104	360

Notes:

1. Result = Read Value + Factor
2. Factor = Antenna Factor + Cable Loss - Amplifier
3. The resolution bandwidth of test receiver/spectrum analyzer is 120KHz and video bandwidth is 300kHz for Peak detection and Quasi-peak detection at frequency below 1GHz.
4. All emission below 1GHz at 802.11b/g mode are all the same, so the 802.11g mode chosen as representative in final test.
5. According to technical experiences, all spurious emission of 802.11g mode at channel 1, 6, 11 are almost the same below 1GHz, so that the channel 1 was chosen as representative in final test.
6. The data is worse case.



Power	: AC 120V	Pol/Phase	: HORIZONTAL
Test Mode	: 802.11g, CH1	Temperature	: 26 °C
Memo	:	Humidity	: 58 %

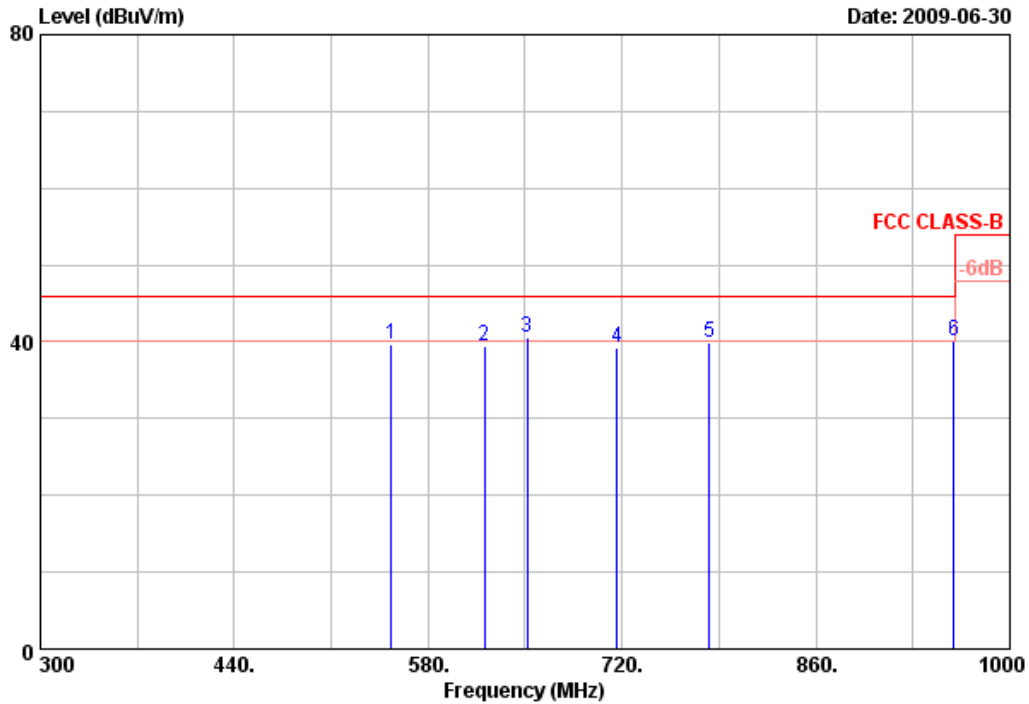

Item	Freq	Read Value	Factor	Result	Limit	Margin	Remark	Ant Pos	Tab Pos
	MHz	dBuV/m	dB	dBuV/m	dBuV/m	dB		cm	Deg
1	553.40	42.15	-2.56	39.59	46.00	-6.41	Peak	104	360
2	620.60	40.94	-1.42	39.52	46.00	-6.48	Peak	104	360
3	651.40	42.90	-2.36	40.54	46.00	-5.46	QP	104	360
4	716.50	42.46	-3.18	39.28	46.00	-6.72	Peak	104	360
5	783.00	40.11	-0.22	39.89	46.00	-6.11	Peak	104	360
6	959.40	38.83	1.28	40.11	46.00	-5.89	QP	104	360

Notes:

1. Result = Read Value + Factor
2. Factor = Antenna Factor + Cable Loss - Amplifier
3. The resolution bandwidth of test receiver/spectrum analyzer is 120KHz and video bandwidth is 300KHz for Peak detection and Quasi-peak detection at frequency below 1GHz.
4. All emission below 1GHz at 802.11b/g mode are all the same,so the 802.11g mode chosen as representative in final test.
5. According to technical experiences,all spurious emission of 802.11g mode at channel 1,6,11 are almost the same below 1GHz,so that the channel 1 was chosen as representative in final test.
6. The data is worse case.



Power	: AC 120V	Pol/Phase	: VERTICAL
Test Mode	: 802.11b, CH1	Temperature	: 26 °C
Memo	:	Humidity	: 58 %

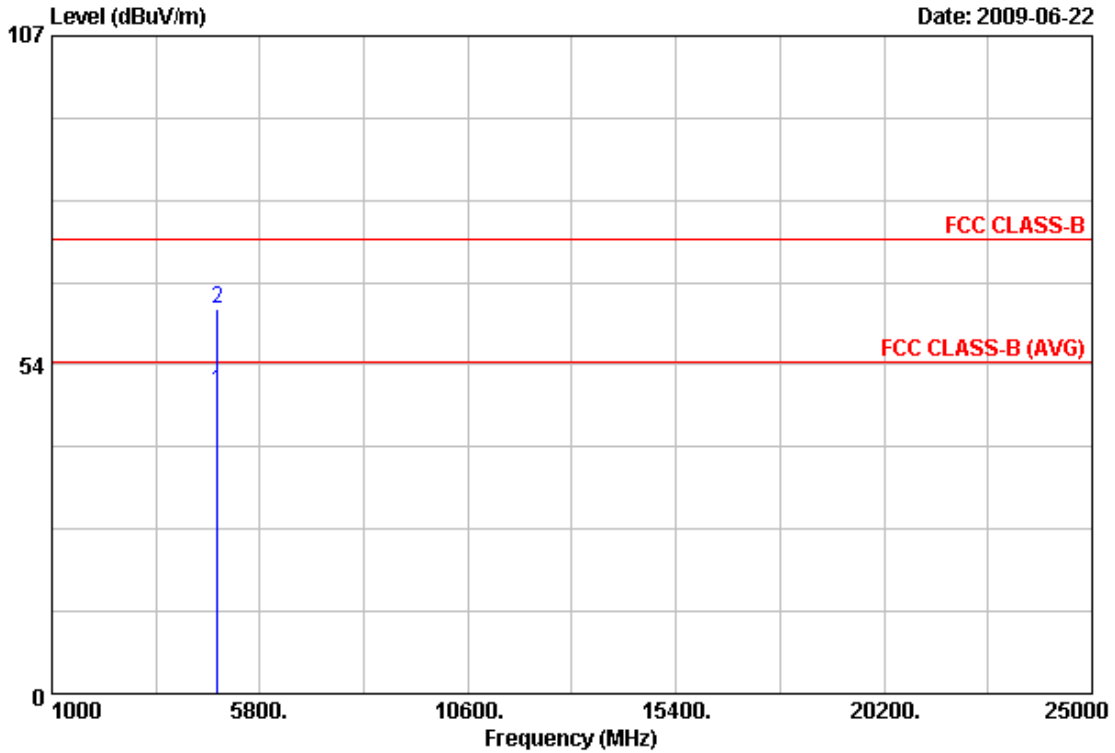

Item	Freq	Read		Factor	Result	Limit	Margin	Remark	Ant Pos	Tab Pos
		MHz	dBuV/m							
1	4822.10	41.44	7.69	49.13	54.00	-4.87	Average	102	0	
2	4824.10	54.86	7.69	62.55	74.00	-11.45	Peak	102	0	

Notes:

1. Result = Read Value + Factor
2. Factor = Antenna Factor + Cable Loss - Amplifier
3. The resolution bandwidth of test receiver/spectrum analyzer is 120KHz and video bandwidth is 300kHz for Peak detection and Quasi-peak detection at frequency below 1GHz.
4. The resolution bandwidth of test receiver/spectrum analyzer is 1MHz and video bandwidth is 3MHz for Peak detection at frequency above 1GHz.
5. The resolution bandwidth of test receiver/spectrum analyzer is 1MHz and video bandwidth is 10Hz for Average detection at frequency above 1GHz.
6. The other emissions is too low to be measured.



Power	: AC 120V	Pol/Phase	: HORIZONTAL
Test Mode	: 802.11b, CH1	Temperature	: 26 °C
Memo	:	Humidity	: 58 %

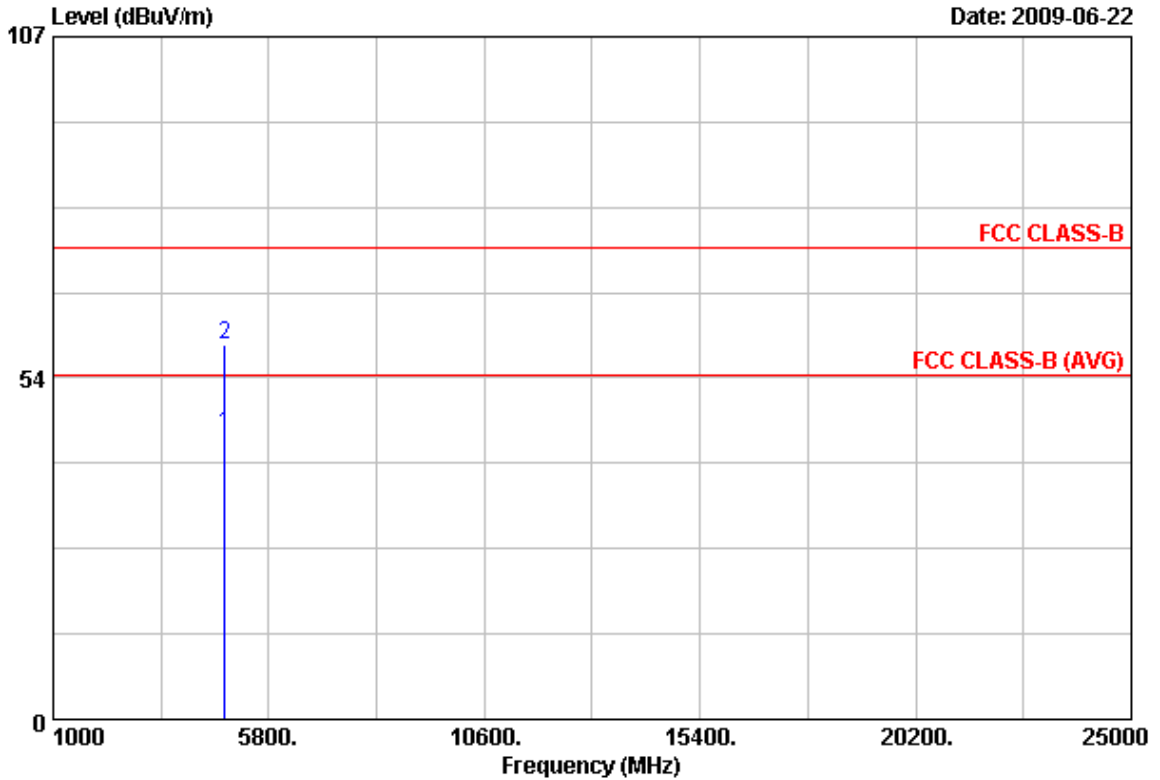

Item	Freq	Read Value	Factor	Result	Limit	Margin	Remark	Ant Pos	Tab Pos
	MHz	dBuV/m	dB	dBuV/m	dBuV/m	dB		cm	Deg
1	4822.10	37.16	7.69	44.85	54.00	-9.15	Average	102	0
2	4823.85	50.91	7.69	58.60	74.00	-15.40	Peak	102	0

Notes:

1. Result = Read Value + Factor
2. Factor = Antenna Factor + Cable Loss - Amplifier
3. The resolution bandwidth of test receiver/spectrum analyzer is 120KHz and video bandwidth is 300KHz for Peak detection and Quasi-peak detection at frequency below 1GHz.
4. The resolution bandwidth of test receiver/spectrum analyzer is 1MHz and video bandwidth is 3MHz for Peak detection at frequency above 1GHz.
5. The resolution bandwidth of test receiver/spectrum analyzer is 1MHz and video bandwidth is 10Hz for Average detection at frequency above 1GHz.
6. The other emissions is too low to be measured.



Power	: AC 120V	Pol/Phase	: VERTICAL
Test Mode	: 802.11b, CH6	Temperature	: 26 °C
Memo	:	Humidity	: 58 %

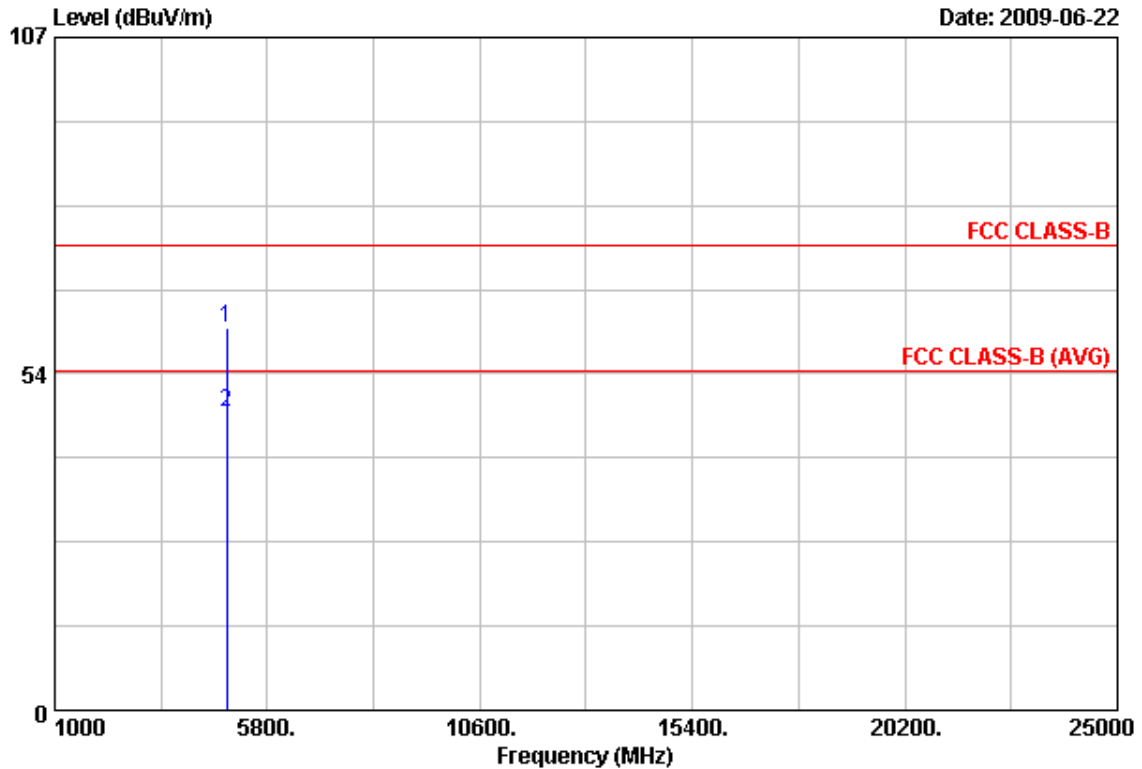

Item	Freq	Read Value	Factor	Result	Limit	Margin	Remark	Ant Pos	Tab Pos
	MHz	dBuV/m	dB	dBuV/m	dBuV/m	dB		cm	Deg
1	4874.30	52.88	7.86	60.74	74.00	-13.26	Peak	102	0
2	4875.65	39.36	7.89	47.25	54.00	-6.75	Average	102	0

Notes:

1. Result = Read Value + Factor
2. Factor = Antenna Factor + Cable Loss - Amplifier
3. The resolution bandwidth of test receiver/spectrum analyzer is 120KHz and video bandwidth is 300kHz for Peak detection and Quasi-peak detection at frequency below 1GHz.
4. The resolution bandwidth of test receiver/spectrum analyzer is 1MHz and video bandwidth is 3MHz for Peak detection at frequency above 1GHz.
5. The resolution bandwidth of test receiver/spectrum analyzer is 1MHz and video bandwidth is 10Hz for Average detection at frequency above 1GHz.
6. The other emissions is too low to be measured.



Power	: AC 120V	Pol/Phase	: HORIZONTAL
Test Mode	: 802.11b, CH6	Temperature	: 26 °C
Memo	:	Humidity	: 58 %

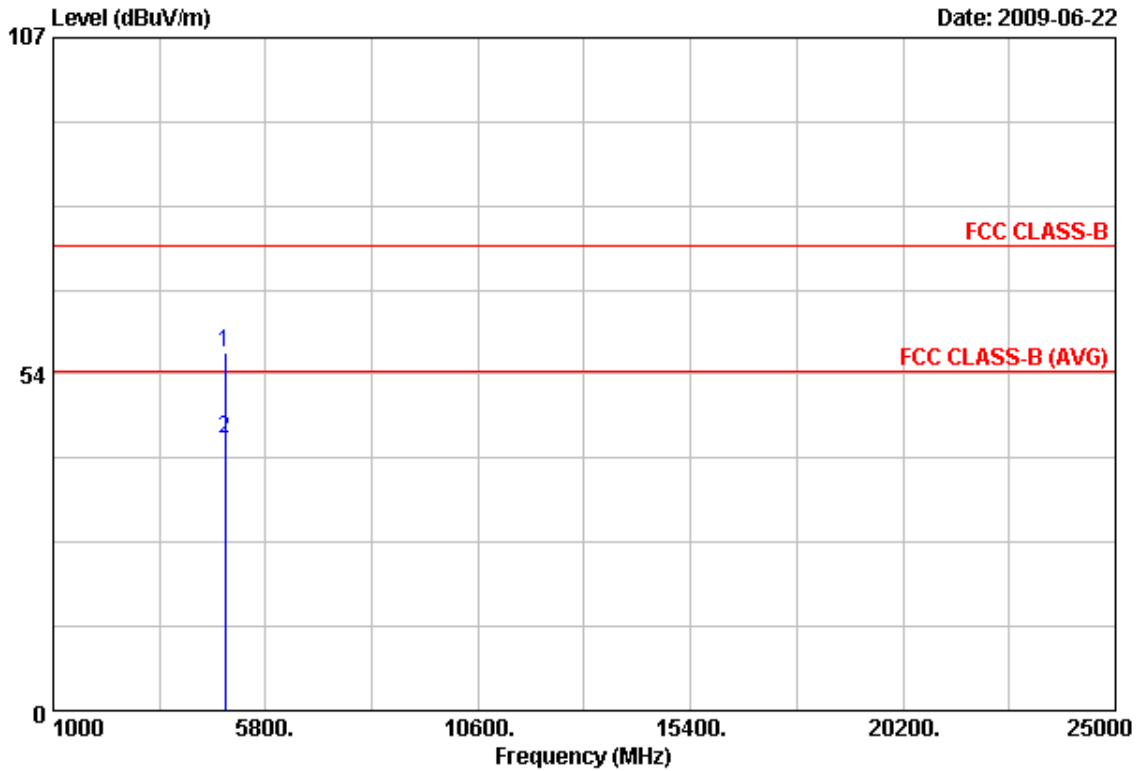

Item	Freq	Read Value	Factor	Result	Limit	Margin	Remark	Ant Pos	Tab Pos
	MHz	dBuV/m	dB	dBuV/m	dBuV/m	dB		cm	Deg
1	4874.40	49.15	7.86	57.01	74.00	-16.99	Peak	102	0
2	4875.65	35.22	7.89	43.11	54.00	-10.89	Average	102	0

Notes:

1. Result = Read Value + Factor
2. Factor = Antenna Factor + Cable Loss - Amplifier
3. The resolution bandwidth of test receiver/spectrum analyzer is 120KHz and video bandwidth is 300kHz for Peak detection and Quasi-peak detection at frequency below 1GHz.
4. The resolution bandwidth of test receiver/spectrum analyzer is 1MHz and video bandwidth is 3MHz for Peak detection at frequency above 1GHz.
5. The resolution bandwidth of test receiver/spectrum analyzer is 1MHz and video bandwidth is 10Hz for Average detection at frequency above 1GHz.
6. The other emissions is too low to be measured.



Power	: AC 120V	Pol/Phase	: VERTICAL
Test Mode	: 802.11b, CH11	Temperature	: 26 °C
Memo	:	Humidity	: 58 %

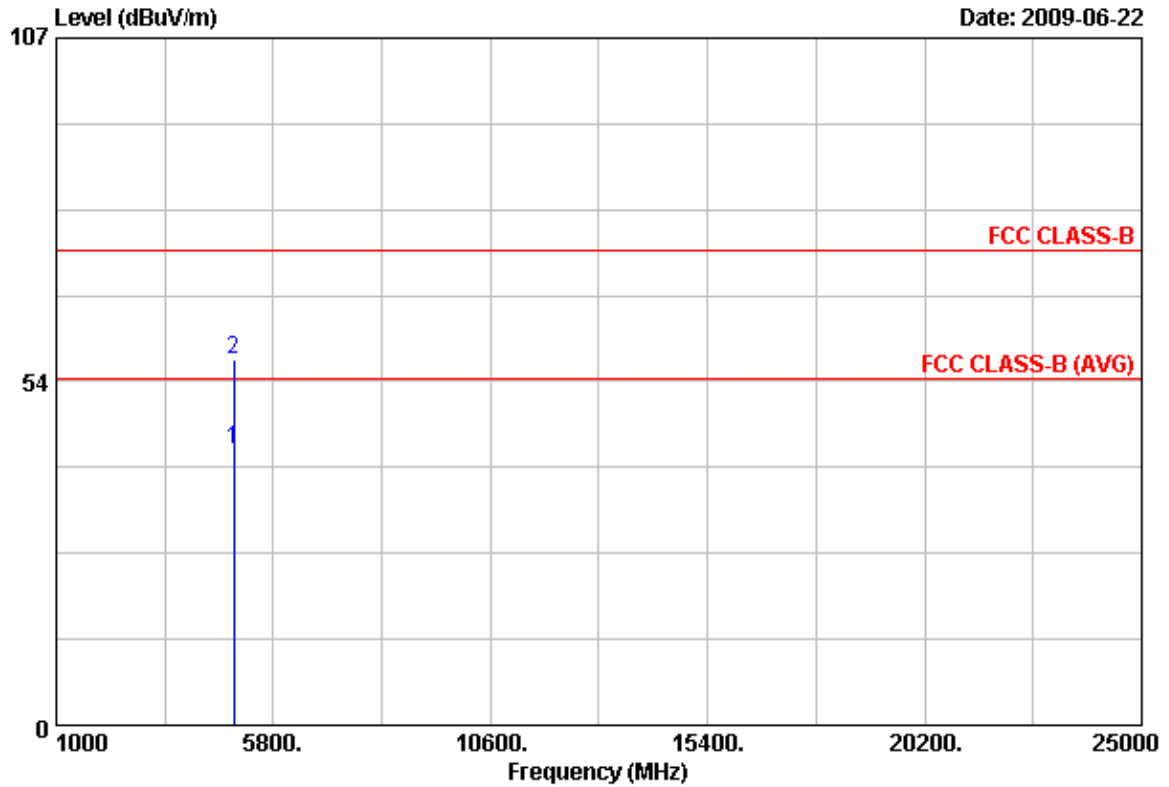

Item	Freq	Read Value	Factor	Result	Limit	Margin	Remark	Ant Pos	Tab Pos
	MHz	dBuV/m	dB	dBuV/m	dBuV/m	dB		cm	Deg
1	4922.20	35.00	8.03	43.03	54.00	-10.97	Average	102	0
2	4924.85	48.99	8.03	57.02	74.00	-16.98	Peak	102	0

Notes:

1. Result = Read Value + Factor
2. Factor = Antenna Factor + Cable Loss - Amplifier
3. The resolution bandwidth of test receiver/spectrum analyzer is 120KHz and video bandwidth is 300kHz for Peak detection and Quasi-peak detection at frequency below 1GHz.
4. The resolution bandwidth of test receiver/spectrum analyzer is 1MHz and video bandwidth is 3MHz for Peak detection at frequency above 1GHz.
5. The resolution bandwidth of test receiver/spectrum analyzer is 1MHz and video bandwidth is 10Hz for Average detection at frequency above 1GHz.
6. The other emissions is too low to be measured.



Power	: AC 120V	Pol/Phase	: HORIZONTAL
Test Mode	: 802.11b, CH11	Temperature	: 26 °C
Memo	:	Humidity	: 58 %

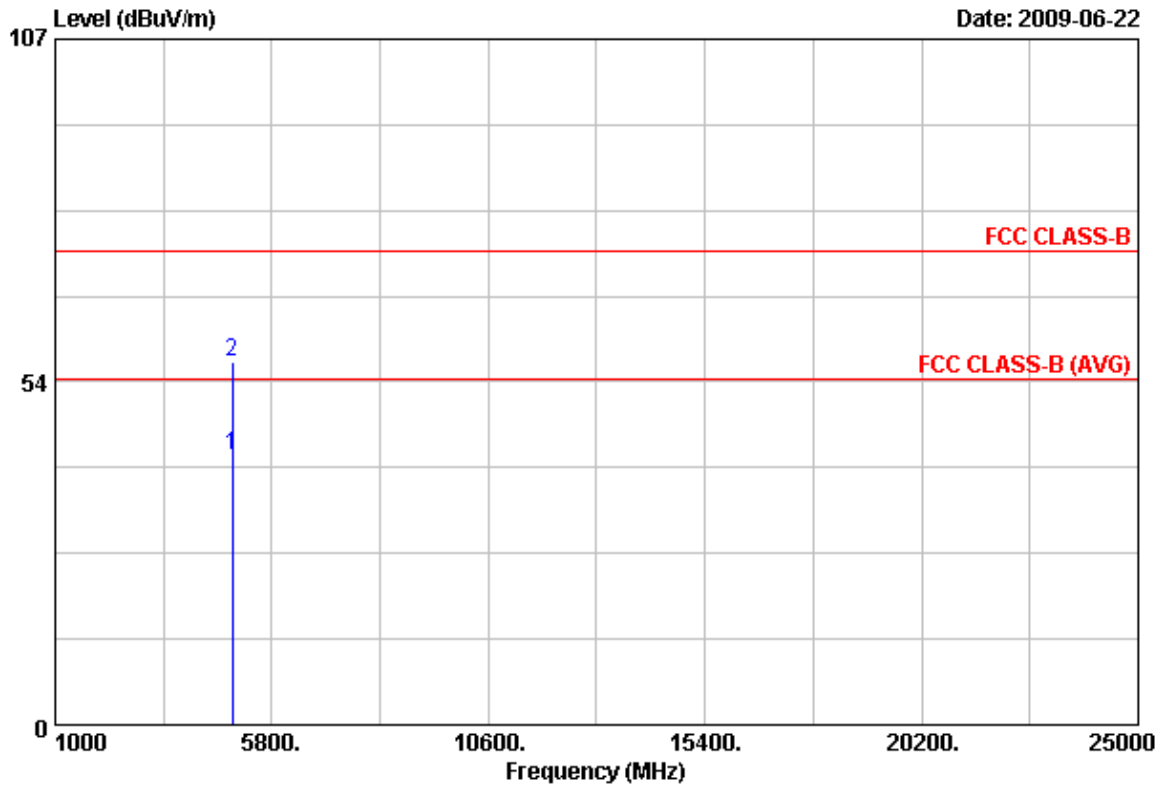

Item	Freq	Read Value	Factor	Result	Limit	Margin	Remark	Ant Pos	Tab Pos
	MHz	dBuV/m	dB	dBuV/m	dBuV/m	dB		cm	Deg
1	4922.00	33.97	8.03	42.00	54.00	-12.00	Average	102	0
2	4924.75	48.64	8.03	56.67	74.00	-17.33	Peak	102	0

Notes:

1. Result = Read Value + Factor
2. Factor = Antenna Factor + Cable Loss - Amplifier
3. The resolution bandwidth of test receiver/spectrum analyzer is 120KHz and video bandwidth is 300KHz for Peak detection and Quasi-peak detection at frequency below 1GHz.
4. The resolution bandwidth of test receiver/spectrum analyzer is 1MHz and video bandwidth is 3MHz for Peak detection at frequency above 1GHz.
5. The resolution bandwidth of test receiver/spectrum analyzer is 1MHz and video bandwidth is 10Hz for Average detection at frequency above 1GHz.
6. The other emissions is too low to be measured.



Power	: AC 120V	Pol/Phase	: VERTICAL
Test Mode	: 802.11g, CH1	Temperature	: 26 °C
Memo	:	Humidity	: 58 %

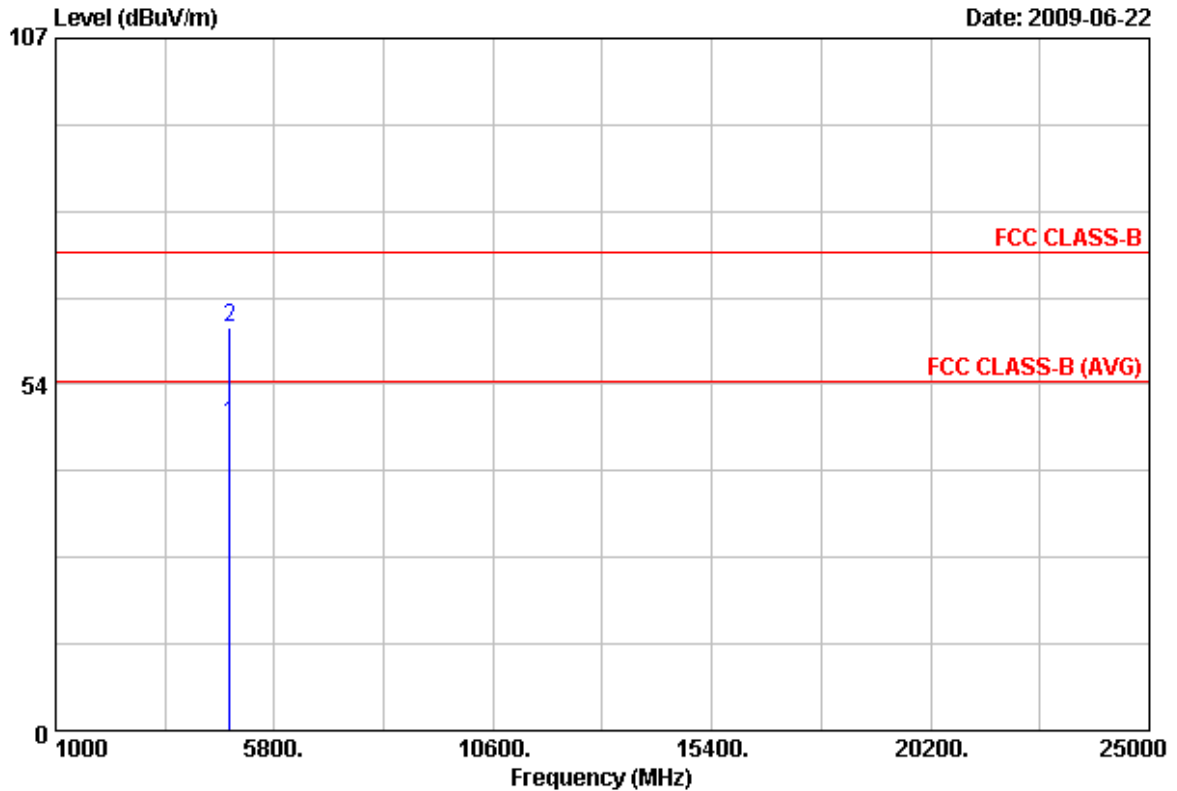

Item	Freq	Read Value	Factor	Result	Limit	Margin	Remark	Ant Pos	Tab Pos
	MHz	dBuV/m	dB	dBuV/m	dBuV/m	dB		cm	Deg
1	4824.20	39.82	7.69	47.51	54.00	-6.49	Average	102	0
2	4827.90	54.47	7.72	62.19	74.00	-11.81	Peak	102	0

Notes:

1. Result = Read Value + Factor
2. Factor = Antenna Factor + Cable Loss - Amplifier
3. The resolution bandwidth of test receiver/spectrum analyzer is 120KHz and video bandwidth is 300kHz for Peak detection and Quasi-peak detection at frequency below 1GHz.
4. The resolution bandwidth of test receiver/spectrum analyzer is 1MHz and video bandwidth is 3MHz for Peak detection at frequency above 1GHz.
5. The resolution bandwidth of test receiver/spectrum analyzer is 1MHz and video bandwidth is 10Hz for Average detection at frequency above 1GHz.
6. The other emissions is too low to be measured.



Power	: AC 120V	Pol/Phase	: HORIZONTAL
Test Mode	: 802.11g, CH1	Temperature	: 26 °C
Memo	:	Humidity	: 58 %

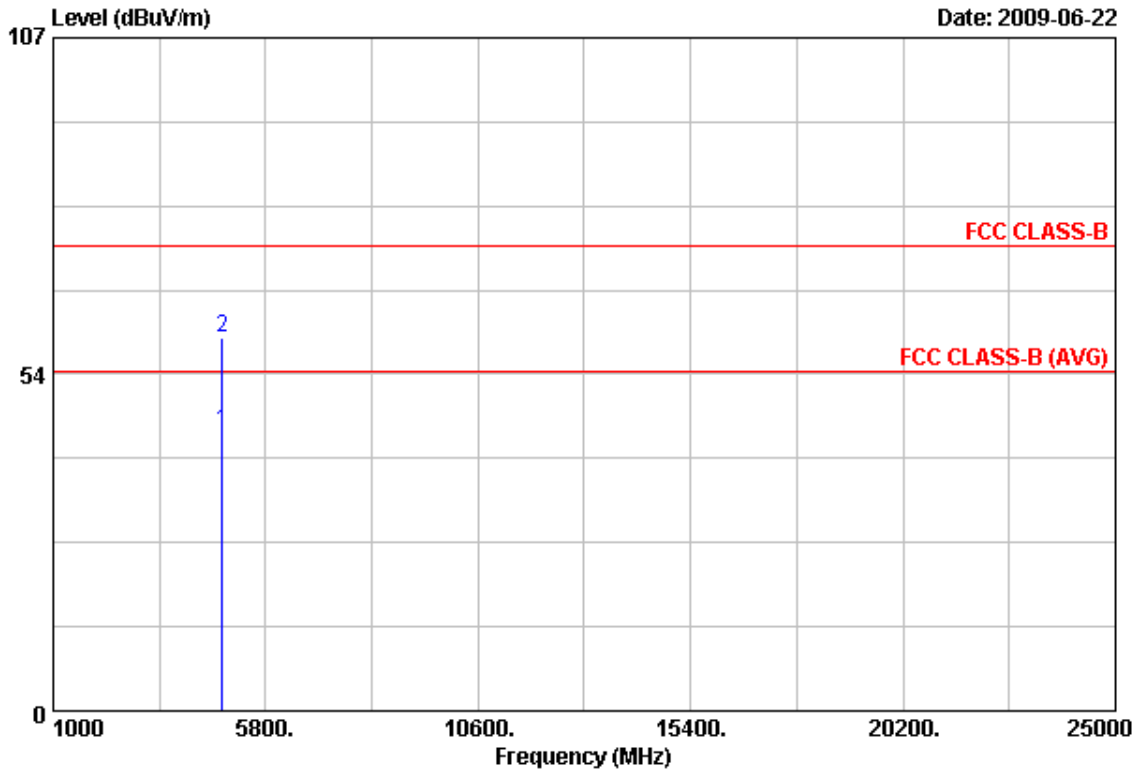

Item	Freq	Read Value	Factor	Result	Limit	Margin	Remark	Ant Pos	Tab Pos
	MHz	dBuV/m	dB	dBuV/m	dBuV/m	dB		cm	Deg
1	4824.20	36.72	7.69	44.41	54.00	-9.59	Average	102	0
2	4824.95	51.52	7.69	59.21	74.00	-14.79	Peak	102	0

Notes:

1. Result = Read Value + Factor
2. Factor = Antenna Factor + Cable Loss - Amplifier
3. The resolution bandwidth of test receiver/spectrum analyzer is 120KHz and video bandwidth is 300kHz for Peak detection and Quasi-peak detection at frequency below 1GHz.
4. The resolution bandwidth of test receiver/spectrum analyzer is 1MHz and video bandwidth is 3MHz for Peak detection at frequency above 1GHz.
5. The resolution bandwidth of test receiver/spectrum analyzer is 1MHz and video bandwidth is 10Hz for Average detection at frequency above 1GHz.
6. The other emissions is too low to be measured.



Power	: AC 120V	Pol/Phase	: VERTICAL
Test Mode	: 802.11g, CH6	Temperature	: 26 °C
Memo	:	Humidity	: 58 %

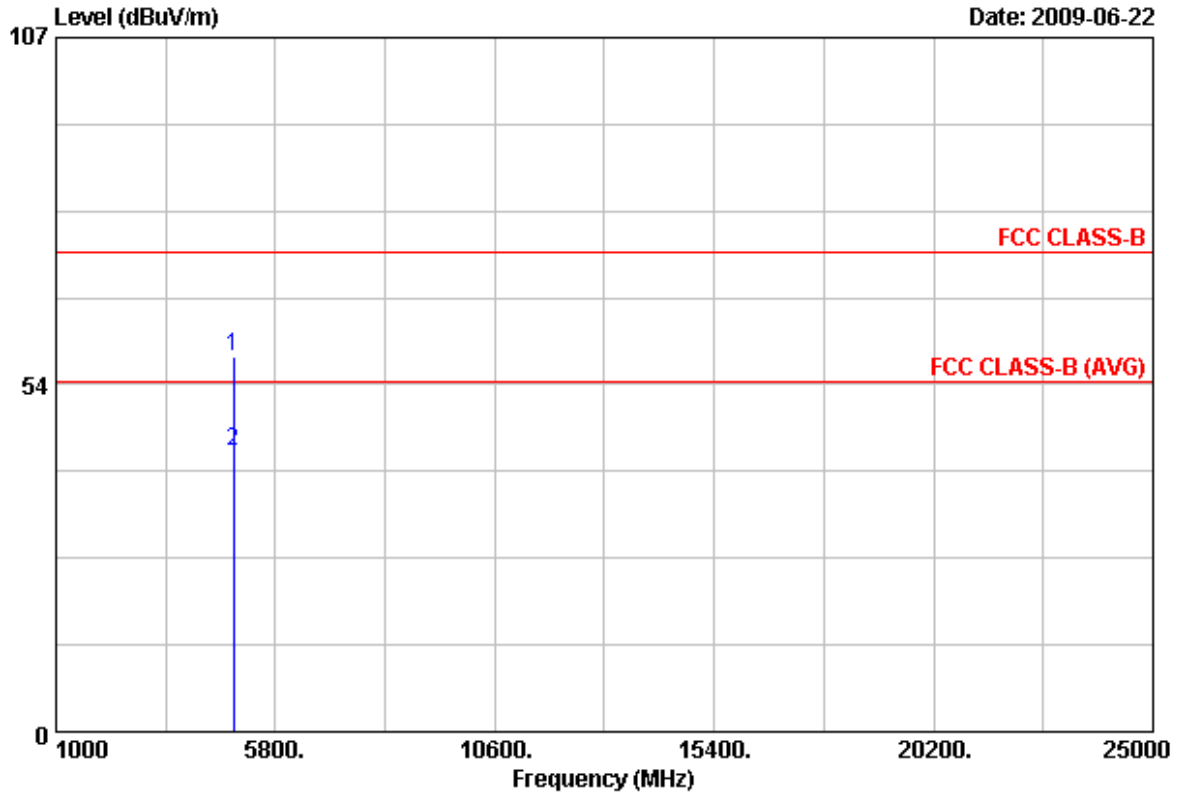

Item	Freq	Read Value	Factor	Result	Limit	Margin	Remark	Ant Pos	Tab Pos
	MHz	dBuV/m	dB	dBuV/m	dBuV/m	dB		cm	Deg
1	4874.90	49.82	7.86	57.68	74.00	-16.32	Peak	102	0
2	4878.20	35.22	7.89	43.11	54.00	-10.89	Average	102	0

Notes:

1. Result = Read Value + Factor
2. Factor = Antenna Factor + Cable Loss - Amplifier
3. The resolution bandwidth of test receiver/spectrum analyzer is 120KHz and video bandwidth is 300kHz for Peak detection and Quasi-peak detection at frequency below 1GHz.
4. The resolution bandwidth of test receiver/spectrum analyzer is 1MHz and video bandwidth is 3MHz for Peak detection at frequency above 1GHz.
5. The resolution bandwidth of test receiver/spectrum analyzer is 1MHz and video bandwidth is 10Hz for Average detection at frequency above 1GHz.
6. The other emissions is too low to be measured.



Power	: AC 120V	Pol/Phase	: HORIZONTAL
Test Mode	: 802.11g, CH6	Temperature	: 26 °C
Memo	:	Humidity	: 58 %

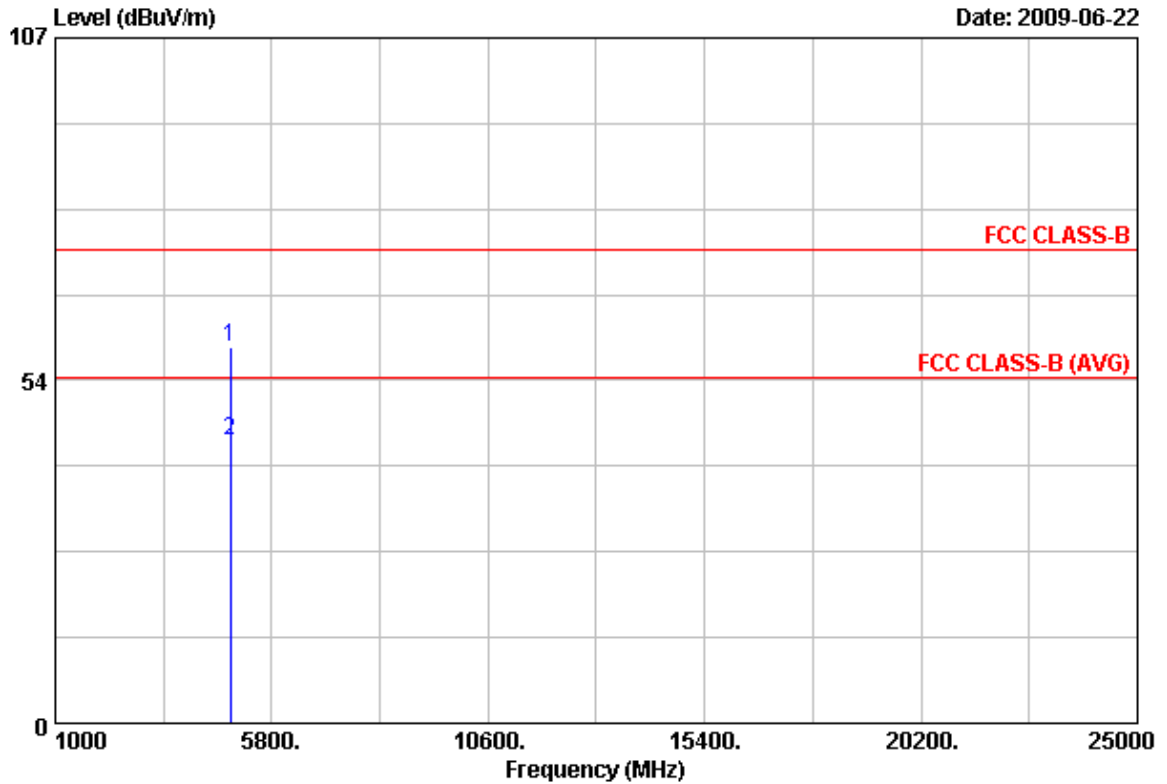

Item	Freq	Read Value	Factor	Result	Limit	Margin	Remark	Ant Pos	Tab Pos
	MHz	dBuV/m	dB	dBuV/m	dBuV/m	dB		cm	Deg
1	4874.75	50.83	7.86	58.69	74.00	-15.31	Peak	102	0
2	4877.65	36.14	7.89	44.03	54.00	-9.97	Average	102	0

Notes:

1. Result = Read Value + Factor
2. Factor = Antenna Factor + Cable Loss - Amplifier
3. The resolution bandwidth of test receiver/spectrum analyzer is 120KHz and video bandwidth is 300kHz for Peak detection and Quasi-peak detection at frequency below 1GHz.
4. The resolution bandwidth of test receiver/spectrum analyzer is 1MHz and video bandwidth is 3MHz for Peak detection at frequency above 1GHz.
5. The resolution bandwidth of test receiver/spectrum analyzer is 1MHz and video bandwidth is 10Hz for Average detection at frequency above 1GHz.
6. The other emissions is too low to be measured.



Power	: AC 120V	Pol/Phase	: VERTICAL
Test Mode	: 802.11g, CH11	Temperature	: 26 °C
Memo	:	Humidity	: 58 %

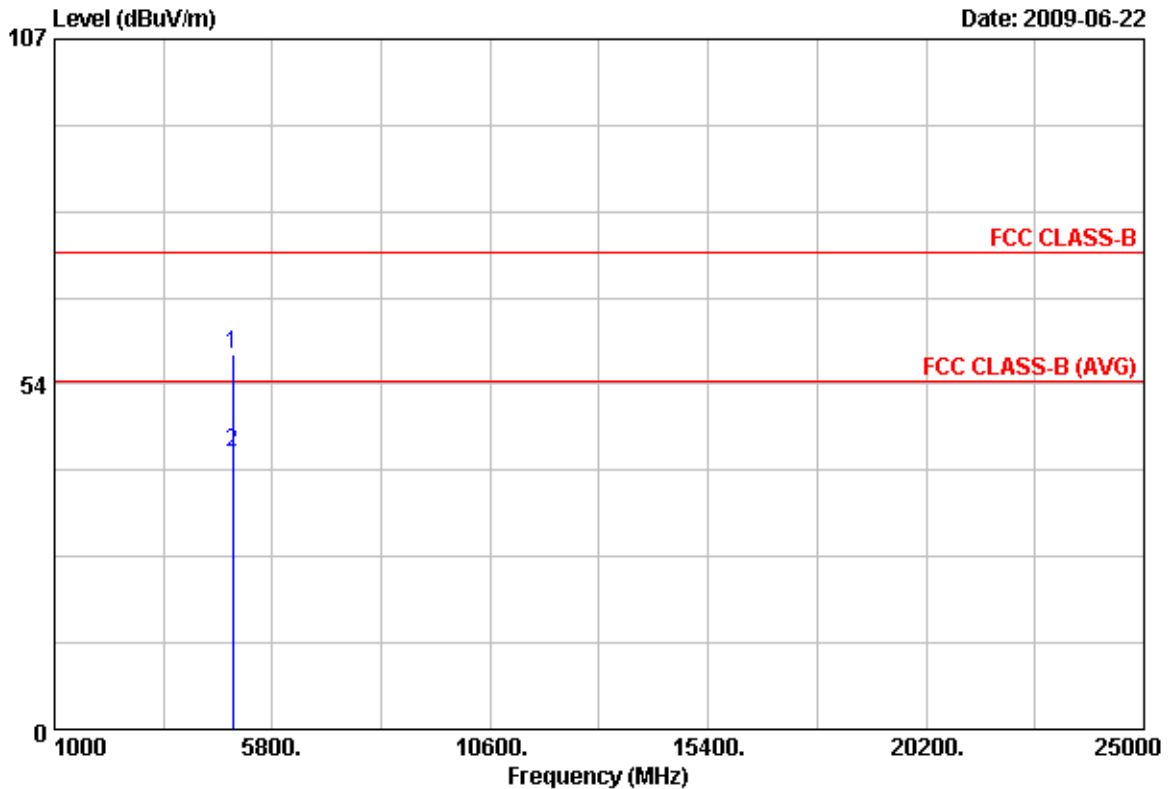

Item	Freq	Read Value	Factor	Result	Limit	Margin	Remark	Ant Pos	Tab Pos
	MHz	dBuV/m	dB	dBuV/m	dBuV/m	dB		cm	Deg
1	4924.80	50.00	8.03	58.03	74.00	-15.97	Peak	102	0
2	4928.05	34.96	8.06	43.02	54.00	-10.98	Average	102	0

Notes:

1. Result = Read Value + Factor
2. Factor = Antenna Factor + Cable Loss - Amplifier
3. The resolution bandwidth of test receiver/spectrum analyzer is 120KHz and video bandwidth is 300kHz for Peak detection and Quasi-peak detection at frequency below 1GHz.
4. The resolution bandwidth of test receiver/spectrum analyzer is 1MHz and video bandwidth is 3MHz for Peak detection at frequency above 1GHz.
5. The resolution bandwidth of test receiver/spectrum analyzer is 1MHz and video bandwidth is 10Hz for Average detection at frequency above 1GHz.
6. The other emissions is too low to be measured.



Power	: AC 120V	Pol/Phase	: HORIZONTAL
Test Mode	: 802.11g, CH11	Temperature	: 26 °C
Memo	:	Humidity	: 58 %

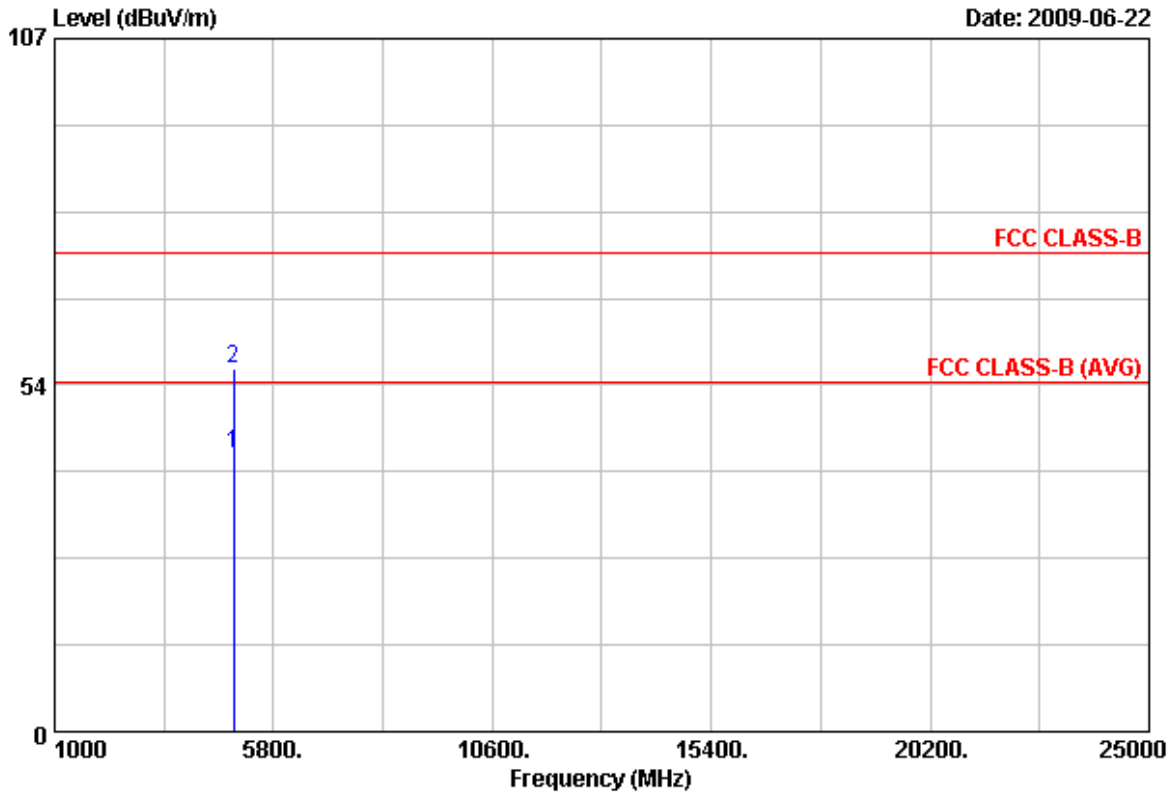

Item	Freq	Read Value	Factor	Result	Limit	Margin	Remark	Ant Pos	Tab Pos
	MHz	dBuV/m	dB	dBuV/m	dBuV/m	dB		cm	Deg
1	4924.00	34.94	8.03	42.97	54.00	-11.03	Average	102	0
2	4924.00	47.99	8.03	56.02	74.00	-17.98	Peak	102	0

Notes:

1. Result = Read Value + Factor
2. Factor = Antenna Factor + Cable Loss - Amplifier
3. The resolution bandwidth of test receiver/spectrum analyzer is 120KHz and video bandwidth is 300kHz for Peak detection and Quasi-peak detection at frequency below 1GHz.
4. The resolution bandwidth of test receiver/spectrum analyzer is 1MHz and video bandwidth is 3MHz for Peak detection at frequency above 1GHz.
5. The resolution bandwidth of test receiver/spectrum analyzer is 1MHz and video bandwidth is 10Hz for Average detection at frequency above 1GHz.
6. The other emissions is too low to be measured.



Power	: AC 120V	Pol/Phase	: VERTICAL
Test Mode	: 802.11n HT20, CH1	Temperature	: 26 °C
Memo	:	Humidity	: 58 %

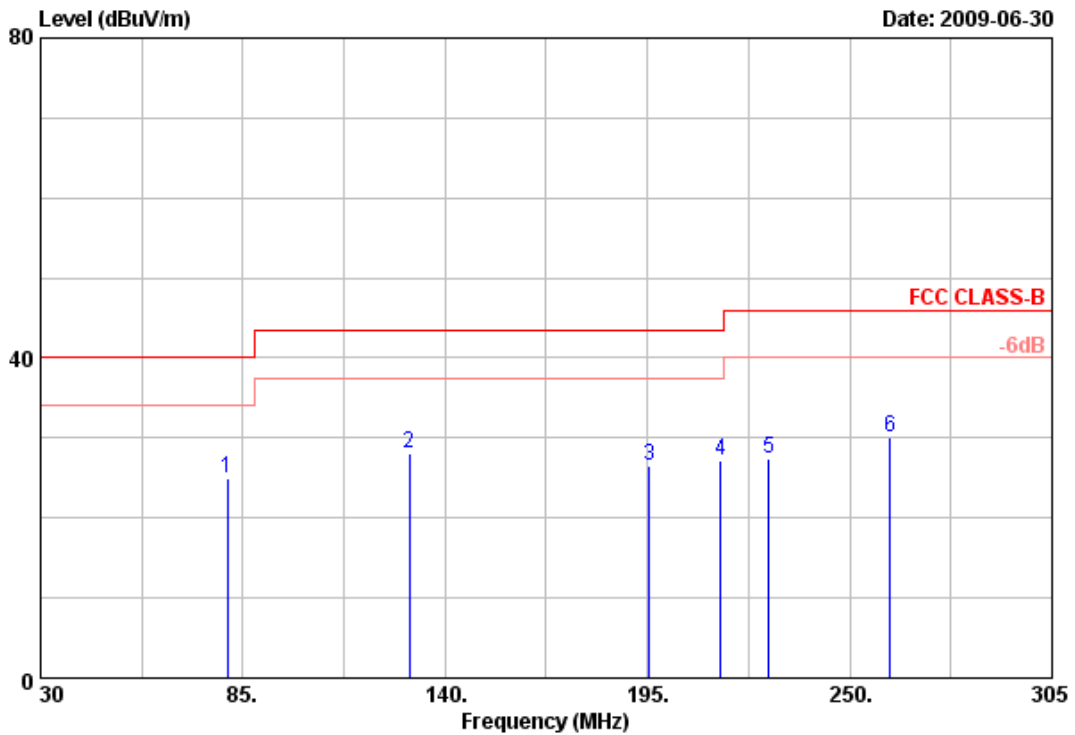

Item	Freq	Read Value	Factor	Result	Limit	Margin	Remark	Ant Pos	Tab Pos
	MHz	dBuV/m	dB	dBuV/m	dBuV/m	dB		cm	Deg
1	80.88	39.17	-14.22	24.95	40.00	-15.05	Peak	104	0
2	130.38	36.99	-8.84	28.15	43.50	-15.35	Peak	104	0
3	195.55	36.75	-10.26	26.49	43.50	-17.01	Peak	104	0
4	214.80	38.62	-11.38	27.24	43.50	-16.26	Peak	104	0
5	228.00	38.34	-11.02	27.32	46.00	-18.68	Peak	104	0
6	261.00	42.21	-12.03	30.18	46.00	-15.82	Peak	104	0

Notes:

1. Result = Read Value + Factor
2. Factor = Antenna Factor + Cable Loss - Amplifier
3. The resolution bandwidth of test receiver/spectrum analyzer is 120KHz and video bandwidth is 300kHz for Peak detection and Quasi-peak detection at frequency below 1GHz.
4. According to technical experiences, all spurious emission of 802.11MIMO mode at channel 1,6,11 are almost the same below 1GHz, so that the channel 1 was chosen as representative in final test.
5. The data is worse case.



Power	: AC 120V	Pol/Phase	: VERTICAL
Test Mode	: 802.11n HT20, CH1	Temperature	: 26 °C
Memo	:	Humidity	: 58 %

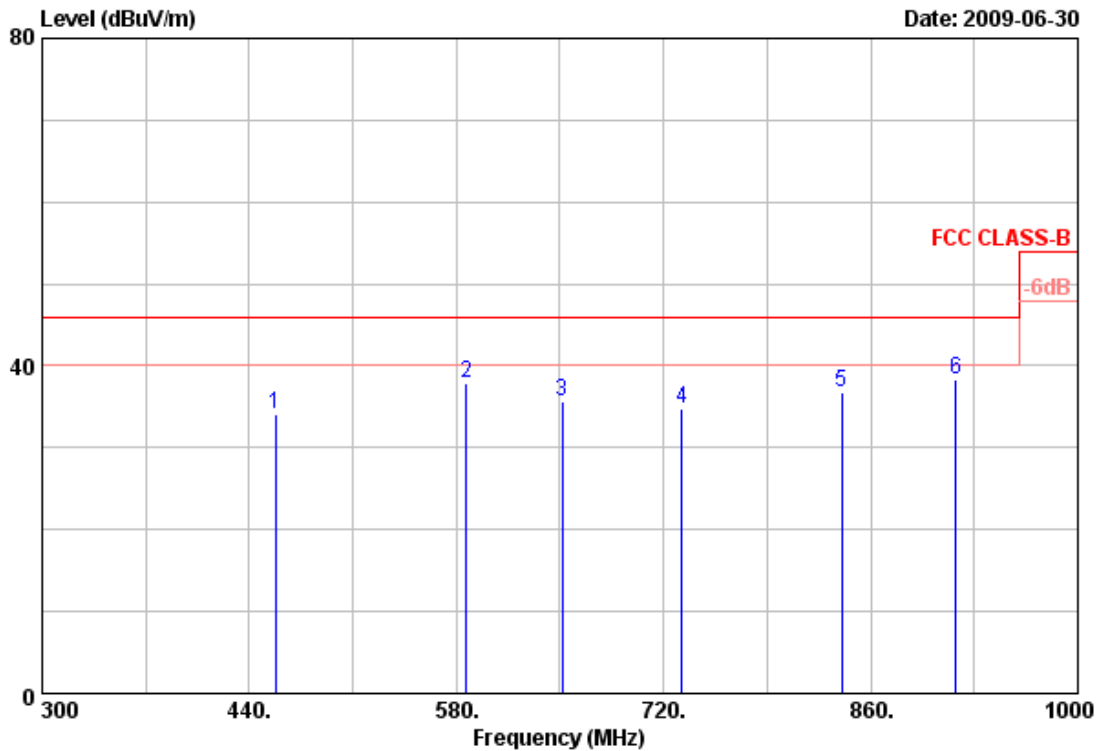

Item	Freq	Read Value	Factor	Result	Limit	Margin	Remark	Ant Pos	Tab Pos
	MHz	dBuV/m	dB	dBuV/m	dBuV/m	dB		cm	Deg
1	457.50	42.04	-8.05	33.99	46.00	-12.01	Peak	104	0
2	587.00	42.74	-4.86	37.88	46.00	-8.12	Peak	104	0
3	651.40	40.94	-5.31	35.63	46.00	-10.37	Peak	104	0
4	732.60	35.39	-0.72	34.67	46.00	-11.33	Peak	104	0
5	840.40	35.54	1.31	36.85	46.00	-9.15	Peak	104	0
6	917.40	34.18	4.12	38.30	46.00	-7.70	Peak	104	0

Notes:

1. Result = Read Value + Factor
2. Factor = Antenna Factor + Cable Loss - Amplifier
3. The resolution bandwidth of test receiver/spectrum analyzer is 120KHz and video bandwidth is 300kHz for Peak detection and Quasi-peak detection at frequency below 1GHz.
4. According to technical experiences, all spurious emission of 802.11MIMO mode at channel 1,6,11 are almost the same below 1GHz, so that the channel 1 was chosen as representative in final test.
5. The data is worse case.



Power	: AC 120V	Pol/Phase	: HORIZONTAL
Test Mode	: 802.11n HT20, CH1	Temperature	: 26 °C
Memo	:	Humidity	: 58 %

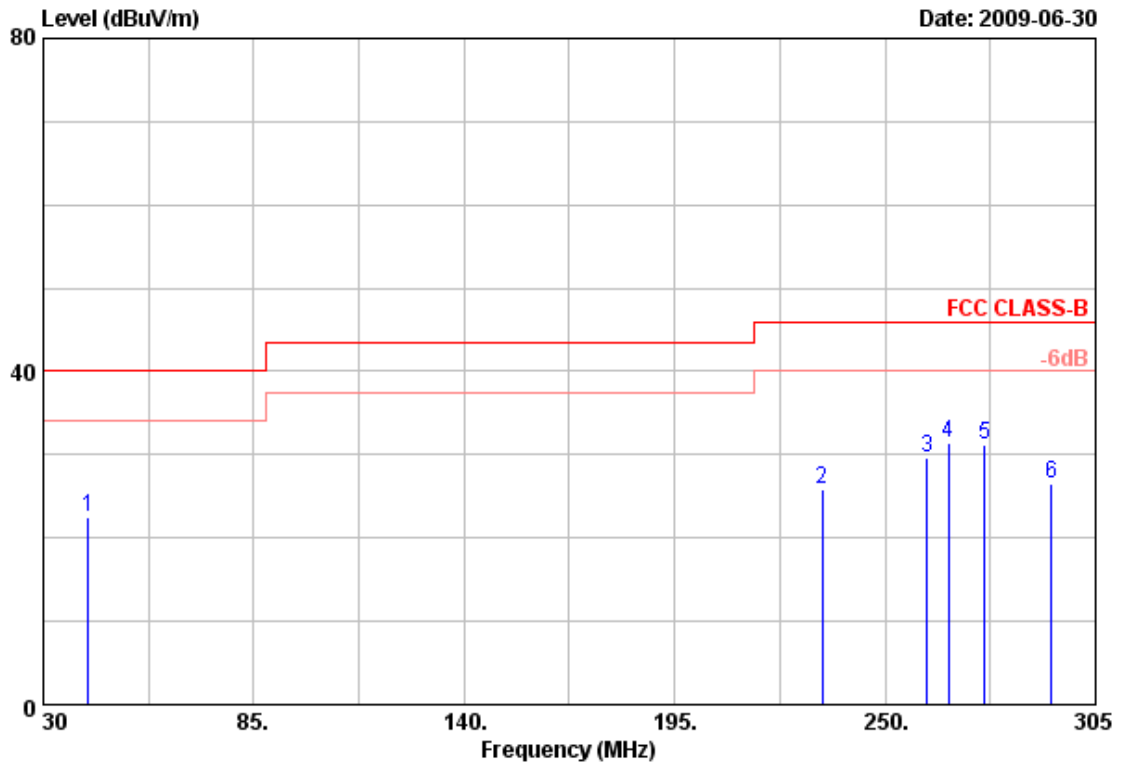

Item	Freq MHz	Read Value dBuV/m	Factor dB	Result dBuV/m	Limit dBuV/m	Margin dB	Remark	Ant Pos cm	Tab Pos Deg
1	41.83	36.92	-14.50	22.42	40.00	-17.58	Peak	104	360
2	233.50	41.97	-16.10	25.87	46.00	-20.13	Peak	104	360
3	261.00	43.47	-13.86	29.61	46.00	-16.39	Peak	104	360
4	266.50	44.91	-13.58	31.33	46.00	-14.67	Peak	104	360
5	276.13	44.29	-13.19	31.10	46.00	-14.90	Peak	104	360
6	293.45	40.15	-13.62	26.53	46.00	-19.47	Peak	104	360

Notes:

1. Result = Read Value + Factor
2. Factor = Antenna Factor + Cable Loss - Amplifier
3. The resolution bandwidth of test receiver/spectrum analyzer is 120KHz and video bandwidth is 300kHz for Peak detection and Quasi-peak detection at frequency below 1GHz.
4. According to technical experiences, all spurious emission of 802.11MIMO mode at channel 1, 6, 11 are almost the same below 1GHz, so that the channel 1 was chosen as representative in final test.
5. The data is worse case.



Power	: AC 120V	Pol/Phase	: HORIZONTAL
Test Mode	: 802.11n HT20, CH1	Temperature	: 26 °C
Memo	:	Humidity	: 58 %

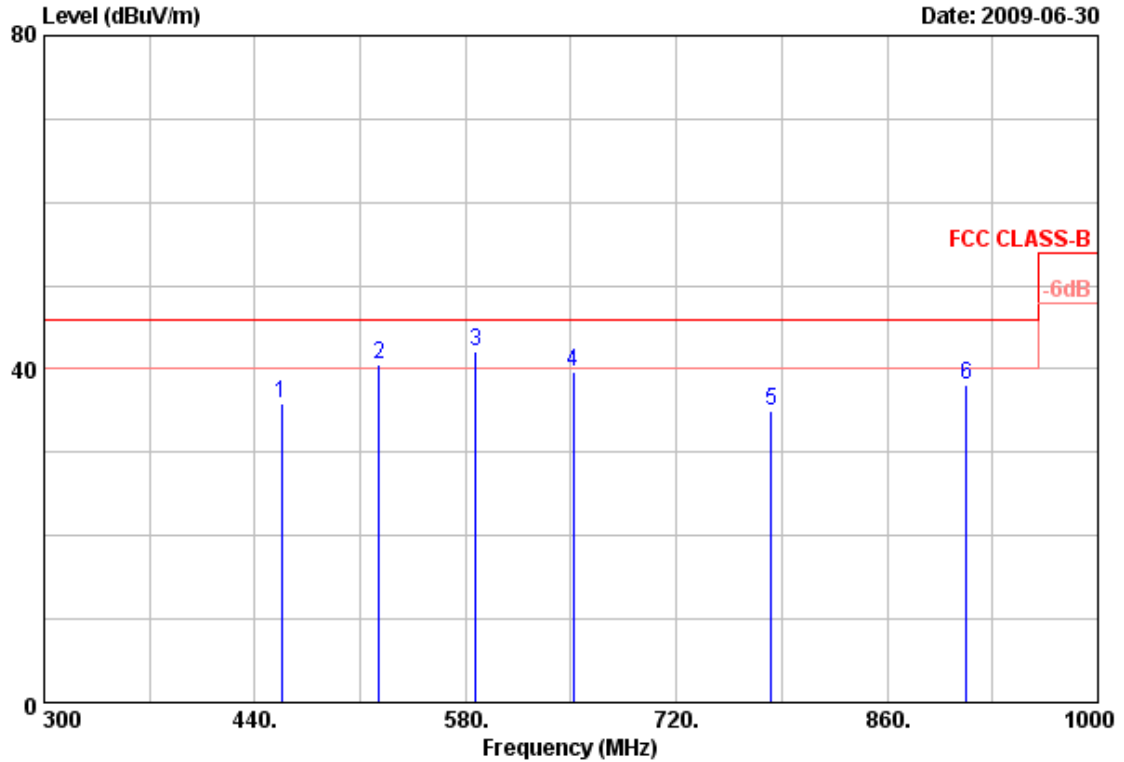

Item	Freq	Read Value	Factor	Result	Limit	Margin	Remark	Ant Pos	Tab Pos
	MHz	dBuV/m	dB	dBuV/m	dBuV/m	dB		cm	Deg
1	457.50	41.07	-5.27	35.80	46.00	-10.20	Peak	104	360
2	522.60	46.65	-6.07	40.58	46.00	-5.42	QP	104	360
3	587.00	44.22	-2.05	42.17	46.00	-3.83	QP	104	360
4	651.40	41.99	-2.36	39.63	46.00	-6.37	Peak	104	360
5	783.00	35.28	-0.22	35.06	46.00	-10.94	Peak	104	360
6	912.50	35.78	2.35	38.13	46.00	-7.87	Peak	104	360

Notes:

1. Result = Read Value + Factor
2. Factor = Antenna Factor + Cable Loss - Amplifier
3. The resolution bandwidth of test receiver/spectrum analyzer is 120KHz and video bandwidth is 300kHz for Peak detection and Quasi-peak detection at frequency below 1GHz.
4. According to technical experiences, all spurious emission of 802.11MIMO mode at channel 1,6,11 are almost the same below 1GHz, so that the channel 1 was chosen as representative in final test.
5. The data is worse case.



Power	: AC 120V	Pol/Phase	: VERTICAL
Test Mode	: 802.11n HT20, CH1	Temperature	: 26 °C
Memo	:	Humidity	: 58 %

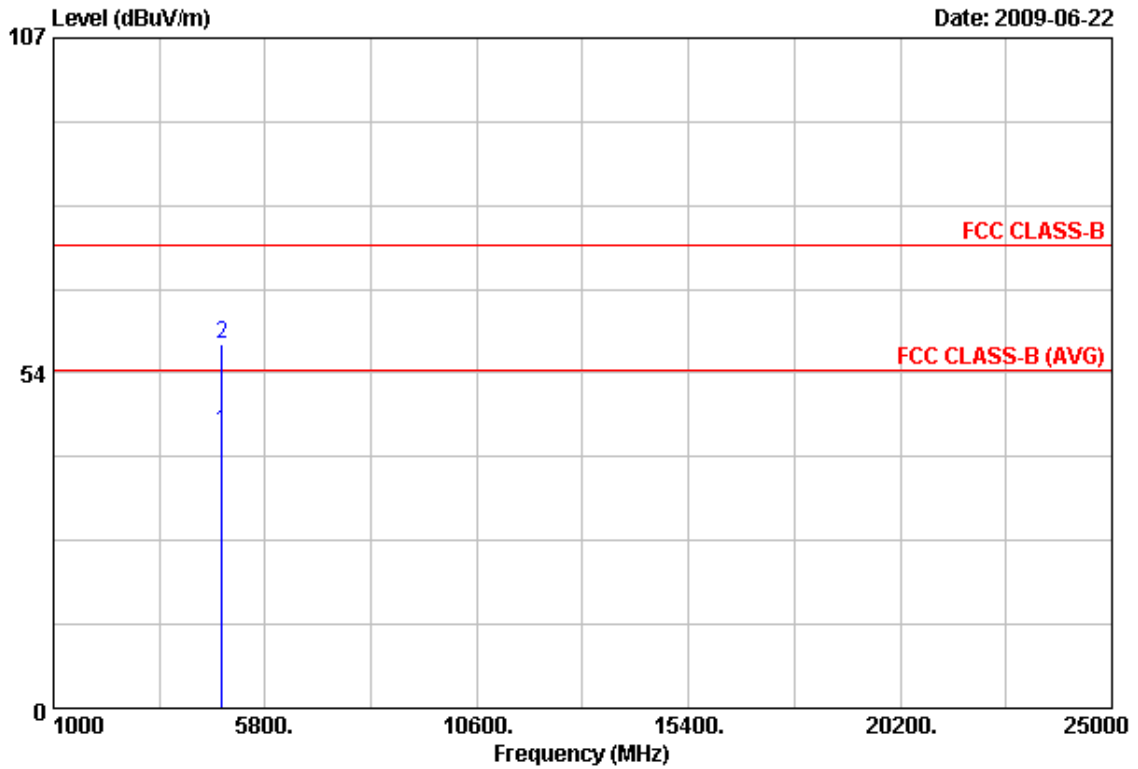

Item	Freq	Read Value	Factor	Result	Limit	Margin	Remark	Ant Pos	Tab Pos
	MHz	dBuV/m	dB	dBuV/m	dBuV/m	dB		cm	Deg
1	4822.10	36.47	7.69	44.16	54.00	-9.84	Average	102	0
2	4825.85	50.42	7.72	58.14	74.00	-15.86	Peak	102	0

Notes:

1. Result = Read Value + Factor
2. Factor = Antenna Factor + Cable Loss - Amplifier
3. The resolution bandwidth of test receiver/spectrum analyzer is 120KHz and video bandwidth is 300KHz for Peak detection and Quasi-peak detection at frequency below 1GHz.
4. The resolution bandwidth of test receiver/spectrum analyzer is 1MHz and video bandwidth is 3MHz for Peak detection at frequency above 1GHz.
5. The resolution bandwidth of test receiver/spectrum analyzer is 1MHz and video bandwidth is 10Hz for Average detection at frequency above 1GHz.
6. The other emissions is too low to be measured.



Power	: AC 120V	Pol/Phase	: HORIZONTAL
Test Mode	: 802.11n HT20, CH1	Temperature	: 26 °C
Memo	:	Humidity	: 58 %

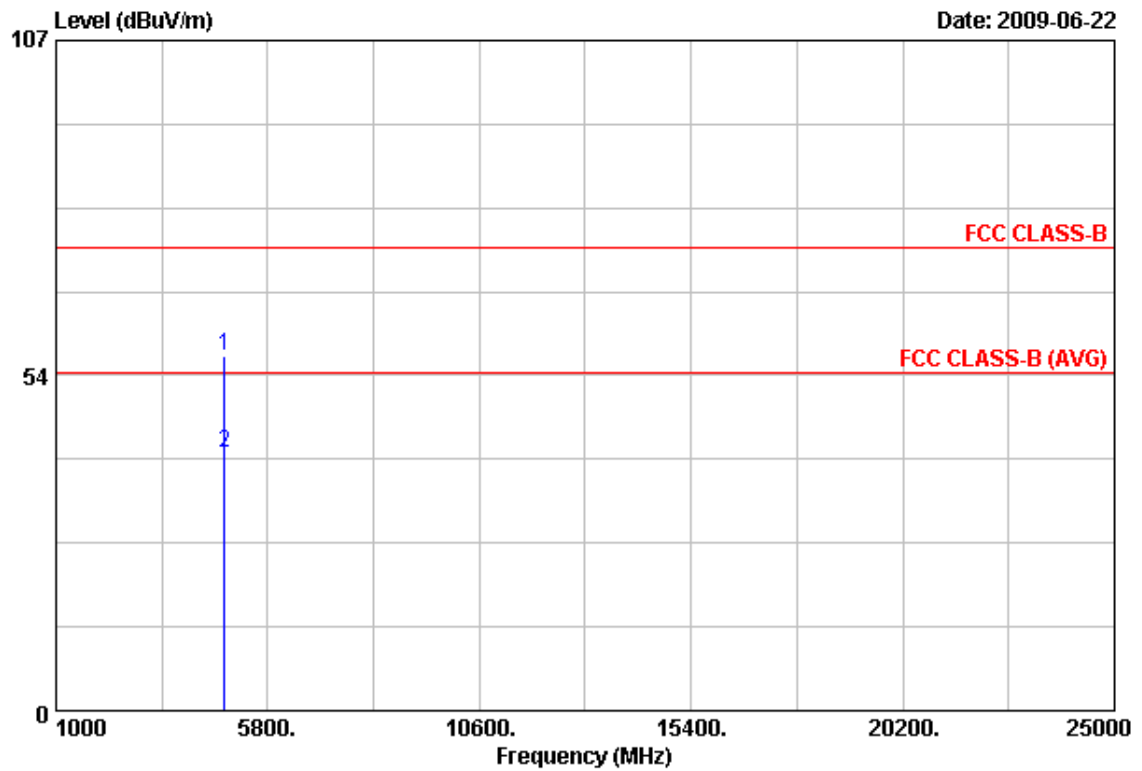

Item	Freq	Read Value	Factor	Result	Limit	Margin	Remark	Ant Pos	Tab Pos
	MHz	dBuV/m	dB	dBuV/m	dBuV/m	dB		cm	Deg
1	4822.65	49.03	7.69	56.72	74.00	-17.28	Peak	102	0
2	4824.65	33.48	7.69	41.17	54.00	-12.83	Average	102	0

Notes:

1. Result = Read Value + Factor
2. Factor = Antenna Factor + Cable Loss - Amplifier
3. The resolution bandwidth of test receiver/spectrum analyzer is 120KHz and video bandwidth is 300kHz for Peak detection and Quasi-peak detection at frequency below 1GHz.
4. The resolution bandwidth of test receiver/spectrum analyzer is 1MHz and video bandwidth is 3MHz for Peak detection at frequency above 1GHz.
5. The resolution bandwidth of test receiver/spectrum analyzer is 1MHz and video bandwidth is 10Hz for Average detection at frequency above 1GHz.
6. The other emissions is too low to be measured.



Power	: AC 120V	Pol/Phase	: VERTICAL
Test Mode	: 802.11n HT20, CH6	Temperature	: 26 °C
Memo	: EUT with PC	Humidity	: 58 %

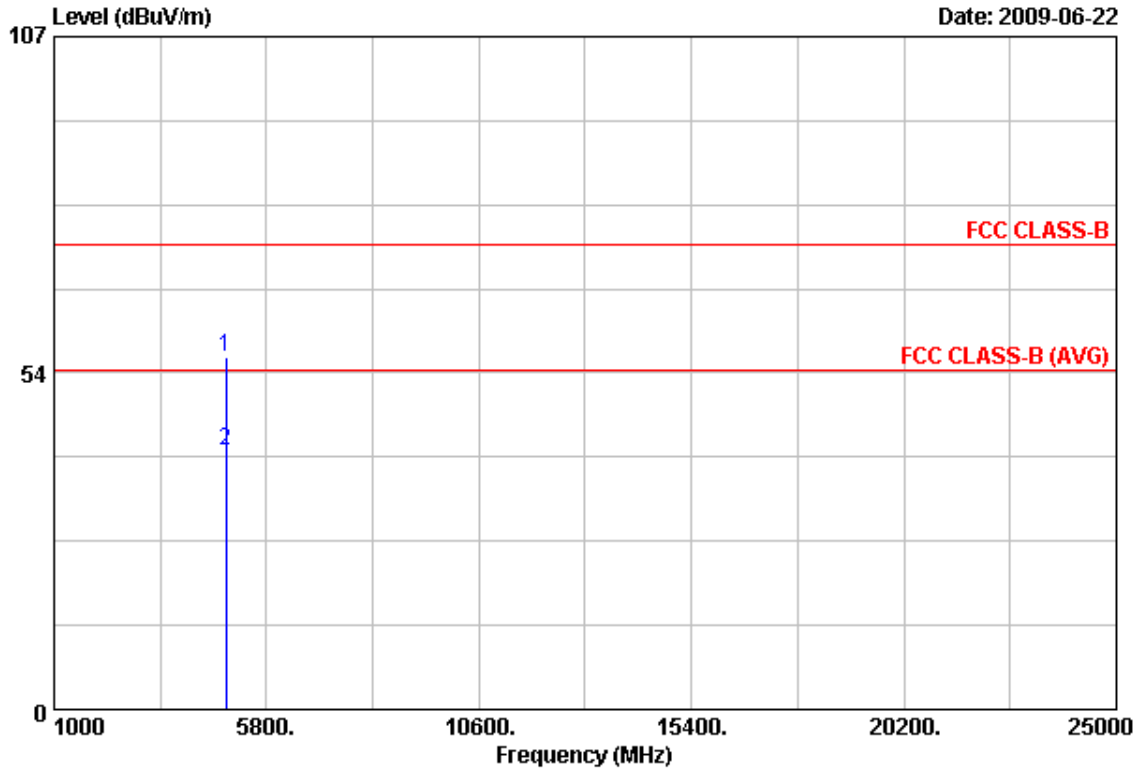

Item	Freq	Read Value	Factor	Result	Limit	Margin	Remark	Ant Pos	Tab Pos
	MHz	dBuV/m	dB	dBuV/m	dBuV/m	dB		cm	Deg
1	4874.45	48.08	7.86	55.94	74.00	-18.06	Peak	102	0
2	4876.00	33.21	7.89	41.10	54.00	-12.90	Average	102	0

Notes:

1. Result = Read Value + Factor
2. Factor = Antenna Factor + Cable Loss - Amplifier
3. The resolution bandwidth of test receiver/spectrum analyzer is 120KHz and video bandwidth is 300kHz for Peak detection and Quasi-peak detection at frequency below 1GHz.
4. The resolution bandwidth of test receiver/spectrum analyzer is 1MHz and video bandwidth is 3MHz for Peak detection at frequency above 1GHz.
5. The resolution bandwidth of test receiver/spectrum analyzer is 1MHz and video bandwidth is 10Hz for Average detection at frequency above 1GHz.
6. The other emissions is too low to be measured.



Power	: AC 120V	Pol/Phase	: HORIZONTAL
Test Mode	: 802.11n HT20, CH6	Temperature	: 26 °C
Memo	:	Humidity	: 58 %

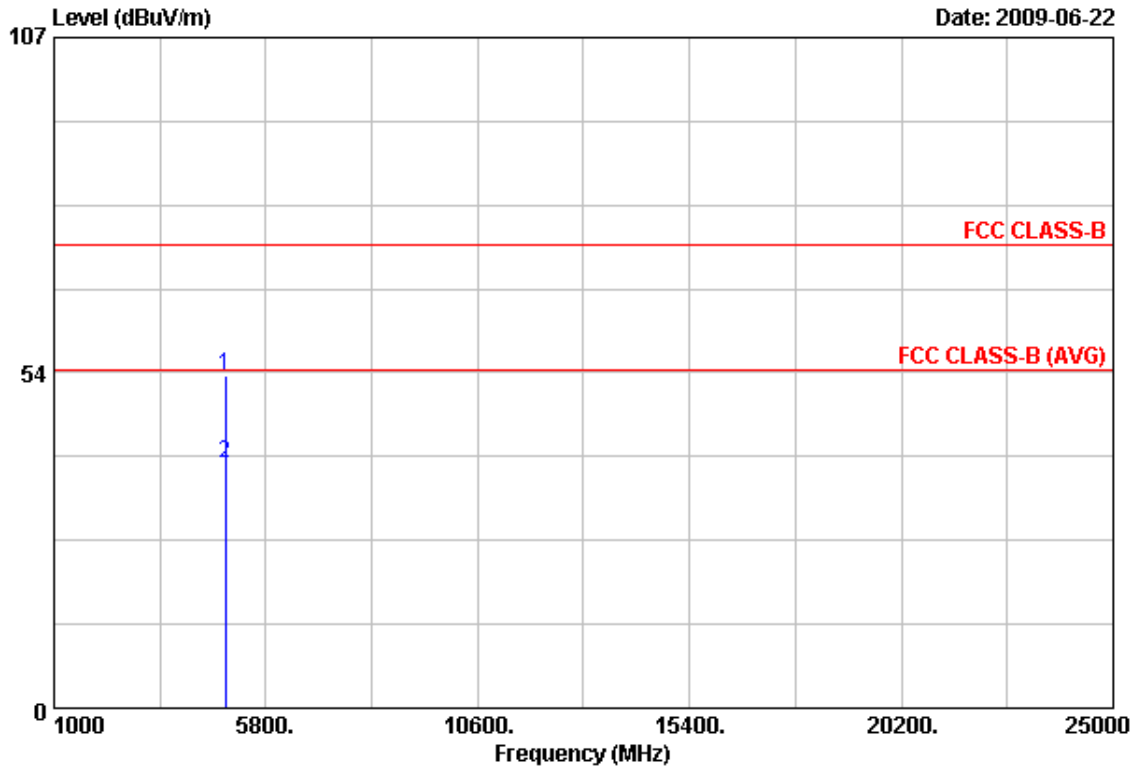

Item	Freq	Read Value	Factor	Result	Limit	Margin	Remark	Ant Pos	Tab Pos
	MHz	dBUV/m	dB	dBUV/m	dBUV/m	dB		cm	Deg
1	4874.75	45.13	7.86	52.99	74.00	-21.01	Peak	102	0
2	4877.95	31.11	7.89	39.00	54.00	-15.00	Average	102	0

Notes:

1. Result = Read Value + Factor
2. Factor = Antenna Factor + Cable Loss - Amplifier
3. The resolution bandwidth of test receiver/spectrum analyzer is 120KHz and video bandwidth is 300kHz for Peak detection and Quasi-peak detection at frequency below 1GHz.
4. The resolution bandwidth of test receiver/spectrum analyzer is 1MHz and video bandwidth is 3MHz for Peak detection at frequency above 1GHz.
5. The resolution bandwidth of test receiver/spectrum analyzer is 1MHz and video bandwidth is 10Hz for Average detection at frequency above 1GHz.
6. The other emissions is too low to be measured.



Power	: AC 120V	Pol/Phase	: VERTICAL
Test Mode	: 802.11n HT20, CH11	Temperature	: 26 °C
Memo	:	Humidity	: 58 %

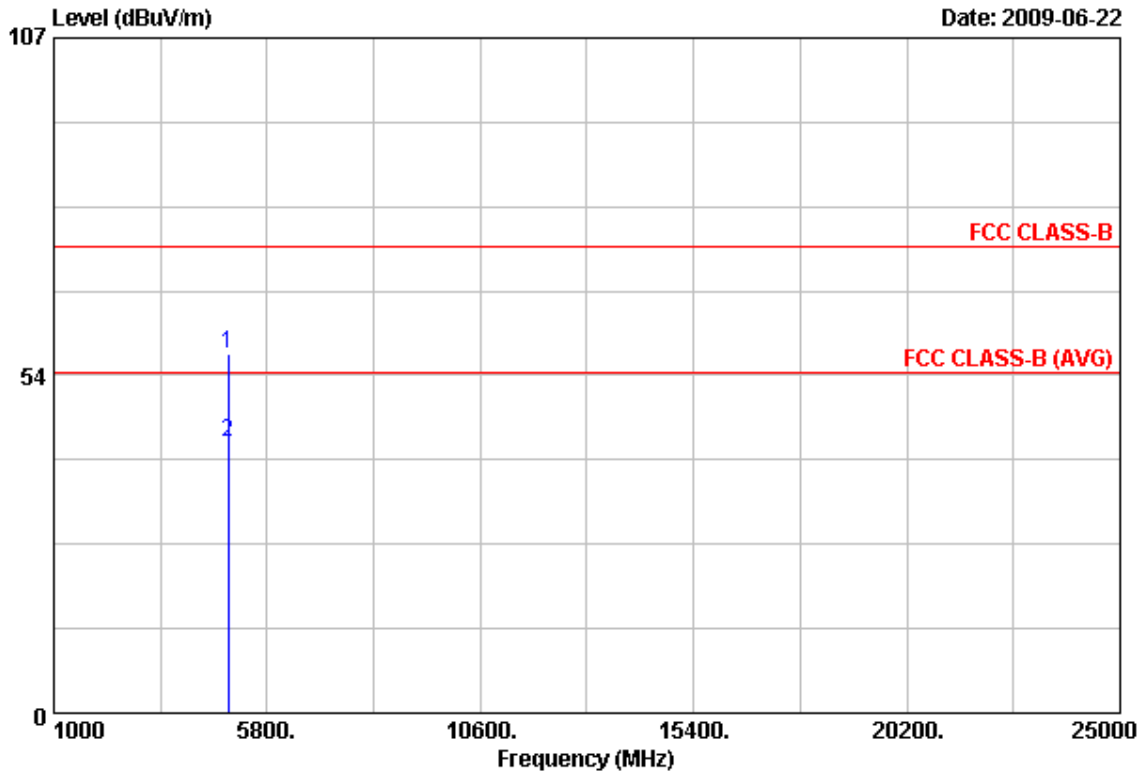

Item	Freq	Read Value	Factor	Result	Limit	Margin	Remark	Ant Pos	Tab Pos
	MHz	dBuV/m	dB	dBuV/m	dBuV/m	dB		cm	Deg
1	4924.95	48.95	8.03	56.98	74.00	-17.02	Peak	102	0
2	4925.55	34.85	8.06	42.91	54.00	-11.09	Average	102	0

Notes:

1. Result = Read Value + Factor
2. Factor = Antenna Factor + Cable Loss - Amplifier
3. The resolution bandwidth of test receiver/spectrum analyzer is 120KHz and video bandwidth is 300kHz for Peak detection and Quasi-peak detection at frequency below 1GHz.
4. The resolution bandwidth of test receiver/spectrum analyzer is 1MHz and video bandwidth is 3MHz for Peak detection at frequency above 1GHz.
5. The resolution bandwidth of test receiver/spectrum analyzer is 1MHz and video bandwidth is 10Hz for Average detection at frequency above 1GHz.
6. The other emissions is too low to be measured.



Power	: AC 120V	Pol/Phase	: HORIZONTAL
Test Mode	: 802.11n HT20, CH11	Temperature	: 26 °C
Memo	:	Humidity	: 58 %

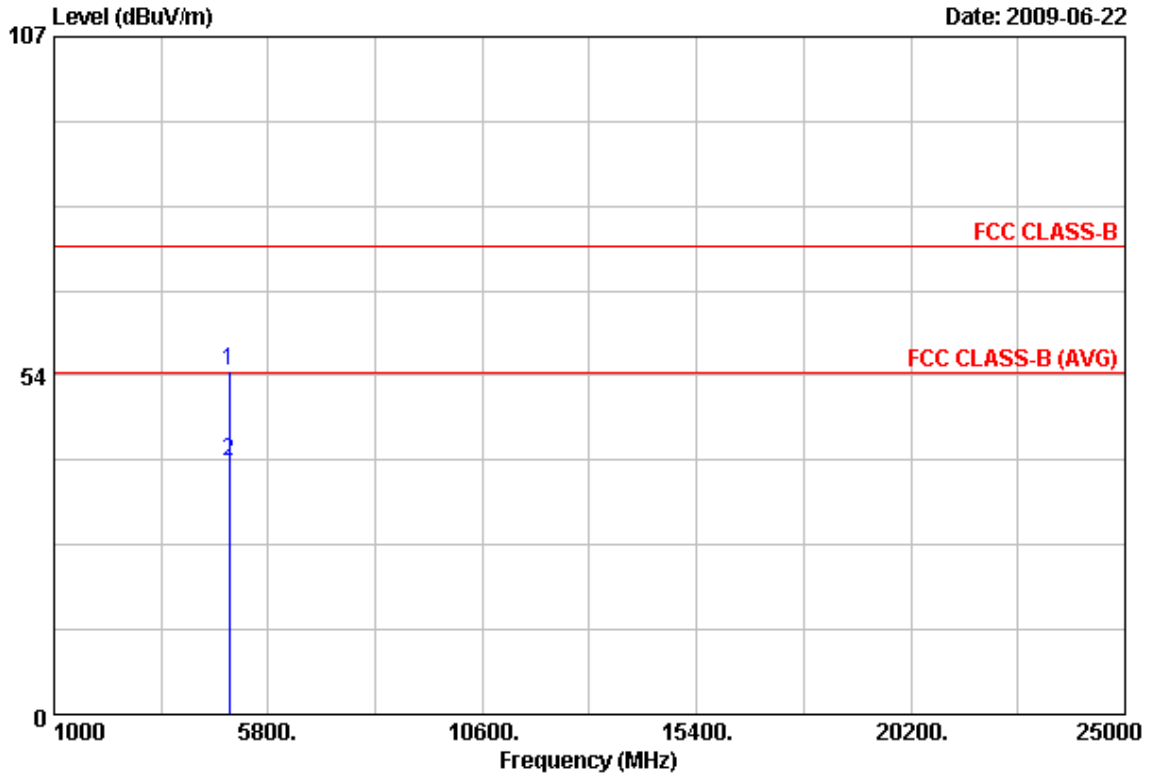

Item	Freq	Read Value	Factor	Result	Limit	Margin	Remark	Ant Pos	Tab Pos
	MHz	dBuV/m	dB	dBuV/m	dBuV/m	dB		cm	Deg
1	4924.95	46.33	8.03	54.36	74.00	-19.64	Peak	103	0
2	4927.95	31.89	8.06	39.95	54.00	-14.05	Average	103	0

Notes:

1. Result = Read Value + Factor
2. Factor = Antenna Factor + Cable Loss - Amplifier
3. The resolution bandwidth of test receiver/spectrum analyzer is 120KHz and video bandwidth is 300kHz for Peak detection and Quasi-peak detection at frequency below 1GHz.
4. The resolution bandwidth of test receiver/spectrum analyzer is 1MHz and video bandwidth is 3MHz for Peak detection at frequency above 1GHz.
5. The resolution bandwidth of test receiver/spectrum analyzer is 1MHz and video bandwidth is 10Hz for Average detection at frequency above 1GHz.
6. The other emissions is too low to be measured.



Power	: AC 120V	Pol/Phase	: VERTICAL
Test Mode	: 802.11n HT40, CH3	Temperature	: 26 °C
Memo	:	Humidity	: 58 %

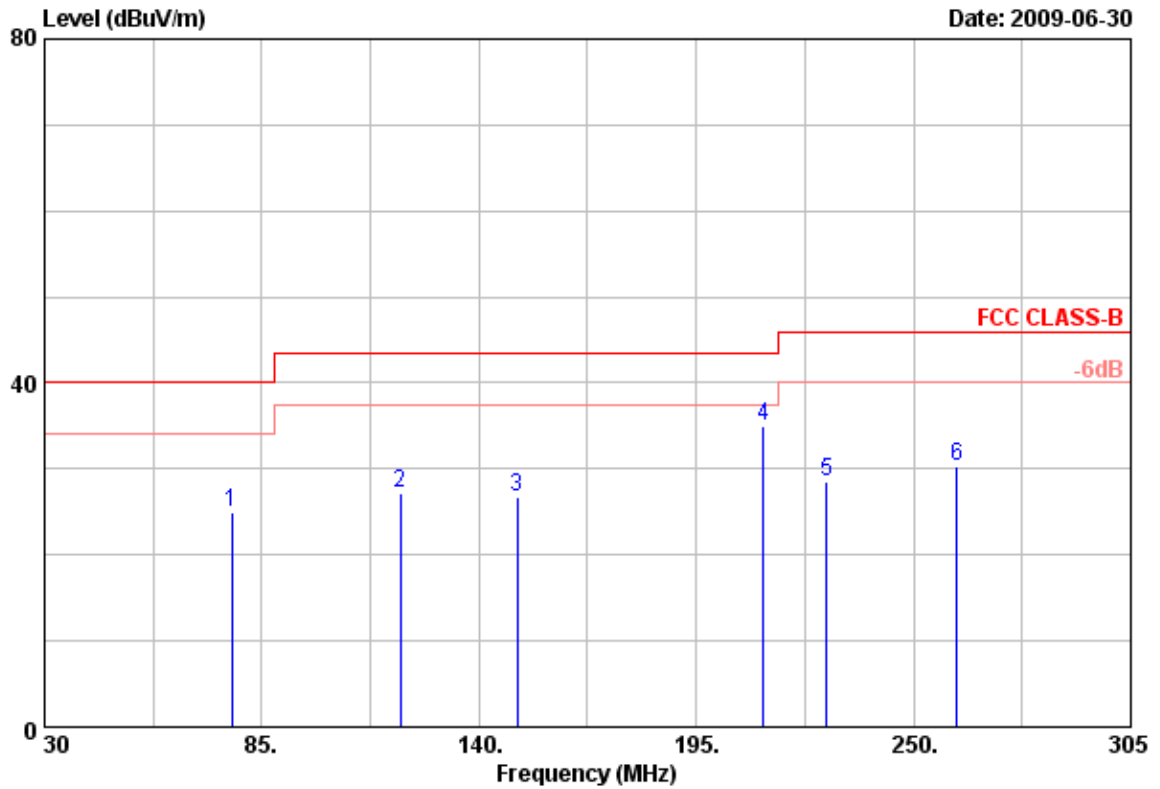

Item	Freq	Read Value	Factor	Result	Limit	Margin	Remark	Ant Pos	Tab Pos
	MHz	dBuV/m	dB	dBuV/m	dBuV/m	dB		cm	Deg
1	77.30	39.90	-14.84	25.06	40.00	-14.94	Peak	104	0
2	120.20	37.43	-10.19	27.24	43.50	-16.26	Peak	104	0
3	149.63	38.01	-11.25	26.76	43.50	-16.74	Peak	104	0
4	212.05	45.74	-10.73	35.01	43.50	-8.49	Peak	104	0
5	228.00	39.52	-11.02	28.50	46.00	-17.50	Peak	104	0
6	261.00	42.24	-12.03	30.21	46.00	-15.79	Peak	104	0

Notes:

1. Result = Read Value + Factor
2. Factor = Antenna Factor + Cable Loss - Amplifier
3. The resolution bandwidth of test receiver/spectrum analyzer is 120KHz and video bandwidth is 300kHz for Peak detection and Quasi-peak detection at frequency below 1GHz.
4. According to technical experiences, all spurious emission of 802.11MIMO mode at channel 3,6,9 are almost the same below 1GHz, so that the channel 3 was chosen as representative in final test.
5. The data is worse case.



Power	: AC 120V	Pol/Phase	: VERTICAL
Test Mode	: 802.11n HT40, CH3	Temperature	: 26 °C
Memo	:	Humidity	: 58 %

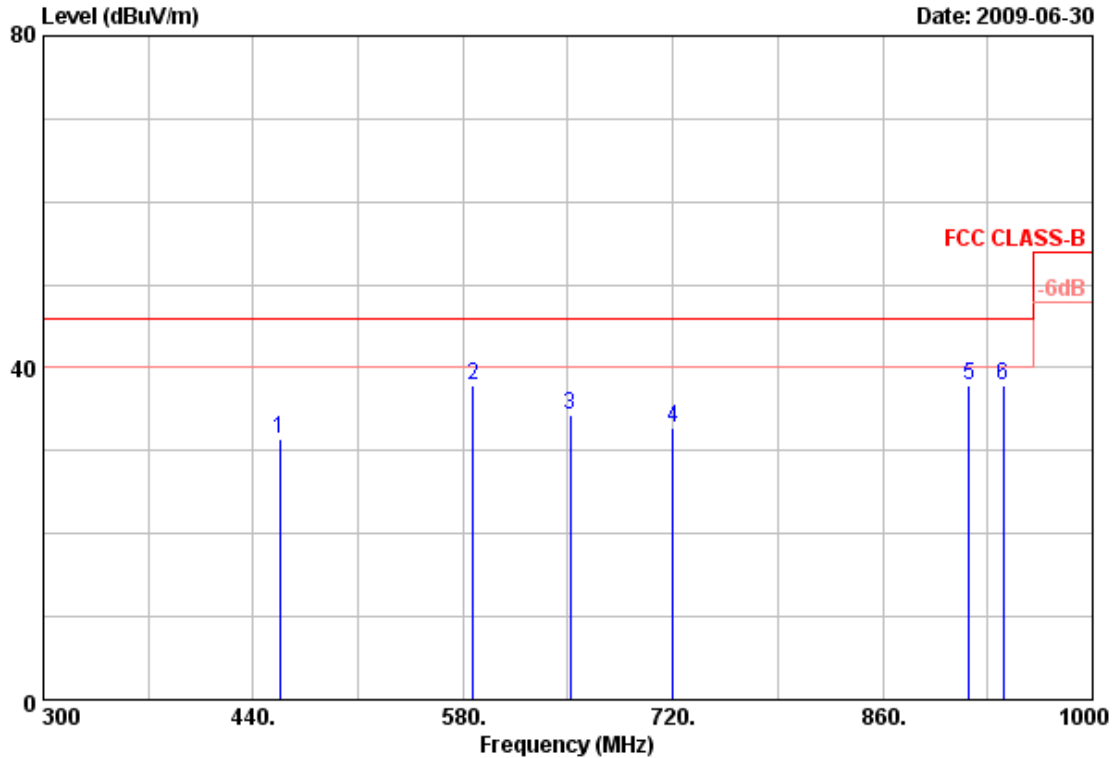

Item	Freq	Read Value	Factor	Result	Limit	Margin	Remark	Ant Pos	Tab Pos
	MHz	dBuV/m	dB	dBuV/m	dBuV/m	dB		cm	Deg
1	457.50	39.48	-8.05	31.43	46.00	-14.57	Peak	104	0
2	587.00	42.67	-4.86	37.81	46.00	-8.19	Peak	104	0
3	651.40	39.62	-5.31	34.31	46.00	-11.69	Peak	104	0
4	720.00	34.47	-1.71	32.76	46.00	-13.24	Peak	104	0
5	917.40	33.68	4.12	37.80	46.00	-8.20	Peak	104	0
6	940.50	33.62	4.23	37.85	46.00	-8.15	Peak	104	0

Notes:

1. Result = Read Value + Factor
2. Factor = Antenna Factor + Cable Loss - Amplifier
3. The resolution bandwidth of test receiver/spectrum analyzer is 120KHz and video bandwidth is 300kHz for Peak detection and Quasi-peak detection at frequency below 1GHz.
4. According to technical experiences, all spurious emission of 802.11MIMO mode at channel 3,6,9 are almost the same below 1GHz, so that the channel 3 was chosen as representative in final test.
5. The data is worse case.



Power	: AC 120V	Pol/Phase	: HORIZONTAL
Test Mode	: 802.11n HT40, CH3	Temperature	: 26 °C
Memo	:	Humidity	: 58 %

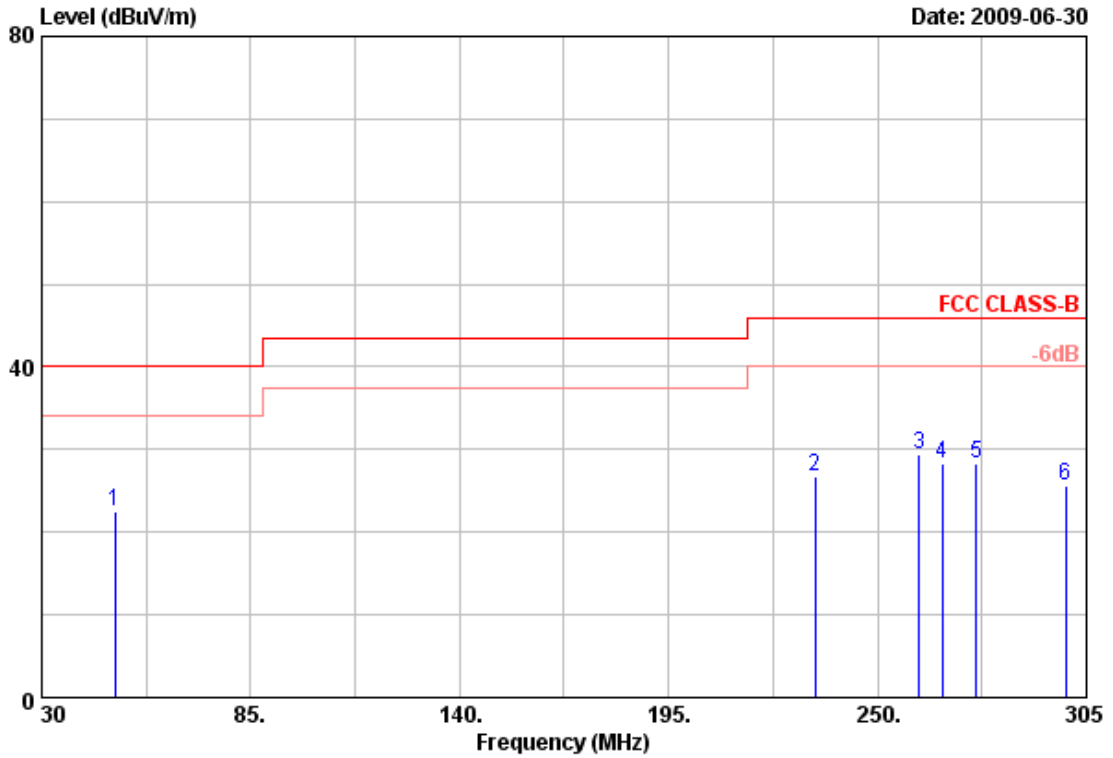

Item	Freq	Read Value	Factor	Result	Limit	Margin	Remark	Ant Pos	Tab Pos
	MHz	dBuV/m	dB	dBuV/m	dBuV/m	dB		cm	Deg
1	49.25	37.00	-14.52	22.48	40.00	-17.52	Peak	104	360
2	233.50	42.88	-16.10	26.78	46.00	-19.22	Peak	104	360
3	261.00	43.29	-13.86	29.43	46.00	-16.57	Peak	104	360
4	267.05	41.81	-13.53	28.28	46.00	-17.72	Peak	104	360
5	276.13	41.50	-13.19	28.31	46.00	-17.69	Peak	104	360
6	299.50	38.67	-13.08	25.59	46.00	-20.41	Peak	104	360

Notes:

1. Result = Read Value + Factor
2. Factor = Antenna Factor + Cable Loss - Amplifier
3. The resolution bandwidth of test receiver/spectrum analyzer is 120KHz and video bandwidth is 300kHz for Peak detection and Quasi-peak detection at frequency below 1GHz.
4. According to technical experiences, all spurious emission of 802.11MIMO mode at channel 3,6,9 are almost the same below 1GHz, so that the channel 3 was chosen as representative in final test.
5. The data is worse case.



Power	: AC 120V	Pol/Phase	: HORIZONTAL
Test Mode	: 802.11n HT40, CH3	Temperature	: 26 °C
Memo	:	Humidity	: 58 %

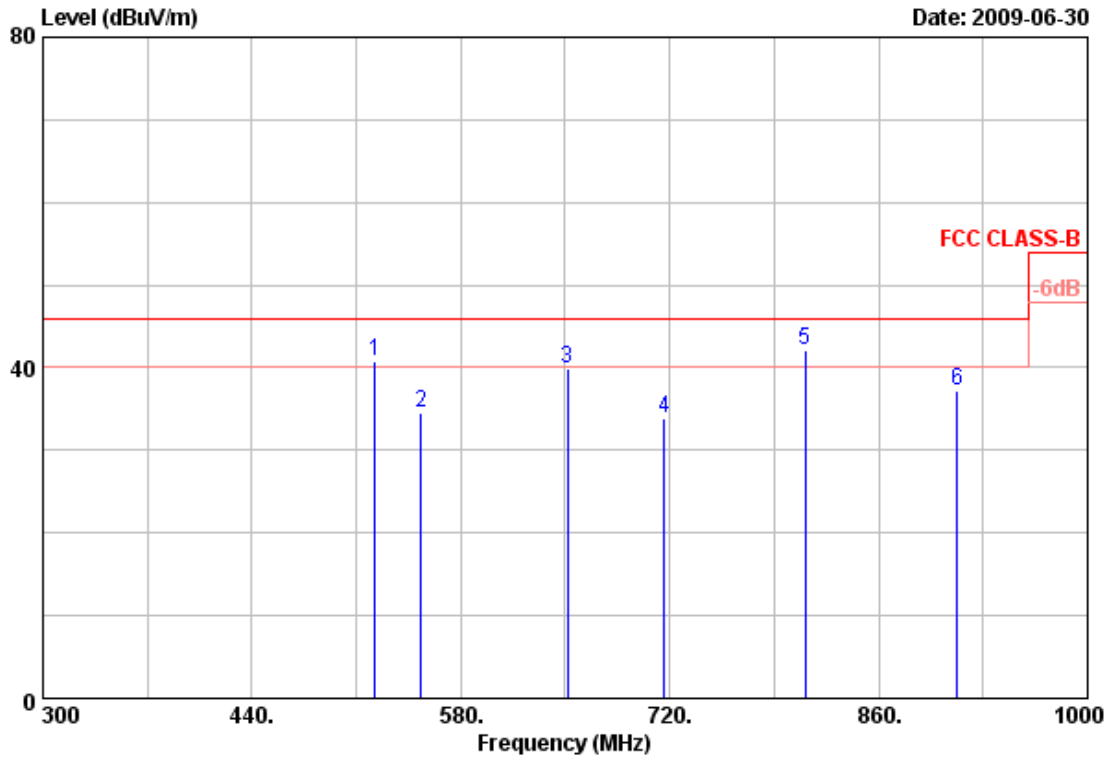

Item	Freq	Read Value	Factor	Result	Limit	Margin	Remark	Ant Pos	Tab Pos
	MHz	dBuV/m	dB	dBuV/m	dBuV/m	dB		cm	Deg
1	522.60	46.86	-6.07	40.79	46.00	-5.21	QP	104	360
2	553.40	37.12	-2.56	34.56	46.00	-11.44	Peak	104	360
3	651.40	42.23	-2.36	39.87	46.00	-6.13	Peak	104	360
4	716.50	37.03	-3.18	33.85	46.00	-12.15	Peak	104	360
5	811.00	42.43	-0.31	42.12	46.00	-3.88	QP	104	360
6	912.50	34.90	2.35	37.25	46.00	-8.75	Peak	104	360

Notes:

1. Result = Read Value + Factor
2. Factor = Antenna Factor + Cable Loss - Amplifier
3. The resolution bandwidth of test receiver/spectrum analyzer is 120KHz and video bandwidth is 300kHz for Peak detection and Quasi-peak detection at frequency below 1GHz.
4. According to technical experiences, all spurious emission of 802.11MIMO mode at channel 3,6,9 are almost the same below 1GHz, so that the channel 3 was chosen as representative in final test.
5. The data is worse case.



Power	: AC 120V	Pol/Phase	: VERTICAL
Test Mode	: 802.11n HT40, CH3	Temperature	: 26 °C
Memo	:	Humidity	: 58 %

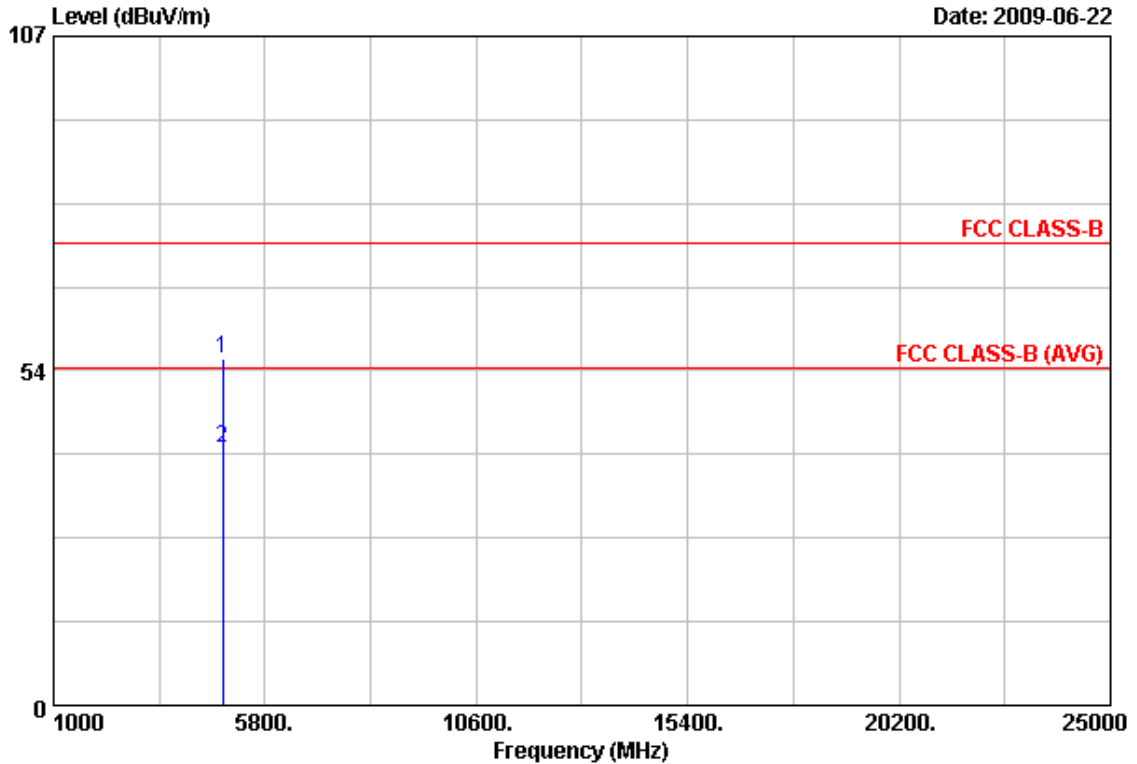

Item	Freq	Read Value	Factor	Result	Limit	Margin	Remark	Ant Pos	Tab Pos
	MHz	dBuV/m	dB	dBuV/m	dBuV/m	dB		cm	Deg
1	4843.60	47.73	7.77	55.50	74.00	-18.50	Peak	103	0
2	4845.50	33.36	7.77	41.13	54.00	-12.87	Average	103	0

Notes:

1. Result = Read Value + Factor
2. Factor = Antenna Factor + Cable Loss - Amplifier
3. The resolution bandwidth of test receiver/spectrum analyzer is 120KHz and video bandwidth is 300kHz for Peak detection and Quasi-peak detection at frequency below 1GHz.
4. The resolution bandwidth of test receiver/spectrum analyzer is 1MHz and video bandwidth is 3MHz for Peak detection at frequency above 1GHz.
5. The resolution bandwidth of test receiver/spectrum analyzer is 1MHz and video bandwidth is 10Hz for Average detection at frequency above 1GHz.
6. The other emissions is too low to be measured.



Power	: AC 120V	Pol/Phase	: HORIZONTAL
Test Mode	: 802.11n HT40, CH3	Temperature	: 26 °C
Memo	:	Humidity	: 58 %

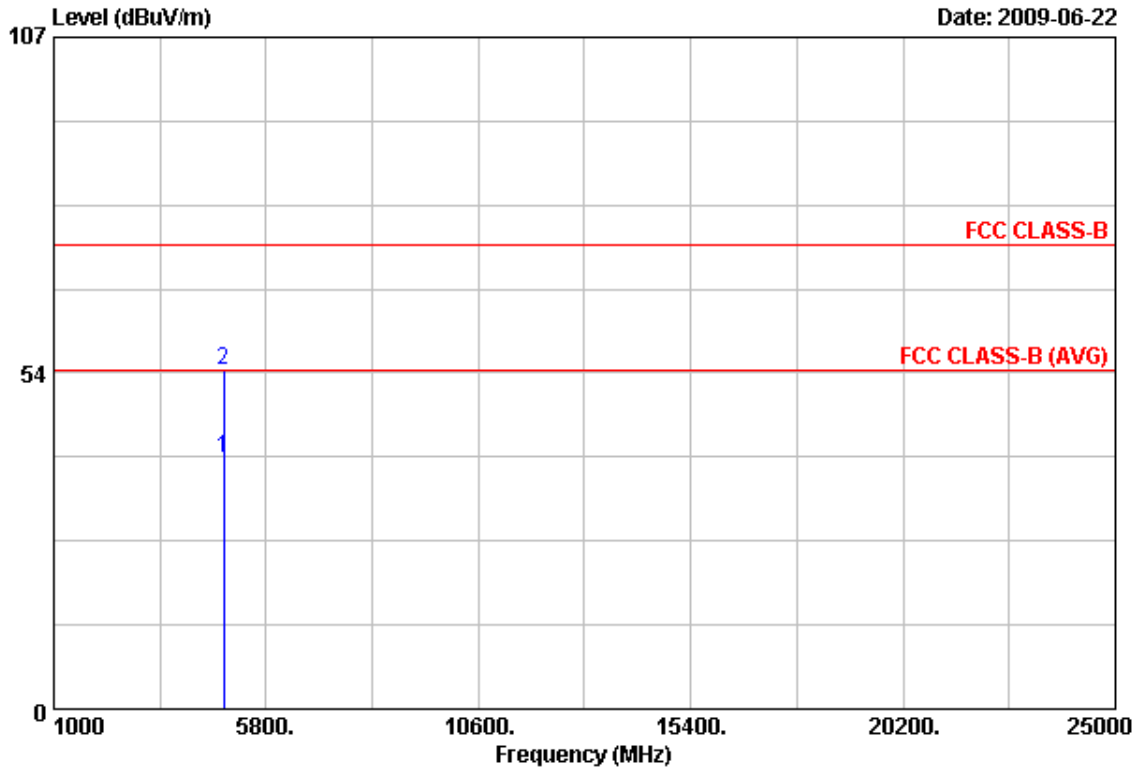

Item	Freq	Read Value	Factor	Result	Limit	Margin	Remark	Ant Pos	Tab Pos
	MHz	dBuV/m	dB	dBuV/m	dBuV/m	dB		cm	Deg
1	4845.55	32.07	7.77	39.84	54.00	-14.16	Average	103	0
2	4848.35	46.01	7.79	53.80	74.00	-20.20	Peak	103	0

Notes:

1. Result = Read Value + Factor
2. Factor = Antenna Factor + Cable Loss - Amplifier
3. The resolution bandwidth of test receiver/spectrum analyzer is 120KHz and video bandwidth is 300kHz for Peak detection and Quasi-peak detection at frequency below 1GHz.
4. The resolution bandwidth of test receiver/spectrum analyzer is 1MHz and video bandwidth is 3MHz for Peak detection at frequency above 1GHz.
5. The resolution bandwidth of test receiver/spectrum analyzer is 1MHz and video bandwidth is 10Hz for Average detection at frequency above 1GHz.
6. The other emissions is too low to be measured.



Power	: AC 120V	Pol/Phase	: VERTICAL
Test Mode	: 802.11n HT40, CH6	Temperature	: 26 °C
Memo	:	Humidity	: 58 %

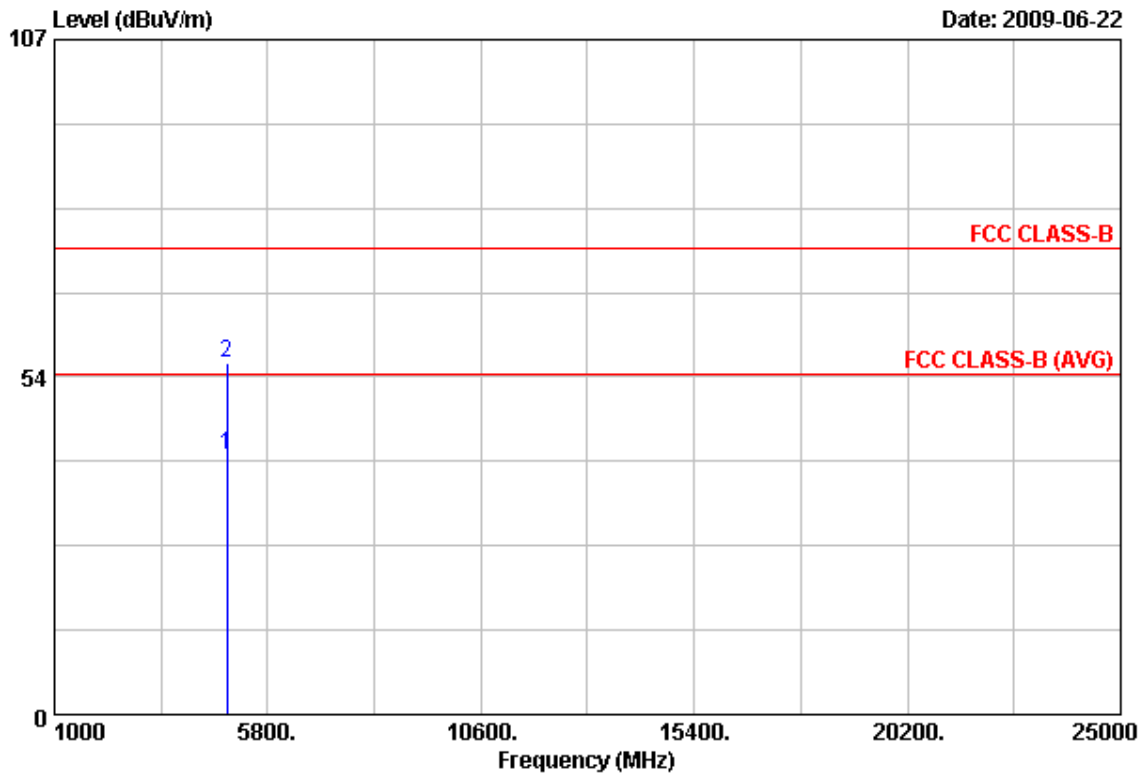

Item	Freq	Read Value	Factor	Result	Limit	Margin	Remark	Ant Pos	Tab Pos
	MHz	dBuV/m	dB	dBuV/m	dBuV/m	dB		cm	Deg
1	4874.30	33.39	7.86	41.25	54.00	-12.75	Average	103	0
2	4874.95	47.80	7.86	55.66	74.00	-18.34	Peak	103	0

Notes:

1. Result = Read Value + Factor
2. Factor = Antenna Factor + Cable Loss - Amplifier
3. The resolution bandwidth of test receiver/spectrum analyzer is 120KHz and video bandwidth is 300kHz for Peak detection and Quasi-peak detection at frequency below 1GHz.
4. The resolution bandwidth of test receiver/spectrum analyzer is 1MHz and video bandwidth is 3MHz for Peak detection at frequency above 1GHz.
5. The resolution bandwidth of test receiver/spectrum analyzer is 1MHz and video bandwidth is 10Hz for Average detection at frequency above 1GHz.
6. The other emissions is too low to be measured.



Power	: AC 120V	Pol/Phase	: HORIZONTAL
Test Mode	: 802.11n HT40, CH6	Temperature	: 26 °C
Memo	:	Humidity	: 58 %

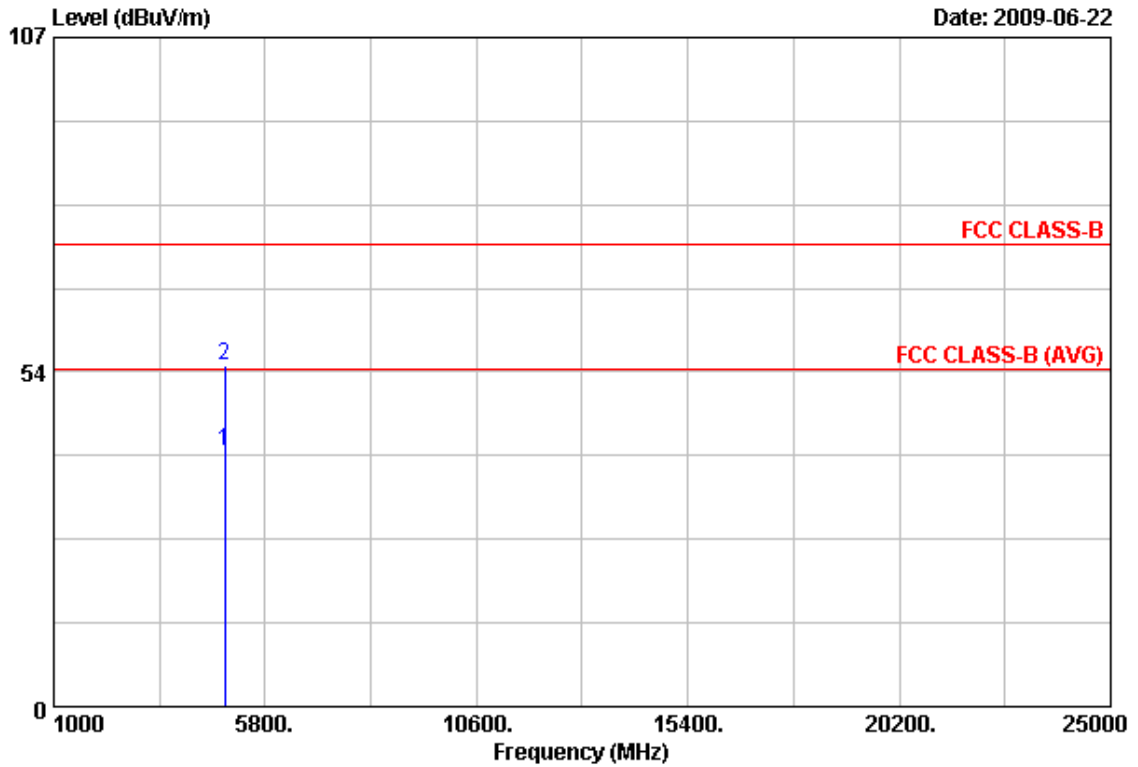

Item	Freq	Read Value	Factor	Result	Limit	Margin	Remark	Ant Pos	Tab Pos
	MHz	dBuV/m	dB	dBuV/m	dBuV/m	dB		cm	Deg
1	4874.80	32.92	7.86	40.78	54.00	-13.22	Average	103	0
2	4876.15	46.55	7.89	54.44	74.00	-19.56	Peak	103	0

Notes:

1. Result = Read Value + Factor
2. Factor = Antenna Factor + Cable Loss - Amplifier
3. The resolution bandwidth of test receiver/spectrum analyzer is 120KHz and video bandwidth is 300kHz for Peak detection and Quasi-peak detection at frequency below 1GHz.
4. The resolution bandwidth of test receiver/spectrum analyzer is 1MHz and video bandwidth is 3MHz for Peak detection at frequency above 1GHz.
5. The resolution bandwidth of test receiver/spectrum analyzer is 1MHz and video bandwidth is 10Hz for Average detection at frequency above 1GHz.
6. The other emissions is too low to be measured.



Power	: AC 120V	Pol/Phase	: VERTICAL
Test Mode	: 802.11n HT40, CH9	Temperature	: 26 °C
Memo	:	Humidity	: 58 %

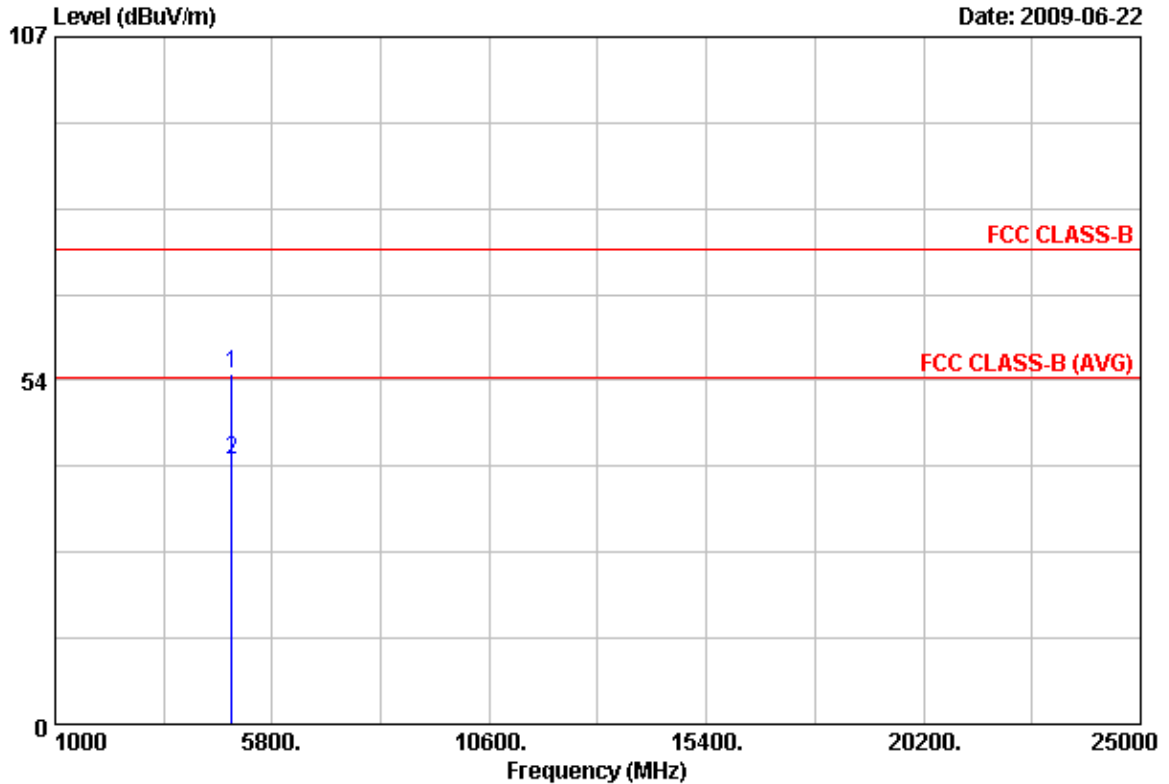

Item	Freq	Read Value	Factor	Result	Limit	Margin	Remark	Ant Pos	Tab Pos
	MHz	dBuV/m	dB	dBuV/m	dBuV/m	dB		cm	Deg
1	4904.40	46.46	7.98	54.44	74.00	-19.56	Peak	103	0
2	4910.90	32.98	8.00	40.98	54.00	-13.02	Average	103	0

Notes:

1. Result = Read Value + Factor
2. Factor = Antenna Factor + Cable Loss - Amplifier
3. The resolution bandwidth of test receiver/spectrum analyzer is 120KHz and video bandwidth is 300kHz for Peak detection and Quasi-peak detection at frequency below 1GHz.
4. The resolution bandwidth of test receiver/spectrum analyzer is 1MHz and video bandwidth is 3MHz for Peak detection at frequency above 1GHz.
5. The resolution bandwidth of test receiver/spectrum analyzer is 1MHz and video bandwidth is 10Hz for Average detection at frequency above 1GHz.
6. The other emissions is too low to be measured.



Power	: AC 120V	Pol/Phase	: HORIZONTAL
Test Mode	: 802.11n HT40, CH9	Temperature	: 26 °C
Memo	:	Humidity	: 58 %

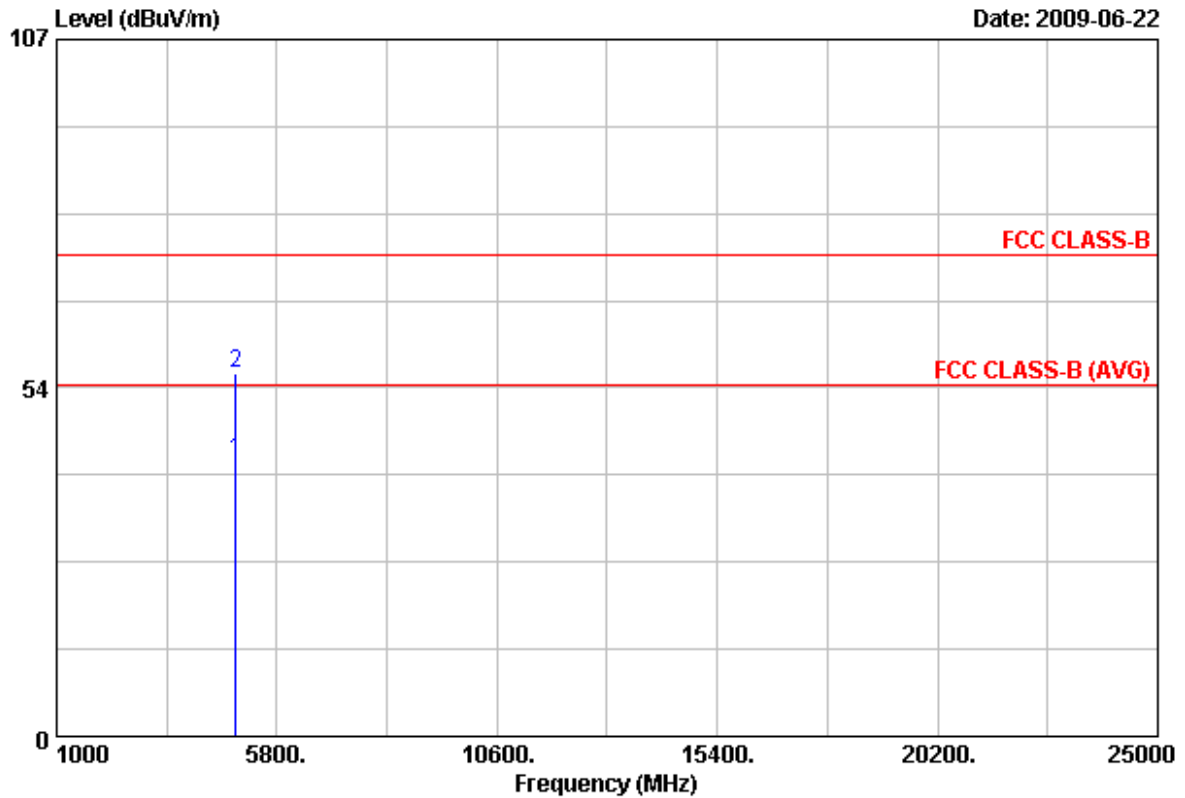

Item	Freq	Read Value	Factor	Result	Limit	Margin	Remark	Ant Pos	Tab Pos
	MHz	dBuV/m	dB	dBuV/m	dBuV/m	dB		cm	Deg
1	4904.90	34.41	7.98	42.39	54.00	-11.61	Average	103	0
2	4905.05	47.65	7.98	55.63	74.00	-18.37	Peak	103	0

Notes:

1. Result = Read Value + Factor
2. Factor = Antenna Factor + Cable Loss - Amplifier
3. The resolution bandwidth of test receiver/spectrum analyzer is 120KHz and video bandwidth is 300kHz for Peak detection and Quasi-peak detection at frequency below 1GHz.
4. The resolution bandwidth of test receiver/spectrum analyzer is 1MHz and video bandwidth is 3MHz for Peak detection at frequency above 1GHz.
5. The resolution bandwidth of test receiver/spectrum analyzer is 1MHz and video bandwidth is 10Hz for Average detection at frequency above 1GHz.
6. The other emissions is too low to be measured.



Power	: AC 120V	Pol/Phase	: VERTICAL
Test Mode	: 802.11a, CH149	Temperature	: 26 °C
Memo	:	Humidity	: 58 %

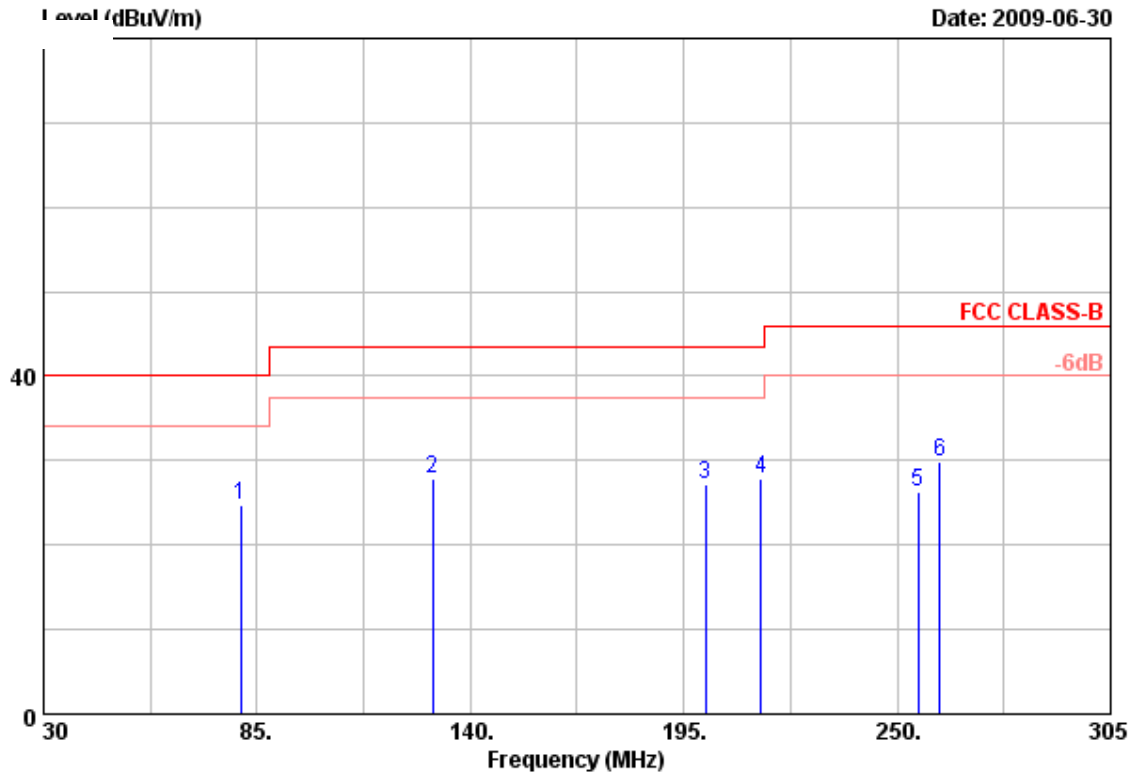

Item	Freq	Read Value	Factor	Result	Limit	Margin	Remark	Ant Pos	Tab Pos
	MHz	dBuV/m	dB	dBuV/m	dBuV/m	dB		cm	Deg
1	80.88	39.01	-14.22	24.79	40.00	-15.21	Peak	104	0
2	130.38	36.64	-8.84	27.80	43.50	-15.70	Peak	104	0
3	200.50	36.61	-9.47	27.14	43.50	-16.36	Peak	104	0
4	214.80	39.16	-11.38	27.78	43.50	-15.72	Peak	104	0
5	255.50	39.14	-12.93	26.21	46.00	-19.79	Peak	104	0
6	261.00	41.83	-12.03	29.80	46.00	-16.20	Peak	104	0

Notes:

1. Result = Read Value + Factor
2. Factor = Antenna Factor + Cable Loss - Amplifier
3. The resolution bandwidth of test receiver/spectrum analyzer is 120KHz and video bandwidth is 300kHz for Peak detection and Quasi-peak detection at frequency below 1GHz.
4. According to technical experiences, all spurious emission of 802.11a mode at channel 149,157,165 are almost the same below 1GHz, so that the channel 149 was chosen as representative in final test.
5. The data is worse case.



Power	: AC 120V	Pol/Phase	: VERTICAL
Test Mode	: 802.11a, CH149	Temperature	: 26 °C
Memo	:	Humidity	: 58 %

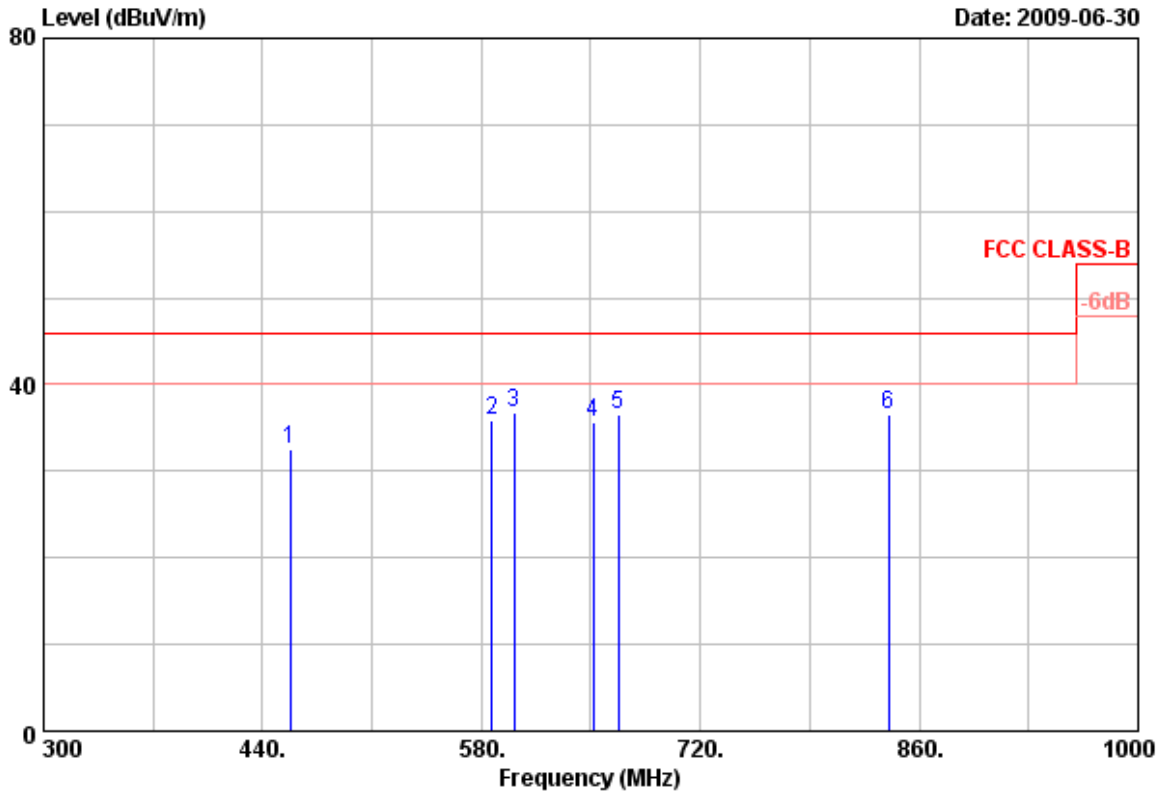

Item	Freq	Read Value	Factor	Result	Limit	Margin	Remark	Ant Pos	Tab Pos
	MHz	dBuV/m	dB	dBuV/m	dBuV/m	dB		cm	Deg
1	457.50	40.58	-8.05	32.53	46.00	-13.47	Peak	104	0
2	587.00	40.80	-4.86	35.94	46.00	-10.06	Peak	104	0
3	601.00	41.78	-4.99	36.79	46.00	-9.21	Peak	104	0
4	651.40	40.94	-5.31	35.63	46.00	-10.37	Peak	104	0
5	667.50	40.56	-3.94	36.62	46.00	-9.38	Peak	104	0
6	840.40	35.30	1.31	36.61	46.00	-9.39	Peak	104	0

Notes:

1. Result = Read Value + Factor
2. Factor = Antenna Factor + Cable Loss - Amplifier
3. The resolution bandwidth of test receiver/spectrum analyzer is 120KHz and video bandwidth is 300kHz for Peak detection and Quasi-peak detection at frequency below 1GHz.
4. According to technical experiences, all spurious emission of 802.11a mode at channel 149, 157, 165 are almost the same below 1GHz, so that the channel 149 was chosen as representative in final test.
5. The data is worse case.



Power	: AC 120V	Pol/Phase	: HORIZONTAL
Test Mode	: 802.11a, CH149	Temperature	: 26 °C
Memo	:	Humidity	: 58 %

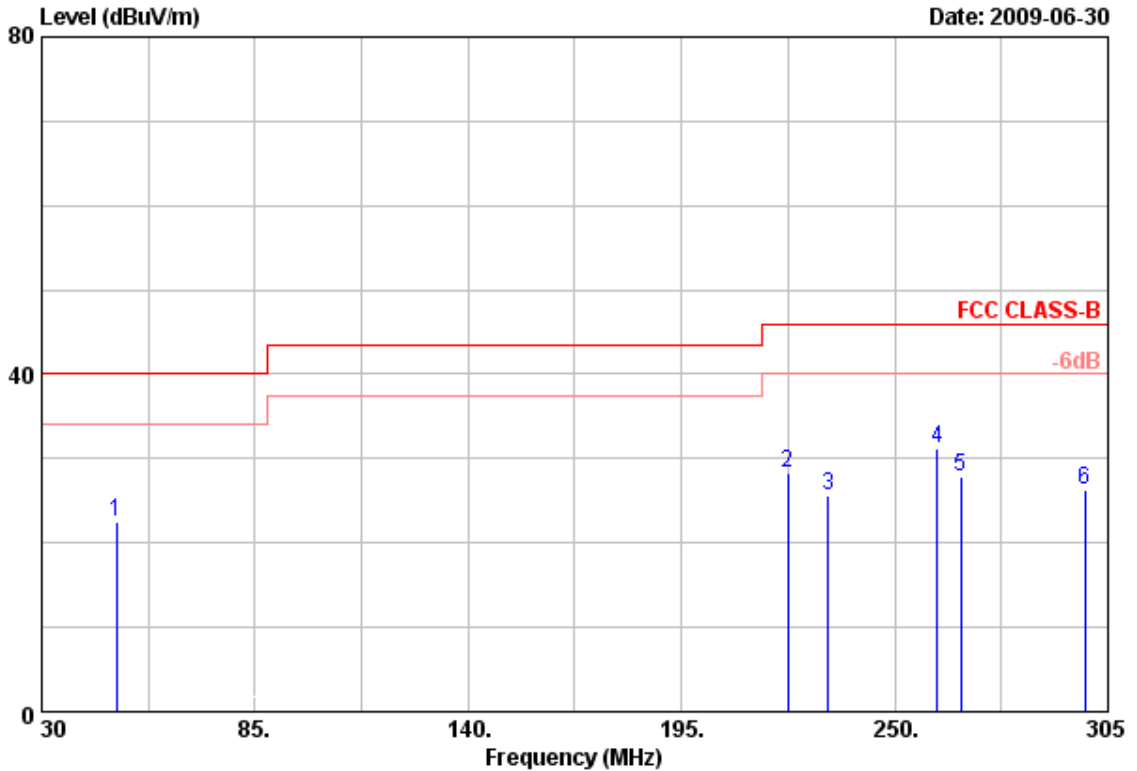

Item	Freq	Read Value	Factor	Result	Limit	Margin	Remark	Ant Pos	Tab Pos
	MHz	dBuV/m	dB	dBuV/m	dBuV/m	dB		cm	Deg
1	49.25	36.94	-14.52	22.42	40.00	-17.58	Peak	104	360
2	222.50	43.60	-15.37	28.23	46.00	-17.77	Peak	104	360
3	232.95	41.76	-16.11	25.65	46.00	-20.35	Peak	104	360
4	261.00	45.02	-13.86	31.16	46.00	-14.84	Peak	104	360
5	267.05	41.38	-13.53	27.85	46.00	-18.15	Peak	104	360
6	298.95	39.52	-13.15	26.37	46.00	-19.63	Peak	104	360

Notes:

1. Result = Read Value + Factor
2. Factor = Antenna Factor + Cable Loss - Amplifier
3. The resolution bandwidth of test receiver/spectrum analyzer is 120KHz and video bandwidth is 300kHz for Peak detection and Quasi-peak detection at frequency below 1GHz.
4. According to technical experiences, all spurious emission of 802.11a mode at channel 149, 157, 165 are almost the same below 1GHz, so that the channel 149 was chosen as representative in final test.
5. The data is worse case.



Power	: AC 120V	Pol/Phase	: HORIZONTAL
Test Mode	: 802.11a, CH149	Temperature	: 26 °C
Memo	:	Humidity	: 58 %

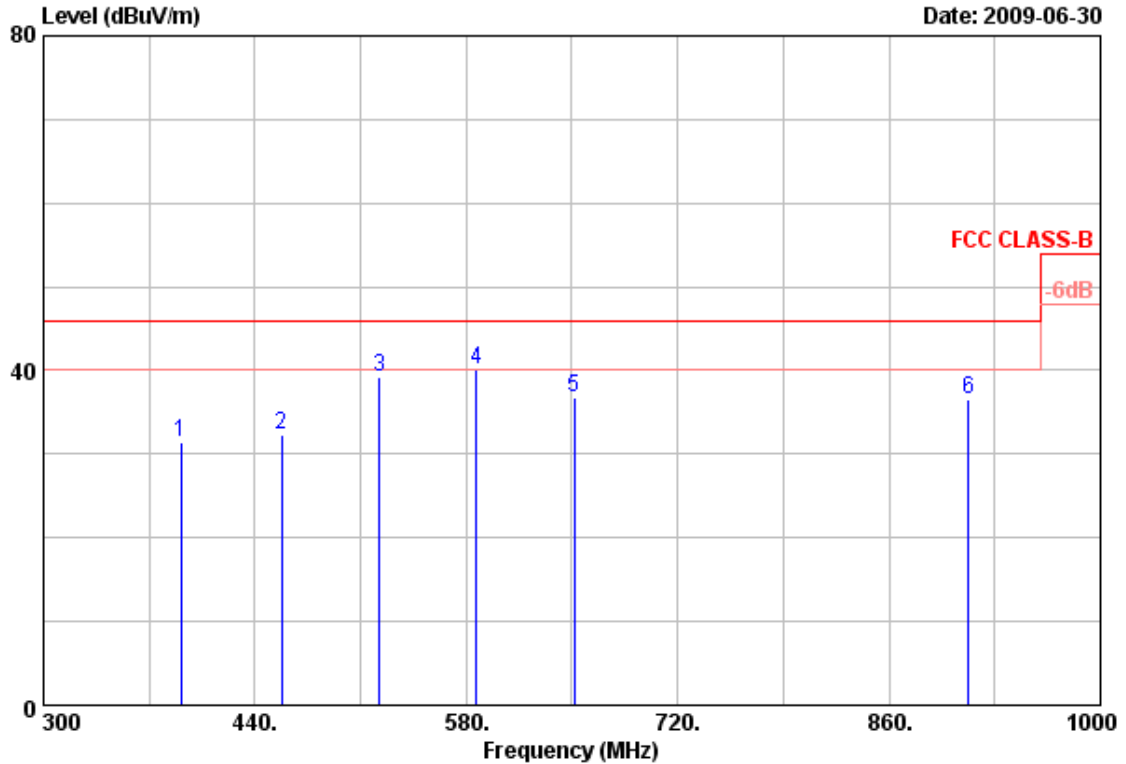

Item	Freq	Read Value	Factor	Result	Limit	Margin	Remark	Ant Pos	Tab Pos
	MHz	dBuV/m	dB	dBuV/m	dBuV/m	dB		cm	Deg
1	391.00	42.21	-10.87	31.34	46.00	-14.66	Peak	104	360
2	457.50	37.65	-5.27	32.38	46.00	-13.62	Peak	104	360
3	522.60	45.36	-6.07	39.29	46.00	-6.71	Peak	104	360
4	587.00	42.17	-2.05	40.12	46.00	-5.88	QP	104	360
5	651.40	39.11	-2.36	36.75	46.00	-9.25	Peak	104	360
6	912.50	34.24	2.35	36.59	46.00	-9.41	Peak	104	360

Notes:

1. Result = Read Value + Factor
2. Factor = Antenna Factor + Cable Loss - Amplifier
3. The resolution bandwidth of test receiver/spectrum analyzer is 120KHz and video bandwidth is 300kHz for Peak detection and Quasi-peak detection at frequency below 1GHz.
4. According to technical experiences, all spurious emission of 802.11a mode at channel 149,157,165 are almost the same below 1GHz, so that the channel 149 was chosen as representative in final test.
5. The data is worse case.



Power	: AC 120V	Pol/Phase	: VERTICAL
Test Mode	: 802.11a, CH149	Temperature	: 26 °C
Memo	:	Humidity	: 58 %

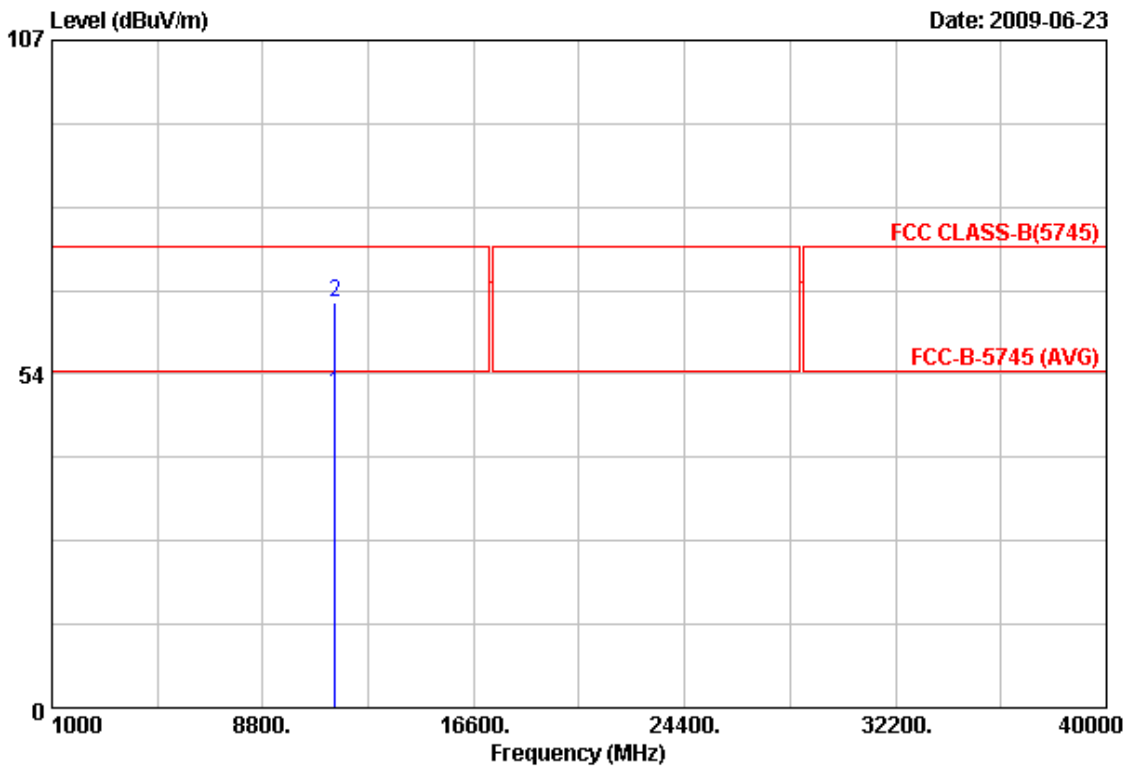

Item	Freq	Read Value	Factor	Result	Limit	Margin	Remark	Ant Pos	Tab Pos
	MHz	dBuV/m	dB	dBuV/m	dBuV/m	dB		cm	Deg
1	11489.15	31.89	18.49	50.38	54.00	-3.62	Average	103	360
2	11489.15	46.59	18.49	65.08	74.00	-8.92	Peak	103	360

Notes:

1. Result = Read Value + Factor
2. Factor = Antenna Factor + Cable Loss - Amplifier
3. The resolution bandwidth of test receiver/spectrum analyzer is 120KHz and video bandwidth is 300kHz for Peak detection and Quasi-peak detection at frequency below 1GHz.
4. The resolution bandwidth of test receiver/spectrum analyzer is 1MHz and video bandwidth is 3MHz for Peak detection at frequency above 1GHz.
5. The resolution bandwidth of test receiver/spectrum analyzer is 1MHz and video bandwidth is 10Hz for Average detection at frequency above 1GHz.
6. The other emissions is too low to be measured.



Power	: AC 120V	Pol/Phase	: HORIZONTAL
Test Mode	: 802.11a, CH149	Temperature	: 26 °C
Memo	:	Humidity	: 58 %

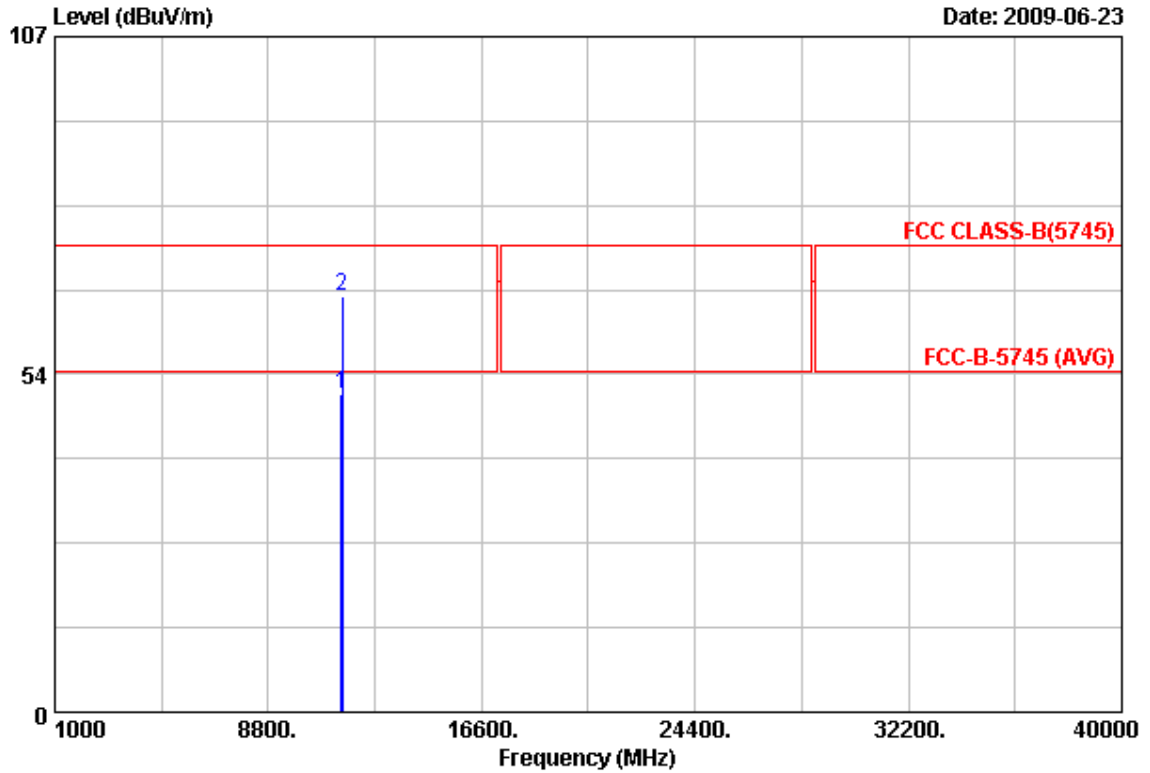

Item	Freq	Read Value	Factor	Result	Limit	Margin	Remark	Ant Pos	Tab Pos
	MHz	dBuV/m	dB	dBuV/m	dBuV/m	dB		cm	Deg
1	11489.20	31.87	18.49	50.36	54.00	-3.64	Average	103	360
2	11492.80	47.27	18.49	65.76	74.00	-8.24	Peak	103	360

Notes:

1. Result = Read Value + Factor
2. Factor = Antenna Factor + Cable Loss - Amplifier
3. The resolution bandwidth of test receiver/spectrum analyzer is 120KHz and video bandwidth is 300kHz for Peak detection and Quasi-peak detection at frequency below 1GHz.
4. The resolution bandwidth of test receiver/spectrum analyzer is 1MHz and video bandwidth is 3MHz for Peak detection at frequency above 1GHz.
5. The resolution bandwidth of test receiver/spectrum analyzer is 1MHz and video bandwidth is 10Hz for Average detection at frequency above 1GHz.
6. The other emissions is too low to be measured.



Power	: AC 120V	Pol/Phase	: VERTICAL
Test Mode	: 802.11a, CH157	Temperature	: 26 °C
Memo	:	Humidity	: 58 %

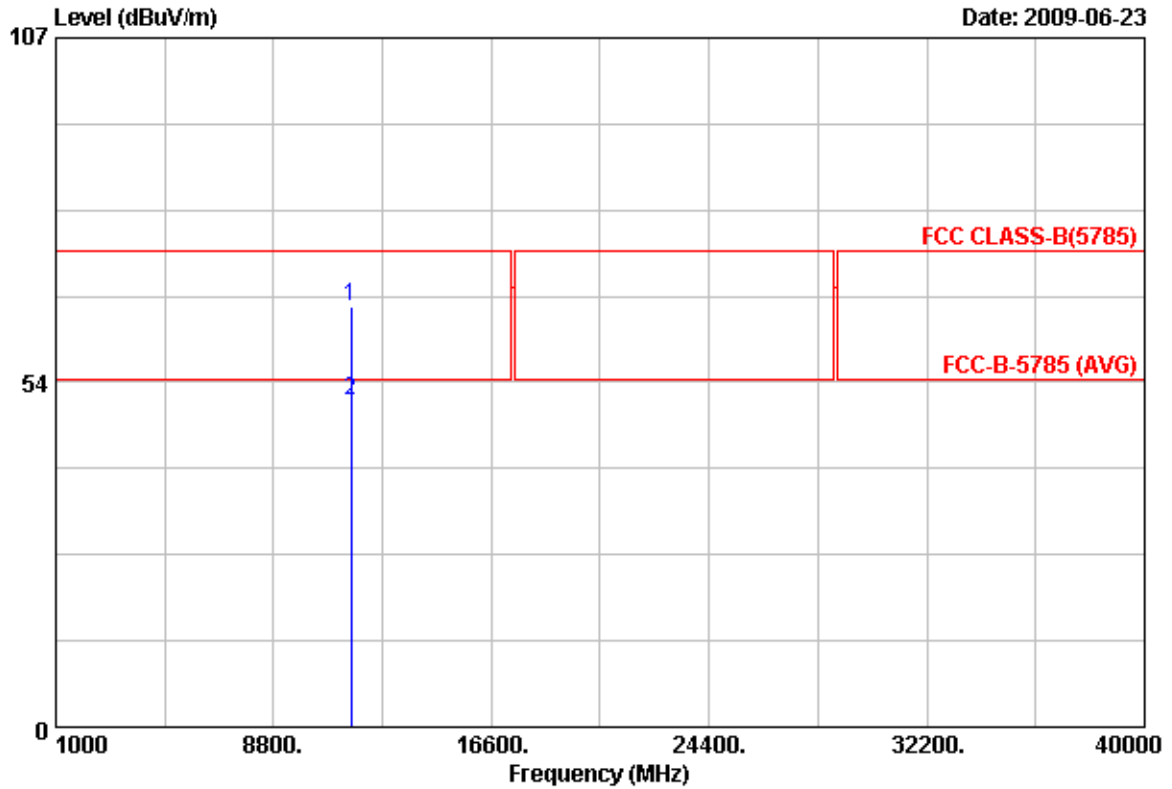

Item	Freq	Read Value	Factor	Result	Limit	Margin	Remark	Ant Pos	Tab Pos
	MHz	dBuV/m	dB	dBuV/m	dBuV/m	dB		cm	Deg
1	11567.65	46.83	18.56	65.39	74.00	-8.61	Peak	103	360
2	11572.55	32.00	18.55	50.55	54.00	-3.45	Average	103	360

Notes:

1. Result = Read Value + Factor
2. Factor = Antenna Factor + Cable Loss - Amplifier
3. The resolution bandwidth of test receiver/spectrum analyzer is 120KHz and video bandwidth is 300kHz for Peak detection and Quasi-peak detection at frequency below 1GHz.
4. The resolution bandwidth of test receiver/spectrum analyzer is 1MHz and video bandwidth is 3MHz for Peak detection at frequency above 1GHz.
5. The resolution bandwidth of test receiver/spectrum analyzer is 1MHz and video bandwidth is 10Hz for Average detection at frequency above 1GHz.
6. The other emissions is too low to be measured.



Power	: AC 120V	Pol/Phase	: HORIZONTAL
Test Mode	: 802.11a, CH157	Temperature	: 26 °C
Memo	:	Humidity	: 58 %

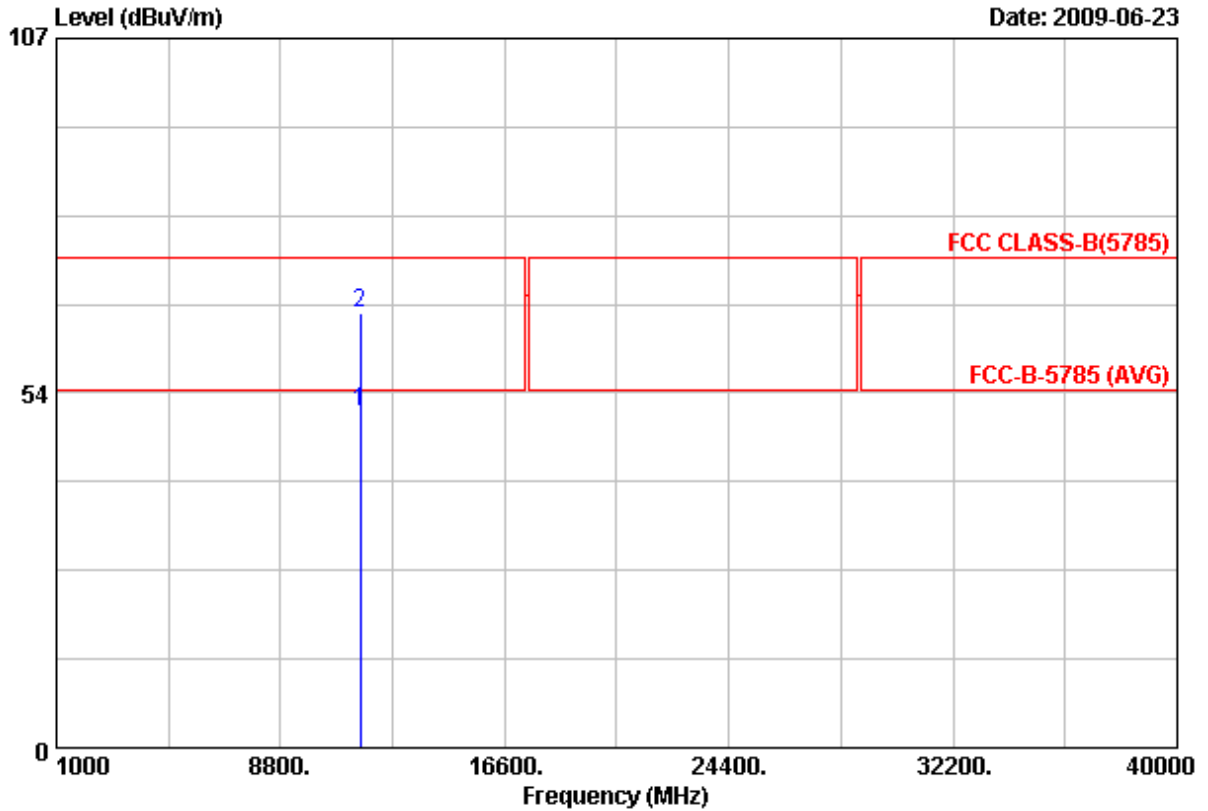

Item	Freq	Read Value	Factor	Result	Limit	Margin	Remark	Ant Pos	Tab Pos
	MHz	dBuV/m	dB	dBuV/m	dBuV/m	dB		cm	Deg
1	11570.20	32.02	18.55	50.57	54.00	-3.43	Average	103	360
2	11572.00	46.98	18.55	65.53	74.00	-8.47	Peak	103	360

Notes:

1. Result = Read Value + Factor
2. Factor = Antenna Factor + Cable Loss - Amplifier
3. The resolution bandwidth of test receiver/spectrum analyzer is 120KHz and video bandwidth is 300kHz for Peak detection and Quasi-peak detection at frequency below 1GHz.
4. The resolution bandwidth of test receiver/spectrum analyzer is 1MHz and video bandwidth is 3MHz for Peak detection at frequency above 1GHz.
5. The resolution bandwidth of test receiver/spectrum analyzer is 1MHz and video bandwidth is 10Hz for Average detection at frequency above 1GHz.
6. The other emissions is too low to be measured.



Power	: AC 120V	Pol/Phase	: VERTICAL
Test Mode	: 802.11a, CH165	Temperature	: 26 °C
Memo	:	Humidity	: 58 %

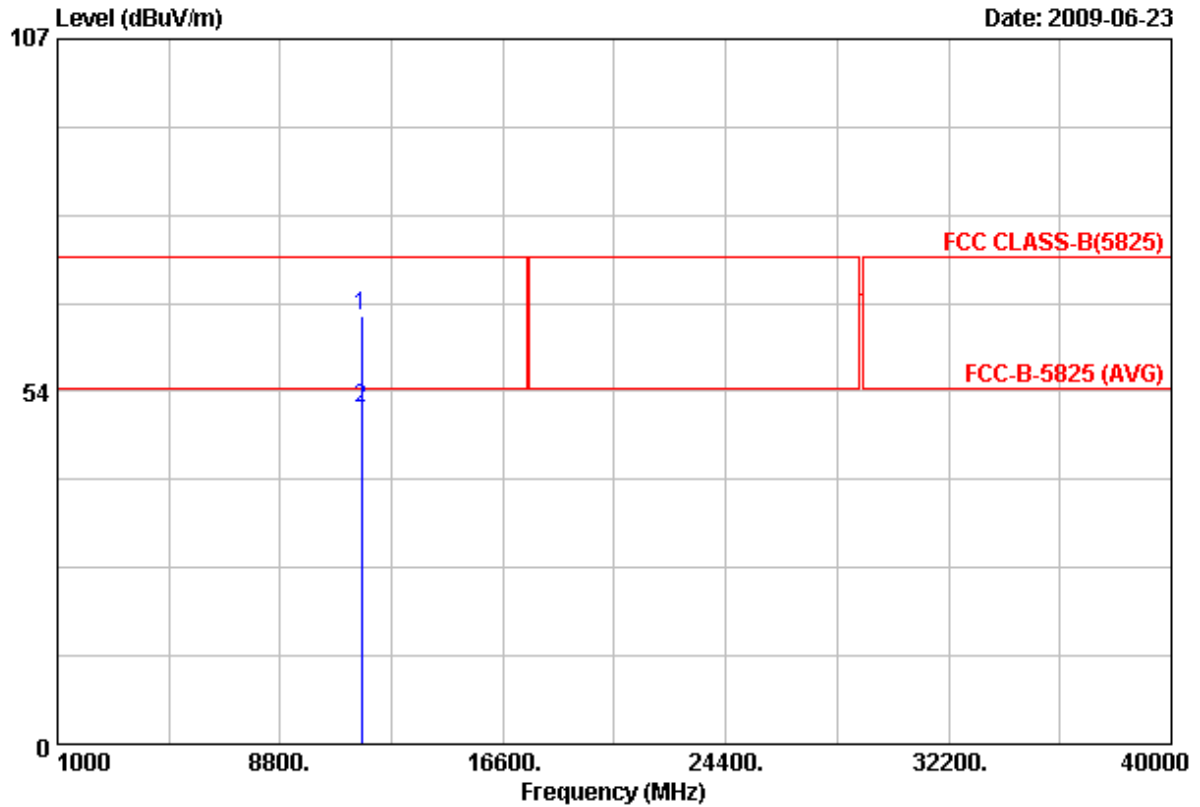

Item	Freq	Read Value	Factor	Result	Limit	Margin	Remark	Ant Pos	Tab Pos
	MHz	dBuV/m	dB	dBuV/m	dBuV/m	dB		cm	Deg
1	11648.40	46.49	18.62	65.11	74.00	-8.89	Peak	103	360
2	11649.60	32.29	18.62	50.91	54.00	-3.09	Average	103	360

Notes:

1. Result = Read Value + Factor
2. Factor = Antenna Factor + Cable Loss - Amplifier
3. The resolution bandwidth of test receiver/spectrum analyzer is 120KHz and video bandwidth is 300kHz for Peak detection and Quasi-peak detection at frequency below 1GHz.
4. The resolution bandwidth of test receiver/spectrum analyzer is 1MHz and video bandwidth is 3MHz for Peak detection at frequency above 1GHz.
5. The resolution bandwidth of test receiver/spectrum analyzer is 1MHz and video bandwidth is 10Hz for Average detection at frequency above 1GHz.
6. The other emissions is too low to be measured.



Power	: AC 120V	Pol/Phase	: HORIZONTAL
Test Mode	: 802.11a, CH165	Temperature	: 26 °C
Memo	:	Humidity	: 58 %

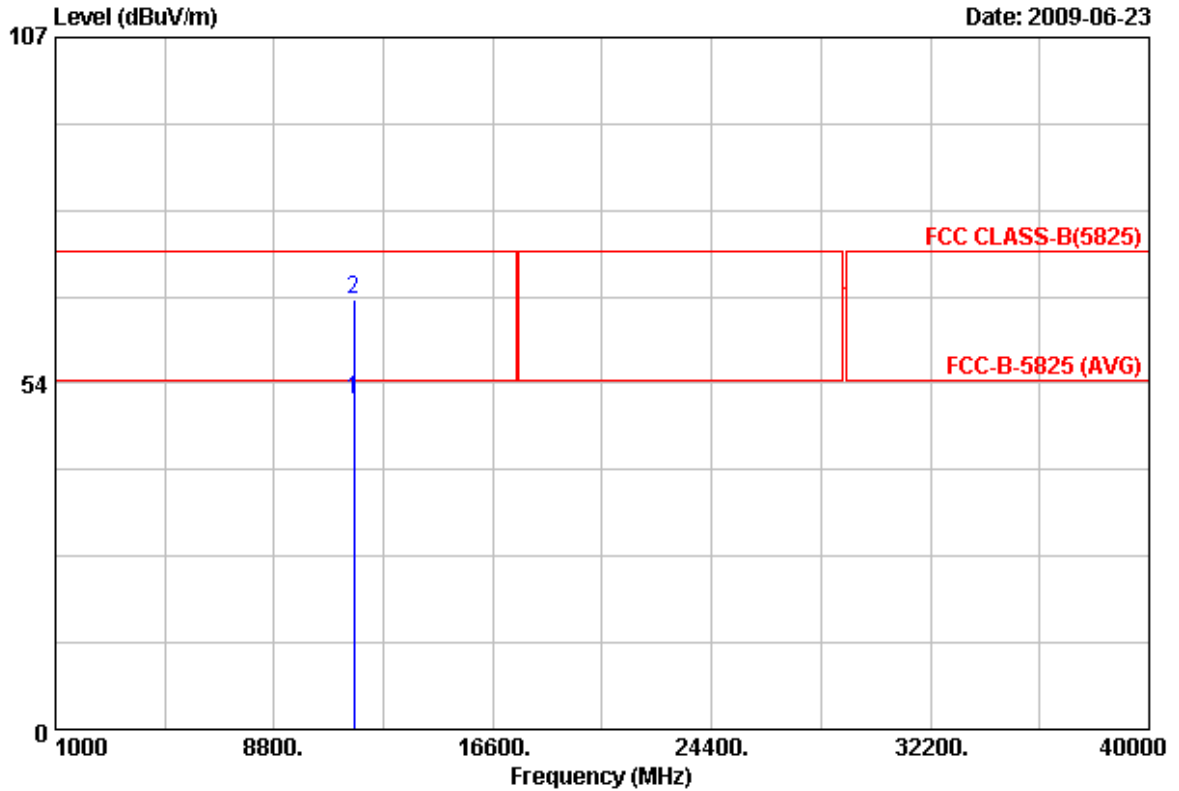

Item	Freq	Read Value	Factor	Result	Limit	Margin	Remark	Ant Pos	Tab Pos
	MHz	dBuV/m	dB	dBuV/m	dBuV/m	dB		cm	Deg
1	11652.70	32.26	18.62	50.88	54.00	-3.12	Average	103	360
2	11654.40	47.77	18.62	66.39	74.00	-7.61	Peak	103	360

Notes:

1. Result = Read Value + Factor
2. Factor = Antenna Factor + Cable Loss - Amplifier
3. The resolution bandwidth of test receiver/spectrum analyzer is 120KHz and video bandwidth is 300kHz for Peak detection and Quasi-peak detection at frequency below 1GHz.
4. The resolution bandwidth of test receiver/spectrum analyzer is 1MHz and video bandwidth is 3MHz for Peak detection at frequency above 1GHz.
5. The resolution bandwidth of test receiver/spectrum analyzer is 1MHz and video bandwidth is 10Hz for Average detection at frequency above 1GHz.
6. The other emissions is too low to be measured.



Power	: AC 120V	Pol/Phase	: VERTICAL
Test Mode	: 802.11an HT20, CH149	Temperature	: 26 °C
Memo	:	Humidity	: 58 %

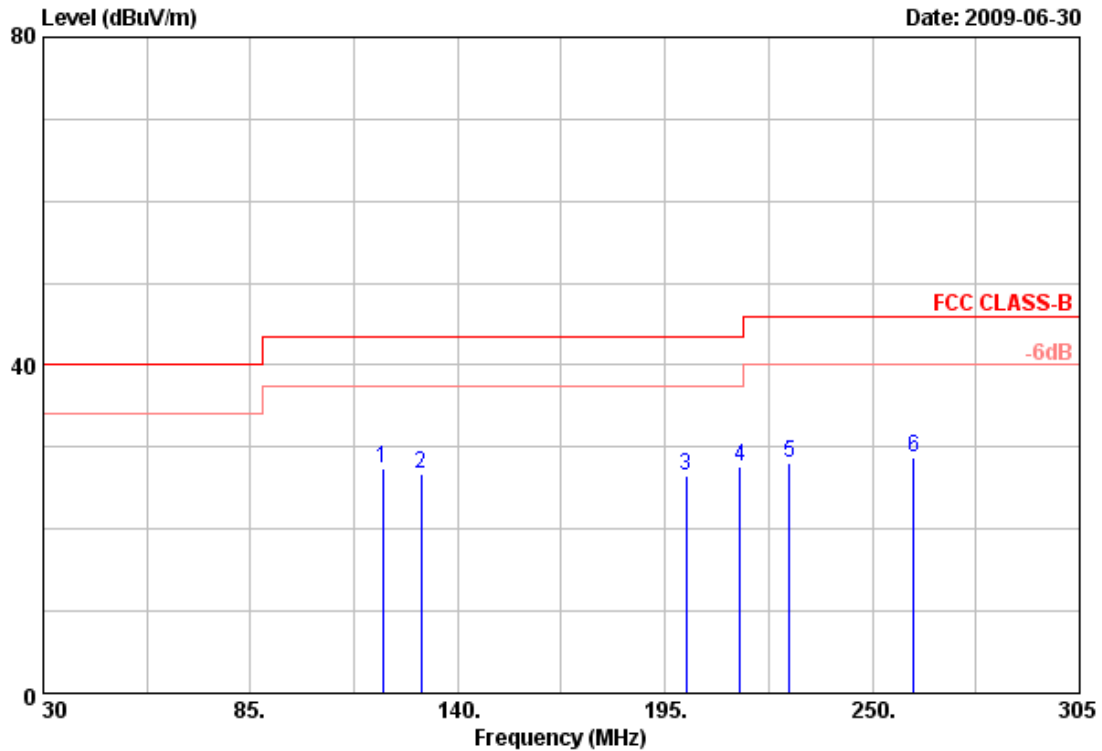

Item	Freq	Read Value	Factor	Result	Limit	Margin	Remark	Ant Pos	Tab Pos
	MHz	dBuV/m	dB	dBuV/m	dBuV/m	dB		cm	Deg
1	120.20	37.63	-10.19	27.44	43.50	-16.06	Peak	104	0
2	130.38	35.68	-8.84	26.84	43.50	-16.66	Peak	104	0
3	200.50	35.88	-9.47	26.41	43.50	-17.09	Peak	104	0
4	214.80	39.09	-11.38	27.71	43.50	-15.79	Peak	104	0
5	228.00	39.08	-11.02	28.06	46.00	-17.94	Peak	104	0
6	261.00	40.85	-12.03	28.82	46.00	-17.18	Peak	104	0

Notes:

1. Result = Read Value + Factor
2. Factor = Antenna Factor + Cable Loss - Amplifier
3. The resolution bandwidth of test receiver/spectrum analyzer is 120KHz and video bandwidth is 300kHz for Peak detection and Quasi-peak detection at frequency below 1GHz.
4. According to technical experiences, all spurious emission of 802.11an HT20 mode at channel 149, 157, 165 are almost the same below 1GHz, so that the channel 149 was chosen as representative in final test.
5. The data is worse case.



Power	: AC 120V	Pol/Phase	: VERTICAL
Test Mode	: 802.11an HT20, CH149	Temperature	: 26 °C
Memo	:	Humidity	: 58 %

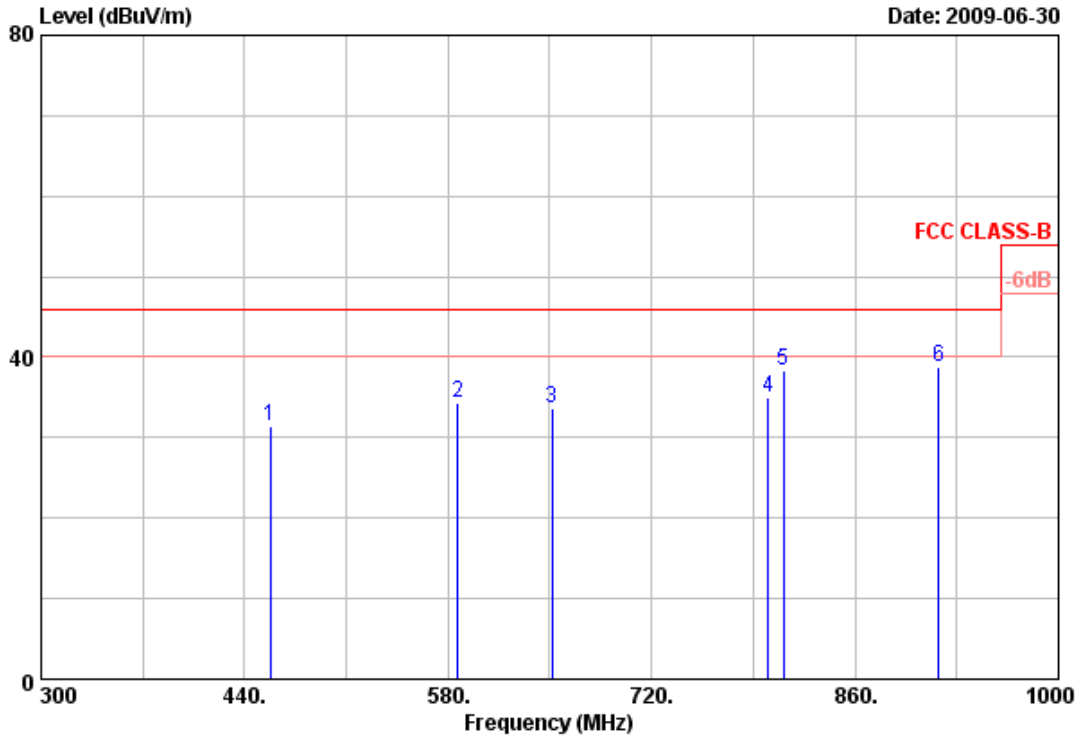

Item	Freq	Read Value	Factor	Result	Limit	Margin	Remark	Ant Pos	Tab Pos
	MHz	dBUV/m	dB	dBUV/m	dBUV/m	dB		cm	Deg
1	457.50	39.47	-8.05	31.42	46.00	-14.58	Peak	104	0
2	587.00	39.12	-4.86	34.26	46.00	-11.74	Peak	104	0
3	651.40	38.98	-5.31	33.67	46.00	-12.33	Peak	104	0
4	800.50	36.03	-1.09	34.94	46.00	-11.06	Peak	104	0
5	811.00	39.40	-1.00	38.40	46.00	-7.60	Peak	104	0
6	917.40	34.61	4.12	38.73	46.00	-7.27	Peak	104	0

Notes:

1. Result = Read Value + Factor
2. Factor = Antenna Factor + Cable Loss - Amplifier
3. The resolution bandwidth of test receiver/spectrum analyzer is 120KHz and video bandwidth is 300kHz for Peak detection and Quasi-peak detection at frequency below 1GHz.
4. According to technical experiences, all spurious emission of 802.11an HT20 mode at channel 149,157,165 are almost the same below 1GHz, so that the channel 149 was chosen as representative in final test.
5. The data is worse case.



Power	: AC 120V	Pol/Phase	: HORIZONTAL
Test Mode	: 802.11an HT20, CH149	Temperature	: 26 °C
Memo	:	Humidity	: 58 %

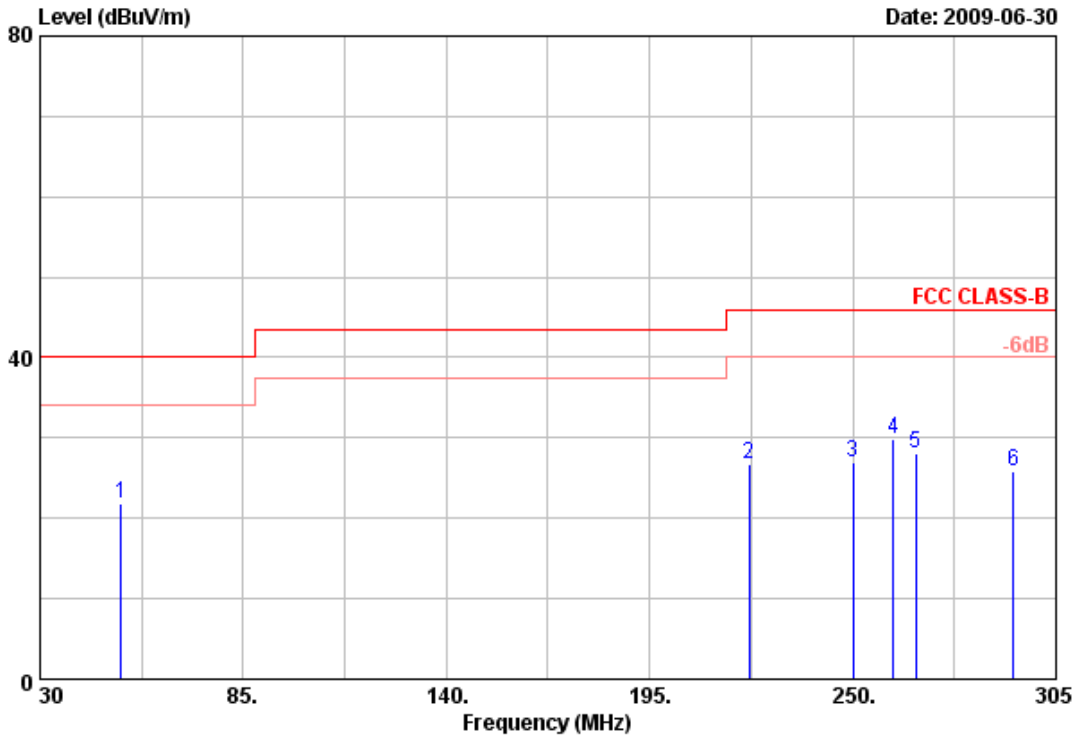

Item	Freq	Read Value	Factor	Result	Limit	Margin	Remark	Ant Pos	Tab Pos
	MHz	dBuV/m	dB	dBuV/m	dBuV/m	dB		cm	Deg
1	52.00	37.14	-15.24	21.90	40.00	-18.10	Peak	104	360
2	221.95	42.22	-15.40	26.82	46.00	-19.18	Peak	104	360
3	250.00	42.24	-15.28	26.96	46.00	-19.04	Peak	104	360
4	261.00	43.82	-13.86	29.96	46.00	-16.04	Peak	104	360
5	267.05	41.62	-13.53	28.09	46.00	-17.91	Peak	104	360
6	293.45	39.54	-13.62	25.92	46.00	-20.08	Peak	104	360

Notes:

1. Result = Read Value + Factor
2. Factor = Antenna Factor + Cable Loss - Amplifier
3. The resolution bandwidth of test receiver/spectrum analyzer is 120KHz and video bandwidth is 300KHz for Peak detection and Quasi-peak detection at frequency below 1GHz.
4. According to technical experiences, all spurious emission of 802.11an HT20 mode at channel 149, 157, 165 are almost the same below 1GHz, so that the channel 149 was chosen as representative in final test.
5. The data is worse case.



Power	: AC 120V	Pol/Phase	: HORIZONTAL
Test Mode	: 802.11an HT20, CH149	Temperature	: 26 °C
Memo	:	Humidity	: 58 %

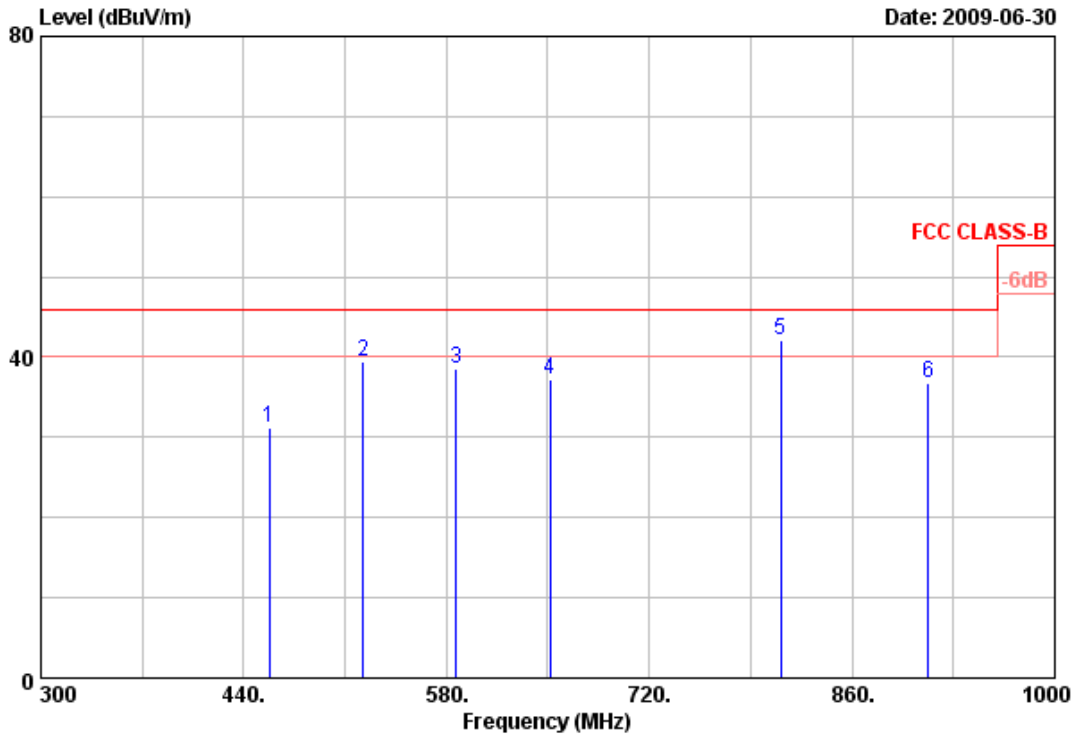

Item	Freq	Read Value	Factor	Result	Limit	Margin	Remark	Ant Pos	Tab Pos
	MHz	dBuV/m	dB	dBuV/m	dBuV/m	dB		cm	Deg
1	457.50	36.50	-5.27	31.23	46.00	-14.77	Peak	104	360
2	522.60	45.41	-6.07	39.34	46.00	-6.66	Peak	104	360
3	587.00	40.65	-2.05	38.60	46.00	-7.40	Peak	104	360
4	651.40	39.56	-2.36	37.20	46.00	-8.80	Peak	104	360
5	811.00	42.32	-0.31	42.01	46.00	-3.99	QP	104	360
6	912.50	34.32	2.35	36.67	46.00	-9.33	Peak	104	360

Notes:

1. Result = Read Value + Factor
2. Factor = Antenna Factor + Cable Loss - Amplifier
3. The resolution bandwidth of test receiver/spectrum analyzer is 120KHz and video bandwidth is 300kHz for Peak detection and Quasi-peak detection at frequency below 1GHz.
4. According to technical experiences, all spurious emission of 802.11an HT20 mode at channel 149, 157, 165 are almost the same below 1GHz, so that the channel 149 was chosen as representative in final test.
5. The data is worse case.



Power	: AC 120V	Pol/Phase	: VERTICAL
Test Mode	: 802.11an HT20, CH149	Temperature	: 26 °C
Memo	:	Humidity	: 58 %

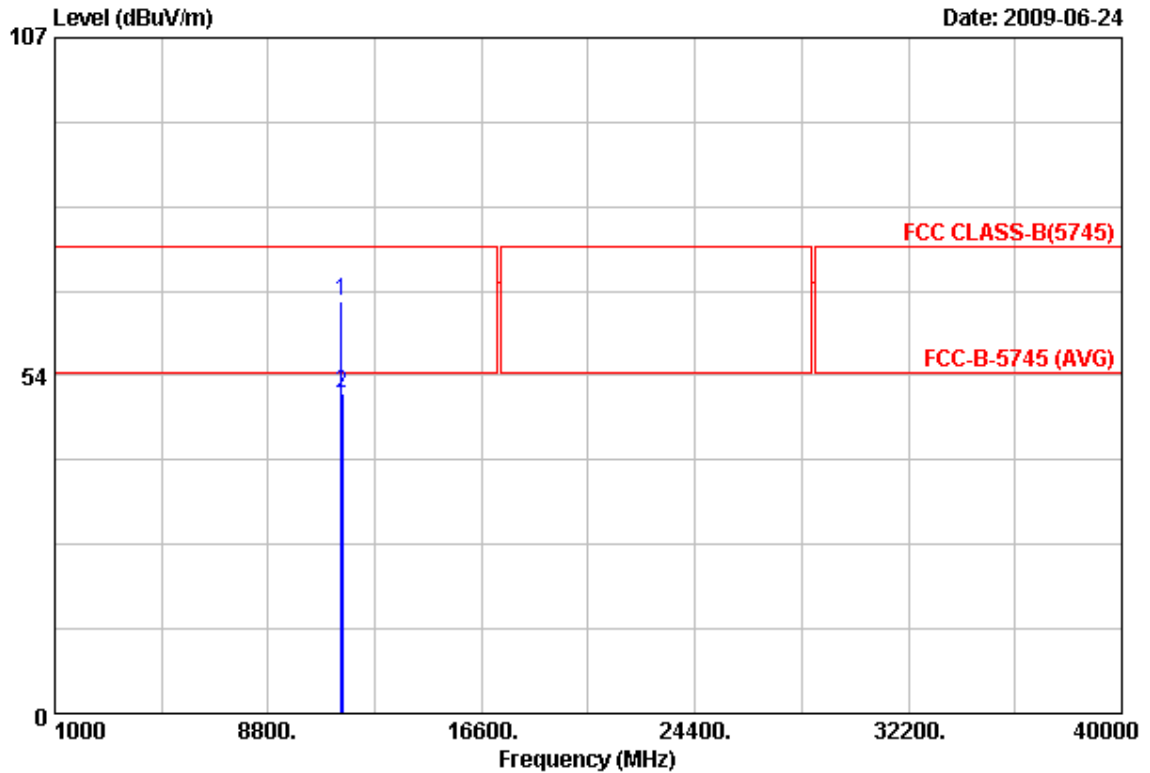

Item	Freq	Read Value	Factor	Result	Limit	Margin	Remark	Ant Pos	Tab Pos
	MHz	dBuV/m	dB	dBuV/m	dBuV/m	dB		cm	Deg
1	11488.40	46.69	18.49	65.18	74.00	-8.82	Peak	103	0
2	11489.45	32.05	18.49	50.54	54.00	-3.46	Average	103	0

Notes:

1. Result = Read Value + Factor
2. Factor = Antenna Factor + Cable Loss - Amplifier
3. The resolution bandwidth of test receiver/spectrum analyzer is 120KHz and video bandwidth is 300kHz for Peak detection and Quasi-peak detection at frequency below 1GHz.
4. The resolution bandwidth of test receiver/spectrum analyzer is 1MHz and video bandwidth is 3MHz for Peak detection at frequency above 1GHz.
5. The resolution bandwidth of test receiver/spectrum analyzer is 1MHz and video bandwidth is 10Hz for Average detection at frequency above 1GHz.
6. The other emissions is too low to be measured.



Power	: AC 120V	Pol/Phase	: HORIZONTAL
Test Mode	: 802.11an HT20, CH149	Temperature	: 26 °C
Memo	:	Humidity	: 58 %

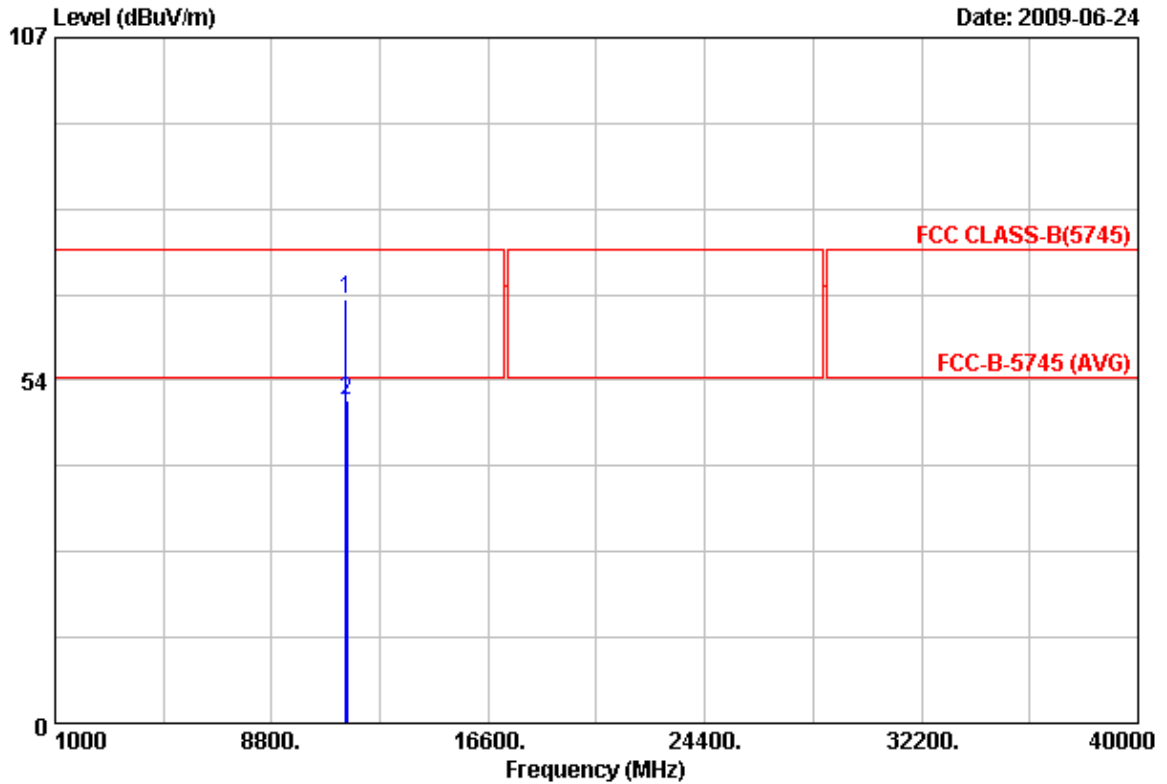

Item	Freq	Read Value	Factor	Result	Limit	Margin	Remark	Ant Pos	Tab Pos
	MHz	dBuV/m	dB	dBuV/m	dBuV/m	dB		cm	Deg
1	11486.30	47.69	18.49	66.18	74.00	-7.82	Peak	103	0
2	11492.20	32.01	18.49	50.50	54.00	-3.50	Average	103	0

Notes:

1. Result = Read Value + Factor
2. Factor = Antenna Factor + Cable Loss - Amplifier
3. The resolution bandwidth of test receiver/spectrum analyzer is 120KHz and video bandwidth is 300kHz for Peak detection and Quasi-peak detection at frequency below 1GHz.
4. The resolution bandwidth of test receiver/spectrum analyzer is 1MHz and video bandwidth is 3MHz for Peak detection at frequency above 1GHz.
5. The resolution bandwidth of test receiver/spectrum analyzer is 1MHz and video bandwidth is 10Hz for Average detection at frequency above 1GHz.
6. The other emissions is too low to be measured.



Power	: AC 120V	Pol/Phase	: VERTICAL
Test Mode	: 802.11an HT20, CH157	Temperature	: 26 °C
Memo	:	Humidity	: 58 %

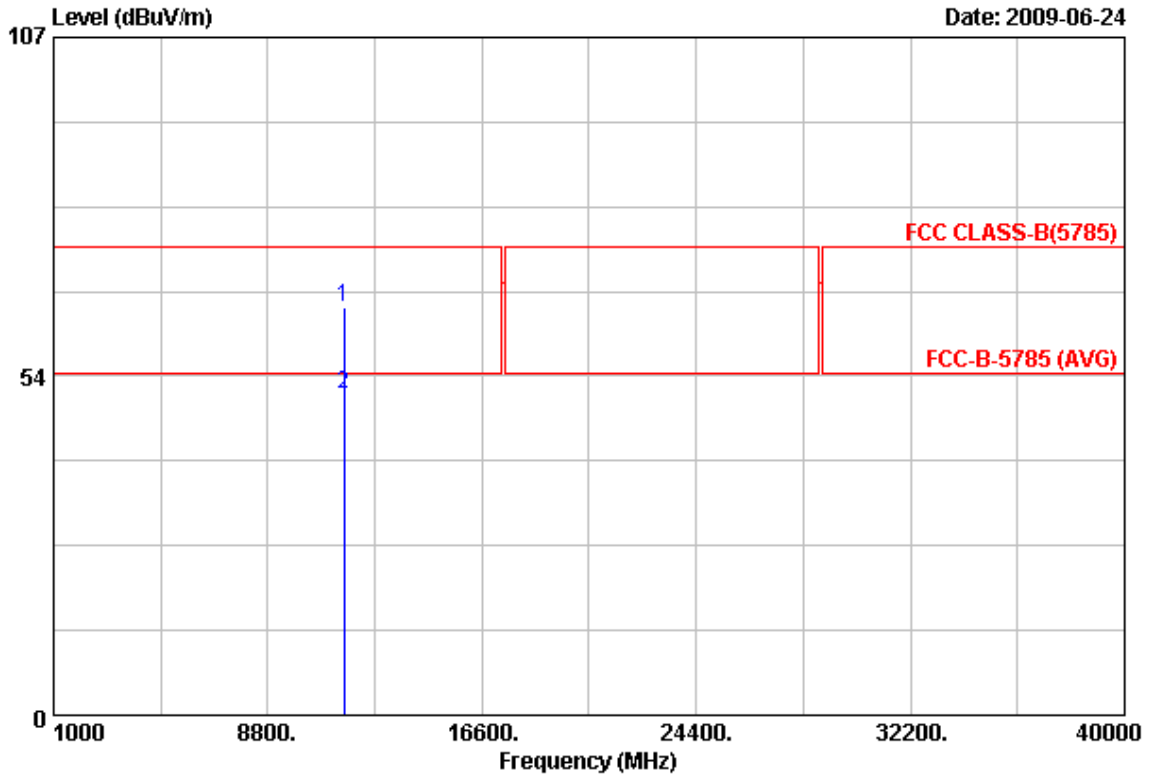

Item	Freq	Read Value	Factor	Result	Limit	Margin	Remark	Ant Pos	Tab Pos
	MHz	dBuV/m	dB	dBuV/m	dBuV/m	dB		cm	Deg
1	11568.60	45.77	18.56	64.33	74.00	-9.67	Peak	103	360
2	11568.80	32.15	18.55	50.70	54.00	-3.30	Average	103	360

Notes:

1. Result = Read Value + Factor
2. Factor = Antenna Factor + Cable Loss - Amplifier
3. The resolution bandwidth of test receiver/spectrum analyzer is 120KHz and video bandwidth is 300kHz for Peak detection and Quasi-peak detection at frequency below 1GHz.
4. The resolution bandwidth of test receiver/spectrum analyzer is 1MHz and video bandwidth is 3MHz for Peak detection at frequency above 1GHz.
5. The resolution bandwidth of test receiver/spectrum analyzer is 1MHz and video bandwidth is 10Hz for Average detection at frequency above 1GHz.
6. The other emissions is too low to be measured.



Power	: AC 120V	Pol/Phase	: HORIZONTAL
Test Mode	: 802.11an HT20, CH157	Temperature	: 26 °C
Memo	:	Humidity	: 58 %

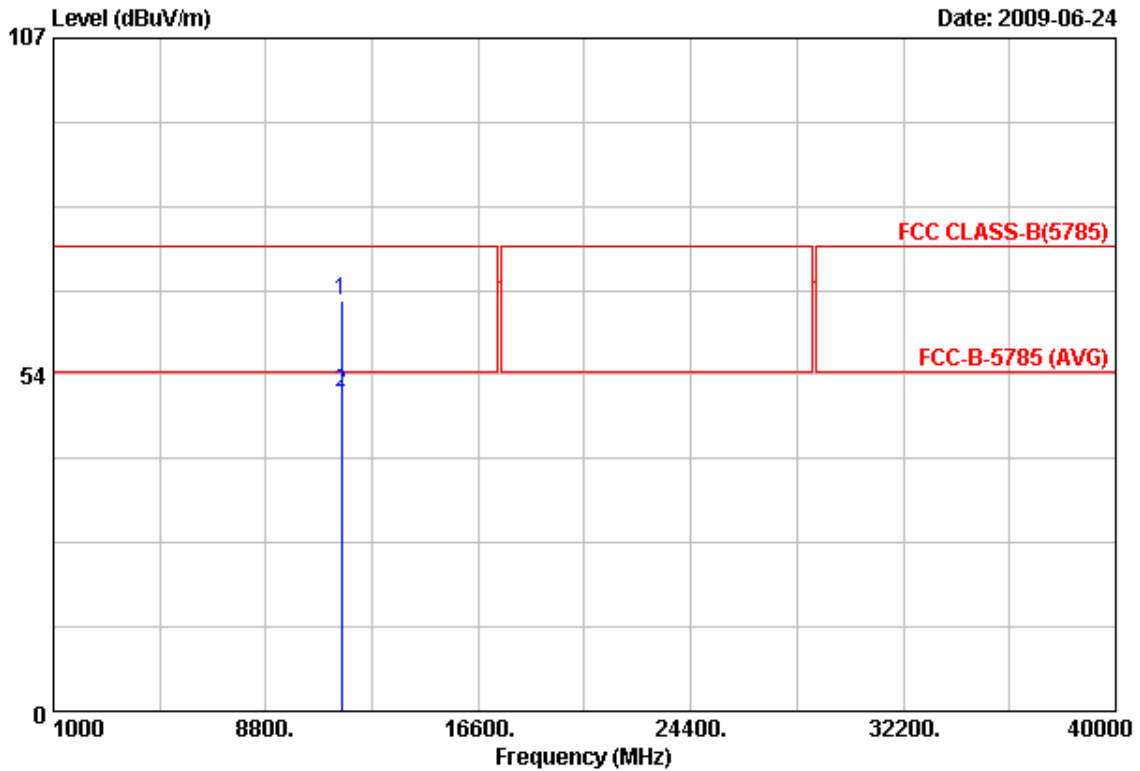

Item	Freq	Read Value	Factor	Result	Limit	Margin	Remark	Ant Pos	Tab Pos
	MHz	dBuV/m	dB	dBuV/m	dBuV/m	dB		cm	Deg
1	11569.15	46.66	18.55	65.21	74.00	-8.79	Peak	103	360
2	11570.90	32.04	18.55	50.59	54.00	-3.41	Average	103	360

Notes:

1. Result = Read Value + Factor
2. Factor = Antenna Factor + Cable Loss - Amplifier
3. The resolution bandwidth of test receiver/spectrum analyzer is 120KHz and video bandwidth is 300kHz for Peak detection and Quasi-peak detection at frequency below 1GHz.
4. The resolution bandwidth of test receiver/spectrum analyzer is 1MHz and video bandwidth is 3MHz for Peak detection at frequency above 1GHz.
5. The resolution bandwidth of test receiver/spectrum analyzer is 1MHz and video bandwidth is 10Hz for Average detection at frequency above 1GHz.
6. The other emissions is too low to be measured.



Power	: AC 120V	Pol/Phase	: VERTICAL
Test Mode	: 802.11an HT20, CH165	Temperature	: 26 °C
Memo	:	Humidity	: 58 %

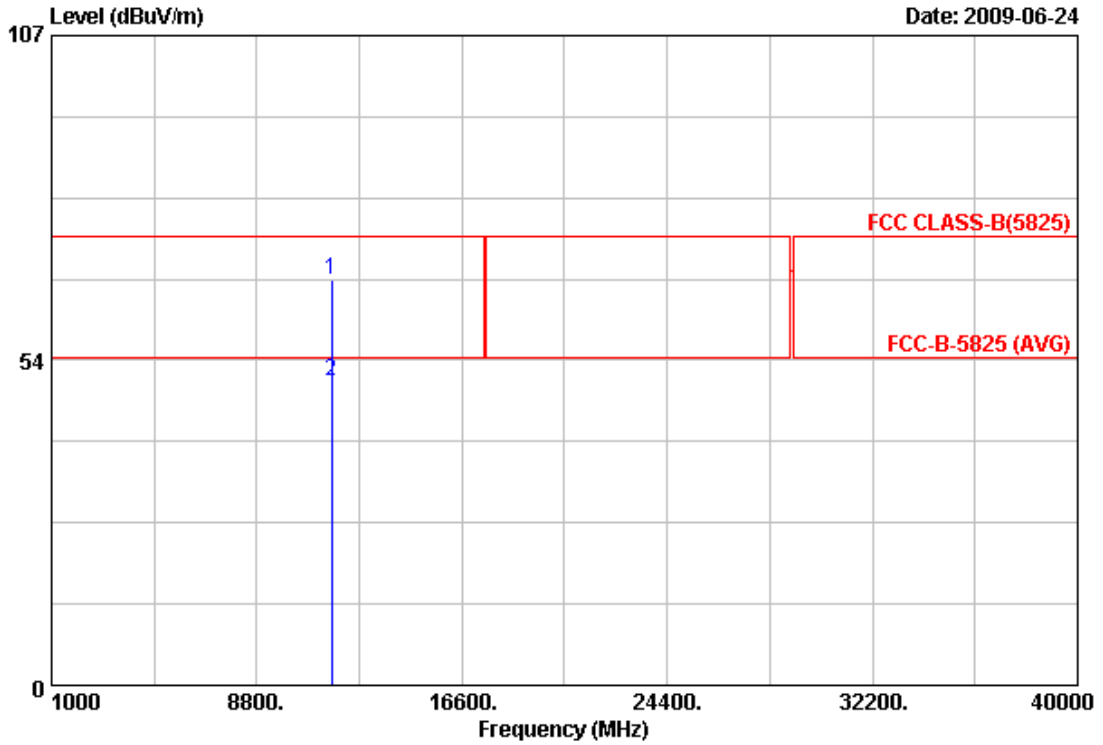

Item	Freq	Read Value	Factor	Result	Limit	Margin	Remark	Ant Pos	Tab Pos
	MHz	dBuV/m	dB	dBuV/m	dBuV/m	dB		cm	Deg
1	11648.35	48.12	18.62	66.74	74.00	-7.26	Peak	103	360
2	11648.70	31.52	18.62	50.14	54.00	-3.86	Average	103	360

Notes:

1. Result = Read Value + Factor
2. Factor = Antenna Factor + Cable Loss - Amplifier
3. The resolution bandwidth of test receiver/spectrum analyzer is 120KHz and video bandwidth is 300kHz for Peak detection and Quasi-peak detection at frequency below 1GHz.
4. The resolution bandwidth of test receiver/spectrum analyzer is 1MHz and video bandwidth is 3MHz for Peak detection at frequency above 1GHz.
5. The resolution bandwidth of test receiver/spectrum analyzer is 1MHz and video bandwidth is 10Hz for Average detection at frequency above 1GHz.
6. The other emissions is too low to be measured.



Power	: AC 120V	Pol/Phase	: HORIZONTAL
Test Mode	: 802.11an HT20, CH165	Temperature	: 26 °C
Memo	:	Humidity	: 58 %

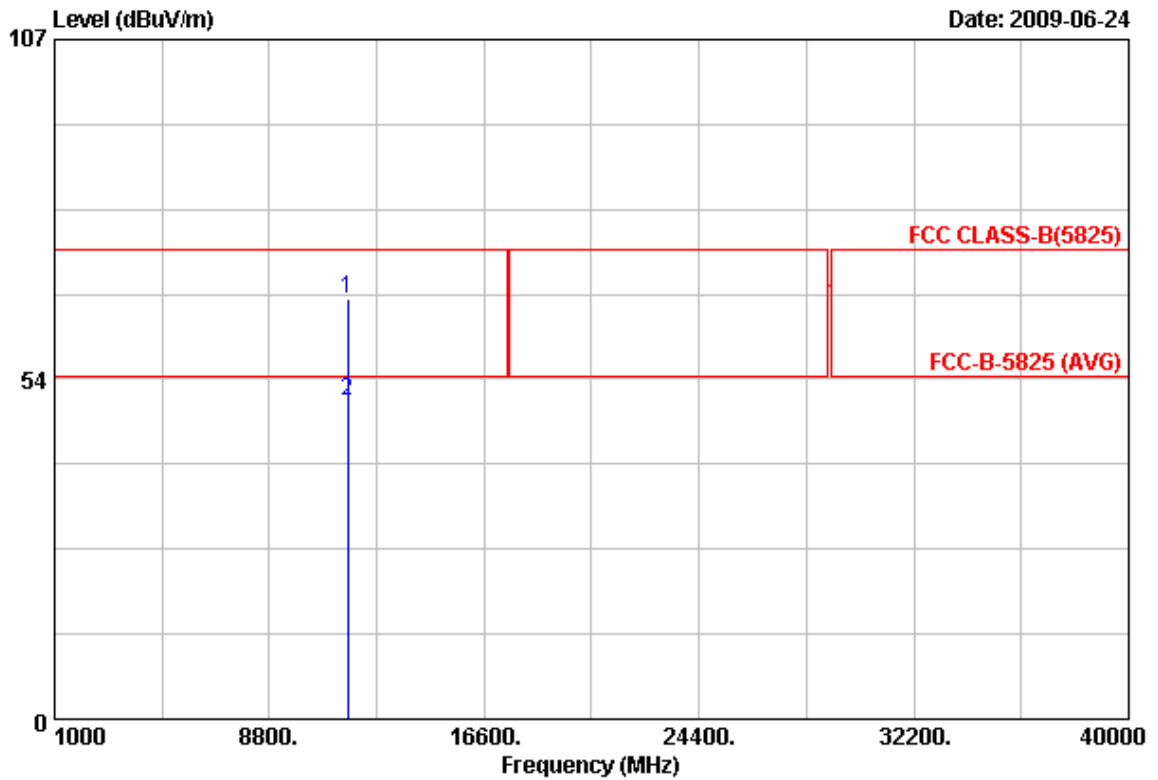

Item	Freq	Read Value	Factor	Result	Limit	Margin	Remark	Ant Pos	Tab Pos
	MHz	dBuV/m	dB	dBuV/m	dBuV/m	dB		cm	Deg
1	11647.00	47.50	18.62	66.12	74.00	-7.88	Peak	103	360
2	11653.40	31.50	18.62	50.12	54.00	-3.88	Average	103	360

Notes:

1. Result = Read Value + Factor
2. Factor = Antenna Factor + Cable Loss - Amplifier
3. The resolution bandwidth of test receiver/spectrum analyzer is 120KHz and video bandwidth is 300kHz for Peak detection and Quasi-peak detection at frequency below 1GHz.
4. The resolution bandwidth of test receiver/spectrum analyzer is 1MHz and video bandwidth is 3MHz for Peak detection at frequency above 1GHz.
5. The resolution bandwidth of test receiver/spectrum analyzer is 1MHz and video bandwidth is 10Hz for Average detection at frequency above 1GHz.
6. The other emissions is too low to be measured.



Power	: AC 120V	Pol/Phase	: VERTICAL
Test Mode	: 802.11an HT40, CH151	Temperature	: 26 °C
Memo	:	Humidity	: 58 %

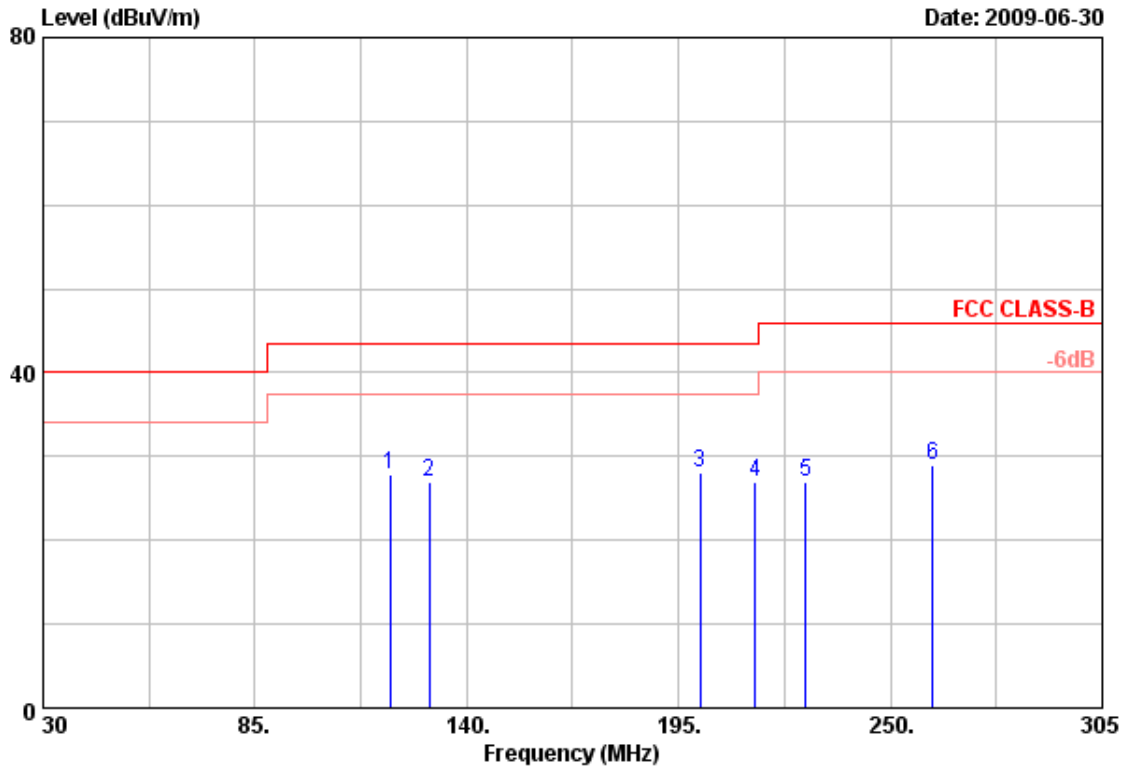

Item	Freq	Read Value	Factor	Result	Limit	Margin	Remark	Ant Pos	Tab Pos
	MHz	dBuV/m	dB	dBuV/m	dBuV/m	dB		cm	Deg
1	120.20	38.08	-10.19	27.89	43.50	-15.61	Peak	104	0
2	130.38	35.81	-8.84	26.97	43.50	-16.53	Peak	104	0
3	200.50	37.45	-9.47	27.98	43.50	-15.52	Peak	104	0
4	214.80	38.42	-11.38	27.04	43.50	-16.46	Peak	104	0
5	228.00	38.08	-11.02	27.06	46.00	-18.94	Peak	104	0
6	261.00	40.91	-12.03	28.88	46.00	-17.12	Peak	104	0

Notes:

1. Result = Read Value + Factor
2. Factor = Antenna Factor + Cable Loss - Amplifier
3. The resolution bandwidth of test receiver/spectrum analyzer is 120KHz and video bandwidth is 300kHz for Peak detection and Quasi-peak detection at frequency below 1GHz.
4. According to technical experiences, all spurious emission of 802.11an mode at channel 151,155,159 are almost the same below 1GHz, so that the channel 151 was chosen as representative in final test.
5. The data is worse case.



Power	: AC 120V	Pol/Phase	: VERTICAL
Test Mode	: 802.11an HT40, CH151	Temperature	: 26 °C
Memo	:	Humidity	: 58 %

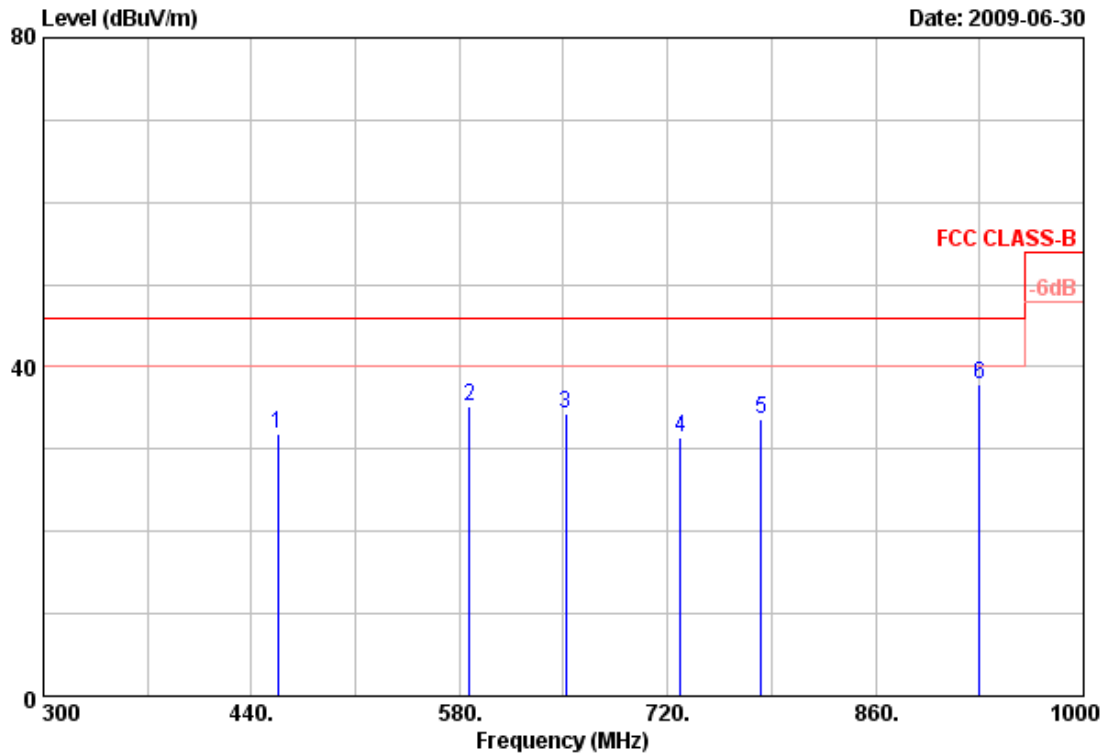

Item	Freq	Read Value	Factor	Result	Limit	Margin	Remark	Ant Pos	Tab Pos
	MHz	dBuV/m	dB	dBuV/m	dBuV/m	dB		cm	Deg
1	457.50	39.91	-8.05	31.86	46.00	-14.14	Peak	104	0
2	587.00	39.97	-4.86	35.11	46.00	-10.89	Peak	104	0
3	651.40	39.63	-5.31	34.32	46.00	-11.68	Peak	104	0
4	728.40	32.26	-0.73	31.53	46.00	-14.47	Peak	104	0
5	783.00	36.05	-2.44	33.61	46.00	-12.39	Peak	104	0
6	930.00	32.96	4.99	37.95	46.00	-8.05	Peak	104	0

Notes:

1. Result = Read Value + Factor
2. Factor = Antenna Factor + Cable Loss - Amplifier
3. The resolution bandwidth of test receiver/spectrum analyzer is 120KHz and video bandwidth is 300kHz for Peak detection and Quasi-peak detection at frequency below 1GHz.
4. According to technical experiences, all spurious emission of 802.11an mode at channel 151,155,159 are almost the same below 1GHz, so that the channel 151 was chosen as representative in final test.
5. The data is worse case.



Power	: AC 120V	Pol/Phase	: HORIZONTAL
Test Mode	: 802.11an HT40, CH151	Temperature	: 26 °C
Memo	:	Humidity	: 58 %

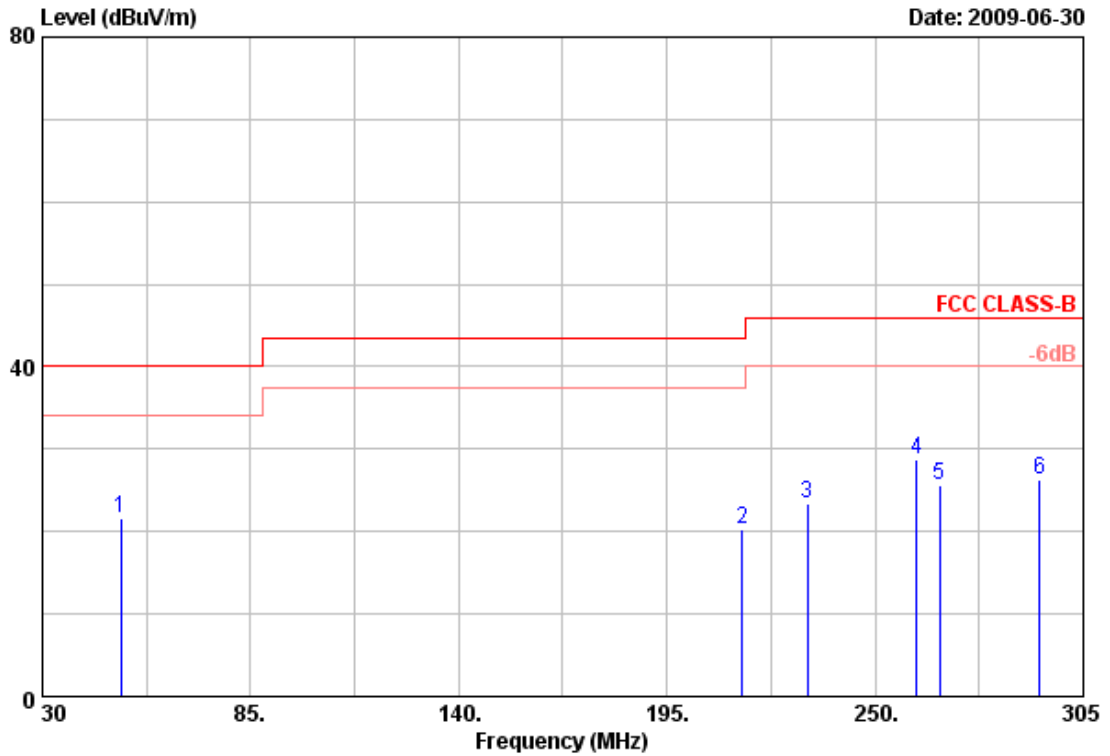

Item	Freq MHz	Read Value dBuV/m	Factor dB	Result dBuV/m	Limit dBuV/m	Margin dB	Remark	Ant Pos cm	Tab Pos Deg
1	50.63	36.27	-14.64	21.63	40.00	-18.37	Peak	104	0
2	214.80	36.95	-16.59	20.36	43.50	-23.14	Peak	104	0
3	232.13	39.46	-16.12	23.34	46.00	-22.66	Peak	104	0
4	261.00	42.70	-13.86	28.84	46.00	-17.16	Peak	104	0
5	267.05	39.08	-13.53	25.55	46.00	-20.45	Peak	104	0
6	293.45	39.85	-13.62	26.23	46.00	-19.77	Peak	104	0

Notes:

1. Result = Read Value + Factor
2. Factor = Antenna Factor + Cable Loss - Amplifier
3. The resolution bandwidth of test receiver/spectrum analyzer is 120KHz and video bandwidth is 300kHz for Peak detection and Quasi-peak detection at frequency below 1GHz.
4. According to technical experiences, all spurious emission of 802.11an mode at channel 151,155,159 are almost the same below 1GHz, so that the channel 151 was chosen as representative in final test.
5. The data is worse case.



Power	: AC 120V	Pol/Phase	: HORIZONTAL
Test Mode	: 802.11an HT40, CH151	Temperature	: 26 °C
Memo	:	Humidity	: 58 %

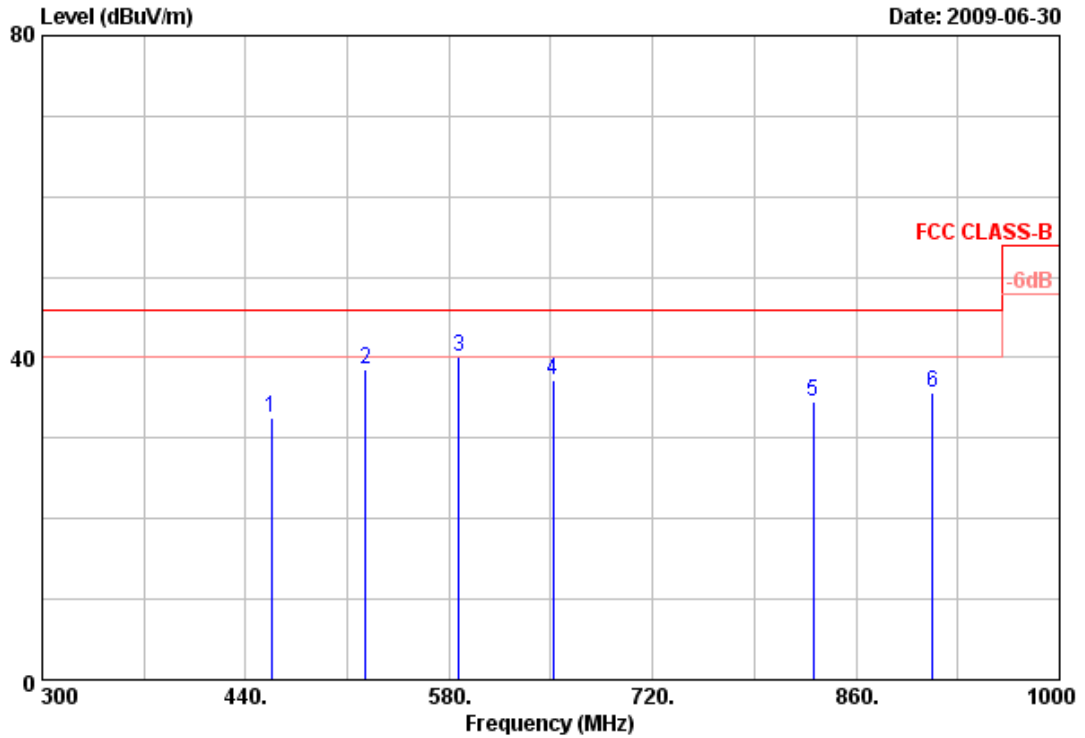

Item	Freq	Read Value	Factor	Result	Limit	Margin	Remark	Ant Pos	Tab Pos
	MHz	dBuV/m	dB	dBuV/m	dBuV/m	dB		cm	Deg
1	457.50	37.83	-5.27	32.56	46.00	-13.44	Peak	104	0
2	522.60	44.54	-6.07	38.47	46.00	-7.53	Peak	104	0
3	587.00	42.12	-2.05	40.07	46.00	-5.93	Peak	104	0
4	651.40	39.68	-2.36	37.32	46.00	-8.68	Peak	104	0
5	830.60	32.81	1.76	34.57	46.00	-11.43	Peak	104	0
6	912.50	33.20	2.35	35.55	46.00	-10.45	Peak	104	0

Notes:

1. Result = Read Value + Factor
2. Factor = Antenna Factor + Cable Loss - Amplifier
3. The resolution bandwidth of test receiver/spectrum analyzer is 120KHz and video bandwidth is 300kHz for Peak detection and Quasi-peak detection at frequency below 1GHz.
4. According to technical experiences, all spurious emission of 802.11an mode at channel 151,155,159 are almost the same below 1GHz, so that the channel 151 was chosen as representative in final test.
5. The data is worse case.



Power	: AC 120V	Pol/Phase	: VERTICAL
Test Mode	: 802.11an HT40, CH151	Temperature	: 26 °C
Memo	:	Humidity	: 58 %

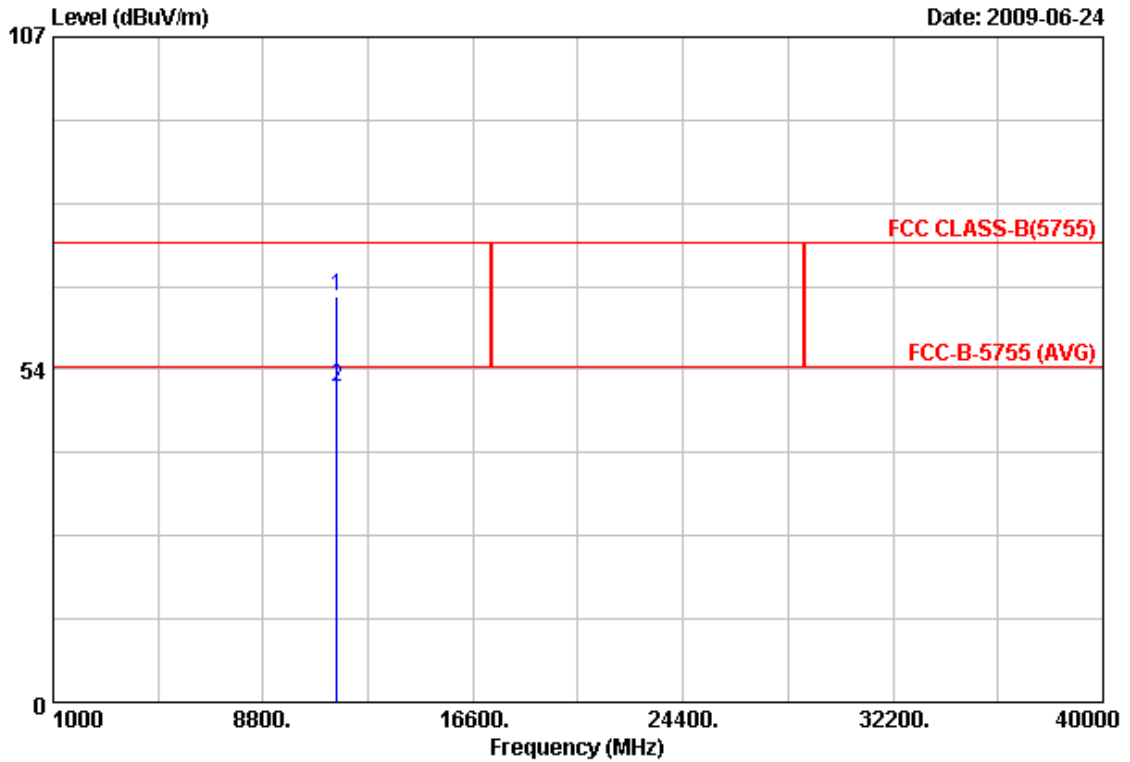

Item	Freq	Read Value	Factor	Result	Limit	Margin	Remark	Ant Pos	Tab Pos
	MHz	dBuV/m	dB	dBuV/m	dBuV/m	dB		cm	Deg
1	11551.70	46.79	18.54	65.33	74.00	-8.67	Peak	103	360
2	11553.45	32.16	18.54	50.70	54.00	-3.30	Average	103	360

Notes:

1. Result = Read Value + Factor
2. Factor = Antenna Factor + Cable Loss - Amplifier
3. The resolution bandwidth of test receiver/spectrum analyzer is 120KHz and video bandwidth is 300kHz for Peak detection and Quasi-peak detection at frequency below 1GHz.
4. The resolution bandwidth of test receiver/spectrum analyzer is 1MHz and video bandwidth is 3MHz for Peak detection at frequency above 1GHz.
5. The resolution bandwidth of test receiver/spectrum analyzer is 1MHz and video bandwidth is 10Hz for Average detection at frequency above 1GHz.
6. The other emissions is too low to be measured.



Power	: AC 120V	Pol/Phase	: HORIZONTAL
Test Mode	: 802.11an HT40, CH151	Temperature	: 26 °C
Memo	:	Humidity	: 58 %

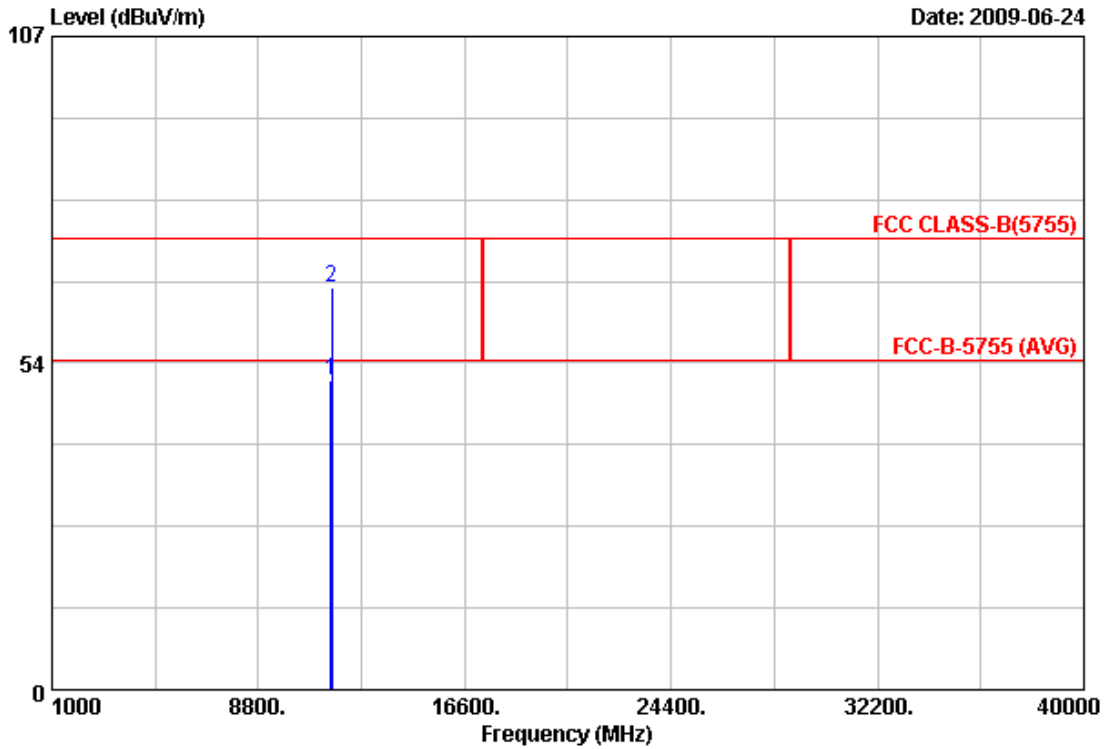

Item	Freq	Read Value	Factor	Result	Limit	Margin	Remark	Ant Pos	Tab Pos
	MHz	dBuV/m	dB	dBuV/m	dBuV/m	dB		cm	Deg
1	11553.45	32.21	18.54	50.75	54.00	-3.25	Average	104	360
2	11558.40	47.30	18.55	65.85	74.00	-8.15	Peak	104	360

Notes:

1. Result = Read Value + Factor
2. Factor = Antenna Factor + Cable Loss - Amplifier
3. The resolution bandwidth of test receiver/spectrum analyzer is 120KHz and video bandwidth is 300kHz for Peak detection and Quasi-peak detection at frequency below 1GHz.
4. The resolution bandwidth of test receiver/spectrum analyzer is 1MHz and video bandwidth is 3MHz for Peak detection at frequency above 1GHz.
5. The resolution bandwidth of test receiver/spectrum analyzer is 1MHz and video bandwidth is 10Hz for Average detection at frequency above 1GHz.
6. The other emissions is too low to be measured.



Power	: AC 120V	Pol/Phase	: VERTICAL
Test Mode	: 802.11an HT40, CH159	Temperature	: 26 °C
Memo	:	Humidity	: 58 %

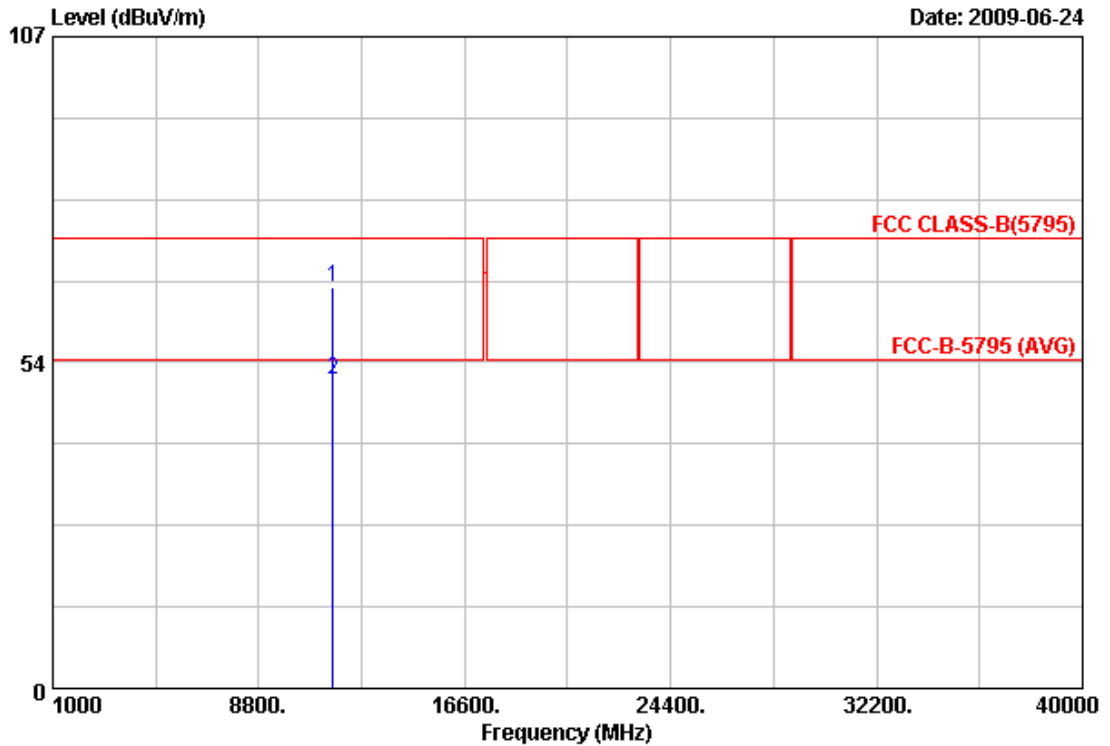

Item	Freq	Read Value	Factor	Result	Limit	Margin	Remark	Ant Pos	Tab Pos
	MHz	dBuV/m	dB	dBuV/m	dBuV/m	dB		cm	Deg
1	11596.10	47.39	18.58	65.97	74.00	-8.03	Peak	104	360
2	11599.75	32.12	18.58	50.70	54.00	-3.30	Average	104	360

Notes:

1. Result = Read Value + Factor
2. Factor = Antenna Factor + Cable Loss - Amplifier
3. The resolution bandwidth of test receiver/spectrum analyzer is 120KHz and video bandwidth is 300kHz for Peak detection and Quasi-peak detection at frequency below 1GHz.
4. The resolution bandwidth of test receiver/spectrum analyzer is 1MHz and video bandwidth is 3MHz for Peak detection at frequency above 1GHz.
5. The resolution bandwidth of test receiver/spectrum analyzer is 1MHz and video bandwidth is 10Hz for Average detection at frequency above 1GHz.
6. The other emissions is too low to be measured.



Power	: AC 120V	Pol/Phase	: HORIZONTAL
Test Mode	: 802.11an HT40, CH159	Temperature	: 26 °C
Memo	:	Humidity	: 58 %

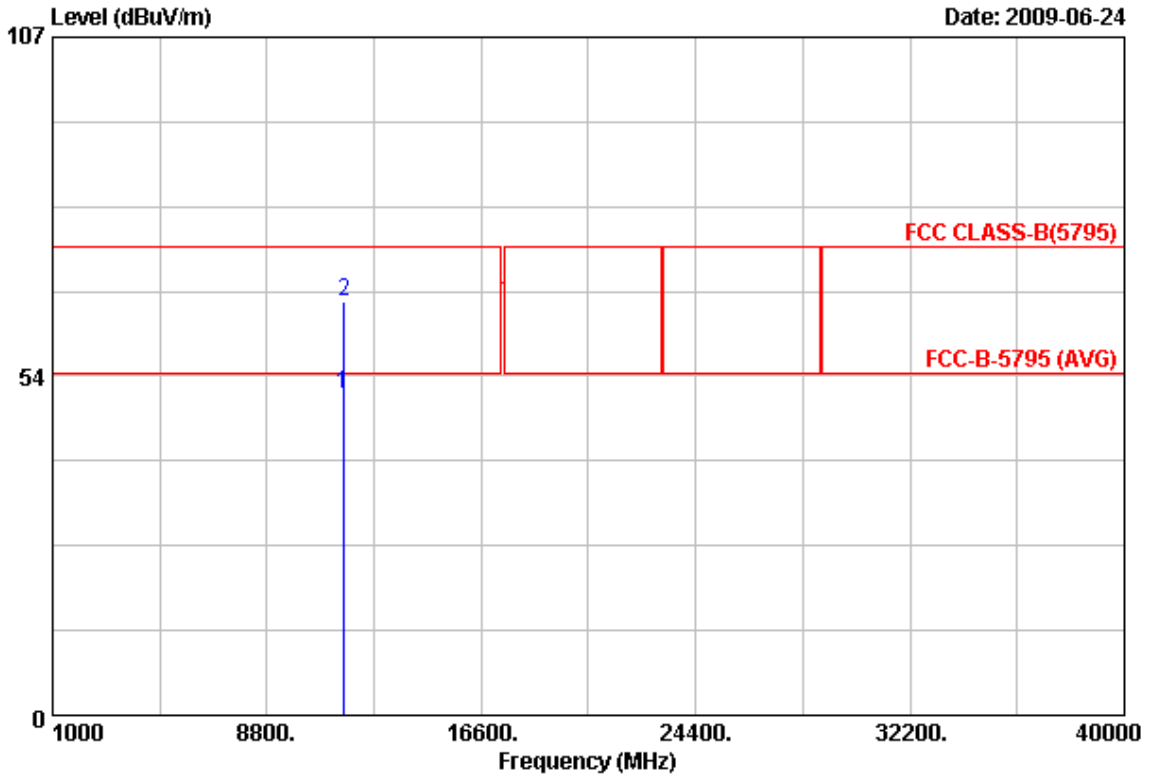

Item	Freq	Read Value	Factor	Result	Limit	Margin	Remark	Ant Pos	Tab Pos
	MHz	dBuV/m	dB	dBuV/m	dBuV/m	dB		cm	Deg
1	11592.15	32.02	18.58	50.60	54.00	-3.40	Average	104	360
2	11598.05	46.74	18.58	65.32	74.00	-8.68	Peak	104	360

Notes:

1. Result = Read Value + Factor
2. Factor = Antenna Factor + Cable Loss - Amplifier
3. The resolution bandwidth of test receiver/spectrum analyzer is 120KHz and video bandwidth is 300kHz for Peak detection and Quasi-peak detection at frequency below 1GHz.
4. The resolution bandwidth of test receiver/spectrum analyzer is 1MHz and video bandwidth is 3MHz for Peak detection at frequency above 1GHz.
5. The resolution bandwidth of test receiver/spectrum analyzer is 1MHz and video bandwidth is 10Hz for Average detection at frequency above 1GHz.
6. The other emissions is too low to be measured.

Test engineer: Ben



6. 6dB Bandwidth Measurement Data

6.1 Test Limit

The minimum of 6dB Bandwidth Measurement is 0.5 MHz.

6.2 Test Procedures

- a. The transmitter output was connected to the spectrum analyzer.
- b. Set RBW of spectrum analyzer to 100 KHz and VBW to 100 KHz.
- c. The 6 dB bandwidth is defined as the total spectrum the power of which is higher than peak power minus 6 dB.

6.3 Test Setup Layout

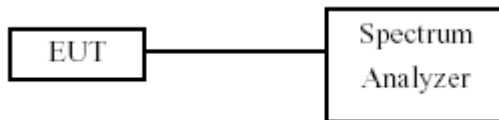

6.4 Measurement Equipment

Instrument/Ancillary	Model No.	Manufacturer	Serial No.	Calibration Date	Valid Date
Spectrum Analyzer	FSP40	R&S	10047	2009/02/21	2010/02/20



6.5 Test Result and Data

Test Date: Jun. 10, 2009

Temperature: 26

Atmospheric pressure: 1012 hPa

Humidity: 64%

Modulation Standard	Channel	Frequency (MHz)	6dB Bandwidth (MHz)
802.11b (11Mbps)	01	2412	11.9
	06	2437	12.2
	11	2462	12.1
802.11g (54Mbps)	01	2412	16.5
	06	2437	16.5
	11	2462	16.7
802.11n HT20 (65Mbps)	01	2412	17.6
	06	2437	17.7
	11	2462	17.7
802.11n HT40 (130Mbps)	03	2422	36.4
	06	2437	36.0
	09	2452	36.4

Test Date: Jun. 09, 2009

Temperature: 27

Atmospheric pressure: 1015 hPa

Humidity: 61%

Modulation Standard	Channel	Frequency (MHz)	6dB Bandwidth (MHz)
802.11a (54Mbps)	149	5745	16.7
	157	5785	16.6
	165	5825	16.5
802.11an HT20 (65Mbps)	149	5745	17.8
	157	5785	17.5
	165	5825	17.8
802.11an HT40 (130Mbps)	151	5755	36.2
	155	5775	---
	159	5795	35.2



Modulation Standard: 802.11b (11Mbps)
Channel: 01

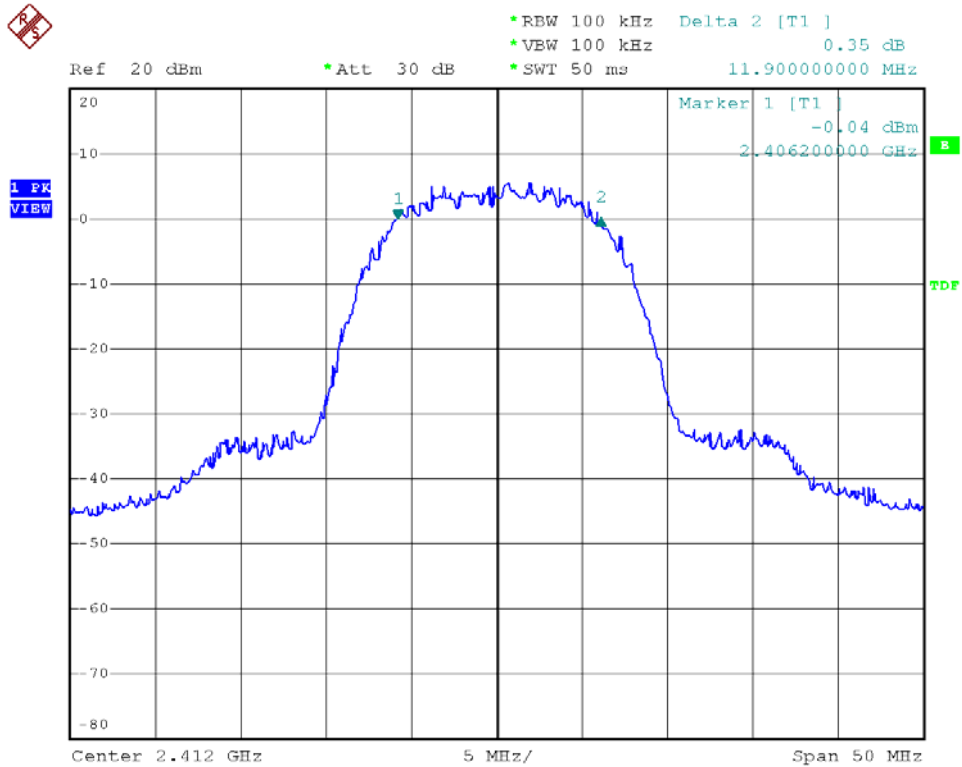

Modulation Standard: 802.11b (11Mbps),
Channel: 06

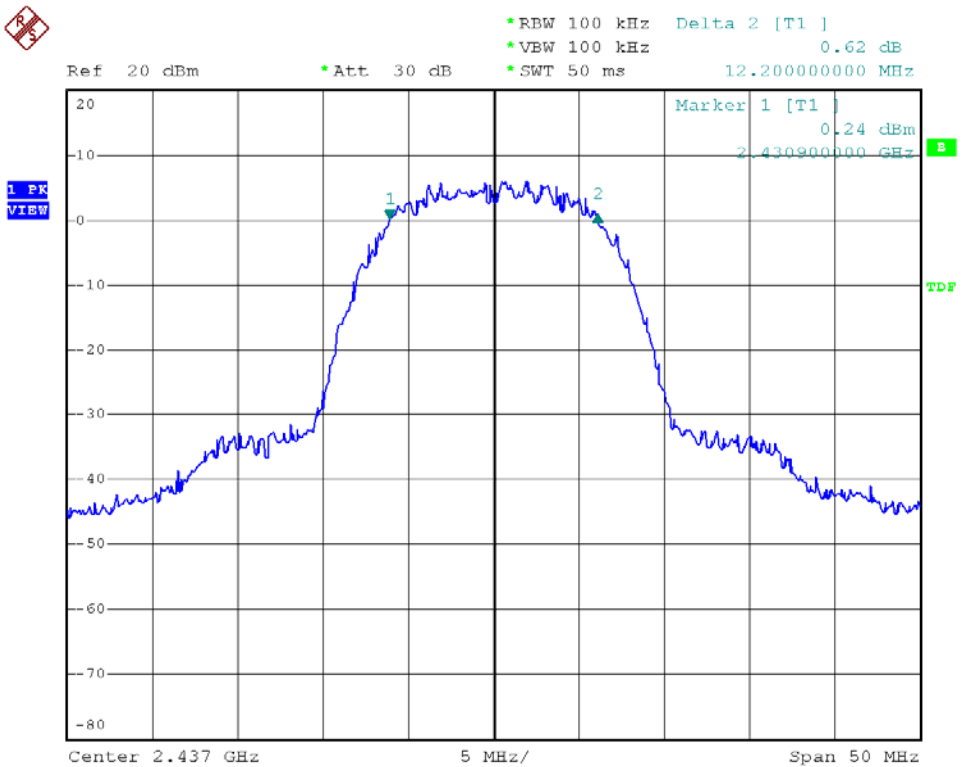



Modulation Standard: 802.11b (11Mbps)
Channel: 11

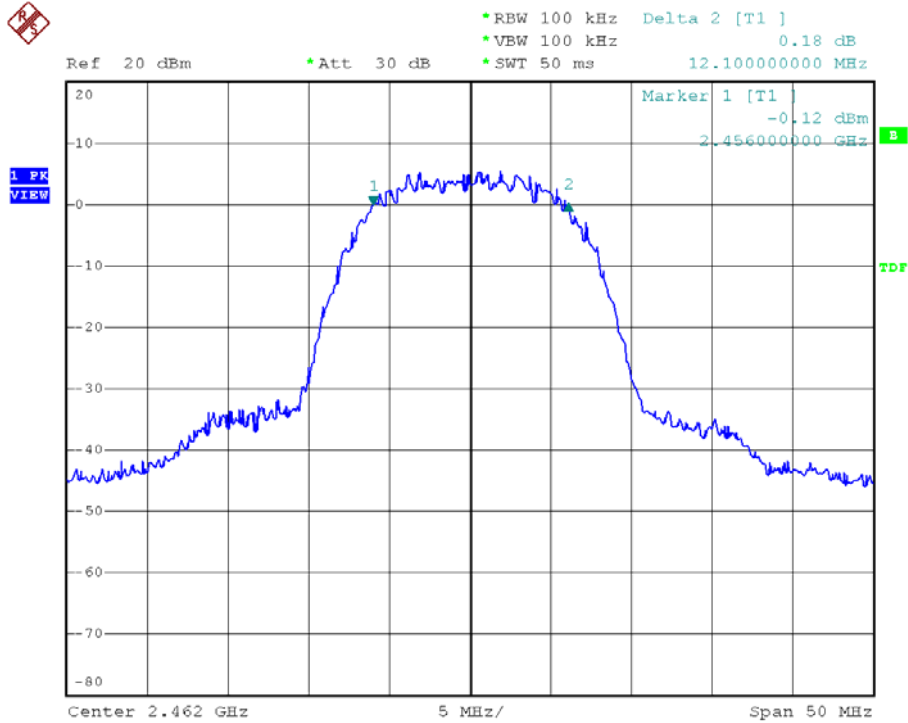

Modulation Standard: 802.11g (54Mbps)
Channel: 01

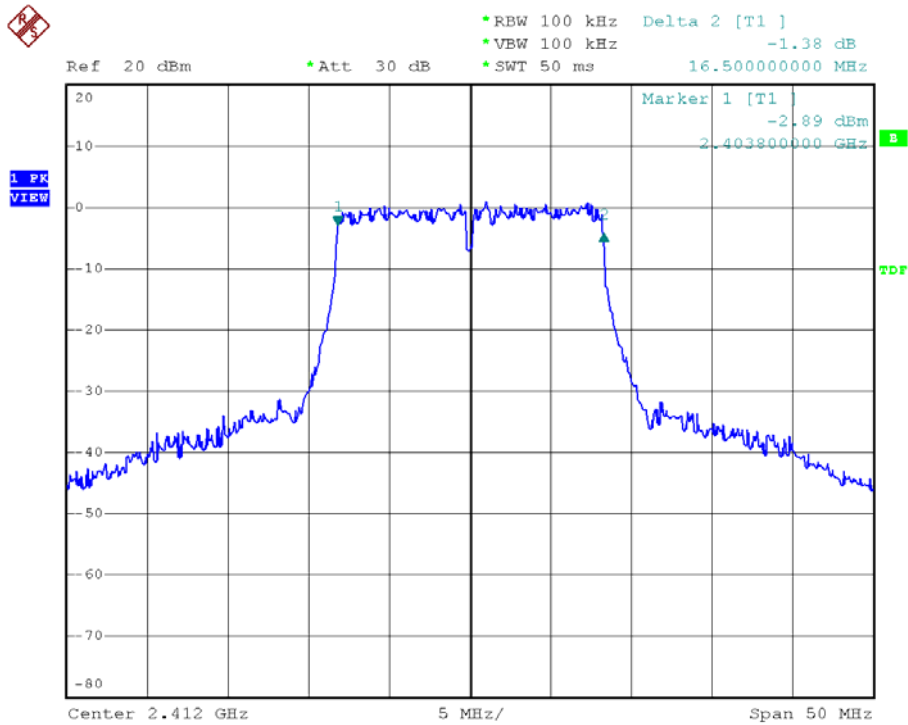



Modulation Standard: 802.11g (54Mbps)
Channel: 06

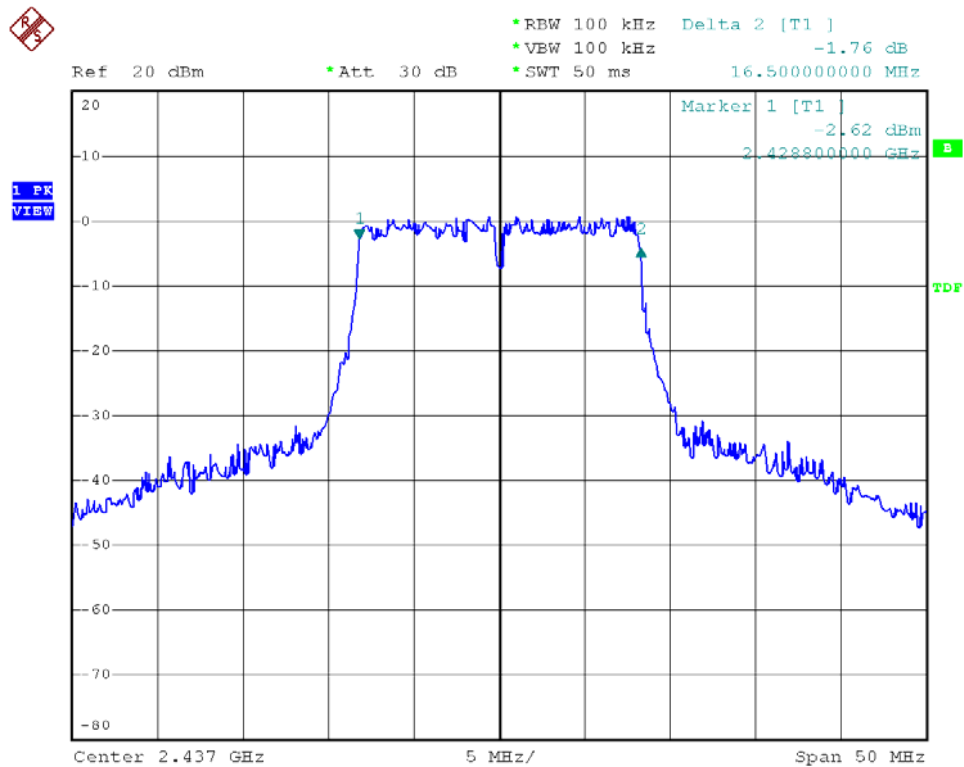

Modulation Standard: 802.11g (54Mbps)
Channel: 11

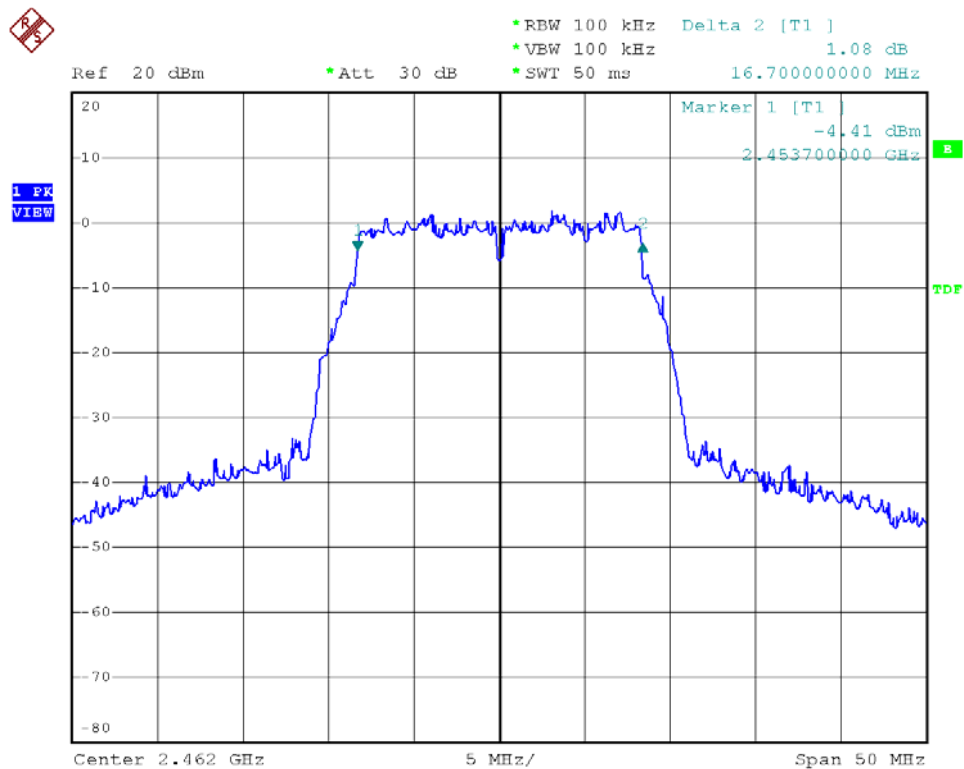



Modulation Standard: 802.11n, HT20 (65Mbps)
Channel: 01

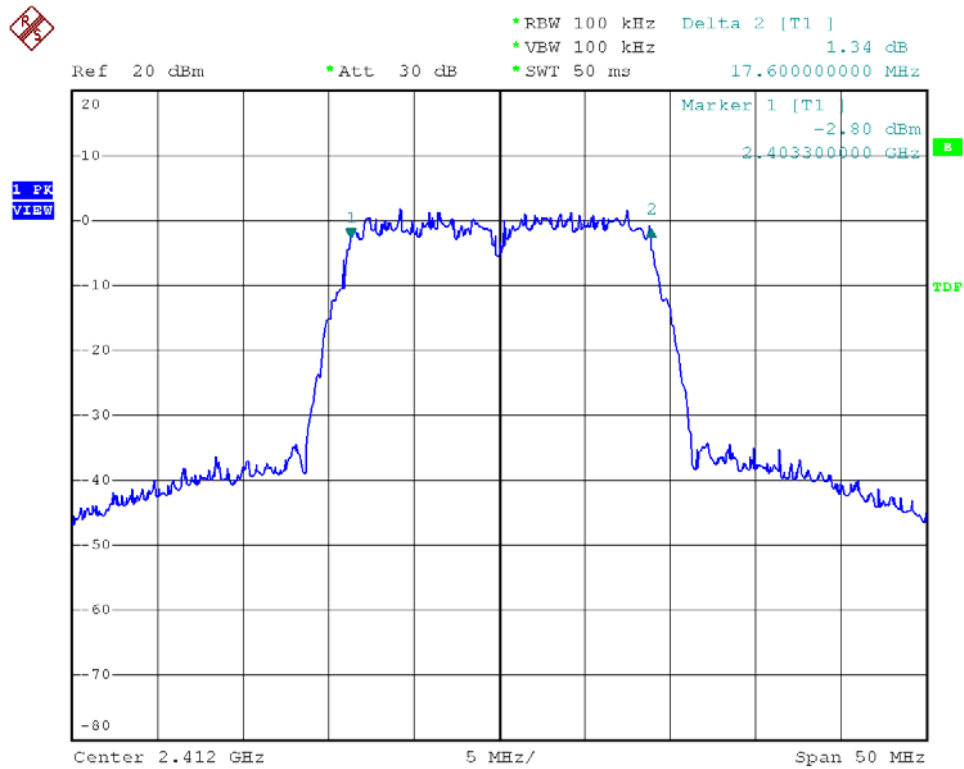

Modulation Standard: 802.11n, HT20 (65Mbps)
Channel: 06

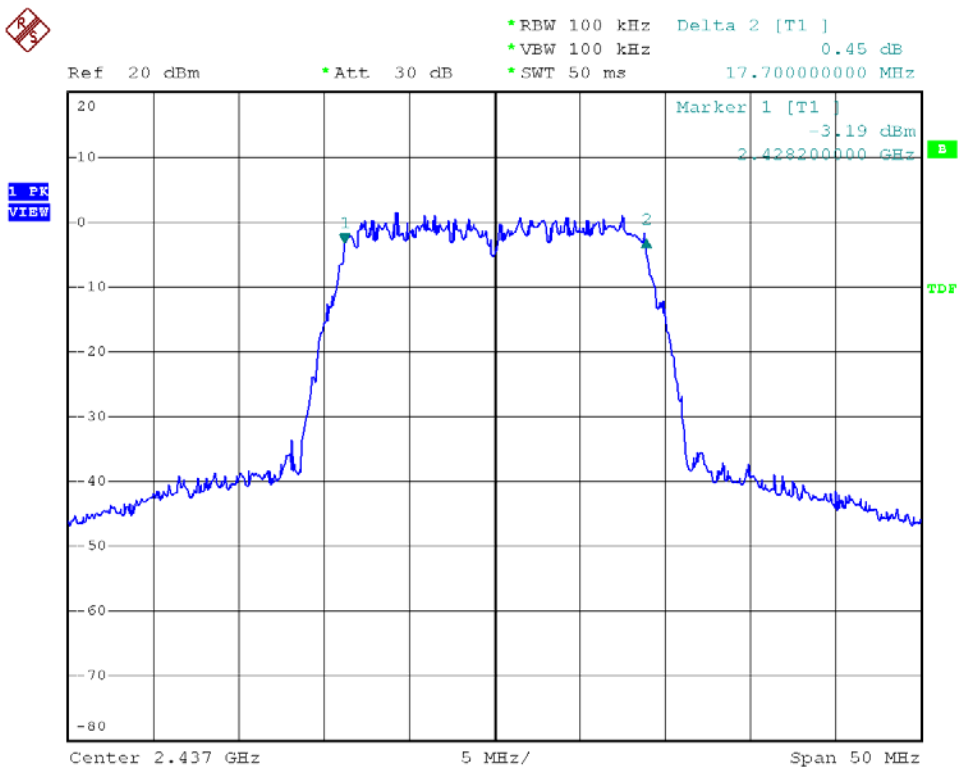



Modulation Standard: 802.11n, HT20 (65Mbps)
Channel: 11

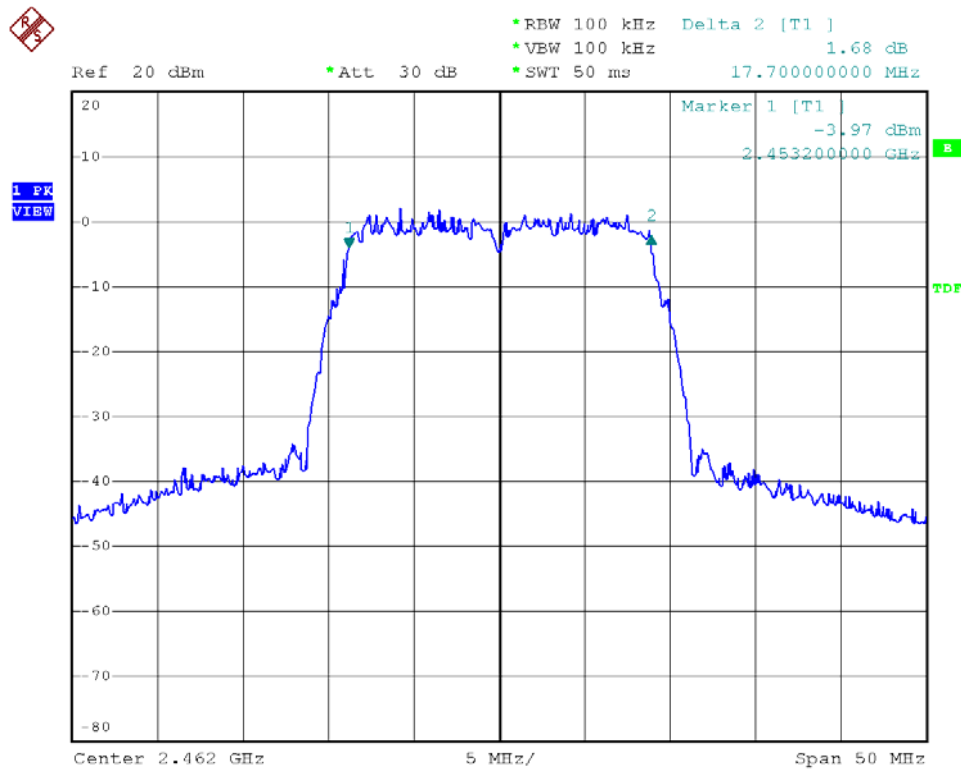

Modulation Standard: 802.11n, HT40 (130Mbps)
Channel: 03

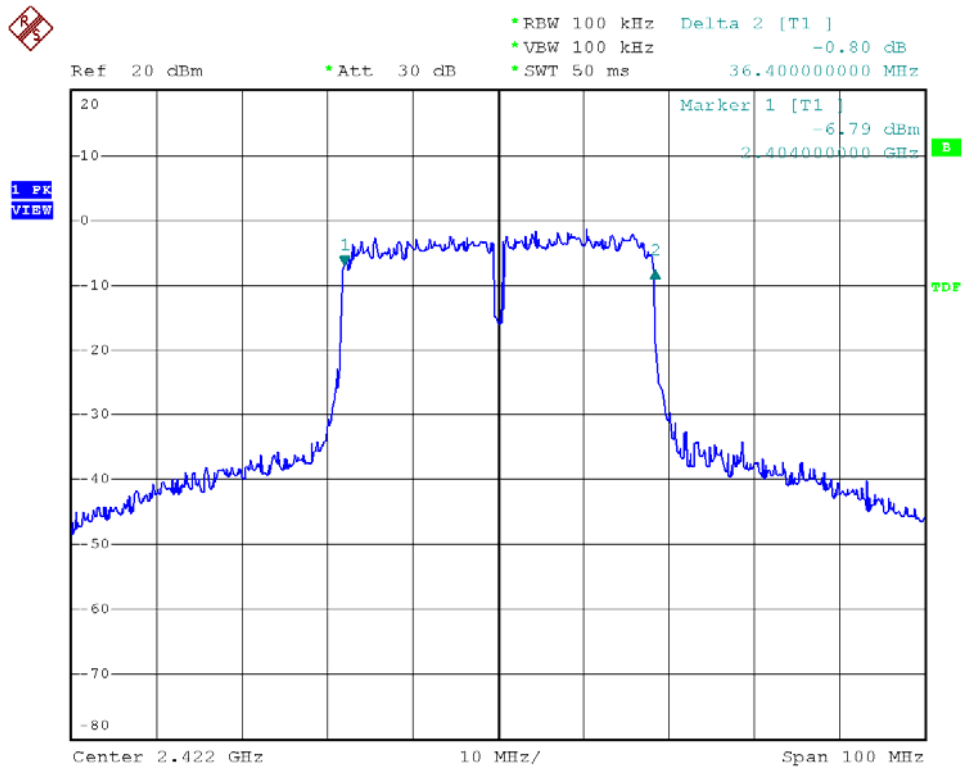



Modulation Standard: 802.11n, HT40 (130Mbps)
Channel: 06

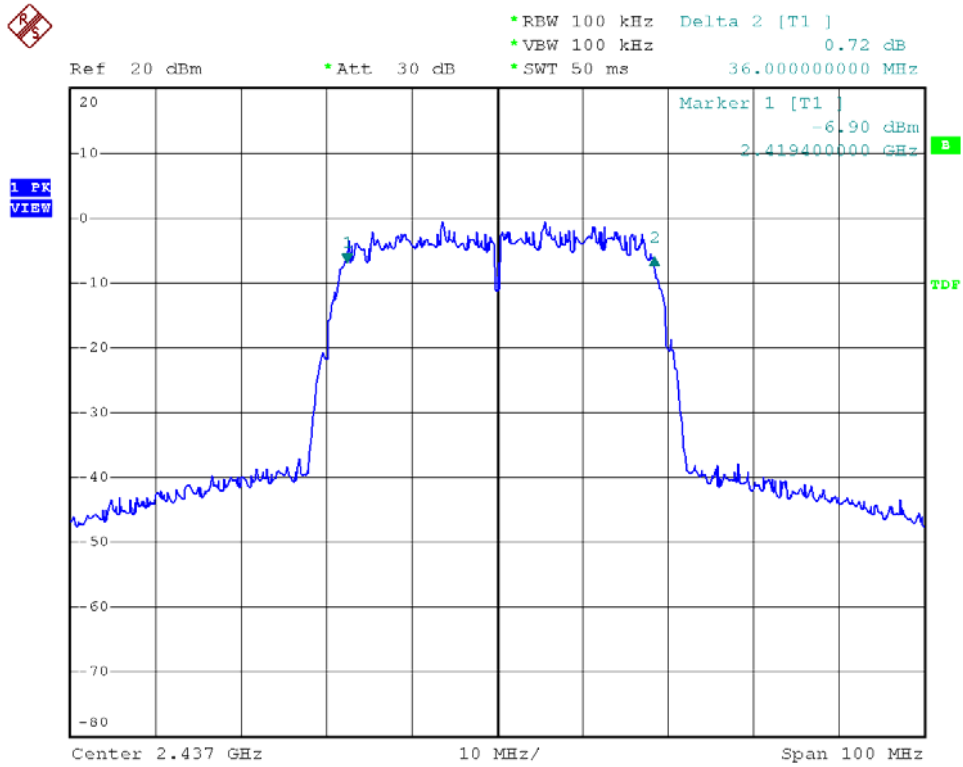

Modulation Standard: 802.11n, HT40 (130Mbps)
Channel: 09

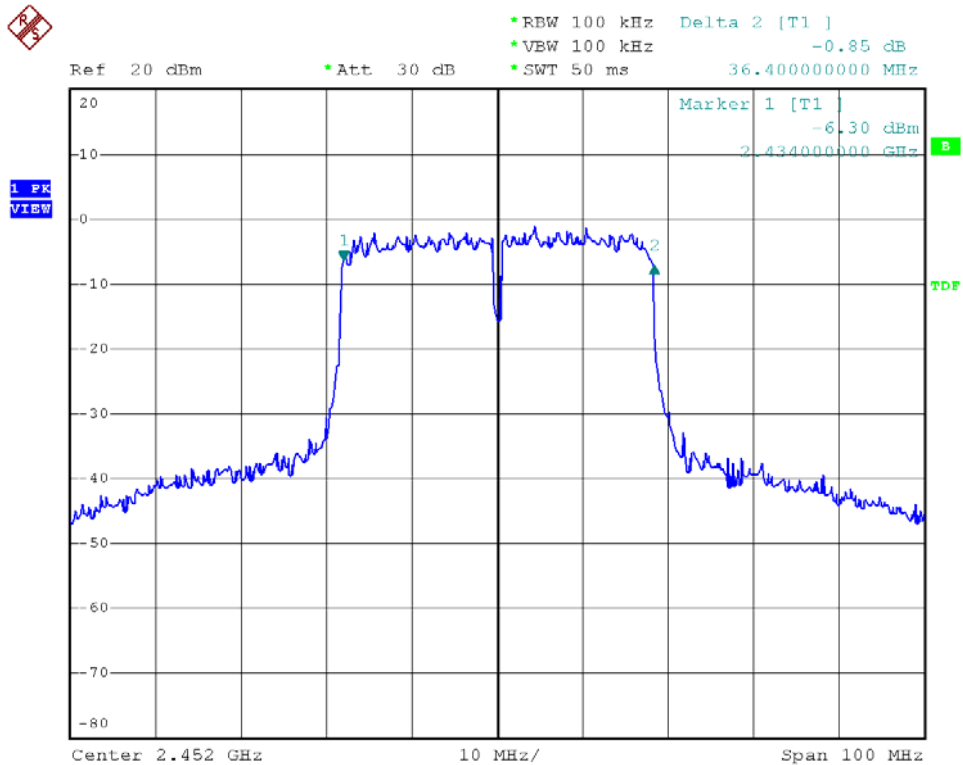



Modulation Standard: 802.11a (54Mbps)
Channel: 149

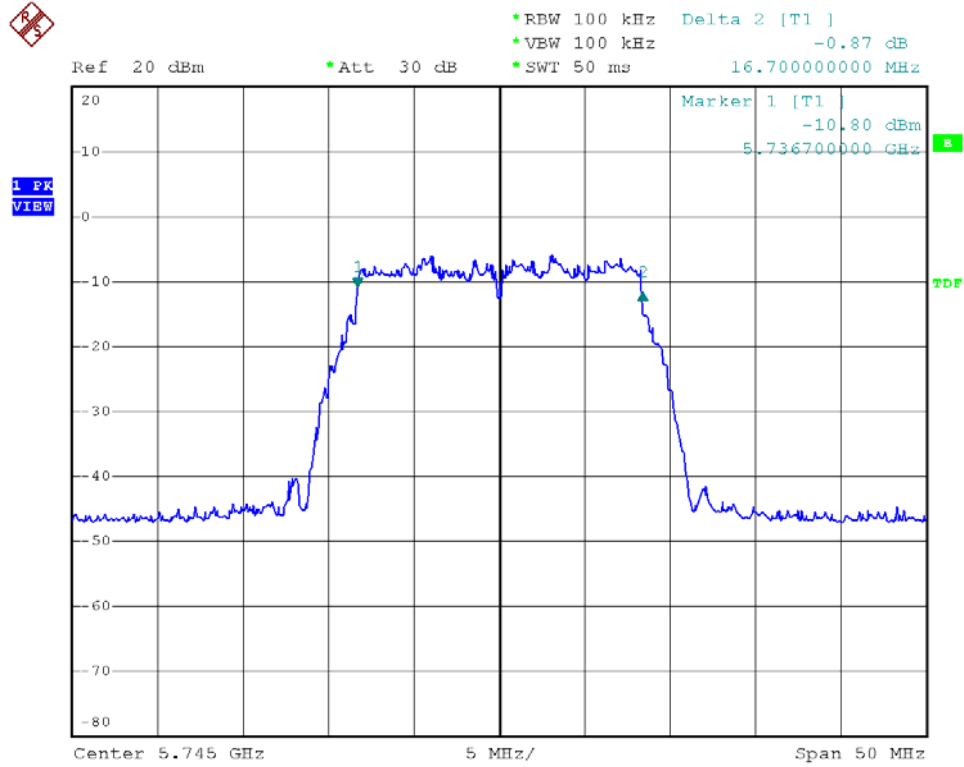

Modulation Standard: 802.11a (54Mbps)
Channel: 157

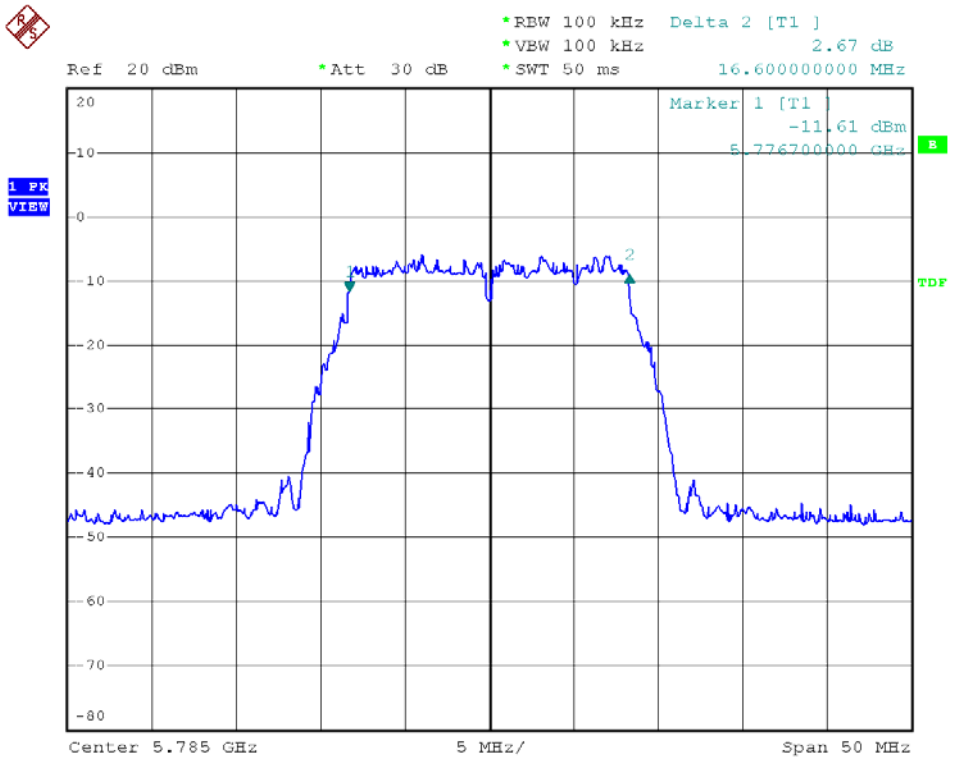



Modulation Standard: 802.11a (54Mbps)
Channel: 165

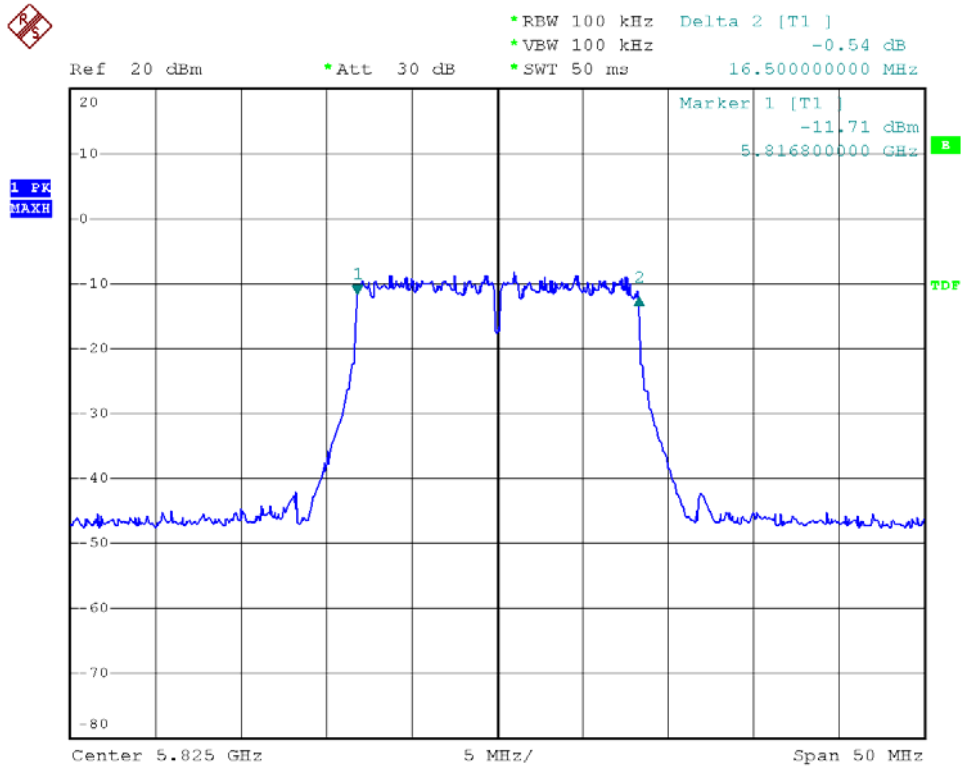

Modulation Standard: 802.11an, HT20 (65Mbps)
Channel: 149

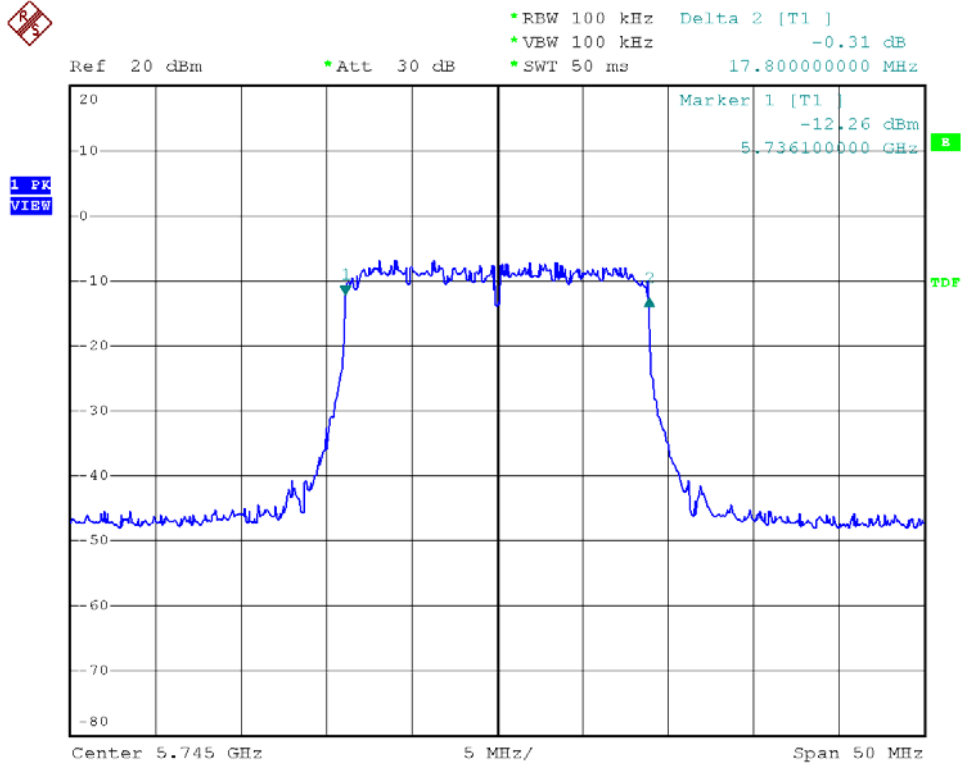



Modulation Standard: 802.11an, HT20 (65Mbps)
Channel: 157

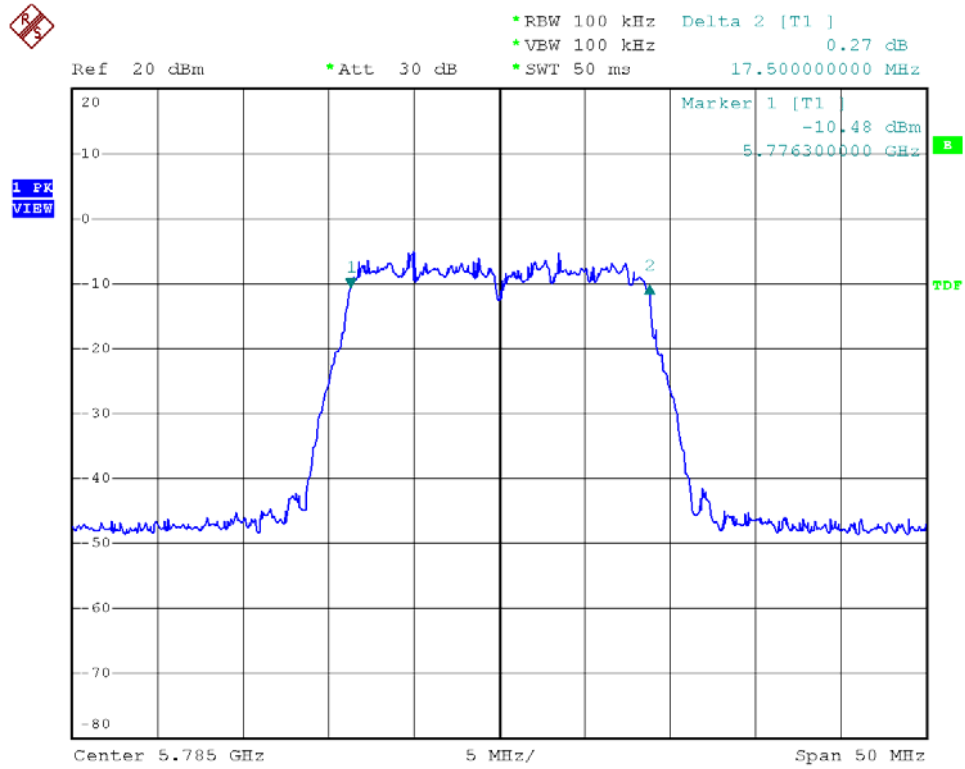

Modulation Standard: 802.11an, HT20 (65Mbps)
Channel: 165

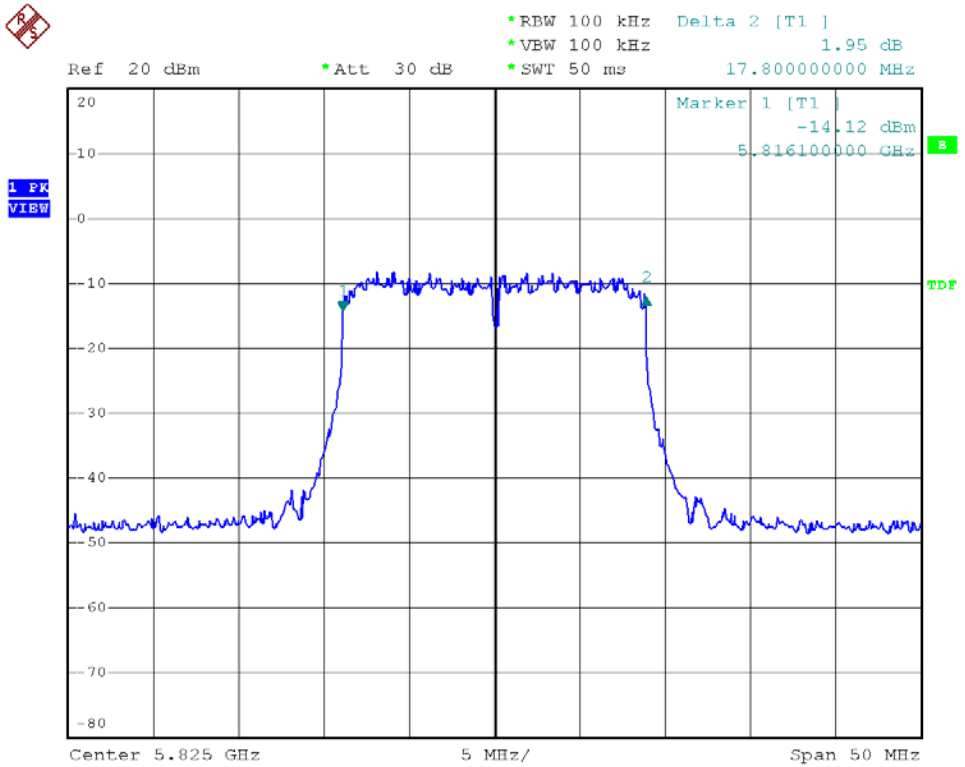



Modulation Standard: 802.11an, HT40 (130Mbps)
Channel: 151

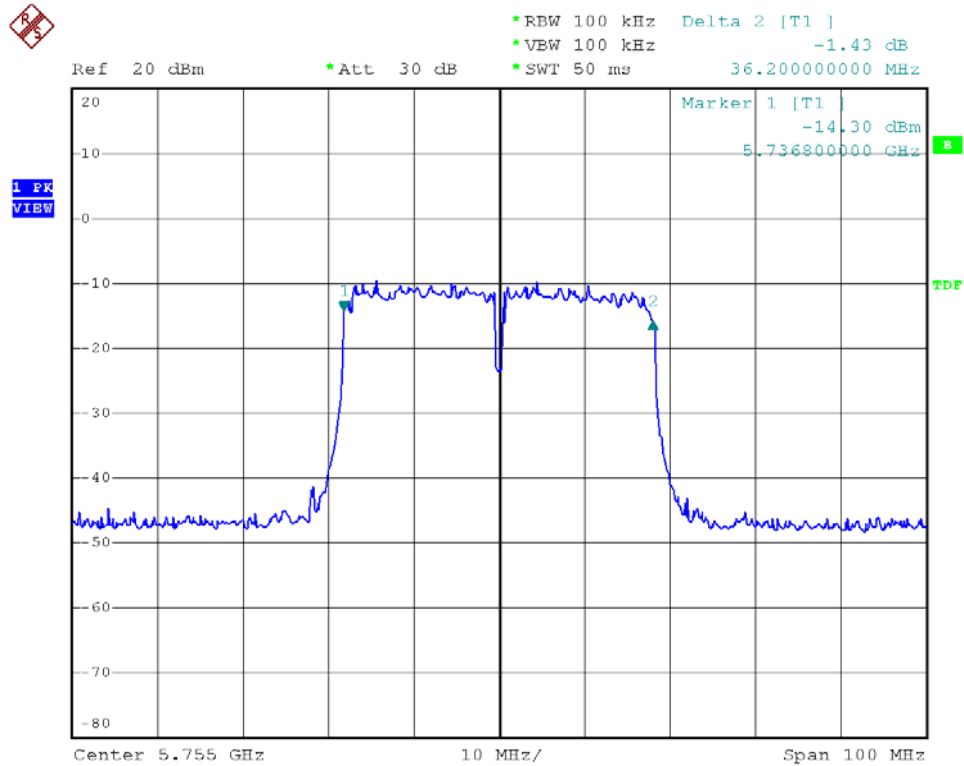

Modulation Standard: 802.11an, HT40 (130Mbps)
Channel: 159

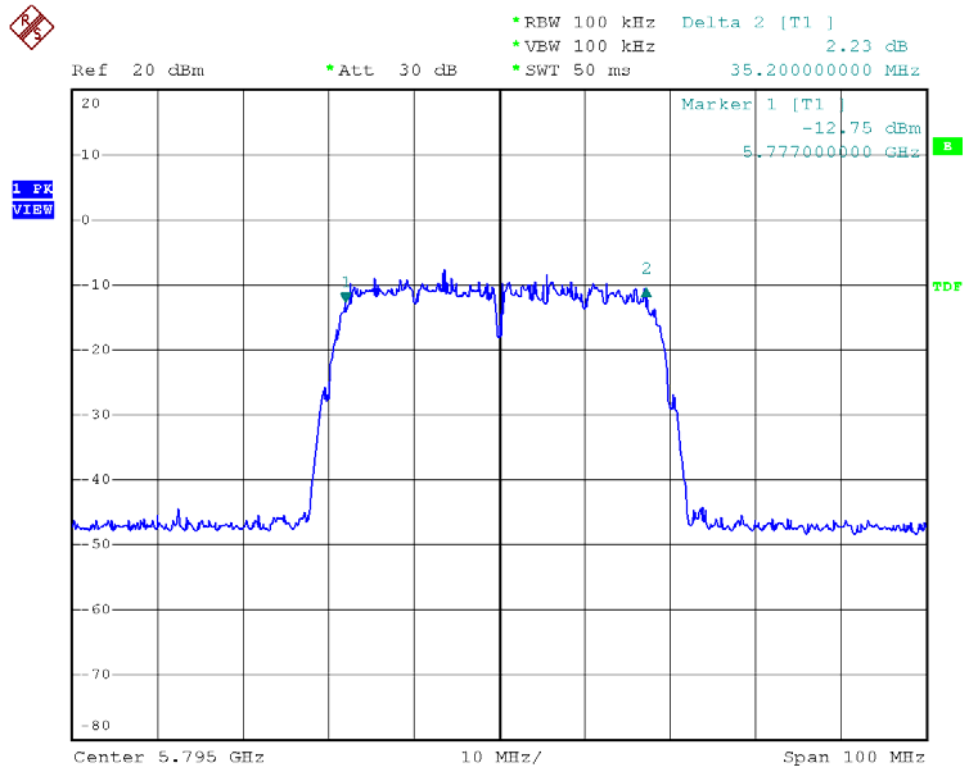



7. Maximum Peak Output Power

7.1 Test Limit

The Maximum Peak Output Power Measurement is 30dBm.

7.2 Test Procedures

The antenna port (RF output) of the EUT was connected to the input (RF input) of a power meter. Power was read directly from the meter and cable loss connection was added to the reading to obtain power at the EUT antenna terminal. The EUT Output Power was set to maximum to produce the worse case test result.

7.3 Test Setup Layout

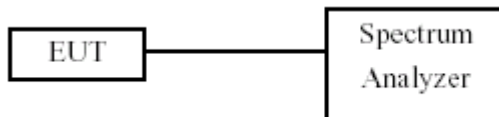

7.4 Measurement Equipment

Instrument/Ancillary	Model No.	Manufacturer	Serial No.	Calibration Date	Valid Date
Spectrum Analyzer	FSP40	R&S	10047	2009/02/21	2010/02/20

7.5 Test Result and Data

Test Date: Jun. 10, 2009

Temperature: 26

Atmospheric pressure: 1012 hPa

Humidity: 64%

Modulation Standard	Channel	Frequency (MHz)	Peak Power Output (dBm)	Peak Power Output (mW)
802.11b (11Mbps)	01	2412	17.00	50.1
	06	2437	17.05	50.7
	11	2462	17.00	50.1
802.11g (54Mbps)	01	2412	13.89	24.5
	06	2437	13.54	22.6
	11	2462	13.81	24.0



Test Date: Jun. 10, 2009

Temperature: 26

Atmospheric pressure: 1012 hPa

Humidity: 64%

Modulation Standard	Channel	Frequency (MHz)	Peak Power Output (dBm)	Peak Power Output (mW)
802.11n HT20 (65Mbps)	01	2412	13.81	24.0
	06	2437	13.52	22.5
	11	2462	13.68	23.3
802.11n HT40 (130Mbps)	03	2422	13.84	24.2
	06	2437	13.67	23.3
	09	2452	13.89	24.5

Test Date: Jun. 10, 2009

Temperature: 26

Atmospheric pressure: 1012 hPa

Humidity: 64%

Modulation Standard	Channel	Frequency (MHz)	Peak Power Output (dBm)	Peak Power Output (mW)
802.11a (54Mbps)	149	5745	13.91	24.6
	157	5785	14.02	25.2
	165	5825	13.40	21.9

Modulation Standard	Channel	Frequency (MHz)	Peak Power Output (dBm)	Peak Power Output (mW)
802.11an HT20 (65Mbps)	149	5745	13.52	22.5
	157	5785	13.64	23.1
	165	5825	14.28	26.8
802.11an HT40 (130Mbps)	151	5755	14.68	29.4
	155	5775	-----	-----
	159	5795	14.72	29.6



Modulation Standard: 802.11b (11Mbps)
Channel: 01

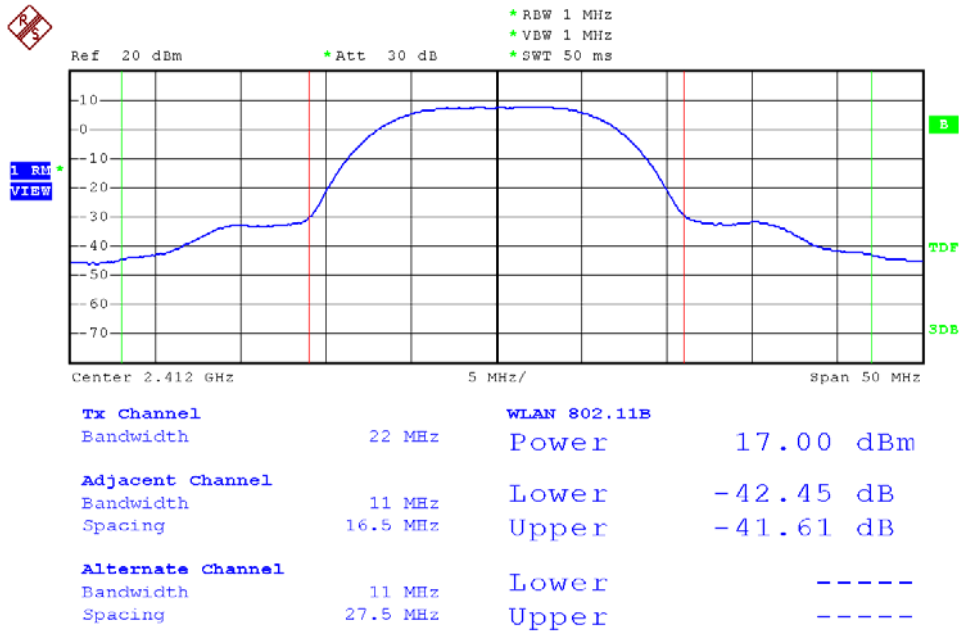

Modulation Standard: 802.11b (11Mbps)
Channel: 06

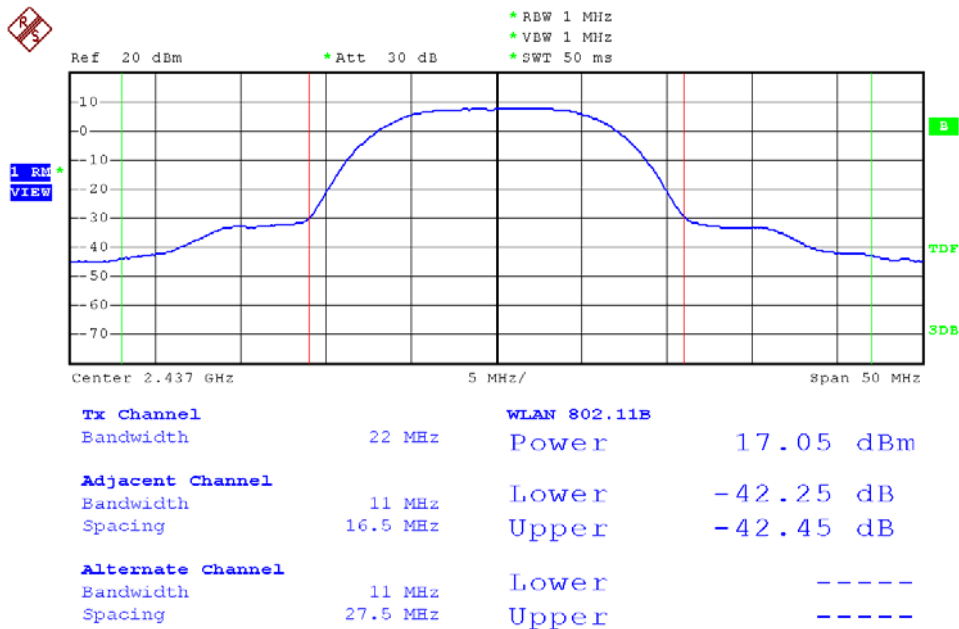



Modulation Standard: 802.11b (11Mbps)
Channel: 11

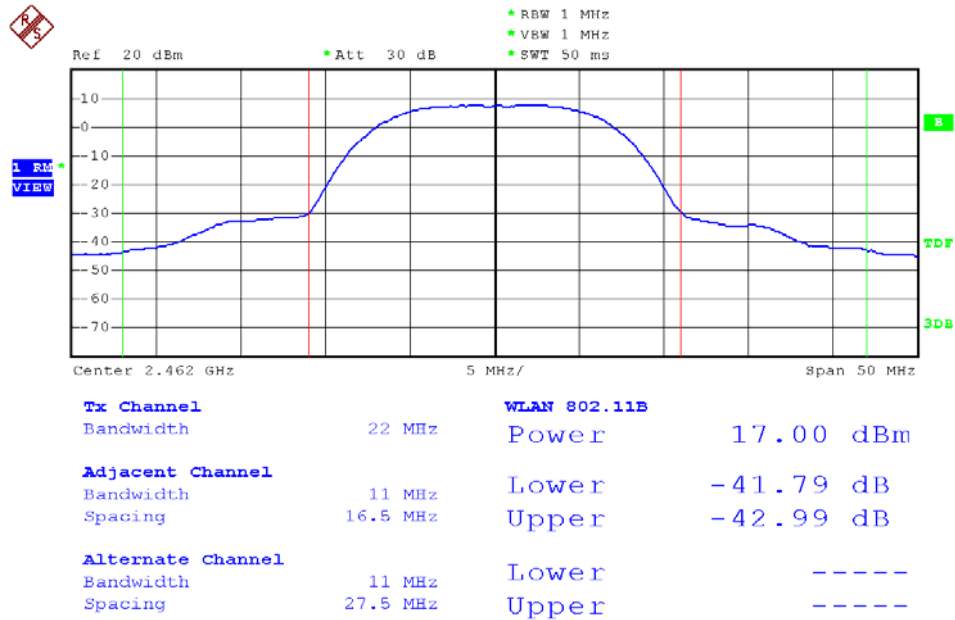

Modulation Standard: 802.11g (54Mbps)
Channel: 01

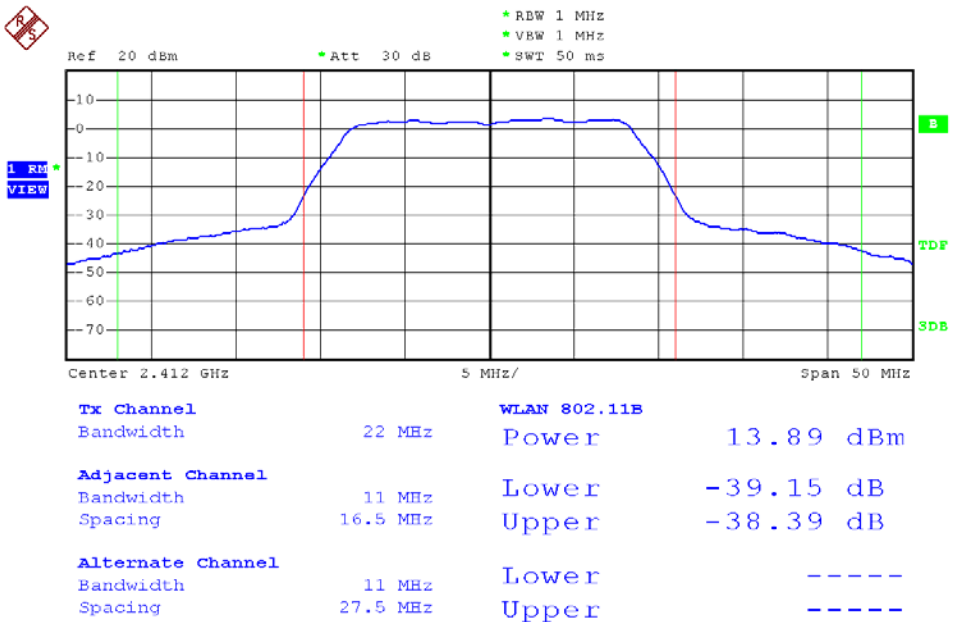



Modulation Standard: 802.11g (54Mbps)
Channel: 06

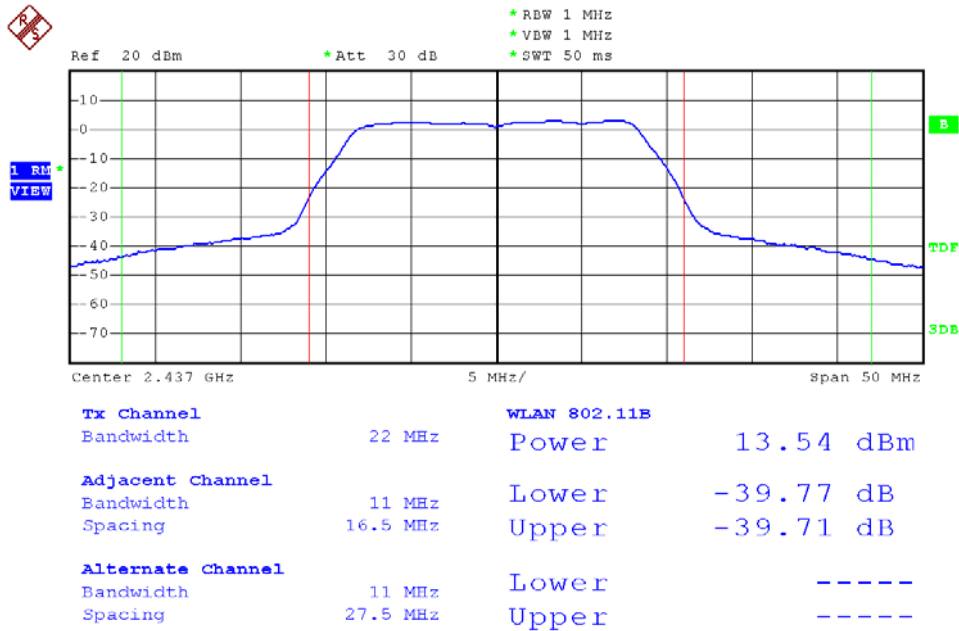

Modulation Standard: 802.11g (54Mbps)
Channel: 11

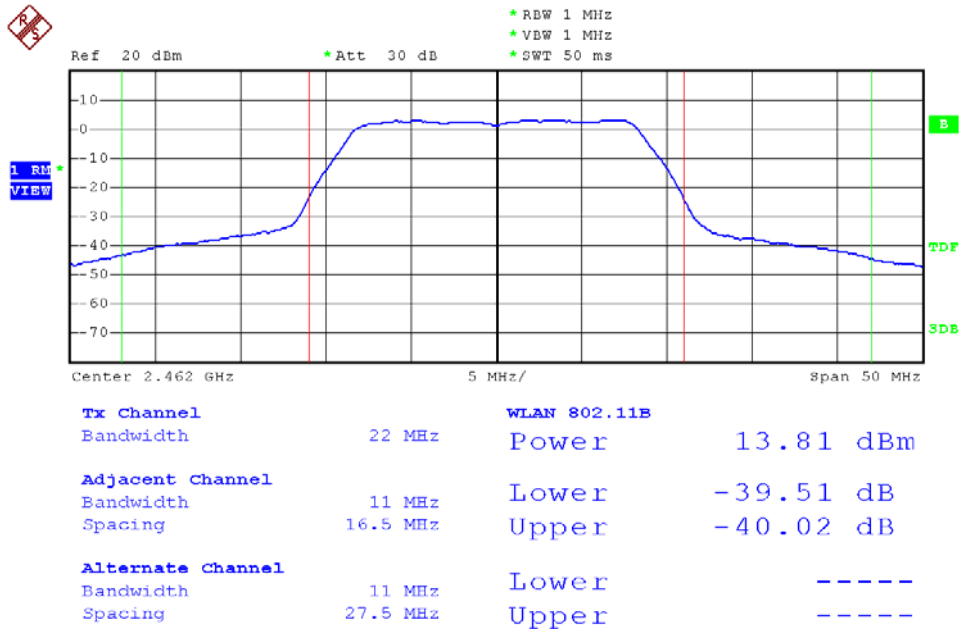



Modulation Standard: 802.11n, HT20 (65Mbps)
Channel: 01

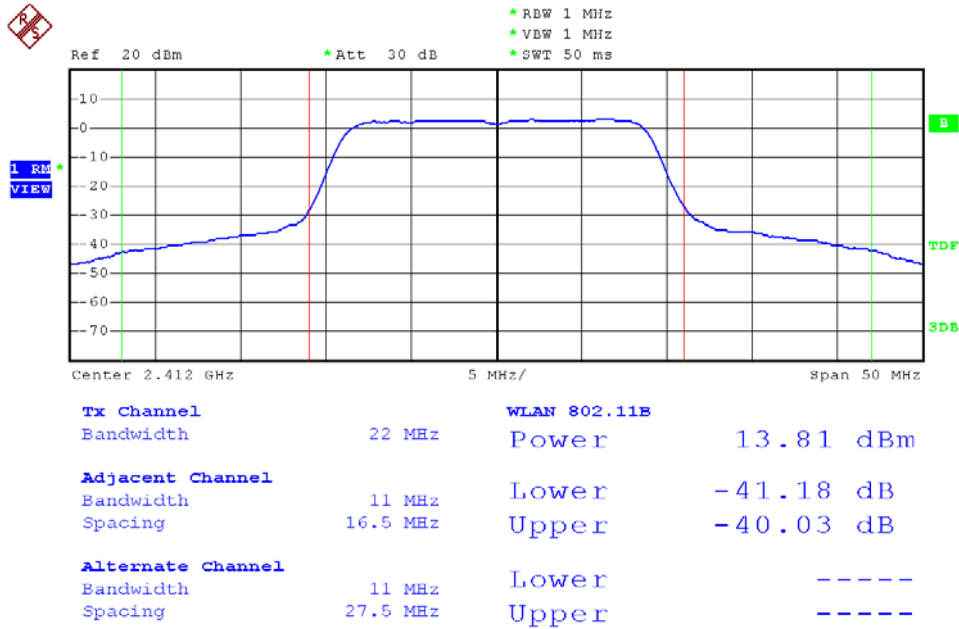

Modulation Standard: 802.11n, HT20 (65Mbps)
Channel: 06

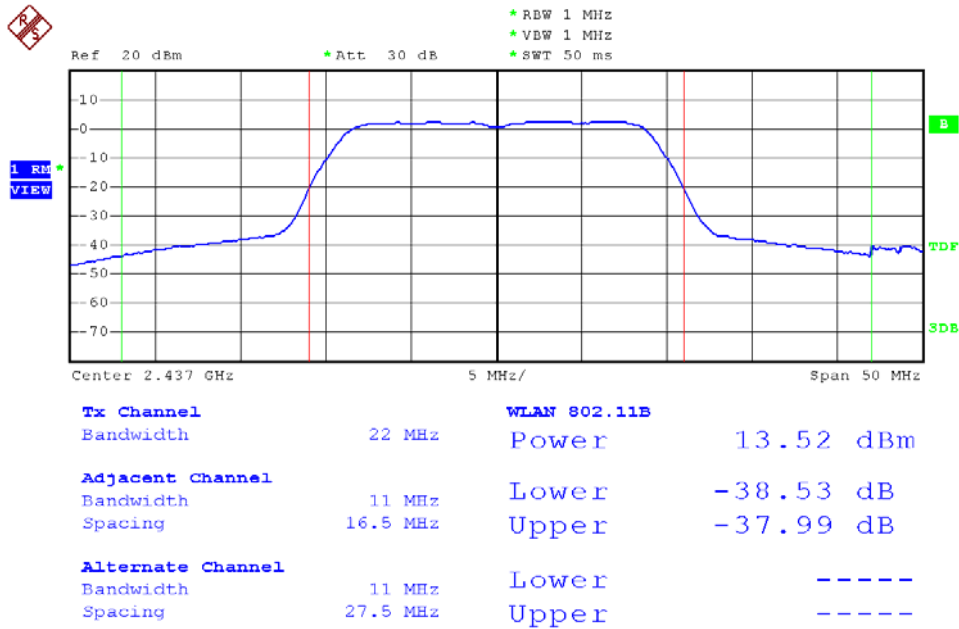



Modulation Standard: 802.11n, HT20 (65Mbps)
Channel: 11

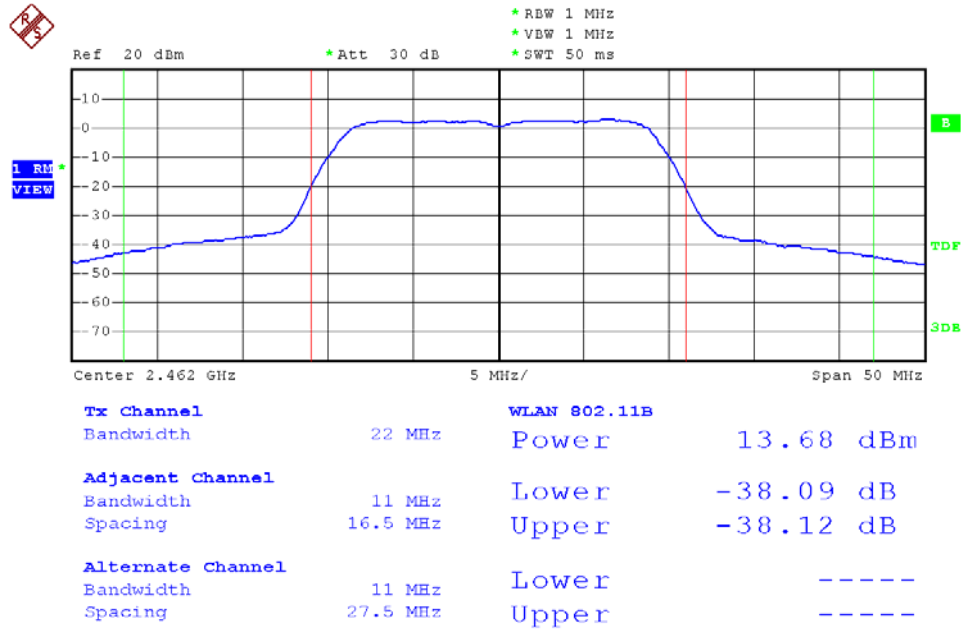

Modulation Standard: 802.11n, HT40 (130Mbps)
Channel: 03

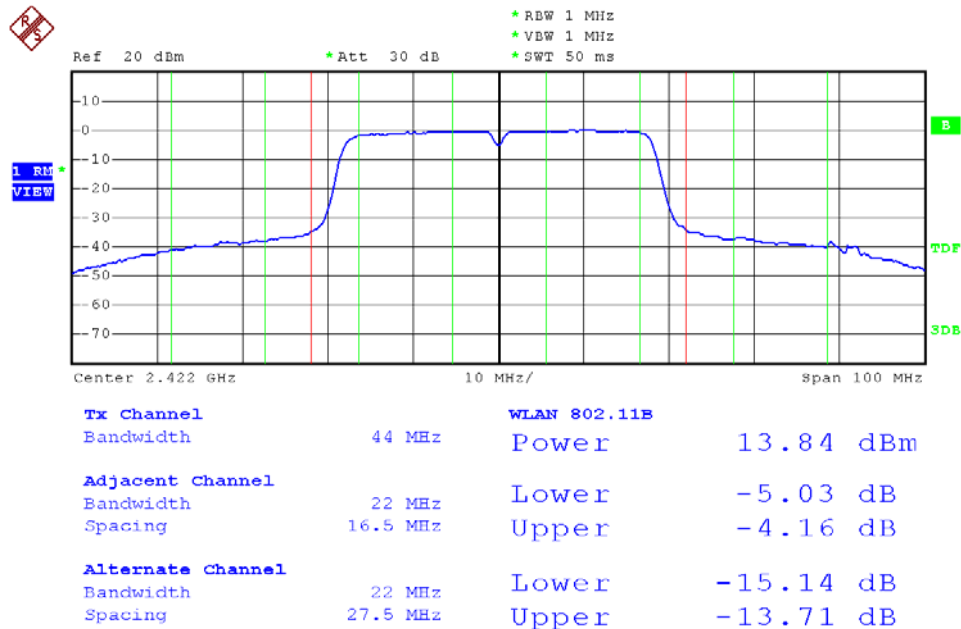



Modulation Standard: 802.11n, HT40 (130Mbps)
Channel: 06

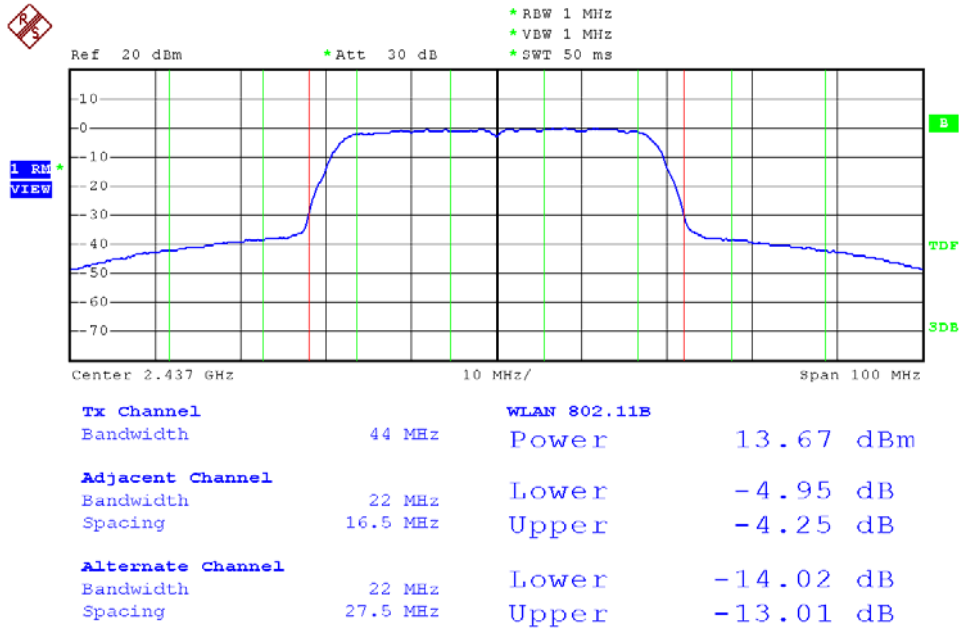

Modulation Standard: 802.11n, HT40 (130Mbps)
Channel: 09

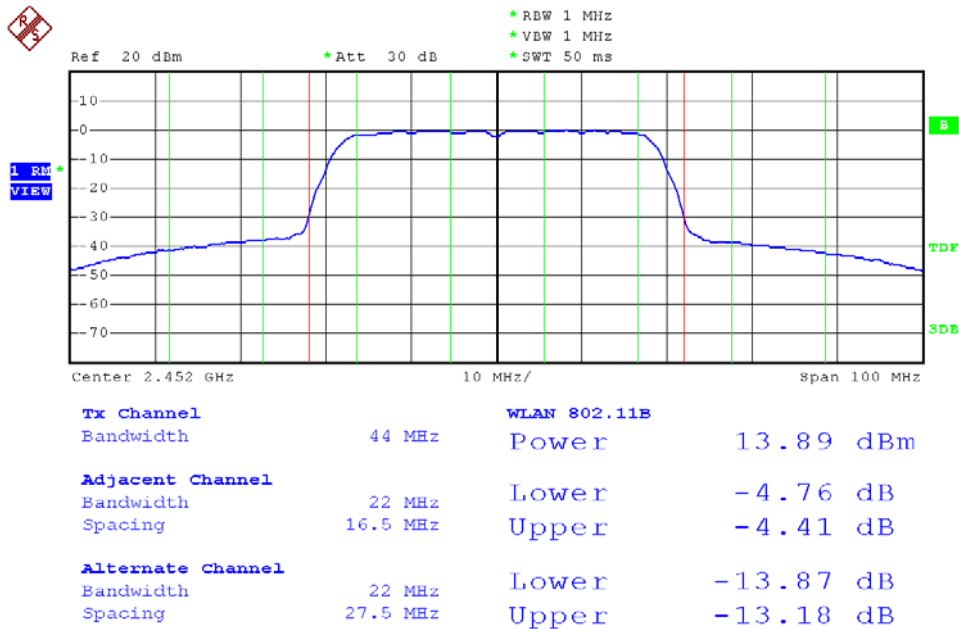



Modulation Standard: 802.11a (54Mbps)
Channel: 149

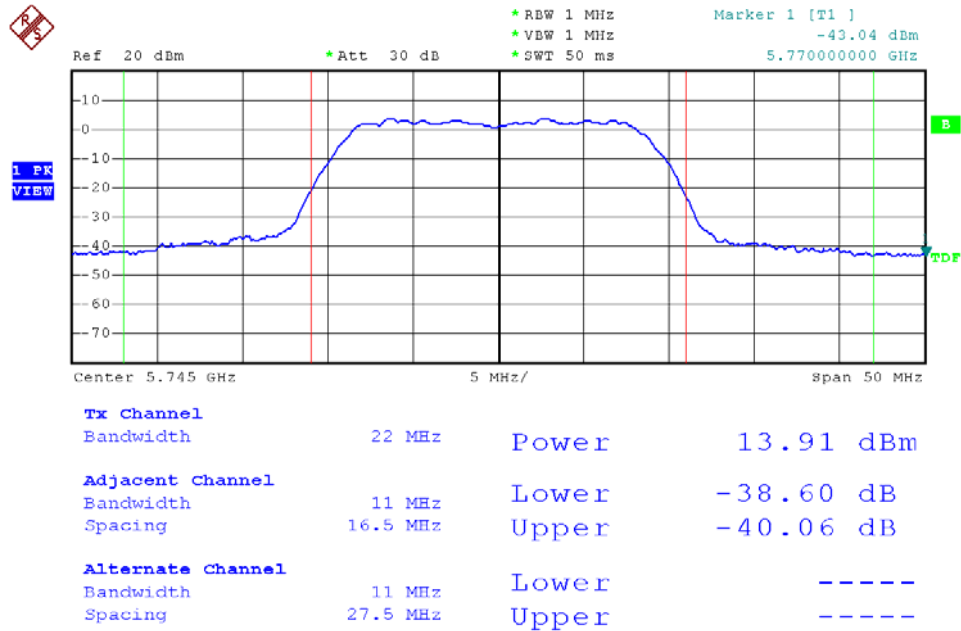

Modulation Standard: 802.11a (54Mbps)
Channel: 157

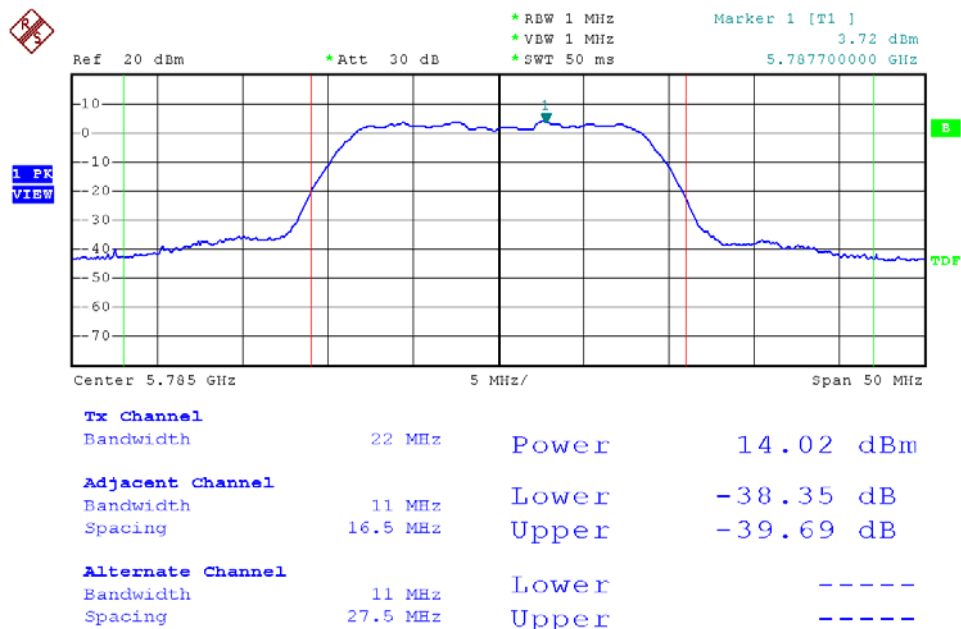



Modulation Standard: 802.11a (54Mbps)
Channel: 165

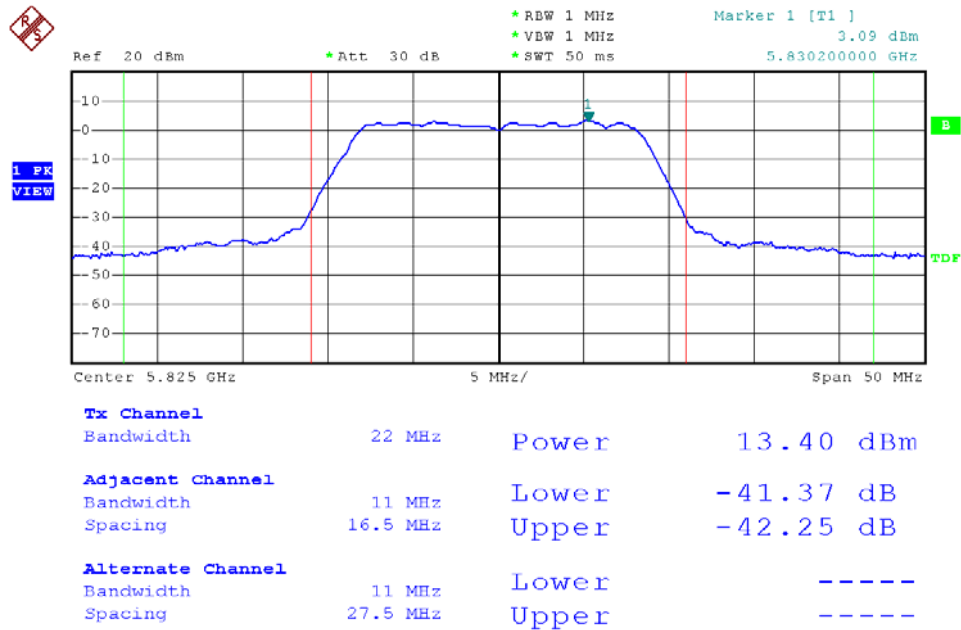

Modulation Standard: 802.11an, HT20 (65Mbps)
Channel: 149

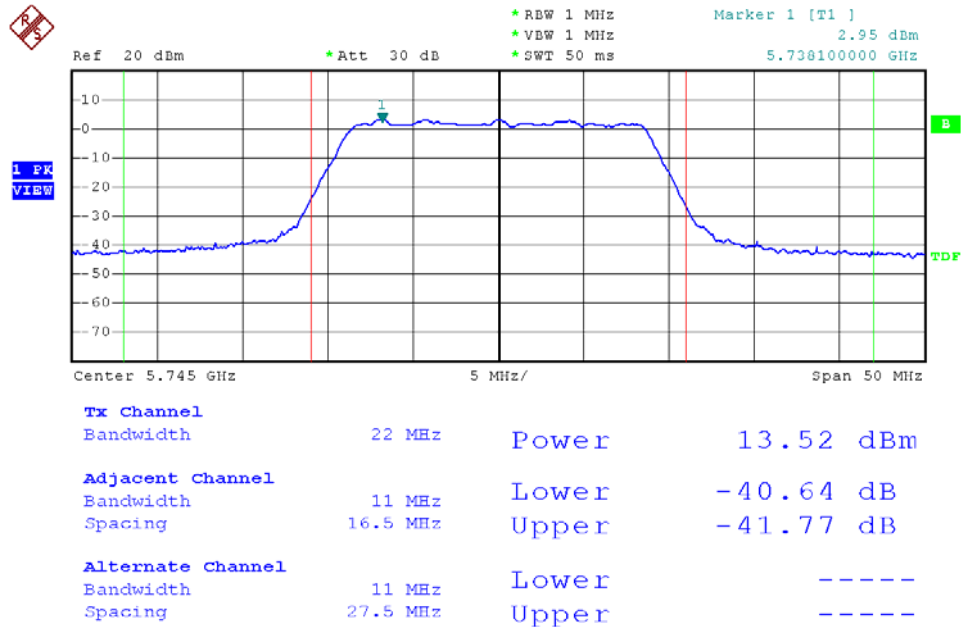



Modulation Standard: 802.11an, HT20 (65Mbps)
Channel: 157

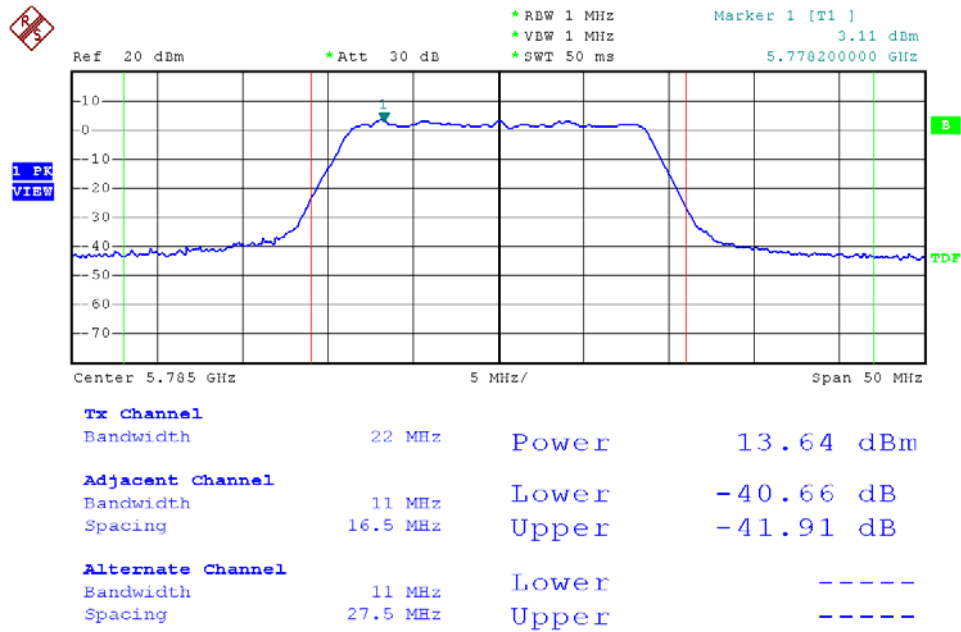

Modulation Standard: 802.11an, HT20 (65Mbps)
Channel: 165

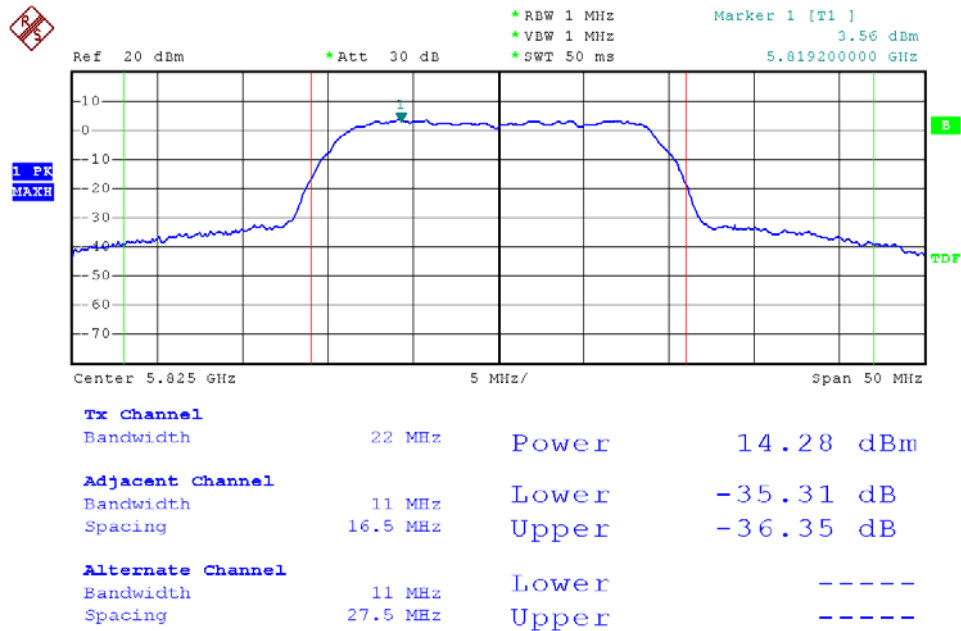



Modulation Standard: 802.11an, HT40 (130Mbps)
Channel: 151

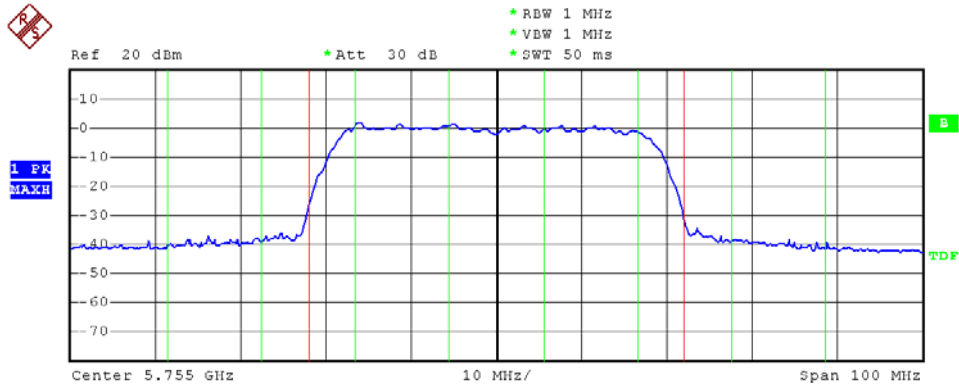

Tx Channel			
Bandwidth	44 MHz	Power	14.68 dBm
Adjacent Channel			
Bandwidth	22 MHz	Lower	-4.18 dB
Spacing	16.5 MHz	Upper	-4.97 dB
Alternate Channel			
Bandwidth	22 MHz	Lower	-12.83 dB
Spacing	27.5 MHz	Upper	-14.44 dB

Modulation Standard: 802.11an, HT40 (130Mbps)
Channel: 159

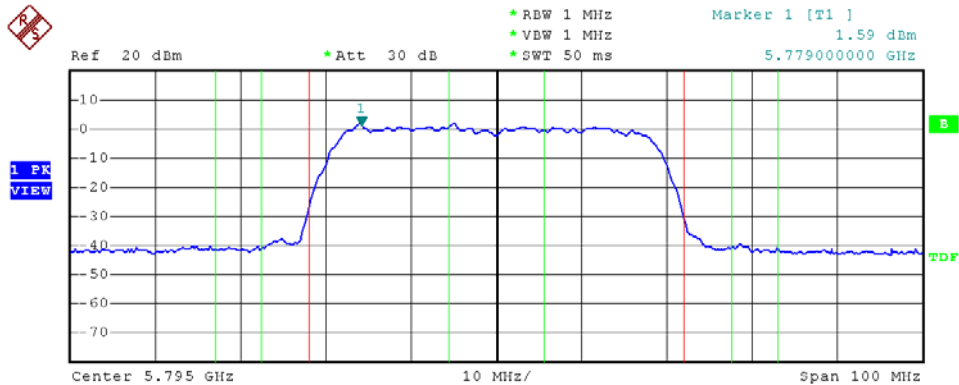

Tx Channel			
Bandwidth	44 MHz	Power	14.72 dBm
Adjacent Channel			
Bandwidth	22 MHz	Lower	-4.26 dB
Spacing	16.5 MHz	Upper	-4.92 dB
Alternate Channel			
Bandwidth	11 MHz	Lower	-43.55 dB
Spacing	27.5 MHz	Upper	-44.16 dB



8. Power Spectral Density

8.1 Test Limit

The Maximum of Power Spectral Density Measurement is 8dBm.

8.2 Test Procedures

- a. The transmitter output was connected to spectrum analyzer.
- b. The spectrum analyzer's resolution bandwidth were set at 3KHz RBW and 30KHz VBW as that of the fundamental frequency. Set the sweep time=span/3KHz.
- c. The power spectral density was measured and recorded.
- d. The Sweep time is allowed to be longer than span/3KHz for a full response of the mixer in the spectrum analyzer.

8.3 Test Setup Layout

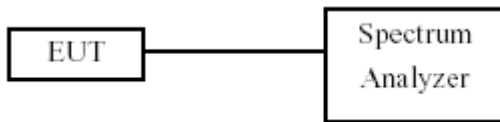

8.4 Measurement Equipment

Instrument/Ancillary	Model No.	Manufacturer	Serial No.	Calibration Date	Valid Date
Spectrum Analyzer	FSP40	R&S	10047	2009/02/21	2010/02/20



8.5 Test Result and Data

Test Date: Jun. 11, 2009

Temperature: 24

Atmospheric pressure: 1013 hPa

Humidity: 66%

Modulation Standard	Channel	Frequency (MHz)	Maximum Power Density of 3 kHz Bandwidth (dBm)
802.11b (11Mbps)	01	2412	-9.57
	06	2437	-9.64
	11	2462	-9.20
802.11g (54Mbps)	01	2412	-14.16
	06	2437	-14.14
	11	2462	-14.36
802.11n HT20 (65Mbps)	01	2412	-15.22
	06	2437	-15.00
	11	2462	-15.84
802.11n HT40 (130Mbps)	03	2422	-17.80
	06	2437	-17.50
	09	2452	-17.54

Test Date: Jun. 10, 2009

Temperature: 26

Atmospheric pressure: 1012 hPa

Humidity: 64%

Modulation Standard	Channel	Frequency (MHz)	Maximum Power Density of 3 kHz Bandwidth (dBm)
802.11a (54Mbps)	149	5745	-21.82
	157	5785	-22.28
	165	5825	-22.06
802.11an HT20 (65Mbps)	149	5745	-22.45
	157	5785	-23.21
	165	5825	-22.85
802.11an HT40 (130Mbps)	151	5755	-24.58
	155	5775	-----
	159	5795	-22.67



Modulation Standard: 802.11b (11Mbps)
Channel: 01

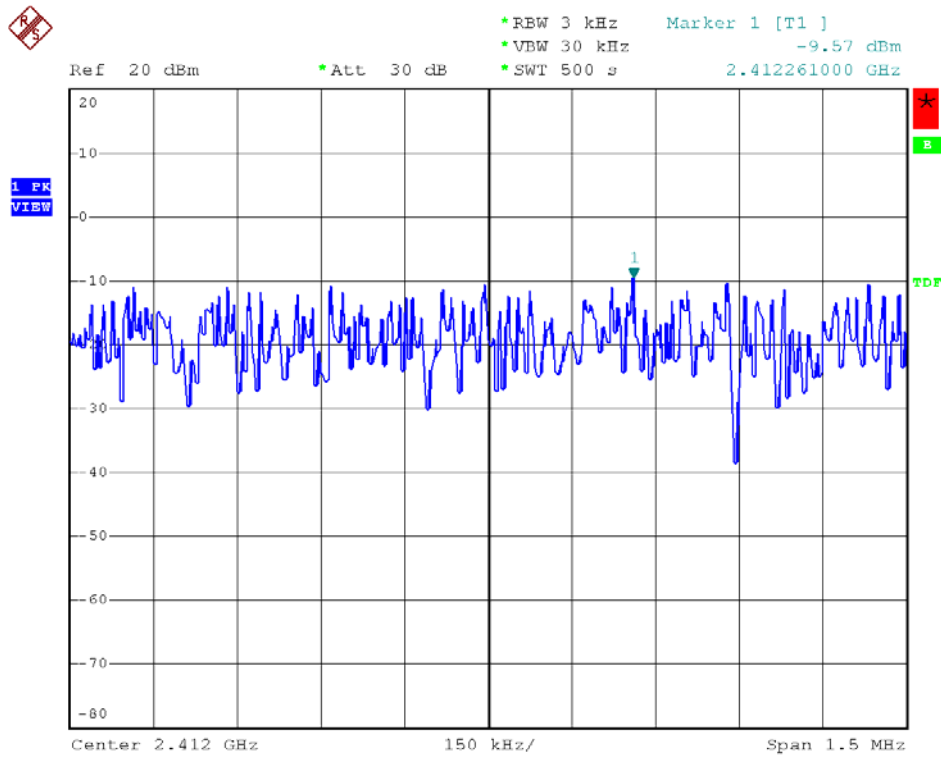

Modulation Standard: 802.11b (11Mbps)
Channel: 06

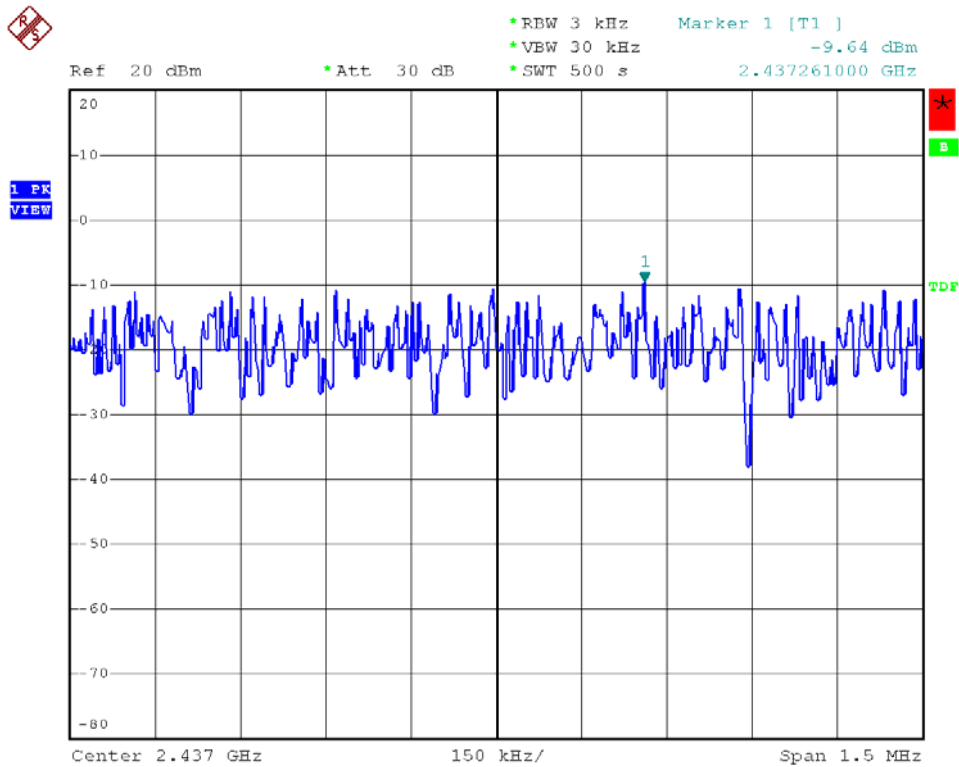



Modulation Standard: 802.11b (11Mbps)
Channel: 11

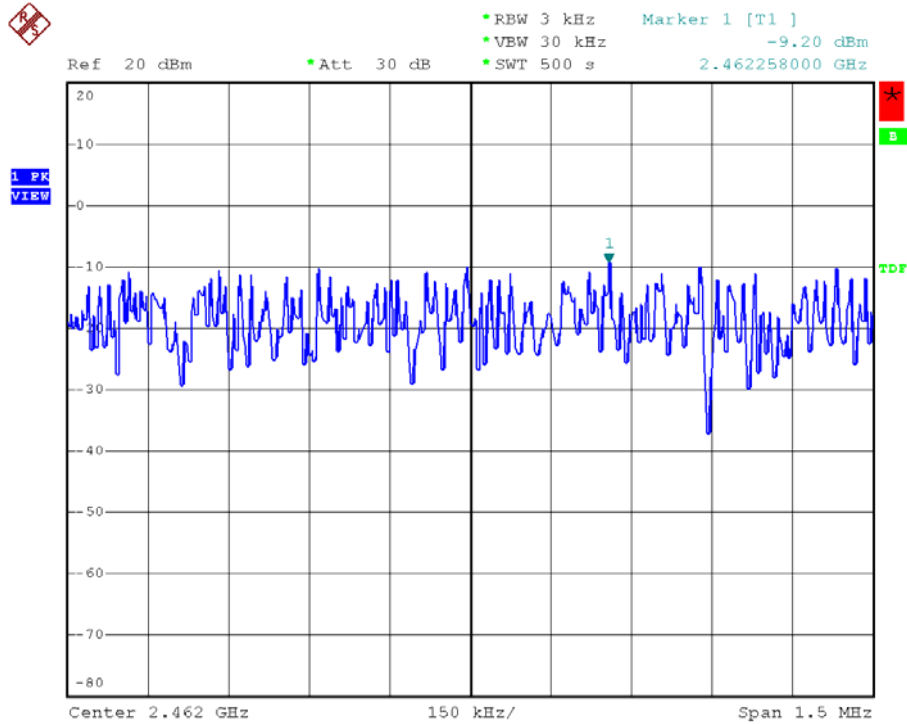

Modulation Standard: 802.11g (54Mbps)
Channel: 01

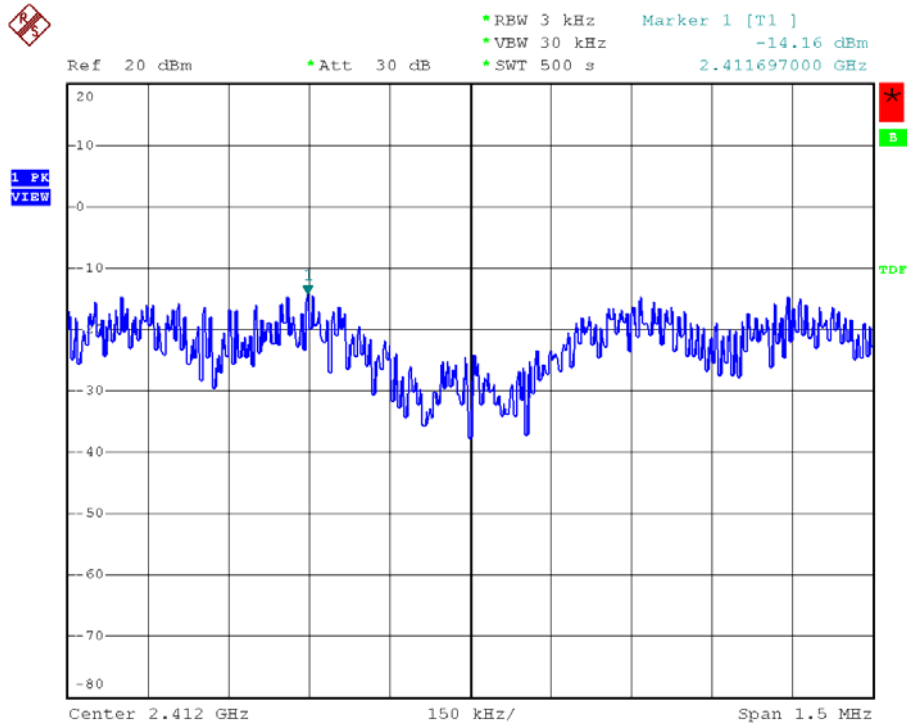



Modulation Standard: 802.11g (54Mbps)
Channel: 06

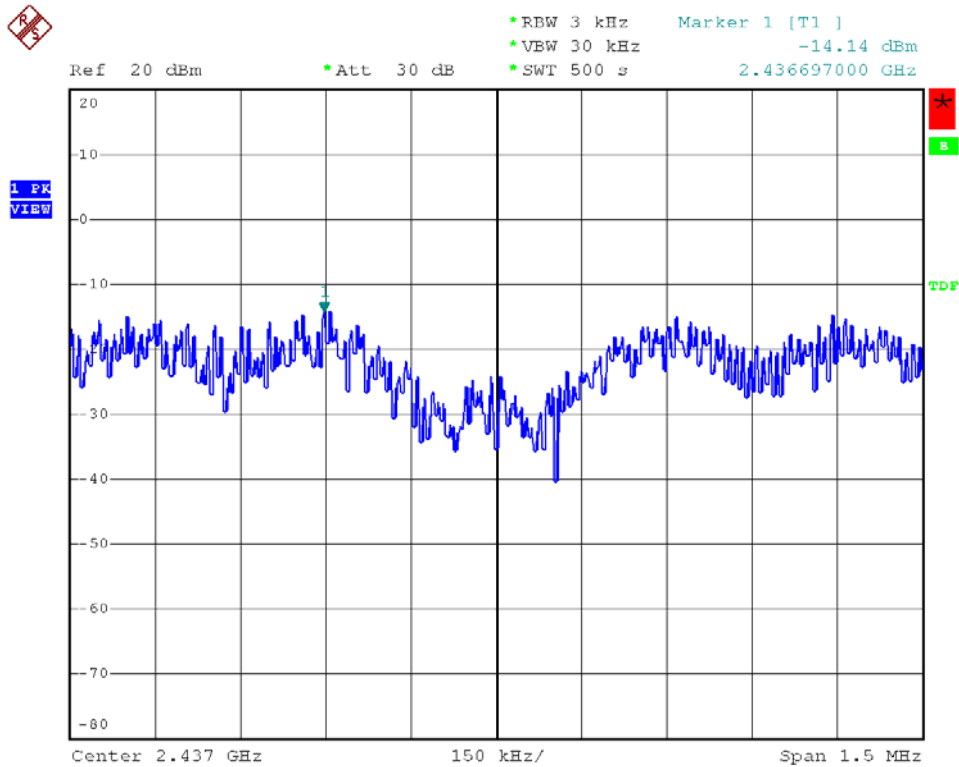

Modulation Standard: 802.11g (54Mbps)
Channel: 11

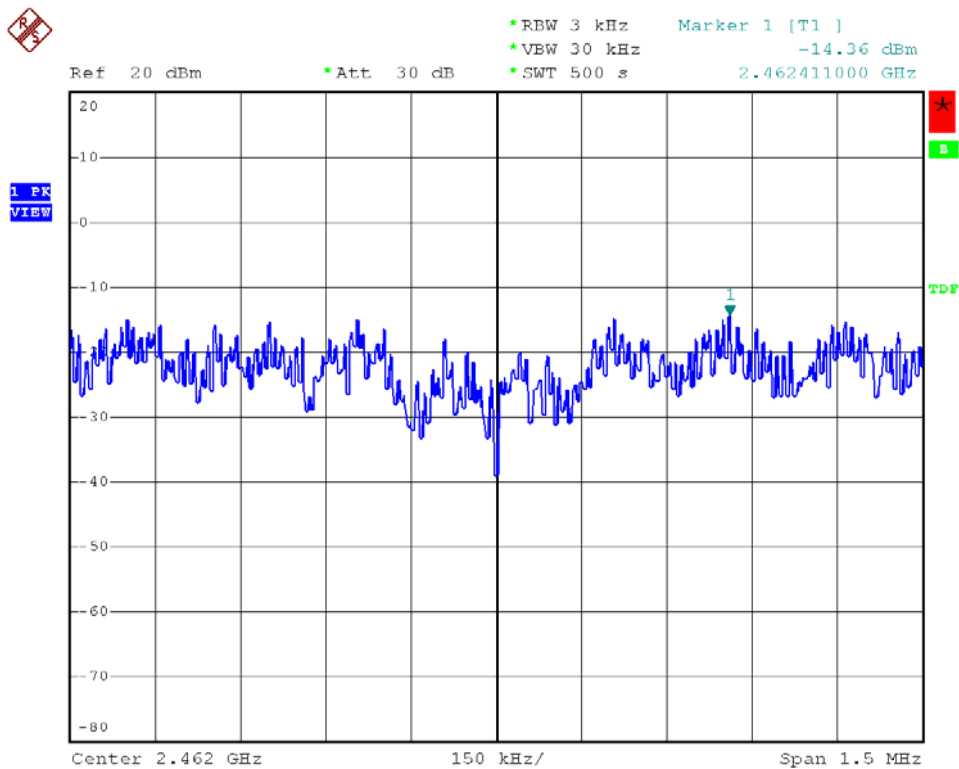



Modulation Standard: 802.11n, HT20 (65Mbps)
Channel: 01

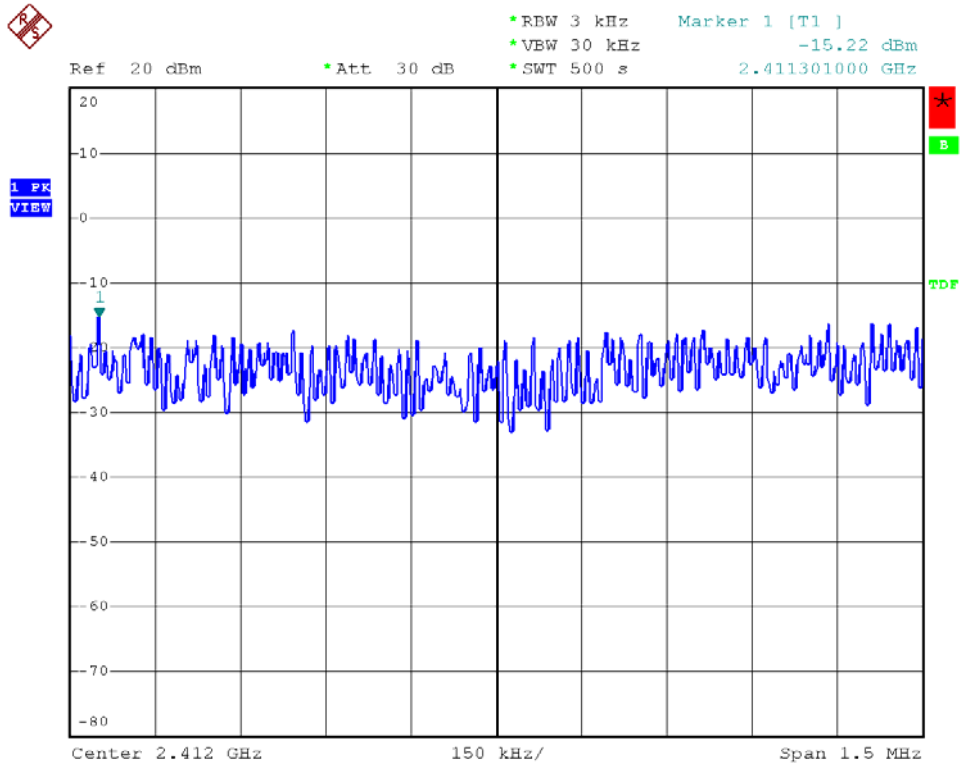

Modulation Standard: 802.11n, HT20 (65Mbps)
Channel: 06

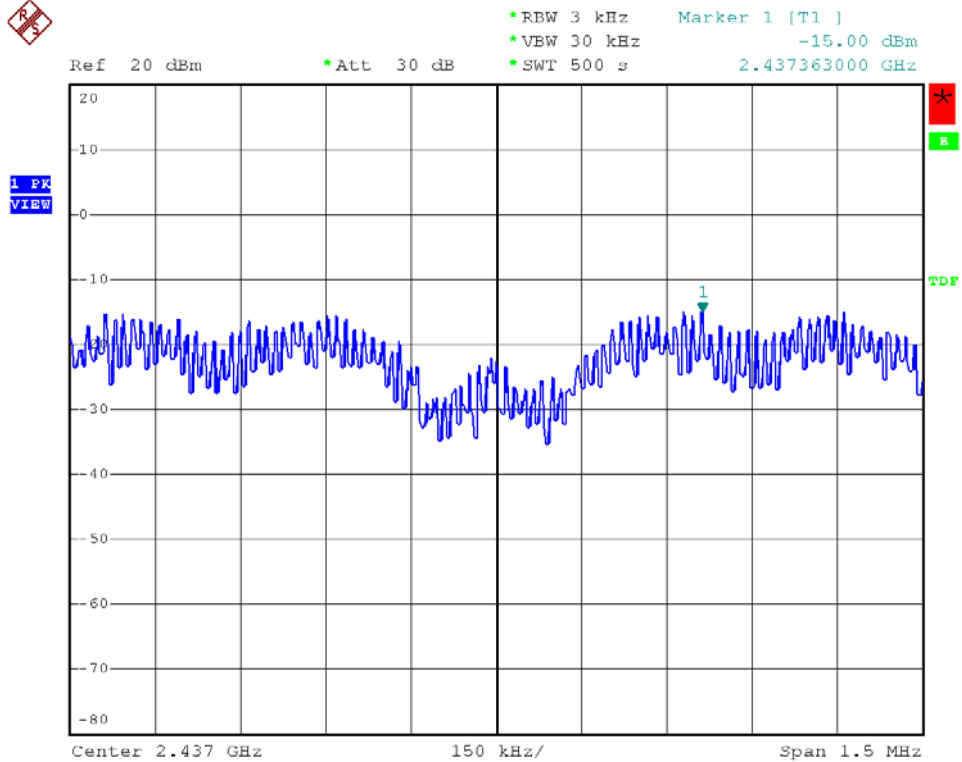



Modulation Standard: 802.11n, HT20 (65Mbps)
Channel: 11

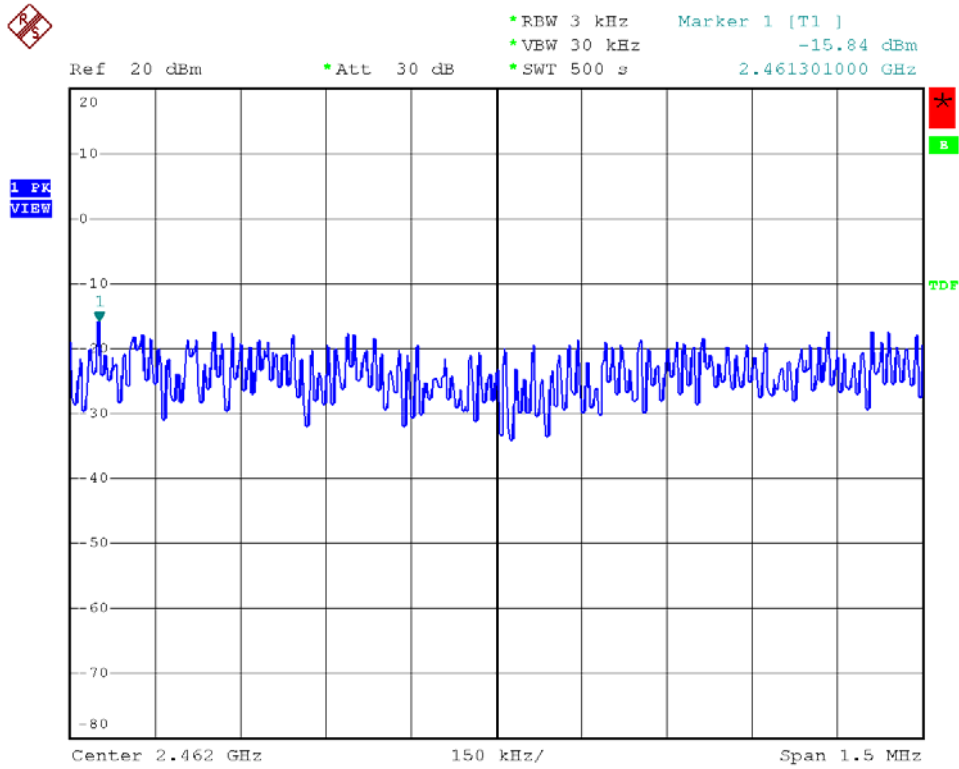

Modulation Standard: 802.11n, HT40 (130Mbps)
Channel: 03

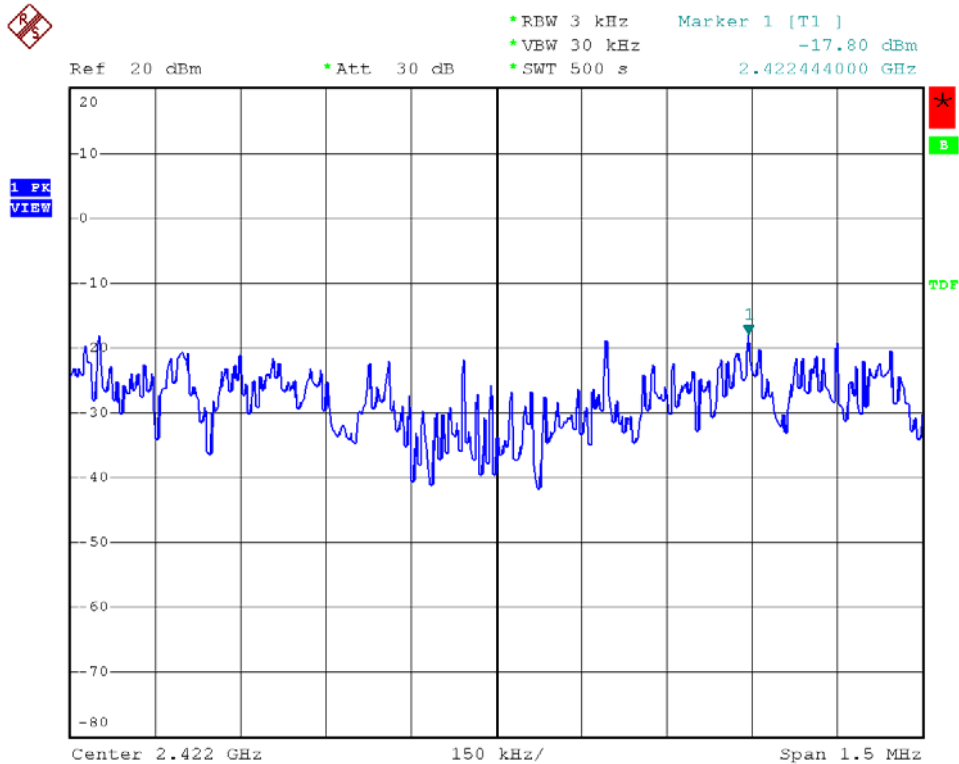



Modulation Standard: 802.11n, HT40 (130Mbps)
Channel: 06

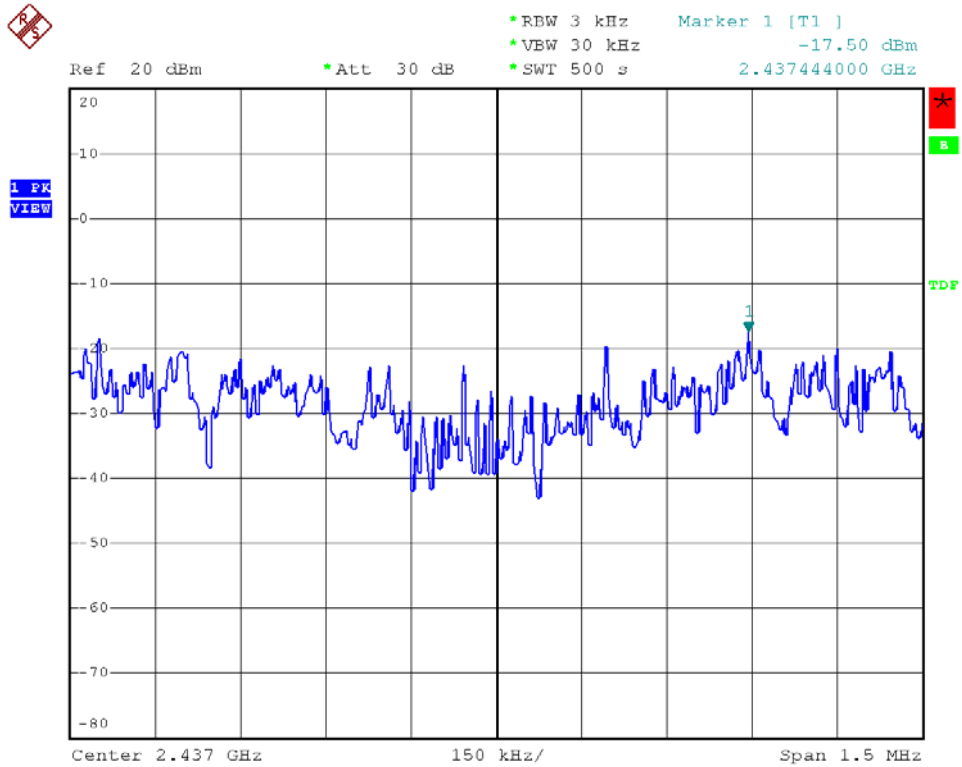

Modulation Standard: 802.11n, HT40 (130Mbps)
Channel: 09

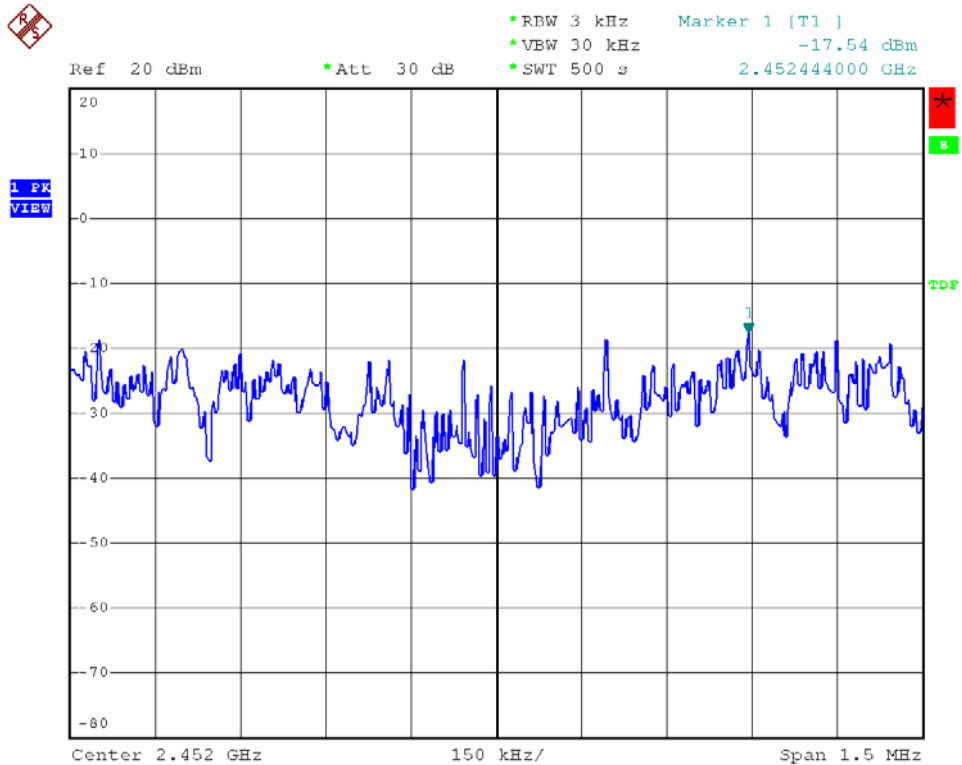



Modulation Standard: 802.11a (54Mbps)
Channel: 149

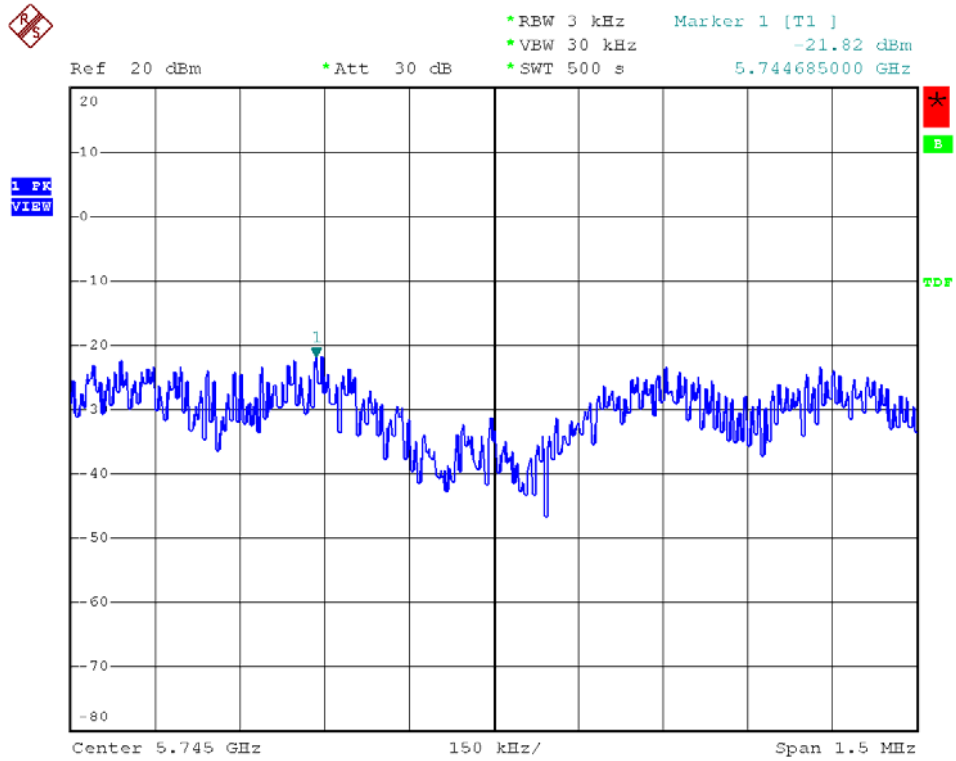

Modulation Standard: 802.11a (54Mbps)
Channel: 157

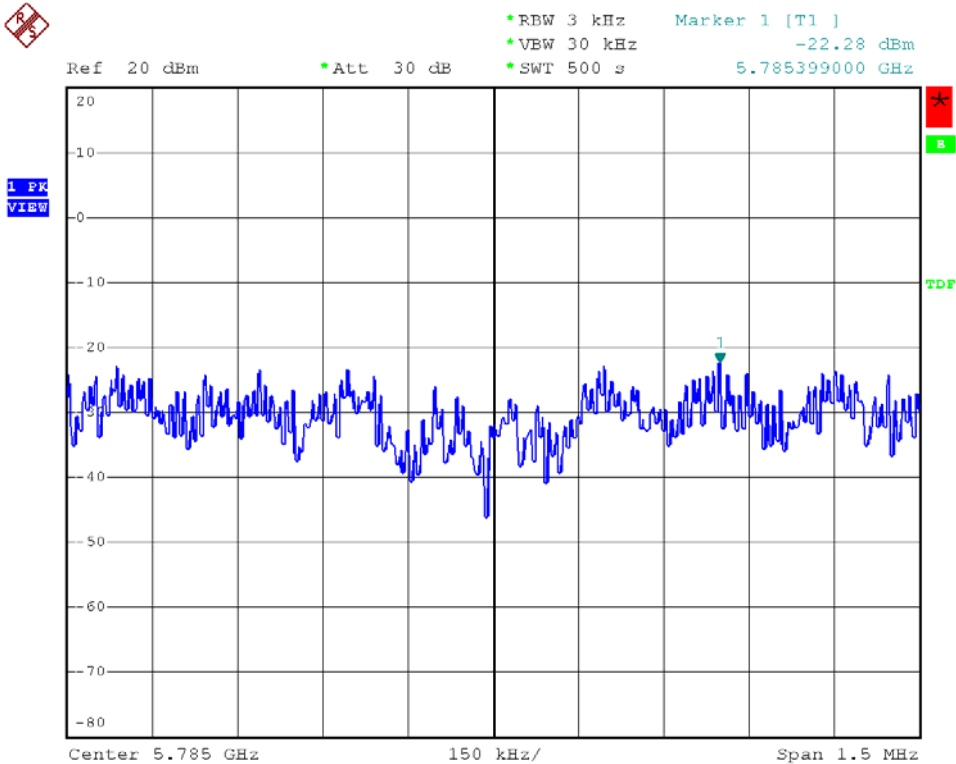



Modulation Standard: 802.11a (54Mbps)
Channel: 165

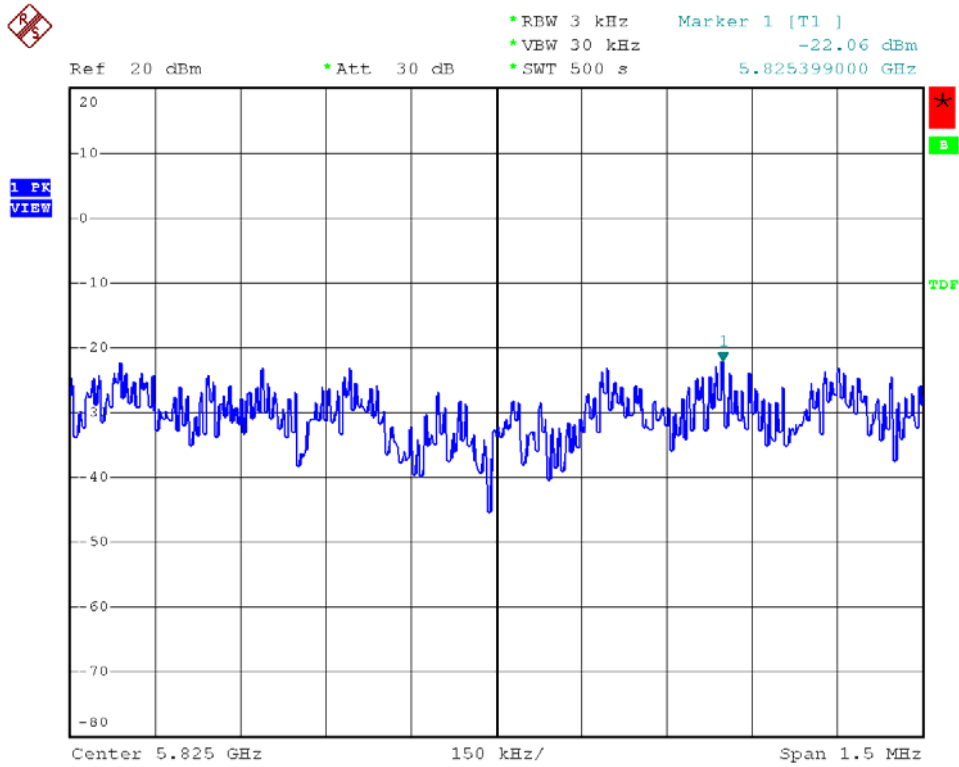

Modulation Standard: 802.11an, HT20 (65Mbps)
Channel: 149

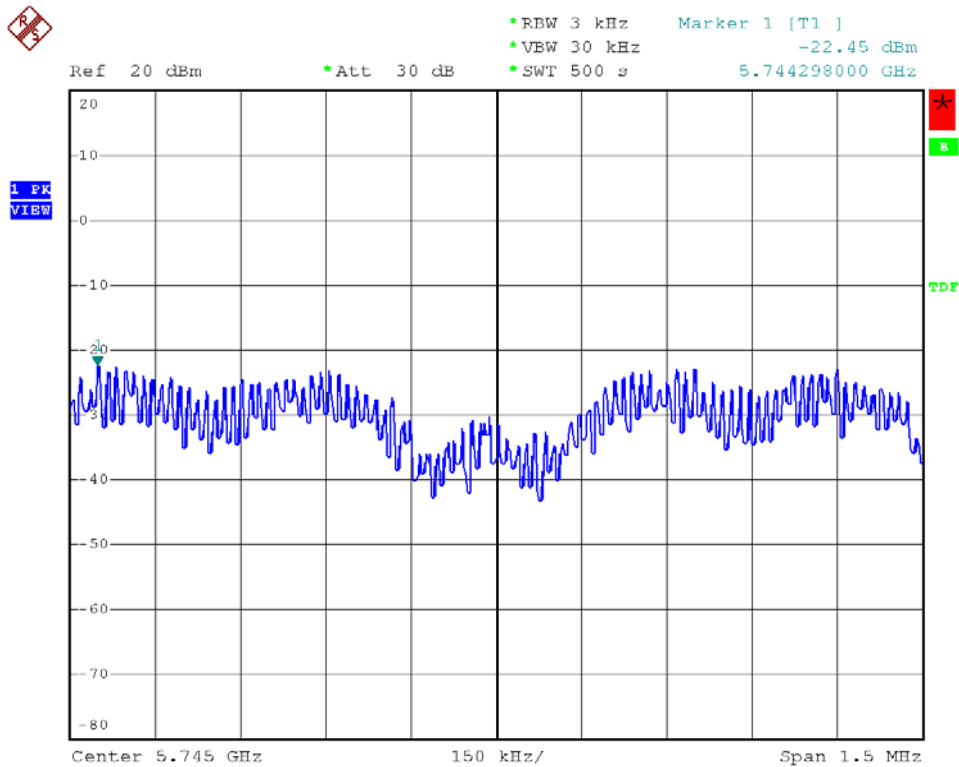



Modulation Standard: 802.11an, HT20 (65Mbps)
Channel: 157

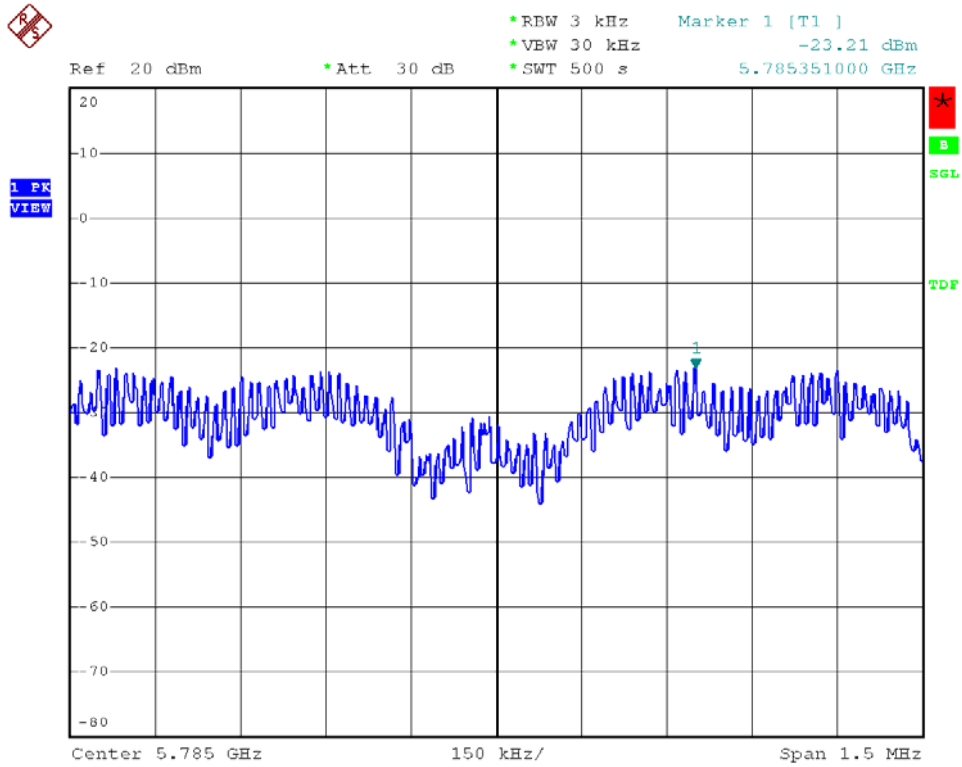

Modulation Standard: 802.11an, HT20 (65Mbps)
Channel: 165

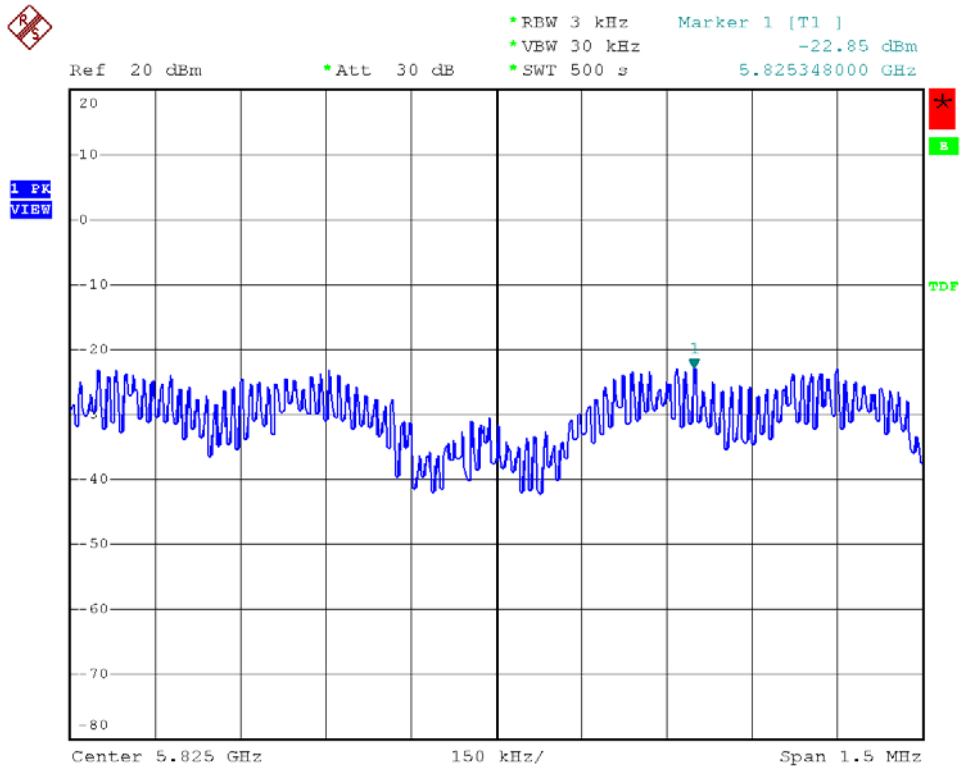



Modulation Standard: 802.11an, HT40 (130Mbps)
Channel: 151

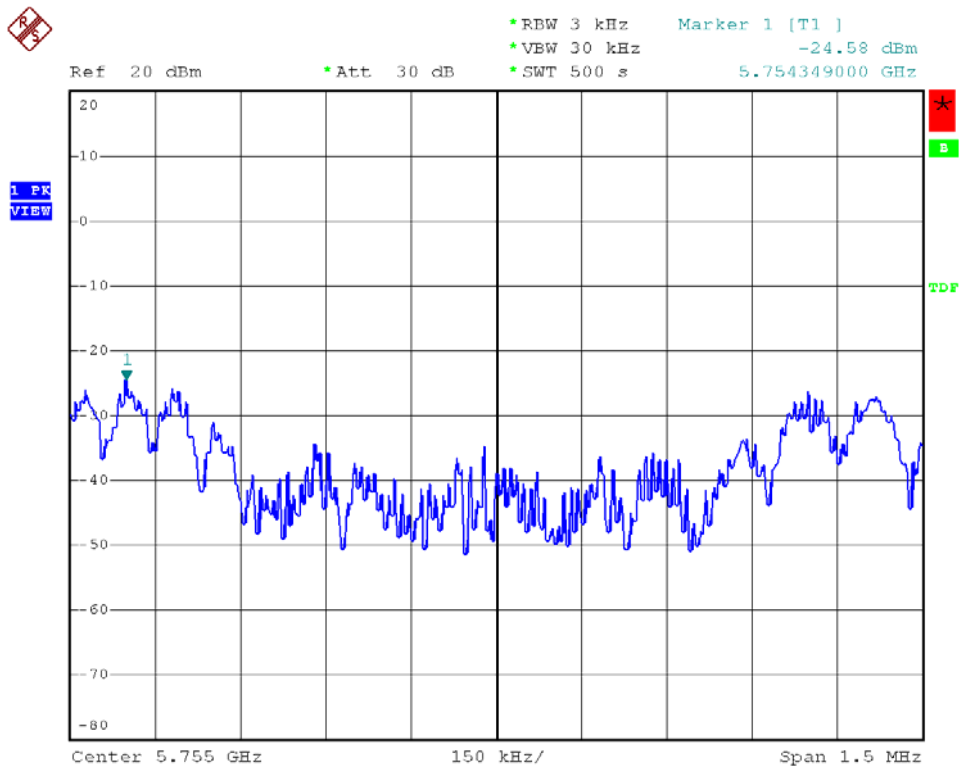

Modulation Standard: 802.11an, HT40 (130Mbps)
Channel: 159

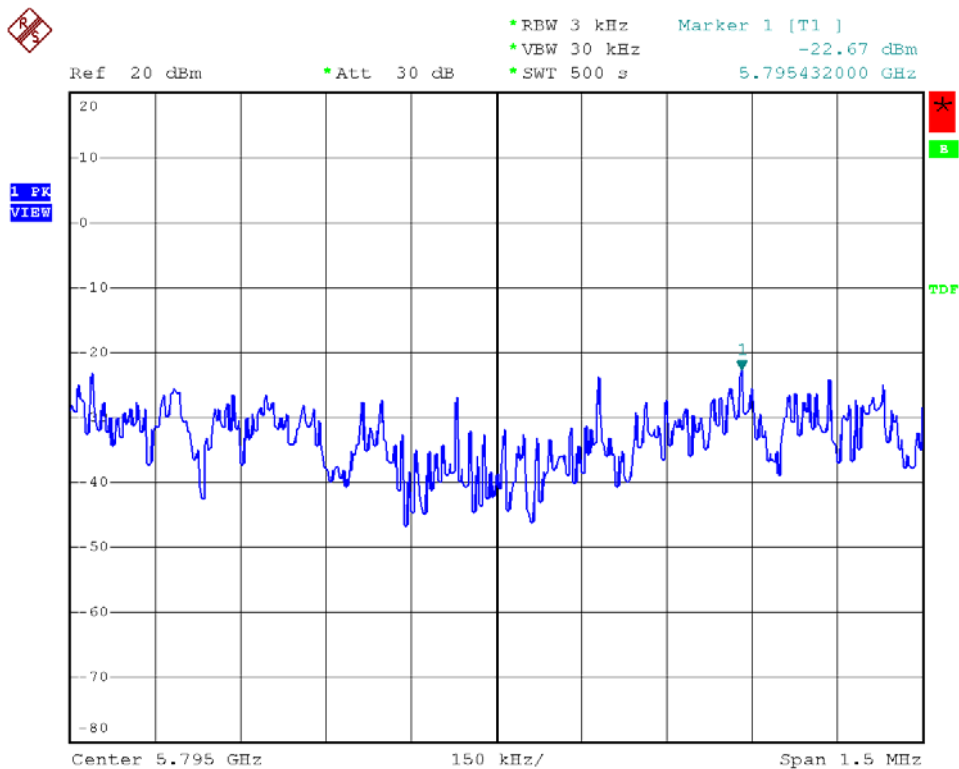



9. Band Edges Measurement

9.1 Test Limit

Below -20dB of the highest emission level of operating band (In 100 kHz Resolution Bandwidth)

9.2 Test Procedure

- a. The transmitter output was connected to the spectrum analyzer via a low lose cable.
- b. Set both RBW and VBW of spectrum analyzer to 100 KHz with convenient frequency span including 100 KHz bandwidth from band edge.
- c. The band edges was measured and recorded.

9.3 Test Setup Layout

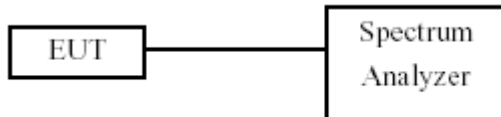

9.4 Measurement Equipment

Instrument/Ancillary	Model No.	Manufacturer	Serial No.	Calibration Date	Valid Date
Spectrum Analyzer	FSP40	R&S	10047	2009/02/21	2010/02/20



9.5 Test Result and Data

Test Date: Jun. 10, 2009

Temperature: 26

Atmospheric pressure: 1012 hPa

Humidity: 64%

Modulation Standard	Channel	Frequency (MHz)	maximum value in frequency (MHz)	maximum value (dBm)
802.11b (11Mbps)	01	2412	2399.2	-34.73
	11	2462	2487.1	-45.30
802.11g (54Mbps)	01	2412	2399.8	-33.19
	11	2462	2483.7	-42.48
802.11n HT20 (65Mbps)	01	2412	2399.8	-35.05
	11	2462	2484.3	-44.56
802.11n HT40 (130Mbps)	03	2422	2396.2	-36.01
	09	2452	2485.5	-40.49

Test Date: Jun. 10, 2009

Temperature: 26

Atmospheric pressure: 1012 hPa

Humidity: 64%

Modulation Standard	Channel	Frequency (MHz)	maximum value in frequency (MHz)	maximum value (dBm)
802.11a (54Mbps)	149	5745	40000.00	-46.32
	165	5825	40000.00	-45.85
802.11an HT20 (65Mbps)	149	5745	40000.00	-46.71
	165	5825	40000.00	-45.06
802.11an HT40 (130Mbps)	151	5755	40000.00	-45.63
	159	5795	39932.00	-45.88



Modulation Standard: 802.11b (11Mbps)
Channel: 01

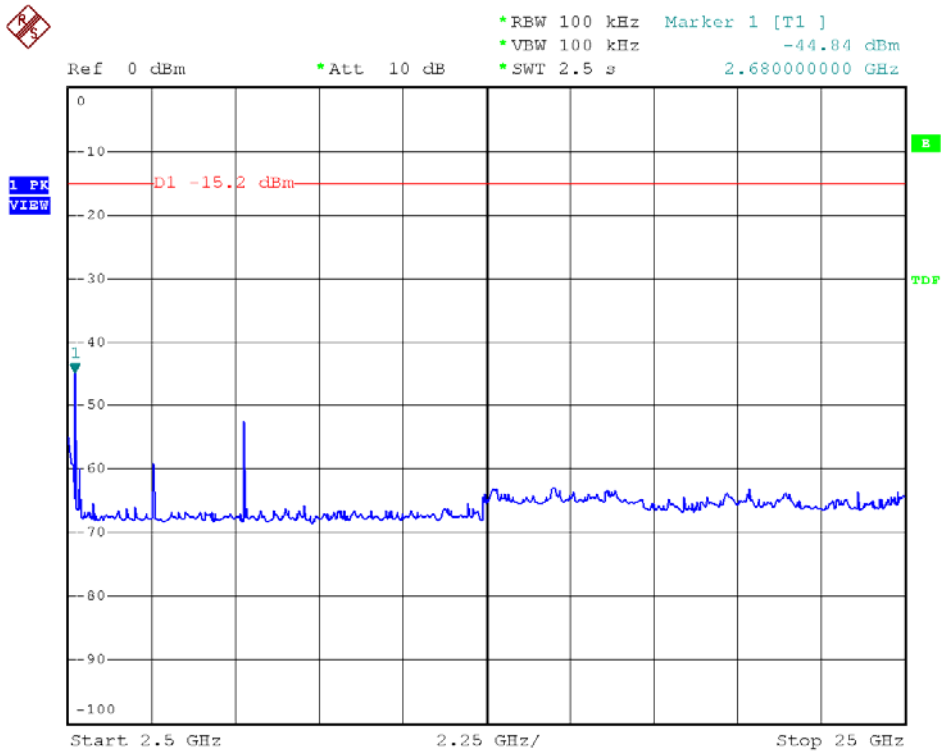
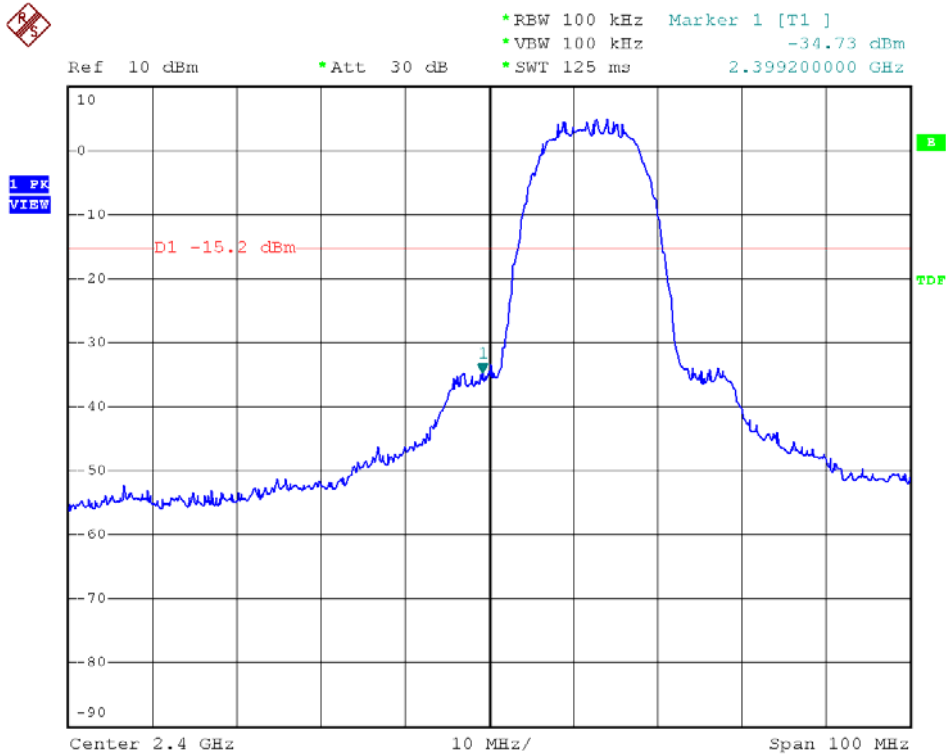



Modulation Standard: 802.11b (11Mbps)
Channel: 11

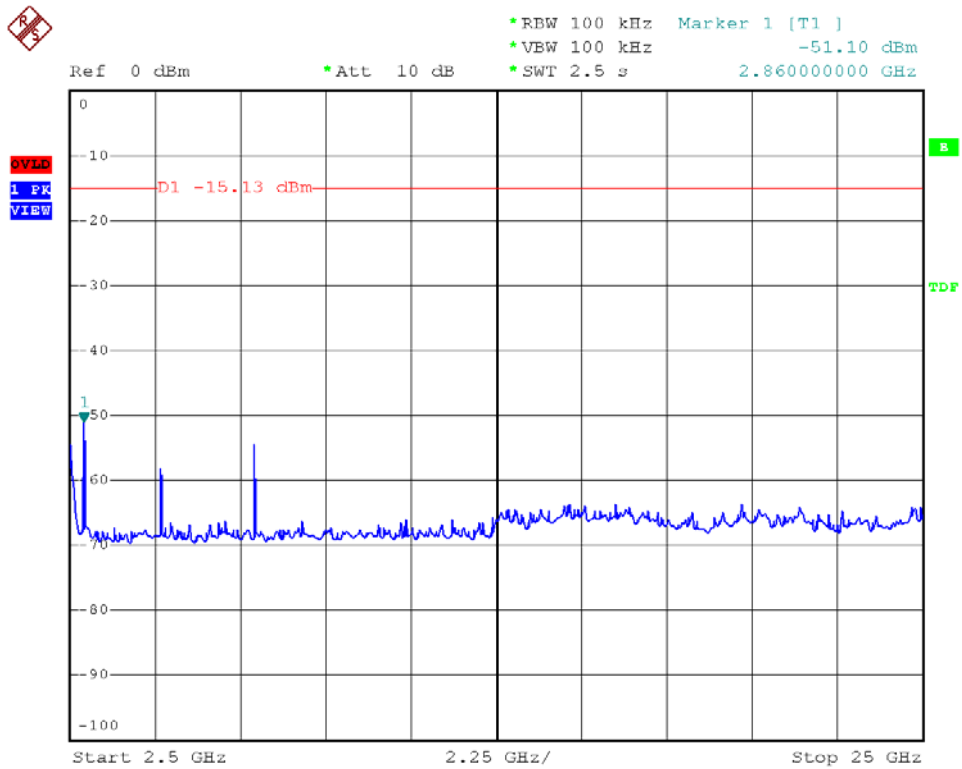
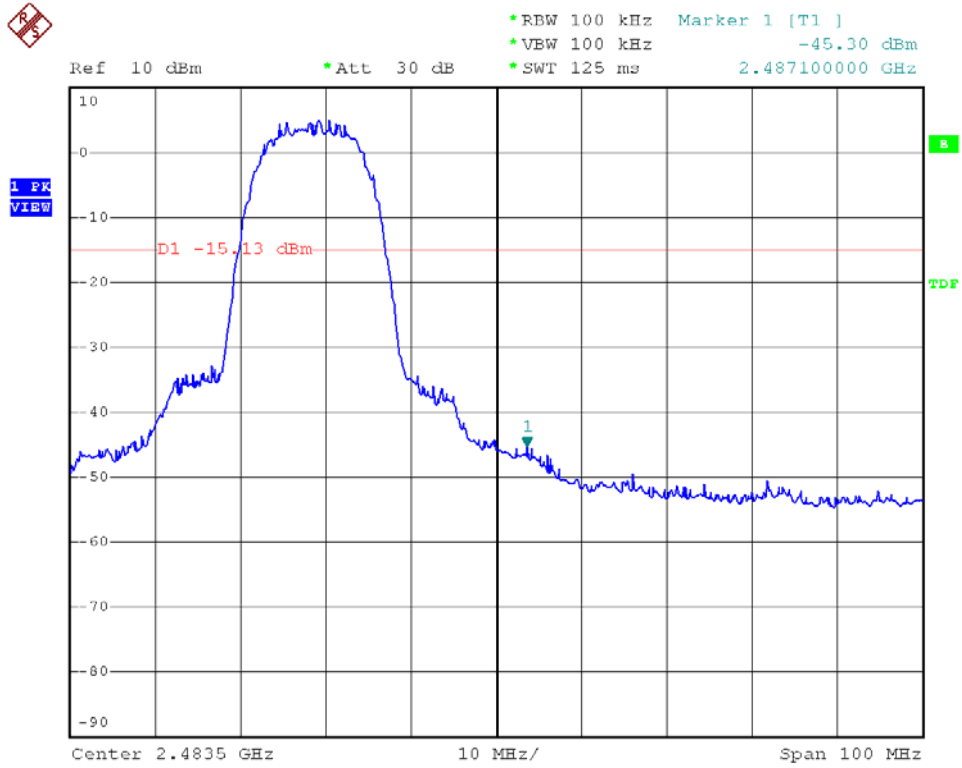



Modulation Standard: 802.11g (54Mbps)
Channel: 01

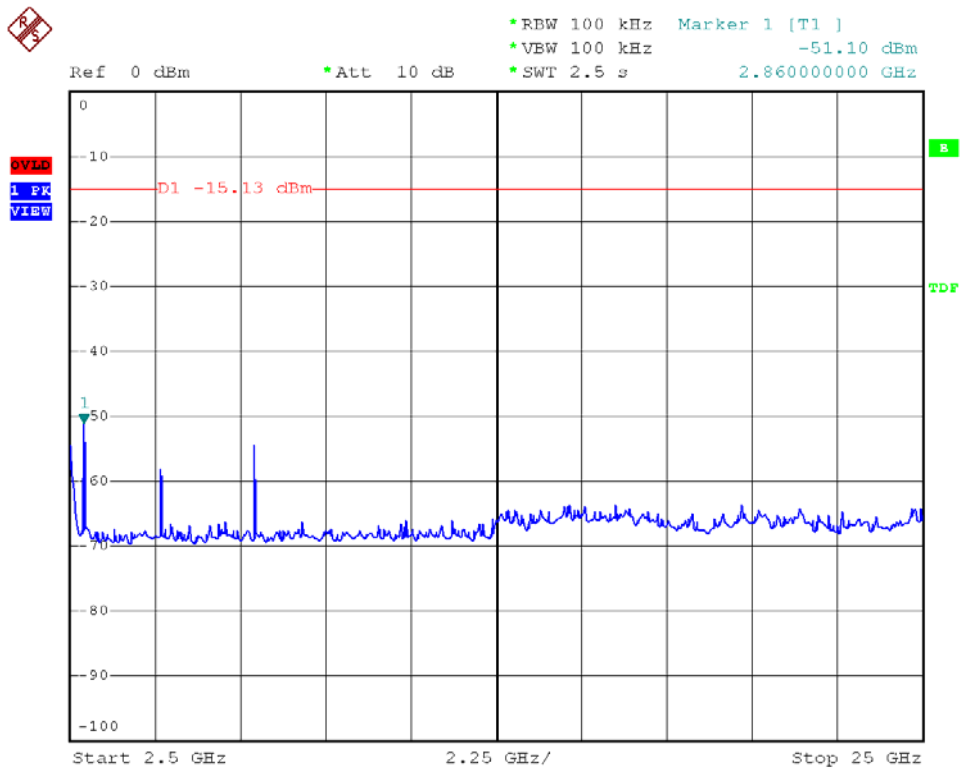
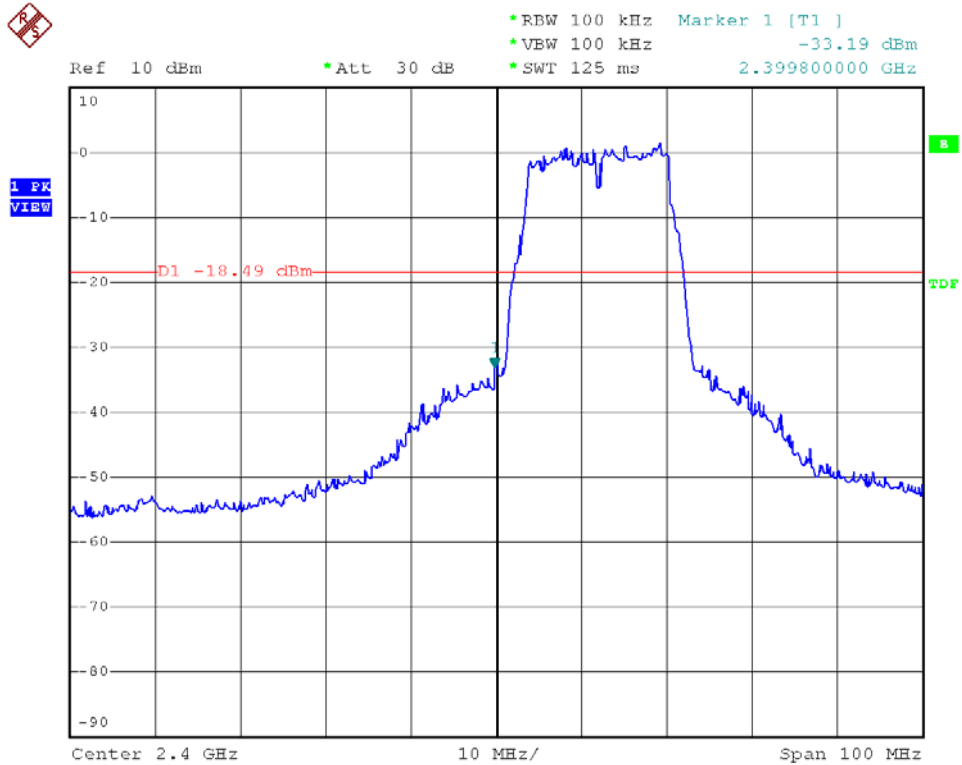



Modulation Standard: 802.11g (54Mbps)
Channel: 11

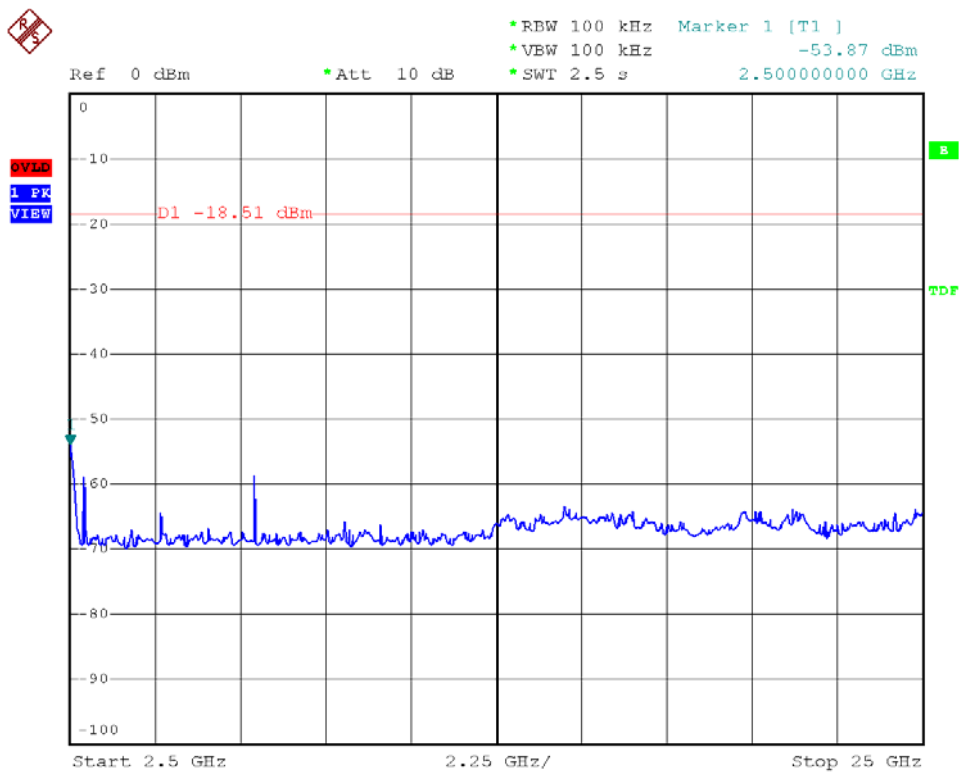
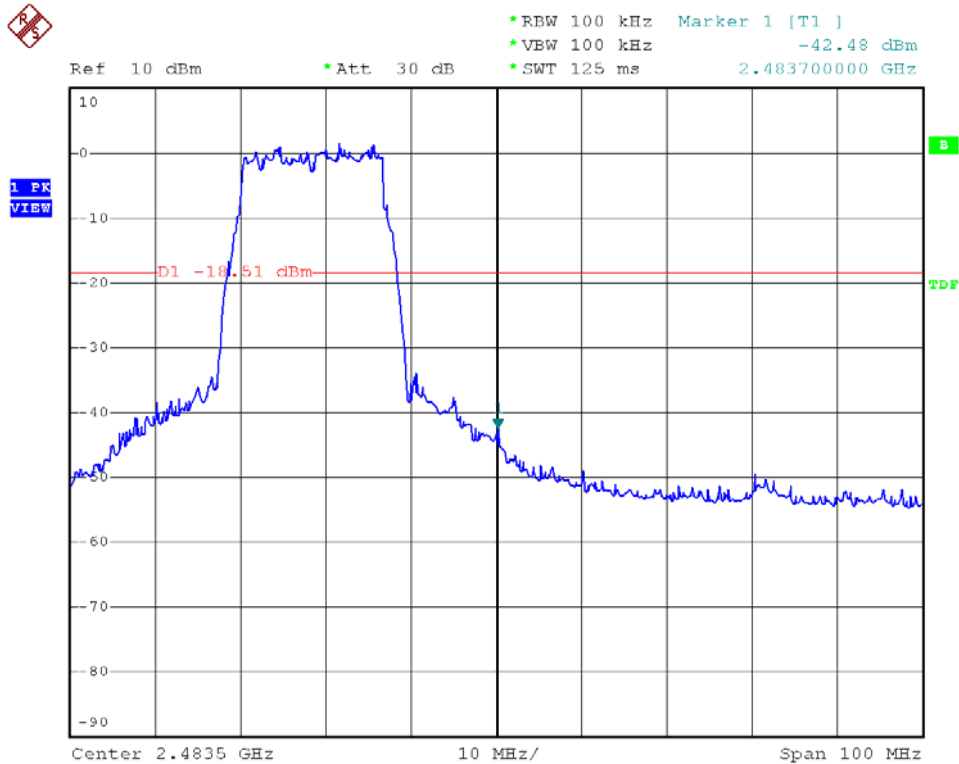



Modulation Standard: 802.11n, HT20 (65Mbps)
Channel: 01

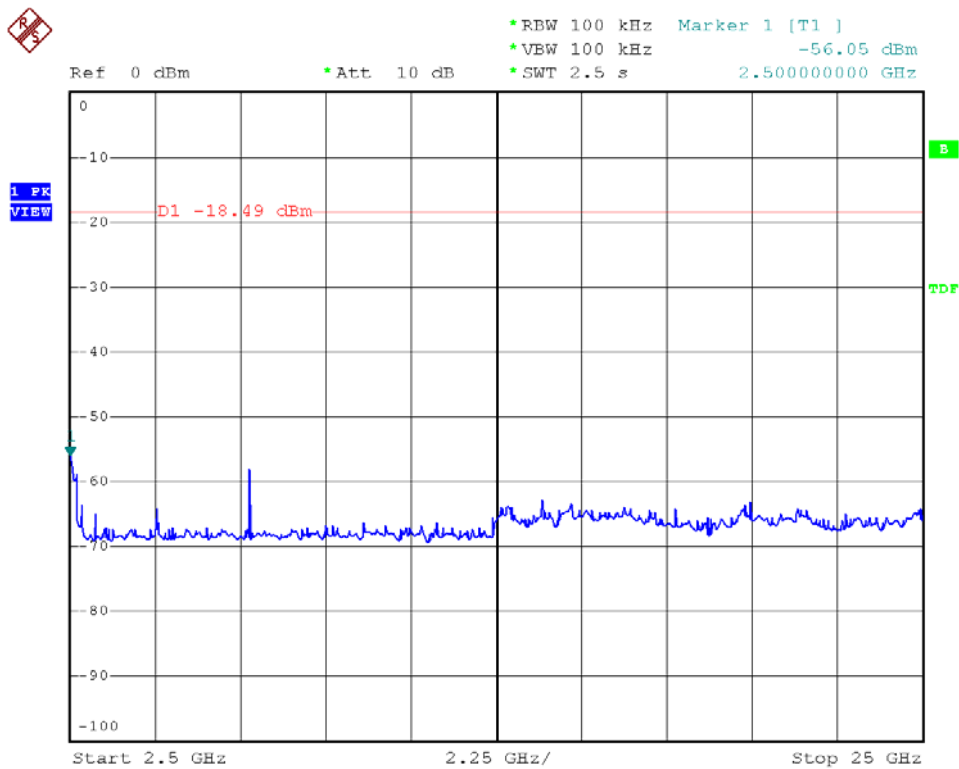
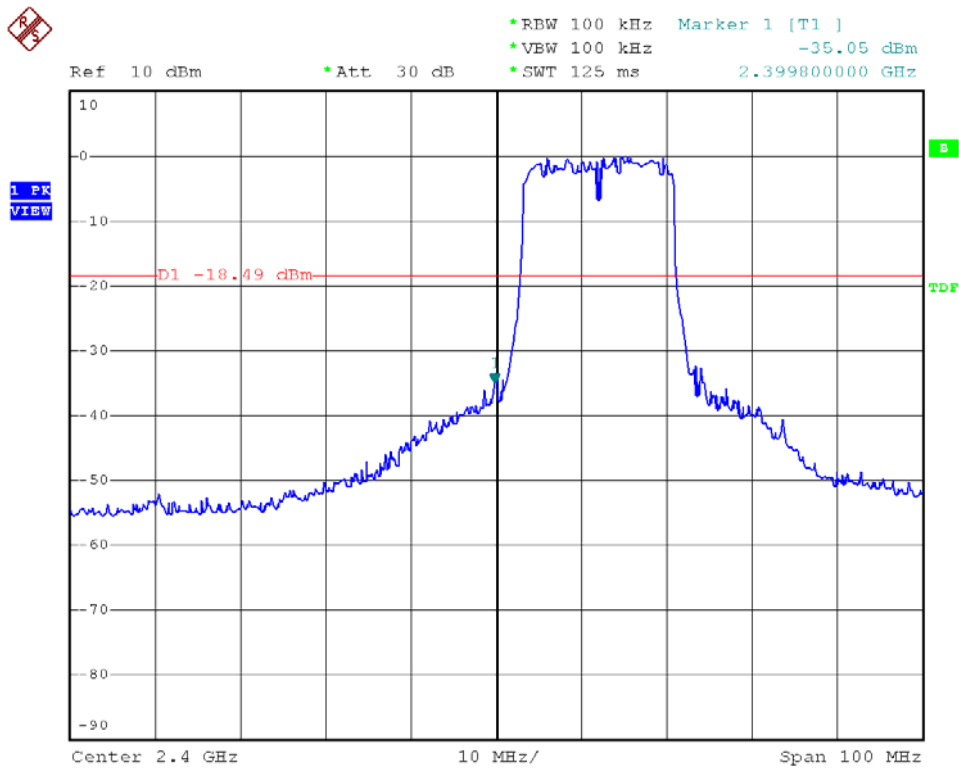



Modulation Standard: 802.11n, HT20 (65Mbps)
Channel: 11

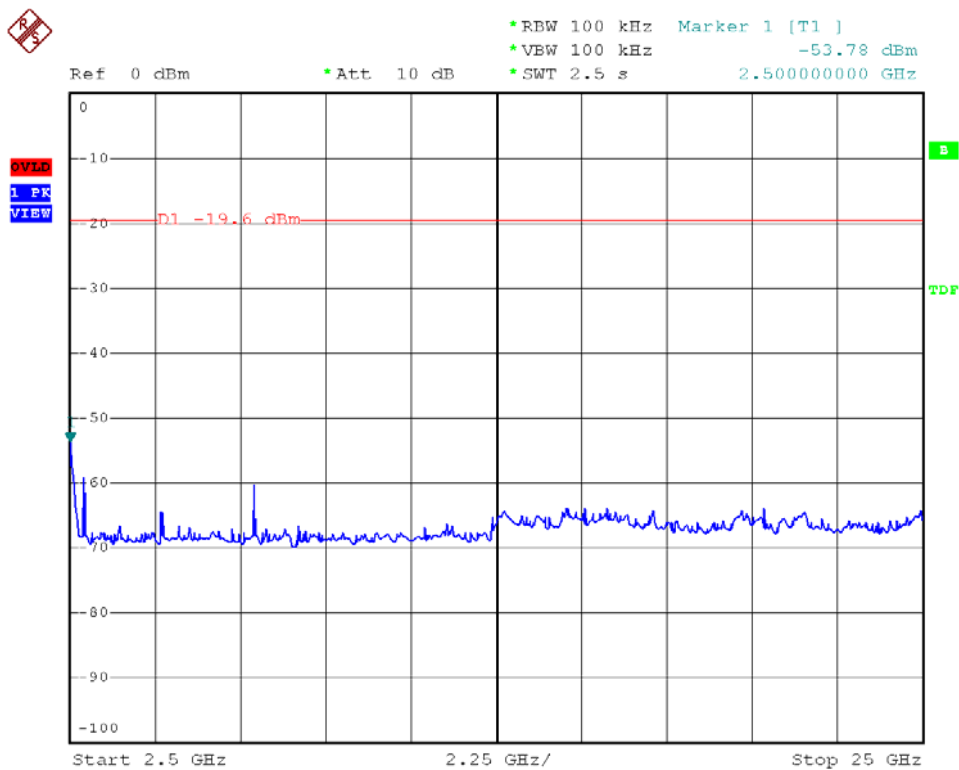
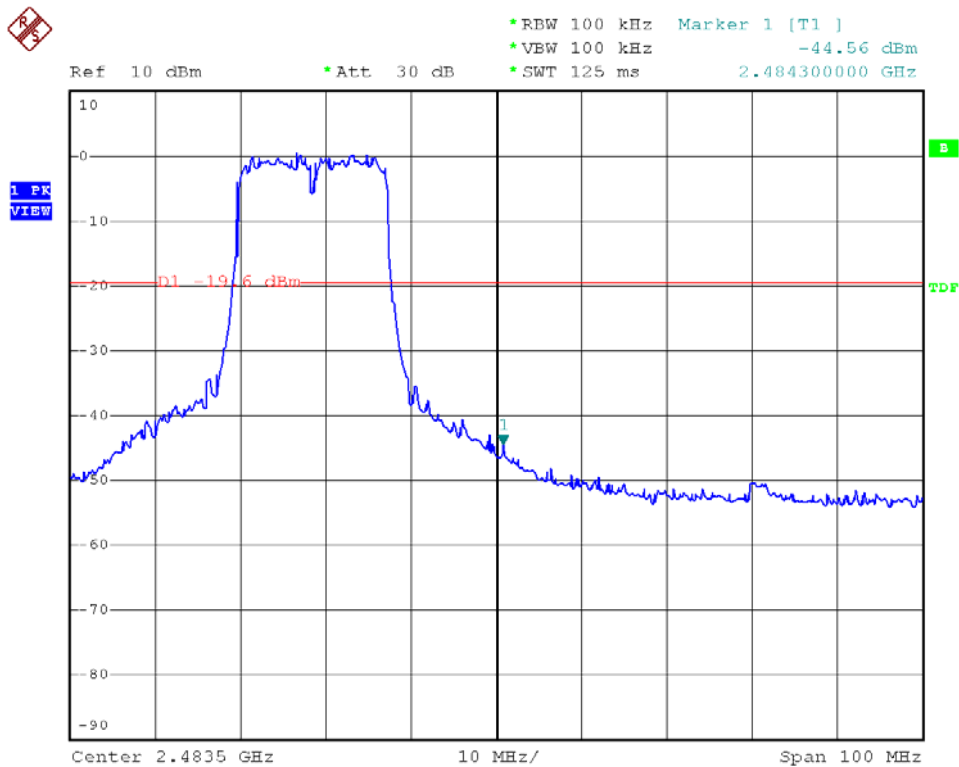



Modulation Standard: 802.11n, HT40 (130Mbps)
Channel: 03

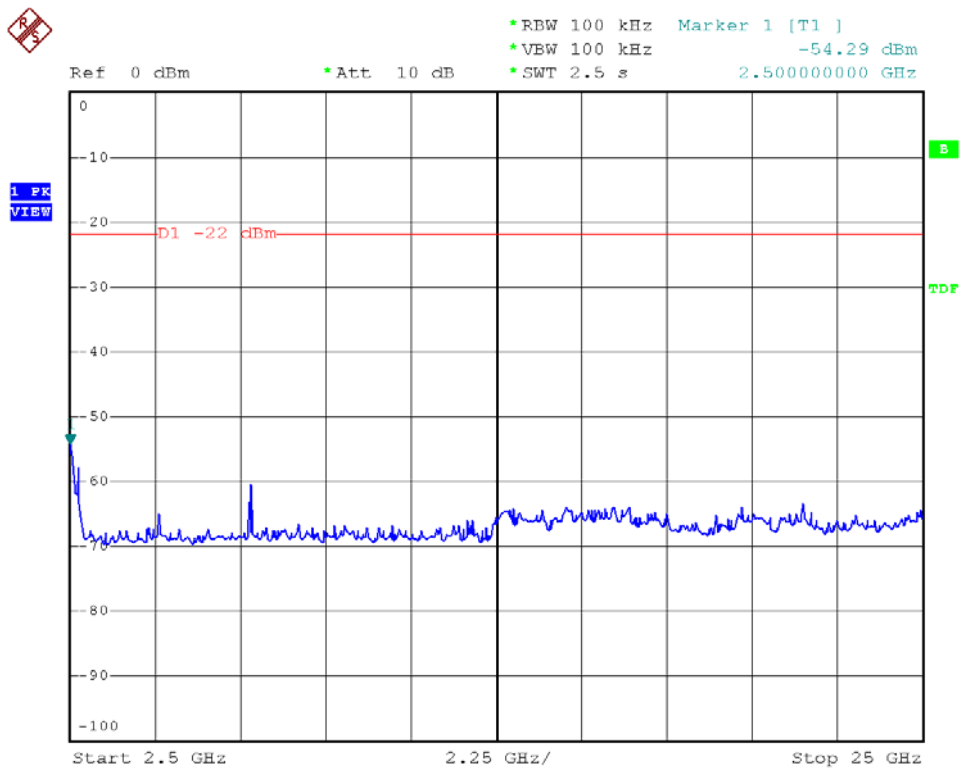
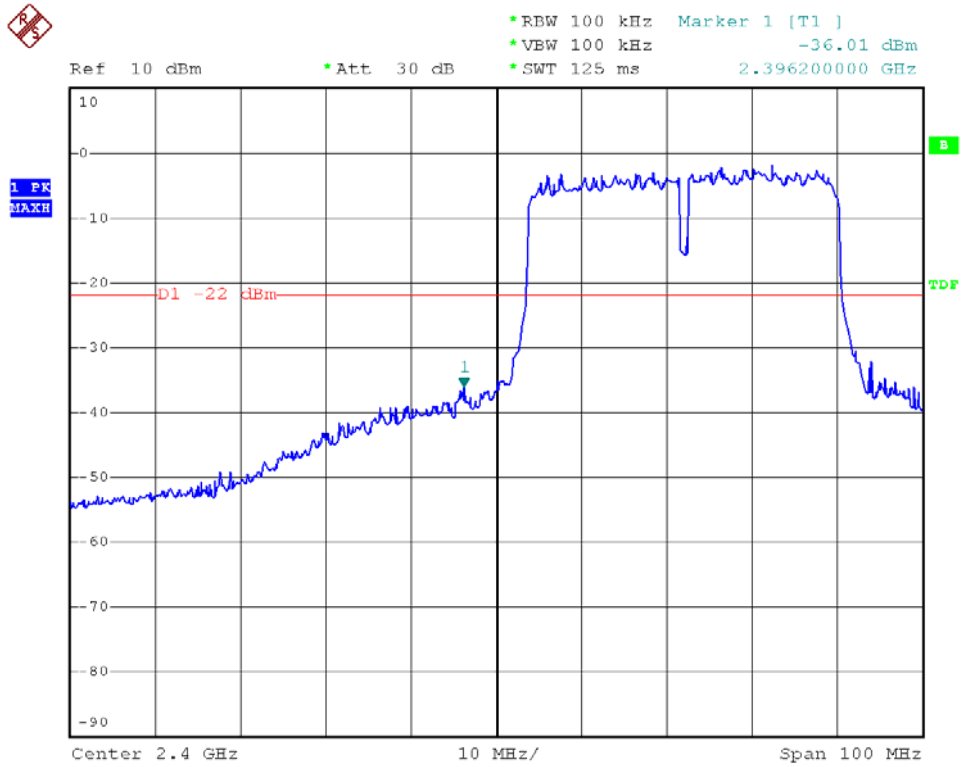



Modulation Standard: 802.11n, HT40 (130Mbps)
Channel: 09

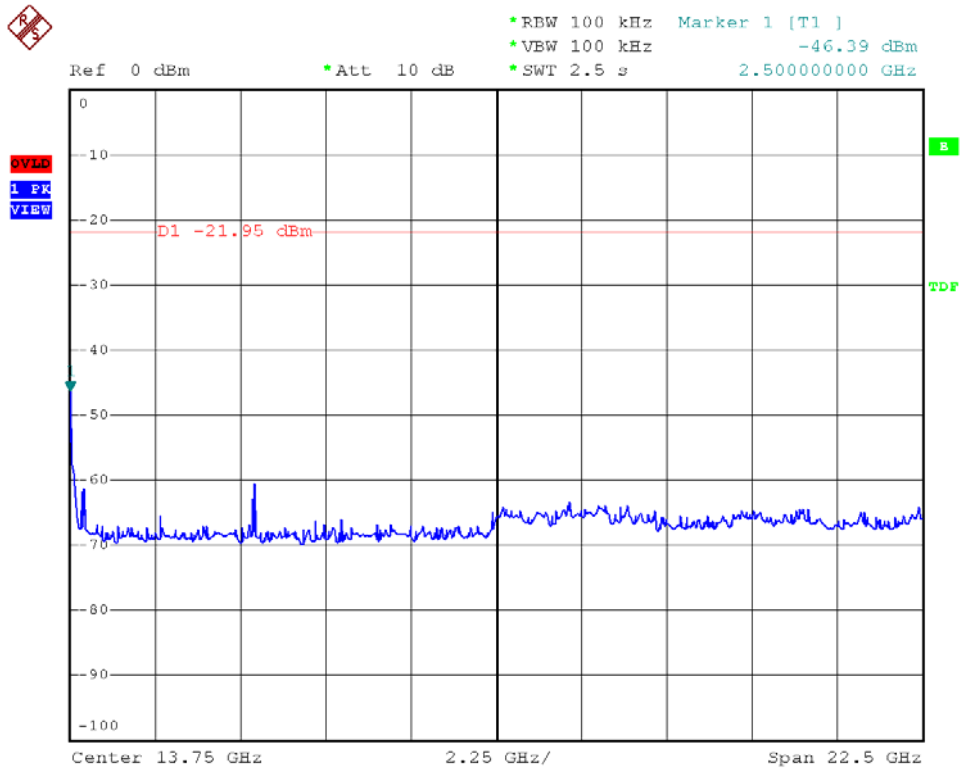
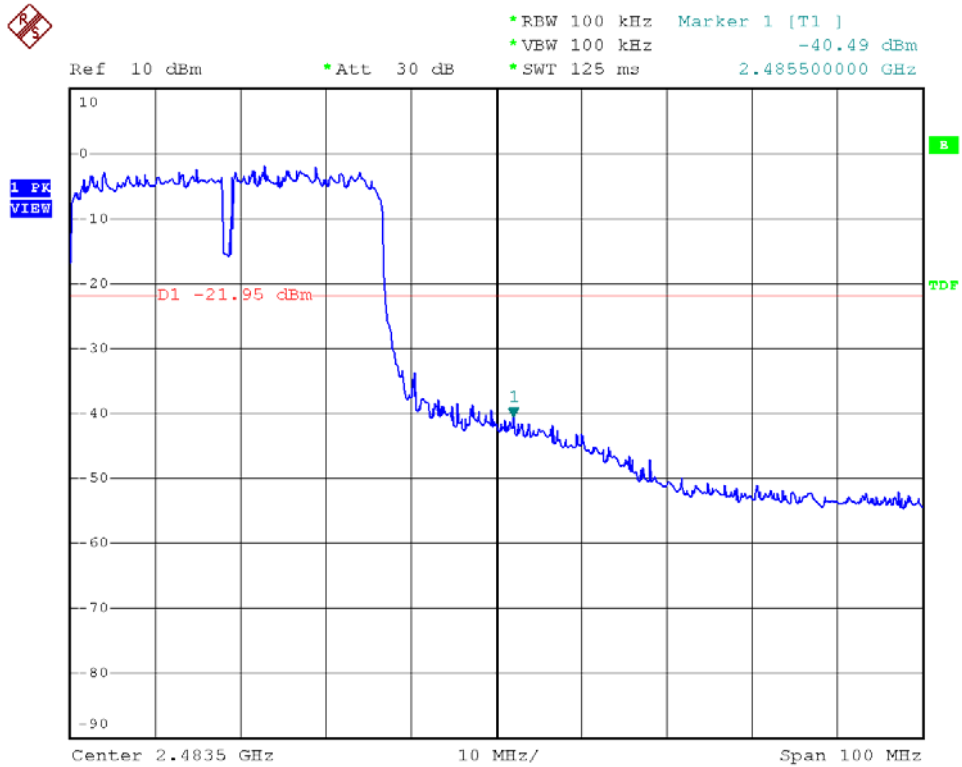



Modulation Standard: 802.11a (54Mbps)
Channel: 149

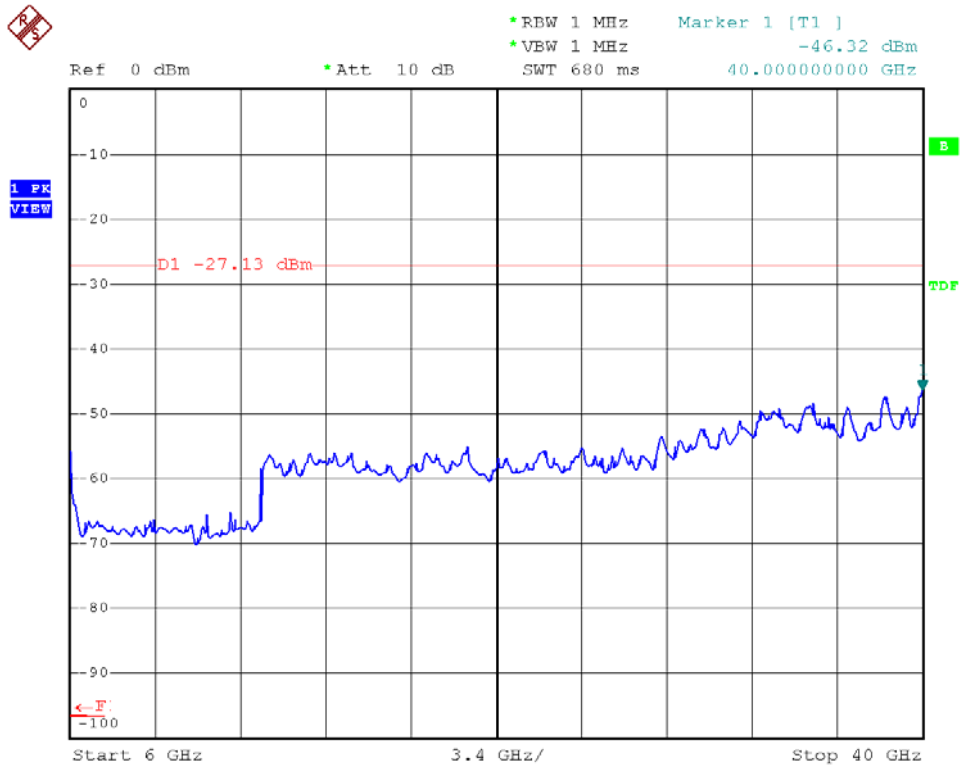
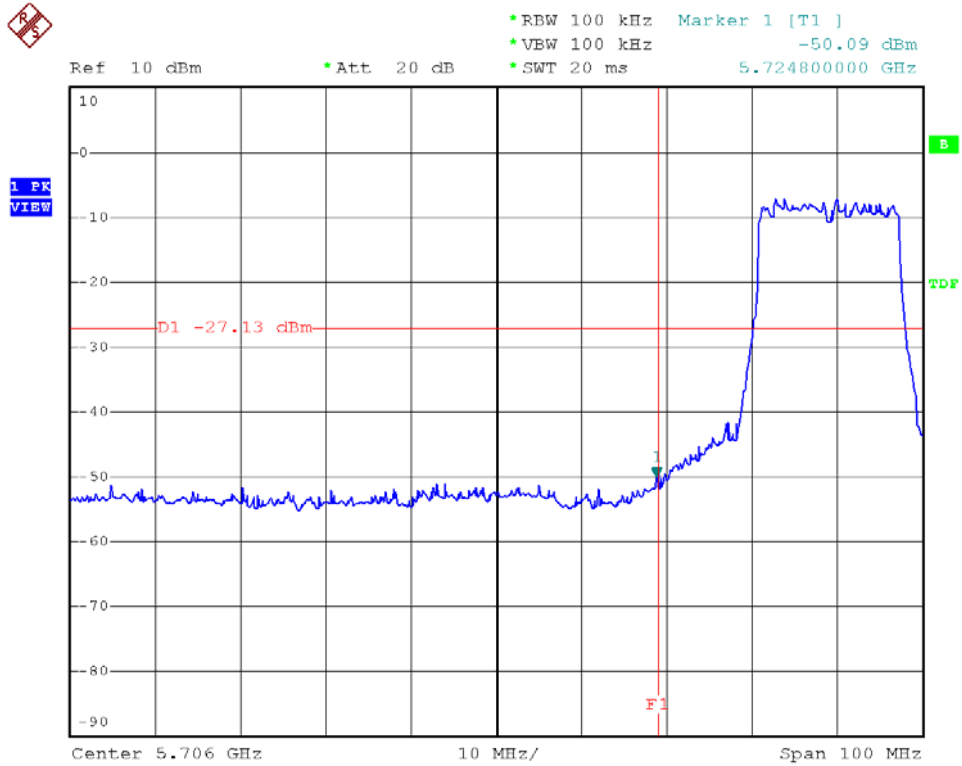



Modulation Standard: 802.11a (54Mbps)
Channel: 165

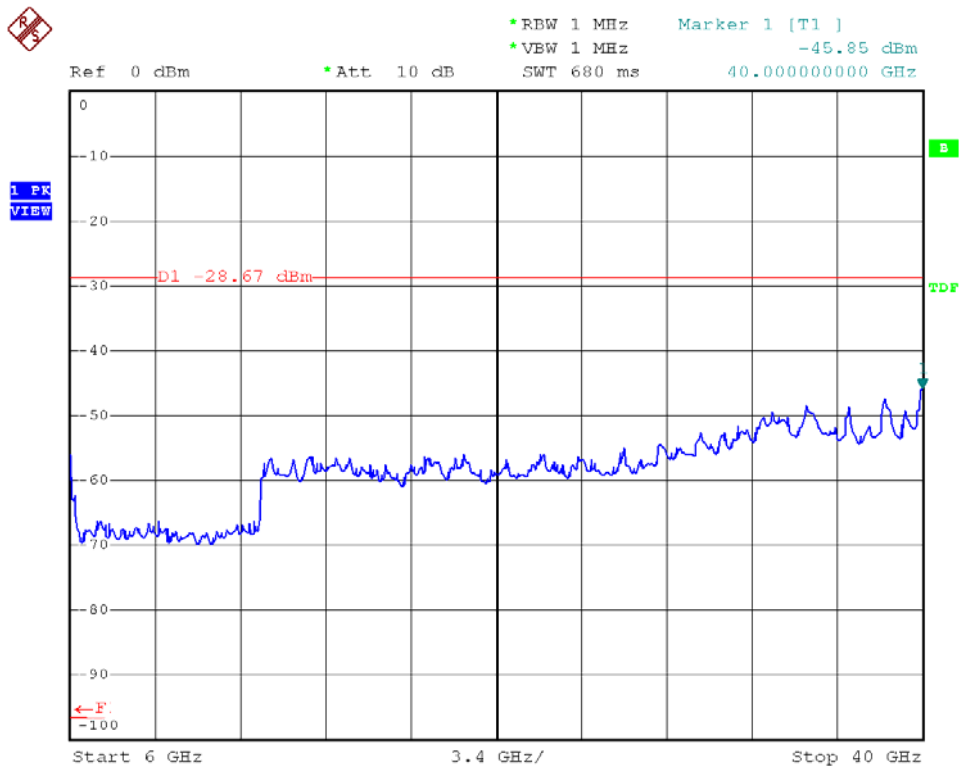
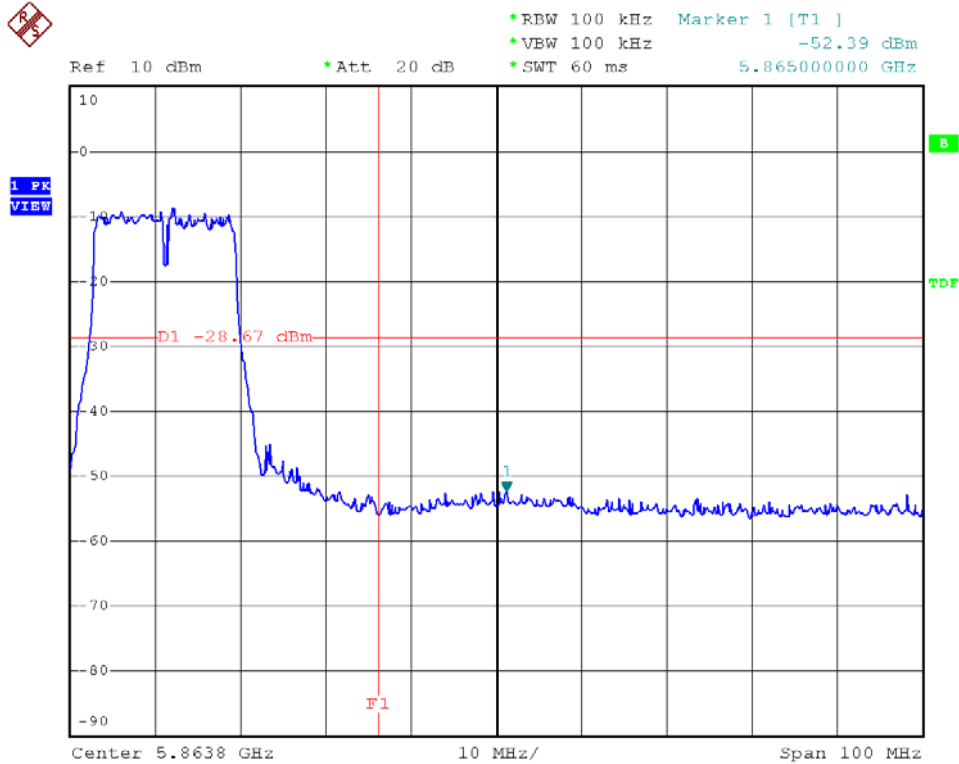



Modulation Standard: 802.11an, HT20 (65Mbps)
Channel: 149

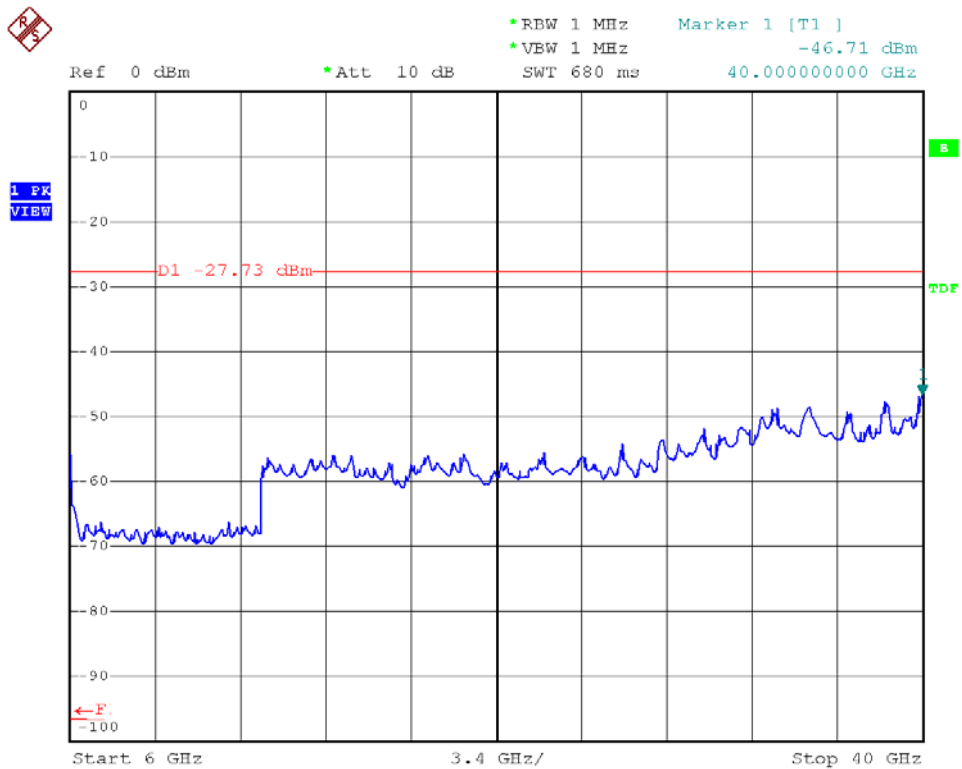
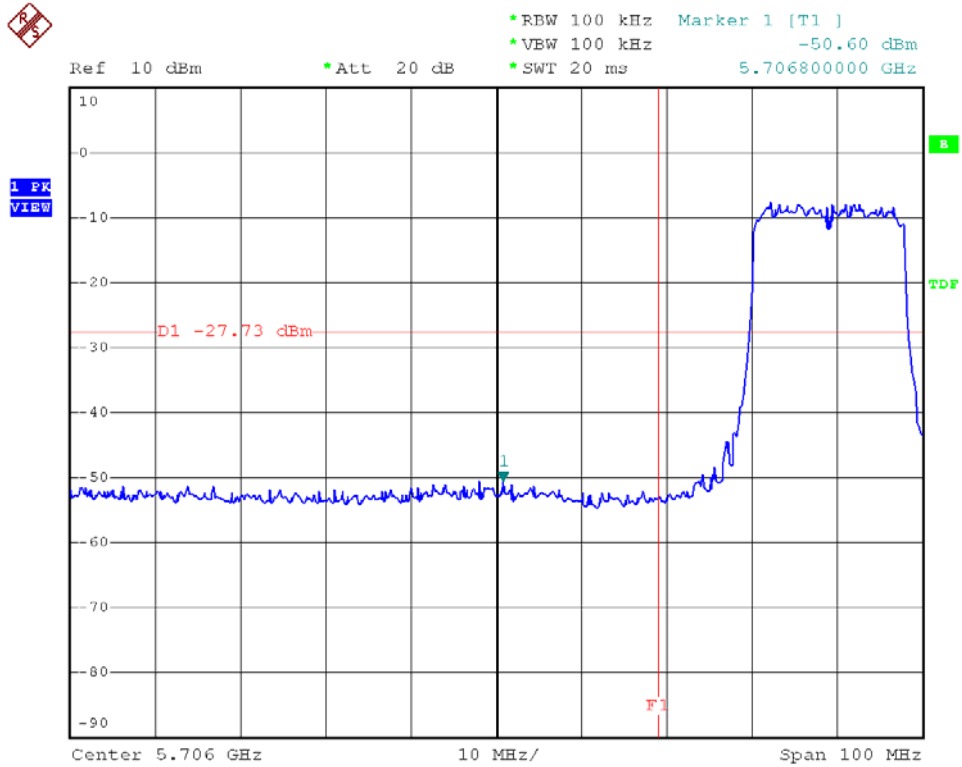



Modulation Standard: 802.11an, HT20 (65Mbps)
Channel: 165

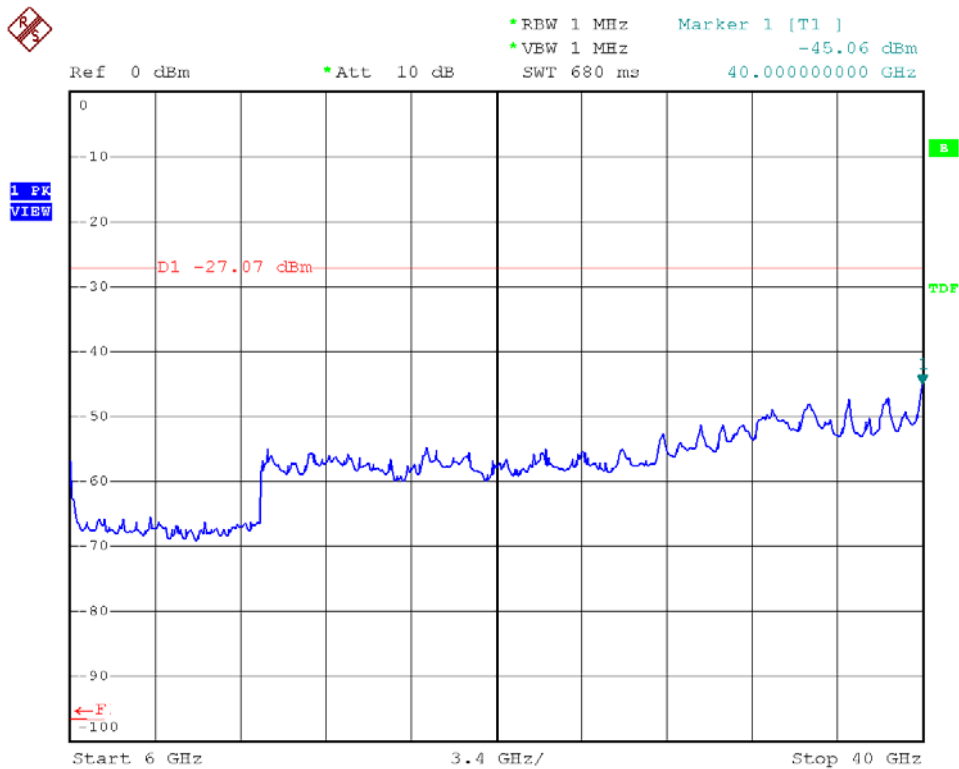
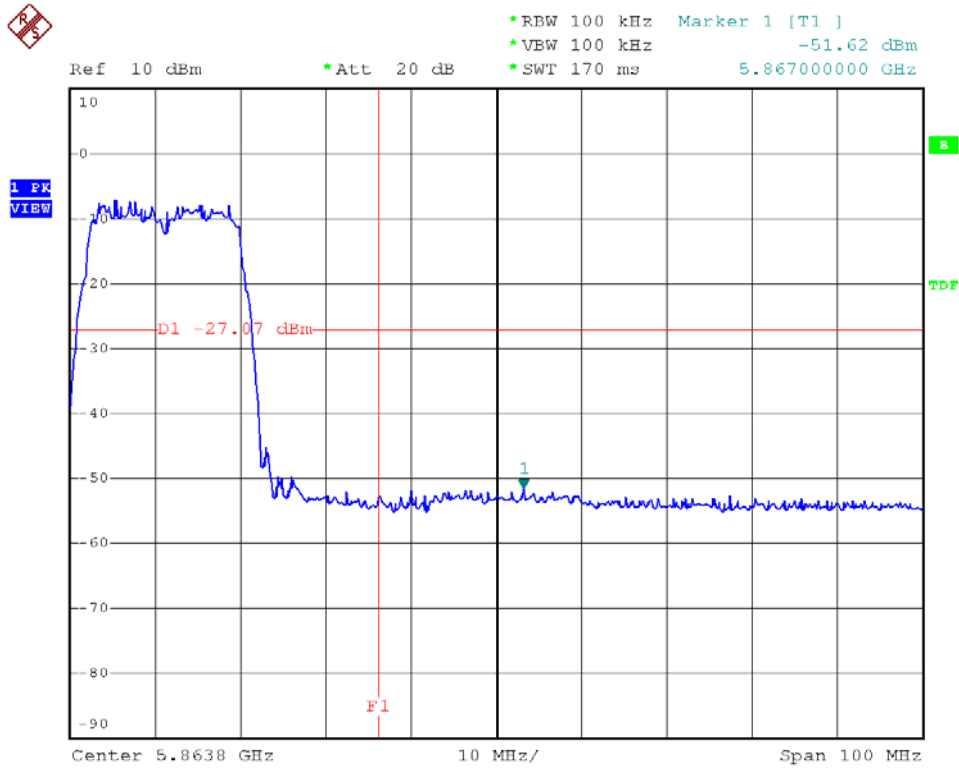



Modulation Standard: 802.11an HT40 (130Mbps)
Channel: 151

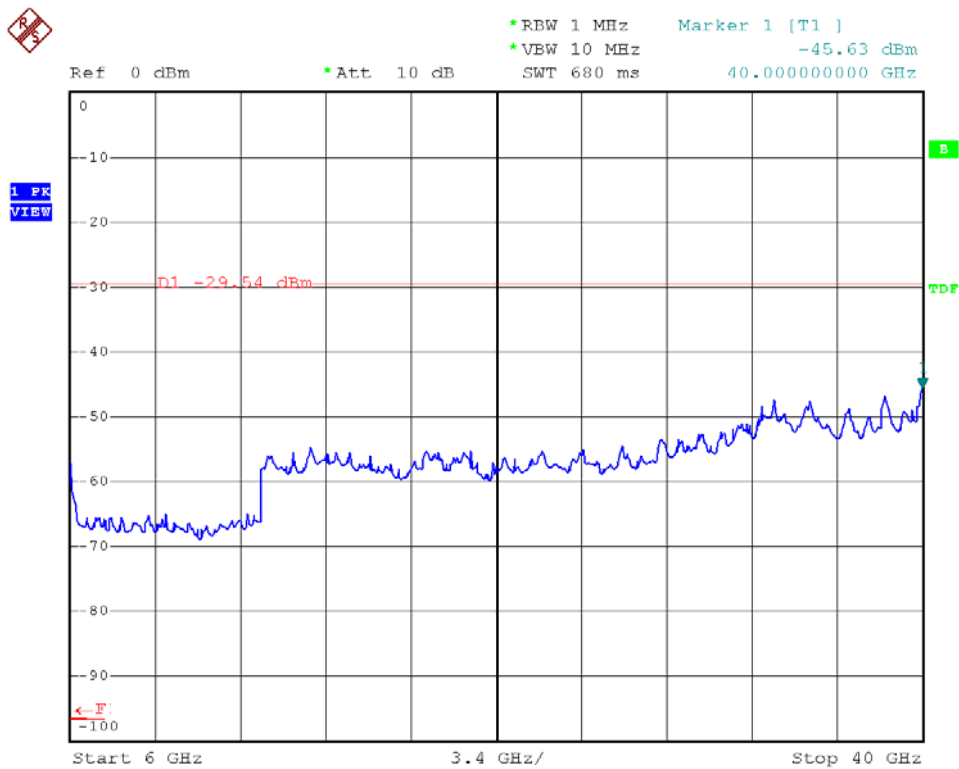
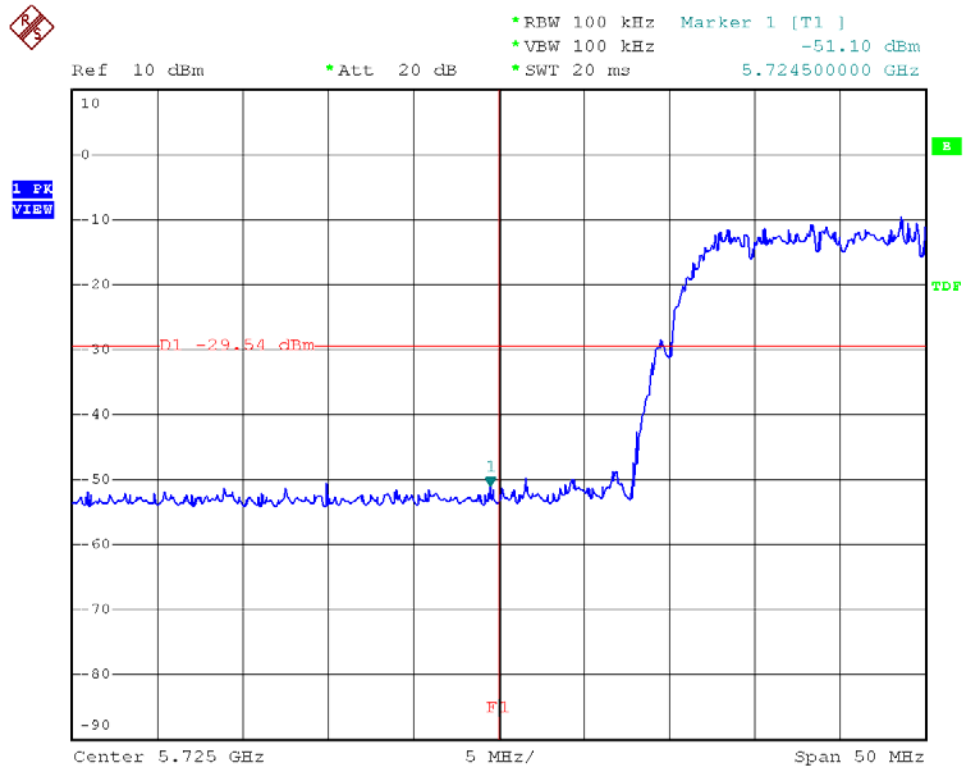



Modulation Standard: 802.11an HT40 (130Mbps)
Channel: 159

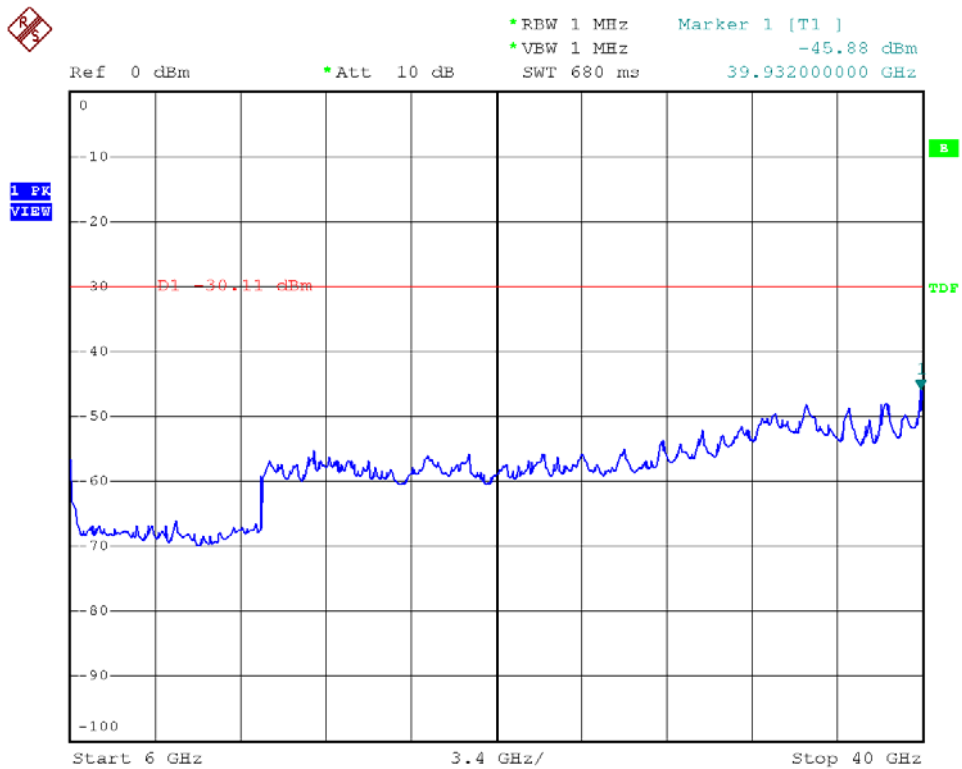
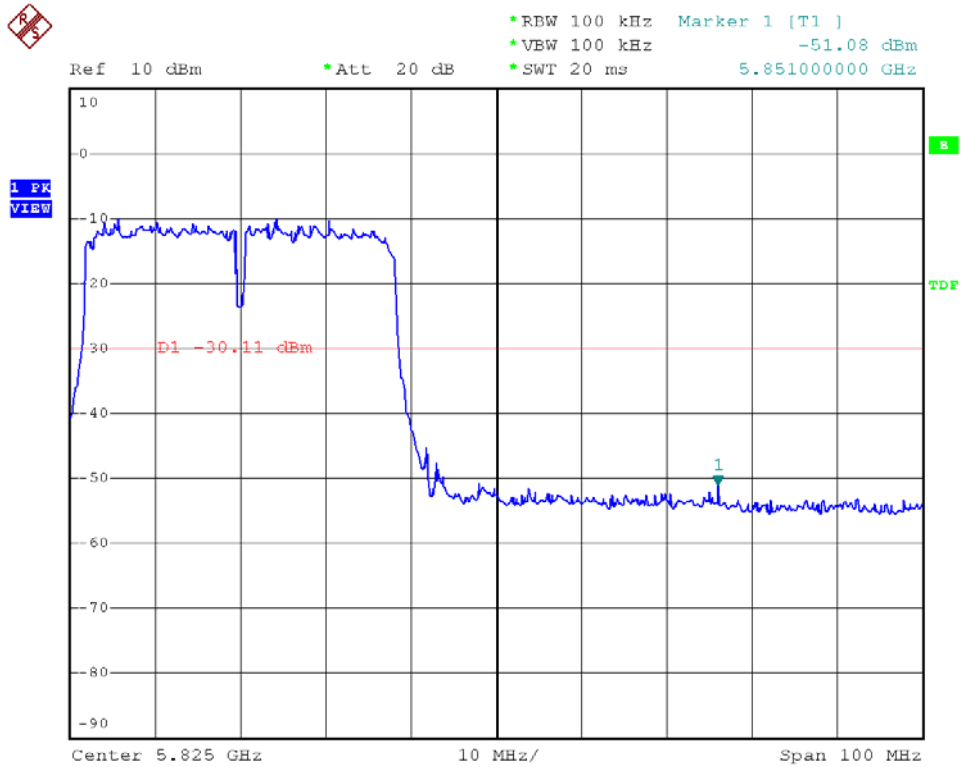



9.6 Restrict Band Emission Measurement Data

Test Date: Jun. 17, 2009

Temperature: 26

Atmospheric pressure: 1022 hPa

Humidity: 67%

Modulation Standard: IEEE 802.11b (11Mbps)

Channel 1						Fundamental Frequency: 2412 MHz				
Frequency (MHz)	Ant-Pol H/V	Meter Reading (dBuV)	Corrected Factor (dB)	Result (dBuV/m)	Remark	Limit (dBuV/m)		Margin (dB)	Table Deg.	Ant High (m)
						Peak	Ave			
2396.09	H	60.18	-0.64	59.54	Peak	74	54	-14.46	180	1.01
2387.21	H	37.55	-0.67	36.88	Ave	74	54	-17.12	180	1.01
2389.87	V	56.37	-0.67	55.70	Peak	74	54	-18.30	180	1.01
2389.97	V	44.12	-0.67	43.45	Ave	74	54	-10.55	180	1.01
Channel 11						Fundamental Frequency: 2462 MHz				
Frequency (MHz)	Ant-Pol H/V	Meter Reading (dBuV)	Corrected Factor (dB)	Result (dBuV/m)	Remark	Limit (dBuV/m)		Margin (dB)	Table Deg.	Ant High (m)
						Peak	Ave			
2486.78	H	53.21	-0.25	52.96	Peak	74	54	-21.04	180	1.01
2487.27	H	42.04	-0.25	41.79	Ave	74	54	-12.21	180	1.01
2484.88	V	58.23	-0.26	57.97	Peak	74	54	-16.03	180	1.01
2487.27	V	46.50	-0.25	46.25	Ave	74	54	-7.75	180	1.01

Modulation Standard: IEEE 802.11g (54Mbps)

Channel 1						Fundamental Frequency: 2412 MHz				
Frequency (MHz)	Ant-Pol H/V	Meter Reading (dBuV)	Corrected Factor (dB)	Result (dBuV/m)	Remark	Limit (dBuV/m)		Margin (dB)	Table Deg.	Ant High (m)
						Peak	Ave			
2389.87	H	50.37	-0.67	49.70	Peak	74	54	-24.30	181	1.01
2389.87	H	35.58	-0.67	34.91	Ave	74	54	-19.09	181	1.01
2389.97	V	57.13	-0.67	56.46	Peak	74	54	-17.54	180	1.01
2389.97	V	41.44	-0.67	40.77	Ave	74	54	-13.23	180	1.01
Channel 11						Fundamental Frequency: 2462 MHz				
Frequency (MHz)	Ant-Pol H/V	Meter Reading (dBuV)	Corrected Factor (dB)	Result (dBuV/m)	Remark	Limit (dBuV/m)		Margin (dB)	Table Deg.	Ant High (m)
						Peak	Ave			
2483.51	H	55.38	-0.27	55.11	Peak	74	54	-18.89	173	1.01
2483.51	H	39.02	-0.27	38.75	Ave	74	54	-15.25	173	1.01
2483.66	V	61.85	-0.27	61.58	Peak	74	54	-12.42	185	1.01
2483.51	V	43.02	-0.27	42.75	Ave	74	54	-11.25	185	1.01



Modulation Standard: IEEE 802.11n HT20 (65Mbps)

Channel 1						Fundamental Frequency: 2412 MHz				
Frequency (MHz)	Ant-Pol H/V	Meter Reading (dBuV)	Corrected Factor (dB)	Result (dBuV/m)	Remark	Limit (dBuV/m)		Margin (dB)	Table Deg.	Ant High (m)
						Peak	Ave			
2389.66	H	52.39	-0.67	51.72	Peak	74	54	-22.28	182	1.01
2389.97	H	35.88	-0.67	35.21	Ave	74	54	-18.79	182	1.01
2389.97	V	60.93	-0.67	60.26	Peak	74	54	-13.74	178	1.01
2389.97	V	41.92	-0.67	41.25	Ave	74	54	-12.75	178	1.01
Channel 11						Fundamental Frequency: 2462 MHz				
Frequency (MHz)	Ant-Pol H/V	Meter Reading (dBuV)	Corrected Factor (dB)	Result (dBuV/m)	Remark	Limit (dBuV/m)		Margin (dB)	Table Deg.	Ant High (m)
						Peak	Ave			
2483.70	H	56.70	-0.27	56.43	Peak	74	54	-17.57	176	1.01
2483.51	H	40.02	-0.27	39.75	Ave	74	54	-14.25	176	1.01
2483.58	V	62.81	-0.27	62.54	Peak	74	54	-11.46	181	1.01
2483.55	V	45.20	-0.27	44.93	Ave	74	54	-9.07	181	1.01

Modulation Standard: IEEE 802.11n HT40 (130Mbps)

Channel 3						Fundamental Frequency: 2422 MHz				
Frequency (MHz)	Ant-Pol H/V	Meter Reading (dBuV)	Corrected Factor (dB)	Result (dBuV/m)	Remark	Limit (dBuV/m)		Margin (dB)	Table Deg.	Ant High (m)
						Peak	Ave			
2389.56	H	52.28	-0.67	51.61	Peak	74	54	-22.39	180	1.01
2389.97	H	38.02	-0.67	37.35	Ave	74	54	-16.65	180	1.01
2389.46	V	59.80	-0.67	59.13	Peak	74	54	-14.87	176	1.01
2389.97	V	44.46	-0.67	43.79	Ave	74	54	-10.21	176	1.01
Channel 9						Fundamental Frequency: 2452 MHz				
Frequency (MHz)	Ant-Pol H/V	Meter Reading (dBuV)	Corrected Factor (dB)	Result (dBuV/m)	Remark	Limit (dBuV/m)		Margin (dB)	Table Deg.	Ant High (m)
						Peak	Ave			
2486.74	H	56.65	-0.25	56.40	Peak	74	54	-17.60	177	1.01
2483.51	H	42.65	-0.27	42.38	Ave	74	54	-11.62	177	1.01
2483.93	V	63.34	-0.27	63.07	Peak	74	54	-10.93	179	1.01
2483.55	V	48.40	-0.27	48.13	Ave	74	54	-5.87	179	1.01

Notes:

1. Result = Meter Reading + Factor
2. Factor = Antenna Factor + Cable Loss – Amplifier
3. The resolution bandwidth of test receiver/spectrum analyzer is 1MHz and video bandwidth is 3 MHz for Peak detection at frequency above 1GHz.
4. The resolution bandwidth of test receiver/spectrum analyzer is 1MHz and video bandwidth is 10 MHz for Average detection at frequency above 1GHz.



10. Restricted Bands of Operation

Only spurious emissions are permitted in any of the frequency bands listed below:

MHz	MHz	MHz	GHz
0.09000 – 0.11000	16.42000 – 16.42300	399.9 – 410.0	4.500 – 5.250
0.49500 – 0.505**	16.69475 – 16.69525	608.0 – 614.0	5.350 – 5.460
2.17350 – 2.19050	16.80425 – 16.80475	960.0 – 1240.0	7.250 – 7.750
4.12500 – 4.12800	25.50000 – 25.67000	1300.0 – 1427.0	8.025 – 8.500
4.17725 – 4.17775	37.50000 – 38.25000	1435.0 – 1626.5	9.000 – 9.200
4.20725 – 4.20775	73.00000 – 74.60000	1645.5 – 1646.5	9.300 – 9.500
6.21500 – 6.21800	74.80000 – 75.20000	1660.0 – 1710.0	10.600 – 12.700
6.26775 – 6.26825	108.00000 – 121.94000	1718.8 – 1722.2	13.250 – 13.400
6.31175 – 6.31225	123.00000 – 138.00000	2200.0 – 2300.0	14.470 – 14.500
8.29100 – 8.29400	149.90000 – 150.05000	2310.0 – 2390.0	15.350 – 16.200
8.36200 – 8.36600	156.52475 – 156.52525	2483.5 – 2500.0	17.700 – 21.400
8.37625 – 8.38675	156.70000 – 156.90000	2655.0 – 2900.0	22.010 – 23.120
8.41425 – 8.41475	162.01250 – 167.17000	3260.0 – 3267.0	23.600 – 24.000
12.29000 – 12.29300	167.72000 – 173.20000	3332.0 – 3339.0	31.200 – 31.800
12.51975 – 12.52025	240.00000 – 285.00000	3345.8 – 3358.0	36.430 – 36.500
12.57675 – 12.57725	322.00000 – 335.40000	3600.0 – 4400.0	Above 38.6
13.36000 – 13.41000			

** : Until February 1, 1999, this restricted band shall be 0.490-0.510 MHz

10.1 Labeling Requirement

The device shall bear the following statement in a conspicuous location on the device:
 This device complies with part 15 of the FCC Rules. Operation is subject to the following two conditions: (1) This device may not cause harmful interference, and (2) this device must accept any interference received, including interference that may cause undesired operation.