



Administrator's Handbook

ARRIS® Embedded Software Version 9.1.2

ARRIS® NVG595 Fiber Business Gateway



Copyright

©ARRIS Enterprises, Inc. 2013 All rights reserved. No part of this publication may be reproduced in any form or by any means or used to make any derivative work (such as translation, transformation, or adaptation) without written permission from ARRIS Enterprises, Inc. ("ARRIS"). ARRIS reserves the right to revise this publication and to make changes in content from time to time without obligation on the part of ARRIS to provide notification of such revision or change.

ARRIS and the ARRIS logo are all trademarks of ARRIS Enterprises, Inc. Other trademarks and trade names may be used in this document to refer to either the entities claiming the marks and the names of their products. ARRIS disclaims proprietary interest in the marks and names of others.

ARRIS provides this guide without warranty of any kind, implied or expressed, including, but not limited to, the implied warranties of merchantability and fitness for a particular purpose. ARRIS may make improvements or changes in the product(s) described in this manual at any time.

The capabilities, system requirements, and/or compatibility with third-party products described herein are subject to change without notice.

EXCEPT AS INDICATED IN THE APPLICABLE SYSTEM PURCHASE AGREEMENT, THE SYSTEM, DOCUMENTATION AND SERVICES ARE PROVIDED "AS IS", AS AVAILABLE, WITHOUT WARRANTY OF ANY KIND. ARRIS GROUP, INC. ("ARRIS") DOES NOT WARRANT THAT THE SYSTEM WILL MEET CUSTOMER'S REQUIREMENTS, OR THAT THEIR OPERATION WILL BE UNINTERRUPTED OR ERROR-FREE, OR THAT ANY ERRORS CAN OR WILL BE FIXED. ARRIS HEREBY DISCLAIMS ALL OTHER WARRANTIES, EXPRESS OR IMPLIED, ORAL OR WRITTEN, WITH RESPECT TO THE SYSTEM AND SERVICES INCLUDING, WITHOUT LIMITATION, ALL IMPLIED WARRANTIES OF TITLE, NON-INFRINGEMENT, INTEGRATION, MERCHANTABILITY OR FITNESS FOR ANY PARTICULAR PURPOSE AND ALL WARRANTIES ARISING FROM ANY COURSE OF DEALING OR PERFORMANCE OR USAGE OF TRADE.

EXCEPT AS INDICATED IN THE APPLICABLE SYSTEM PURCHASE AGREEMENT, ARRIS SHALL NOT BE LIABLE CONCERNING THE SYSTEM OR SUBJECT MATTER OF THIS DOCUMENTATION, REGARDLESS OF THE FORM OF ANY CLAIM OR ACTION (WHETHER IN CONTRACT, NEGLIGENCE, STRICT LIABILITY OR OTHERWISE), FOR ANY (A) MATTER BEYOND ITS REASONABLE CONTROL, (B) LOSS OR INACCURACY OF DATA, LOSS OR INTERRUPTION OF USE, OR COST OF PROCURING SUBSTITUTE TECHNOLOGY, GOODS OR SERVICES, (C) INDIRECT, PUNITIVE, INCIDENTAL, RELIANCE, SPECIAL, EXEMPLARY OR CONSEQUENTIAL DAMAGES INCLUDING, BUT NOT LIMITED TO, LOSS OF BUSINESS, REVENUES, PROFITS OR GOODWILL, OR (D) DIRECT DAMAGES, IN THE AGGREGATE, IN EXCESS OF THE FEES PAID TO IT HEREUNDER FOR THE SYSTEM OR SERVICE GIVING RISE TO SUCH DAMAGES DURING THE 12-MONTH PERIOD PRIOR TO THE DATE THE CAUSE OF ACTION AROSE, EVEN IF COMPANY HAS BEEN ADVISED OF THE POSSIBILITY OF SUCH DAMAGES. THESE LIMITATIONS ARE INDEPENDENT FROM ALL OTHER PROVISIONS OF THIS AGREEMENT AND SHALL APPLY NOTWITHSTANDING THE FAILURE OF ANY REMEDY PROVIDED HEREIN.

All ARRIS products are furnished under a license agreement included with the product. If you are unable to locate a copy of the license agreement, please contact ARRIS

Part number: 592050-002-00

Revision: 9.1.2

Table of Contents

CHAPTER 1 - Introduction	7
About ARRIS® Documentation	7
Documentation Conventions	8
General	8
Internal Web Interface	8
Command Line Interface	8
Organization	9
A Word About Example Screens	9
CHAPTER 2 - Device Configuration	11
Important Safety Instructions	12
POWER SUPPLY INSTALLATION	12
TELECOMMUNICATION INSTALLATION	12
PRODUCT VENTILATION	12
ARRIS® Gateway Status Indicator Lights	13
Set up the ARRIS Gateway	16
Microsoft Windows:	16
Macintosh MacOS 8 or higher or Mac OS X:	18
Attaching a Fiber Optic Module	19
Accessing the Web Management Interface	20
IP Diagnostics Page Redirect	21
Offline Troubleshooting	21
Device Status page	22
Device Access Code	22
Tab Bar	24
Help	24
Links Bar	24
Device List	25
System Information	27
Access Code	28
Remote Access	29
Restart Device	31
Broadband	32
Configure	34
Fiber Status	35
Local Network	37
Configure	40
Wi-Fi	41
Wi-Fi Security	44
MAC Filtering	46
Wi-Fi Scan	47
Subnets & DHCP	48

IP Allocation	50
Voice	52
Line Details	53
Call Statistics	54
Firewall	58
Packet Filter	60
Working with Packet Filters	62
NAT/Gaming	69
Custom Services	71
Public Subnet Hosts	74
IP Passthrough	75
Firewall Advanced	78
Diagnostics	80
Logs	83
Update	85
Resets	86
Syslog	87
Event Notifications	88
NAT Table	89

CHAPTER 3 - Basic Troubleshooting **91**

Status Indicator Lights	92
LED Function Summary Matrix	95
Factory Reset Switch	98
Log Event Messages	99

CHAPTER 4 - Command Line Interface **103**

Overview	105
Starting and Ending a CLI Session	107
Logging In	107
Ending a CLI Session	107
Using the CLI Help Facility	108
About SHELL Commands	108
SHELL Prompt	108
SHELL Command Shortcuts	108
SHELL Commands	109
Common Commands	109
WAN Commands	118
About CONFIG Commands	119
CONFIG Mode Prompt	119
Navigating the CONFIG Hierarchy	119
Entering Commands in CONFIG Mode	119
Guidelines: CONFIG Commands	120
Displaying Current Gateway Settings	120
Step Mode: A CLI Configuration Technique	120

Validating Your Configuration	121
CONFIG Commands	122
Connection commands	122
Filterset commands	126
Global Filterset ("IPv6 Firewall") commands	129
Queue commands	130
IP Gateway commands	133
IPv6 Commands	133
IP DNS commands	140
IP IGMP commands	140
NTP commands	143
Application Layer Gateway (ALG) commands	143
Dynamic DNS Commands	144
Link commands	144
Management commands	147
Remote access commands	149
Physical interfaces commands	151
PPPoE relay commands	154
NAT Pinhole commands	154
Security Stateful Packet Inspection (SPI) commands	155
VoIP commands	157
Targeted Ad Insertion commands	167
System commands	169
Debug Commands	174
Disclaimer & Warning Text	174
Commands	174
CLI CShell Commands (debug mode)	174

CHAPTER 5 - Technical Specifications and Safety Information. 175

Description	175
Power Supply	175
Environment	175
Software and protocols	175
Agency approvals	176
Manufacturer's Declaration of Conformance	177
Important Safety Instructions	179
47 CFR Part 68 Information	180
FCC Requirements	180
FCC Statements	180
RF Exposure Statement:	181
Electrical Safety Advisory	181
Caring for the Environment by Recycling	182
Beskyttelse af miljøet med genbrug	182
Umweltschutz durch Recycling	182
Cuidar el medio ambiente mediante el reciclaje	182
Recyclage pour le respect de l'environnement	182
Milieubewust recycleren	183
Dba ³ oËç o Ërodowisko - recykling	183

Cuidando do meio ambiente através da reciclagem	183
Var rädd om miljön genom återvinning.	183
Copyright Acknowledgments	185
Open Source Software Information	185

Appendix A - ARRIS® Gateway Captive Portal Implementation 209

Overview	210
Captive Portal RPC	211
X_00D09E_GetCaptivePortalParams RPC:	211
X_00D09E_SetCaptivePortalParams RPC:	212

Appendix B - Quality of Service (QoS) Examples 213

Overview	214
Downstream QoS: Ethernet Switch	216
Downstream QoS: Egress queues	217

Index **219**

CHAPTER 1 Introduction

About ARRIS® Documentation



NOTE::

This guide describes the wide variety of features and functionality of the ARRIS® Gateway, when used in Router mode. The ARRIS® Gateway may also be delivered in Bridge mode. In Bridge mode, the Gateway acts as a pass-through device and allows the workstations on your LAN to have public addresses directly on the Internet.

ARRIS provides a suite of technical information for its family of intelligent enterprise and consumer Gateways. It consists of:

- ◆ Administrator's Handbook
- ◆ Dedicated User Manuals
- ◆ Specific White Papers

The documents are available in electronic form as Portable Document Format (PDF) files. They are viewed (and printed) from Adobe Acrobat Reader, Exchange, or any other application that supports PDF files.

They are downloadable from the ARRIS website:

<http://www.arrisi.com/consumer>



Documentation Conventions

General

This manual uses the following conventions to present information:

Convention (Typeface)	Description
bold sans serif	Menu commands and button names
<u>underlined sans serif</u>	Web GUI page links
terminal	Computer display text
bold terminal	User-entered text
<i>italic</i>	Italic type indicates the complete titles of manuals.

Internal Web Interface

Convention (Graphics)	Description
	Denotes an "excerpt" from a Web page or the visual truncation of a Web page
	Denotes an area of emphasis on a Web page



Command Line Interface

Syntax conventions for the ARRIS® Gateway command line interface are as follows:

Convention	Description
straight ([]) brackets in cmd line	Optional command arguments
curly ({ }) brackets, with values separated with vertical bars ().	Alternative values for an argument are presented in curly ({ }) brackets, with values separated with vertical bars ().
bold terminal type face	User-entered text
<i>italic terminal type face</i>	Variables for which you supply your own values

Organization

This guide consists of five chapters, two appendices, and an index. It is organized as follows:

- ◆ **Chapter 1, “Introduction”** — Describes the ARRIS® document suite, the purpose of, the audience for, and structure of this guide. It gives a table of conventions.
- ◆ **Chapter 2, “Device Configuration”** — Describes how to get up and running with your ARRIS® Gateway.
- ◆ **Chapter 3, “Basic Troubleshooting”** — Gives some simple suggestions for troubleshooting problems with your Gateway’s initial configuration.
- ◆ **Chapter 4, “Command Line Interface”** — Describes all the current text-based commands for both the SHELL and CONFIG modes. A summary table and individual command examples for each mode is provided.
- ◆ **Chapter 5, “Technical Specifications and Safety Information”** — Presents system and device specifications and important compliance and safety statements.
- ◆ **Appendix A ARRIS® Gateway Captive Portal Implementation** — Describes the ARRIS® Gateway Captive Portal Implementation
- ◆ **Appendix B Quality of Service (QoS) Examples** — Describes the ARRIS® Gateway Quality of Service (QoS) Implementation

A Word About Example Screens

This manual contains many example screen illustrations. Since ARRIS® Gateways offer a wide variety of features and functionality, the example screens shown may not appear exactly the same for your particular Gateway or setup as they appear in this manual. The example screens are for illustrative and explanatory purposes, and should not be construed to represent your own unique environment.

CHAPTER 2 Device Configuration

Most users will find that the basic Quick Start configuration insert that is shipped with the device is all that they ever need to use. For more advanced users, this section provides a rich set of features that can be used for more in-depth configuration. The following topics cover installation in Router Mode.

This chapter covers:

- ◆ [“Important Safety Instructions” on page 12](#)
- ◆ [“ARRIS® Gateway Status Indicator Lights” on page 13](#)
- ◆ [“Set up the ARRIS Gateway” on page 16](#)
- ◆ [“Accessing the Web Management Interface” on page 20](#)
- ◆ [“Device Status page” on page 22](#)
- ◆ [“Tab Bar” on page 24](#)
- ◆ [“Broadband” on page 32](#)
- ◆ [“Local Network” on page 37](#)
- ◆ [“Wi-Fi” on page 41](#)
- ◆ [“Voice” on page 52](#)
- ◆ [“Firewall” on page 58](#)
- ◆ [“Diagnostics” on page 80](#)

Important Safety Instructions

POWER SUPPLY INSTALLATION

Connect the power supply cord to the power jack on the ARRIS® Gateway. Plug the power supply into an appropriate electrical outlet. There is no power (on / off) switch to power off the device.



CAUTION:

Depending on the power supply provided with the product, either the direct plug-in power supply blades, power supply cord plug or the appliance coupler serves as the mains power disconnect. It is important that the direct plug-in power supply, socket-outlet or appliance coupler be located so it is readily accessible.

TELECOMMUNICATION INSTALLATION

When using your telephone equipment, basic safety precautions should always be followed to reduce the risk of fire, electric shock and injury to persons, including the following:

- ◆ Do not use this product near water, for example, near a bathtub, wash bowl, kitchen sink or laundry tub, in a wet basement or near a swimming pool.
- ◆ Avoid using a telephone (other than a cordless type) during an electrical storm. There may be a remote risk of electrical shock from lightning.
- ◆ Do not use the telephone to report a gas leak in the vicinity of the leak.
- ◆ **CAUTION:** The external phone should be UL Listed and the connections should be made in accordance with Article 800 of the NEC.

PRODUCT VENTILATION

The ARRIS® Gateway is intended for use in a business. Ambient temperatures around this product should not exceed 104 F (40 C). It should not be used in locations exposed to outside heat radiation or trapping of its own heat. When properly installed the product should have at least one inch of clearance on all sides except the bottom and should not be placed inside tightly enclosed spaces unless proper ventilation is provided.

SAVE THESE INSTRUCTIONS

ARRIS® Gateway Status Indicator Lights

Colored LEDs on your ARRIS® Gateway indicate the status of various port activity.

ARRIS® Gateway NVG595 status indicator lights

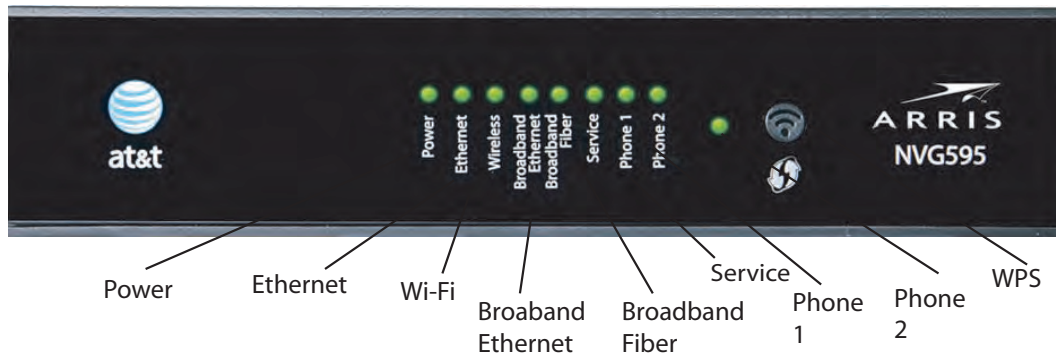

LED	Action
Power*	<p>Solid Green = The device is powered.</p> <p>Flashing Green = A Power-On Self-Test (POST) is in progress</p> <p>Flashing Red = A POST failure (not bootable) or device malfunction occurred.</p> <p>Orange/Amber = during firmware upgrade (see below)</p> <p>Off = The unit has no AC power.</p>
*During Firmware Upgrade	<p>During the software installation, you will lose internet and phone service. The LEDs will function as follows:</p> <ol style="list-style-type: none"> As firmware is being loaded into flash, the LEDs will operate normally as described. The installation will take a few minutes – During this phase, the Power LED will flash Orange/Amber during firmware upgrade (flash writing to memory) and all other LEDs will be off. The Gateway will restart automatically. As the device reboots, the POWER ON LED behavior will happen.
During Boot process	<ul style="list-style-type: none"> Power LED = GREEN/FLASH All other LED = OFF <p>If the device does not boot, and fails its self test or fails to perform initial load of the bootloader:</p> <ul style="list-style-type: none"> Power LED = RED/FLASH ALL other LED = OFF <p>If the device boots and then detects a failure:</p> <p>Power LED = GREEN/FLASH starting POST and then all LEDs will FLASH RED, including Power LED.</p>
Ethernet	<p>Solid Green = Powered device connected to the associated port (includes devices with wake-on-LAN capability where a slight voltage is supplied to the Ethernet connection).</p> <p>Flickering Green = Activity seen from devices associated with the port. The flickering of the light is synchronized to actual data traffic.</p> <p>Off = The device is not powered, no cable or no powered devices connected to the associated ports.</p>
Wi-Fi	<p>Solid Green = Wi-Fi is powered.</p> <p>Flickering Green = Activity seen from devices connected via Wi-Fi. The flickering of the light is synchronized to actual data traffic.</p> <p>Off = The device is not powered or no powered devices connected to the associated ports.</p>

LED	Action
<p>Broadband Ethernet</p>	<p>Solid Green = Good broadband connection.</p> <p>Flashing Green & Red = If the broadband connection fails to be established for more than three consecutive minutes the LED switches to Flashing Green when attempting or waiting to establish a broadband connection alternating with a five second steady Red. This pattern continues until the broadband connection is successfully established.</p> <p>Flashing Red = No signal on the line. This is only used when there is no signal, not during the training sequence.</p> <p>Off = The device is not powered.</p>
<p>Broadband Fiber</p>	<p>Solid Green = Good broadband connection.</p> <p>Flashing Green & Red = If the broadband connection fails to be established for more than three consecutive minutes the LED switches to Flashing Green when attempting or waiting to establish a broadband connection alternating with a five second steady Red. This pattern continues until the broadband connection is successfully established.</p> <p>Flashing Red = No signal on the line. This is only used when there is no signal, not during the training sequence.</p> <p>Off = The device is not powered.</p>
<p>Service</p>	<p>Solid Green = IP connected (The device has a WAN IP address from DHCP or 802.1x authentication and the broadband connection is up)</p> <p>Flashing Green = Attempting connection, attempting IEEE 802.1X authentication or attempting to obtain DHCP information.</p> <p>Red = Device attempted to become IP connected and failed (no DHCP response, 802.1x authentication failed, no IP address from IPCP, etc.). The Red state times out after two minutes and the Service indicator light returns to the Off state.</p> <p>Off = The device is not powered or the broadband connection is not present.</p>
<p>Phone 1, 2</p>	<p>Solid Green = The associated VoIP line has been registered with a SIP proxy server.</p> <p>Flashing Green = Indicates a telephone is off-hook on the associated VoIP line.</p> <p>Off = VoIP not in use, line not registered or Gateway power off.</p>
<p>WPS (opens after using WPS button)</p> 	<p>Solid Green = Wi-Fi Protected Setup has been completed successfully. It should stay on for 5 minutes or until push button is pressed again.</p> <p>Flashing Green = for 2 mins. Indicates when WPS is broadcasting.</p> <p>Flashing Red = for 2 min, when there is a Session overlap detected (possible security risk) in scenario.</p> <p>Solid Red = Error unrelated to security, such as failed to find any partner, or WPS is disabled. It should stay Solid Red for 5 min or until push button is pressed again.</p> <p>Off = The device is not powered, no cable or no powered devices connected to the associated ports.</p>

ARRIS® Gateway NVG595 Rear View

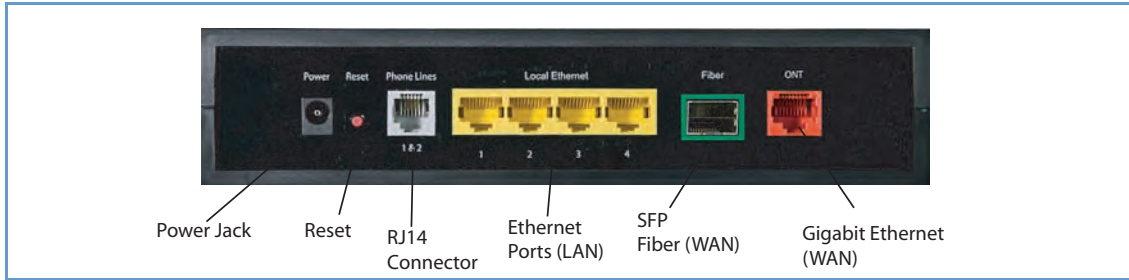

LED	Action
<p>Ethernet 1, 2, 3, 4</p>	<p>Orange/Amber when a Gigabit Ethernet device is connected to each port. Green when 10/100 Ethernet device is connected. Flash for Ethernet traffic passing. Off = The device is not powered, or no powered devices connected to the associated ports.</p>



NOTE:

The NVG595 supports two VoIP lines over one RJ14 VoIP port. In order to connect two phone lines the supplied inner/outer pair splitter adapters must be attached to the RJ14 VoIP port in order to terminate both lines. This is a special-purpose splitter. You must only use the inner/outer pair splitter adapters supplied by AT&T.



Set up the ARRIS Gateway

Refer to your Quickstart Guide for instructions on how to connect your ARRIS[®] gateway to your power source, PC or local area network, and your Internet access point, whether it is a Fiber connection or a Gigabit Ethernet connection. Different ARRIS[®] Gateway models are supplied for any of these connections. If Dynamic Addressing is not enabled on your PC, perform the following.

Microsoft Windows:

1. Navigate to the TCP/IP Properties Control Panel.

Some Windows versions follow a path like this:

Start menu -> **Settings** -> **Control Panel** -> **Network** (or **Network and Dial-up Connections** -> **Local Area Connection** -> **Properties**) -> **TCP/IP [your_network_card]** or **Internet Protocol [TCP/IP]** -> **Properties**

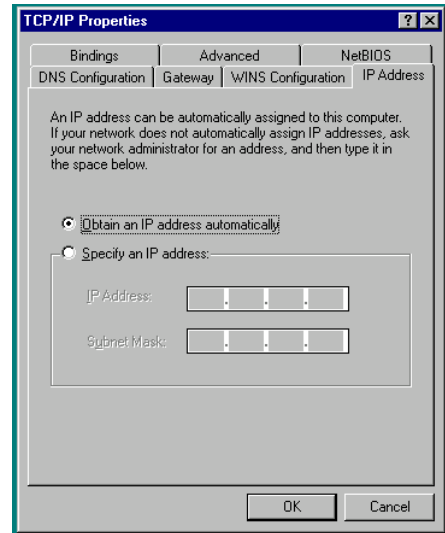

Some Windows versions follow a path like this:

Start menu -> **Control Panel** -> **Network and Internet Connections** -> **Network Connections** -> **Local Area Connection** -> **Properties** -> **Internet Protocol [TCP/IP]** -> **Properties**

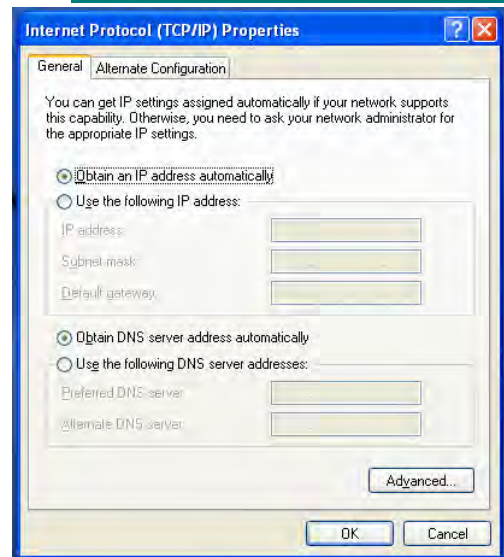

2. Select Obtain an IP address automatically.
3. Select Obtain DNS server address automatically, if available.
4. Remove any previously configured Gateways, if available.
5. OK the settings. Restart if prompted.

Windows Vista and Windows 7 obtain an IP address automatically by default. You may not need to configure it at all.

To check;

1. Open the **Networking** Control Panel and select **Internet Protocol Version 4 (TCP/IPv4)**.
2. Click the **Properties** button. The **Internet Protocol Version 4 (TCP/IPv4) Properties** window should appear as shown.

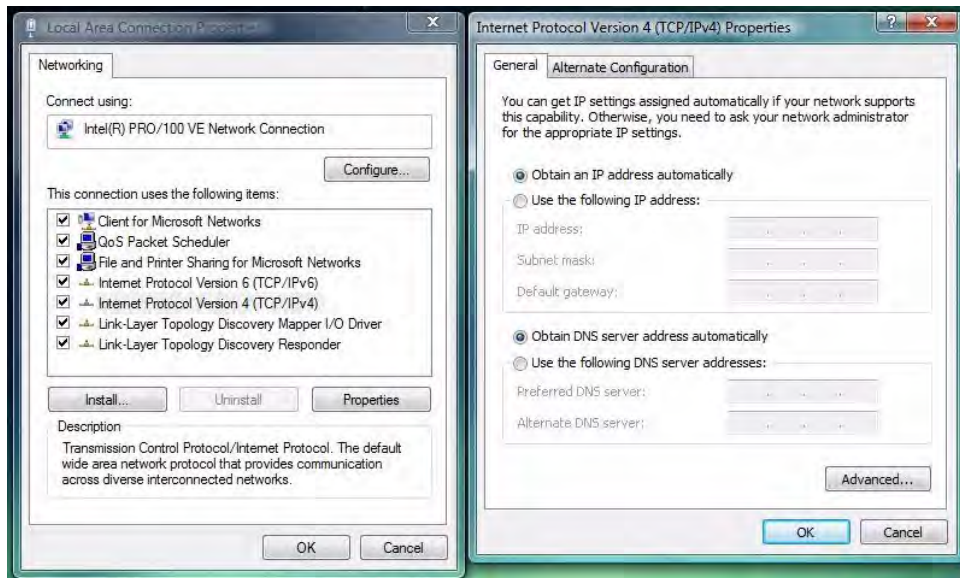

3. Set the radio buttons to the values shown above, and click the **OK** button.

Macintosh MacOS 8 or higher or Mac OS X:

1. Access the TCP/IP or Network control panel.
- ◆ MacOS follows a path like this:

Apple Menu -> **Control Panels** -> **TCP/IP Control Panel**

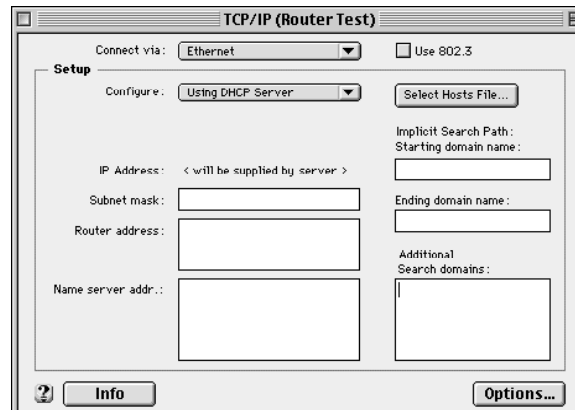

- ◆ Mac OS X follows a path like this:

Apple Menu -> **System Preferences** -> **Network**

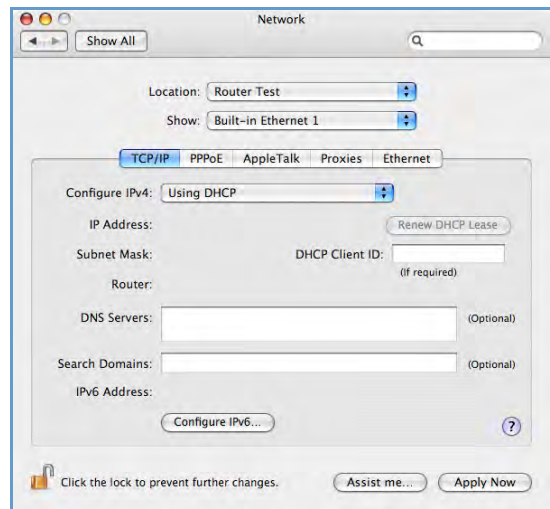

2. Select Built-in Ethernet
3. Select Configure Using DHCP
4. Close and Save, if prompted.

Proceed to [“Accessing the Web Management Interface” on page 20.](#)

Attaching a Fiber Optic Module

The following procedure details how to attach an SFP SX/LX connector to the NVG595 and attach the fiber optic cable to the Optic module.



WARNING!

Laser output can cause serious eye damage. The lasers used in this device produce light that is invisible to the naked eye. Assume at all times that the fiber optic cables and optical ports are radiating light energy. When connecting or handling the fiber cables or connectors, it is imperative that no one looks into the tip of the fiber.

1. Insert the SFP SX/LX fiber optic module into the Fiber port on the rear of the NVG595. Push it in firmly until it clicks. The label on the module should be facing upward when the module is inserted. Failure to ensure this could cause damage to the module.

2. Remove the rubber protective cap from the end of the SFP SX/LX fiber optic module.
3. Remove the protective plastic caps from the end of the fiber cable and insert the fiber cable into the SFP SX/LX fiber optic module. Push firmly until the latch on the end of the connector locks over the fiber cable.

Accessing the Web Management Interface

1. Run your Web browser application, such as Firefox or Microsoft Internet Explorer, from the computer connected to the ARRIS® Gateway.
2. Enter <http://192.168.7.254> in the Location text box. Once the network type is determined, The Device Status Page opens.

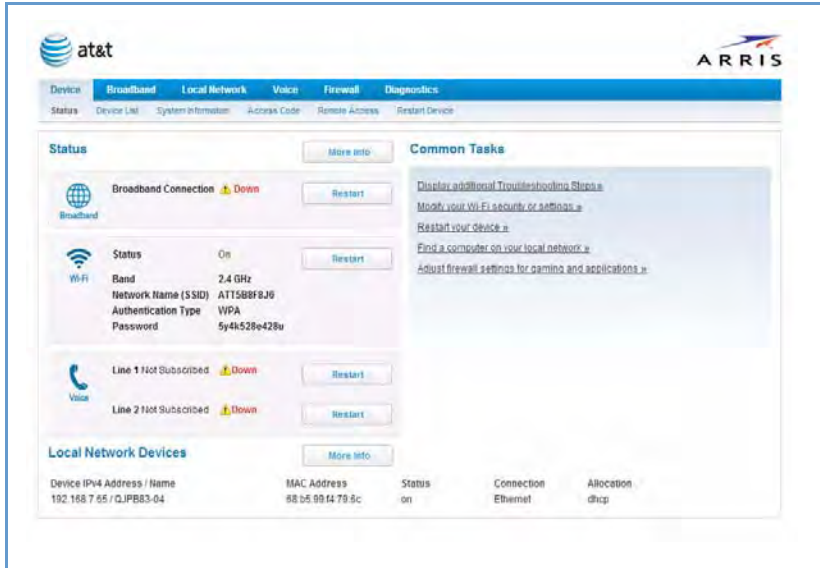

3. Check to make sure the Broadband and Service LEDs are lit **GREEN** to verify that the connection to the Internet is active.

IP Diagnostics Page Redirect

In the event that your connection to the Internet fails, the **Broadband LED** will flash **RED** and you will be redirected to the **IP Diagnostics** page.

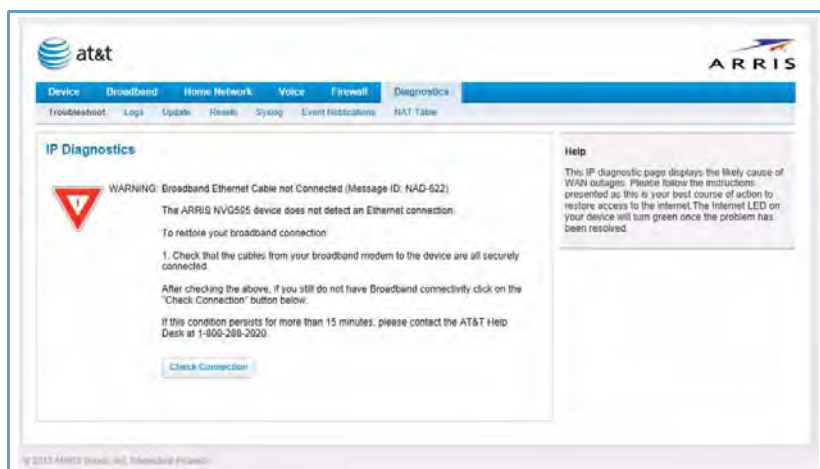

Follow the on-screen troubleshooting suggestions.

For additional troubleshooting information, see [“Diagnostics” on page 80](#) and [“Basic Troubleshooting” on page 91](#).

When your connection is restored or the problem is resolved, the **Broadband LED** will turn **GREEN**.



NOTE:

For AT&T this function is enabled by default. See the CLI command [“set management lan-redirect enable \[off | on \]” on page 150](#)

Offline Troubleshooting

If the WAN is down, the following information is displayed at the top of the page:

Offline Troubleshooting

If you have a problem with your device, perform the following steps, in order:

1. Click the “Restart” button next to each system below marked as “Down”.
2. Restart your device using the button below.
3. If this condition persists for more than 15 minutes, please contact the AT&T Help Desk at 1-800-288-2020.

Device Status page

After you have performed the basic Easy Login configuration, any time you log in to your ARRIS® Gateway you will access the ARRIS® Gateway Home Page.

You access the Home Page by typing `http://192.168.7.254` in your web browser's location box.

Device Access Code

You may be required to provide your Device Access Code in order to access the web management configuration pages. The **Device Access Code** is unique to your device. It is printed on a label on the bottom of the Gateway.

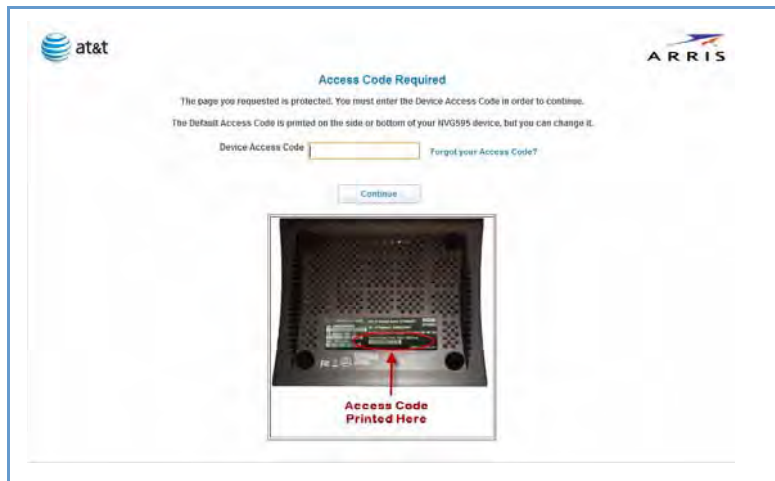

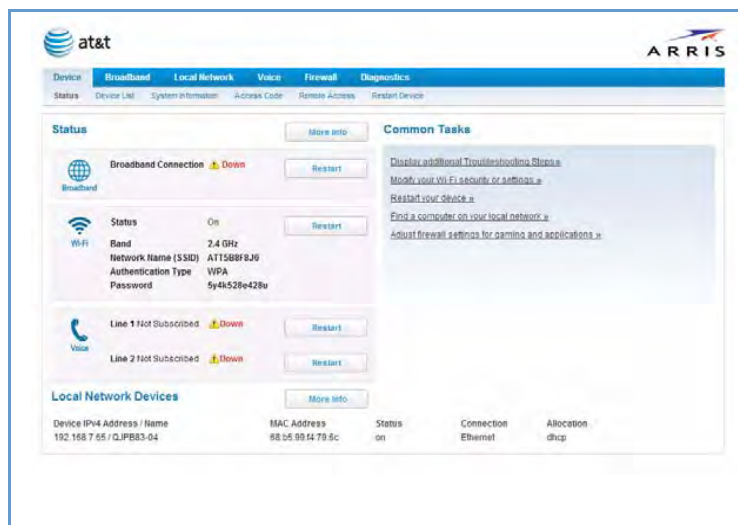

Enter your **Device Access Code** and click the [Continue](#) button.

The Device Status Page opens.



The Device Status displays the following information in the center section:

(icon)	Field	Description
 (Broadband)	Broadband Connection	'Waiting for ' is displayed while the Gateway is training. This should change to 'Up' within two minutes. 'Up' is displayed when the session is established. 'Down' indicates inability to establish a connection; possible line failure.
 (Wi-Fi)	Status	Your Wi-Fi signal may be ' On ' or ' Off '.
	Band	Indicates the current band the Wi-Fi is in, either 2.4 Ghz or 5.0 Ghz.
	Network ID (SSID)	This is the name or ID that is displayed to a client scan. The default SSID for the Gateway is attxxx where xxx is the last 3 digits of the serial number located on the side of the Gateway.
	Authentication Type	The type of Wi-Fi encryption security in use. May be Disabled, WPA or WEP, Default Key or Manual .
 (Voice)	Password	Wi-Fi network encryption key in use.
	Line 1	Indication of VoIP or other phone connection.
	Line 2	Indication of VoIP or other phone connection.

Some fields may or may not display, depending on your particular setup.

The [Diagnostics](#) button will connect you to the **Troubleshoot** page. See "[Diagnostics](#)" on page 80.

The right-hand frame displays some links to commonly performed tasks for easy access.

Common Tasks

- [Go to AT&T online support for troubleshooting and repair »](#)
- [Modify your Wireless security or settings »](#)
- [Restart your gateway »](#)
- [Find a computer on your home network »](#)
- [Adjust firewall settings for gaming and applications »](#)

- ◆ **Display additional troubleshooting steps - OR - Go to AT&T online support for troubleshooting and repair »**
This link will connect you to the **IP Diagnostics** page with help for troubleshooting and the AT&T Help Desk information. See "[IP Diagnostics Page Redirect](#)" on page 20.
- ◆ **Modify your Wi-Fi security or settings »**
This link will connect you to the **Wi-Fi** page. See "[Wi-Fi](#)" on page 41.
- ◆ **Restart your device »**
This link will connect you to the **Restart Device** page. See "[Restart Device](#)" on page 31.
- ◆ **Find a computer on your Local Network »**
This link will connect you to the **Device List** page. See "[Device List](#)" on page 25.
- ◆ **Adjust firewall settings for gaming and applications »**
This link will connect you to the **NAT/Gaming** page. See "[NAT/Gaming](#)" on page 69.

Tab Bar

The tab bar is located at the top of every page, allowing you to move freely about the site.



The tabs reveal a succession of pages that allow you to manage or configure several features of your Gateway. Each tab is described in its own section.

Help

Help is provided in your Gateway. Help is available in the right hand frame on every page in the Web interface. If the **Show Help** button is displayed, click it to open the Help. If the **Hide Help** button is displayed click it to close the Help window.

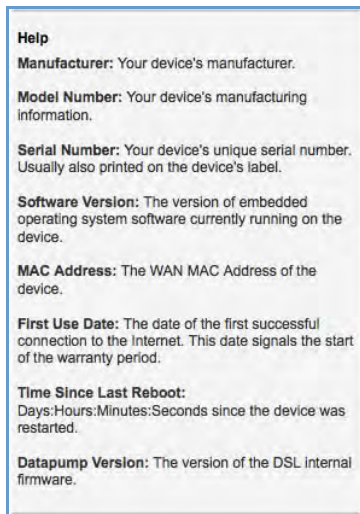

Here is an example:

The page shown here is displayed when you are on the **System Information** page.

Links Bar

The links bar at the top of each page allows you to configure different aspects of the features displayed on the page. For example, on the Home Summary page, the button bar is shown below:

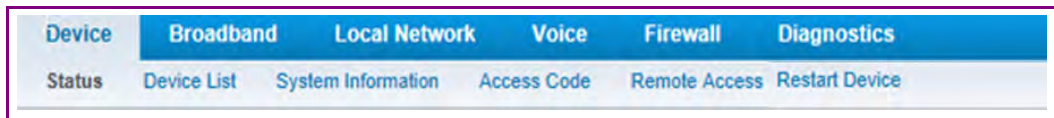



Click the links below to be taken to each section.

- ◆ ["Device Status page" on page 22](#)
- ◆ ["Device List" on page 25](#)
- ◆ ["System Information" on page 27](#)
- ◆ ["Access Code" on page 28](#)
- ◆ ["Remote Access" on page 29](#)
- ◆ ["Restart Device" on page 31](#)

Link: Device List

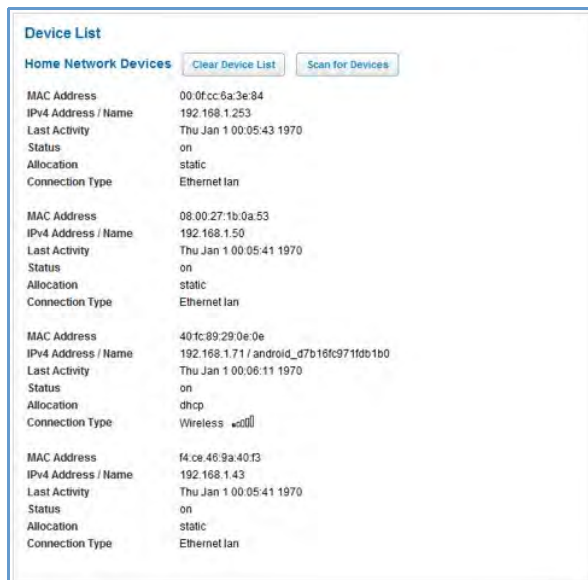
When you click the [Device List](#) link, the **Device List** page opens.



Home Network Devices	
MAC Address	00:0f:cc:6a:3e:84
IPv4 Address / Name	192.168.1.253
Last Activity	Thu Jan 1 00:05:43 1970
Status	on
Allocation	static
Connection Type	Ethernet lan
MAC Address	08:00:27:1b:0a:53
IPv4 Address / Name	192.168.1.50
Last Activity	Thu Jan 1 00:05:41 1970
Status	on
Allocation	static
Connection Type	Ethernet lan
MAC Address	40:fc:89:29:0e:0e
IPv4 Address / Name	192.168.1.71 / android_d7b16fc971fdb1b0
Last Activity	Thu Jan 1 00:06:11 1970
Status	on
Allocation	dhcp
Connection Type	Wireless 
MAC Address	f4:ce:46:9a:40:f3
IPv4 Address / Name	192.168.1.43
Last Activity	Thu Jan 1 00:05:41 1970
Status	on
Allocation	static
Connection Type	Ethernet lan

This view displays the following information:

Local Network Devices	
Local Network Devices	Displays the IPv4 Address, Network Name, and MAC Address of devices connected to this device on your local area network.
MAC Address	Client device's unique hardware address.
IPv4 Address / Name	Client device's IP address or device network name.
Last Activity	Date and time of last traffic for this client device
Status	May be off or on.
Allocation	Type of IP address assignment, for example, Static or DHCP.
Connection Type	Type of connection, for example, Ethernet or Wi-Fi

For Wi-Fi client connections, the Device List displays the familiar bars indicating signal strength, as follows:

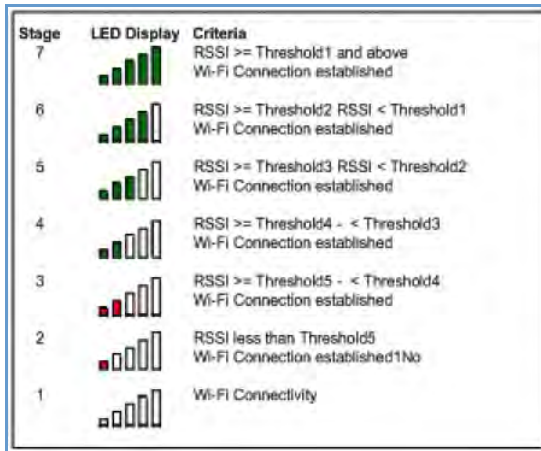

- ◆ Click the [Clear Device List](#) button to update the Local Network summary.
- ◆ Click the [Scan for Devices](#) button to seek out other devices that have been connected since the last Local Network summary update.

Link: System Information

When you click the [System Information](#) link, the **System Information** page opens.

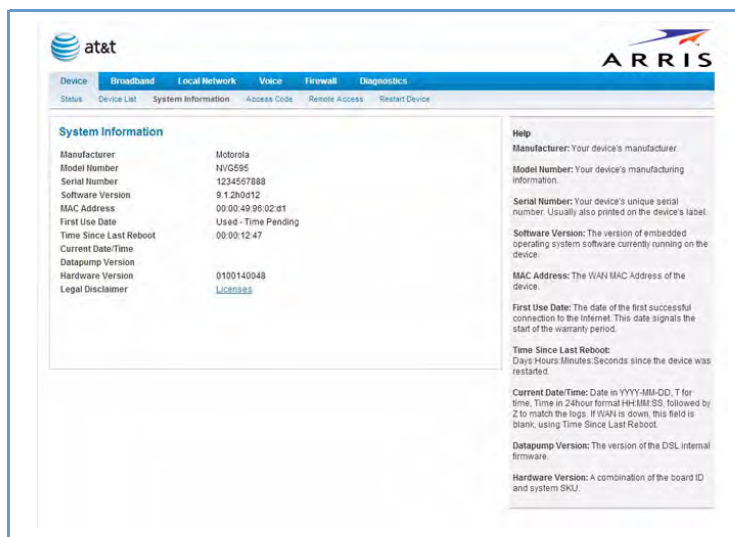

This view displays the following information:

System Information

Manufacturer	This is the manufacturer's identifier name.
Model Number	This is the manufacturer's model number.
Serial Number	This is the unique serial number of your Gateway.
Software Version	This is the version number of the current embedded software in your Gateway.
MAC Address	Unique hardware address of this Gateway unit.
First Use Date	Date and Time when the Gateway is first used. This field changes to the current date and time after a reset to factory defaults.
Time Since Last Reboot	Elapsed time since last reboot of the Gateway in days:hr:min:sec.
Current Date/Time	Current system date and time in days:hr:min:sec.
Datapump Version	Underlying operating system software datapump version
Legal Disclaimer	Clicking the Licenses link displays a listing of software copyright attributions also shown here: " Copyright Acknowledgments " on page 186.

Link: Access Code

Access to your Gateway is controlled through an account named **admin**. The default Admin password for your Gateway is the unique Access Code printed on the label on the side or bottom of your Gateway.

As the Admin, you can change this password to a different one of your own choosing between 8 and 20 characters long. The new password must also include two characters from any these categories: alpha, number, and special characters.

Example: "fru1tfl13s_likeabanana"

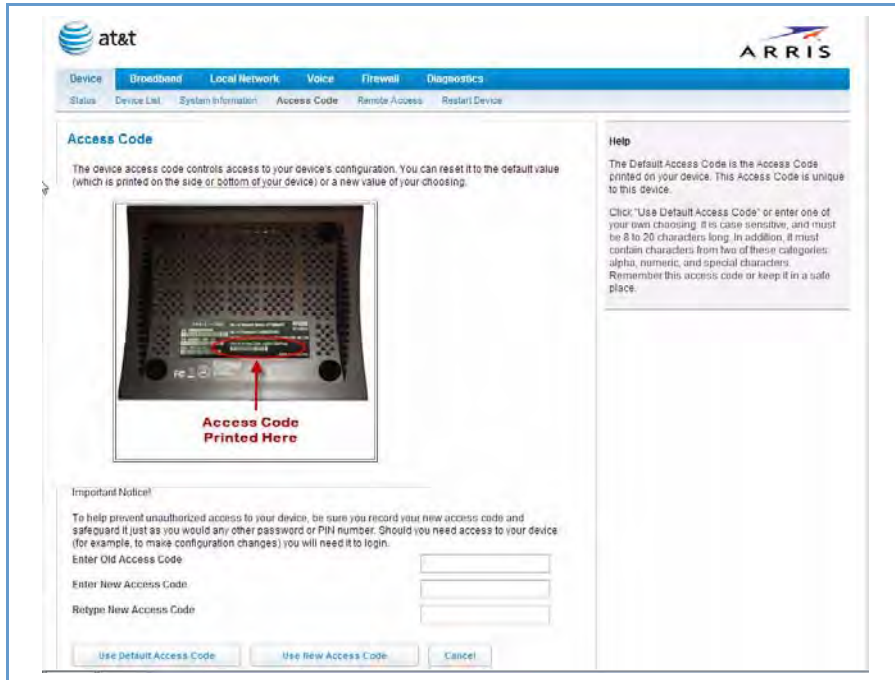

Enter your Old Access Code, your New Access Code, and click the [Use New Access Code](#) button. The new Access Code takes effect immediately.

You can always return to the original default password by clicking the [Use Default Access Code](#) button.

Link: Remote Access

The Remote Access page lets you grant access to your NVG595 Gateway to other users on the WAN. This function can be used for advanced troubleshooting or remote configuration.



WARNING

Enabling remote access allows anyone who knows or can determine the password, port ID, and URL (address) of your NVG595 Gateway to view any configuration settings or change the operation of your gateway.

If Remote access is not currently enabled, the Remote Access page will let you configure and enable it. If remote access has been enabled, the Remote Access Page will indicate that, and provides a button to disable it.

The screenshot shows the 'Remote Access' configuration page. It includes a navigation menu with tabs for Device, Broadband, Local Network, Voice, Firewall, and Diagnostics. Below the navigation menu are links for Status, Device List, System Information, Access Code, Remote Access, and Restart Device. The main content area is titled 'Remote Access' and contains instructions: 'To allow remote access to your NVG595 device, enter a password and click on the "Enable Remote Access" button below.' There are input fields for 'User Name' (set to 'tech'), 'Password', 'Port to use' (set to '27327'), and 'URL' (set to 'https://10.65.20.53'). Under 'Access Type', there are two radio buttons: 'Read only access' (selected) and 'Update access'. A blue 'Enable Remote Access' button is at the bottom left. A 'Help' section on the right explains password requirements and URL formatting.

To enable Remote Access:

1. Enter a password. This password must be at least 8 characters long, and must include at least two of the following types of characters:
 - ◆ alphabetic (letter) characters,
 - ◆ numeric (number) characters,
 - ◆ special characters (! @ # \$ % ^ & * , etc)
2. If necessary, set a custom port number for secure HTTP access to the NVG595 remote access session in the **Port Value** field.
3. Click the **Access Type** radio button to select the desired level of access:
 - ◆ **Read only access** - to allow the remote access session to view, but not change, the configuration and collected statistics of the gateway.
 - ◆ **Update access** - to allow the session to make changes to the gateway's configuration.
4. Click [Enable Remote Access](#).

The NVG595 updates the Remote Access page and displays the current remote access settings, shows the URL that a remote access client must use to connect to the remote access session, and provides a button for ending the remote access session. The remote access client will need to connect to the URL shown on the Remote Access page, and will need to log in with the username "tech" and the password configured when access was enabled.

To end (disable) an existing remote access configuration:

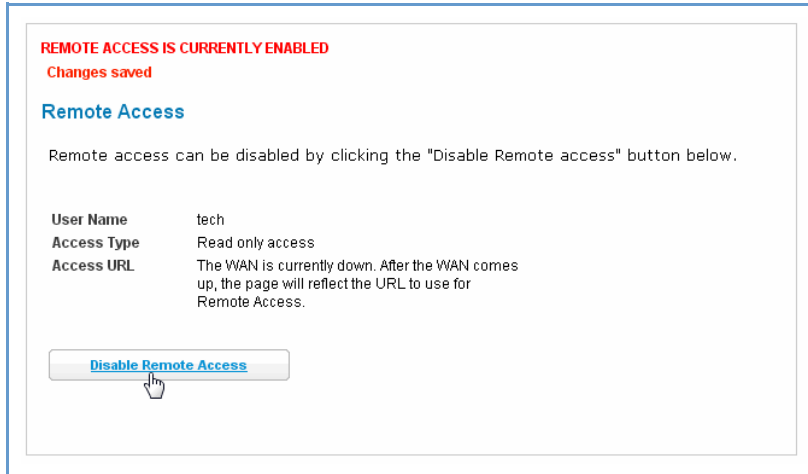

Click the [Disable Remote Access](#) button under the Access URL.

Link: Restart Device

When the Gateway is restarted, it will disconnect all users, initialize all its interfaces, and load the Operating System Software.

In some cases, when you make configuration changes, you may be required restart for the changes to take effect.

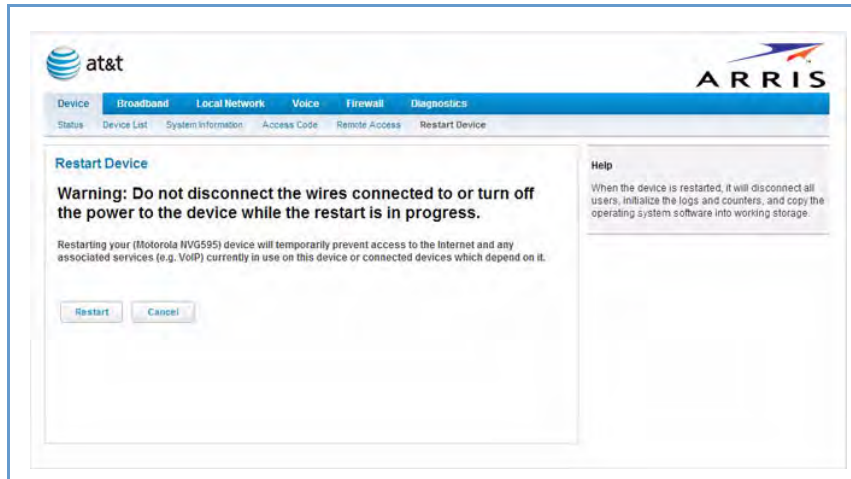

Broadband

When you click the [Broadband](#) tab, the **Broadband Status** page opens.

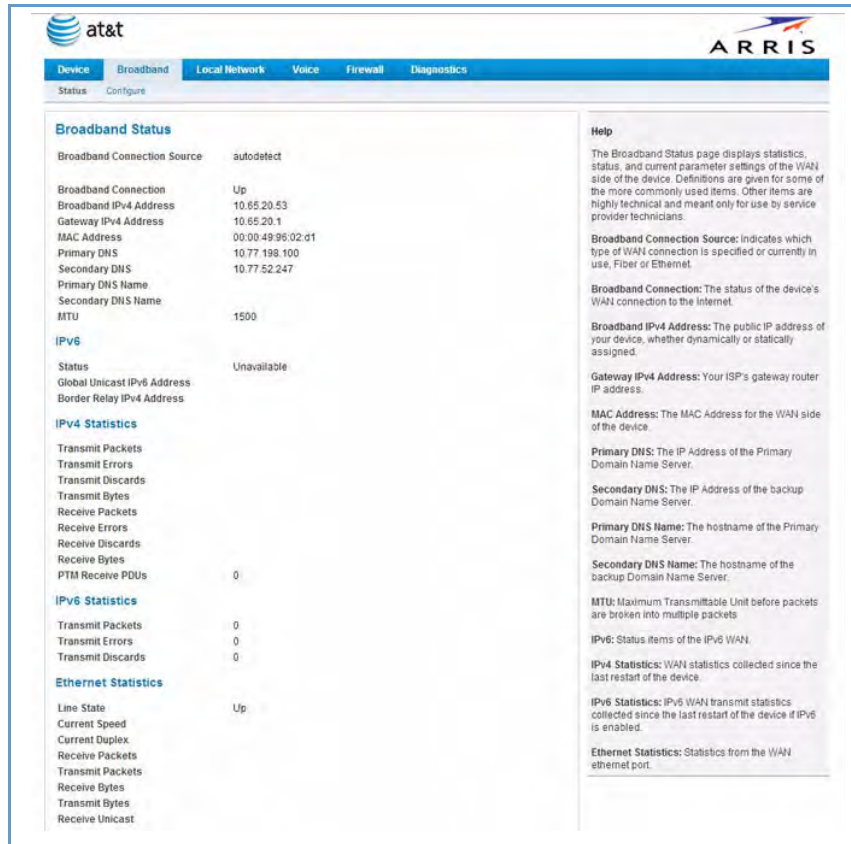

The **Broadband Status** page displays information about the Gateway's Ethernet WAN connection(s) to the Internet.

Broadband Status	
Broadband Connection Source	The communications technology providing the ARRIS® Gateway broadband uplink.
Broadband Connection	May be Up (connected) or Down (disconnected).
Broadband IPv4 Address	The public IP address of your device, whether dynamically or statically assigned.
Gateway IPv4 Address	Your ISP's gateway router IP address.
MAC Address	Your Gateway's unique hardware address identifier.
Primary DNS	The IP Address of the Primary Domain Name Server.
Secondary DNS	The IP Address of the backup Domain Name Server, if available.
Primary DNS Name	The name of the Primary Domain Name Server.
Secondary DNS Name	The name of the backup Domain Name Server, if available.
MTU	Maximum Transmittable Unit before packets are broken into multiple packets.
Ethernet Statistics (Ethernet WAN)	
Line State	Up or Down

Current Speed	Line speed
Current Duplex	Full- or Half-duplex
Receive Packets	Number of packets received
Transmit Packets	Number of packets sent
Receive Bytes	Number of bytes received
Transmit Bytes	Number of bytes sent
Receive Unicast	Receive Unicast statistics
Transmit Unicast	Transmit Unicast statistics
Receive Multicast	Receive Multicast statistics
Transmit Multicast	Transmit Multicast statistics
Receive Drops	Received packets dropped
Transmit Drops	Sent packets dropped
Receive Errors	Count of received errored packets that were fixed successfully without a retry.
Transmit Errors	Number of times data packets have had to be resent due to errors in transmission.
Collisions	Count of packet collisions.

IPv6

Status	May be Enabled or Unavailable .
Global Unicast IPv6 Address	The public IPv6 address of your device, whether dynamically or statically assigned.
Border Relay IPv4 Address	The public IPv4 address of your device.

IPv4 Statistics

Transmit Packets	IPv4 packets transmitted.
Transmit Errors	Errors on IPv4 packets transmitted.
Transmit Discards	IPv4 packets dropped.

IPv6 Statistics

Transmit Packets	IPv6 packets transmitted.
Transmit Errors	Errors on IPv6 packets transmitted.
Transmit Discards	IPv6 packets dropped.

Link: Configure

When you click the [Configure](#) link, the Broadband **Configure** screen opens. Here you can reconfigure your type of broadband connection should it change in the future.

Configure

Broadband Source Override

Maximum allowable MTU

Help

Broadband Source Override: This field indicates the type of WAN interface in use.

- Auto will cause the system to attempt to figure out by trial and error what type of line is connected.
- Fiber will tell the system fiber is or will be connected.
- Ethernet will tell the system ethernet is or will be connected.

MTU: The MTU (Maximum Transmittable Unit) indicates the maximum packet size before the device will split a packet into multiple packets.

- ◆ **Broadband Source Override** - Auto (automatically detected), Fiber, or Ethernet.
- ◆ **Maximum allowable MTU** - The WAN connection is automatically configured. However, you can adjust the Maximum Transmittable Unit value, if your service provider suggests it. The default 1500 is the maximum value, but some services require other values. 1492 is common.

If you make any change here, click the [Save](#) button.

Link: Fiber Status

When you click the [Fiber Status](#) link, the **Fiber Status** screen opens.

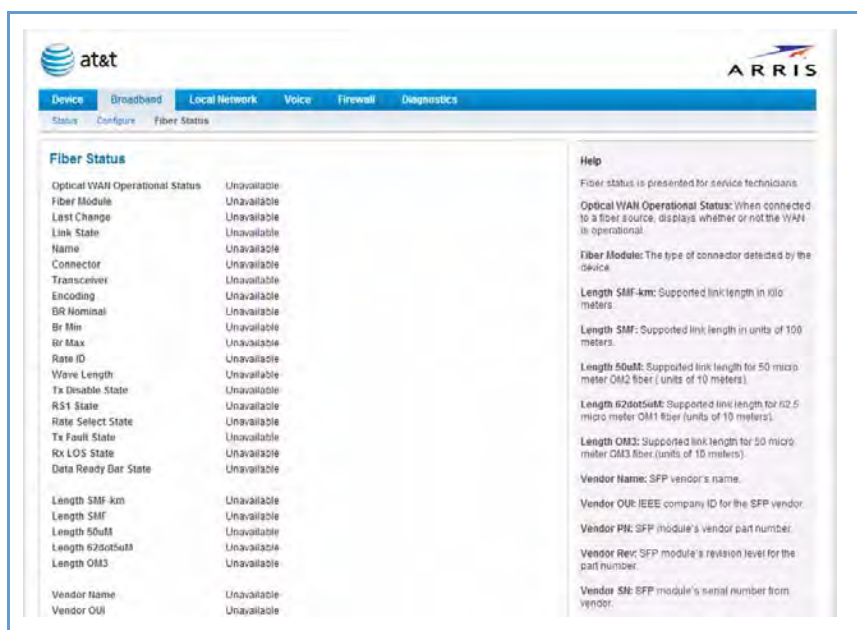

The Fiber Status view provides information about the device's Fiber Ethernet WAN connection.

Fiber Status

Optical WAN Operational Status	When connected to a fiber source, displays whether or not the WAN is operational.
Fiber Module	The type of connector detected by the device.
Length SMF-km	Supported link length in kilometers.
Length SMF	Supported link length in units of 100 meters.
Length 50uM	Supported link length for 50 micrometer OM2 fiber (units of 10 meters).
Length 62dot5uM	Supported link length for 62.5 micrometer OM1 fiber (units of 10 meters).
Length OM3	Supported link length for 50 micrometer OM3 fiber (units of 10 meters).
Vendor Name	SFP vendor's name.
Vendor OUI	IEEE company id for the SFP vendor.
Vendor PN	SFP module's vendor part number.
Vendor Rev	SFP module's revision level for the part number.
Vendor SN	SFP module's serial number from the vendor.
Vendor Date Code	In format <yyymmddxx> where "xx" is vendor specific and may be blank
OPT Cooled Trans	Whether the transceiver is cooled or uncooled.
OPT Powerlvl	Power level operation of either 1 or 2.
OPT Linear Rcvr	Indicates if the Receiver is a conventional or Linear receiver.

OPT Rate Select	Indicates whether Rate Select is implemented. 1 = implemented, 0 = not implemented.
OPT Tx Disable	Ability to disable the serial output 1 = implemented, 0 = not implemented.
OPT Tx Fault	TX_FAULT is implemented, 1 = implemented, 0 = not implemented.
OPT Inverted LOS	Also known as signal detect, 1 = implemented, 0 = not implemented.
OPT LOS	Loss of signal. 1 = implemented, 0 = not implemented.
DMC Type Legacy	Reserved. Always 0
DMC Type Implemented	Diag monitoring, 1 = implemented, 0 = not implemented.
DMC Type Internal Cal	The device is internally calibrated.
DMC Type External Cal	The device is externally calibrated.
DMC Type Rx Avg Pwr	The type of power measurement. Either Modulation Amplitude method or Average power method.
EOC Alarm implemented	1 = implemented, 0 = not implemented.
EOC Soft Tx Disable	TX_DISABLE control and monitoring, 1 = implemented, 0 = not implemented.
EOC Soft Tx Fault	TX_FAULT monitoring, 1 = implemented, 0 = not implemented.
EOC Soft Rx LOS	RX_LOS monitoring, 1 = implemented, 0 = not implemented.
EOC Soft Rate Select	Soft Rate_Select control and monitoring, 1 = implemented, 0 = not implemented.
SFF 8079 App Select	Application select implemented from the standard SFF 8079, 1 = implemented, 0 = not implemented.
SFF 8431 Rate Select	Rate select implemented from standard 8431, 1 = implemented, 0 = not implemented..
SFF Ver Compliance	Reference 3.12 table in SFF 8742. Rev 9.3 or rev 9.5.

Local Network

When you click the [Local Network](#) tab, the **Local Network Status** page opens.

The screenshot shows the 'Local Network Status' page. At the top, there are logos for 'at&t' and 'ARRIS'. Below the logos is a navigation bar with tabs: 'Device', 'Broadband', 'Local Network', 'Voice', 'Firewall', and 'Diagnostics'. Under 'Local Network', there are sub-tabs: 'Status', 'Configure', 'Wi-Fi', 'MAC Filter', 'Wi-Fi Scan', 'Subnets & DHCP', and 'IP Allocation'. The main content area is divided into several sections:

- Local Network Status:** A table showing various settings:

Device IPv4 Address	192.168.7.254
DHCPv4 Netmask	255.255.255.0
DHCPv4 Start Address	192.168.7.64
DHCPv4 End Address	192.168.7.253
DHCP Leases Available	189
DHCP Leases Allocated	1
DHCP Primary Pool	Private
Secondary Subnet	Disabled
Public Subnet	
Cascaded Router Status	Disabled
IP Passthrough Status	Off (private IP address)
- Interfaces:** A table showing the status of network interfaces:

Interface	Status	Active Devices	Inactive Devices
Ethernet	Enabled	1	0
Wi-Fi	Enabled	0	0
- IPv6:** A table showing IPv6 settings:

Status	Unavailable
Global IPv6 Address	/
Link-Local IPv6 Address	
Router Advertisement Prefix	
IPv6 Delegated LAN Prefix	/64
- IPv4 Statistics:** A table showing network statistics:

Transmit Packets	29259
Transmit Errors	0
Transmit Discards	0
Receive Packets	31125
Receive Errors	0
Receive Discards	0
- Help:** A section providing definitions for various terms used in the status page, such as 'Device IPv4 Address', 'DHCPv4 Netmask', 'DHCPv4 Start Address', 'DHCPv4 End Address', 'DHCP Leases Available', 'DHCP Leases Allocated', 'DHCP Primary Pool', 'Secondary Subnet', 'Public Subnet', and 'Cascaded Router Status'.

The **Local Network Status** page displays information about the Gateway's local area network.

If you click the [Run Congestion Detection](#) button, the device will generate statistics for each of the 11 channels available, displaying:

- ◆ Channel number
- ◆ AP (Access Point) Count
- ◆ Congestion Score (1 - 10) - note that higher values mean lower congestion.

The Wi-Fi congestion feature provides simple data to the user to show the level of network congestion in each Wi-Fi channel. This data can be used to determine router placement or to determine which channels to avoid.

The display currently tells the user how many Access Points (APs) are active within each channel, and provides a score of 1 - 10 to indicate how clear the channel is. A higher score indicates less congestion in a channel, so a channel with a 10 indicates a channel extremely clear of Wi-Fi traffic and noise. Alternatively, a score of 1 indicates more severe congestion in a channel.

You can clear the current statistics information by clicking the [Clear Statistics](#) button. This view provides the following information.

Local Network Status

Device IPv4 Address	The Gateway's own IP address on the network.
DHCP Netmask	The Gateway's own netmask on the network.
DHCPv4 Start Address	The starting IP address of the DHCP range served by the Gateway.
DHCPv4 End Address	The ending IP address of the DHCP range served by the Gateway.
DHCP Leases Available	The number of IP addresses of the DHCP range available to be served by the Gateway.
DHCP Leases Allocated	The number of IP addresses of the DHCP range currently being served by the Gateway.
DHCP Primary Pool	Source pool of the IP addresses served by the Gateway, Public or Private.

IPv6

Status	May be Enabled or Unavailable .
Global IPv6 Address	The public IPv6 address of your device, whether dynamically or statically assigned.
Link-local IPv6 Address	The private IPv6 address of your device, whether dynamically or statically assigned.
Router Advertisement Prefix	The IPv6 prefix to include in router advertisements.
IPv6 Delegated LAN Prefix	The IPv6 network address prefix that identifies the gateway network.

IPv4 Statistics

Transmit Packets	IPv4 packets transmitted.
Transmit Errors	Errors on IPv4 packets transmitted.
Transmit Discards	IPv4 packets dropped.

IPv6 Statistics

Transmit Packets	IPv6 packets transmitted.
Transmit Errors	Errors on IPv6 packets transmitted.
Transmit Discards	IPv6 packets dropped.

Wi-Fi Status

Wi-Fi Radio Status	Indicates whether the Wi-Fi radio is Enabled or Disabled .
Network Name (SSID)	This is the name or ID that is displayed to a client scan. The default SSID for the Gateway is attxxx where xxx is the last 3 digits of the serial number located on the side of the Gateway.
Hide Network Name SSID	May be either On or Off . If On, your SSID will not appear in a client scan.
Band	The currently selected Wi-Fi band, either 2.4 Ghz or 5.0 Ghz
Wi-Fi Security	The type of Wi-Fi encryption security in use. May be Disabled , WPA or WEP , Default Key or Manual .
Password	The Wi-Fi password if security is WEP or WPA.
Mode	The Wi-Fi standard in operation on this device..
Bandwidth	The capacity of the Wi-Fi LAN to carry traffic in megahertz.
Current Radio Channel	The radio channel that your Wi-Fi network is broadcasting on.
Radio Channel Selection	May be set to automatic or manually selected. Automatic indicates that the device selects the best channel for its environment. Fixed indicates that the user has specified the desired channel.
MAC Address Filtering	On indicates that the device is inspecting MAC addresses before connecting Wi-Fi clients.
Power Level	May be adjusted up to 100%, lower if multiple Wi-Fi access points are in use, and might interfere with each other.

Wi-Fi MAC Address	Shows the information of the MAC address of the Wi-Fi subsystem.
-------------------	--

Wi-Fi Network Statistics

Transmit Bytes	Number of bytes transmitted on the Wi-Fi network.
Receive Bytes	Number of bytes received on the Wi-Fi network.
Transmit Packets	Number of packets transmitted on the Wi-Fi network.
Receive Packets	Number of packets received on the Wi-Fi network.
Transmit Error Packets	This is the number of errors on packets transmitted on the Wi-Fi network.
Receive Error Packets	This is the number of errors on packets received on the Wi-Fi network.
Transmit Discard Packets	This is the number of packets transmitted on the Wi-Fi network that were dropped.
Receive Discard Packets	This is the number of packets received on the Wi-Fi network that were dropped.

LAN Ethernet Statistics

State	up or down
Transmit Speed	This is the maximum speed of which the port is capable.
Transmit Packets	This is the number of packets sent out from the port.
Transmit Bytes	This is the number of bytes sent out from the port.
Transmit Dropped	This is the number of packets sent out from the port that were dropped.
Transmit Errors	This is the number of errors on packets sent out from the port.
Receive Packets	This is the number of packets received on the port.
Receive Bytes	This is the number of bytes received on the port.
Receive Unicast	This is the number of unicast packets received on the port.
Receive Multicast	This is the number of multicast packets received on the port.
Receive Dropped	This is the number of packets received on the port that were dropped.
Receive Errors	This is the number of errors on packets received on the port.

The links at the top of the Local Network page access a series of pages to allow you to configure and monitor features of your device. The following sections give brief descriptions of these pages.

- ◆ [“Configure” on page 40](#)
- ◆ [“Wi-Fi” on page 41](#)
- ◆ [“MAC Filtering” on page 46](#)
- ◆ [“Wi-Fi Scan” on page 47](#)
- ◆ [“Subnets & DHCP” on page 48](#)
- ◆ [“IP Allocation” on page 50](#)

Link: Configure

When you click the [Configure](#) link, the **Configure** page for the Ethernet LAN opens.

	Port 1	Port 2	Port 3	Port 4
Ethernet	Auto	Auto	Auto	Auto
MDI-X	Auto	Auto	Auto	Auto

[Save](#) [Cancel](#)

For each **Ethernet** Port, 1 through 4, you can select:

- ◆ **Ethernet** – Auto (the default self-sensing rate), 10M full- or half-duplex, 100M full- or half-duplex, or 1G full- or half-duplex.
- ◆ **MDI-X** – Auto (the default self-sensing crossover setting), **off**, or **on**.

Click the [Save](#) button.

Link: Wi-Fi

When you click the [Wi-Fi](#) link the Wi-Fi page opens. The Wi-Fi page displays the status of your Wi-Fi LAN elements.

The screenshot shows the AT&T ARRIS web interface for Wi-Fi configuration. The main content area is titled 'Wi-Fi' and contains several configuration fields:

- Wi-Fi Operation:** On (dropdown)
- Network Name (SSID):** ATT7888 (text input)
- Hide Network Name (SSID):** Off (dropdown)
- Band:** 2.4GHz (dropdown)
- Security:** WPA - Default Password (dropdown)
- WPA Version:** Both (dropdown)
- WEP Password Length:** 10 characters (40/64 bits) (dropdown)
- Network Password:** 1111111111 (text input)
- Mode:** B/G/N (dropdown)
- Bandwidth:** 20MHz (dropdown)
- Channel:** Automatic (dropdown)
- Power Level (1-100%):** 100 (text input)
- Wi-Fi Protected Setup (WPS):** Off (dropdown)

At the bottom of the configuration area are 'Save' and 'Cancel' buttons. Below that is a section for WPS PIN with a 'Submit' button. A 'Help' section on the right provides detailed information for each setting.

The Wi-Fi page's center section contains a summary of the Wi-Fi Access Point's configuration settings and operational status.

Summary Information	
Field	Status and/or Description
General Information	
Wi-Fi Operation	May be either On or Off .
Network Name (SSID)	This is the name or ID that is displayed to a client scan. The default SSID for the Gateway is attxxx where xxx is the last 3 digits of the serial number located on the side of the gateway.
Hide Network Name SSID	May be either Off or On . If On, your SSID will not appear in a client scan.
Band	Choose between 2.4 and 5.0 Ghz. If 5.0 is chosen, all devices connecting to this device must support 802.11n.
Security	The type of Wi-Fi encryption security in use. May be OFF-No Privacy , WPA-PSK or WEP, Default Key or Manual .
WPA Version	If WPA is selected, may be Both , WPA-1 , or WPA-2 .
WEP Password Length	May be 10 characters for 40/64-bit, or 26 characters for 128-bit WP encryption.

Network Password	Here you can enter a manual encryption key.
Mode	Will be 802.11 B only, 802.11 G only, 802.11 N only, 802.11 B/G or 802.11 B/G/N . These will vary depending on the Band selected.
Bandwidth	The capacity of the Wi-Fi LAN to carry traffic in Megahertz, 20 or 40 .
Channel	The radio channel that your Wi-Fi network is broadcasting on. This should be left at the default Automatic .
Power Level	May be adjusted up to 100%, lower if multiple Wi-Fi access points are in use, and might interfere with each other.
Wi-Fi Protected Setup (WPS)	May be either On or Off .

- ◆ The **Wi-Fi Operation** function is automatically enabled by default. If you uncheck the checkbox, the Wi-Fi Options are disabled, and the Wi-Fi Access Point will not provide or broadcast its Wi-Fi LAN services.
- ◆ **Network Name (SSID)** – preset to a number unique to your unit. You can either leave it as is, or change it by entering a freeform name of up to 32 characters, for example “Hercule’s Wi-Fi LAN”. On client PCs’ software, this might also be called the Network Name. The Wi-Fi ID is used to identify this particular Wi-Fi LAN. Depending on their operating system or client Wi-Fi card, users must either:
 - select from a list of available Wi-Fi LANs that appear in a scanned list on their client
 - or enter this name on their clients in order to join this Wi-Fi LAN.
- ◆ **Hide Network Name SSID** – If enabled, this mode hides the Wi-Fi network from the scanning features of Wi-Fi client computers. Hiding the SSID prevents casual detection of your Wi-Fi network by unwanted neighbors and passers-by. The gateway WLAN will not appear when clients scan for access points. If Hide SSID is enabled, you must remember and enter your SSID when adding clients to the Wi-Fi LAN.



NOTE:

While hiding the SSID may prevent casual discovery of your Wi-Fi network, enabling security is the only true method of securing your network.

- ◆ **Security, WPA Version, WEP Password Length, Password** – see [“Wi-Fi Security” on page 44.](#)
- ◆ **Mode** – The pull-down menu allows you to select and lock the Gateway into the Wi-Fi transmission mode you want: **B/G/N**, **B-only**, **B/G**, **G-only**, or **N-only**.
For compatibility with clients using 802.11b (up to 11 Mbps transmission), 802.11g (up to 20+ Mbps), 802.11a (up to 54 Mbit/s using the 5 GHz band), or 802.11n (from 54 Mbit/s to 600 Mbit/s with the use of four spatial streams at a channel width of 40 MHz), select **B/G/N**. To limit your Wi-Fi LAN to one mode or the other, select **G-only**, **N-only**, or **B-only**, or some combination that applies to your setup.



NOTE:

If you choose to limit the operating mode to 802.11b or 802.11g only, clients using the mode you excluded will not be able to connect.

- ◆ **Bandwidth** – use a single 20MHz channel (**20MHz** setting) , or combine two 20MHz channels (**40MHz** setting) to increase data speeds. The 40MHz mode may only be selected if the **Mode** setting is 801.11 B/G/N or 802.11 N-Only. To prevent interference with lower bandwidth clients, the Wi-Fi network will revert to 20MHz operation if non-compatible (802.11B, 802.11G, or 20MHz 802.11N) clients are detected.
- ◆ **Channel** (1 through 11, for North America) on which the network will broadcast. This is a frequency range within the 2.4Ghz band. The **Automatic** setting allows the Wi-Fi Access Point to determine the best channel to broadcast automatically.
- ◆ **Power Level** – Sets the Wi-Fi transmit power, scaling down the Wi-Fi Access Point’s Wi-Fi transmit coverage by lowering its radio power output. Default is **100%** power. Transmit power settings are useful in large venues with multiple Wi-Fi routers where you want to reuse channels. Since there are only three non-overlapping channels in the 802.11 spectrum, it helps to size the Wi-Fi Access Point’s cell to match the location. This allows you to install a router to cover a small “hole” without conflicting with other routers nearby.
- ◆ **Wi-Fi Protected Setup (WPS)** is a not a security protocol. It is an easier way to add and securely configure new clients to your WLAN.
By default, Privacy is set to Wi-Fi Protected Access (WPA-PSK) with a 12 character security key. WPS allows you to securely share your exact security configuration with a new client that you are adding to the WLAN, without needing to look up and type this security key. Clients may be added using the WPS button on the router, or by entering the client WPS PIN on this page.

Not all client Wi-Fi devices support WPS. Refer to their documentation.
Enter your **WPS PIN** and click the [Submit](#) button.
Follow the instructions that came with your Wi-Fi client.

Wi-Fi Security

By default, Wi-Fi Security is set to **WPA-PSK** with a pre-defined **WPA-Default Key (Wi-Fi Protected Access Pre-Shared Key)**.

Other options are available from the **Security** pull-down menu:

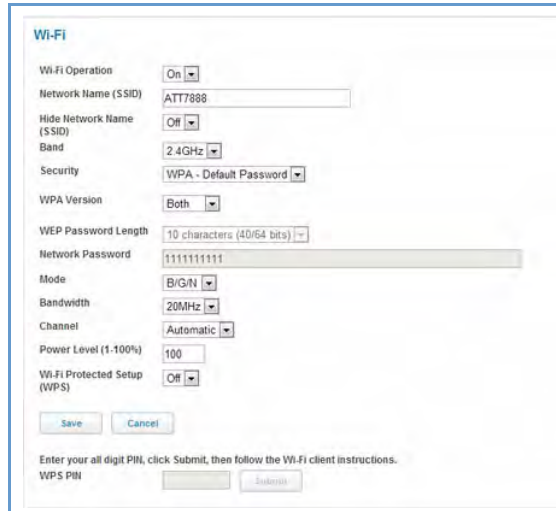

The screenshot shows a web interface for configuring Wi-Fi settings. The 'Wi-Fi' section is active. Under 'Wi-Fi Operation', it is set to 'On'. 'Network Name (SSID)' is 'ATT7888'. 'Hide Network Name (SSID)' is 'Off'. 'Band' is '2.4GHz'. 'Security' is 'WPA - Default Password'. 'WPA Version' is 'Both'. 'WEP Password Length' is '10 characters (40/64 bits)'. 'Network Password' is '1111111111'. 'Mode' is 'B/G/N'. 'Bandwidth' is '20MHz'. 'Channel' is 'Automatic'. 'Power Level (1-100%)' is '100'. 'Wi-Fi Protected Setup (WPS)' is 'Off'. There are 'Save' and 'Cancel' buttons. Below the form, there is a note: 'Enter your all digit PIN, click Submit, then follow the Wi-Fi client instructions.' with a 'WPS PIN' field and a 'Submit' button.

- ◆ **WEP - Manual:** WEP Security is a Privacy option that is based on encryption between the Router and any PCs (“clients”) you have with Wi-Fi cards. For this encryption to work, both your Wi-Fi Access Point and each client must share the same Wi-Fi ID (SSID), and both must be using the same encryption keys. See [“WEP-Manual” on page 45.](#)



NOTE:

WEP is a less current and less secure authentication method than WPA-PSK. It may be required if your Wi-Fi clients do not support WPA.

- ◆ **WPA-PSK:** allows you to enter your own key, the most secure option for your Wi-Fi network. The key can be between 8 and 63 characters, but for best security it should be at least 20 characters. If you select **WPA-PSK** as your privacy setting, the **WPA Version** pull-down menu allows you to select the WPA version(s) that will be required for client connections. Choices are:
 - Both**, for maximum interoperability,
 - WPA-1**, for backward compatibility,
 - WPA-2**, for maximum security.All clients must support the version(s) selected in order to successfully connect.
Be sure that your Wi-Fi client adapter supports this option. Not all Wi-Fi clients support WPA-PSK.
- ◆ **OFF - No Privacy:** This mode disables privacy on your network, allowing any Wi-Fi users to connect to your Wi-Fi LAN. Use this option if you are using alternative security measures such as VPN tunnels, or if your network is for public use.

Click the [Save](#) button.

WEP-Manual

You can provide a level of data security by enabling WEP (Wired Equivalent Privacy) for encryption of network data. You can enable 40- or 128-bit WEP Encryption (depending on the capability of your client Wi-Fi card) for IP traffic on your LAN.

WEP - Manual allows you to enter your own encryption keys manually. This is a difficult process, but only needs to be done once. Avoid the temptation to enter all the same characters.

Password Length: The pull-down menu selects the length of each encryption key. The longer the key, the stronger the encryption and the more difficult it is to break the encryption.

Password: You enter a key using hexadecimal digits. For 40/64-bit encryption, you need ten digits; 26 digits for 128-bit WEP. Hexadecimal characters are 0 – 9, and a – f.

Examples:

- ◆ 40 bits: 02468ACE02
- ◆ 128 bits: 0123456789ABCDEF0123456789

Any WEP-enabled client must have an identical key of the same length as the Router, in order to successfully receive and decrypt the traffic. Similarly, the client also has a 'default' key that it uses to encrypt its transmissions. In order for the Router to receive the client's data, it must likewise have the identical key of the same length.

Click the [Save](#) button.

Link: MAC Filtering

When you click the [MAC Filtering](#) link the **MAC Filtering** page opens.

MAC Filtering

MAC Filtering Type: Disabled

Save Cancel

MAC Filter List

No MAC Filter entries have been defined

MAC Filter Entry

Please choose from the list of MACs or enter one manually and click "Add"

MAC Address: List of MACs: Manual Entry:

No MACs Found

Add

MAC Filtering allows you to specify which client PCs are allowed to join the Wi-Fi LAN by unique hardware (MAC) address.

- ◆ To enable this feature, select **Blacklist** or **Whitelist** from the **MAC Filtering Type** menu. **Blacklist** means that only MAC addresses you specify will be denied access; **Whitelist** means that only MAC addresses you specify will be allowed access.
- ◆ You add Wi-Fi clients that you want to Whitelist or Blacklist for your Wi-Fi LAN by selecting them from the **List of MACs** or by entering the MAC addresses in the **Manual Entry** field provided.
- ◆ Click the [Add](#) button.

Your entries will be added to a list of clients that will be either authorized (Whitelisted) or disallowed (Black-listed) depending on your selection.

MAC	Delete
00:16:cb:39:a9:78	Delete
00:18:cd:34:b8:69	Delete
00:19:ce:35:c7:68	Delete

- ◆ Click the [Save](#) button.

You can **Add** or **Delete** any of your entries later by returning to this page.

Link: Wi-Fi Scan

Your device automatically checks for the best channel to broadcast Wi-Fi services. However, in some cases it may be useful to switch to a different channel on which the network will broadcast.

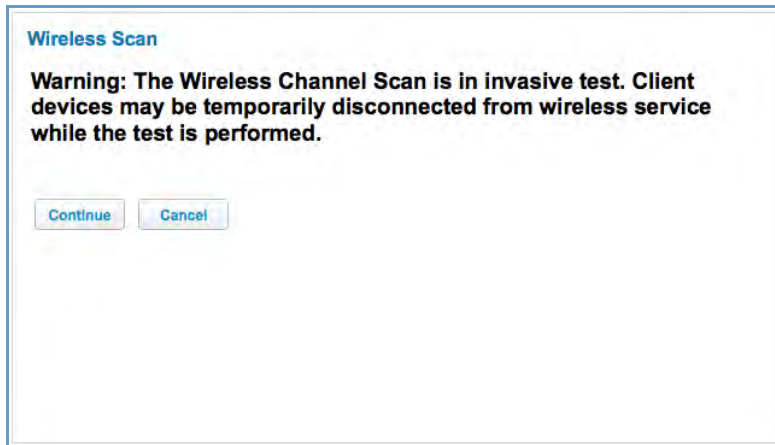

Channel selection depends on government regulated radio frequencies that vary from region to region. Channel selection can have a significant impact on performance, depending on other Wi-Fi activity close to this device. You need not select a channel at any of the computers on your Wi-Fi network, they will automatically scan available channels seeking a Wi-Fi device broadcasting on the SSID for which they are configured.

This scan will disconnect any Wi-Fi client devices from the Wi-Fi network.

If you want to scan for a different channel on which the device will broadcast, click the [Continue](#) button.

Link: Subnets & DHCP

When you click the [Subnets & DHCP](#) link, the **Subnets & DHCP** page opens.

The screenshot shows the 'Subnets & DHCP' configuration page. It includes a navigation bar with tabs for Device, Broadband, Local Network, Voice, Firewall, and Diagnostics. The 'Subnets & DHCP' tab is active. The page is organized into several sections: 'Private LAN Subnet' with fields for Device IPv4 Address (192.168.7.254) and Subnet Mask (255.255.255.0); 'DHCP Server' with a dropdown for DHCP Server Enable (set to 'On'), DHCPv4 Start Address (192.168.7.64), DHCPv4 End Address (192.168.7.64), and DHCP Lease (1:0:0:0); 'Public Subnet' with a dropdown for Public Subnet Mode (set to 'Off'), a checkbox for Allow Inbound Traffic (set to 'Off'), Public IPv4 Address, Public Subnet Mask (255.255.255.0), DHCPv4 Start Address, DHCPv4 End Address, and radio buttons for Primary DHCP Pool (set to 'Private'); and 'Cascaded Router' with a dropdown for Cascaded Router Enable (set to 'Off'), Cascaded Router Address, Network Address, and Subnet Mask (255.255.255.248). A 'Save' button and a 'Cancel' button are at the bottom left. A 'Help' sidebar on the right provides detailed explanations for each field.

The Server configuration determines the functionality of your DHCP Settings. This functionality enables the Gateway to assign a single IP address of 192.168.7.64 through 192.168.7.253 to the LAN.

Private LAN Subnet

- ◆ **Device IPv4 Address:** The IP address of your Gateway as seen from the LAN
- ◆ **Subnet Mask:** Subnet mask of your LAN

DHCP Server

- ◆ **DHCP Server Enable:** If you have a dedicated source of DHCP assigned addresses on your LAN, choose **off** from the pull-down menu. By default the NVG595 will act as a DHCP server and should be set to **On**.
- ◆ **DHCPv4 Start Address:** First IP address in the range being served to your LAN by the Gateway's DHCP server
- ◆ **DHCPv4 End Address:** Last IP address in the range being served to your LAN by the Gateway's DHCP server
- ◆ **DHCP Lease:** Specifies the default length for DHCP leases issued by the Router. Enter lease time in dd:hh:mm:ss (days/hours/minutes/seconds) format.

Public Subnet

- ◆ **Public Subnet Enable:** If you select On from the pull-down menu, you can enable a second subnet to distribute public addresses to DHCP clients; this means that IP addresses assigned to LAN clients will be public addresses
- ◆ **Public IPv4 Address:** The IP address of your Gateway as seen from the WAN
- ◆ **Public Subnet Mask:** Public subnet mask
- ◆ **DHCPv4 Start Address:** First IP address in the range being served from a DHCP public pool.
- ◆ **DHCPv4 End Address:** Last IP address in the range being served from a DHCP public pool.
- ◆ **Primary DHCP Pool:** Choose the source of the DHCP pool IP address assignment by selecting either the **Private** (local to your LAN) or **Public** (assigned remotely) radio button.

Cascaded Router

- ◆ **Cascaded Router Enable:** If you have another router behind this Gateway, choose **On** from the pull-down menu.
- ◆ **Cascaded Router Address:** If you chose On from the pull-down menu, enter the IP address of the router you are using behind this Gateway in the LAN Private IP subnet range.
- ◆ **Network Address:** If you chose On from the pull-down menu, enter the Network Address that defines the range of IP addresses available to clients of the router you are using behind this Gateway.
- ◆ **Subnet Mask:** If you chose On from the pull-down menu, enter the subnet mask for the Network Address that defines the range of IP addresses available to clients of the router you are using behind this Gateway

If you make any changes here, click the [Save](#) button, and if prompted, restart the Gateway.

Link: IP Allocation

When you click the [IP Allocation](#) link, the IP allocation page opens.

The screenshot shows the ARRIS web interface for IP Allocation. The top navigation bar includes tabs for Device, Broadband, Local Network, Voice, Firewall, and Diagnostics. Under Diagnostics, there are sub-tabs for Status, Configure, Wi-Fi, MAC Filtering, Wi-Fi Scan, Subnets & DHCP, and IP Allocation. The IP Allocation page displays a table with the following data:

IPv4 Address / Name	MAC Address	Status	Allocation	Action
192.168.7.65 / QJPB93-04	68:b5:99:f4:79:6c	on	DHCP Allocation	Allocate

To the right of the table is a 'Help' section with the following text:

The IP Allocation table lists DHCP clients and IP Allocated clients. You may want to create an IP Allocated client so that it will always get the same IP address. The IP Allocated clients are still configured as DHCP clients at the client end, but will always be served the same IP address by the device DHCP server.

To create an IP Allocated client select the Allocate button next to the client. The IP Allocation Entry section appears. Choose a Fixed address for the client and click "Save".

To change an IP Allocated client back to a normal DHCP client select it and click "Allocate". Then in the IP Allocation Entry section select "Address from DHCP pool" and click "Save".

Sometimes the lease and the LAN Host Discovery table will not change immediately. You may have to renew the lease or request service at the client for the change to complete.



NOTE:

IP Allocation functions require you to enter your NVG595 Gateway's access code. Information on the device code is provided in ["Device Access Code" on page 22](#)

The IP Allocation page lets you set aside or assign IP addresses to client devices on your network. With IP allocation, you can configure known devices to either use DHCP for dynamic IP address assignment, or set aside a specific IP address for a client device. When IP allocation is enabled for a client, that device is assigned a pre-determined IP address by the DHCP server of the NVG595. IP allocation lets you set up client devices as common DHCP systems, but ensures that they always receive the same IP address from the gateway.

The IP Allocation table shows a list of all identified and active client devices the NVG595 is serving.

To change the allocation method used by a client;

1. Locate the client in the IP Allocation table. The client may be identified by the *Name* value (in the *IPv4 Address/Name* column) or the device MAC address.
2. Click the [Allocate](#) button associated with the client entry.

The IP Allocation window for the client opens.

The screenshot shows the 'IP Allocation' window. At the top, there is a table with the following data:

IPv4 Address / Name	MAC Address	Status	Allocation	Action
192.168.1.64 / E51311-04	00:1e:ec:16:eb:f6	on	DHCP Allocation	<input type="button" value="Allocate"/>

Below the table is the 'IP Allocation Entry' section. It contains the following fields:

- IPv4 Address / Name: 192.168.1.64/E51311-04
- MAC Address: 00:1e:ec:16:eb:f6
- Current Allocation: DHCP Allocation
- New Allocation: A dropdown menu with the following options:
 - Private fixed:192.168.1.245
 - Private fixed:192.168.1.246
 - Private fixed:192.168.1.247
 - Private fixed:192.168.1.248
 - Private fixed:192.168.1.249
 - Private fixed:192.168.1.250
 - Private fixed:192.168.1.251
 - Private fixed:192.168.1.252

At the bottom of the window are 'Save' and 'Cancel' buttons.

3. Scroll through the New Allocation values and select the address or method to use for the client's DHCP assignment:
 - ◆ Click "Address from DHCP Pool" to set the client to accept any valid DHCP address available (standard operation).
 - ◆ Click any of the private fixed IP addresses (192.168.7.64 to 192.168.7.253) shown in the list to allocate that IP address to the selected client.
4. Click the Save button to save the IP allocation settings. A red "Changes saved" message opens at the top of the IP Allocation page.

Voice

If you click the [Voice](#) link, the **Voice Status** page opens.

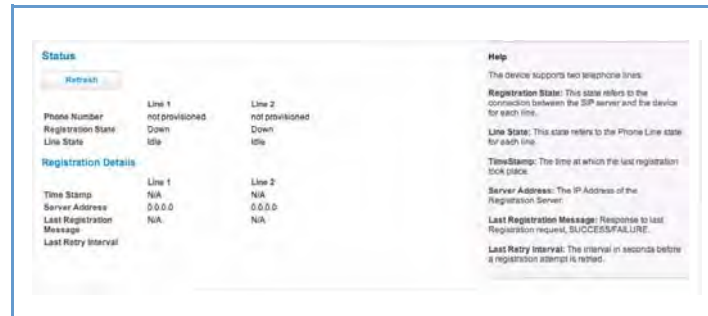

Voice-over-IP (VoIP) refers to the ability to make voice telephone calls over the Internet. This differs from traditional phone calls that use the Public Switched Telephone Network (PSTN). VoIP calls use an Internet protocol, Session Initiation Protocol (SIP), to transmit sound over a network or the Internet in the form of data packets.

- ◆ The Voice page displays information about your VoIP phone lines, if configured. Your Gateway supports two phones, **Line 1** and **Line 2**.
- ◆ If either one or both are registered with a SIP server by your service provider or not registered, the Voice page will display their **Registration Details**.

The links at the top of the Voice page access a series of pages to allow you to configure and monitor features of your device. The following sections give brief descriptions of these pages.

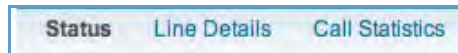

- ◆ ["Line Details" on page 53](#)
- ◆ ["Call Statistics" on page 54](#)

Link: Line Details

When you click the [Line Details](#) link, the **Line Details** page opens.

The screenshot shows the AT&T web interface for Line Details. The top navigation bar includes 'Device', 'Broadband', 'Local Network', 'Voice', 'Firewall', and 'Diagnostics'. The 'Voice' section is active, and the 'Line Details' link is selected. A 'Refresh' button is visible. A warning message states: 'Warning: Deregistering a line will disconnect any calls in progress and both incoming and outgoing voice service will be temporarily unavailable.' Below this is a table with two columns: 'Line 1' and 'Line 2'. The table contains the following data:

	Line 1	Line 2
Phone Number	4000	4001
Status	Registered	Registered
	Ring Line 1	Ring Line 2
	Deregister Line 1	Deregister Line 2

To the right of the table is a 'Help' section with the following text: 'This page allows you to display phone numbers being used by phones attached to this device, the status of these phone lines, and ring the phones attached to each line. Warning: If you deregister the phone line, any calls in progress will be disconnected.'

- ◆ If your service provider has enabled your VoIP phone lines, you can register them by clicking the [Register Line 1](#) or [Register Line 2](#) button(s).
- ◆ To test if the lines are enabled, click the [Ring Line 1](#) or [Ring Line 2](#) button(s). If enabled and registered, the respective phone will ring for 30 seconds.
- ◆ To update the display, click the [Refresh](#) button.

[Link: Call Statistics](#)

When you click [Call Statistics](#), the **Call Statistics** page opens.

Line 1	Last Call		Cumulative	
	Incoming	Outgoing	Incoming	Outgoing
RTP Packet Loss	0	0	0	0
RTP Packet Loss percentage	0.00%	0.00%	0.00%	0.00%
Total RTCP Packets	0	0	0	0
Average Inter Arrival Jitter (In ms)	0	0	N/A	N/A
Max Inter Arrival Jitter (In ms)	0	0	0	0
Sum of Inter Arrival Jitter (In ms)	0	0	0	0
Sum of Inter Arrival Jitter Squared (In ms)	0	0	0	0
Sum of Franc Loss	0	0	0	0
Sum of Franc Loss Squared	0	0	0	0
Max One Way Delay (In ms)	0	N/A	0	N/A
Sum of One Way Delay (In ms)	0	N/A	0	N/A
Sum of One Way Delay Squared	0	N/A	0	N/A
Avg Round Trip Time (In ms)	0	N/A	N/A	N/A
Max Round Trip Time (In ms)	0	N/A	0	N/A
Sum of Round Trip Time (In ms)	0	N/A	0	N/A
Sum of Round Trip Time Squared	0	N/A	0	N/A

Line 2	Last Call		Cumulative	
	Incoming	Outgoing	Incoming	Outgoing
RTP Packet Loss	0	0	0	0
RTP Packet Loss percentage	0.00%	0.00%	0.00%	0.00%
Total RTCP Packets	0	0	0	0
Average Inter Arrival Jitter (In ms)	0	0	N/A	N/A

For **Line 1** and **Line 2**; the two available phone lines, the Call Statistics page displays the following information:

Call Statistics - Line 1 and Line 2

Last Call/Cumulative – Incoming/Outgoing

RTP Packet Loss	Real-time Transport Protocol packets dropped
RTP Packet Loss percentage	Percent of Real-time Transport Protocol packets dropped
Total RTCP Packets	Total Real-time Transport Control Protocol packets
Average Inter Arrival Jitter	This is calculated continuously in milliseconds as each data packet is received and averaged.
Max Inter Arrival Jitter	This is the maximum value in milliseconds recorded as each data packet is received.
Sum of Inter Arrival Jitter	This is calculated continuously in milliseconds as each data packet is received and totalled.
Sum of Inter Arrival Jitter Squared	This is calculated continuously in milliseconds as each data packet is received and the total is squared.
Sum of Franc Loss	Fraction Lost: The fraction of RTP data packets lost since the previous SR or RR packet was sent. This fraction is defined to be the number of packets lost divided by the number of packets expected. This will be calculated on every RTCP SR packet. Sum of the fraction lost is calculated with all the RTCP packets.
Sum of Franc Loss Squared	Fraction lost is squared with every RTCP SR or RR packet. Sum of all this will give the Sum of Franc Loss Squared.
Max One Way Delay	One Way Delay will be calculated in milliseconds on every RTCP SR or RR packet. This value is $(\text{sys}time - \text{lsr} - r) / 2$ lsr means last SR timestamp r means delay since last SR.
Sum of One Way Delay	The sum of all the one way delays calculated in milliseconds on every RTCP packet is displayed as Sum of One Way Delay.
Sum of One Way Delay Squared	One Way Delay is squared with every RTCP SR or RR packet. Sum of all this will give the Sum of One Way Delay Squared.
Avg Round Trip Time	Average time in milliseconds from this local source to destination address and back again for all logged calls
Max Round Trip Time	Maximum amount of time in milliseconds from this local source to destination address and back again for all logged calls
Sum of Round Trip Time	Sum of time in milliseconds from this local source to destination address and back again for all logged calls
Sum of Round Trip Time Squared	Sum squared of time from this local source to destination address and back again for all logged calls

Call Summary				
	Line 1		Line 2	
	Current Call	Last Completed Call	Current Call	Last Completed Call
Call Timestamp	N/A	0	N/A	0
Type	N/A	N/A	N/A	N/A
Duration (in secs)	N/A	0	N/A	0
Codec in Use	N/A	N/A	N/A	N/A
Far-End Host Information	0.0.0.0	0.0.0.0	0.0.0.0	0.0.0.0
Far-End Caller Information	N/A	N/A	N/A	N/A

Cumulative Since Last Reset		
	Line 1	Line 2
Last Reset Timestamp	N/A	N/A
Number of Calls		
Duration (in secs)	0	0
Number of Incoming Calls Failed	0	0
Number of Outgoing Calls Failed	0	0

For **Line 1** and **Line 2**;, the two available phone lines, the Call Summary section displays the following information:

Call Summary - Line 1 and Line 2

Current Call/Last Completed Call	
Call Timestamp	Date and Time of the current call
Type	May be Incoming or Outgoing
Duration	Length of time in seconds of call connection
Codec in Use	Audio codec used for decoding the call packet traffic.
Far-End Host Information	SIP server IP information: IP address and port number
Far-End Caller Information	Caller ID information, if available
Cumulative Since Last Reset	
Last Reset Timestamp	Date and Time of the last call
Number of Calls	Total number of calls for each VoIP line
Duration	Time in seconds since the last call
Number of Incoming Calls Failed	Number of Incoming calls that fail to connect
Number of Outgoing Calls Failed	Number of Outgoing calls that fail to connect

The following table is the simplified version of VOIP line/hook/etc. states during different conditions.

VOIP Line 1/2	Hook state	WAN IP	Reg-state	FXS Voltage	Tone	LED
Disable	On/Off-hook	UP	Idle	OFF	N/A	off
Enabled	On-hook	UP	Registered	ON	N/A	Solid
Enabled	Off-hook	UP	Registered	ON	DIAL TONE	Blink
Enabled	On/off hook	UP	Failure	OFF	N/A	off
Enabled	On/off hook	DOWN	Idle	OFF	N/A	off

The following table provides the state changes during the boot-up procedure.

VOIP Line 1/2	WAN Status	Hook State	Reg-state	FXS Voltage	Tone	LED
Disable	Down	Off-hook	Idle	On-to-off	off	off
Enabled	Down	On/Off-hook	Idle	ON	Congestion	off
	Up	Off-hook	Registered	ON	Congestion. Dial Tone played after the hook state is changed.	ON
Enabled						

Firewall

When you click the [Firewall](#) tab, the **Firewall Status** page opens. The Firewall page displays the status of your system firewall elements.

All computer operating systems are vulnerable to attack from outside sources, typically at the operating system or Internet Protocol (IP) layers. Stateful Inspection firewalls intercept and analyze incoming data packets to determine whether they should be admitted to your private LAN, based on multiple criteria, or blocked. Stateful inspection improves security by tracking data packets over a period of time, examining incoming and outgoing packets. Outgoing packets that request specific types of incoming packets are tracked; only those incoming packets constituting a proper response are allowed through the firewall.

Stateful inspection is a security feature that prevents unsolicited inbound access when NAT is disabled. You can configure UDP and TCP “no-activity” periods that will also apply to NAT time-outs if stateful inspection is enabled on the interface. Stateful Inspection parameters are active on a WAN interface only if enabled on your system. Stateful inspection can be enabled on a WAN interface whether NAT is enabled or not.

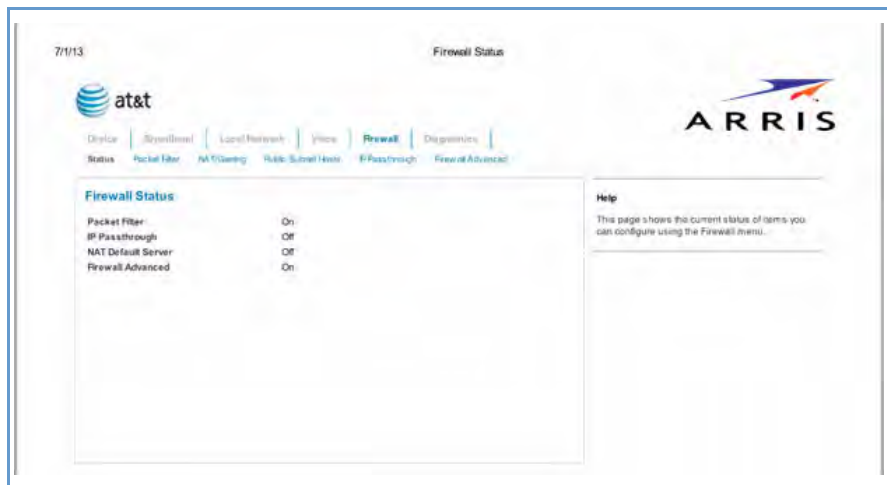

The center section displays the following:

Packet	May be On or Off
IP Passthrough	May be On or Off
NAT Default Server	May be On or Off
Firewall Advanced	May be On or Off

The links at the top of the Firewall page access a series of pages to allow you to configure security features of your device. The following sections give brief descriptions of these pages.

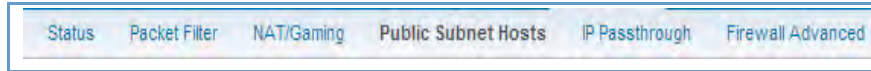

- ◆ [“Packet Filter” on page 60](#)
- ◆ [“NAT/Gaming” on page 69](#)
- ◆ [“Public Subnet Hosts” on page 74](#)
- ◆ [“IP Passthrough” on page 75](#)
- ◆ [“Firewall Advanced” on page 78](#)

Link: Packet Filter

When you click the [Packet](#) Filter link the **Packet Filter** screen opens.

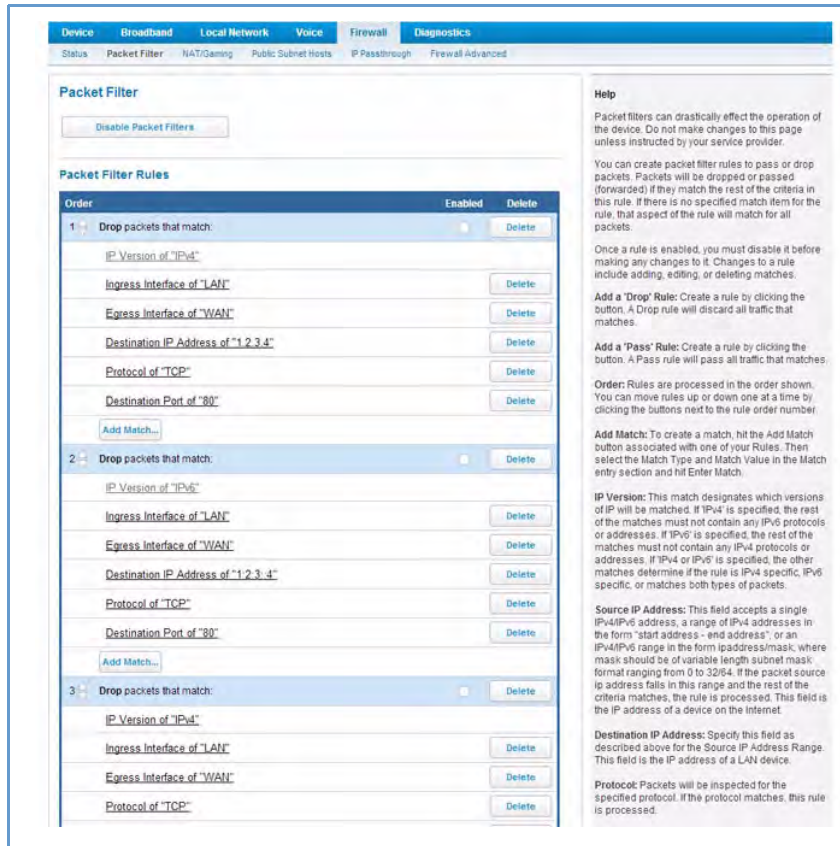

Security should be a high priority for anyone administering a network connected to the Internet. Using packet filters to control network communications can greatly improve your network's security. The Packet Filter engine allows creation of a maximum of eight Filtersets. Each Filterset can have up to eight rules configured.



WARNING:

Before attempting to configure filters and filtersets, please read and understand this entire section thoroughly. The ARRIS Gateway incorporating NAT has advanced security features built in. Improperly adding filters and filtersets increases the possibility of loss of communication with the Gateway and the Internet. Never attempt to configure filters unless you are local to the Gateway.

Although using filtersets can enhance network security, there are disadvantages:

- Filters are complex. Combining them in filtersets introduces subtle interactions, increasing the likelihood of implementation errors.
- Enabling a large number of filters can have a negative impact on performance. Processing of packets will take longer if they have to go through many checkpoints in addition to NAT.
- Too much reliance on packet filters can cause too little reliance on other security methods. Filtersets are not a substitute for password protection, effective safeguarding of passwords, and general awareness of how your network may be vulnerable.

ARRIS's packet filters are designed to provide security for the Internet connections made to and from your network. You can customize the Gateway's filtersets for a variety of packet filtering applications. Typically, you use

filters to selectively admit or refuse TCP/IP connections from certain remote networks and specific hosts. You will also use filters to screen particular types of connections. This is commonly called firewalling your network.

Before creating filtersets, you should read the next few sections to learn more about how these powerful security tools work.

Parts of a filter

A filter consists of criteria based on packet attributes. A typical filter can match a packet on any one of the following attributes:

- ◆ The source IP address (where the packet was sent from)
- ◆ The destination IP address (where the packet is going)
- ◆ The type of higher-layer Internet protocol the packet is carrying, such as TCP or UDP

Other filter attributes

There are three other attributes to each filter:

- ◆ The filter's order (i.e., priority) in the filterset
- ◆ Whether the filter is currently active
- ◆ Whether the filter is set to forward packets or to block (discard) packets

Design guidelines

Careful thought must go into designing a new filterset. You should consider the following guidelines:

- ◆ Be sure the filterset's overall purpose is clear from the beginning. A vague purpose can lead to a faulty set, and that can actually make your network less secure.
- ◆ Be sure each individual filter's purpose is clear.
- ◆ Determine how filter priority will affect the set's actions. Test the set (on paper) by determining how the filters would respond to a number of different hypothetical packets.
- ◆ Consider the combined effect of the filters. If every filter in a set fails to match on a particular packet, the packet is:
 - Forwarded if all the filters are configured to discard (not forward)
 - Discarded if all the filters are configured to forward
 - Discarded if the set contains a combination of forward and discard filters

An approach to using filters

The ultimate goal of network security is to prevent unauthorized access to the network without compromising authorized access. Using filtersets is part of reaching that goal.

Each filterset you design will be based on one of the following approaches:

- ◆ That which is not expressly prohibited is permitted.
- ◆ That which is not expressly permitted is prohibited.

It is strongly recommended that you take the latter, and safer, approach to all of your filterset designs.

Working with Packet Filters

To work with filters, begin by accessing the **Packet Filter** page.

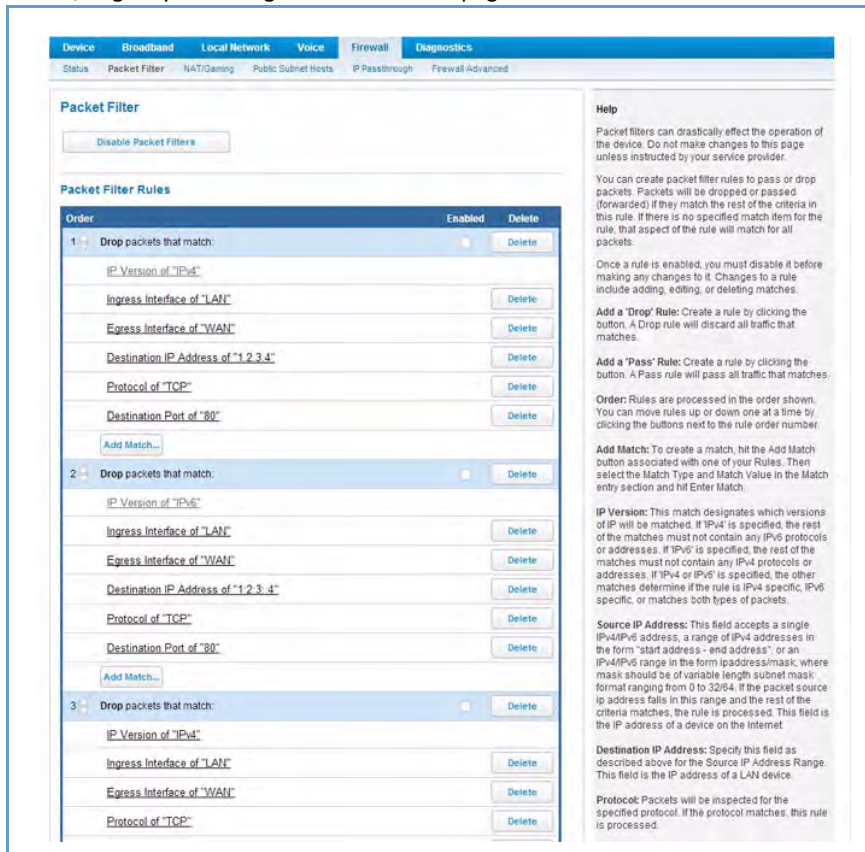

Packet Filter

◆ [Enable/Disable Packet Filters](#) – Click this button to globally turn your filters on or off.

Packet Filter Rules

Buttons: Click either [Add a 'Drop' Rule](#) or [Add a 'Pass' Rule](#) button.

◆ **Action:**

- **drop:** If you select **drop**, the specified packets will be blocked.
- **pass:** If you select **pass**, the specified packets will be forwarded.

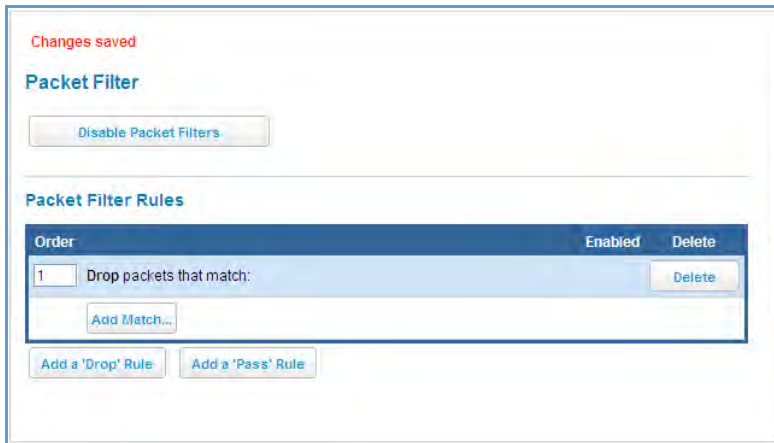

- ◆ Enter the **Source IP Address** or **Destination IP Address** this filter will match on.
As you create new Matches, the pull-down items change. There can only be one match from each Match Type for a given rule. Match Types like Source Port, Destination Port, and TCP Flags are only available if other matches (for example, Protocol =TCP) have previously been created.
- ◆ Select **Protocol**, if necessary, from the pull-down menu: **ICMP**, **TCP**, **UDP**, or **None** to specify any another IP transport protocol.
If you chose **by number**, enter the **Protocol by number** here.
If you chose **by name**, enter the **Protocol by name** here.
Enter the **Source Port** this filter will match on.
Enter the **Destination Port** this filter will match on.
If you selected **ICMP**, enter the **ICMP Type** here.



When you are finished configuring the filter, click the [Enter Match](#) button.

The filter is automatically saved.

Packet Filter Rules List

Your entries are displayed as a table.

Changes saved

Packet Filter

Disable Packet Filters

Packet Filter Rules

Order	Enabled	Delete
1		Delete
Drop packets that match:		
Source IP Address of "207.53.17.9"		
Add Match...		
2		Delete
Pass packets that match:		
Source IP Address of "207.53.17.0/24"		
Add Match...		

Update Order Add a 'Drop' Rule Add a 'Pass' Rule



NOTE:

Default Forwarding Filter

If you create one or more filters that have a matching action of forward, then action on a packet matching none of the filters is to block any traffic.

Therefore, if the behavior you want is to force the routing of a certain type of packet and pass all others through the normal routing mechanism, you must configure one filter to match the first type of packet and apply Force Routing. A subsequent filter is required to match and forward all other packets.

Management IP traffic

If the Force Routing filter is applied to source IP addresses, it may inadvertently block communication with the router itself. You can avoid this by preceding the Force Routing filter with a filter that matches the destination IP address of the Gateway itself.

Example:

Assume a configured Custom Service/Hosted Application for an internal web server whose Global Port Range is 8080-8080. Also assume that we want to allow only one external subnet access to this internal server, 207.53.17.0/24. And finally, assume that we want to disallow one IP address on that subnet, 207.53.17.9, from access to that same server (perhaps they were abusing the system in some way). The rules we need are:

Input Rules:

Rule Order	Action	Source IP	Destination IP	Protocol	Source Port	Destination Port
1	Drop	207.53.17.9	-	TCP		8080
2	Pass	207.53.17.0/24	-	TCP		8080
3	Drop	-	-	TCP		8080

Changes saved

Packet Filter

Disable Packet Filters

Packet Filter Rules

Order		Enabled	Delete
1	Drop packets that match:		Delete
	Source IP Address of "207.53.17.9"		Delete
	Add Match...		
2	Pass packets that match:		Delete
	Source IP Address of "207.53.17.0/24"		Delete
	Add Match...		

Update Order

Add a 'Drop' Rule

Add a 'Pass' Rule

Example 2

The following example uses the GUI to detail how to create a public subnet.

1. Select **Local Network -> Subnets & DHCP** from the Web Management GUI

2. Select **On** from the **Public Subnet Enable** drop down menu.
3. Enter all applicable public subnet IP address information and select **save** at the bottom of the view.
4. Navigate to **Firewall -> Packet Filter** to create a packet filter that will allow specific traffic to flow to a public LAN client

5. Scroll to the bottom of the screen and select **Add a Pass Rule**. This rule will allow traffic to flow through the public subnet based on the **match** criteria that will be set up next.
6. The new rule will be at the bottom of the Packet Rules list (as shown below).

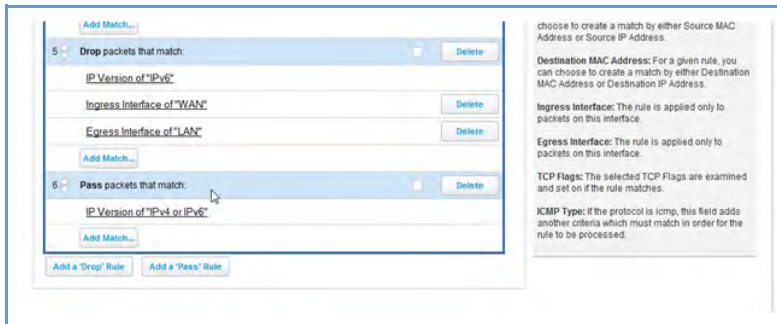

7. Select the **Add Match** button below the new rule created in step 5. This opens the **Match Entry** view.

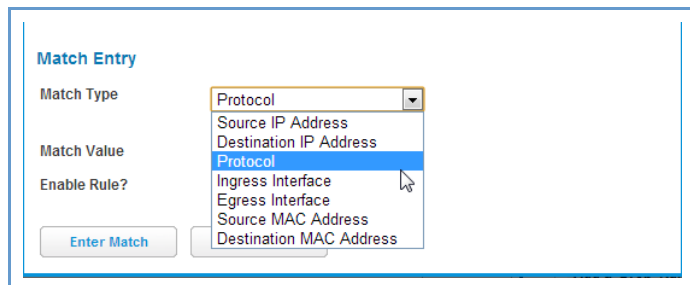

8. For this example, the filter will be made based on a TCP port. So select **Protocol** from the **Match Type** drop down menu, this automatically fills in TCP in the **Match Value** field. At this point do not enable the rule until all criteria has been entered.
9. Click **Enter Match**. This will return the GUI to the Packet Rules list.
10. Select **Add Match** below the rule created earlier.
11. Select **Destination Port** from the **Match Type** drop down menu and enter 21 (this value corresponds to FTP) in the **Match Value** entry box.
12. Click **Enter Match**.
13. Select **Add Match** below the same rule created earlier.

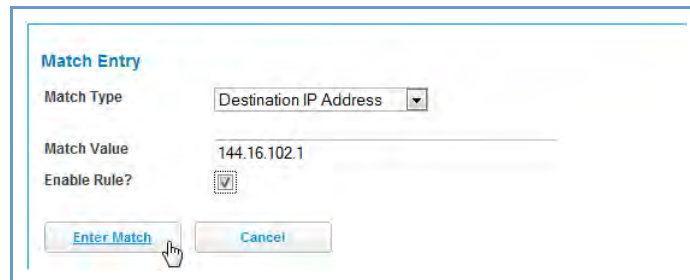

14. Select **Destination IP Address** from the **Match Type** drop down menu and enter the IP address entered in Step 3 of this procedure.
15. Select the check box by **Enable Rule** and click **Enter Match**. The GUI is returned to the Packet Rules list and the rule is active and grayed out and cannot be edited without first disabling the rule.

The screenshot displays a configuration window for firewall rules. It contains two rule entries:

- Rule 5:** "Drop packets that match." This rule is currently disabled (indicated by a greyed-out checkbox). It has three match criteria:
 - IP Version of "IPv6"
 - Ingress Interface of "WAN"
 - Egress Interface of "LAN"There is an "Add Match..." button below these criteria and a "Delete" button to the right.
- Rule 6:** "Pass packets that match." This rule is enabled (indicated by a checked checkbox). It has four match criteria:
 - IP Version of "IPv4"
 - Protocol of "TCP"
 - Destination Port of "21"
 - Destination IP Address of "144.16.102.1"There is an "Add Match..." button below these criteria and a "Delete" button to the right.

At the bottom of the rule list are two buttons: "Add a 'Drop' Rule" and "Add a 'Pass' Rule".

On the right side of the window, there is a help section with the following text:

- Destination MAC Address:** For a given rule, you can choose to create a match by either Destination MAC Address or Destination IP Address.
- Ingress Interface:** The rule is applied only to packets on this interface.
- Egress Interface:** The rule is applied only to packets on this interface.
- TCP Flags:** The selected TCP Flags are examined and set on if the rule matches.
- ICMP Type:** If the protocol is icmp, this field adds another criteria which must match in order for the rule to be processed.

Link: NAT/Gaming

When you click the [NAT/Gaming](#) link, the **NAT/Gaming** page opens.

NAT/Gaming

Hosted Applications

No Application Hosting entries have been defined

Application Hosting Entry

Service: AIM Talk

Needed by Device: 192.168.1.65

Manage Custom Services

NAT/Gaming allows you to host internet applications when NAT is enabled. You can host different games and software on different PCs.

From the **Service** pull-down menu, you can select any of a large number of predefined games and software. (See [“List of Supported Games and Software” on page 72.](#))

In addition to choosing from these predefined services you can also select a user defined custom service. (See [“Custom Services” on page 71.](#))

For each supported game or service, you can view the protocols and port ranges used by the game or service by clicking the [Service Details](#) button. For example:

Service Details

Service Name	AIM Talk
Protocol	TCP/UDP
Global Port Range	3000-3000
Protocol	TCP/UDP
Global Port Range	5190-5190

Select a hosting device from the **Needed by Device** pull-down menu.

1. Once you choose a software service or game, click [Add](#).
2. Select a PC to host the software from the Select Host Device pull-down menu and click [Save](#).

NAT/Gaming

Hosted Applications

No Rules entries have been defined

Application Hosting Entry

Service: Age of Empires: The Rise of Rome, v.1.0 [Details](#)

Needed by Device: precision-m65

[Add](#) [Save](#)

Custom Services

[Add/Edit Services](#)

Each time you enable a software service or game your entry will be added to the list of **Service** names displayed on the NAT Configuration page.

Changes saved

NAT/Gaming

Hosted Applications

Service	Ports	Device	Delete
AIM Talk	TCP/UDP: 3000,5190	E51311-04	Delete

Application Hosting Entry

Service: Apache [Service Details](#)

Needed by Device: E51311-04

[Add](#)

Manage Custom Services

[Custom Services](#)

To remove a game or software from the hosted list, choose the game or software you want to remove and click the [Remove](#) button.

Custom Services

To configure a Custom Service, click the [Add/Edit Services](#) button. The **Custom Services** page opens.



Custom Services

Service List

No Custom Service entries have been defined

Service Entry

Service Name

Global Port Range -

Base Host Port

Protocol

[Add](#)

[Return to NAT/Gaming](#)

Enter the following information:

- ◆ **Service Name:** A unique identifier for the Custom Service.
- ◆ **Global Port Range:** Range of ports on which incoming traffic will be received.
- ◆ **Base Host Port:** The port number at the start of the port range your Gateway should use when forwarding traffic of the specified type(s) to the internal IP address.
- ◆ **Protocol:** Protocol type of Internet traffic, TCP or UDP.

Once you define a Custom Service it becomes available in the **Application Hosting Entry Service** menu as one of the services to select.

Click the [Add](#) button.

Each time you enable a custom service your entry will be added to the list of **Service** names displayed on the Custom Services page.

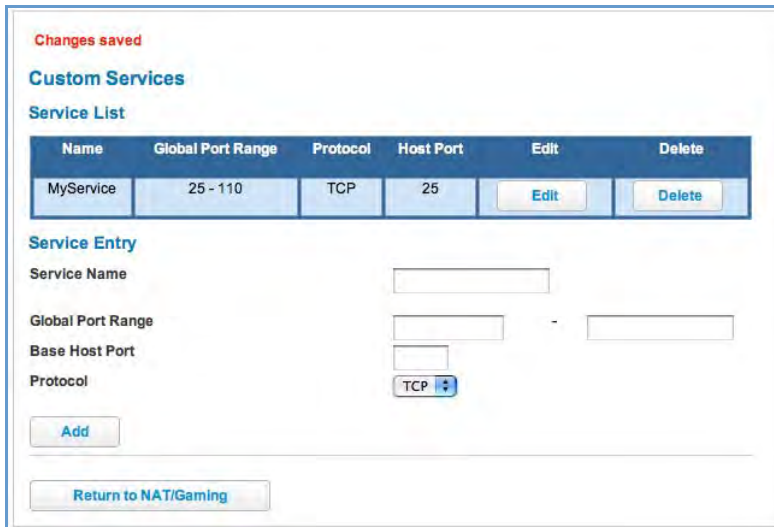

Changes saved

Custom Services

Service List

Name	Global Port Range	Protocol	Host Port	Edit	Delete
MyService	25 - 110	TCP	25	Edit	Delete

Service Entry

Service Name

Global Port Range -

Base Host Port

Protocol

[Add](#)

[Return to NAT/Gaming](#)

Changes are saved immediately.

To remove this Service, click the [Delete](#) button.

To edit this Service, click the [Edit](#) button.



NOTE:

You cannot edit a Custom Service if the Service is active; it must be inactive before it can be edited.

List of Supported Games and Software

AIM Talk	Act of War - Direct Action	Age of Empires II
Age of Empires, v.1.0	Age of Empires: The Rise of Rome, v.1.0	Age of Mythology
Age of Wonders	America's Army	Apache
Asheron's Call	Azureus	Baldur's Gate I and II
Battlefield 1942	Battlefield Communicator	Battlefield Vietnam
BitTornado	BitTorrent	Black and White
Blazing Angels Online	Brothers in Arms - Earned in Blood	Brothers in Arms Online
Buddy Phone	CART Precision Racing, v 1.0	Calista IP Phone
Call of Duty	Citrix Metaframe/ICA Client	Close Combat III: The Russian Front, v 1.0
Close Combat for Windows 1.0	Close Combat: A Bridge Too Far, v 2.0	Combat Flight Sim 2: WWII Pacific Thr, v 1.0
Combat Flight Sim: WWII Europe Series, v 1.0	Counter Strike	DNS Server
Dark Reign	Delta Force (Client and Server)	Delta Force 2
Delta Force Black Hawk Down	Diablo II Server	Dialpad
DirecTV STB 1	DirecTV STB 2	DirecTV STB 3
Doom 3	Dues Ex	Dune 2000
Empire Earth	Empire Earth 2	F-16, Mig 29
F-22, Lightning 3	FTP	Far Cry
Fighter Ace II	GNUtella	Grand Theft Auto 2 Multiplayer
H.323 compliant (Netmeeting, CUSeeME)	HTTP	HTTPS
Half Life	Half Life 2 Steam	Half Life 2 Steam Server
Half Life Steam	Half Life Steam Server	Halo
Hellbender for Windows, v 1.0	Heretic II	Hexen II
Hotline Server	ICQ 2001b	ICQ Old

IMAP Client	IMAP Client v.3	IPSec IKE
Internet Phone	Jedi Knight II: Jedi Outcast	Kali
KazaA	Lime Wire	Links LS 2000
Lord of the Rings Online	MSN Game Zone	MSN Game Zone DX
MSN Messenger	Mech Warrior 3	MechWarrior 4: Vengeance
Medal of Honor Allied Assault	Microsoft Flight Simulator 2000	Microsoft Flight Simulator 98
Microsoft Golf 1998 Edition, v 1.0	Microsoft Golf 1999 Edition	Microsoft Golf 2001 Edition
Midtown Madness, v 1.0	Monster Truck Madness 2, v 2.0	Monster Truck Madness, v 1.0
Motocross Madness 2, v 2.0	Motocross Madness, v 1.0	NNTP
Need for Speed 3, Hot Pursuit	Need for Speed, Porsche	Net2Phone
Operation FlashPoint	Outlaws	POP-3
PPTP	PlayStation Network	Quake 2
Quake 3	Quake 4	Rainbow Six
RealAudio	Return to Castle Wolfenstein	Roger Wilco
Rogue Spear	SMTP	SNMP
SSH server	ShoutCast Server	SlingBox
Soldier of Fortune	StarCraft	StarLancer, v 1.0
Starfleet Command	TFTP	TeamSpeak
Telnet	Tiberian Sun: Command and Conquer	Timbuktu
Total Annihilation	Ultima Online	Unreal Tournament Server
Urban Assault, v 1.0	VNC, Virtual Network Computing	Warlords Battlecry
Warrock	Westwood Online, Command and Conquer	Win2000 Terminal Server
Wolfenstein Enemy Territory	World of Warcraft	X-Lite
XBox 360 Media Center	XBox Live 360	Yahoo Messenger Chat
Yahoo Messenger Phone	ZNES	eDonkey
eMule	eMule Plus	iTunes
mIRC Auth-IdentD	mIRC Chat	mIRC DCC - IRC DCC
pcAnywhere (incoming)		

Link: Public Subnet Hosts

Select **Firewall** -> **Public Subnet Hosts** to open this view. This view provides the ability to create public subnet hosts. In order to create a public subnet host it must be enabled (turned on) in the **Public Subnet** section of ["Subnets & DHCP" on page 48](#). To create a Public Subnet, click on the [Public Subnet](#) hyperlink.

The screenshot displays the AT&T ARRIS web interface. At the top left is the AT&T logo, and at the top right is the ARRIS logo. Below the logos is a navigation bar with tabs for Device, Broadband, Local Network, Voice, Firewall, and Diagnostics. Under the Firewall tab, there are sub-tabs for Status, Packet Filter, NAT/Gaming, Public Subnet Hosts, IP Passthrough, and Firewall Advanced. The main content area is titled "Public Subnet Hosts" and contains the following text: "You must configure a [Public Subnet](#) and "Allow Inbound Traffic" must be turned Off to use Public Subnet Hosts." To the right of this text is a "Help" section with the following content: "When using Public Subnets, you can create pinholes in the firewall of the Public LAN Subnet by creating Public Subnet Host Rules. The Public Subnet Hosts feature must be enabled to take effect. If the feature is enabled, but no rules defined, the feature has no effect. Public Subnet Hosts cannot be configured unless a Public Subnet is configured on the device and Allow Inbound Traffic is Off. The Public Subnet Rule List displays pinhole rules previously entered. The Public Subnet Rule Entry area is where new rules are added or edited. **IP Address:** An IPv4 Address on the Public Subnet can be specified in the form xxx.xxx.xxx.xxx. This entry is required. **Protocol:** You can optionally specify the protocol of the traffic to accept. **Port Range:** When Protocol is UDP or TCP, you can optionally specify a port or range of ports on which traffic will be accepted."

Link: IP Passthrough

When you click the [IP Passthrough](#) link, the **IP Passthrough** page opens.



The screenshot shows the 'IP Passthrough' configuration page. The 'Allocation Mode' dropdown is set to 'Off'. The 'Default Server Internal Address' field is empty. The 'Passthrough Mode' dropdown is set to 'DHCP5-dynamic'. The 'Passthrough Fixed MAC Address' field is empty. The 'Passthrough DHCP Lease' is set to 0 Days, 0 Hours, 10 Minutes, and 0 Seconds. There are 'Save' and 'Cancel' buttons at the bottom.

IP Passthrough

The IP Passthrough feature allows a single PC on the LAN to have the ARRIS Gateway's public address assigned to it. It also provides PAT (NAPT) via the same public IP address for all other hosts on the private LAN subnet.

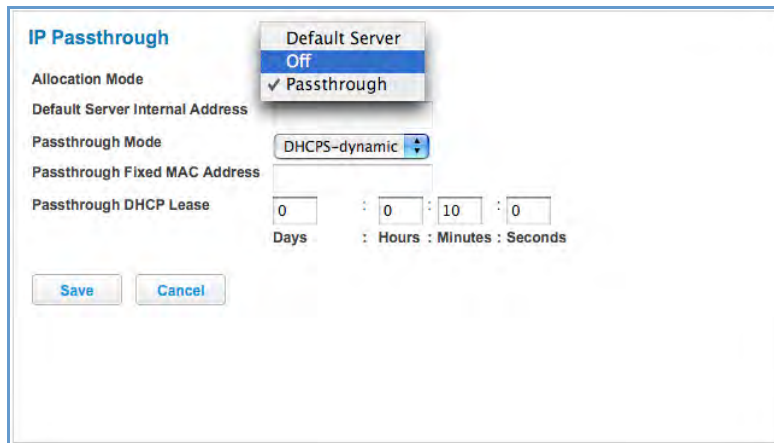

The screenshot shows the 'IP Passthrough' configuration page with the 'Allocation Mode' dropdown menu open. The menu options are 'Off' and 'Passthrough', with 'Passthrough' selected and marked with a checkmark. The other settings are the same as in the previous screenshot: 'Default Server Internal Address' is empty, 'Passthrough Mode' is 'DHCP5-dynamic', 'Passthrough Fixed MAC Address' is empty, and 'Passthrough DHCP Lease' is 0 Days, 0 Hours, 10 Minutes, and 0 Seconds. There are 'Save' and 'Cancel' buttons at the bottom.

Using IP Passthrough, the public WAN IP is used to provide IP address translation for private LAN computers. The public WAN IP is assigned and reused on a LAN computer.

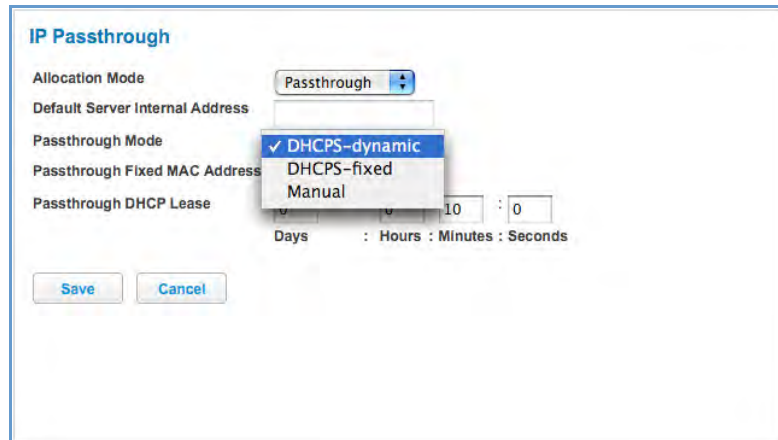

DHCP address serving can automatically serve the WAN IP address to a LAN computer.

When **DHCP** is used for addressing the designated passthrough PC, the acquired or configured WAN address is passed to DHCP, which will dynamically configure a single-servable-address subnet, and reserve the address for the configured PC's MAC address. This dynamic subnet configuration is based on the local and remote WAN address and subnet mask.

- ◆ The two **DHCP** modes assign the WAN IP information needed to the client automatically.
 - You can select the MAC address of the PC you want to be the IP Passthrough client with **fixed** mode, or,
 - with “first-come-first-served” – **dynamic** – the first client to renew its address will be assigned the WAN IP.
- ◆ **Manual** mode is like statically configuring your PC. With Manual mode, you configure the **TCP/IP Properties** of the LAN client PC you want to be the IP Passthrough client. You then manually enter the WAN IP address, Gateway Address, etc. that matches the WAN IP address information of your ARRIS Gateway. This mode works the same as the DHCP modes. Unsolicited WAN traffic will get passed to this client. The client is still able to access the ARRIS Gateway and other LAN clients on the 192.168.1.x network, etc.
- ◆ The **Passthrough DHCP Lease** – By default, the passthrough host's DHCP leases will be shortened to two minutes. This allows for timely updates of the host's IP address, which will be a private IP address before the WAN connection is established. After the WAN connection is established and has an address, the passthrough host can renew its DHCP address binding to acquire the WAN IP address. You may alter this setting.
- ◆ Click [Save](#). Changes take effect upon restart.

A restriction

Since both the Gateway and the passthrough host will use the same IP address, new sessions that conflict with existing sessions will be rejected by the Gateway. For example, suppose you are a teleworker using an IPSec tunnel from the Router and from the passthrough host. Both tunnels go to the same remote endpoint, such as the VPN access concentrator at your employer's office. In this case, the first one to start the IPSec traffic will be allowed; the second one – since, from the WAN, it's indistinguishable – will fail.

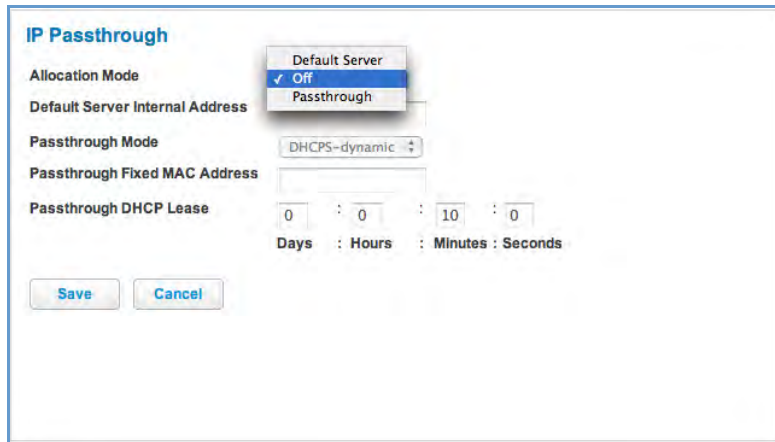

NAT Default Server

This feature allows you to:

- ◆ Direct your Gateway to forward all externally initiated IP traffic (TCP and UDP protocols only) to a default host on the LAN, specified by your entry in the **Internal Address** field.
- ◆ Enable it for certain situations:
 - Where you cannot anticipate what port number or packet protocol an in-bound application might use. For example, some network games select arbitrary port numbers when a connection is opened.
 - When you want all unsolicited traffic to go to a specific LAN host.

This feature allows you to direct unsolicited or non-specific traffic to a designated LAN station. With NAT “On” in the Gateway, these packets normally would be discarded.

For instance, this could be application traffic where you don’t know (in advance) the port or protocol that will be used. Some game applications fit this profile.

- ◆ Click [Save](#). Changes take effect immediately.

[Link: Firewall Advanced](#)

When you click the [Firewall Advanced](#) link the **Firewall Advanced** screen opens.

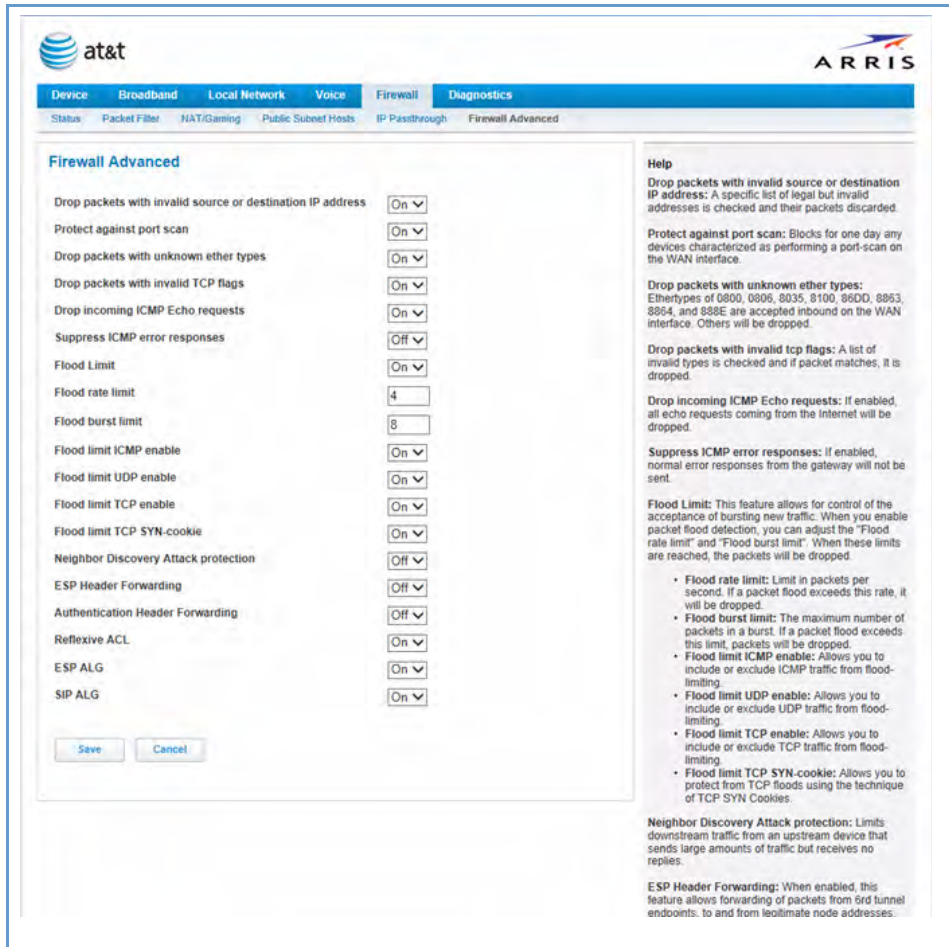

All computer operating systems are vulnerable to attack from outside sources, typically at the operating system or Internet Protocol (IP) layers. Stateful Inspection firewalls intercept and analyze incoming data packets to determine whether they should be admitted to your private LAN, based on multiple criteria, or blocked. Stateful inspection improves security by tracking data packets over a period of time, examining incoming and outgoing packets. Outgoing packets that request specific types of incoming packets are tracked; only those incoming packets constituting a proper response are allowed through the firewall.

Stateful inspection is a security feature that prevents unsolicited inbound access when NAT is disabled. You can configure UDP and TCP “no-activity” periods that will also apply to NAT time-outs if stateful inspection is enabled on the interface. Stateful Inspection parameters are active on a WAN interface only if enabled on your Gateway. Stateful inspection can be enabled on a WAN interface whether NAT is enabled or not.

DoS Protection – Denial-Of-Service attacks are common on the Internet, and can render an individual PC or a whole network practically unusable by consuming all its resources. Your Gateway includes default settings to

block the most common types of DoS attacks. For special requirements or circumstances, a variety of additional blocking characteristics is offered. See the following table.

Menu item	Function
Drop packets with invalid source or destination IP address	Whether packets with invalid source or destination IP address(es) are to be dropped
Protect against port scan	Whether to detect and drop port scans.
Drop packets with unknown ether types	Whether packets with unknown ether types are to be dropped
Drop packets with invalid TCP flags	Whether packets with invalid TCP flag settings (NULL, FIN, Xmas, etc.) should be dropped
Drop incoming ICMP Echo requests	Whether all ICMP echo requests are to be dropped; On or Off .
Flood Limit	Whether packet flooding should be detected and offending packets be dropped; On or Off .
Flood rate limit	Specifies the number limit of packets per second before dropping the remainder.
Flood burst limit	Specifies the number limit of packets in a single burst before dropping the remainder.
Flood limit ICMP enable	Whether ICMP traffic packet flooding should be detected and offending packets be dropped; On or Off .
Flood limit UDP enable	Whether UDP traffic packet flooding should be detected and offending packets be dropped; On or Off .
Flood limit UDP Pass multicast	Allows exclusion of UDP multicast traffic. On by default.
Flood limit TCP enable	Allows exclusion of TCP traffic. Off by default.
Flood limit TCP SYN-cookie	Allows TCP SYN cookies flooding to be excluded.
Neighbor Discovery Attack protection	Prevents downstream traffic from an upstream device that sends excessive traffic but receives no replies; On or Off .
ESP Header Forwarding	Allows the use of Encapsulating Security Payload (ESP) data payload encryption for IP Secure (IPsec) from qualifying endpoints; On or Off .
Authentication Header Forwarding	Accept and forward IPsec packets with Authentication Headers, which may be used by some IPsec implementations to validate packet sources ; On or Off .
Reflexive ACL	When IPv6 is enabled, Reflexive Access Control Lists can deny inbound IPv6 traffic unless this traffic results from returning outgoing packets (except as configured through firewall rules).
ESP ALG	This feature helps ESP (IPsec encryption), work properly when using NAT. Can sometimes cause problems for non-NATed hosts (such as devices on the Public LAN).
SIP ALG	This feature understands the SIP protocol used by the specific application and does a protocol-packet inspection of traffic through it. A NAT router with a built in SIP ALG can rewrite information within the SIP messages (SIP heads and SDP body) making signalling and audio traffic between the client behind NAT and the SIP endpoint possible.

If you make any changes here, click the [Save](#) button.

Diagnostics

When you click the [Diagnostics](#) tab, the **Troubleshoot** page opens.

The screenshot shows a web interface titled "Troubleshoot". Below the title is a message: "Running this test will help locate problems with your Internet Connection." Below this message is a table with four rows, each representing a diagnostic test. Each row has a text input field, a status indicator (a dash), and a "Details" button. Below the table is a "Run Full Diagnostics" button. Below that is a section titled "Test Internet Access" with instructions: "Enter an Internet Address in the 'Address' field and click on the button of the test to perform." This section includes an "Address" input field, a "Preferred protocol" section with radio buttons for "IPv4" (selected) and "IPv6", and three buttons: "Ping", "Traceroute", and "NSlookup". At the bottom is a "Progress Window" which is currently empty.

Test	Status	Action
Ethernet	-	Details
IP	-	Details
DNS	-	Details
6rd Continuity	-	Details

[Run Full Diagnostics](#)

Test Internet Access

Enter an Internet Address in the 'Address' field and click on the button of the test to perform.

Address

Preferred protocol IPv4 IPv6 [Ping](#) [Traceroute](#) [NSlookup](#)

Progress Window

This automated multi-layer test examines the functionality of the Router from the physical connections to the data traffic being sent by users through the Router.

You can run all the tests in order by clicking the [Run Full Diagnostics](#) button.

The device will automatically test a number of components to determine any problems. You can see detailed results of the tests by clicking the [Details](#) buttons for each item. The details presented depend on the configuration of your Router and your network type.

Here is an example of the Ethernet Details screen.

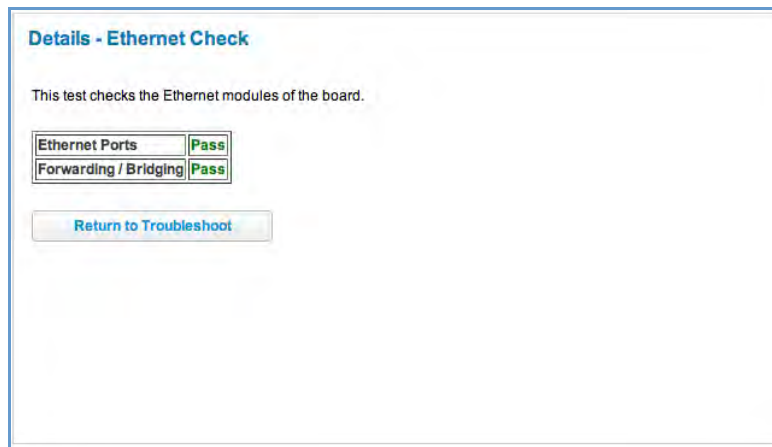

Test Internet Access

These tests send a PING from the modem to either the LAN or WAN to verify connectivity. A PING could be either an IP address (163.176.4.32) or Domain Name (www.mycompany.com). You enter a web address URL or an IP address in the respective field.

Click the [Ping](#), [Trace](#), or [NSLookup](#) button.

Results will be displayed in the **Progress Window** as they are generated.

- ◆ **Ping** - tests the “reachability” of a particular network destination by sending an ICMP echo request and waiting for a reply.
- ◆ **Traceroute** - displays the path to a destination by showing the number of hops and the router addresses of these hops.
- ◆ **NSLookup** - converts a domain name to its IP address and vice versa.

To use the Ping capability, type a destination address (domain name or IP address) in the text box and click the [Ping](#), [Trace](#), or [Lookup](#) button. The results are displayed in the **Progress Window**.

This sequence of tests takes approximately one minute to generate results. Please wait for the test to run to completion.

Each test generates one of the following result codes:

Result	Meaning
* PASS:	The test was successful.
* FAIL:	The test was unsuccessful.
* SKIPPED:	The test was skipped because a test on which it depended failed.
* PENDING:	The test timed out without producing a result. Try running the test again.
* WARNING:	The test was unsuccessful. The Service Provider equipment your Modem connects to may not support this test.

Below are some specific tests:

Action	If PING fails, possible causes are:
From the Check Connection page:	
Ping the internet default gateway IP address	Connection is down; Gateway's IP address or subnet mask are wrong; gateway router is down.
Ping an internet site by IP address	Site is down.
Ping an internet site by name	Servers are down; site is down.
From a LAN PC:	
Ping the Modem's LAN IP address	IP address and subnet mask of PC are not on the same scheme as the Modem; cabling or other connectivity issue.
Ping an internet site by IP address	PC's subnet mask may be incorrect, site is down.
Ping an internet site by name	DNS is not properly configured on the PC, site is down.

Link: Logs

When you click [Logs](#), the Logs page opens.

Logs

Clear Log Save to File... Select Log **System** Firewall VoIP

```
P0000-00-00T00:00:04 L6 sdb[318]: log buffer s
P0000-00-00T00:00:04 L7 sdb[318]: libmotopia:
P0000-00-00T00:00:04 L7 sdb[318]: starting process /sbin/klogd (pid 323)
P0000-00-00T00:00:11 L7 sdb[318]: libmotopia: Closing /dev/motopia
P0000-00-00T00:00:11 L7 sdb[318]: Loading platform module bcm_enet
P0000-00-00T00:00:12 L6 sdb[318]: SSL CA-root-cert directory is ready.
P0000-00-00T00:00:12 L6 sdb[318]: Hardware is 'NVG510
P0000-00-00T00:00:13 L6 sdb[318]: S/N 153056273312, SKU 64
P0000-00-00T00:00:15 L3 sdb[318]: Wireless subsystem found
P0000-00-00T00:00:18 L5 sdb[318]: VoIP subsystem found
P0000-00-00T00:00:18 L7 sdb[318]: netfilter: redirect object not found. skip prerout
P0000-00-00T00:00:20 L6 sdb[318]: ip6.route[1]: setting state from 'unset' to 'down
P0000-00-00T00:00:20 L3 sdb[318]: Wi-Fi: Adding interface w10
P0000-00-00T00:00:20 L3 sdb[318]: Wi-Fi: Adding interface w10.1
P0000-00-00T00:00:20 L3 sdb[318]: Wi-Fi: Adding interface w10.2
P0000-00-00T00:00:20 L3 sdb[318]: Wi-Fi: Adding interface w10.3
P0000-00-00T00:00:20 L3 sdb[318]: DSL: EOC version 23a2dd63a0 NVG510 901108-64
P0000-00-00T00:00:20 L7 sdb[318]: enabling vc[1]
P0000-00-00T00:00:21 L7 sdb[318]: starting process /bin/voipexe (pid 1089)
P0000-00-00T00:00:21 L5 sdb[318]: voipexe start returned ret=0
P0000-00-00T00:00:21 L5 sdb[318]: login authorization-delay timer set for 300 seconds
P0000-00-00T00:00:21 L5 sdb[318]: SYS: no saved configuration found, using defaults
P0000-00-00T00:00:21 L6 sdb[318]: ip6_set_proc: setting to '1'
P0000-00-00T00:00:21 L6 sdb[318]: ip6_set_proc: setting to '1'
P0000-00-00T00:00:21 L6 sdb[318]: ip6_set_proc: setting to '0'
P0000-00-00T00:00:22 L7 sdb[318]: sdb_system (ret 2): tc qdisc delete dev eth0 ingress
P0000-00-00T00:00:22 L7 sdb[318]: sdb_system (ret 2): tc qdisc delete dev eth1 ingress
P0000-00-00T00:00:22 L7 sdb[318]: sdb_system (ret 2): tc qdisc delete dev eth2 ingress
P0000-00-00T00:00:23 L7 sdb[318]: sdb_system (ret 2): tc qdisc delete dev eth3 ingress
P0000-00-00T00:00:23 L7 sdb[318]: Ensw QoS: p-bit map: 0 0 0 0 1 1 2 2
P0000-00-00T00:00:23 L7 sdb[318]: Ensw QoS configured
P0000-00-00T00:00:23 L7 sdb[318]: Ensw: max age is 300
P0000-00-00T00:00:23 L3 sdb[318]: Wi-Fi: Initializing the subsystem
P0000-00-00T00:00:23 L3 sdb[318]: Wi-Fi: Starting autochannel scan...
P0000-00-00T00:00:25 L3 sdb[318]: Wi-Fi: Autochannel found channel 11 on attempt 1
P0000-00-00T00:00:25 L7 sdb[318]: starting process /sbin/eapd (pid 1170)
P0000-00-00T00:00:25 L3 sdb[318]: Wi-Fi: EAPD daemon started
P0000-00-00T00:00:25 L7 sdb[318]: starting process /sbin/nas (pid 1171)
P0000-00-00T00:00:25 L3 sdb[318]: Wi-Fi: NAS daemon started
P0000-00-00T00:00:25 L7 sdb[318]: Port ssid-1 sending UP event
P0000-00-00T00:00:25 L6 sdb[318]: DSL: TPS-TC encoding set to auto-detect.
P0000-00-00T00:00:26 L3 sdb[318]: DSL: NLNM threshold value set to 60
P0000-00-00T00:00:26 L3 sdb[318]: DSL: Bitswap is ON, SRA is ON
P0000-00-00T00:00:26 L3 sdb[318]: DSL: Dying Gasp is OFF
P0000-00-00T00:00:26 L3 sdb[318]: DSL: DSP version - A2pd0351.d24b
P0000-00-00T00:00:26 L7 sdb[318]: sdb_system (ret 2): tc qdisc delete dev ptm0 ingress
P0000-00-00T00:00:26 L5 sdb[318]: ATM: Autodetect: Setting VC 1 vpi 0 vci 35
P0000-00-00T00:00:26 L3 sdb[318]: ATM: VC 1, vpi=0, vci=35 QoS No
P0000-00-00T00:00:26 L7 sdb[318]: ATM: VC QoS No change: vpi=0 vci=35
P0000-00-00T00:00:26 L3 sdb[318]: ATM: VC vpi=0 vci=35 vc-1 atm1
P0000-00-00T00:00:26 L7 sdb[318]: sdb_system (ret 2): tc qdisc delete dev atm1 ingress
P0000-00-00T00:00:26 L5 sdb[318]: ATM: VC 2 vpi 0 vci 0 disabled
P0000-00-00T00:00:26 L5 sdb[318]: ATM: VC 3 vpi 0 vci 0 disabled
P0000-00-00T00:00:26 L5 sdb[318]: ATM: VC 4 vpi 0 vci 0 disabled
P0000-00-00T00:00:26 L5 sdb[318]: ATM: VC 5 vpi 0 vci 0 disabled
P0000-00-00T00:00:26 L5 sdb[318]: ATM: VC 6 vpi 0 vci 0 disabled
P0000-00-00T00:00:26 L5 sdb[318]: ATM: VC 7 vpi 0 vci 0 disabled
P0000-00-00T00:00:26 L5 sdb[318]: ATM: VC 8 vpi 0 vci 0 disabled
P0000-00-00T00:00:28 L7 sdb[318]: conn[1]: linkchange_handler got event 19 from link
P0000-00-00T00:00:28 L7 sdb[318]: conn[2]: linkchange_handler got event 19 from link
P0000-00-00T00:00:28 L7 sdb[318]: conn[1]: linkchange_handler got event 19 from link
```

The current status of the device is displayed for all logs: **System**, **Firewall**, or **VoIP**. Choose the log you want to display from the pull-down menu.

- ◆ You can clear all log entries by clicking the [Clear Log](#) button.
- ◆ You can save logs to a text (.TXT) file by clicking the [Save to File](#) button. This will download the file to your browser's default download location on your hard drive. The file can be opened with your favorite text editor.



NOTE:

Some browsers, such as Internet Explorer for Windows XP, require that you specify the ARRIS® device's URL as a "Trusted site" in "Internet Options: Security". This is necessary to allow the "download" of the log text file to the PC.

The following is an example log portion saved as a .TXT file:

No.	Time	Src IP	Dst IP	Proto	Reason
1	2012-03-06T12:04:56-05:00	10.8.50.176	10.8.205.145	ICMP	ICMP Echo Request
2	P0000-00-00T00:01:34	192.168.1.105	192.168.1.254	TCP	Downstream direction
3	P0000-00-00T00:05:52	192.168.1.105	192.168.1.254	TCF	Downstream direction
4	P0000-00-00T00:08:16	192.168.1.105	192.168.1.254	TCP	Downstream direction
5	2012-03-06T12:22:00-05:00	192.168.1.43	192.168.1.254	TCF	Downstream direction
6	2012-03-06T12:22:20-05:00	10.8.50.176	10.8.205.145	ICMP	ICMP Echo Request
7	2012-03-06T12:24:07-05:00	10.8.50.176	10.8.205.145	ICMP	ICMP Echo Request
8	2012-03-06T12:25:08-05:00	10.8.50.176	10.8.205.145	ICMP	ICMP Echo Request
9	2012-03-06T12:26:09-05:00	10.8.50.176	10.8.205.145	ICMP	ICMP Echo Request
10	2012-03-06T12:28:53-05:00	10.8.50.176	10.8.205.145	ICMP	ICMP Echo Request
11	P0000-00-00T00:00:39	192.168.1.255	255.255.255.255	UDP	Generic Discards
12	2012-03-06T12:33:13-05:00	10.8.50.176	10.8.205.145	ICMP	ICMP Echo Request
13	2012-03-06T12:34:17-05:00	10.8.50.176	10.8.205.145	ICMP	ICMP Echo Request
14	2012-03-06T12:35:20-05:00	10.8.50.176	10.8.205.145	ICMP	ICMP Echo Request
15	2012-03-06T12:36:24-05:00	10.8.50.176	10.8.205.145	ICMP	ICMP Echo Request
16	2012-03-06T12:37:28-05:00	10.8.50.176	10.8.205.145	ICMP	ICMP Echo Request
17	2012-03-06T11:48:18-06:00	10.8.50.176	10.8.205.145	ICMP	ICMP Echo Request
18	2012-03-06T11:49:22-06:00	10.8.50.176	10.8.205.145	ICMP	ICMP Echo Request
19	2012-03-06T11:51:17-06:00	10.8.50.176	10.8.205.145	ICMP	ICMP Echo Request
20	2012-03-06T11:52:21-06:00	10.8.50.176	10.8.205.145	ICMP	ICMP Echo Request
21	2012-03-06T11:56:18-06:00	10.8.50.176	10.8.205.145	ICMP	ICMP Echo Request
22	2012-03-06T11:57:22-06:00	10.8.50.176	10.8.205.145	ICMP	ICMP Echo Request
23	2012-03-06T11:58:26-06:00	10.8.50.176	10.8.205.145	ICMP	ICMP Echo Request
24	2012-03-06T11:59:30-06:00	10.8.50.176	10.8.205.145	ICMP	ICMP Echo Request
25	2012-03-06T12:00:33-06:00	10.8.50.176	10.8.205.145	ICMP	ICMP Echo Request
26	2012-03-06T12:05:11-06:00	10.8.50.176	10.8.205.145	ICMP	ICMP Echo Request
27	2012-03-06T12:06:15-06:00	10.8.50.176	10.8.205.145	ICMP	ICMP Echo Request
28	2012-03-06T12:07:19-06:00	10.8.50.176	10.8.205.145	ICMP	ICMP Echo Request
29	2012-03-06T12:08:23-06:00	10.8.50.176	10.8.205.145	ICMP	ICMP Echo Request
30	2012-03-06T12:09:26-06:00	10.8.50.176	10.8.205.145	ICMP	ICMP Echo Request
31	2012-03-06T10:38:03-06:00	10.8.50.176	10.8.205.145	ICMP	ICMP Echo Request
32	2012-03-06T10:39:06-06:00	10.8.50.176	10.8.205.145	ICMP	ICMP Echo Request
33	2012-03-06T10:40:10-06:00	10.8.50.176	10.8.205.145	ICMP	ICMP Echo Request
34	2012-03-06T10:41:13-06:00	10.8.50.176	10.8.205.145	ICMP	ICMP Echo Request
35	2012-03-06T10:42:17-06:00	10.8.50.176	10.8.205.145	ICMP	ICMP Echo Request
36	2012-03-08T18:28:23Z	10.43.0.156	224.0.0.1	Z	Generic Discards
The last message was repeated 14 times.					
38	2012-03-09T12:48:24Z	10.43.0.156	224.0.0.1	Z	Generic Discards
The last message was repeated 13 times.					
40	2012-03-09T13:24:55Z	10.17.219.52	50.30.8.46	TCP	Downstream direction
41	2012-03-09T13:25:54Z	10.43.0.156	224.0.0.1	Z	Generic Discards
42	2012-03-09T13:30:04Z	10.43.0.156	224.0.0.1	Z	Generic Discards
43	2012-03-09T13:32:09Z	10.43.0.156	224.0.0.1	Z	Generic Discards
44	2012-03-09T13:32:18Z	192.168.1.65	74.125.225.133	TCP	Downstream direction
45	2012-03-09T13:34:14Z	10.43.0.156	224.0.0.1	Z	Generic Discards
46	2012-03-09T13:36:19Z	10.43.0.156	224.0.0.1	Z	Generic Discards
47	2012-03-09T13:38:24Z	10.43.0.156	224.0.0.1	Z	Generic Discards
48	2012-03-09T13:42:34Z	10.43.0.156	224.0.0.1	Z	Generic Discards
49	2012-03-09T13:59:14Z	10.43.0.156	224.0.0.1	Z	Generic Discards
50	2012-03-09T10:09:58-05:00	192.168.1.65	69.171.228.21	TCP	Downstream direction
51	P0000-00-00T00:00:39	192.168.1.43	192.168.1.255	UDP	Generic Discards

Link: Update

When you click [Update](#), the Update page opens.

Operating System Software is what makes your Gateway run and occasionally it needs to be updated. Your **Current software version** is displayed at the top of the page.



To update your software from a file on your PC, you must first download the software from your Service Provider's Support Site to your PC's hard drive.

- ◆ [Browse](#) your computer for the operating system file you downloaded and select the file.
- ◆ Click the [Update](#) button.
 - The LEDs will operate normally as described in [“Status Indicator Lights” on page 92](#).
- ◆ The installation may take a few minutes and the web page will indicate a 3-part countdown before returning you to the Home page; wait for it to complete. During the software installation, you will lose Internet and phone service. The LEDs will function as follows:
 - During this phase, the LEDs will function as follows:
 - During this phase, the **Power** LED will flash **Orange/Amber** during firmware upgrade (flash writing to memory) and all other LEDs will be off.
- ◆ The Gateway will restart automatically.
 - As the device reboots, the POWER ON LED behavior will happen.
- ◆ Your new operating system will then be running.

Link: Resets

When you click [Resets](#), the **Resets** page opens.

In some cases, you may need to clear all the configuration settings and start over again to program the ARRIS® Gateway. You can perform a factory reset to do this.

It might also be useful to reset your connection to the Internet without deleting all of your configuration settings.

- ◆ Click the [Reset IP](#) to refresh your Internet WAN IP address. LAN-side users will be briefly disconnected from the Internet, but will otherwise be unaffected.
- ◆ Click the [Reset Connection](#) button to disconnect and reconnect all of your connections, including your VoIP phones.
- ◆ Click the [Reset Device](#) button to reset the Gateway back to its original factory default settings.
- ◆ Click the [Restart](#) button to reboot the device. Previous configuration settings are still retained.

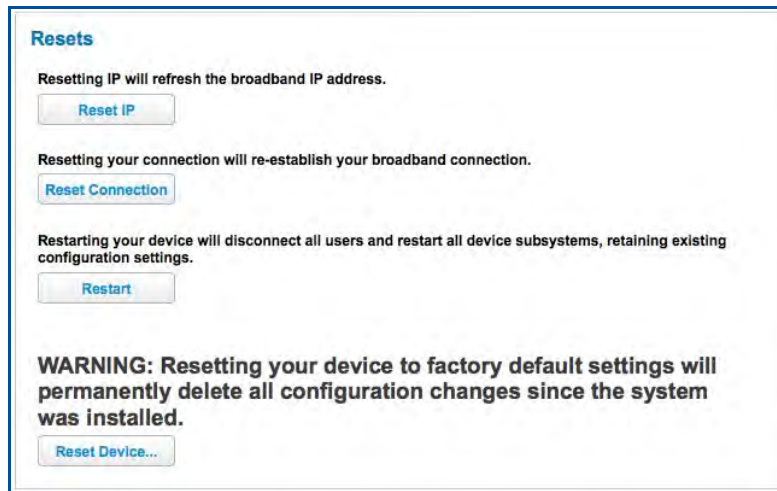

NOTE:

Exercise caution before performing a Factory Reset. This will erase any configuration changes that you may have made and allow you to reprogram your Gateway.

Link: Syslog

When you click the [Syslog](#) link the **Syslog** configuration page opens. You can configure a UNIX-compatible (BSD syslog protocol - RFC 3164) syslog client to report a number of subsets of the events entered in the device's logs.

The screenshot shows the Syslog configuration page in the AT&T/ARRIS web interface. The page has a navigation bar with tabs for Device, Broadband, Local Network, Voice, Firewall, and Diagnostics. The Syslog tab is selected. The configuration options are as follows:

- Syslog: Off (dropdown)
- Server IP Address: (text input field)
- Server Port: 514 (text input field)
- Facility: Local0 (dropdown)
- Log Level: Notice (dropdown)
- System Log: On (dropdown)
- Firewall Log: Off (dropdown)
- Voice Log: Off (dropdown)

At the bottom of the configuration area are 'Save' and 'Cancel' buttons. To the right of the configuration area is a 'Help' section with the following text:

Help

The syslog function, if enabled, sends log messages to the specified Server IP Address using the specified Server Port. You must have a UNIX-compatible syslog client for this feature.

Facility: Syslog allows programs to supply an identifying Facility string that syslog will prepend to each log message. This allows easy selection of the log messages in interest.

Log Level: This level is the severity level of logs sent to the syslog client. The severity level of the system may be more inclusive than that of the syslog. The levels in decreasing order of severity are:

1. Emergency
2. Alert
3. Critical
4. Error
5. Warning
6. Notice
7. Info
8. Debug

Log Types: You can turn on/off various categories of syslog entries.

- ◆ You can enable or disable the Syslog client dynamically. When enabled, it will report any appropriate and previously unreported events.
- ◆ You can specify the Syslog server's address and port, if required, either in dotted decimal format or as a DNS name up to 63 characters.
- ◆ You can specify the UNIX syslog **Facility** to use by selecting from the Facility pull-down menu.
- ◆ From the pull-down menu, you specify the **Log Level** in decreasing severity level: Emergency, Alert, Critical, Error, Warning, Notice, Info, or Debug.
- ◆ By toggling each event descriptor to either **On** or **Off**, you can determine which ones are logged and which are ignored.

You will need to install a Syslog client daemon program on your PC and configure it to report the events you specified in the Syslog configuration screen.

Click the [Save](#) button.

Link: Event Notifications

When you click [Event Notifications](#), the **Event Notifications** page opens.

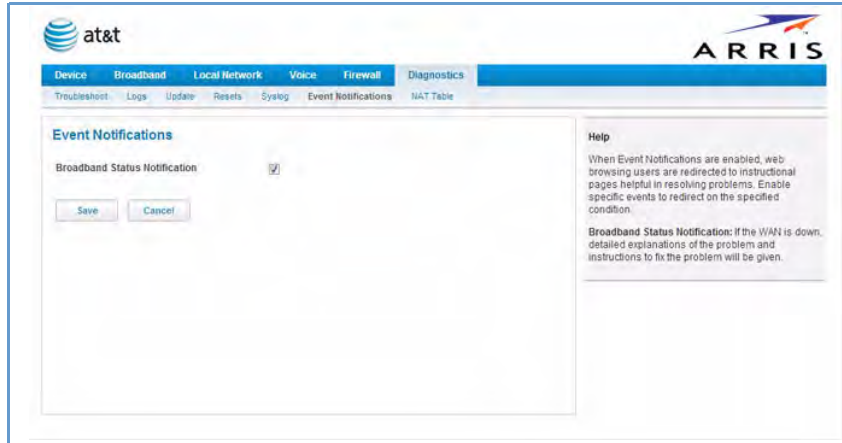

- ◆ If you check the **Broadband Status Notification** checkbox, the device will alert users on your network if the connection to the Internet should fail. In that event, troubleshooting suggestions will display.

Link: NAT Table

When you click the [NAT Table](#) link, the **NAT Table** page opens.

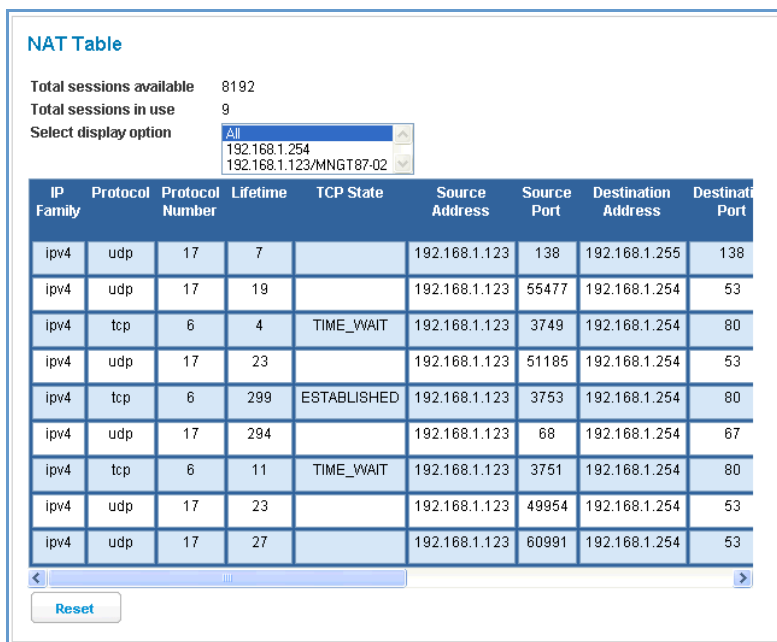

The screenshot shows the NAT Table page with the following statistics:

- Total sessions available: 8192
- Total sessions in use: 9
- Select display option: A dropdown menu with options: All, 192.168.1.254, and 192.168.1.123/MNGT87-02.

IP Family	Protocol	Protocol Number	Lifetime	TCP State	Source Address	Source Port	Destination Address	Destination Port
ipv4	udp	17	7		192.168.1.123	138	192.168.1.255	138
ipv4	udp	17	19		192.168.1.123	55477	192.168.1.254	53
ipv4	tcp	6	4	TIME_WAIT	192.168.1.123	3749	192.168.1.254	80
ipv4	udp	17	23		192.168.1.123	51185	192.168.1.254	53
ipv4	tcp	6	299	ESTABLISHED	192.168.1.123	3753	192.168.1.254	80
ipv4	udp	17	294		192.168.1.123	68	192.168.1.254	67
ipv4	tcp	6	11	TIME_WAIT	192.168.1.123	3751	192.168.1.254	80
ipv4	udp	17	23		192.168.1.123	49954	192.168.1.254	53
ipv4	udp	17	27		192.168.1.123	60991	192.168.1.254	53

At the bottom of the table, there is a search bar with a "Reset" button.

The NAT Table page displays the network address translation sessions in use by the Gateway. You can use the pull-down menu to limit the displayed sessions to selected IP addresses.

To refresh all the sessions displayed, click the [Reset](#) button.

CHAPTER 3 Basic Troubleshooting

This section gives some simple suggestions for troubleshooting problems with your Gateway's initial configuration.

Before troubleshooting, make sure you have

- ◆ read the User Manual;
- ◆ plugged in all the necessary cables
- ◆ set your PC's TCP/IP controls to obtain an IP address automatically.

Status Indicator Lights

The first step in troubleshooting is to check the status indicator lights (LEDs) in the order outlined below.

ARRIS® Gateway NVG595 status indicator lights

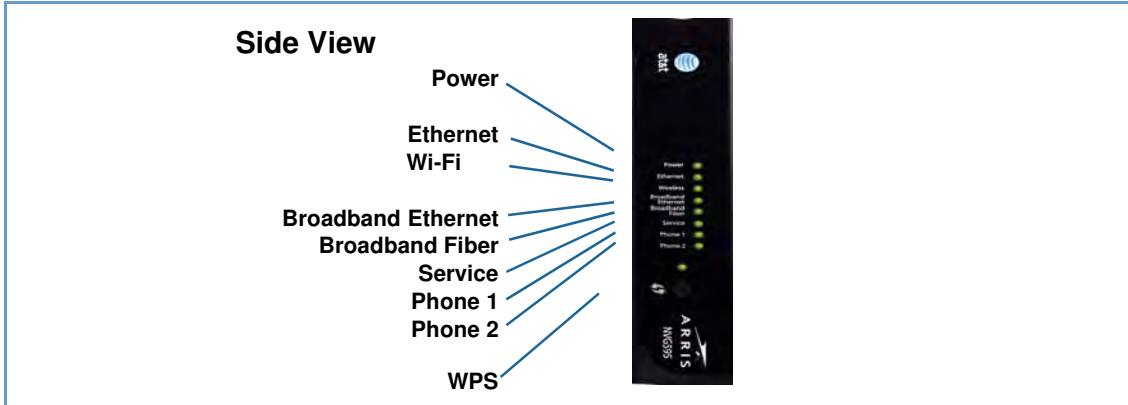

LED	Action
Power*	<p>Solid Green = The device is powered.</p> <p>Flashing Green = A Power-On Self-Test (POST) is in progress</p> <p>Flashing Red = A POST failure (not bootable) or device malfunction occurred.</p> <p>Orange/Amber = during firmware upgrade (see below)</p> <p>Off = The unit has no AC power.</p>
*During Firmware Upgrade	<p>During the software installation, you will lose internet and phone service. The LEDs will function as follows:</p> <ol style="list-style-type: none"> As firmware is being loaded into flash, the LEDs will operate normally as described. The installation will take a few minutes – During this phase, the Power LED will flash Orange/Amber during firmware upgrade (flash writing to memory) and all other LEDs will be off. The Gateway will restart automatically. As the device reboots, the POWER ON LED behavior will happen.
During Boot process	<ul style="list-style-type: none"> Power LED = GREEN/FLASH All other LED = OFF <p>If the device does not boot, and fails its self test or fails to perform initial load of the bootloader:</p> <ul style="list-style-type: none"> Power LED = RED/FLASH ALL other LED = OFF <p>If the device boots and then detects a failure:</p> <p>Power LED = GREEN/FLASH starting POST and then all LEDs will FLASH RED, including Power LED.</p>
Ethernet	<p>Solid Green = Powered device connected to the associated port (includes devices with wake-on-LAN capability where a slight voltage is supplied to the Ethernet connection).</p> <p>Flickering Green = Activity seen from devices associated with the port. The flickering of the light is synchronized to actual data traffic.</p> <p>Off = The device is not powered, no cable or no powered devices connected to the associated ports.</p>
Wi-Fi	<p>Solid Green = Wi-Fi is powered.</p> <p>Flickering Green = Activity seen from devices connected via Wi-Fi. The flickering of the light is synchronized to actual data traffic.</p> <p>Off = The device is not powered or no powered devices connected to the associated ports.</p>

LED	Action
Broadband Ethernet	<p>Solid Green = Good broadband connection.</p> <p>Flashing Green & Red = If the broadband connection fails to be established for more than three consecutive minutes the LED switches to Flashing Green when attempting or waiting to establish a broadband connection alternating with a five second steady Red. This pattern continues until the broadband connection is successfully established.</p> <p>Flashing Red = No signal on the line. This is only used when there is no signal, not during the training sequence.</p> <p>Off = The device is not powered.</p>
Broadband Fiber	<p>Solid Green = Good broadband connection.</p> <p>Flashing Green & Red = If the broadband connection fails to be established for more than three consecutive minutes the LED switches to Flashing Green when attempting or waiting to establish a broadband connection alternating with a five second steady Red. This pattern continues until the broadband connection is successfully established.</p> <p>Flashing Red = No signal on the line. This is only used when there is no signal, not during the training sequence.</p> <p>Off = The device is not powered.</p>
Service	<p>Solid Green = IP connected (The device has a WAN IP address from DHCP or 802.1x authentication and the broadband connection is up).</p> <p>Flashing Green = Attempting connection, attempting IEEE 802.1X authentication or attempting to obtain DHCP information.</p> <p>Red = Device attempted to become IP connected and failed (no DHCP response, 802.1x authentication failed, no IP address from IPCP, etc.). The Red state times out after two minutes and the Service indicator light returns to the Off state.</p> <p>Off = The device is not powered or the broadband connection is not present.</p>
Phone 1, 2	<p>Solid Green = The associated VoIP line has been registered with a SIP proxy server.</p> <p>Flashing Green = Indicates a telephone is off-hook on the associated VoIP line.</p> <p>Off = VoIP not in use, line not registered or Gateway power off.</p>
WPS (opens after using WPS button) 	<p>Solid Green = Wi-Fi Protected Setup has been completed successfully. It should stay on for 5 minutes or until push button is pressed again.</p> <p>Flashing Green = for 2 mins. Indicates when WPS is broadcasting.</p> <p>Flashing Red = for 2 min, when there is a Session overlap detected (possible security risk) in Scenario.</p> <p>Solid Red = on Error unrelated to security, such as failed to find any partner, or protocol prematurely aborted. It should stay Solid Red for 5 min or until push button is pressed again.</p> <p>Off = WPS is not active, the device is not powered, no cable or no powered devices connected to the associated ports.</p>

ARRIS® Gateway NVG595 Rear View

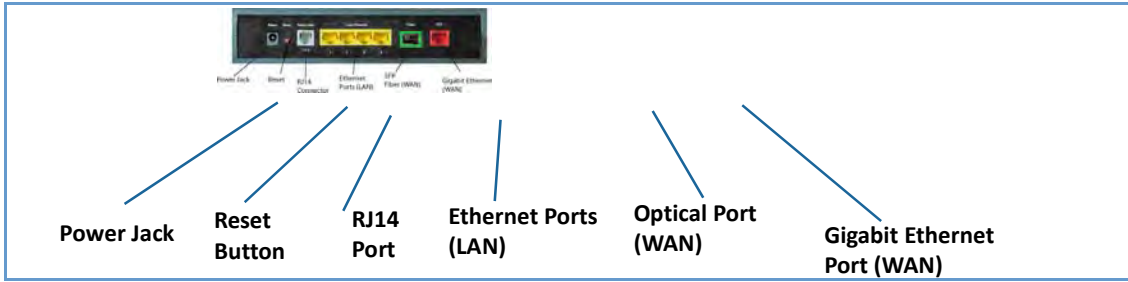

LED	Action
Ethernet 1,2,3,4	<p>Orange/Amber when a Gigabit Ethernet device is connected to each port.</p> <p>Green when 10/100 Ethernet device is connected.</p> <p>Flash for Ethernet traffic passing.</p> <p>Off = The device is not powered, or no powered devices connected to the associated ports.</p>



NOTE:

The NVG595 supports two VoIP lines over one RJ14 VoIP port. In order to connect two phone lines the supplied inner/outer pair splitter adapters must be attached to the RJ14 VoIP port in order to terminate both lines. This is a special-purpose splitter. You must only use the inner/outer pair splitter adapters supplied by AT&T.



LED Function Summary Matrix

<p>Power</p>	<p>Solid Green = The device is powered.</p>	<p>Flashing Green = A Power-On Self-Test (POST) is in progress</p>	<p>Orange/Amber = during firmware upgrade (see “*During Firmware Upgrade” on page 92)</p>	<p>Flashing Red = A POST failure (not bootable) or device malfunction occurred. * When the device encounters a POST failure, all indicator lights on the front of the device continuously flash.</p>	<p>Off = The unit has no AC power.</p>
<p>Ethernet LAN</p>	<p>Solid Green = Powered device connected to the associated port (includes devices with wake-on-LAN capability where a slight voltage is supplied to the Ethernet connection).</p>	<p>Flashing Green = Activity seen from devices associated with the port. The flickering of the light is synchronized to actual data traffic.</p>			<p>Off = The device is not powered, no cable or no powered devices connected to the associated ports.</p>
<p>Broadband Ethernet</p>	<p>Solid Green = Powered device connected to the associated port (includes devices with wake-on-LAN capability where a slight voltage is supplied to the Ethernet connection).</p>	<p>Flashing Green = Activity seen from devices associated with the port. The flickering of the light is synchronized to actual data traffic.</p>		<p>Flashing Green and Red = if the broadband connection fails to be established for more than three consecutive minutes the LED switches to flashing green when attempting or waiting to establish a broadband connection alternating with a five second steady Red. This pattern continues until the connection is established</p>	<p>Off = The device is not powered, no cable or no powered devices connected to the associated ports.</p>

<p>Broadband Wi-Fi</p>	<p>Solid Green = Wi-Fi is powered.</p>	<p>Flashing Green = Activity seen from devices connected via Wi-Fi. The flickering of the light is synchronized to actual data traffic.</p>		<p>Flashing Green and Red = if the broadband connection fails to be established for more than three consecutive minutes the LED switches to flashing green when attempting or waiting to establish a broadband connection alternating with a five second steady Red. This pattern continues until the connection is established</p>	<p>Off = The device is not powered or no powered devices connected to the associated ports.</p>
<p>Service</p>	<p>Solid Green = IP connected (The device has a WAN IP address from DHCP or 802.1x authentication and the broadband connection is up).</p>	<p>Flashing Green = Attempting PPP connection.p Attempting IEEE 802.1X authentication or attempting to obtain DHCP information.</p>		<p>Red = Device attempted to become IP connected and failed (no DHCP response, 802.1x authentication failed, no IP address from IPCP, etc.). The Red state times out after two minutes and the Service indicator light returns to the Off state.</p>	<p>Off = The device is not powered or the broadband connection is not present.</p>
<p>Phone 1, 2</p>	<p>Solid Green = The associated VoIP line has been registered with a SIP proxy server.</p>	<p>Flashing Green = Indicates a telephone is off-hook on the associated VoIP line.</p>			<p>Off = VoIP not in use, line not registered or Gateway power off.</p>
<p>WPS</p>	<p>Solid Green = Wi-Fi Protected Setup has been completed successfully. It should stay on for 5 minutes or until push button is pressed again.</p>	<p>Flashing Green = Indicates when WPS is broadcasting.</p>	<p>Solid Red = Error unrelated to security, such as failed to find any partner, or protocol prematurely aborted. It should stay Solid Red for 5 min or until push button is pressed again.</p>	<p>Flashing Red = Session overlap detected (possible security risk) in Scenario.</p>	<p>Off = WPS is not active, the device is not powered, no cable or no powered devices connected to the associated ports.</p>

If a status indicator light does not look correct, look for these possible problems:

If LED is not Lit	Possible problems
Power	<ul style="list-style-type: none">◆ Make sure the power adapter is plugged into the Modem properly.◆ Try a known good wall outlet.◆ If a power strip is used, make sure it is switched on.
Broadband	<ul style="list-style-type: none">◆ Make sure the WAN ethernet or Fiber cable is connected to the modem properly.
Ethernet	<ul style="list-style-type: none">◆ Make sure the Ethernet cable is securely plugged into the Ethernet jack on the PC.◆ Make sure the Ethernet cable is securely plugged into the Ethernet port on the Modem.◆ Make sure you have Ethernet drivers installed on the PC.◆ Make sure the PC's TCP/IP Properties for the Ethernet Network Control Panel is set to obtain an IP address via DHCP.◆ Make sure the PC has obtained an address in the 192.168.1.x range. (You may have changed the subnet addressing.)◆ Make sure the PC is configured to access the Internet over a LAN.◆ Disable any installed network devices (Ethernet, Wi-Fi) that are not being used to connect to the Modem.

Factory Reset Switch

If you lose your access code the following section shows how to reset the ARRIS® Gateway so that you can access the configuration screens once again.



NOTE: Keep in mind that all of your settings will need to be reconfigured.

If you don't have an Access Code, the only way to access the ARRIS® Gateway is the following:

1. Referring to the diagram below, find the round Factory Reset Switch.

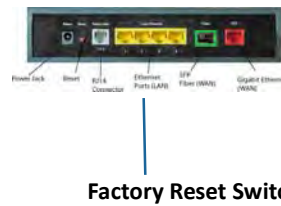

2. Carefully press the reset switch.

- ◆ If you press the factory reset button for **less than ten (10) seconds**, the device will be rebooted. The indicator lights on the device will respond immediately and start blinking red within one (1) second of the reset button being pressed. This will occur independent of the fact that the button is still being pressed or has been released. The indicator lights will flash for a minimum of five seconds, even if the reset button is released prior to five seconds after it has been depressed. If the reset button is held for more than 5 seconds, then it will continue to flash until released or until 10 seconds (see below).
- ◆ If you press the factory reset button for a **longer period of time**, the device will be reset to the factory default shipped settings. If the button is held for ten seconds, the Power indicator continues to flash, for an additional 5 seconds and then the indicator lights will return to their normal operating mode, independent of whether or not the reset button is still depressed.

Administration Related Log Messages

- 1. administrative access attempted:** This log-message is generated whenever the user attempts to access the router's management interface.
- 2. administrative access authenticated and allowed:** This log-message is generated whenever the user attempts to access the router's management interface and is successfully authenticated and allowed access to the management interface.
- 3. administrative access allowed:** If for some reason, a customer does not want password protection for the management interface, this log-message is generated whenever any user attempts to access the router's management interface and is allowed access to the management interface.
- 4. administrative access denied - invalid user name:** This log-message is generated whenever the user tries to access the router's management interface and authentication fails due to incorrect user-name.
- 5. administrative access denied - invalid password:** This log-message is generated whenever the user tries to access the router's management interface and authentication fails due to incorrect password.
- 6. administrative access denied - telnet access not allowed:** This log-message is generated whenever the user tries to access the router's Telnet management interface from a Public interface and is not permitted since Remote Management is disabled.
- 7. administrative access denied - web access not allowed:** This log-message is generated whenever the user tries to access the router's HTTP management interface from a Public interface and is not permitted since Remote Management is disabled.

System Log Messages

- 1. Received NTP Date and Time:** This log-message is generated whenever NTP receives Date and time from the server.
- 2. EN: IP up:** This log-message is generated whenever Ethernet WAN comes up.
- 3. WAN: Ethernet WAN1 activated at 100000 Kbps:** This log-message is generated when the Ethernet WAN Link is up.
- 4. Device Restarted:** This log-message is generated when the router has been restarted.

Access-related Log Messages

- 1. permitted:** This log-message is generated whenever a packet is allowed to traverse router-interfaces or allowed to access the router itself.
- 2. attempt:** This log-message is generated whenever a packet attempts to traverse router-interfaces or attempts to access the router itself.
- 3. dropped - violation of security policy:** This log-message is generated whenever a packet, traversing the router or destined to the router itself, is dropped by the firewall because it violates the expected conditions.
- 4. dropped - invalid checksum:** This log-message is generated whenever a packet, traversing the router or destined to the router itself, is dropped because of invalid IP checksum.
- 5. dropped - invalid data length:** This log-message is generated whenever a packet, traversing the router or destined to the router itself, is dropped because the IP length is greater than the received packet length or if the length is too small for an IP packet.
- 6. dropped - fragmented packet:** This log-message is generated whenever a packet, traversing the router, is dropped because it is fragmented, stateful inspection is turned ON on the packet's transmit or receive interface, and deny-fragment option is enabled.
- 7. dropped - cannot fragment:** This log-message is generated whenever a packet traversing the router is dropped because the packet cannot be sent without fragmentation, but the do not fragment bit is set.
- 8. dropped - no route found:** This log-message is generated whenever a packet, traversing the router or destined to the router itself, is dropped because no route is found to forward the packet.
- 9. dropped - invalid IP version:** This log-message is generated whenever a packet, traversing the router or destined to the router itself, is dropped because the IP version is not 4.
- 10. dropped - possible land attack:** This log-message is generated whenever a packet, traversing the router or destined to the router itself, is dropped because the packet is TCP/UDP packet and source IP Address and source port equals the destination IP Address and destination port.
- 11. TCP SYN flood detected:** This log-message is generated whenever a SYN packet destined to the router's management interface is dropped because the number of SYN-sent and SYN-receives exceeds one half the number of allowable connections in the router.
- 12. Telnet receive DoS attack - packets dropped:** This log-message is generated whenever TCP packets destined to the router's telnet management interface are dropped due to overwhelming receive data.
- 13. dropped - reassembly timeout:** This log-message is generated whenever packets, traversing the router or destined to the router itself, are dropped because of reassembly timeout.
- 14. dropped - illegal size:** This log-message is generated whenever packets, traversing the router or destined to the router itself, are dropped during reassembly because of illegal packet size in a fragment.

Firewall Log Messages Detail (AT&T requirement #841)

Reason Enumeration (C)	Log Text Representation	Why the packet was logged
NM_LOGDROP_CAT_DIR	DIRECTION	Direction (generic)
NM_LOGDROP_CAT_DIR_UP	DIRECTION-UP	Upstream direction
NM_LOGDROP_CAT_DIR_DOWN	DIRECTION-DOWN	Downstream direction
NM_LOGDROP_CAT_ETH	ETH	Ethernet Header (generic)
NM_LOGDROP_CAT_ETH_SRC_ADDR	ETH-SRC	Ethernet Source MAC Address
NM_LOGDROP_CAT_ETH_DST_ADDR	ETH-DST	Ethernet Destination MAC Address
NM_LOGDROP_CAT_ETH_PROT	ETH-PROTOCOL	Ethernet Protocol
NM_LOGDROP_CAT_ETH_VLAN	ETH-VLAN	Ethernet VLAN ID (where applicable)
NM_LOGDROP_CAT_IP	IP	IP Header (generic)
NM_LOGDROP_CAT_IP_SRC	IP-SRC	IP Source Address
NM_LOGDROP_CAT_IP_DST	IP-DST	IP Destination Address
NM_LOGDROP_CAT_IP_PROT	IP-PROTOCOL	IP Protocol
NM_LOGDROP_CAT_IP_SPOOF	IP-SPOOF	IP Address is spoofed (could not have been sent by a device legitimately with the address in the source address field)
NM_LOGDROP_CAT_IP_ILL	IP-ILLEGAL	IP Address is illegal (either src or dest)
NM_LOGDROP_CAT_TCP	TCP	TCP Header (generic)
NM_LOGDROP_CAT_TCP_SRC_PORT	TCP-SRC-PORT	TCP Source Port
NM_LOGDROP_CAT_TCP_DST_PORT	TCP-DST-PORT	TCP Destination Port
NM_LOGDROP_CAT_TCP_FLAGS	TCP-FLAGS	TCP Flags field
NM_LOGDROP_CAT_UDP	UDP	UDP Header (generic)
NM_LOGDROP_CAT_UDP_SRC_PORT	UDP-SRC-PORT	UDP Source Port
NM_LOGDROP_CAT_UDP_DST_PORT	UDP-DST-PORT	UDP Destination Port
NM_LOGDROP_CAT_ICMP	ICMP	ICMP Packet (generic)
NM_LOGDROP_CAT_ICMP_TYPE	ICMP-TYPE	ICMP Type Field
NM_LOGDROP_CAT_ICMP_CODE	ICMP-CODE	ICMP Code Field
NM_LOGDROP_CAT_ICMP6	ICMPv6	ICMPv6 (generic)
NM_LOGDROP_CAT_POLICY	POLICY	Policy (generic). This currently includes filterset rules, restricted hosts, IPv6 Profiles.
NM_LOGDROP_CAT_POLICY_INPUT	POLICY-INPUT-GEN-DISCARD	Packets destined for the CPE that are generically discarded (we specify the packets we DO want; the rest are discarded.)
NM_LOGDROP_CAT_POLICY_WAN_MGMT	POLICY-WAN-MGMT-ACCESS	1) Trying to access CPE service from WAN side using LAN-side port 2) Trying to access CPE service from LAN side using WAN-side IP address 3) Trying to access CPE service from WAN side using IPv6

Firewall Log Messages Detail (AT&T requirement #841)

Reason Enumeration (C)	Log Text Representation	Why the packet was logged
NM_LOGDROP_CAT_POLICY_ICMP_ECHO	POLICY-ICMP-ECHO	ICMP Echo Request discarded (more specific than NM_LOGDROP_CAT_ICMP_TYPE)
NM_LOGDROP_CAT_POLICY_UWC_RESTRICT	POLICY-UWC-RESTRICT	Packets dropped because of "Universal Wi-Fi Configuration" restrictions (currently unused)
NM_LOGDROP_CAT_POLICY_RESTRICTED_HOST	POLICY-RESTRICTED-HOST	Packets dropped because of "Restricted Host" feature (either content or time restrictions) (currently unused)
NM_LOGDROP_CAT_POLICY_WAN_DNS_QUERY	POLICY-WAN-SIDE-DNS-QUERY	DNS query packets received on a WAN interface
NM_LOGDROP_CAT_POLICY_WAN_DHCP_TO_SRVR	POLICY-WAN-SIDE-DHCP-TO-SRVR	DHCP DISCOVER/REQUEST received on a WAN interface
NM_LOGDROP_CAT_POLICY_AH	POLICY-IPV6-AH	IPv6 Packets with AH Header (if so configured)
NM_LOGDROP_CAT_POLICY_ESP	POLICY-IPV6-ESP	IPv6 Packets with ESP Header (if so configured)
NM_LOGDROP_CAT_POLICY_DEP_HEADER	POLICY-DEPRECATED-HEADER	IPv6 Packets with deprecated header (currently this only includes routing extension header type 0)
NM_LOGDROP_CAT_POLICY_CAPT_PORTAL	POLICY-CAPTIVE-PORTAL	[IPv6] Packets dropped because captive portal is enabled.
NM_LOGDROP_CAT_FLOW	FLOW	Packets rejected as a result of analysis of multiple related packets (generic)
NM_LOGDROP_CAT_FLOW_FLOOD	FLOOD	Packets rejected because of flood-limiting
NM_LOGDROP_CAT_FLOW_PORTSCAN	PORTSCAN	Packets rejected because of Portscan detection
NM_LOGDROP_CAT_FLOW_DOS_OTHER	OTHER-DoS	Packets rejected because of other DoS detection. Currently this includes downstream flows that don't generate upstream responses - specifically addressing IPv6 Neighbor Discovery DoS attacks.

CHAPTER 4 Command Line Interface

The ARRIS® Gateway operating software includes a command line interface (CLI) that lets you access your ARRIS® Gateway over a telnet connection. You can use the command line interface to enter and update the unit's configuration settings, monitor its performance, and restart it.

This chapter covers the following topics:

- ◆ [“Overview” on page 105](#)
- ◆ [“Starting and Ending a CLI Session” on page 107](#)
- ◆ [“Using the CLI Help Facility” on page 108](#)
- ◆ [“About SHELL Commands” on page 108](#)
- ◆ [“SHELL Commands” on page 109](#)
- ◆ [“About CONFIG Commands” on page 119](#)
- ◆ [“CONFIG Commands” on page 122](#)
- ◆ [“Debug Commands” on page 174](#)

CONFIG Commands

- ["Connection commands" on page 122](#)
- ["Filterset commands" on page 126](#)
- ["Queue commands" on page 130](#)
- ["IP Gateway commands" on page 133](#)
- ["IPv6 Commands" on page 133](#)
- ["IP DNS commands" on page 140](#)
- ["IP IGMP commands" on page 140](#)
- ["NTP commands" on page 143](#)
- ["Application Layer Gateway \(ALG\) commands" on page 143](#)
- ["Dynamic DNS Commands" on page 144](#)
- ["Link commands" on page 144](#)
- ["Management commands" on page 147](#)
- ["Remote access commands" on page 149](#)
- ["Physical interfaces commands" on page 151](#)
- ["PPPoE relay commands" on page 154](#)
- ["NAT Pinhole commands" on page 154](#)
- ["Security Stateful Packet Inspection \(SPI\) commands" on page 155](#)
- ["VoIP commands" on page 157](#)
- ["System commands" on page 169](#)

Overview

The CLI has two major command modes: **SHELL** and **CONFIG**. **Summary tables** that list the commands are provided below. Details of the entire command set follow in this section.

SHELL Commands	
Command	Status and/or Description
arp	to send ARP request
clear	to erase all stored configuration information
clear_certificate	to remove an SSL certificate that has been installed
clear_https_certkey	to remove a secure HTTP certificate key value
clear_firewall_log	to empty the contents of the firewall event log
clear_log	to erase all stored log info in flash memory
configure	to configure unit's options
diagnose	to run self-test
download	to download config file
exit	to quit this shell
ffbb	to show the number of POST fault states
help	to get more: "help all" or "help help"
install	to download and program an image into flash
log	to add a message to the diagnostic log
loglevel	to report or change diagnostic log level
netstat	to show IP information
nslookup	to send DNS query for host
ping	to send ICMP Echo request
quit	to quit this shell
6rd-check	to send a 6rd loopback packet to the border gateway
reset	to reset subsystems
restart	to restart unit
show	to show system information
start	to start subsystem
status	to show basic status of unit
telnet	to telnet to a remote host
traceroute	to send traceroute probes
upload	to upload config file
view	to show configuration information
who	to show who is using the shell
wps	to enter Wi-Fi Protection Settings mode

CONFIG Commands	
Command Verbs	Status and/or Description
delete	Delete configuration list data
help	Help command option
save	Save configuration data
script	Print configuration data
set	Set configuration data
validate	Validate configuration settings
view	View configuration data
Keywords	
conn	Connection options
ip	TCP/IP protocol options
ip6	IPv6 protocol options
dns	Domain Name System options
gfs	Global Filter Set options
igmp	IGMP configuration options
ntp	Network Time Protocol options
gateway	Gateway options
link	WAN link options
management	System management options
physical	Physical interface options
enet	Ethernet options
pinhole	Pinhole options
pppoe-relay	Point to Point Protocol over Ethernet relay options
preferences	Shell environment preferences
queue	Queue options
security	Security (firewall) options
system	Gateway's system options
target-ad-insertion	Targeted Ad Insertion (TAI) options
voip	IP Voice (VoIP) configuration options
log	System activity logging options
Command Utilities	
top	Go to top level of configuration mode
quit	Exit from configuration mode; return to shell mode
exit	Exit from configuration mode; return to shell mode

Starting and Ending a CLI Session

Open a telnet connection from a workstation on your network.

You initiate a telnet connection by issuing the following command from an IP host that supports telnet, for example, a personal computer running a telnet application such as NCSA Telnet.

```
telnet <ip_address>
```

You must know the IP address of the ARRIS® Gateway before you can make a telnet connection to it. By default, your ARRIS® Gateway uses 192.168.7.254 as the IP address for its LAN interface. You can use a Web browser to configure the ARRIS® Gateway IP address.

Logging In

The command line interface log-in process emulates the log-in process for a UNIX host. To logon, enter the username and your password.

Entering the administrator password lets you display and update all ARRIS® Gateway settings.

When you have logged in successfully, the command line interface lists the username and the security level associated with the password you entered in the diagnostic log.

Ending a CLI Session

You end a command line interface session by typing **quit** from the SHELL node of the command line interface hierarchy.

Using the CLI Help Facility

The **help** command lets you display on-line help for SHELL and CONFIG commands. To display a list of the commands available to you from your current location within the command line interface hierarchy, enter **help** or type a question mark (?).

To obtain help for a specific CLI command, type **help <command>**. You can truncate the **help** command to **h** or a question mark when you request help for a CLI command.

About SHELL Commands

You begin in SHELL mode when you start a CLI session. SHELL mode lets you perform the following tasks with your ARRIS Gateway:

- ◆ Monitor its performance
- ◆ Display and reset Gateway statistics
- ◆ Issue administrative commands to restart ARRIS® Gateway functions

SHELL Prompt

When you are in SHELL mode, the CLI prompt is the name of the ARRIS® Gateway followed by a right angle bracket (>). For example, if you open a CLI connection to the ARRIS® Gateway named "ARRIS-3000/9437188," you would see **ARRIS-3000/9437188>** as your CLI prompt.

SHELL Command Shortcuts

You can **truncate** most commands in the CLI to their shortest unique string. For example, you can use the truncated command **q** in place of the full **quit** command to exit the CLI. However, you would need to enter **rese** for the **reset** command, since the first characters of **reset** are common to the **restart** command.

The only commands you cannot truncate are **restart** and **clear**. To prevent accidental interruption of communications, you must enter the **restart** and **clear** commands in their entirety.

You can use the Up and Down arrow keys to scroll backward and forward through recent commands you have entered. Alternatively, you can use the **!!** command to repeat the last command you entered.

SHELL Commands

Common Commands

arp *nnn.nnn.nnn.nnn*

Sends an Address Resolution Protocol (ARP) request to match the *nnn.nnn.nnn.nnn* IP address to an Ethernet hardware address.

clear [*yes*]

Clears the configuration settings in a ARRIS® Gateway. You are prompted to confirm the clear command by entering **yes**.

clear_certificate

Removes an SSL certificate that has been installed.

clear_https_certkey

Removes any Secure HTTP certificate key value installed in the ARRIS® Gateway.

configure

Puts the command line interface into Configure mode, which lets you configure your ARRIS® Gateway with Config commands. Config commands are described starting on [page 122](#).

download [*server_address*] [*filename*] [**confirm]**

This command installs a file of configuration parameters into the ARRIS Gateway from a TFTP (Trivial File Transfer Protocol) server. The TFTP server must be accessible on your Ethernet network.

You can include one or more of the following arguments with the download command. If you omit arguments, the console prompts you for this information.

- ◆ The *server_address* argument identifies the IP address of the TFTP server from which you want to copy the ARRIS® Gateway configuration file.
- ◆ The *filename* argument identifies the path and name of the configuration file on the TFTP server.
- ◆ If you include the optional **confirm** keyword, the download begins as soon as all information is entered.

You can also download an SSL certificate file from a trusted Certification Authority (CA), on platforms that support SSL, as follows:

```
download [-cert] [server_address] [filename] [confirm]
```

ffbb

Displays the number of times that the ARRIS® Gateway has entered a Power On Self Test (POST) fault state.

install [*server_address*] [*filename*] [**confirm]**

Downloads a new version of the ARRIS® Gateway operating software from a TFTP (Trivial File Transfer Protocol) server, validates the software image, and programs the image into the ARRIS® Gateway memory. After you install new operating software, you must restart the ARRIS® Gateway.

The *server_address* argument identifies the IP address of the TFTP server on which your ARRIS® Gateway operating software is stored. The *filename* argument identifies the path and name of the operating software file on the TFTP server.

If you include the optional keyword *confirm*, you will not be prompted to confirm whether or not you want to perform the operation.

log message_string

Adds the message in the *message_string* argument to the ARRIS® Gateway diagnostic log.

loglevel [level]

Displays or modifies the types of log messages you want the ARRIS® Gateway to record. If you enter the **loglevel** command without the optional *level* argument, the command line interface displays the current log level setting.

You can enter the **loglevel** command with the *level* argument to specify the types of diagnostic messages you want to record. All messages with a level number equal to or greater than the level you specify are recorded. For example, if you specify loglevel 3, the diagnostic log will retain high-level informational messages (level 3), warnings (level 4), and failure messages (level 5).

Use the following values for the *level* argument:

- ◆ **1** or **low** – Low-level informational messages or greater; includes trivial status messages.
 - ◆ **2** or **medium** – Medium-level informational messages or greater; includes status messages that can help monitor network traffic.
 - ◆ **3** or **high** – High-level informational messages or greater; includes status messages that may be significant but do not constitute errors.
 - ◆ **4** or **warning** – Warnings or greater; includes recoverable error conditions and useful operator information.
 - ◆ **5** or **failure** – Failures; includes messages describing error conditions that may not be recoverable.
-

netstat -i

Displays the IP interfaces for your ARRIS® Gateway.

netstat -r

Displays the IP routes stored in your ARRIS® Gateway.

nslookup [hostname | ip_address]

Performs a domain name system lookup for a specified host.

- ◆ The *hostname* argument is the name of the host for which you want DNS information; for example, **nslookup klaatu**.
 - ◆ The *ip_address* argument is the IP address, in dotted decimal notation, of the device for which you want DNS information.
-

ping [-s size] [-c count] [hostname | ip_address]

Causes the ARRIS® Gateway to issue a series of ICMP Echo requests for the device with the specified name or IP address.

- ◆ The *hostname* argument is the name of the device you want to ping; for example, **ping ftp.mycompany.com**.
-

-
- ◆ The *ip_address* argument is the IP address, in dotted decimal notation, of the device you want to locate. If a host using the specified name or IP address is active, it returns one or more ICMP Echo replies, confirming that it is accessible from your network.
 - ◆ The **-s** *size* argument lets you specify the size of the ICMP packet.
 - ◆ The **-c** *count* argument lets you specify the number of ICMP packets generated for the ping request. Values greater than 250 are truncated to 250.

You can use the **ping** command to determine whether a hostname or IP address is already in use on your network. You cannot use the **ping** command to ping the ARRIS® Gateway's own IP address.

quit

Exits the ARRIS® Gateway command line interface.

6rd-check [-s *size*] [-c *count*] *conn_name*

Generates and sends 6rd loopback packets to the 6rd gateway.

reset arp

Clears the Address Resolution Protocol (ARP) cache on your unit.

reset crash

Clears crash-dump information, which identifies the contents of the ARRIS® Gateway registers at the point of system malfunction.

reset dhcp server

Clears the DHCP lease table in the ARRIS® Gateway.

reset enet [all]

Resets Ethernet statistics to zero. Resets individual LAN switch port statistics as well as Wi-Fi and WAN Ethernet statistics (where applicable).

reset firewall-log

Rewinds the firewall log to the first entry.

reset ipmap

Clears the IPMap table (NAT).

reset log

Rewinds the diagnostic log display to the top of the existing ARRIS® Gateway diagnostic log. The **reset** log command does not clear the diagnostic log. The next **show log** command will display information from the beginning of the log file.

reset wan

This function resets WAN interface statistics.

restart [seconds]

Restarts your ARRIS® Gateway. If you include the optional *seconds* argument, your ARRIS® Gateway will restart when the specified number of seconds have elapsed. You must enter the complete **restart** command to initiate a restart.

show all-info

Displays all settings currently configured in the ARRIS® Gateway.

show bridge interfaces

Displays bridge interfaces maintained by the ARRIS® Gateway.

show bridge table

Displays the bridging table maintained by the ARRIS® Gateway.

show config

Dumps the ARRIS Gateway's configuration script just as the **script** command does in config mode.

show crash

Displays the most recent crash information, if any, for your ARRIS® Gateway.

show dhcp server leases

Displays the DHCP leases stored in RAM by your ARRIS® Gateway.

show dhcp client

Displays the DHCP clients stored in RAM by your ARRIS® Gateway.

show f device-association

Displays LAN devices that conform with the TR111 Gateway requirement. It displays - IP Address, Manufacture OUI and Serial number.

show enet [all]

Displays Ethernet interface statistics maintained by the ARRIS® Gateway. Supports display of individual LAN switch port statistics as well as WAN Ethernet statistics (where applicable).

Example:

```
Ethernet driver full statistics - LAN
10/100/1000 Ethernet
Port Status: Link up

General:
  Transmit OK           : 253
  Receive OK            : 22
  Tx Errors              : 0
  Rx Errors              : 0

Receiver:
  Dropped Packets       : 0
```

```

Transmitter:
Collisions          : 0
Dropped Packet     : 0

Upper Layers:
Rx No Handler      : 0
Rx No Message      : 0
Rx Octets          : 4781
Rx Unicast Pkts   : 22
Rx Multicast Pkts : 0
Tx Discards       : 0
Tx Octets         : 17204

10/100/1000 Ethernet port 1
Port Status: Link down

10/100/1000 Ethernet port 2
Port Status: Link up
Duplex: Full
Speed: 1000BASE-T
Transmit OK        : 253
Transmit unicastpkts : 0
Tx Octets         : 16192
Tx Collision       : 0
Receive OK        : 24
Receive unicastpkts : 0
Receive errors    : 0
Rx Octets         : 4781

10/100/1000 Ethernet port 3
Port Status: Link down

10/100/1000 Ethernet port 4
Port Status: Link down

HPNA port 5 (counter values include management traffic)
Port Status: Link up
Duplex: Full
Speed: 200 MBPS
Transmit OK        : 1702
Transmit unicastpkts : 1173
Tx Octets         : 226117
Tx Collision       : 0
Receive OK        : 1168
Receive unicastpkts : 1168
Receive errors    : 0
Rx Octets         : 202156

Ethernet driver statistics - Wi-Fi
Port Status: Link down

Ethernet driver full statistics - PTM WAN
Port Status: Link down

Ethernet driver full statistics - WAN

10/100/1000 Ethernet
Port Status: Link down
Ethernet driver full statistics - 10/100 Ethernet
Port Status: Link up
Type: 100BASET Duplex: Full
General:
Transmit OK        : 434
Receive OK        : 267
Tx Errors          : 0
Rx Errors          : 0

Receiver:
Incompl Packet Errors : 0
No RBD's For Packet  : 0

```

```
Carrier Sense Lost      : 0
Deferred Replen        : 0

Transmitter:
TX Retries             : 0
Single Collisions      : 0
No Buf For Packet      : 0

Upper Layers:
Rx No Handler          : 0
Rx No Message          : 0
Rx Octets              : 30773
Rx Unicast Pkts        : 267
Rx Multicast Pkts      : 0
Tx Discards            : 0
Tx Octets              : 31692

10/100 Ethernet phy.enet.port

Port Status: Link up
Duplex: Full-duplex active
Speed: 100BASE-T
Transmit OK            : 434
Transmit unicastpkts  : NA
Receive OK             : 267
Receive unicastpkts   : 267
```

show enet tx-queue

```
"show enet tx-queue"

This is an output of what is should look like:

NOS/128600225699776/UNLOCKED> show enet tx-queue

No transmit software queue configured on Ethernet port 1
No transmit software queue configured on Ethernet port 2
No transmit software queue configured on Ethernet port 3
No transmit software queue configured on Ethernet port 4
No transmit software queue configured on Ethernet port 5
No transmit software queue configured on Ethernet port 6

Ethernet switch queue stats:
Port 1:
  TxQ1: 54257
  TxQ2: 0
  TxQ3: 0
  TxQ4: 508
Port 2:
  TxQ1: 55767
  TxQ2: 0
  TxQ3: 0
  TxQ4: 508
Port 3:
  TxQ1: 0
  TxQ2: 0
  TxQ3: 0
  TxQ4: 0
Port 4:
  TxQ1: 0
  TxQ2: 0
  TxQ3: 0
  TxQ4: 0
Port 5:
  TxQ1: 92950
  TxQ2: 0
  TxQ3: 0
  TxQ4: 508
```

show group-mgmt

Displays the IGMP Snooping Table. See [“IP IGMP commands” on page 140](#) for detailed explanation.

show ip arp

Displays the Ethernet address resolution table stored in your ARRIS® Gateway.

show ip igmp

Displays the contents of the IGMP Group Address table and the IGMP Report table maintained by your ARRIS® Gateway.

show ip interfaces

Displays the IP interfaces for your ARRIS® Gateway.

show ip firewall

Displays firewall statistics.

show ip lan-discovery

Displays the LAN Host Discovery Table of hosts on the wired or Wi-Fi LAN, and whether or not they are currently online.

show ip routes

Displays the IP routes stored in your ARRIS® Gateway.

show ipmap

Displays IPMap table (NAT).

show ipv6 interfaces

Display IPv6 interfaces.

show ipv6 routes

Display IPv6 route table.

show ipv6 neighbors

Display IPv6 neighbor table.

show ipv6 dhcp server leases

Display DHCPv6 server lease table.

show ipv6 statistics

Display IPv6 statistics information.

show log

Displays blocks of information from the ARRIS® Gateway diagnostic log. To see the entire log, you can repeat the **show log** command or you can enter **show log all**.

show firewall-log

Displays blocks of information from the ARRIS® Gateway firewall log.

show memory [all]

Displays memory usage information for your ARRIS® Gateway. If you include the optional **all** argument, your ARRIS® Gateway will display a more detailed set of memory statistics.

show ptm

Displays statistics information for each PTM session.

show post-results

Displays POST results.

show pppoe

Displays status information for each PPPoE socket, such as the socket state, service names, and host ID values.

show rootcert

Dumps the Subject line for the list of all the trusted root certificates for the 802.1x supplicant.

show rtsp

Displays RTSP ALG session activity data.

show status

Displays the current status of a ARRIS® Gateway, the device's hardware and software revision levels, a summary of errors encountered, and the length of time the ARRIS® Gateway has been running since it was last restarted. Identical to the **status** command.

show summary

Displays a summary of WAN, LAN, and Gateway information.

show vlan

Displays detail of VLAN status and statistics.

show Wi-Fi [all]

Shows Wi-Fi status and statistics.

show Wi-Fi clients [*MAC_address*]

Displays details on connected clients, or more details on a particular client if the MAC address is added as an argument.

show voip

Displays VoIP call statistics.

show voiplog

Displays VoIP event logs.

telnet [*hostname* | *ip_address*] [*port*]

Lets you open a telnet connection to the specified host through your ARRIS® Gateway.

- ◆ The *hostname* argument is the name of the device to which you want to connect; for example, **telnet ftp.mycompany.com**.
- ◆ The *ip_address* argument is the IP address, in dotted decimal notation, of the device to which you want to connect.
- ◆ The *port* argument is the number of the port over which you want to open a telnet session.

traceroute (*ip_address* | *hostname*)

Traces the routing path to an IP destination.

upload [*server_address*] [*filename*] [**confirm**]

Copies the current configuration settings of the Gateway to a TFTP (Trivial File Transfer Protocol) server. The TFTP server must be accessible on your Ethernet network. The *server_address* argument identifies the IP address of the TFTP server on which you want to store the ARRIS® Gateway settings. The *filename* argument identifies the path and name of the configuration file on the TFTP server. If you include the optional **confirm** keyword, you will not be prompted to confirm whether or not you want to perform the operation.

view config

Dumps the ARRIS Gateway's configuration just as the **view** command does in config mode.

who

Displays the names of the current shell and PPP users.

wps

Enters the Wi-Fi (Wi-Fi) Protected Setup mode.

WPS Commands

The following commands are available in Wi-Fi protected setup:

pushbutton

Sets the ARRIS® Gateway to WPS "pushbutton" mode, initiating protected setup.

pin

Sets the ARRIS® Gateway to PIN mode, enabling authorized devices to be identified and added by MAC address Personal Identification Number.

list

Lists the WPS-ready client devices (enrollees) known to the ARRIS® Gateway.

self-pin

Displays the ARRIS® Gateway's own Personal Identification Number (PIN) value.

WAN Commands

show enet

Displays statistics for both the WAN and the Wireless.

show enet all

Displays statistics for the WAN, LAN and Wireless.

show enet tx-queue

Displays all tx-queues configured on the device. `show ppp [{ stats | lcp | ipcp }]`

show opticwan data

Displays information for the Fiber WAN.

Show voip all

Displays information for all the phone lines, including "test lines".

About CONFIG Commands

You reach the configuration mode of the command line interface by typing **configure** (or any truncation of **configure**, such as **con** or **config**) at the CLI SHELL prompt.

CONFIG Mode Prompt

When you are in CONFIG mode, the CLI prompt consists of the name of the ARRIS® Gateway followed by your current **node** in the hierarchy and two right angle brackets (>>). For example, when you enter CONFIG mode (by typing **config** at the SHELL prompt), the **ARRIS-3000/9437188 (top)>>** prompt reminds you that you are at the top of the CONFIG hierarchy. If you move to the **ip** node in the CONFIG hierarchy (by typing **ip** at the CONFIG prompt), the prompt changes to **ARRIS-3000/9437188 (ip)>>** to identify your current location.

Some CLI commands are not available until certain conditions are met. For example, you must enable IP for an interface before you can enter IP settings for that interface.

Navigating the CONFIG Hierarchy

- ◆ **Moving from CONFIG to SHELL** — You can navigate from anywhere in the CONFIG hierarchy back to the SHELL level by entering **quit** at the CONFIG prompt and pressing Return.

```
ARRIS-3000/9437188 (top)>> quit
ARRIS-3000/9437188 >
```

- ◆ **Moving from top to a subnode** — You can navigate from the top node to a subnode by entering the node name (or the significant letters of the node name) at the CONFIG prompt and pressing RETURN. For example, you move to the IP subnode by entering **ip** and pressing RETURN.

```
ARRIS-3000/9437188 (top)>> ip
ARRIS-3000/9437188 (ip)>>
```

As a shortcut, you can enter the significant letters of the node name in place of the full node name at the CONFIG prompt. The significant characters of a node name are the letters that uniquely identify the node. For example, since no other CONFIG node starts with **b**, you could enter one letter ("**b**") to move to the bridge node.

- ◆ **Jumping down several nodes at once** — You can jump down several levels in the CONFIG hierarchy by entering the complete path to a node.
- ◆ **Moving up one node** — You can move up through the CONFIG hierarchy one node at a time by entering the **up** command.
- ◆ **Jumping to the top node** — You can jump to the top level from anywhere in the CONFIG hierarchy by entering the **top** command.
- ◆ **Moving from one subnode to another** — You can move from one subnode to another by entering a partial path that identifies how far back to climb.
- ◆ **Moving from any subnode to any other subnode** — You can move from any subnode to any other subnode by entering a partial path that starts with a top-level CONFIG command.
- ◆ **Scrolling backward and forward through recent commands** — You can use the Up and Down arrow keys to scroll backward and forward through recent commands you have entered. When the command you want appears, press Enter to execute it.

Entering Commands in CONFIG Mode

CONFIG commands consist of keywords and arguments. Keywords in a CONFIG command specify the action you want to take or the entity on which you want to act. Arguments in a CONFIG command specify the values appropriate to your site. For example, the CONFIG command

set ip dns domain-name *domain_name_value*

consists of three keywords (*ip*, *dns* and *domain-name*) and one argument (*domain_name_value*). When you use the command to configure your Gateway, you would replace the argument with a value appropriate to your site.

For example:

```
set ip dns domain-name ARRIS.com
```

Guidelines: CONFIG Commands

The following table provides guidelines for entering and formatting CONFIG commands.

Command component	Rules for entering CONFIG commands
Command verbs	CONFIG commands must start with a command verb (set, view, delete). You can truncate CONFIG verbs to three characters (set, vie, del). CONFIG verbs are case-insensitive. You can enter "SET," "Set," or "set."
Keywords	Keywords are case-insensitive. You can enter "Ethernet," "ETHERNET," or "ethernet" as a keyword without changing its meaning. Keywords can be abbreviated to the length that they are differentiated from other keywords.
Argument Text	Text strings can be as many as 64 characters long, unless otherwise specified. In some cases they may be as long as 255 bytes. Special characters are represented using backslash notation. Text strings may be enclosed in double (") or single (') quote marks. If the text string includes an embedded space, it must be enclosed in quotes. Special characters are represented using backslash notation.
Numbers	Enter numbers as integers, or in hexadecimal, where so noted.
IP addresses	Enter IP addresses in dotted decimal notation (0 to 255).

If a command is ambiguous or miskeyed, the CLI prompts you to enter additional information. For example, you must specify which virtual circuit you are configuring when you are setting up a ARRIS® Gateway.

Displaying Current Gateway Settings

You can use the *view* command to display the current CONFIG settings for your ARRIS® Gateway. If you enter the *view* command at the top level of the CONFIG hierarchy, the CLI displays the settings for all enabled functions. If you enter the *view* command at an intermediate node, you see settings for that node and its sub-nodes.

Step Mode: A CLI Configuration Technique

The ARRIS® Gateway command line interface includes a step mode to automate the process of entering configuration settings. When you use the CONFIG step mode, the command line interface prompts you for all required and optional information. You can then enter the configuration values appropriate for your site without having to enter complete CLI commands.

When you are in step mode, the command line interface prompts you to enter required and optional settings. If a setting has a default value or a current setting, the command line interface displays the default value for the command in parentheses. If a command has a limited number of acceptable values, those values are presented in brackets, with each value separated by a vertical line.

For example, the following CLI step command indicates that the default value is **off** and that valid entries are limited to **on** and **off**.

```
option (off) [on | off]: on
```

You can accept the default value for a field by pressing the Return key. To use a different value, enter it and press Return.

You can enter the CONFIG step mode by entering **set** from the top node of the CONFIG hierarchy. You can enter step mode for a particular service by entering **set service_name**. In stepping set mode (press Control-X <Return/Enter> to exit. For example:

```
ARRIS-3000/9437188 (top)>> set system
...
system
  name ("ARRIS-3000/9437188"): Mycroft
  Diagnostic Level (High): medium
Stepping mode ended.
```

Validating Your Configuration

You can use the **validate** CONFIG command to make sure that your configuration settings have been entered correctly. If you use the **validate** command, the ARRIS® Gateway verifies that all required settings for all services are present and that settings are consistent.

```
ARRIS-3000/9437188 (top)>> validate
Error: Subnet mask is incorrect
Global Validation did not pass inspection!
```

You can use the **validate** command to verify your configuration settings at any time. Your ARRIS® Gateway automatically validates your configuration any time you save a modified configuration.

CONFIG Commands

This section describes the keywords and arguments for the various CONFIG commands.

Connection commands

conns are used to create connections, for example, a WAN or LAN **conn**. There may be more than one of each depending on your model. **names** correspond to the system object IDs (OIDs) but you can name them yourself.

set conn name *name* link-oid *value*

Sets the connection named *name* to point to an associated link specified by the **link-oid** value.

set conn name *name* type [static | dhcpc | ppp]

Specifies whether the **type** of the connection named *name* is static, dhcpc, or ppp.

set conn name *name* side [lan | wan]

Specifies whether this conn is LAN- or WAN-side. A **conn** can be either **lan** or **wan**.

set conn name *name* lan-type [private | public | public-delegated]

Specifies whether this conn's LAN is private, public, or public-delegated. The default is **private**, the usual type of local network.

set conn name *name* dhcp-server-enable [on | off]

Turns the DHCP server for this connection **on** or **off**. The DHCP server can be enabled per connection. The default is **on**.

set conn name *name* mcast-forwarding [off | on]

Turns IP IGMP multicast forwarding for this connection **off** or **on**. The default is **off**.

set conn name *name* rip-send [off | v1 | v2 | v1-compatible | v2-md5]

Specifies whether the device should use Routing Information Protocol (RIP) broadcasts to advertise its routing tables to other Gateways. RIP Version 2 (RIP-2) is an extension of the original Routing Information Protocol (RIP-1) that expands the amount of useful information in the RIP packets. While RIP-1 and RIP-2 share the same basic algorithms, RIP-2 supports several additional features, including inclusion of subnet masks in RIP packets and implementation of multicasting instead of broadcasting (which reduces the load on hosts which do not support routing protocols. RIP-2 with MD5 authentication is an extension of RIP-2 that increases security by requiring an authentication key when routes are advertised. Depending on your network needs, you can configure your device to support RIP-1, RIP-2, or RIP-2MD5.

If you specify v2-MD5, you must also specify a rip-send-key. Keys are ASCII strings with a maximum of 31 characters, and must match the other Gateway(s) keys for proper operation of MD5 support. The default is **off**.

set conn name *name* rip-receive [off | v1 | v2 | v1-compatible | v2-md5]

Specifies whether the device should use Routing Information Protocol (RIP) broadcasts to update its routing tables with information received from other Gateways on the other side of the connection. If you specify **v2-md5**, you must also specify a rip-receive-key. Keys are ASCII strings with a maximum of 31 characters, and must match the other Gateway(s) keys for proper operation of MD5 support. The default is **off**.

set conn name *name* icmp-echo-drop [off | on]

If set to **on**, drops echo-requests received on the particular interface. The default is **off**.

set conn name *name* icmp-err-suppress [off | on]

An additional option to suppress ICMP error messages on WAN IP interfaces. The default is **off**.

set conn name *name* static ipaddr *ipaddr*

Specifies a **static** IP address when the connection **type** has been set to **static**. The default is 192.168.1.254.



NOTE:

You must also set the gateway address OR turn it off, otherwise the settings cannot be saved. See [“IP Gateway commands” on page 133](#).

Example:

```
NOS/128600225634272/conf
Config Mode v1.3
NOS/128600225634272 (top)>> conn
NOS/128600225634272 (conn)>> set
  conn
(conn) node list ...
  "LAN"
  "WAN"
Select (name) node to modify from list,
or enter new (name) to create.
  conn name (?):
    name "LAN"
      link-oid ("LAN") [ LAN | WAN | PPPoE | ]:
      type (static) [ static | dhcpc | ppp ]:
      side (lan) [ lan | wan ]:
      lan-type (private) [ private | public | public-delegated ]:
      mcast-forwarding (off) [ off | on ]:
      rip-send (off) [ off | v1 | v2 | v1-compatible | v2-md5 ]:
      rip-receive (off) [ off | v1 | v2 | v1-compatible | v2-md5 ]:
      fs-egress ("") [ Security | QosUpstream | WanEgress | ]:
      fs-ingress ("") [ Security | QosUpstream | WanEgress | ]:
      static
        ipaddr ("192.168.1.254"):
        netmask ("255.255.255.0"):
        dhcp-server-enable (on) [ off | on ]:
        dhcp-server
          start-addr ("192.168.1.64"):
          end-addr ("192.168.7.253"):
          lease-time (01:00:00:00):
          subnet-order (1) [ 1 - 8 ]:
          gen-option
            (gen-option) node list ...
            Select (name) node to modify from list,
            or enter new (name) to create.
              gen-option name (?):
                option-group
            (option-group) node list ...
            Select (name) node to modify from list,
            or enter new (name) to create.
              option-group name (?):
                filterset
            (filterset) node list ...
            Select (name) node to modify from list,
            or enter new (name) to create.
              filterset name (?):
                name "WAN"
                  link-oid ("WAN") [ LAN | WAN | PPPoE | ]:
                  type (dhcpc) [ static | dhcpc | ppp ]: static
                  side (wan) [ lan | wan ]:
                  mcast-forwarding (off) [ off | on ]:
                  nat-enable (on) [ off | on ]:
                  rip-receive (off) [ off | v1 | v2 | v1-compatible | v2-md5 ]:
```

```
icmp-echo-drop (on) [ off | on ]:  
icmp-err-suppress (off) [ off | on ]:  
fs-egress ("WanEgress") [ Security | QosUpstream | WanEgress | ]:  
fs-ingress ("") [ Security | QosUpstream | WanEgress | ]:  
static  
  ipaddr (""): 10.3.53.100  
  netmask ("255.255.255.0"):  
NOS/128600225634272 (conn)>> set ip gateway address 10.3.53.1  
NOS/128600225634272 (conn)>> save  
If you do not want the gateway use this command to turn it off:  
set ip gateway enable off
```

set conn name *name* static netmask *netmask*

Specifies a **static** netmask when the connection **type** has been set to **static**. The default is 255.255.255.0.

set conn name *name* dhcp-server start-addr *ipaddr*

If **dhcp-server-enable** is set to **on**, specifies the first address in the DHCP address range. The ARRIS® Gateway can reserve a sequence of up to 253 IP addresses within a subnet, beginning with the specified address for dynamic assignment. The default is 192.168.1.64

set conn name *name* dhcp-server end-addr *ipaddr*

If **dhcp-server-enable** is set to **on**, specifies the last address in the DHCP address range. The default is 192.168.7.253

set conn name *name* dhcp-server lease-time *seconds*

If **dhcp-server-enable** is set to **on**, specifies the default length for DHCP leases issued by the ARRIS® Gateway. Lease time is in seconds. Default is **3600**.

set conn name *name* dhcp-server subnet-order [1... 8]

If **dhcp-server-enable** is set to **on**, specifies the order in which to address the first of 8 possible subnets. Ordinarily, this is the first one, the default **1**.

set conn name *name* nat-enable [on | off]

Specifies whether you want the ARRIS Gateway to use network address translation (NAT) when communicating with remote Gateways. NAT lets you conceal details of your network from remote Gateways. It also permits all LAN devices to share a single IP address. By default, address NAT is turned **on**.

set conn name *name* dhcp-client discover-time *seconds*

The DHCP client parameters appear when the connection **type** has been set to **dhcpc**. **discover-time** is in seconds; the default is **30**.

set conn name *name* dhcp-client dns-enable [on | off]

This allows you to enable or disable the default behavior of acting as a DNS proxy. The default is **on**.

set conn name *name* dhcp-client dns-override [off | on]

This allows you to enable or disable overriding default DNS behavior. The default is **off**.

set conn name *name* **dhcp-client vendor-class** *string*

The **vendor-class** default information varies by model and components. This is information that identifies the unit.

set conn name *name* **fs-egress** *filterset_name*

Attaches a user filterset to a conn which is applied to transmitted packets. See [“Filterset commands” on page 126](#).

set conn name *name* **fs-ingress** *filterset_name*

Attaches a user filterset to a conn which is applied to received packets. See [“Filterset commands” on page 126](#).

Filterset commands

Filtersets provide packet filtering and QoS configuration. Packets are identified by characteristics that allow QoS and forwarding decisions to be made. These characteristics can be at the MAC layer, IP layer, TCP | UDP | ICMP layer(s), or (in applicable circumstances) 802.1q/p (VLAN-tagging) layer.

Your Gateway is capable of adding and stripping 802.1Q tags to and from frames before transmission on its LAN interfaces. See also ["Link commands" on page 144](#) for more information.

A maximum of 8 filtersets are supported. Each filterset can have up to 8 rules configured. A maximum 8 egress queues are supported. Each queue can have up to 8 entries.

A filterset rule identifies packet attributes to match with its **match** parameters. It acts on these packets using its **default action** parameters.

set filterset name *filterset_name* **rule** *number* **order** *number*

Determines order of execution of filterset rules (1 before 2, etc). If **order** is unspecified, the value of **order** is set to 1 more than the last order in the filterset. If **order** is set to an already existing order value, order values of other rules are incremented automatically.

set filterset name *filterset_name* **rule** *number* **enable** [**on** | **off**]

Dynamically enables or disables the specified filterset rule.

set filterset name *filterset_name* **rule** *number* **match-eth-proto** *number*

Matches ethernet protocol field to the supplied value.

set filterset name *filterset_name* **rule** *number* **match-eth-length** *number*

Matches ethernet length field to the supplied value.

set filterset name *filterset_name* **rule** *number* **match-eth-p-bits** *number*

Matches VLAN priority bits.

set filterset name *filterset_name* **rule** *number* **match-eth-vid** *number*

Matches VLAN id number.

set filterset name *filterset_name* **rule** *number* **match-eth-src-mac-addr** *mac_address*

Matches supplied source MAC address field.

set filterset name *filterset_name* **rule** *number* **match-eth-dst-mac-addr** *mac_address*

Matches supplied destination MAC address field.

set filterset name *filterset_name* **rule** *number* **match-src-ip-addr** *ip_address_range*

Matches supplied value with packet's source ip address field.

set filterset name *filterset_name* **rule** *number* **match-dst-ip-addr** *ip_address_range*

Matches supplied value with packet's destination ip address field.

set filterset name *filterset_name* **rule number** **match-protocol** *protocol_string*

Matches supplied value with packet's protocol field.

set filterset name *filterset_name* **rule number** **match-tos** [*number* | *descriptive_value*]

Matches tos field from numeric value 0-255; or one of the following descriptive values:

- Minimize-Delay (0x10)
- Maximize-Throughput (0x08)
- Maximize-Reliability (0x04)
- Minimize-Cost (0x02)
- Normal-Service (0x00)

set filterset name *filterset_name* **rule number** **match-dscp** [*number* | *diffserv_class_string*]

Matches diffserv class with supplied numerical value, which can be in decimal(ex: 32) or in Hex(ex: 0x20);

Or match the supplied diffserv class. This value may be any of the BE, EF, AFxx or CSx classes. A full list is:

- { "CS0", 0x00 }
- { "CS1", 0x08 }
- { "CS2", 0x10 }
- { "CS3", 0x18 }
- { "CS4", 0x20 }
- { "CS5", 0x28 }
- { "CS6", 0x30 }
- { "CS7", 0x38 }
- { "BE", 0x00 }
- { "AF11", 0x0a }
- { "AF12", 0x0c }
- { "AF13", 0x0e }
- { "AF21", 0x12 }
- { "AF22", 0x14 }
- { "AF23", 0x16 }
- { "AF31", 0x1a }
- { "AF32", 0x1c }
- { "AF33", 0x1e }
- { "AF41", 0x22 }
- { "AF42", 0x24 }
- { "AF43", 0x26 }
- { "EF", 0x2e }

set filterset name *filterset_name* **rule number** **match-src-port** *number* [*number*]

Matches TCP|UDP source port field or port range.

set filterset name *filterset_name* **rule number** **match-dst-port** *number* [*number*]

Matches TCP|UDP destination port field or port range.

set filterset name *filterset_name* **rule number** **match-tcp-flags** *tcp_flag_string*

Matches TCP flags in a packet. The flag string is comma-delimited.

set filterset name *filterset_name* **rule** *number* **match-packet-length** *number* [*number*]

Matches packet length against value or range.

set filterset name *filterset_name* **rule** *number* **action forward** [**pass** | **drop** | **reject**]

Executes the named filterset's default action: **pass**, **drop**, or **reject**.

set filterset name *filterset_name* **rule** *number* **match-qos-marker-enable** [**off** | **on**]

Turns the function of tagging the packet according to the queue marker name on or off. Default is **off**.

set filterset name *filterset_name* **rule** *number* **action set-qos-marker** *qos_marker_string*

Tags the packet according to the queue marker name. See ["Queue commands" on page 130](#).

set filterset name *filterset_name* **rule** *number* **action set-tos** *number*

Sets the packet tos field to the supplied value.

set filterset name *filterset_name* **rule** *number* **action set-dscp** [*number* | *diffserv_class_string*]

Sets the dscp field to the supplied value.

set filterset name *filterset_name* **rule** *number* **action set-eth-p-bits** *number*

Sets vlan priority bits to the supplied value.

set filterset *filterset_name* **rule** *number* **action do-filterset** *name*

Executes the supplied filterset.

Default actions

If a packet passes through all of a filter's rules without a match, then the filterset's default-actions come into play. These behave the same way that rule actions behave.

set filterset name *filterset_name* **default-action set-qos-marker** *qos_marker_string*

Tags the packet according to the queue marker name.

set filterset name *filterset_name* **default-action set-tos** *number*

Sets the packet tos field to the supplied value.

set filterset name *filterset_name* **default-action set-dscp** [*number* | *diffserv_class_string*]

Sets the dscp field to the supplied value.

set filterset name *filterset_name* **default-action set-eth-p-bits** *number*

Sets vlan priority bits to the supplied value.

set filterset name *filterset_name* default-action do-filterset *name*

Executes the supplied filterset.

set filterset name *filterset_name* default-action forward [pass | drop | reject]

Executes the named filterset's default action: **pass**, **drop**, or **reject**.

Global Filterset (“IPv6 Firewall”) commands

Global filtersets exist at the root level of the hierarchy, outside the umbrella of both the “ip” and “ip6” subtrees, since they pertain to both.

Global filterset rules allow for the specification of these match attributes:

- ◆ IP Protocol
- ◆ Source and/or Destination Port
 - UDP
 - TCP
- ◆ TCP flags, for rules that specify TCP traffic
- ◆ ICMP Type, for IP-protocol types 1 (ICMP) and 58 (IPv6-ICMP)
- ◆ LAN-side device/range
 - By MAC address (or current IPv4/6 address, host name, equivalently)
 - IPv4 address, range, or subnet
 - IPv6 address or subnet
- ◆ WAN-side range
 - IPv4 address, range, or subnet
 - IPv6 address or subnet
- ◆ Ingress and egress interface, by link-oid (e.g. “LAN”)

set gfs name *filterset_name* enable [on | off]

Dynamically enables or disables the specified filterset rule.

set gfs name *filterset_name* default-action value [pass | drop]

Executes the named filterset's default action: **pass**, or **drop**.

set gfs name *filterset_name* rule *number* enable [on | off]

Dynamically enables or disables the specified filterset rule.

set gfs name *filterset_name* rule *number* active [on | off]

Activates or deactivates the specified filterset rule.

set gfs name *filterset_name* rule *number* type [either | ipv4 | ipv6]

Specifies whether the named filterset rule applies to IPv4, IPv6, or both (either).

set gfs name *filterset_name* rule *number* action value [pass | drop | accept]

Executes the named filterset's action: **pass**, **drop**, or **accept**.

set gfs name *filterset_name* rule *number* order *number*

Determines order of execution of filterset rules (1 before 2, etc). If **order** is unspecified, the value of **order** is set to 1 more than the last order in the filterset. If **order** is set to an already existing order value, order values of other rules are incremented automatically.

set gfs name *filterset_name* rule *number* match *number* category [*src-ip-addr* | *dst-ip-addr* | *ip-proto* | *src-port* | *dst-port* | *tcp-flags* | *src-host-mac* | *dst-host-mac* | *in-link-oid* | *out-link-oid* | *icmp-type*]

Matches on the following categories:

src-ip-addr	(ip[4 6] address or subnet spec (type ip4 or ip6 only))
dst-ip-addr	(ip[4 6] address or subnet spec (type ip4 or ip6 only))
ip-proto	(0-255 or iana-defined string equivalents)
src-port	(1-65535[:1-65535], only if ip-proto == TCP or UDP)
dst-port	(1-65535[:1-65535], only if ip-proto == TCP or UDP)
tcp-flags	(only if ip-proto == TCP)
icmp-type	(only if ip-proto == ICMP or IPv6 ICMP)
src-host-mac	(MAC address of src)
dst-host-mac	(MAC address of dest)
in-link-oid	(oid of ingress link oid)
out-link-oid	(oid of egress link oid)

set gfs name *filterset_name* rule *number* match *number* value [*value* (category-specific)]
**NOTE:**

A rule cannot contain data that specifies both IPv6 and IPv4 at the same time, and thus be applicable to neither iptables nor ip6tables; however, a rule can be IP-version-agnostic, in which case it will be applied to both iptables and ip6tables, given the proper conditions. For instance, if a LAN-side device has both an IPv4 address and a routable IPv6 address, then one can specify a rule for this device by referring to its MAC address, and if no other match attributes of the rule preclude its use in both tables, the rule will be applied to both iptables and ip6tables (given the assumption that the LAN Host Discovery database contains both addresses).

Queue commands

Queue configuration typically requires a classification component to set a QoS marker to a packet and a queuing component to schedule the marked packets to the link. This is accomplished using filtersets ([“Filterset commands” on page 126](#)).

The **basic queue**'s **size** and “length” are controls for how many packets and total bytes can be enqueued before it is considered to be full. Once it is full, any attempts to enqueue another packet will result in a “tail-drop.”

Both constraints are simultaneously used, such that it is full when either packet count OR byte count exceeds the limit. This allows flexibility in obtaining a balance, where a large number of small packets, but only a small number of large packets can be enqueued.

If there are no tail-drops – that is, the queue is not blocked from sending and doesn't over-fill and dump packets – then these queue size/bytes parameters do not affect anything. Their only function is to adjust the threshold at which the queue is considered full, which dictates when tail drops will occur. So if there are no

tail-drops, then increasing the queue length will have no effect. Increasing the queue length has no effect unless there are tail-drops.

The maximum size/bytes of a queue balances how much burstiness can be buffered versus having a queue that is simply too long.

Burstiness smoothing requires queueing up the buffers. For example, if the upstream line rate is 1mbps, but the traffic source sends 100mbps bursts for 10ms every second (which coincidentally averages 1mbps) then the router will have to buffer enough (about a full second worth of traffic) so that the burst of traffic doesn't get tail-dropped when it arrives and is enqueued at the same time in the same burst.

On the other hand, it is undesirable to buffer too much data in the queue(s) since the packets may be stale by the time they are sent. It may be desirable to drop the traffic sufficiently that there are queuing disciplines such as Random Early Discard (**red**) that don't drop from the tail of the queue. Instead, **red** drops packets towards the front of the queue, so that the congestion is noticed more quickly in order for the sender to scale back bandwidth usage to avoid drops.

the following types of queue "building blocks" are supported:

- ◆ **basic** queue
- ◆ **ingress** queue
- ◆ **priority** queue
- ◆ **wfq** (weighted fair queue)

Basic queues have three different packet dropping options

- ◆ byte|packet fifo (bpfifo)
- ◆ random early discard (**red**)
- ◆ stochastic fairness queuing (**sfq**)

set queue name *queue_name* type [basic | ingress | priority | wfq]

Sets the type of queue.

set queue name *queue_name* options [off | red | sfq]

Sets the queue packet dropping options.

set queue name *queue_name* size [1... 64]

Sets the maximum number of packets that can be enqueued.

set queue name *queue_name* bytes [2048... 131072]

Sets the maximum total number of bytes that can be enqueued.

set queue name *queue_name* perturb [0... 100]

Sets the interval in seconds for queue algorithm perturbation when queue option is **sfq**.

set queue name *queue_name* police-rate [0... 10000000]

Sets the rate in milliseconds that is used for policing traffic when the queue type is **ingress**.

set queue name *queue_name* police-burst [0... 10000000]

Sets the burst rate in milliseconds that is used for policing traffic when the queue type is **ingress**.

set queue name *queue_name* bw-sharing [on | off]

Enables or disables bandwidth sharing, when the queue type is either **priority** or **wfq**.

set queue name *queue_name* bps-mode [bps | relative]

Sets the mode of the weighted fair queue. **bps** indicates that weights are defined as “bits-per-second”. **relative** indicates that weights are defined as a proportion of the sum of the weights of all inputs to the **wfq**.

set queue name *queue_name* entry number input *queue_name*

Sets the input to a priority or weighted fair queue.

set queue name *queue_name* entry number marker *queue_marker*

Sets the marker with which packets must be marked to be directed to this queue entry's input queue when the type is **priority** or **wfq**.

set queue name *queue_name* entry number priority [0... 255]

Sets the priority level of this queue. A lower value indicates a higher priority. All entries of equal priority will be subject to a round robin algorithm.

- ◆ for (strict) **priority** queue, the higher priority gets link resource first.
 - ◆ for **wfq** queue, each entry gets reserved bandwidth according to its weight. If different priority is given, any excess bandwidth is offered to higher priority entry first; otherwise any excess bandwidth is distributed to the weights ratio.
-

set queue name *queue_name* entry number weight [0... 100]

Sets the weight level of this weighted fair queue. Weight units are dependent on **bps-mode** setting.

- ◆ If **bps-mode** is set to **bps**, then setting the weight to 0 will allocate the remaining available bandwidth to the queue entry.
 - ◆ If no priority specified, excess bandwidth will be distributed proportionately to the weight ratio.
-

set queue name *queue_name* entry number peak [0... 100,000,000]

Sets the peak level of this weighted fair queue. The **peak** parameter is a number of 0 through 100,000,000 in bits/second. It must be at least 50,000 for best effect. It is the peak data rate allowed on the queue entry, and usually supports bandwidth sharing, that is, if other queues are not busy and there is spare bandwidth, then a busy queue is allowed to go up to the peak rate.

set queue name *queue_name* default-entry *queue_name*

Indicates the input queue which is used if there is no match between the packet queue marker and the configured markers in any of the queue's inputs when the queue type is **priority** or **wfq**.

IP Gateway commands

set ip gateway enable [on | off]

Specifies the **conn** of the gateway. Normally, this would be the WAN connection. Specifies whether the ARRIS® Gateway should send packets to a default Gateway if it does not know how to reach the destination host.

set ip gateway conn-oid *value*

Sets the default Gateway to point to an associated link specified by the **conn-oid** value.

set ip gateway address *ip_address*

Specifies the IP address of a host on a local or remote network in standard dotted-quad format.

IPv6 Commands

set ip6 enable [on | off]

Enables/disables IPv6 globally. The default is **off**. When enabled, the following default configuration is created:

```
set ip6 enable on
set ip6 conn name "WANv6" enable on
set ip6 conn name "WANv6" type rd
set ip6 conn name "WANv6" mtu 1472
set ip6 conn name "WANv6" side wan
set ip6 conn name "WANv6" mcast-forwarding off
set ip6 conn name "WANv6" icmp-echo-drop on
set ip6 conn name "WANv6" traffic-class-clear on
set ip6 conn name "WANv6" 6rd-tunnel type cpe
set ip6 conn name "WANv6" 6rd-tunnel ipv4-conn "WAN"
set ip6 conn name "WANv6" 6rd-tunnel use-dhcp-values off
set ip6 conn name "WANv6" 6rd-tunnel prefix "::"
set ip6 conn name "WANv6" 6rd-tunnel prefix-length 1
set ip6 conn name "WANv6" 6rd-tunnel ipv4-common-bits 0
set ip6 conn name "WANv6" 6rd-tunnel relay-ipv4-addr "0.0.0.0"
set ip6 conn name "WANv6" 6rd-tunnel ipv4-tx-tos-mode off
set ip6 conn name "WANv6" 6rd-tunnel force-tx-to-br on
set ip6 conn name "WANv6" 6rd-tunnel anti-spoof-enable on
set ip6 conn name "WANv6" 6rd-tunnel tx-df-bit-set on
set ip6 conn name "LANv6" enable off
set ip6 gateway enable on
set ip6 gateway conn "WANv6"
set ip6 gateway address "::"
set ip6 dhcp-server enable on
set ip6 dhcp-server information-only off
set ip6 dhcp-server preference 255
set ip6 dhcp-server authoritative on
set ip6 dhcp-server rapid-commit on
set ip6 dhcp-server unicast off
set ip6 dhcp-server leasequery off
set ip6 dhcp-server pd-enable on
set ip6 dhcp-server default-lease-time 2592000
set ip6 dhcp-server preferred-lifetime 604800
set ip6 dhcp-server T1 302400
set ip6 dhcp-server T2 483840
set ip6 dhcp-server info-refresh-time 86400
set ip6 dns primary-address ""
set ip6 dns secondary-address ""
```

Default IPv6 security configuration values:

```
set security spi ip6 src-mcast-drop off
set security spi ip6 invalid-mcast-scope-drop on
set security spi ip6 forbidden-addr-drop on
set security spi ip6 deprecated-ext-hdr-drop on
set security spi ip6 src-addr-from-lan-unassigned-drop on
set security spi ip6 lan-assigned-src-addr-from-wan-drop on
set security spi ip6 ula-drop on
```

```
set security spi ip6 ignore-dns-from-wan on
set security spi ip6 ignore-dhcp-from-wan on
set security spi ip6 esp-hdr-drop on
set security spi ip6 ah-hdr-drop on
set security spi ip6 allow-inbound off
set security spi ip4 invalid-addr-drop on
set security spi ip4 private-addr-drop off
set security spi flood-limit enable off
set security ip6 firewall-level low
set security ip6 enable on
```

ip6 gateway conn

set ip6 gateway enable [on | off]

Enables or disables IPv6 default gateway.

set ip6 gateway conn *value*

Sets the default Gateway to point to an associated link specified by the **conn-oid** value. Normally, this would be the WAN connection.

set ip6 gateway address *ipv6_address*

Specifies the IPv6 address of a host on a local or remote network in standard IPv6 format.

ip6 conn

set ip6 conn name *name* enable [on | off]

Enables/disables the IPv6 connection named *name*.

set ip6 conn name *name* type [static | autoconf | rd | dp | aiccu]

Type of connection. See below for connection types.

set ip6 conn name *name* mtu *octets*

Specified MTU of connection.

set ip6 conn name *name* side [lan | wan]

Specified whether the connection is LAN side or WAN side.

set ip6 conn name *name* mcast-fwding [off | on]

Turns IPv6 multicast forwarding for this connection off or on. The default is **off**. (not yet implemented)

set ip6 conn name *name* old-prefix-purge-timer

The time in seconds for which old, invalid prefixes are advertised with a lifetime of zero. The intent is to “flush out” global prefixes on attached IPv6 hosts which suddenly become invalid.

Static Connections

ip6 conn (type = static): Statically configured IPv6 connection.

set ip6 conn name *name* static link-oid *link_name*

Sets the connection named *name* to point to an associated link specified by the link-oid *link_name*.

set ip6 conn name *name* static ipaddr *ipv6_address*

Specifies a static IPv6 address.

set ip6 conn name *name* static prefix-length *value*

Specifies the prefix length of the connection's static IPv6 address. Default is **64**.

6rd Connections

ip6 conn (type = rd, side = wan). This WAN connection type is a 6rd tunnel over an IPv4 conn in accordance with RFC 5569.

set ip6 conn name *name* 6rd-tunnel type [*cpe* | *gateway*]

The 6rd connection can operate in “*cpe*” or “*gateway*” mode as configured by the type parameter. “*cpe*” mode is used when operating as a CPE; “*gateway*” mode is used when operating as a “6rd relay” as per RFC 5569.

set ip6 conn name *name* 6rd-tunnel ipv4-conn-oid *ipv4_name*

Sets the 6rd connection named *name* to tunnel over an associated IPv4 connection named *ipv4_name*.

set ip6 conn name *name* 6rd-tunnel use-dhcp-values [*off* | *on*]

If this parameter is on, 6rd-provisioned parameters are obtained via the underlying DHCPv4 client associated with IPv4 connection named *ipv4-name*. See “draft-ietf-softwire-ipv6-6rd-10” for DHCP format description.

ip6 conn (type = rd, 6rd-tunnel use-dhcp-values = off).

set ip6 conn name *name* 6rd-tunnel prefix *IPv6_address*

6rd domain prefix.

set ip6 conn name *name* 6rd-tunnel prefix-length *value* [**1 - 63]**

6rd domain prefix length.

set ip6 conn name *name* 6rd-tunnel ipv4-common-bits *value* [**0 - 31]**

The number of bits common to all IPv4 addresses within the 6rd domain. The top-most bits of the IPv4 address will be “subtracted” from the 6rd address. If the whole 32-bit IPv4 address is contained in the 6rd IPv6 address, this value is set to zero. Default is 0, meaning all 42 bits of the IPv4 address are embedded in the 6rd prefix.

set ip6 conn name *name* 6rd-tunnel relay-ipv4-addr *IPv4_address*

The IPv4 anycast address of the 6rd border gateway.

set ip6 conn name *name* 6rd-tunnel ipv4-tx-tos-mode [off | use-ipv6]

off means the TOS field in the IPv4 header is set to zero for transmitted 6rd packets. **use-ipv6** means the the TOS field in the IPv4 header is set to the DS field of the 6rd-encapsulated IPv6 packet.

set ip6 conn name *name* 6rd-tunnel ipv4-tx-to-br [off | on]

off means each packet set to a destination IPv6 address within the originating 6rd domain is sent directly to the 6rd endpoint. **on** means that all packets are transmitted to the 6rd border gateway.

AICCU (SixXS tunnel broker) Connections

ip6 conn (type = aiccu, side = wan). This connection type enables an IPv6 connection to the IPv6 internet over an IPv4/NAT/UDP tunnel to a tunnel endpoint administered by tunnel broker SIXXS (www.sixxs.net).

You set up an account with SIXXS, and subsequently get assigned a tunnel and a subnet (usually a /48 subnet).

set ip6 conn name *name* aiccu username *username*

Sets the connection's SIXXS username.

set ip6 conn name *name* aiccu password *password*

Sets the connection's SIXXS password.

Delegated Prefix Connections

ip6 conn (type = dp, side = lan). A conn of type “delegated prefix” obtains its global prefix information from one or more prefix from another IPv6 conn (typically a WAN conn), if available. In order for a “dp” connection to become fully operational, its underlying link must be up AND the IPv6 connection which delegates the prefix must have created one or more prefixes from which to draw the “dp” connection's global prefix.

set ip6 conn name *name* dp link-oid *link_name*

Sets the connection to obtain its prefix from the specified link.

set ip6 conn name *name* dp conn-oid *ipv6_conn_name*

Sets the dp connection named *name* to obtain its prefix from IPv6 connection named *ipv6_conn_name*.

set ip6 conn name *name* dp subnet-length *value* [0 - 16]

The length of the subnet portion of the delegated prefix. Default is 0.

set ip6 conn name *name* dp subnet-id *value* [0 - 65535]

If a subnet length is specified, the value that would occupy the of the subnet portion of the conn's IPv6 prefix. Default is 0.

set ip6 conn name *name* dp stay-up [off | on]

If the delegated prefix parameter **stay-up** is set to **on**, the global prefix assigned from the conn delegating the prefix remains active in the event that the conn delegating the prefix goes down, and the prefix becomes invalid. This enables local LAN-side hosts to continue to use the global prefix uninterrupted. If parameter **stay-up** is set to **off**, the connection's delegated prefix becomes invalid when the connection named **ip6-conn-name** delegating the prefix goes down.

Router Advertisement and DHCPv6 Server

ip6 conn (side = lan). Router Advertisements and the DHCPv6 server are available on LAN-side conns as the means to provide clients with stateful or stateless IPv6 prefixes and addresses, as well as addition client parameters such as MTU size and IPv6-addressable DNS servers.

set ip6 conn name *name* radv enable [off | on]

on means radv is enabled for this conn.

set ip6 conn name *name* radv min-rtr-adv-interval *seconds* [3 - 1350]

The minimum time allowed between sending unsolicited multicast router advertisements from the link, in seconds.

set ip6 conn name *name* radv max-rtr-adv-interval *seconds* [4 - 1800]

The maximum time allowed between sending unsolicited multicast router advertisements from the interface, in seconds.

set ip6 conn name *name* dhcp-server enable [off | on]

on means the DHCPv6 server is enabled for this conn.

set ip6 conn name *name* dhcp-server addr-count *value* [0 - 256]

The number of IPv6 addresses available to serve to DHCPv6 stateful clients. If the **addr-count** parameter is set to zero, the DHCPv6 server operates in “stateless” mode.

set ip6 conn name *name* dhcp-server start-addr-offset *value* [0 - 65536]

If the **addr-count** parameter is greater than zero, the start address is an offset from the base address of the prefix which is assigned to the LAN conn.

set ip6 conn name *name* dhcp-server lease-time *seconds* [180 - 8553600]

DHCPv6 lease time.

set ip6 conn name *name* dhcp-server dns-server optional IPv6 address

IPv6 address of advertised DNS server (optiona).

IPv6 DHCP Server

set ip6 dhcp-server enable [on | off]

Globally enables or disables DHCPv6 servers on all IPv6 LAN conns. The default is **on**.

set ip6 dhcp-server information-only [off | on]

When set to **on** DHCPv6 servers on all IPv6 LAN conns operate in stateless “information-only” mode. The default is **off**.

set ip6 dhcp-server preference 255

Sets the preference option, as defined in RFC1315, sec. 22.8. The preference option in the server’s Advertise message may assist a DHCPv6 client in selecting from more than one server on the LAN.

set ip6 dhcp-server authoritative [on | off]

If a client requests an IP address on a given network segment that the server knows is not valid for that segment, and **authoritative** is set to **on**, the server will respond with a DHCPNAK message, causing the client to forget its IP address and try to get a new one. If **authoritative** is set to **off**, the server will ignore the client’s request. The default is **on**.

set ip6 dhcp-server rapid-commit [on | off]

Enables or disables the rapid commit option per rfc3315 sec 22.14. (<http://tools.ietf.org/html/rfc3315#section-22.14>) The default is **on**.

set ip6 dhcp-server unicast [off | on]

Enables or disables server unicast option per rfc3315 sec 22.12. (<http://tools.ietf.org/html/rfc3315#section-22.12>) The default is **off**.

set ip6 dhcp-server leasequery [off | on]

Enables or disables DHCPv6 Leasequery option per rfc5007. (<http://tools.ietf.org/rfc/rfc5007.txt>) The default is **off**.

set ip6 dhcp-server pd-enable [on | off }

Enables or disables prefix delegation globally on all DHCPv6 servers on all IPv6 LAN conns, overriding individual DHCPv6 server settings. The default is **on**.

set ip6 dhcp-server default-lease-time *seconds*

Sets the global DHCPv6 lease time setting in seconds. The default is **2592000** (30 days).

set ip6 dhcp-server preferred-lifetime *seconds*

Sets the global DHCPv6 preferred lifetime of prefixes in seconds, per RFC 3633. (<http://www.ietf.org/rfc/rfc3633.txt>) The default is **604800** (7 days).

set ip6 dhcp-server T1 *seconds*

set ip6 dhcp-server T2 *seconds*

Sets global DHCPv6 T1, T2 values, per RFC 3315 for local NA addresses:

-
- | | |
|-----------|--|
| T1 | The time at which the client contacts the server from which the addresses in the IA_NA were obtained to extend the lifetimes of the addresses assigned to the IA_NA; T1 is a time duration relative to the current time expressed in units of seconds. Defaults to 302400 (3.5 days). |
| T2 | The time at which the client contacts any available server to extend the lifetimes of the addresses assigned to the IA_NA; T2 is a time duration relative to the current time expressed in units of seconds. Defaults to 483840 (5.6 days). |

and also per global DHCPv6 T1, T2 values, per RFC 3633 for PD prefixes:

-
- | | |
|-----------|---|
| T1 | The time at which the requesting router should contact the delegating router from which the prefixes in the IA_PD were obtained to extend the lifetimes of the prefixes delegated to the IA_PD; T1 is a time duration relative to the current time expressed in units of seconds. |
| T2 | The time at which the requesting router should contact any available delegating router to extend the lifetimes of the prefixes assigned to the IA_PD; T2 is a time duration relative to the current time expressed in units of seconds. |

set ip6 dhcp-server info-refresh-time *seconds*

In seconds, per rfc 4242: The information refresh time option specifies an upper bound for how long a client should wait before refreshing information retrieved from DHCPv6 in stateless mode. (<http://tools.ietf.org/html/rfc4242>) The default is **86400** (24 hours).

Static Routes

ip6 static-route.

set ip6 static-route *name conn-oid ipv6_conn_name*

Route is directed to IPv6 connection named *ipv6_conn_name*.

set ip6 static-route *name* **nexthop** *IPv6_address*

Next-hop IPv6 address for forwarding. Can be a global or link-local address.

set ip6 static-route *name* **prefix** *IPv6_prefix*

IPv6 prefix.

set ip6 static-route *name* **prefix-length** *value* [1 - 64]

IPv6 prefix-length.

set ip6 static-route *name* **metric** *value* [0 - 255]

metric assigned to route.

IP DNS commands

set ip dns domain-name *domain_name*

Specifies the default domain name for your network. When an application needs to resolve a host name, it appends the default domain name to the host name and asks the DNS server if it has an address for the “fully qualified host name.”

set ip dns primary-address *ip_address*

Specifies the IP address of the primary DNS name server.

set ip dns secondary-address *ip_address*

Specifies the IP address of the secondary DNS name server. Enter **0.0.0.0** if your network does not have a secondary DNS name server.

set ip dns proxy-enable [on | off]

This allows you to disable the default behavior of acting as a DNS proxy. The default is **on**.

IP IGMP commands

Multicasting is a method for transmitting large amounts of information to many, but not all, computers over an internet. One common use is to distribute real time voice, video, and data services to the set of computers which have joined a distributed conference. Other uses include updating the address books of mobile computer users in the field, or sending out company newsletters to a distribution list.

Since a router should not be used as a passive forwarding device, ARRIS Gateways use a protocol for forwarding multicasting: Internet Group Management Protocol (IGMP).

ARRIS Gateways support IGMP Version 1, Version 2, or Version 3.

IGMP “Snooping” is a feature of Ethernet layer 2 switches that “listens in” on the IGMP conversation between computers and multicast routers. Through this process, it builds a database of where the multicast routers reside by noting IGMP general queries used in the querier selection process and by listening to other router protocols.

From the host point of view, the snooping function listens at a port level for an IGMP report. The switch then processes the IGMP report and starts forwarding the relevant multicast stream onto the host's port. When the switch receives an IGMP leave message, it processes the leave message, and if appropriate stops the multicast stream to that particular port. Basically, customer IGMP messages although processed by the switch are also sent to the multicast routers.

In order for IGMP snooping to function with IGMP Version 3, it must always track the full source filter state of each host on each group, as was previously done with Version 2 only when Fast Leave support was enabled.

IGMP Version 3 supports:

IGMP Source Filtering: the ability for group memberships to incorporate source address filtering. This allows "Source-Specific Multicast" (SSM). By adding source filtering, a Gateway that proxies IGMP can more selectively join the specific multicast group for which there are interested LAN multicast receivers.

These features require no user configuration on the Gateway.

You can set the following options:

- ◆ **IGMP Snooping** – enables the ARRIS Gateway to "listen in" to IGMP traffic. The Gateway discovers multicast group membership for the purpose of restricting multicast transmissions to only those ports which have requested them. This helps to reduce overall network traffic from streaming media and other bandwidth-intensive IP multicast applications.
- ◆ **Robustness** – a way of indicating how sensitive to lost packets the network is. IGMP can recover from robustness minus 1 lost IGMP packet. The default value is 2.
- ◆ **Query Interval**– the amount of time in seconds between IGMP General Query messages sent by the querier gateway. The default query interval is 125 seconds.
- ◆ **Query Response Interval** – the maximum amount of time in tenths of a second that the IGMP Gateway waits to receive a response to a General Query message. The default query response interval is 10 seconds and must be less than the query interval.
- ◆ **Unsolicited Report Interval** – the amount of time in seconds between repetitions of a particular computer's initial report of membership in a group. The default unsolicited report interval is 10 seconds.
- ◆ **Querier Version** – select a version of the IGMP Querier: version **1**, version **2**, or version **3**. If you know you will be communicating with other hosts that are limited to v1 or v2, for backward compatibility, select accordingly; otherwise, allow the default v3.



NOTE:

IGMP Querier version is relevant only if the Gateway is configured for IGMP forwarding. If any IGMP v1 routers are present on the subnet, the querier must use IGMP v1. The use of IGMP v1 must be administratively configured, since there is no reliable way of dynamically determining whether IGMP v1 routers are present on a network. IGMP forwarding is enabled per IP Profile and WAN Connection Profile.

-
- ◆ **Last Member Query Interval** – the amount of time in tenths of a second that the IGMP gateway waits to receive a response to a Group-Specific Query message. The last member query interval is also the amount of time in seconds between successive Group-Specific Query messages. The default last member query interval is 1 second (10 deci-seconds).
 - ◆ **Last Member Query Count** – the number of Group-Specific Query messages sent before the gateway assumes that there are no members of the host group being queried on this interface. The default last member query count is 2.
 - ◆ **Fast Leave** – set to **off** by default, fast leave enables a non-standard expedited leave mechanism. The querier keeps track of which client is requesting which channel by IP address. When a leave message is received, the querier can check its internal table to see if there are any more clients on this group. If there are none, it immediately sends an IGMP leave message to the upstream querier.
 - ◆ **Log Enable** – If set to on, all IGMP messages on both the LAN and the WAN will be logged.
 - ◆ **Wi-Fi Multicast to Unicast conversion** – Only available if **IGMP Snooping** is enabled. If set to **on**, the Gateway replaces the multicast MAC-address with the physical MAC-address of the Wi-Fi client. If there is more than one Wi-Fi client interested in the same multicast group, the Gateway will revert to multicasting the

stream immediately. When one or more Wi-Fi clients leave a group, and the Gateway determines that only a single Wi-Fi client is interested in the stream, it will once again unicast the stream.

set ip igmp querier-version [1 | 2 | 3]

Sets the IGMP querier version: version **1**, version **2**, or version **3**. If you know you will be communicating with other hosts that are limited to v1, for backward compatibility, select **1**; otherwise, allow the default **3**.

set ip igmp robustness *value*

Sets IGMP robustness range: from 2 – 255. The default is 2.

set ip igmp query-interval *value*

Sets the query-interval range: from 10 seconds – 600 seconds, The default is 125 seconds.

set ip igmp query-response-interval *value*

Sets the query-response interval range: from 5 deci-seconds (tenths of a second) – 255 deci-seconds. The default is 100 deci-seconds.

set ip igmp unsolicited-report-interval *value*

Sets the unsolicited report interval: the amount of time in seconds between repetitions of a particular computer's initial report of membership in a group. The default is 10 seconds.

set ip igmp fast-leave [off | on]

Sets fast leave **on** or **off**. Set to **on** by default, fast leave enables a non-standard expedited leave mechanism. The querier keeps track of which client is requesting which channel by IP address. When a leave message is received, the querier can check its internal table to see if there are any more clients on this group. If there are none, it immediately sends an IGMP leave message to the upstream querier.

set ip igmp max-group-memberships *value*

Sets the maximum number of IGMP group memberships. Default is **20**.

set ip igmp fwd-admin-groups [off | on]

Turns Admin group forwarding off or on. Default is **off**.

set ip igmp last-member-interval *value*

Sets the last member query interval: the amount of time in tenths of a second that the IGMP gateway waits to receive a response to a Group-Specific Query message. The last member query interval is also the amount of time in seconds between successive Group-Specific Query messages. The default is 1 second (10 deci-seconds).

set ip igmp last-member-count *value*

Sets the last member query count: the number of Group-Specific Query messages sent before the gateway assumes that there are no members of the host group being queried on this interface. The default is 2.

set ip igmp default-fwd-allow [on | off]

Turns default forwarding on or off. The default is **on**.

set ip igmp snoop-entry-time *seconds*

The **snoop-entry-time** is the amount of time an entry will remain in the snooping table (in seconds) after being added. An entry is added when a “JOIN” is seen from a multicast client. Any new joins (triggered by upstream queries) will reset the timeout back to *seconds*. If no additional joins are seen, the entry will expire after *seconds*. Default is **130**.

set ip igmp snooping-unreg-mode [**block** | **flood**]

The **snooping-unreg-mode** can be set to **block** or **flood**. This indicates what should happen to unregistered multicast traffic – traffic that hasn't been subscribed to by any clients. If set to **flood**, the traffic will be sent to all LAN ports. If set to **block**, the traffic will not be sent to any LAN ports; it will be dropped. Default is **block**.

NTP commands

set ip ntp enable [**on** | **off**]

Enables or disables acquiring the time of day from an NTP (Network Time Protocol) server.

set ip ntp server-address *server_address*
set ip ntp alt-server-address *alt_server_address*

Specify the NTP server(s) to use for time updates. The NTP **server-address** and **alt-server-address** can be entered as DNS names as well as IP addresses.

set ip ntp update-period *minutes*

update-period specifies how often, in minutes, the Gateway should update the clock. Default is **1440**.

Application Layer Gateway (ALG) commands

These commands allow you to enable or disable the router's support for a variety of Application Layer Gateways (ALGs). An application layer gateway (ALG) is a NAT component that helps certain application sessions to pass cleanly through NAT. Each ALG has a slightly different function based on the particular application's protocol-specific requirements.

An internal client first establishes a connection with the ALG. The ALG determines if the connection should be allowed or not and then establishes a connection with the destination computer. All communications go through two connections – client to ALG and ALG to destination. The ALG monitors all traffic against its rules before deciding whether or not to forward it. The ALG is the only address seen by the public Internet so the internal network is concealed. In some situations, it may be desirable to disable some of the ALGs.

set ip alg esp-enable [**on** | **off**]

Turns the ESP (Encapsulated Security Payload) ALG for file transfers **on** or **off**. Default is **on**.

set ip alg esp-setup-timeout *value*

Specifies the timeout value for the ESP ALG setup. Default is **180**.

set ip alg esp-stream-timeout *value*

Specifies the timeout value for the ESP ALG streaming. Default is **300**.

set ip alg ftp-enable [on | off]

Turns the FTP (File Transfer Protocol) ALG for file transfers **on** or **off**. Default is **on**.

set ip alg h323-enable [on | off]

Turns the H323 ALG for audio, video, and data communications across IP-based networks **on** or **off**. Default is **on**.

set ip alg pptp-enable [on | off]

Turns the PPTP (Point-to-Point Transfer Protocol) ALG for authentication **on** or **off**. Default is **on**.

set ip alg sip-enable [on | off]

Turns the SIP (Session Initiation Protocol) ALG for voice communication initiation **on** or **off**. Default is **on**.

set ip alg tftp-enable [on | off]

Turns the TFTP (Trivial File Transfer Protocol) ALG for simple file transfers and firmware updates **on** or **off**. Default is **on**.

Dynamic DNS Commands

set ip dynamic-dns enable [off | on]

Enables or disables Dynamic DNS. Dynamic DNS support allows you to use the free services of www.dyndns.org. Dynamic DNS automatically directs any public Internet request for your computer's name to your current dynamically-assigned IP address. This allows you to get to the IP address assigned to your Gateway, even though your actual IP address may change as a result of a PPPoE connection to the Internet.

set ip dynamic-dns service-type [dyndns]
set ip dynamic-dns username *myusername*
set ip dynamic-dns password *mypassword*
set ip dynamic-dns hostname *myhostname*
set ip dynamic-dns retries [1 - 64]

Enables or disables dynamic DNS services. The default is **off**. If you specify **dyndns.org**, you must supply your hostname, username for the service, and password. Number of retries defaults to **5**.

Default server settings

Set ip wan-allocation mode [normal | defaultserver]

Sets the WAN mode to direct your Gateway to forward all externally initiated IP traffic (TCP and UDP protocols only) to a default host on the LAN, otherwise this feature is disabled. Default is **normal**.

Link commands

links represent physical connections. Currently, port-based VLAN support is provided at this level. Your Gateway is capable of adding and stripping 802.1Q tags to and from frames before transmission on its LAN interfaces. See also [“Filterset commands” on page 126](#) and [“Queue commands” on page 130](#) for more information.

set link name *name* type [ethernet | ppp]

Specifies whether the **type** of the link named *name* is **ethernet** or **ppp**.

set link name *name* mtu-override [0 - 1500]

Specifies whether the **Maximum Transmission Unit** value should be set to other than the standard 1500. A setting of 0 (zero) turns off override.

set link name *name* igmp-snooping [off | on]

Turns **igmp-snooping** **off** or **on** on the link named *name*.

set link name *name* port-vlan ports [lan-1... 4 | hpna | ssid-1...4 | ptm | vc-1 | vc-2]

Specifies a port-based VLAN on the selected ports on the link named *name*.

set link name *name* port-vlan priority [0 - 7]

Specifies the 802.1p priority bit. If you set this to a value greater than 0, all packets of this VLAN with unmarked priority bits (pbits) will be re-marked to this priority.

set link name *name* tagged-vlan name *integer* ports [lan-1... 4 | hpna | ssid-1...4 | ptm | vc-1 | vc-2]

Specifies a tagged VLAN on the selected port on the link named *name*. Default is **ptm**.

set link name *name* tagged-vlan name *integer* vid *vlan_id*

Specifies a VLAN ID (*vid*) on the selected link named **name**. Default is **0**.

set link name *name* tagged-vlan name *integer* priority [0 - 7]

Specifies the 802.1p priority bit. If you set this to a value greater than 0, all packets of this VLAN with unmarked priority bits (pbits) will be re-marked to this priority.

set link name *name* supplicant type [none | eap-tls]

Specifies whether the EAP TLS supplicant is enabled on the link named **name**. Default is **eap-tls**.

set link name *name* supplicant priority [0 - 7]

Sets the supplicant priority on the link named **name** when **supplicant type** is **eap-tls**. Default is **0**.

set link name *name* ppp sub-link *link_name*

Specifies a name **link_name** for this secondary link when one is required.

set link name *name* ppp auth-type [on | off]

Enables or disables PPP login authorization.

set link name *name* ppp username *uname*

Specifies a username **uname** for authentication on the specified link when **ppp auth-type** is set to **on**.

set link name *name* **ppp password** *pwd*

Specifies a password *pwd* for authentication on the specified link when **ppp auth-type** is set to **on**.

set link name *name* **ppp magic-number** [**on** | **off**]

Enables or disables LCP magic number negotiation.

set link name *name* **ppp protocol-compression** [**off** | **on**]

Specifies whether you want the Gateway to compress the PPP Protocol field when it transmits datagrams over the PPP link.

set link name *name* **ppp max-failures** *integer*

Specifies the maximum number of Configure-NAK messages the PPP module can send without having sent a Configure-ACK message. The *integer* argument can be any number between 1 and 20.

set link name *name* **ppp max-configures** *integer*

Specifies the maximum number of unacknowledged configuration requests that your Gateway will send. The *integer* argument can be any number between 1 and 20.

set link name *name* **ppp max-terminates** *integer*

Specifies the maximum number of unacknowledged termination requests that your Gateway will send before terminating the PPP link. The *integer* argument can be any number between 1 and 10.

set link name *name* **ppp restart-timer** *integer*

Specifies the number of seconds the Gateway should wait before retransmitting a configuration or termination request. The *integer* argument can be any number between 1 and 30.

set link name *name* **ppp connection-type** [**instant-on** | **always-on**]

Specifies whether a PPP connection is maintained by the ARRIS[®] Gateway when it is unused for extended periods. If you specify **always-on**, the Gateway never shuts down the PPP link. If you specify **instant-on**, the Gateway shuts down the PPP link after the number of seconds specified in the time-out setting (below) if no traffic is moving over the circuit.

set link name *name* **ppp echo-request** [**on** | **off**]

Specifies whether you want your Gateway to send LCP echo requests. You should turn off LCP echoing if you do not want the Gateway to drop a PPP link to a nonresponsive peer.

set link name *name* **ppp echo-failures** *integer*

Specifies the maximum number of lost echoes the Gateway should tolerate before bringing down the PPP connection. The *integer* argument can be any number from between 1 and 20.

set link name *name* **ppp echo-interval** *integer*

Specifies the number of seconds the Gateway should wait before sending another echo from an LCP echo request. The *integer* argument can be any number from between 5 and 300 (seconds).

set link name *name* ppp mru *integer*

Specifies the Maximum Receive Unit (MRU) for the PPP interface. The *integer* argument can be any number between 128 and 1492 for PPPoE; 1500 otherwise.

set link name *name* ppp peer-dns [on | off]

Controls whether the Gateway accepts nameserver addresses from the peer.

- ◆ The default is **on**, which means the Gateway expects to get nameserver addresses when the PPP link comes up. This especially applies when the primary WAN connection is PPP.
- ◆ However, there are some unusual situations where the PPP connection is **not** the primary WAN, for example when the connection is used only for management. In that situation it may be desirable to **not** pick up more nameserver addresses. You can do that by setting the parameter to **off**.

**NOTE:**

This is an expert-mode setting that will rarely be used. The setting should be left on, unless you are an expert user who knows you do not want the Gateway to acquire any nameserver addresses from this PPP connection.

Specifies an ISP name or a class or quality of service. The Service Name tells the access concentrator which network service the ARRIS® Gateway is trying to reach.

set link name *name* pppoe ac-name *name*

Specifies this particular Access Concentrator unit from all others.. Some access provider networks may have multiple PPPoE servers, and having the ARRIS® Gateway indicate an AC Name specifies to which one the ARRIS® Gateway is trying to connect.

Management commands

All management related items are grouped in this section.

set management account administrator username *username*

Specifies the **username** for the administrative user – the default is **admin**.

set management account user username *username*

Specifies the **username** for the non-administrative user – the default is **user**.

set management cwmp enable [off | on]

Turns **cwmp** (TR-069 CPE WAN Management Protocol) **on** or **off**. TR-069 allows a remote Auto-Config Server (ACS) to provision and manage the ARRIS Gateway. TR-069 protects sensitive data on the Gateway by not advertising its presence, and by password protection.

set management cwmp acs-url *acs_url:port_number***set management cwmp acs-username *acs_username*****set management cwmp acs-password *acs_password***

If TR-069 WAN side management services are enabled, specifies the auto-config server URL and port number. A username and password must also be supplied, if TR-069 is enabled.

The auto-config server is specified by URL and port number. The format for the ACS URL is as follows:

```
http://some_url.com:port_number
```

or

```
http://123.45.678.910:port_number
```

On units that support SSL, the format for the ACS URL can also be:

```
https://some_url.com:port_number
```

or

```
https://123.45.678.910:port_number
```

TR-064

Forum LAN Side CPE Configuration (TR-064) is an extension of UPnP. It defines more services to locally manage the ARRIS® Device. While UPnP allows open access to configure the Device's features, TR-064 requires a password to execute any command that changes the Device's configuration.

set management lanmgmt enable [off | on]

Turns TR-064 LAN side management services on or off. The default is **off**.

set management shell idle-timeout [1...120]

Specifies a timeout period of inactivity for telnet access to the Gateway, after which a user must re-login to the Gateway. Default is **15** minutes for telnet.

set management shell ssh-port [1 - 65534]

Specifies the port number for secure shell (SSH) communication with the ARRIS® Gateway. Defaults to port **0** (off).

set management shell telnet-port [1 - 65534]

Specifies the port number for telnet (CLI) communication with the ARRIS® Gateway. Because port numbers in the range 0-1024 are used by other protocols, you should use numbers in the range 1025-65534 when assigning new port numbers to the ARRIS® Gateway telnet configuration interface. A setting of **0** (zero) will turn the server off.

set management upnp enable [off | on]

Turns Universal Plug-and-Play (UPnP) on or off.

set management web http-port [1 - 65534]

Specifies the port number for HTTP (web) communication with the ARRIS® Gateway. Because port numbers in the range 0-1024 are used by other protocols, you should use numbers in the range 1025-65534 when assigning new port numbers to the ARRIS® Gateway web configuration interface. A setting of **0** (zero) will turn the server off.

set management web https-port [1 - 65534]

Sets the secure web access port for secure management of the ARRIS® Gateway. Default is port **443**.

set management web https-cert-cn *string*

Specifies a certificate from a trusted certificate authority to identify the secure web access.

set management web idle-timeout [1...120]

Specifies a timeout period of inactivity for HTTP access to the Gateway, after which a user must re-login to the Gateway. Default is **5** minutes for HTTP.

**NOTE:**

You cannot specify a port setting of 0 (zero) for both the web and telnet ports at the same time. This would prevent you from accessing the Gateway.

set management web isp-help-desk *phone_number_string*

Specifies the ISP Help Desk phone number as it appears in the web UI. For AT&T, the default is: 1-800-288-2020.

Remote access commands

set management remote-access http-port [1 - 65534]

Sets the web access port for remote access management of the Gateway. Default is port **51003**.

set management remote-access http-idle-timeout [1...120]

Specifies a timeout period of inactivity for remote HTTP access to the Gateway, after which a user must re-login to the Gateway. Default is **20** minutes for HTTP.

set management remote-access http-total-timeout [1...120]

Specifies a total timeout period of inactivity for remote HTTP access to the Gateway, after which a user must re-login to the Gateway. Default is **20** minutes for HTTP.

set management remote-access http-max-clients *number*

Specifies the maximum number of client sessions for remote web access management. Defaults to 1 (one).

set management remote-access https-port [1 - 65534]

Sets the secure web access port for remote access management of the Gateway. Default is port **51443**.

set management remote-access https-idle-timeout [1...120]

Specifies a timeout period of inactivity for secure remote HTTPS access to the Gateway, after which a user must re-login to the Gateway. Default is **20** minutes for HTTPS.

set management remote-access https-total-timeout [1...120]

Specifies a total timeout period of inactivity for secure remote HTTPS access to the Gateway, after which a user must re-login to the Gateway. Default is **20** minutes for HTTPS.

set management remote-access https-max-clients *number*

Specifies the maximum number of client sessions for secure remote web access management. Defaults to 1 (one).

set management remote-access telnet-port [1 - 65534]

Specifies the port number for remote access telnet (CLI) communication with the ARRIS® Gateway. Because port numbers in the range 0-1024 are used by other protocols, you should use numbers in the range 1025-65534 when assigning new port numbers to the ARRIS® Gateway telnet configuration interface. A setting of 0 (zero) will turn the server off. Defaults to port 0.

set management remote-access telnet-idle-timeout [1...120]

Specifies a timeout period of inactivity for remote telnet access to the Gateway, after which a user must re-login to the Gateway. Default is 5 minutes for telnet.

set management remote-access telnet-total-timeout [1...120]

Specifies a total timeout period of inactivity for remote telnet access to the Gateway, after which a user must re-login to the Gateway. Default is 20 minutes for telnet.

set management remote-access telnet-max-clients *number*

Specifies the maximum number of client sessions for remote telnet access management. Defaults to 4.

set management remote-access ssh-port [1 - 65534]

Specifies the port number for secure shell (SSH) communication with the ARRIS® Gateway. Defaults to port 22.

set management remote-access ssh-idle-timeout [1...120]

Specifies a timeout period of inactivity for remote secure shell (SSH) access to the Gateway, after which a user must re-login to the Gateway. Default is 5 minutes for SSH.

set management remote-access ssh-total-timeout [1...120]

Specifies a total timeout period of inactivity for remote secure shell (SSH) access to the Gateway, after which a user must re-login to the Gateway. Default is 20 minutes for SSH.

set management remote-access ssh-max-clients *number*

Specifies the maximum number of client sessions for remote secure shell (SSH) access management. Defaults to 4.

set management lan-redirect enable [off | on]

If set to **on**, if a WAN failure condition is detected, the LAN client's browser is redirected to a web page of failure and help text information. The redirect will only occur once, as the web UI maintains a state variable to determine whether the redirect has occurred; to continually redirect would block the user from reconfiguring the router.

set management lan-redirect missing-filter-notify [on | off]

If set to **on**, if a missing filter on the line is detected, the LAN client's browser is redirected to a web page of failure and help text information. The redirect will only occur once, as the web UI maintains a state variable to determine whether the redirect has occurred; to continually redirect would block the user from reconfiguring the router.

set management lan-access wan-cpe-mgmt-block [off | web | all]

Blocks management of the device from the LAN via the web or all interface(s).

TR-064

DSL Forum LAN Side CPE Configuration (TR-064) is an extension of UPnP. It defines more services to locally manage the ARRIS® Gateway. While UPnP allows open access to configure the Gateway's features, TR-064 requires a password to execute any command that changes the Gateway's configuration.

set management lanmgmt enable [off | on]

Turns TR-064 LAN side management services on or off. The default is **off**.

Physical interfaces commands

Ethernet interfaces

set physical enet [1 - 4] mac-addr-override *mac_addr*

You can override your Gateway's Ethernet MAC address with any necessary setting. Some ISPs require your account to be identified by the MAC address, among other things. Enter your 12-character Ethernet MAC override address as instructed by your service provider, for example: 12 34 AB CD 19 64

set physical enet [1 - 4] port media [auto | 100-fd | 100-hd | 10-fd | 10-hd]

Sets the Ethernet port's media flow control: Automatic, 100 Mbps Full-Duplex, 100 Mbps Half-Duplex, 10 Mbps Full-Duplex, or 10 Mbps Half-Duplex. Default is **auto**.

set physical enet [1 - 4] port mdix [auto | on | off]

Sets the Ethernet port's crossover detection. Default is **off**.

set physical enet [1 - 4] tx-queue *queue_name*

Attaches the egress queue template to the ethernet interface when the queue type is egress.

set physical enet [1 - 4] rx-queue *queue_name*

Attaches the ingress queue to the ethernet interface when the queue type is ingress.

set physical enet [1 - 4] port power-save enable ""

Turns power saving mode off or on.

set physical ensw max-age *seconds*

Sets the maximum delay on the Ethernet switch in seconds. Default is 300 (5 minutes).

set physical ensw qos-mode [off | p-bit]

Sets QoS up on Ethernet switch, classified by priority-bit mapping. Default is **off**. When **p-bit** is selected, packets will be mapped from their priority (even if untagged) to one of four queues per-port in the Ethernet switch.

See [“Quality of Service \(QoS\) Examples” on page 213](#) for more information.



NOTE:

This only applies to packets sent from the host CPU to a switch port; it does not apply to port-to-port traffic.

set physical ensw p-bit-map *pbit-to-4queue-map*

Sets the mapping from the 8 priority-bits to the four queues in the Ethernet switch. The lowest priority queue is “1”, and the highest priority queue is “4”.

Example: Mapping is “1 1 2 2 3 3 4 4”, where priority bit values 0 and 1 would map to queue 1, and values 2 and 3 would map to queue 2, etc.

Wi-Fi interfaces

set physical Wi-Fi enable [on | off]

Enables or disables the Wi-Fi capability for supported Wi-Fi Gateways. Default is **on**.

set physical Wi-Fi standard [bg | b-only | g-only | bgn | n-only | an | a-only]

Sets and locks the Gateway into the Wi-Fi transmission mode you want: **bg**, **b-only**, **g-only**, **bgn**, **n-only**, **an**, or **a-only**. For compatibility with clients using 802.11b (up to 11 Mbps transmission), 802.11g (up to 20+ Mbps), 802.11a (up to 54 Mbit/s using the 5 GHz band), or 802.11n (from 54 Mbit/s to 600 Mbit/s with the use of four spatial streams at a channel width of 40 MHz), select **B/G/N**. To limit your Wi-Fi LAN to one mode or the other, select **G-only**, **N-only**, **A-only**, or **B-only**, or some combination that applies to your setup. Default is **bgn**.

set physical Wi-Fi auto-channel [off | on]

Turns auto-channel selection **on** or **off**.

set physical Wi-Fi bandwidth [narrow | wide]

Specifies whether the Wi-Fi channel is **narrow** or **wide** band. Default is **narrow** in compliance with FCC requirements.

set physical Wi-Fi default-channel [1... 11]

(1 through 11, for North America) on which the network will broadcast. This is a frequency range within the 2.4GHz band. Channel selection can have a significant impact on performance, depending on other Wi-Fi activity close to this Router. Channel selection is not necessary at the client computers; the clients will scan the available channels seeking access points using the same SSID as the client. Defaults to **6**.

set physical Wi-Fi power [1 - 100]

Sets some value lower than 100 percent transmit power if your Gateway is located close to other Wi-Fi Gateways and causes interference. Defaults to **100** (percent).

set physical Wi-Fi mul2uni [off | on]

Turns Wi-Fi “many-to-one” packet scheduling **off** or **on**. Default is **off**.

set physical Wi-Fi ssid 1 enable [on | off]

Enables or disables the first (default) Wi-Fi SSID.

set physical Wi-Fi ssid 1 name *name*

Specifies a name for the first Wi-Fi SSID. Defaults to a unique value per router of the form “ATTxxx”.

set physical Wi-Fi ssid 1 access-type [none | allow | deny]

Specifies the type of address list for defining MAC address filtering. If set to **allow**, only hosts with the specified addresses will be permitted to join the WLAN of the specified SSID. If set to **deny**, any hosts except those with the specified addresses will be permitted to join the specified SSID. Default is **none**.

set physical Wi-Fi ssid 1 access-list *mac_address*

Specifies the MAC address of devices controlled by MAC address filtering.

set physical Wi-Fi ssid 1 hidden [off | on]

Enables or disables SSID hiding for the specified SSID. If set to **on**, the specified SSID will not appear on client scans. Clients must log into the SSID with the exact SSID name and credentials specified for that SSID.

set physical Wi-Fi ssid 1 isolate [off | on]

If set to **on**, blocks Wi-Fi clients from communicating with other Wi-Fi clients on the WLAN side of the Gateway. Defaults to **off**.

set physical Wi-Fi ssid 1 security [none | wep | wpa]

Sets the Wi-Fi privacy type: **none**, **wep**, or **wpa-psk**. Default is **none**.

set physical Wi-Fi ssid 2 enable [off | on]

Enables or disables the second available SSID.

set physical Wi-Fi ssid 3 enable [off | on]

Enables or disables the third available SSID.

set physical Wi-Fi ssid 4 enable [off | on]

Enables or disables the fourth available SSID.

set physical Wi-Fi wps [on | off]

Enables or disables Wi-Fi Protected Setup (WPS) for simplified security configuration with Wi-Fi clients that support it.

set physical Wi-Fi wmm enable [off | on]

Enables or disables Wi-Fi Multimedia settings for multimedia queueing characteristics.

set physical Wi-Fi wmm power-save [off | on]

Turns power saving mode **off** or **on** for Wi-Fi multimedia when **wmm enable** is **on**. Default is **on**.

PPPoE relay commands



NOTE:

When configuring a PPPoE connection, you must also configure the required PPPoE authentication details (such as user name and password combinations) on the client computer.

set pppoe-relay enable [on | off]

Allows the Gateway to forward PPPoE packets. Default is **on**.

set pppoe-relay max-sessions [0... 4]

Specifies the maximum number of PPPoE relay sessions. Default is **4**.

NAT Pinhole commands

NAT pinholes let you pass specific types of network traffic through the NAT interfaces on the ARRIS® Gateway. NAT pinholes allow you to route selected types of network traffic, such as FTP requests or HTTP (Web) connections, to a specific host behind the ARRIS® Gateway transparently.

To set up NAT pinholes, you identify the type(s) of traffic you want to redirect by port number, and you specify the internal host to which each specified type of traffic should be directed.

The following list identifies protocol type and port number for common TCP/IP protocols:

- ◆ FTP (TCP 21)
- ◆ telnet (TCP 23)
- ◆ SMTP (TCP 25),
- ◆ TFTP (UDP 69)

set pinhole name *name* protocol [tcp | udp]

Specifies the identifier for the entry in the Gateway's pinhole table. You can name pinhole table entries sequentially (1, 2, 3), by port number (21, 80, 23), by protocol, or by some other naming scheme. Specifies the type of protocol being redirected.

set pinhole name *name* ext-port-range [0 - 49151]

Specifies the first and last port number in the range being translated.

set pinhole name *name* int-addr *ipaddr*

Specifies the IP address of the internal host to which traffic of the specified type should be transferred.

set pinhole name *name* int-start-port [0 - 65535]

Specifies the port number your ARRIS® Gateway should use when forwarding traffic of the specified type. Under most circumstances, you would use the same number for the external and internal port.

Security Stateful Packet Inspection (SPI) commands

set security firewall-level [low | high | off]

All computer operating systems are vulnerable to attack from outside sources, typically at the operating system or Internet Protocol (IP) layers. Stateful Inspection firewalls intercept and analyze incoming data packets to determine whether they should be admitted to your private LAN, based on multiple criteria, or blocked. Stateful inspection improves security by tracking data packets over a period of time, examining incoming and outgoing packets. Outgoing packets that request specific types of incoming packets are tracked; only those incoming packets constituting a proper response are allowed through the firewall.

The **high** setting is recommended, but for special circumstances, a **low** level of firewall protection is available. You can also turn all firewall protection **off**. Defaults to **low**.

set security spi ip4 invalid-addr-drop [on | off]

Enables or disables whether Broadband packets with invalid source or destination addresses should be dropped. Default is **on**.

set security spi ip4 private-addr-drop [on | off]

Enables or disables whether Broadband packets with private source or destination addresses should be dropped. Default is **off**.

set security spi unknown-ethertypes-drop [on | off]

Enables or disables whether packets with unknown ether types are to be dropped. Default is **on**.

set security spi portscan-protect [on | off]

Enables or disables whether to detect and drop port scans. Default is **on**.

set security spi invalid-tcp-flags-drop [on | off]

Enables or disables whether packets with invalid TCP flag settings (NULL, FIN, Xmas, etc.) are to be dropped. Default is **on**.

set security spi ip4 invalid-addr-drop [on | off]

Broad sets of addresses exist that should not be used as one or both of source or destination addresses. These include the following:

IP address/mask	Source or destination
10.0.0.0/8	source
192.168.0.0/16	source
169.254.0.0/16	source
172.16.0.0/12	source

IP address/mask	Source or destination
224.0.0.0/4	Source / destination
224.0.0.0/5	Source / destination
0.0.0.0/8	Source / destination
255.255.255.255	destination

The default is **on**.

set security spi ip4 private-addr-drop [off | on]

Drops packets sourced or destined for private IPv4 addresses. The default is **off**.

set security spi flood-limit enable [on | off]

Enables or disables whether packet flooding should be detected and offending packets be dropped. Default is **on**.

set security spi flood-limit limit *pps_value*

Sets a maximum Packets Per Second (PPS) value for packet flood criterion. Defaults to **4**.

set security spi flood-limit burst-limit *max_value*

Sets a maximum value in a packet-burst for packet flood criterion. Defaults to **8**.

set security spi flood-limit icmp enable [on | off]

Enables or disables whether ICMP packet flooding should be detected and offending packets be dropped. Defaults to **on**.

set security spi flood-limit udp enable [off | on]

Enables or disables whether UDP packet flooding should be detected and offending packets be dropped. Defaults to **off**.

set security spi flood-limit tcp enable [off | on]

Enables or disables whether TCP packet flooding should be detected and offending packets be dropped. Defaults to **off**.

set security spi flood-limit tcp syn-cookie [on | off]

Allows TCP SYN cookies flooding to be excluded. Defaults to **on**.

Reflexive ACL

set security spi ip6 allow-inbound [on | off]

Turns reflexive ACL on or off for IPv6.

Reflexive Access Control Lists (ACL) provide that layer 4 Session information is used to make decisions about what packets to route. Reflexive ACL reduces exposure to spoofing and denial-of-service attacks, because desired inbound packet flows are usually in response to outbound traffic.

ARRIS 9.x Gateways use the relevant session information about whether the packet flow was initiated from the LAN side (upstream) or WAN side (downstream). If the parameter `security.spi.ip6.allow-inbound` is set to **off**, then sessions which are initiated from the WAN side are disallowed. Upstream sessions are never precluded because of reflexive ACL. (Of course there may be other reasons that particular packets are dropped.)

For IPv4, NAT is generally enabled, so reflexive ACL is usually not an issue.

VoIP commands

(supported models only)

Voice-over-IP (VoIP) refers to the ability to make voice telephone calls over the Internet. This differs from traditional phone calls that use the Public Switched Telephone Network (PSTN). VoIP calls use an Internet protocol, Session Initiation Protocol (SIP), to transmit sound over a network or the Internet in the form of data packets. Certain ARRIS Gateway models have one or more voice ports for connecting telephone handsets. These models support VoIP. If your Gateway is a VoIP model, you can configure the VoIP features.

VoIP Profile Settings

set voip profile [1 - 4] prof-enable [on | off]

Enables or disables the use and configuration of the specified VoIP profile on the ARRIS® Gateway.

set voip profile [1 - 4] proxy-server *address*

Specifies the IP address or fully-qualified domain name of the SIP proxy server that stations using the profile will connect to.

set voip profile [1 - 4] proxy-port *port*

Sets the well-known port number the station using the profile will use to connect to the SIP proxy. Default is **5060**.

set voip profile [1 - 4] proxy-transport **udp**

Assigns a proxy transport protocol to the VoIP profile. Default is **udp**.

set voip profile [1 - 4] registrar-server *address*

Specifies the IP address or fully-qualified domain name of the SIP registrar (server) that stations using the profile will connect to.

set voip profile [1 - 4] registrar-port *portnumber*

Sets the well-known port number the user agent using the profile will use to connect to the SIP registrar. Default is **5060**.

set voip profile [1 - 4] registrar-transport [tcp | udp | tls]

Assigns a registrar transport protocol to the VoIP profile. Default is **udp**.

set voip profile [1 - 4] sip-expires [0 – 65535]

Specifies the SIP registration server time-out duration from 0 – 65535 seconds for the specified profile. Default is **3600** (1 hour).

set voip profile [1 - 4] outbound-proxy-server *address*

Specifies the SIP outbound proxy server for the specified profile by fully qualified server name or IP address.

set voip profile [1 - 4] outbound-proxy-port *portnumber*

Specifies the SIP outbound proxy server port for the specified profile. Default is 5060.

set voip profile [1 - 4] sip-user-domain *name*

Sets the SIP user domain value to be used by the VoIP profile.

set voip profile [1 - 4] sip-user-port [1 - 65535]

Specifies the SIP user port for the specified phone, Default is **5060**.

set voip profile [1 - 4] sip-user-transport [tcp | udp]

Assigns a transport protocol to the identified VoIP SIP profile. Default is **udp**.

set voip profile [1 - 4] invite-expires *seconds*

Assigns the "lifespan" of a SIP "INVITE" message for the identified profile.

set voip profile [1 - 4] reinvite-expires *seconds*

Sets the amount of time a SIP user agent with the named profile will consider a "re-INVITE" message valid.

set voip profile [1 - 4] reg-retry-interval *seconds*

Specifies the number of seconds that must elapse before a SIP user agent using the named profile may attempt to retry registration.

set voip profile [1 - 4] reg-min-expires *seconds*

Assign the profile a minimum length of time until a registration expires and must be renewed.

set voip profile [1 - 4] registration-period *seconds*

Sets the amount of time that a registration remains valid.

set voip profile [1 - 4] max-retrans-invite *times*

Assign the profile a maximum number of INVITE message retries. Default: 3.

set voip profile [1 - 4] max-retrans-non-invite *times*

Assign the profile a maximum number of non-INVITE message retransmissions. Default: 4.

set voip profile [1 - 4] sip-publish-method **PUBLISH**

Set the specified profile's SIP event state publication method to PUBLISH.

set voip profile [1 - 4] sip-publish-destination "DEFAULT"

Set the specified profile's SIP event state published destination to DEFAULT.

set voip profile [1 - 4] sip-publish-destination2 "NULL"

Clear (assign to NULL) the specified SIP profile's second published destination.

set voip profile [1 - 4] sip-publish-invocation never

Set the specified profile to never invoke PUBLISH.

set voip profile [1 - 4] sip-publish-interval *seconds*

Assign the publication interval to the specified profile.

set voip profile [1 - 4] sip-publish-count -1

Set the number of SIP publication events for the profile.

set voip profile [1 - 4] sip-advanced-setting sip-hk-flash-mode info

Assign a SIP HK Flash mode to the profile.

set voip profile [1 - 4] sip-advanced-setting sip-session-refresher auto

Assign a SIP session refresh method to the identified profile.

set voip profile [1 - 4] sip-advanced-setting sip-session-timer-value [*value*]

Configure the SIP session timer value for the profile. Default: 2280.

set voip profile [1 - 4] sip-advanced-setting sip-dynamic-payload [*value*]

Set the dynamic payload value for the identified profile. Default: 101

set voip profile [1 - 4] sip-advanced-setting sip-dtmf-mode [*inband* | *rfc2833* | *info*]

Assign a DTMF signaling mode for the SIP profile.

- ◆ **inband**: sends the DTMF digits as a normal inband tone.
- ◆ **rfc2833**: (default) sends the DTMF digits as an event as part of the RTP packet header information.
- ◆ **info**: sends the DTMF digits in the SIP INFO message.

Default: rfc2833

set voip profile [1 - 4] sip-advanced-setting sip-digit-map

"O=15,I=6,S=3(*#101<:@C03>|*#103<:@C06>|T0|T*xx|T*xxx|E[2-9]11|E[01]911|1[2-9]xxxxxxxx|T[2-9]xxxxxx|[2-9]xxxxxxxx|n.)"

Assign the specified digit map to the SIP profile.

set voip profile [1 - 4] sip-advanced-setting sip-compact-header [on | off]

Sets the profile to use compact format when set to **on**. Sends the SIP messages with Compact Headers, reducing the size of the SIP messages.

set voip profile [1 - 4] sip-advanced-setting sip-q-value [0 - 10]

Assigns a prioritizing SIP q-value to the profile. Default: 10

set voip profile [1 - 4] sip-advanced-setting sip-qos-tos [0 - 255]

Specifies the SIP Diff-Serv Type of Service (ToS) values for Quality of Service (QoS) assignment. Default: 160

set voip profile [1 - 4] sip-advanced-setting sip-qos-p-bit [0 - 7]

Assigns a Quality of Service Priority bit (P-Bit) value to the SIP profile. Default: 6

set voip profile [1 - 4] sip-advanced-setting sip-qos-marker [value]

Assigns a QoS packet marker to the SIP profile. Default "VO".

set voip profile [1 - 4] sip-advanced-setting fax-redundancy-level [0 - 1]

Specifies the level of fax redundancy for t38 fax data rate management. Default: 1.

set voip profile [1 - 4] sip-advanced-setting sip-init-de-register [on | off]

Turns SIP de-registration on or off for the profile. Default: off.

set voip profile [1 - 4] sip-advanced-setting sip-known-ip-list "[string]"

Specifies a known IP address list of SIP servers for the SIP profile.

set voip profile [1 - 4] sip-advanced-setting sip-allow-ip-list "[string]"

Defines a string of named SIP servers that the profile may use.

set voip profile [1 - 4] sip-advanced-setting sip-t1-timer-value 500

Assigns a SIP t1 (estimated round trip time) value to the profile.

set voip profile [1 - 4] sip-advanced-setting sip-t2-timer-value 4000

Assigns a SIP t2 (maximum non-INVITE retransmit time) value to the profile.

set voip profile [1 - 4] sip-advanced-setting sip-t4-timer-value 5000

Assigns a SIP t4 (message clear time) value to the profile.

set voip profile [1 - 4] sip-advanced-setting sip-timer-a-value 500

Assigns a SIP A timer (UDP INVITE retransmit interval) value to the profile.

set voip profile [1 - 4] sip-advanced-setting sip-timer-b-value 32000

Assigns a SIP B timer (INVITE transaction timeout) value to the profile.

set voip profile [1 - 4] sip-advanced-setting sip-timer-c-value 0

Assigns a SIP C timer value to the profile.

set voip profile [1 - 4] sip-advanced-setting sip-timer-d-value 32000

Assigns a SIP D timer (response retransmission time) value to the profile.

set voip profile [1 - 4] sip-advanced-setting sip-timer-e-value 500

Assigns a SIP E timer (UDP NON-INVITE retransmit interval) value to the profile.

set voip profile [1 - 4] sip-advanced-setting sip-timer-f-value 32000

Assigns a SIP F timer (NON-INVITE retransmit interval) value to the profile.

set voip profile [1 - 4] sip-advanced-setting sip-timer-g-value 500

Assigns a SIP G timer (INVITE response retransmit interval) value to the profile.

set voip profile [1 - 4] sip-advanced-setting sip-timer-h-value 32000

Assigns a SIP H timer (ACK receipt wait time) value to the profile.

set voip profile [1 - 4] sip-advanced-setting sip-timer-i-value 5000

Assigns a SIP I timer (ACK retransmit wait time) value to the profile.

set voip profile [1 - 4] sip-advanced-setting sip-timer-j-value 32000

Assigns a SIP J timer (non-INVITE retransmit request wait time) value to the profile.

set voip profile [1 - 4] sip-advanced-setting sip-timer-k-value 0

Assigns a SIP K timer (response retransmission wait time) value to the profile.

set voip profile [1 - 4] sip-advanced-setting sip-reset-code "code"

Sets the SIP reset code for the profile. Default: 101

set voip profile [1 - 4] sip-advanced-setting sip-timer-shortinterdigit-value [value]

Sets an interdigit (short) timer value for the profile. Default: 0

set voip profile [1 - 4] sip-advanced-setting sip-timer-interdigit-value [value]

Sets an interdigit timer value to the profile. Default: 0.

set voip profile [1 - 4] rtp-advanced-setting rtp-qos-tos [value]

Assigns a Real Time Protocol terms of service number code to the VoIP profile. Default: 184.

set voip profile [1 - 4] rtp-advanced-setting rtp-qos-p-bit [0 - 7]

Sets a Real Time Protocol Priority bit (P-bit) value to the VoIP profile. Default: 6.

set voip profile [1 - 4] rtp-advanced-setting rtp-qos-marker "string"

Assigns a Real Time Protocol QoS packet marker to the VoIP profile. Default "VO".

set voip profile [1 - 4] rtp-advanced-setting rtp-port-range-start [value]

Defines the beginning of the VoIP Real Time Protocol port range assigned to the profile. Default: 6002.

set voip profile [1 - 4] rtp-advanced-setting rtp-port-range-end [value]

Defines the end of the VoIP Real Time Protocol port range assigned to the profile. Default: 6200.

set voip profile [1 - 4] rtp-advanced-setting rtcp-option [on | off]

Configures the Real Time Control Protocol (RTCP) setting for the VoIP profile.

set voip profile [1 - 4] rtp-advanced-setting rtcp-repeat-interval [value]

Assigns a Real Time Control Protocol repeat interval value to the VoIP RTP profile. Default: 5000

set voip profile [1 - 4] advanced-telephony-setting fxs-port-setting-for-fxo [none | fxs1 | fxs2 | both | emgncy]

Sets a port to be used for the FXS (Foreign eXchange Subscriber interface) port to the FXO (Foreign eXchange Office interface -- the phone) port. Default is **none**.

set voip profile [1 - 4] advanced-telephony-setting t38-option [on | off]

Enables or disables T.38 fax capability for the VoIP profile.

set voip profile [1 - 4] advanced-telephony-setting sip-dynamic-line-selection [on | off]

Turns dynamic (next available) line selection off or on for the identified VoIP profile. Default is **off**.

set voip profile [1 - 4] advanced-telephony-setting sip-dns-ns [on | off]

Enable or disable SIP DNS NS records (for Authoritative Name Server zone specification).

set voip profile [1 - 4] advanced-telephony-setting sip-dns-naptr [on | off]

Enable or disable the Name Authority Pointer (NAPTR) DNS function in the SIP profile.

set voip profile [1 - 4] advanced-telephony-setting sip-dns-srv [on | off]

Enable or disable the use of DNS Service Locator (SRV) functions in the profile.

set voip profile [1 - 4] advanced-telephony-setting testline-setting voip-testline-mode Always

Assign a line test mode to the VoIP profile specified.

set voip profile [1 - 4] advanced-telephony-setting testline-setting voip-testline-maxlenX5s [value]

Set the maximum X5s length to the profile's testline settings. Default: 6

set voip profile [1 - 4] advanced-telephony-setting testline-setting voip-testline-maxfreq [value]

Set the maximum frequency of line tests for the VoIP profile. Default: 10

set voip profile [1 - 4] user-account [1 - 4] enable [on | off]

Enables or disables the identified VoIP user account (individual account) on the specified VoIP profile.

**NOTE:**

User account settings may be specified for disabled user accounts, but the features will not be available unless the account is enabled.

set voip profile [1 - 4] user-account [1 - 4] voip-testline-option [on | off]

Enable or disable the test line option for the named user account on the VoIP profile. Default: off.

set voip profile [1 - 4] user-account [1 - 4] fxs-line 1

Sets a line in the user account to support FXS (Foreign eXchange Subscriber interface). Default is **none**.

set voip profile [1 - 4] user-account [1 - 4] sip-user-disp-name "[string]"

Assigns a display name for the identified user account on the specified VoIP profile. Default: "1000"=

set voip profile [1 - 4] user-account [1 - 4] sip-user-name "[string]"

Adds a user name value to the VoIP profile SIP user account. Default: "1000"

set voip profile [1 - 4] user-account [1 - 4] sip-user-password "[string]"

Sets the SIP password for the user account on the VoIP profile.

set voip profile [1 - 4] user-account [1 - 4] sip-user-auth-id "[string]"

Defines a user authentication ID value for the user account on the VoIP profile. Default: "1000"

set voip profile [1 - 4] user-account [1 - 4] sip-uri ""

Assigns a SIP Uniform Resource Identifier (URI) to the specified user account.

set voip profile [1 - 4] user-account [1 - 4] sip-subscribe-expires [time]

Sets the expiration timer value for SIP subscriptions by the identified user account. Default: 3600

set voip profile [1 - 4] user-account [1 - 4] sip-service-outage-detect [on | off]

Enables or disables the detection of SIP service outages by the user account.

set voip profile [1 - 4] user-account [1 - 4] codec G711U priority [1 - 7 | none]

Assigns a priority value to the mu-law (G711U) codec on the user account. Default: 1

set voip profile [1 - 4] user-account [1 - 4] codec G711U packetization-time [value]

Assigns a packetization time value to the mu-law (G711U) codec on the user account. Default: 20

set voip profile [1 - 4] user-account [1 - 4] codec G711A priority [1 - 7 | none]

Assigns a priority value to the a-law (G711A) codec on the user account. Default: 2

set voip profile [1 - 4] user-account [1 - 4] codec G711A packetization-time [value]

Assigns a packetization time value to the a-law (G711A) codec on the user account. Default: 20

set voip profile [1 - 4] user-account [1 - 4] codec G729 priority [1 - 7 | none]

Assigns a priority value to the G.729 codec on the user account. Default: 7

set voip profile [1 - 4] user-account [1 - 4] codec G729 packetization-time [value]

Assigns a packetization time value to the G.729 codec on the user account. Default: 20

set voip profile [1 - 4] user-account [1 - 4] codec G729 annexb-support [on | off]

Enables or disabled G.729 Annex-B support on the specified user account. Default: off.

set voip profile [1 - 4] user-account [1 - 4] codec G726_16 priority [1 - 7 | none]

Assigns a priority value to the 16 kbit/s G.726 codec on the user account. Default: 3.

set voip profile [1 - 4] user-account [1 - 4] codec G726_16 payload-type [value]

Assigns a payload value to the 16 kbit/s G.726 codec on the user account. Default: 102.

set voip profile [1 - 4] user-account [1 - 4] codec G726_16 packetization-time [value]

Assigns a packetization time value to the 16 kbit/s G.726 codec on the user account. Default: 20

set voip profile [1 - 4] user-account [1 - 4] codec G726_24 priority [1 - 7 | none]

Assigns a priority value to the 24 kbit/s G.726 codec on the user account. Default: 4

set voip profile [1 - 4] user-account [1 - 4] codec G726_24 payload-type [value]

Assigns a payload value to the 24 kbit/s G.726 codec on the user account. Default: 103

set voip profile [1 - 4] user-account [1 - 4] codec G726_24 packetization-time [value]

Assigns a packetization time value to the 24 kbit/s G.726 codec on the user account. Default: 20

set voip profile [1 - 4] user-account [1 - 4] codec G726_32 priority [1 - 7 | none]

Assigns a priority value to the 32 kbit/s G.726 codec on the user account. Default: 5.

set voip profile [1 - 4] user-account [1 - 4] codec G726_32 packetization-time [value]

Assigns a packetization time value to the 32 kbit/s G.726 codec on the user account. Default: 20

set voip profile [1 - 4] user-account [1 - 4] codec G726_40 priority [1 - 7 | none]

Assigns a priority value to the 40 kbit/s G.726 codec on the user account. Default: 6.

set voip profile [1 - 4] user-account [1 - 4] codec G726_40 payload-type [value]

Assigns a payload value to the 40 kbit/s G.726 codec on the user account. Default: 105.

set voip profile [1 - 4] user-account [1 - 4] codec G726_40 packetization-time [value]

Assigns a packetization time value to the 40 kbit/s G.726 codec on the user account. Default: 20

set voip profile [1 - 4] user-account [1 - 4] codec AMR priority [1 - 7 | none]

Assigns a priority value to the Adaptive Multi-Rate (AMR) - Narrowband audio codec on the user account. Default: none.

set voip profile [1 - 4] user-account [1 - 4] codec AMR payload-type [value]

Assigns a payload value to the AMR codec on the user account. Default: 120,

set voip profile [1 - 4] user-account [1 - 4] codec AMR packetization-time [value]

Assigns a packetization time value to the AMR codec on the user account. Default: 20

set voip profile [1 - 4] user-account [1 - 4] codec AMR_WB priority [1 - 7 | none]

Assigns a priority value to the Adaptive Multi-Rate - Wide Band (AMR-WB) audio codec on the user account. Default: none.

set voip profile [1 - 4] user-account [1 - 4] codec AMR_WB payload-type [value]

Assigns a payload value to the AMR-WB codec on the user account. Default: 122,

set voip profile [1 - 4] user-account [1 - 4] codec AMR_WB packetization-time [value]

Assigns a packetization time value to the AMR-WB codec on the user account. Default: 20

**set voip profile [1 - 4] user-account [1 - 4] call-feature
call-forwarding-all-option [on | off]**

Turns unconditional call forwarding on or off for the specified user account.

**set voip profile [1 - 4] user-account [1 - 4] call-feature
call-forwarding-on-busy-option [on | off]**

Enables or disables call forwarding when the line is busy for the specified user account.

set voip profile [1 - 4] user-account [1 - 4] call-feature

call-forwarding-on-no-answer-option [on | off]

Turns no-answer call forwarding on or off for the specified user account.

set voip profile [1 - 4] user-account [1 - 4] call-feature call-waiting-option [on | off]

Enables or disables call waiting for the specified user account.

set voip profile [1 - 4] user-account [1 - 4] call-feature call-conferencing-option [on | off]

Enables or disables 3-way conferencing for the user account.

set voip profile [1 - 4] user-account [1 - 4] call-feature do-not-disturb-option [on | off]

Activates or deactivates the ring-prevention (do not disturb) option for the specified user account.

set voip profile [1 - 4] user-account [1 - 4] call-feature subscribe-mwi-option [on | off]

Enables or disables the message waiting indicator for the user account.

set voip profile [1 - 4] user-account [1 - 4] call-feature subscribe-send-message [on | off]

Enables or disables message sending for the user account.

set voip profile [1 - 4] user-account [1 - 4] call-feature anonymous-call-block-option [on | off]

Sets the user account to block (on) or accept (off) calls from unidentified sources.

set voip profile [1 - 4] user-account [1 - 4] call-feature call-transfer-option [on | off]

Enables or disables the call transfer function on the user account.

set voip profile [1 - 4] user-account [1 - 4] call-feature call-disconn-supervision-option [on | off]

Enables or disabled disconnection supervision on the user account.

set voip profile [1 - 4] user-account [1 - 4] call-feature call-osi-signaldur [value]

Assigns an OSI signal duration value to the account. Default: 800.

set voip profile [1 - 4] user-account [1 - 4] dsp-settings echo-option [echo-off | echo-on | echo-on-nlp | echo-on-cng-nlp]

Specifies the conditions under which the user account will invoke or disable echo cancellation. Default: echo-on-cng-nlp

set voip profile [1 - 4] user-account [1 - 4] dsp-settings echo-tail-length 0

Specifies the length of the Digital Signal Processor (DSP) echo tail in milliseconds. Default: 0.

set voip profile [1 - 4] user-account [1 - 4] dsp-settings vad-option [on | off]

Enables or disables Voice Activity Detection (VAD) in the DSP for the user account.

Targeted Ad Insertion commands

set targeted-ad-insertion enable [on | off]

Turns targeted ad insertion on or off. Default is **on**.

set targeted-ad-insertion v-zone-ad [on | off]

Specifies whether the targeted ad is zone-specific. Default is **on**.

set targeted-ad-insertion sender-ssrc [0... n]

Specifies the synchronization source identifier for the sender.

set targeted-ad-insertion carousel-ip-address *ip_address*

Specifies the IP address of the ad carousel server.

set targeted-ad-insertion carousel-port [0... n]

Specifies the port of the ad carousel server.

set targeted-ad-insertion vcc-group-id [0... n]

Specifies the VCC group identifier of the ad carousel server.

set targeted-ad-insertion key-identification-counter [0... n]

Sets a counter value for the ad key identifier.

set targeted-ad-insertion authentication-key *string*

Specifies an authentication key for the targeted ads.

set targeted-ad-insertion channel-change-notification [on | off]

Turns the “change the channel” notification on or off. Default is **on**.

set targeted-ad-insertion retransmit [on | off]

Turns ad retransmission on or off. Default is **on**.

set targeted-ad-insertion unicast-filter [on | off]

Turns unicast filtering on or off. Default is **on**.

set targeted-ad-insertion blocked-unicast-sources *string*

Specifies names of unicast targeted ad sources to be blocked.

set targeted-ad-insertion hello-interval *seconds*

Specifies an interval for ad insertion in seconds. Default is 7200 (2 hours).

set targeted-ad-insertion hello-retransmit-min *seconds*

Specifies a minimum interval for retransmission of ad insertion in seconds. Default is 15 seconds.

set targeted-ad-insertion hello-retransmit-max *seconds*

Specifies a maximum interval for retransmission of ad insertion in seconds. Default is 300 seconds.

set targeted-ad-insertion vcc-ip-address *ip_address*

Specifies the VCC IP address of the ad carousel server.

set targeted-ad-insertion vcc-port [0... n]

Specifies the VCC port of the ad carousel server.

set targeted-ad-insertion zones *zone_number*

Specifies the zone for targeted ads when **v-zone-ad** is set to **on**.

set targeted-ad-insertion during-ad-timeout *value*

Sets a timeout value. Default is 25,000.

System commands

set system name *name*

Specifies the name of your ARRIS® Gateway. Each ARRIS® Gateway is assigned a name as part of its factory initialization. The default name for a ARRIS® Gateway consists of the word “ARRIS-7000/XXX” where “XXX” is the serial number of the device; for example, ARRIS-7000/9437188. A system name can be 1 – 255 characters long. Once you have assigned a name to your ARRIS® Gateway, you can enter that name in the Address text field of your browser to open a connection to your ARRIS® Gateway.



NOTE:

Some broadband cable-oriented Service Providers use the System Name as an important identification and support parameter. If your Gateway is part of this type of network, do NOT alter the System Name unless specifically instructed by your Service Provider.

set system time-zone [UTC | HST10 | AKST9AKDT | YST8 | PST8PDT | MST7MDT | MST7 | CST6CDT | CST6 | EST5EDT | AST4ADT | NST3:30NDT]

time-zone of 0 is Coordinated Universal Time (UTC); options are -12 through 12 (+/- 1 hour increments from UTC time).

set system auto-daylight-savings [on | off]

Time zones honoring Daylight Saving Time may be automatically designated.

set system firewall-log enable [on | off]

Turns firewall logging on or off. The firewall log tracks attempted violations of the firewall rules. Default is **on**.

set system firewall-log persist [on | off]

When set to **on**, causes the log information to be kept in flash memory. Default is **off**.

set system firewall-log file-size [4096... 65536]

Specifies a size for the firewall logs. The most recent entries are posted to the beginning of the log. When the log becomes full, the oldest entries are dropped. The default is 16384.

set system firewall-log file-count [2... 8]

Specifies the number of possible log files. The default is 4.

set system fastpath software-enable [on | off]

Enables or disables the fastpath accelerator processor. Fastpath works on only TCP and UDP. Default is **on**.

set system fastpath hardware-enable [off | on]

Enables or disables the fastpath accelerator processor. Default is **off**.

set system fastpath mcast-mode 3

Sets the mode for multicast on the fastpath accelerator processor.

set system scheduler enable [off | on]

Turns the system scheduler feature on or off. The default is **off**.

set system scheduler enable-time *hr:min*

Specifies a time at which to turn the system on. Default is midnight (00:00). **enable-time** must be supplied in 24 hour military time, colon separated, for example "05:21".

set system scheduler disable-time *hr:min*

Specifies a time at which to turn the system off. Default is 5 o'clock (05:00). **disable-time** must be supplied in 24 hour military time, colon separated, for example "21:44".

set system calendar-update enable [on | off]

Turns the calendar update feature on or off. The device will periodically poll the update server for new operating system software. The default is **on**.

set system calendar-update interval [monthly | biweekly]

Specifies how often the device should poll the update server, monthly or biweekly. The default is **monthly**.

set system calendar-update protocol [http | https | tftp]

Specifies the protocol for accessing the update server. The default is **http**.

set system calendar-update server *server_address*

Specifies the address of the update server by name or IP address. The default is "cpems.bellsouth.net".

set system calendar-update username *string*

Specifies the username for the update server. The default is "anonymous".

set system calendar-update password *string*

Specifies the password for the update server. The default is "guest".

set system calendar-update fwverfile *filename*

Specifies the firmware version filename to the update server. For the AT&T NVG595 the file is "netopiaNVG595_64.txt".

set system calendar-update day *day_of_month*

Specifies the numerical day of the month for the update server to be polled, for example, "21".

set system calendar-update time *hr:min_AMP*

Specifies the time of day for the update server to be polled, in the form HOUR:MINUTEAM/PM. Example: "06:00AM"

set system supplicant enable [on | off]

Turns on the 802.1x supplicant functionality. You must set the corresponding "type" field in the WAN link to activate it:

```
NOS/142253966608 (top)>> set link name WAN supplicant
    supplicant
      type (none) [ none | eap-tls ]:
      priority (0) [ 0 - 7 ]:
```

Default is **on**.

set system supplicant dest-broadcast [off | on]

Mostly useful for debugging. If this is set to **on**, the destination MAC address FF:FF:FF:FF:FF:FF is used when the supplicant sends 802.1x packets. If this is **off**, the EAPOL-specific destination address of 01:80:C2:00:00:03 is used. Default is **off**.

set system supplicant eap-tls-identity *string*

Sets the identity sent by the supplicant in response to an Identity request from an 802.1x authenticator.

set system supplicant server-cert-check [on | off]

If set to **on**, examines the certificate chain sent by an 802.1x authenticator for validation, and ensures that the root cert of this chain is accepted by the CPE (i.e. in its trust list). Default is **on**.

set system supplicant tagging-enable [off | on]

Disable or enable VLAN tagging on the WAN port.

set system syslog enable [on | off]

Enables (on) or disables (off) the NVG595 syslog function. The syslog function is disabled by default. If syslog is enabled, the following additional syslog settings may be configured:

- ◆ [set system syslog server-ip <IPv4/IPv6 Address>](#)
- ◆ [set system syslog server-port <port>](#)
- ◆ [set system syslog facility \[local0 ... local7 \]](#)
- ◆ [set system syslog level \[0 ... 7 \]](#)
- ◆ [set system syslog log-system \[on | off \]](#)
- ◆ [set system syslog log-firewall \[on | off \]](#)
- ◆ [set system syslog log-igmp \[on | off \]](#)
- ◆ [set system syslog log-voice \[on | off \]](#)

You must specify the syslog server's IP address and any custom UDP port number to identify system logging messages with the [set system syslog server-ip <IPv4/IPv6 Address>](#) and [set system syslog server-port <port>](#) commands. After the syslog server is specified, you may turn on any or all of the logging categories.

The receiving server must have a properly configured syslog server package active.

set system syslog server-ip <IPv4/IPv6 Address>

Specifies the IP address (in IPv4 dotted decimal notation or IPv6 colon-separated hexadecimal notation) of the server that syslog messages will be sent to.

set system syslog server-port <port>

Customizes the UDP port number that the syslog function marks messages to the logging server package with (range: 1 - 65535, default: 514).

set system syslog facility [local0 ... local7]

Specifies the local facility number that syslog messages are sent to (range: local0 - local7, default: local0).

set system syslog level [0 ... 7]

Sets the severity level of syslog messages the NVG595 will send to the syslog server. Each severity level includes all higher-level messages (e.g; a level of 2 [Critical] will also send Alert and Emergency messages) . The severity levels are arranged and enumerated as follows:

- ◆ 0 : Emergency
 - ◆ 1 : Alert
 - ◆ 2 : Critical
 - ◆ 3 : Error
 - ◆ 4 : Warning
 - ◆ 5 : Notice (default)
 - ◆ 6 : Info
 - ◆ 7 : Debug
-

set system syslog log-system [on | off]

Enables (on) or disables (off) the generation of system log messages for the syslog server. If the syslog function is enabled, system log is enabled (on) by default.

set system syslog log-firewall [on | off]

Enables (on) or disables (off) the delivery of firewall log messages to the syslog server. Firewall log is disabled by default.

set system syslog log-igmp [on | off]

Enables (on) or disables (off) the delivery of IGMP log messages to the syslog server. The igmp log is disabled by default.

set system syslog log-voice [on | off]

Enables (on) or disables (off) the generation of voice log messages for the syslog server. Voice log is disabled by default.

set system voice-check enable [off | on]

When this is set to **on**, and a voice call is in progress when a software update is scheduled, the software update is deferred for the **voice-check interval** until the call is completed, that is, the call state becomes "idle." If set to **off**, and a voice call is in progress when an update is scheduled, the call is torn down. The default is **on**.

set system voice-check interval [60 - 86400]

This specifies the interval in seconds for the device to wait before attempting a software update, when a software update is scheduled but a voice call is in progress, when **voice-check enable** is set to **on**. The default is **300** (5 minutes).

set system voice-check max-time [300 - 604800]

This specifies the maximum time in seconds for the device to continue to attempt a scheduled software update if a voice call is in progress and **voice-check enable** is set to **on**. The default is **3600** (1 hour).

set system log buffer-size [4096... 65536]

Specifies a size for the system log. The most recent entries are posted to the beginning of the log. When the log becomes full, the oldest entries are dropped. The default is 16384.

set system log level [low | medium | high | alerts | failures]

Specifies the types of log messages you want the ARRIS® Gateway to record. All messages with a level equal to or greater than the level you specify are recorded. For example, if you specify **set system diagnostic-level medium**, the diagnostic log will retain medium-level informational messages, alerts, and failure messages.

Use the following guidelines:

- ◆ **low** - Low-level informational messages or greater; includes trivial status messages.
- ◆ **medium** - Medium-level informational messages or greater; includes status messages that can help monitor network traffic.
- ◆ **high** - High-level informational messages or greater; includes status messages that may be significant but do not constitute errors. The default.
- ◆ **alerts** - Warnings or greater; includes recoverable error conditions and useful operator information.
- ◆ **failures** - Failures; includes messages describing error conditions that may not be recoverable.

Debug Commands

When you are in SHELL mode, the DEBUG prompt is the name of the ARRIS® Gateway/DEBUG followed by a right angle bracket (>). For example, if you open a CLI connection to the ARRIS® Gateway named "ARRIS-3000/9437188," then type "debug" you would see **ARRIS-3000/9437188/DEBUG>** as your prompt.

Debug level is available for field debugging purposes. There is no service and quality level guarantee from ARRIS. This level is intended for SEs or Telcos lab people, not for normal operation at home for end users.

More commands are available. To display the options, type "**help all**".

Disclaimer & Warning Text

The following is displayed when entering Debug level from normal Config level.

"Warning: Accessing these commands may impact the normal operation of this device. Exit now if you entered by mistake."

Commands

console

Make this session the console.

mirror <src-port> <dst-port>

To mirror one port's traffic to another. Causes traffic transmitted or received on <src-port> to be mirrored on <dst-port>. Ports must support Ethernet (IPoA and PPPoA ATM ports are not supported).

mirror off

Turns off port mirroring.

show fastpath

Displays entries in fastpath.

show cpu

Displays CPU Usage as a percentage and CPU Load Averages over 1, 5 and 15 minute periods.

CLI CShell Commands (debug mode)

```
tr69 GetParameterValues <path>
tr69 SetParameterValues <path> = <value>
tr69 GetParameterNames <path> <nextlevel>
tr69 Addobject <path>
tr69 Deleteobject <path>
```

Example:

```
tr69 GetParameterValues InternetGatewayDevice.
```



NOTE:

CLI and ACS sessions are mutually exclusive and should not be used at the same time

CHAPTER 5 Technical Specifications and Safety Information

Description

Dimensions: 1.8 in H x 8.2 in W x 6.5 in D (4.5 cm H x 20.8 cm W x 16.6 cm D)

Weight: 1.0 lb

Communications interfaces: The ARRIS® Gateways have a 4-port 10/100/1000Base-T Ethernet switch for your LAN connections, an FXS port for VoIP connections, and a high power, selectable 2.4 or 5 Ghz Wi-Fi radio for Wi-Fi connections.

WAN interfaces: One-port Fiber SFP cage with support for both LX and SX connectors ; One-port 10/100/1000 Ethernet, RJ-45

Power Supply

115VAC 24W/12VDC@2.0A (2phone,5REN, RINGING)

Environment

Operating temperature: 0°C to 42°C (32° F to 107° F); 8% to 95% (Non Condensing) Relative Humidity

Storage temperature: -20° C to 85° C (-4° F to 185° F)

Relative storage humidity: 20 to 80% noncondensing

Software and protocols

Software media: Software preloaded on internal flash memory; field upgrades done via download to internal flash memory via CLI or web upload.

Routing: IPv4 , IPv6/6rd; DHCP server/relay; DNS Proxy, Dynamic DNS Support; Multiple subnet support

WAN support: PPPoA, DHCP, static IP address; Security:

Stateful Packet Inspection Firewall; Virtual DMZ/IP pass-through; Denial of Service (DoS) protection; VPN Pass-through (PPTP, L2TP, IPSec)

Wi-Fi Security. WEP (64-bit, 128-bit, 256-bit) encryption 802.1x, WPA, WPA-PSK, 802.11i/WPA2, WPA2-PSK EAP-TLS, EAP-TTLS, EAP-SIM MAC Address filtering

Management/configuration methods: HTTP (Web server), TR-069

Diagnostics: Ping, event logging, routing table displays, statistics counters, web-based management, traceroute, nslookup, and diagnostic commands.

Agency approvals

North America

Safety Approvals:

- ◆ United States – UL 60950, Third Edition
- ◆ Canada – CSA: CAN/CSA-C22.2 No. 60950-00

EMC:

- ◆ United States – FCC Part 15 Class B
- ◆ Canada – ICES-003

Telecom:

- ◆ United States – 47 CFR Part 68
- ◆ Canada – CS-03

Manufacturer's Declaration of Conformance

**WARNING:**

This is a Class B product. In a domestic environment this product may cause radio interference, in which case the user may be required to take adequate measures. Adequate measures include increasing the physical distance between this product and other electrical devices.

Changes or modifications to this unit not expressly approved by the party responsible for compliance could void the user's authority to operate the equipment.

United States. This device complies with Part 15 of the FCC Rules. Operation is subject to the following two conditions: (1) This device may not cause harmful interference, and (2) this device must accept any interference received, including interference that may cause undesired operation.

This equipment has been tested and found to comply with the limits for a Class B digital device, pursuant to Part 15 of the FCC Rules. These limits are designed to provide reasonable protection against harmful interference in a residential installation. This equipment generates, uses and can radiate radio frequency energy and, if not installed and used in accordance with the instructions, may cause harmful interference to radio communications. However, there is no guarantee that interference will not occur in a particular installation. If this equipment does cause harmful interference to radio or television reception, which can be determined by turning the equipment off and on, the user can try to correct the interference using one of the following measures:

- ◆ Reorient or relocate the receiving antenna.
- ◆ Increase the separation between the equipment and receiver.
- ◆ Connect the equipment into an outlet on a circuit different from that to which the receiver is connected.
- ◆ Consult the dealer or an experienced radio TV technician for help.

This device complies with Part 15 of the FCC Rules. Operation is subject to the following two conditions:

- 1. This device may not cause harmful interference, and**
- 2. this device must accept any interference received, including interference that may cause undesired operation.**

This transmitter must not be co-located or operating in conjunction with any other antenna or transmitter.

Operation within the 5.15 ~ 5.25GHz band is restricted to an indoor environment.

FOR MOBILE DEVICE USAGE . (>20cm/low power)

Radiation Exposure Statement:

This equipment complies with FCC radiation exposure limits as set forth for an uncontrolled environment. This equipment should be installed and operated maintaining a minimum distance of 20cm between the device and the user.

FCC Caution: Any changes or modifications not expressly approved by the party responsible for compliance could void the user's authority to operate this equipment.

FOR COUNTRY CODE SELECTION USAGE (WLAN DEVICES).

**NOTE:**

The country code selection is for non-US models only and is not available to all US models. Per FCC regulation, all WiFi products marketed in the United States must be set to US operation channels only.

Service requirements. In the event of equipment malfunction, if under warranty we will exchange a product deemed defective. Under FCC rules, no customer is authorized to repair this equipment. This restriction applies regardless of whether the equipment is in or out of warranty.

Technical Support for Hardware Products

1-877-466-8646

<http://www.arrisi.com/support>



IMPORTANT:

This product was tested for FCC compliance under conditions that included the use of shielded cables and connectors between system components. Changes or modifications to this product not authorized by the manufacturer could void your authority to operate the equipment.

. CANADA:

NOTICE: This equipment meets the applicable Industry Canada Terminal Equipment Technical Specifications. This is confirmed by the registration number. The abbreviation, IC, before the registration number signifies that registration was performed based on a Declaration of Conformity indicating that Industry Canada technical specifications were met. It does not imply that Industry Canada approved the equipment.

NOTICE: The Ringer Equivalence Number (REN) for this terminal equipment is 0.1. The REN assigned to each terminal equipment provides an indication of the maximum number of terminals allowed to be connected to a telephone interface. The termination on an interface may consist of any combination of devices subject only to the requirement that the sum of the Ringer Equivalence Numbers of all the devices does not exceed five.

AVIS : Le présent matériel est conforme aux spécifications techniques d'Industrie Canada applicables au matériel terminal. Cette conformité est confirmée par le numéro d'enregistrement. Le sigle IC, placé devant le numéro d'enregistrement, signifie que l'enregistrement s'est effectué conformément à une déclaration de conformité et indique que les spécifications techniques d'Industrie Canada ont été respectées. Il n'implique pas qu'Industrie Canada a approuvé le matériel.

AVIS : L'indice d'équivalence de la sonnerie (IES) du présent matériel est de 0.1. L'IES assigné à chaque dispositif terminal indique le nombre maximal de terminaux qui peuvent être raccordés à une interface téléphonique. La terminaison d'une interface peut consister en une combinaison quelconque de dispositifs, à la seule condition que la somme d'indices d'équivalence de la sonnerie de tous les dispositifs n'excède pas 5.

Canada. This Class B digital apparatus meets all requirements of the Canadian Interference -Causing Equipment Regulations.

Cet appareil numérique de la classe B respecte toutes les exigences du Règlement sur le matériel brouilleur du Canada.

Declaration for Canadian users

NOTICE: The Canadian Industry Canada label identifies certified equipment. This certification means that the equipment meets certain telecommunications network protective, operation, and safety requirements. The Department does not guarantee the equipment will operate to the user's satisfaction.

Before installing this equipment, users should ensure that it is permissible to be connected to the facilities of the local telecommunications company. The equipment must also be installed using an acceptable method of connection. In some cases, the company's inside wiring associated with a single line individual service may be extended by means of a certified connector assembly (telephone extension cord). The customer should be aware that compliance with the above conditions may not prevent degradation of service in some situations.

Repairs to the certified equipment should be made by an authorized Canadian maintenance facility designated by the supplier. Any repairs or alterations made by the user to this equipment, or equipment malfunctions, may give the telecommunications company cause to request the user to disconnect the equipment.

Users should ensure for their own protection that the electrical ground connections of the power utility, telephone lines, and internal metallic water pipe system, if present, are connected together. This precaution may be particularly important in rural areas.

Caution

Users should not attempt to make such connections themselves, but should contact the appropriate electric inspection authority, or electrician, as appropriate.

The Ringer Equivalence Number (REN) assigned to each terminal device provides an indication of the maximum number of terminals allowed to be connected to a telephone interface. The termination on an interface may consist of any combination of devices subject only to the requirement that the sum of the Ringer Equivalence Numbers of all the devices does not exceed 5.

Important Safety Instructions

Caution

DO NOT USE BEFORE READING THE INSTRUCTIONS: Do not connect the Ethernet ports to a carrier or carriage service provider's telecommunications network or facility unless: a) you have the written consent of the network or facility manager, or b) the connection is in accordance with a connection permit or connection rules.

Connection of the Ethernet ports may cause a hazard or damage to the telecommunication network or facility, or persons, with consequential liability for substantial compensation.

Caution

- ◆ The direct plug-in power supply serves as the main power disconnect; locate the direct plug-in power supply near the product for easy access.
- ◆ For use only with CSA Certified Class 2 power supply, rated 12VDC, 1.0A.

Telecommunication installation cautions

- ◆ Never install telephone wiring during a lightning storm.
- ◆ Never install telephone jacks in wet locations unless the jack is specifically designed for wet locations.
- ◆ Never touch uninsulated telephone wires or terminals unless the telephone line has been disconnected at the network interface.
- ◆ Use caution when installing or modifying telephone lines.
- ◆ Avoid using a telephone (other than a cordless type) during an electrical storm. There may be a remote risk of electric shock from lightning.
- ◆ Do not use the telephone to report a gas leak in the vicinity of the leak.

47 CFR Part 68 Information

FCC Requirements

1. The Federal Communications Commission (FCC) has established Rules which permit this device to be directly connected to the telephone network. Standardized jacks are used for these connections. This equipment should not be used on party lines or coin phones.
2. If this device is malfunctioning, it may also be causing harm to the telephone network; this device should be disconnected until the source of the problem can be determined and until repair has been made. If this is not done, the telephone company may temporarily disconnect service.
3. The telephone company may make changes in its technical operations and procedures; if such changes affect the compatibility or use of this device, the telephone company is required to give adequate notice of the changes. You will be advised of your right to file a complaint with the FCC.
4. If the telephone company requests information on what equipment is connected to their lines, inform them of:
 - a. The telephone number to which this unit is connected.
 - b. The ringer equivalence number. [0.XB]
 - c. The USOC jack required. [RJ11C]
 - d. The FCC Registration Number. [XXXUSA-XXXX-XX-E]

Items (b) and (d) are indicated on the label. The Ringer Equivalence Number (REN) is used to determine how many devices can be connected to your telephone line. In most areas, the sum of the REN's of all devices on any one line should not exceed five (5.0). If too many devices are attached, they may not ring properly.

FCC Statements

a) This equipment complies with Part 68 of the FCC rules and the requirements adopted by the ACTA. On the bottom of this equipment is a label that contains, among other information, a product identifier in the format US:AAAEQ##TXXXX. If requested, this number must be provided to the telephone company.

b) List all applicable certification jack Universal Service Order Codes ("USOC") for the equipment: RJ11.

c) A plug and jack used to connect this equipment to the premises wiring and telephone network must comply with the applicable FCC Part 68 rules and requirements adopted by the ACTA. A compliant telephone cord and modular plug is provided with this product. It is designed to be connected to a compatible modular jack that is also compliant. See installation instructions for details.

d) The REN is used to determine the number of devices that may be connected to a telephone line. Excessive RENs on a telephone line may result in the devices not ringing in response to an incoming call. In most but not all areas, the sum of RENs should not exceed five (5.0). To be certain of the number of devices that may be connected to a line, as determined by the total RENs, contact the local telephone company. For products approved after July 23, 2002, the REN for this product is part of the product identifier that has the format US:AAAEQ##TXXXX. The digits represented by ## are the REN without a decimal point (e.g., 03 is a REN of 0.3). For earlier products, the REN is separately shown on the label.

e) If this equipment, the ARRIS® Gateway, causes harm to the telephone network, the telephone company will notify you in advance that temporary discontinuance of service may be required. But if advance notice isn't practical, the telephone company will notify the customer as soon as possible. Also, you will be advised of your right to file a complaint with the FCC if you believe it is necessary.

f) The telephone company may make changes in its facilities, equipment, operations or procedures that could affect the operation of the equipment. If this happens the telephone company will provide advance notice in order for you to make necessary modifications to maintain uninterrupted service.

g) If trouble is experienced with this equipment, the ARRIS® Gateway, for warranty information, please contact:

Technical Support for Hardware Products
1-877-466-8646
<http://www.ARRIS.com/support>

If the equipment is causing harm to the telephone network, the telephone company may request that you disconnect the equipment until the problem is resolved.

h) This equipment not intended to be repaired by the end user. In case of any problems, please refer to the troubleshooting section of the Product User Manual before calling ARRIS Technical Support.

i) Connection to party line service is subject to state tariffs. Contact the state public utility commission, public service commission or corporation commission for information.

j) If your home has specially wired alarm equipment connected to the telephone line, ensure the installation of this ARRIS® Series Gateway does not disable your alarm equipment. If you have questions about what will disable alarm equipment, consult your telephone company or qualified installer.

RF Exposure Statement:

NOTE: Installation of the Wi-Fi models must maintain at least 20 cm between the Wi-Fi Gateway and any body part of the user to be in compliance with FCC RF exposure guidelines.

Electrical Safety Advisory

Telephone companies report that electrical surges, typically lightning transients, are very destructive to customer terminal equipment connected to AC power sources. This has been identified as a major nationwide problem. Therefore it is advised that this equipment be connected to AC power through the use of a surge arrester or similar protection device.

Caring for the Environment by Recycling

When you see this symbol on a ARRIS product, do not dispose of the product with residential or commercial waste.



Recycling your ARRIS Equipment

Please do not dispose of this product with your residential or commercial waste. Some countries or regions, such as the European Union, have set up systems to collect and recycle electrical and electronic waste items. Contact your local authorities for information about practices established for your region. If collection systems are not available, call ARRIS Customer Service for assistance.

Please visit www.ARRIS.com/recycle

<<http://www.ARRIS.com/recycle>> for instructions on recycling.

Beskyttelse af miljøet med genbrug

Når du ser dette symbol på et ARRIS-produkt, må produktet ikke bortskaffes sammen med husholdningsaffald eller erhvervsaffald.

Genbrug af dit ARRIS-udstyr

Dette produkt må ikke bortskaffes sammen med husholdningsaffald eller erhvervsaffald. Nogle lande eller områder, f.eks. EU, har oprettet systemer til indsamling og genbrug af elektriske og elektroniske affaldsprodukter. Kontakt de lokale myndigheder for oplysninger om gældende fremgangsmåder i dit område. Hvis der ikke findes tilgængelige indsamlingssystemer, kan du kontakte ARRIS Kundeservice.

Umweltschutz durch Recycling

Wenn Sie dieses Zeichen auf einem Produkt von ARRIS sehen, entsorgen Sie das Produkt bitte nicht als gewöhnlichen Hausoder Büromüll.

Recycling bei Geräten von ARRIS

Bitte entsorgen Sie dieses Produkt nicht als gewöhnlichen Haus- oder Büromüll. In einigen Ländern und Gebieten, z. B. in der Europäischen Union, wurden Systeme für die Rücknahme und Wiederverwertung von Elektroschrott eingeführt. Erkundigen Sie sich bitte bei Ihrer Stadtoder Kreisverwaltung nach der geltenden Entsorgungspraxis. Falls bei Ihnen noch kein Abfuhroder Rücknahmesystem besteht, wenden Sie sich bitte an den Kundendienst von ARRIS.

Cuidar el medio ambiente mediante el reciclaje

Cuando vea este símbolo en un producto ARRIS, no lo deseche junto con residuos residenciales o comerciales.

Reciclaje de su equipo ARRIS

No deseche este producto junto con sus residuos residenciales o comerciales. Algunos países o regiones, tales como la Unión Europea, han organizado sistemas para recoger y reciclar desechos eléctricos y electrónicos. Comuníquese con las autoridades locales para obtener información acerca de las prácticas vigentes en su región. Si no existen sistemas de recolección disponibles, solicite asistencia llamando el Servicio al Cliente de ARRIS.

Recyclage pour le respect de l'environnement

Lorsque vous voyez ce symbole sur un produit ARRIS, ne le jetez pas avec vos ordures ménagères ou vos rebus d'entreprise.

Recyclage de votre équipement ARRIS

Veuillez ne pas jeter ce produit avec vos ordures ménagères ou vos rebus d'entreprise. Certains pays ou certaines régions comme l'Union Européenne ont mis en place des systèmes de collecte et de recyclage des produits électriques et électroniques mis au rebut. Veuillez contacter vos autorités locales pour vous informer des pratiques instaurées dans votre région. Si aucun système de collecte n'est disponible, veuillez appeler le Service clientèle de ARRIS qui vous apportera son assistance.

Milieubewust recycleren

Als u dit symbool op een ARRIS-product ziet, gooi het dan niet bij het huishoudelijk afval of het bedrijfsafval.

Dbá³oEç o Erodowisko - recykling

Produktów ARRIS oznaczonych tym symbolem nie nale y wyrzucaç do komunalnych pojemników na Êmieci.

Cuidando do meio ambiente através da reciclagem

Quando você ver este símbolo em um produto ARRIS, não descarte o produto junto com lixo

Var rädd om miljön genom återvinning

När du ser den här symbolen på en av ARRISs produkter ska du inte kasta produkten tillsammans med det vanliga avfallet.

リサイクルによる環境保護

モトローラ製品にこの記号が表示されている場合、製品を家庭または商業廃棄物として処分しないでください。

재활용으로 환경 보호하기

Motorola 제품에 이 표시가 있는 경우, 가정 또는 상업 폐기물과 함께 버리지 마십시오.

Uw ARRIS-materiaal recycleren.

Gooi dit product niet bij het huishoudelijk afval het of bedrijfsafval. In sommige landen of regio's zoals de Europese Unie, zijn er bepaalde systemen om elektrische of elektronische afvalproducten in te zamelen en te recycleren. Neem contact op met de plaatselijke overheid voor informatie over de geldende regels in uw regio. Indien er geen systemen bestaan, neemt u contact op met de klantendienst van ARRIS.

Recykling posiadanego sprz³tu ARRIS

Produktu nie nale y wyrzucaç do komunalnych pojemników na Êmieci. W niektórych krajach i regionach, np. w Unii Europejskiej, istniejà systemy zbierania i recyklingu sprz³tu elektrycznego i elektronicznego. Informacje o utylizacji tego rodzaju odpadów nale y uzyskaç od w³adz lokalnych. JeÊli w danym regionie nie istniejà systemy zbierania odpadów elektrycznych i elektronicznych, informacje o utylizacji nale y uzyskaç od biura obsługi klienta firmy ARRIS (ARRIS Customer Service).

Reciclagem do seu equipamento ARRIS

Não descarte este produto junto com o lixo residencial ou comercial. Alguns países ou regiões, tais como a União Européia, criaram sistemas para coletar e reciclar produtos eletroeletrônicos. Para obter informações sobre as práticas estabelecidas para sua região, entre em contato com as autoridades locais. Se não houver sistemas de coleta disponíveis, entre em contato com o Serviço ao Cliente da ARRIS para obter assistência.

Återvinning av din ARRIS-utrustning

Kasta inte denna produkt tillsammans med det vanliga avfallet. Vissa länder eller regioner, som t.ex. EU, har satt upp ett system för insamling och återvinning av el- och elektronikavfall. Kontakta dina lokala myndigheter för information om vilka regler som gäller i din region. Om det inte finns något insamlingssystem ska du kontakta ARRISs kundtjänst för hjälp.

モトローラ装置のリサイクル

本製品を家庭または商業廃棄物として処分しないでください。欧州連合などの国または地域によっては、電氣的・電子的廃棄物を収集およびリサイクルするシステムがあります。お住まいの地域で決められている方法についての情報は、地方自治体にお問い合わせください。収集システムがない場合、モトローラ・カスタマーサービスまでお問い合わせください。

Motorola 기기 재활용

이 제품을 가정용 또는 사업용 폐기물과 함께 버리지 마십시오. 유럽 유니온과 같은 일부 국가 또는 지역에서는 재활용 전기 전자 폐기물 항목을 수집하는 시스템이 구축되어 있습니다. 해당 지역에 구축되어 있는 절차에 관한 정보는 지역 관할당국에 연락하십시오. 수집 시스템이 존재하지 않는 경우, 도움을 받기 위해 Motorola 고객센터부으로 연락하십시오.

重复利用，保护环境

如果 Motorola 产品上具有这个标识，请勿将产品丢弃到家庭或商业垃圾中。

Motorola 设备的重复利用

请勿将本产品丢弃到家庭或商业垃圾中。某些国家或地区，例如欧盟，已经建立起回收和重复利用电气与电子废弃物的体系。请与当地相关机构联系，获取有关所在地区相关规定的信息。如果当地尚未建立回收体系，请致电 Motorola 客户服务以寻求帮助。

注意環保問題

在你看到產品上有Motorola的標誌時，請勿以住家或商用的廢棄物方式處置。

Motorola 設備的回收

請勿以住家或商用的廢棄物方式處置。某些國家或地區，如歐盟，已對廢棄的電器和電子產品制訂回收以及再利用體制。請與您所在地的管理機構諮詢相關規定。若您所在的地區並未設置回收機制，請電Motorola客服部諮詢相關事宜。

Please visit <http://www.ARRIS.com/recycle> for instructions on recycling.

Copyright Acknowledgments

Because ARRIS Mobility, LLC has included certain software source code in this product, ARRIS Mobility includes the following text required by the respective copyright holders:

Open Source Software Information

For instructions on how to obtain a copy of any source code being made publicly available by ARRIS Mobility related to software used in this ARRIS Mobility product you may send your request in writing to:

ARRIS Mobility, LLC.
OSS Management
2450 Walsh Avenue
Santa Clara, CA 95051
USA

The ARRIS Mobility website opensource.ARRIS.com also contains information regarding ARRIS Mobility's use of open source. ARRIS Mobility has created the opensource.ARRIS.com to serve as a portal for interaction with the software community-at-large.

This document contains additional information regarding licenses, acknowledgments and required copyright notices for open source packages used in this ARRIS Mobility product.

aiccu 2007.01.15

The SixXS License - <http://www.sixxs.net/>

Copyright (C) SixXS <info@sixxs.net>
All rights reserved.

Redistribution and use in source and binary forms, with or without modification, are permitted provided that the following conditions are met:

1. Redistributions of source code must retain the above copyright notice, this list of conditions and the following disclaimer.
2. Redistributions in binary form must reproduce the above copyright notice, this list of conditions and the following disclaimer in the documentation and/or other materials provided with the distribution.
3. Neither the name of SixXS nor the names of its contributors may be used to endorse or promote products derived from this software without specific prior permission.

THIS SOFTWARE IS PROVIDED BY SIXXS AND CONTRIBUTORS "AS IS" AND ANY EXPRESS OR IMPLIED WARRANTIES, INCLUDING, BUT NOT LIMITED TO, THE IMPLIED WARRANTIES OF MERCHANTABILITY AND FITNESS FOR A PARTICULAR PURPOSE ARE DISCLAIMED. IN NO EVENT SHALL SIXXS OR CONTRIBUTORS BE LIABLE FOR ANY DIRECT, INDIRECT, INCIDENTAL, SPECIAL, EXEMPLARY, OR CONSEQUENTIAL DAMAGES (INCLUDING, BUT NOT LIMITED TO, PROCUREMENT OF SUBSTITUTE GOODS OR SERVICES; LOSS OF USE, DATA, OR PROFITS; OR BUSINESS INTERRUPTION) HOWEVER CAUSED AND ON ANY THEORY OF LIABILITY, WHETHER IN CONTRACT, STRICT LIABILITY, OR TORT (INCLUDING NEGLIGENCE OR OTHERWISE) ARISING IN ANY WAY OUT OF THE USE OF THIS SOFTWARE, EVEN IF ADVISED OF THE POSSIBILITY OF SUCH DAMAGE.

ASN.1 object dumping code

Copyright (c) Peter Gutmann

c-ares async resolver library

<http://daniel.haxx.se/projects/c-ares/>

Original ares library by Greg Hudson, MIT

<ftp://athena-dist.mit.edu/pub/ATHENA/ares>

Copyright 1998 by the Massachusetts Institute of Technology.

Permission to use, copy, modify, and distribute this software and its documentation for any purpose and without fee is hereby granted, provided that the above copyright notice appear in all copies and that both that copyright notice and this permission notice appear in supporting documentation, and that the name of M.I.T. not be used in advertising or publicity pertaining to distribution of the software without specific, written prior permission. M.I.T. makes no representations about the suitability of this software for any purpose. It is provided "as is" without express or implied warranty.

dhcpcd - DHCP client daemon 5.5.0

Copyright (c) 2006-2010 Roy Marples <roy@marples.name>
All rights reserved

Redistribution and use in source and binary forms, with or without modification, are permitted provided that the following conditions are met:

1. Redistributions of source code must retain the above copyright notice, this list of conditions and the following disclaimer.
2. Redistributions in binary form must reproduce the above copyright notice, this list of conditions and the following disclaimer in the documentation and/or other materials provided with the distribution.

THIS SOFTWARE IS PROVIDED BY THE AUTHOR AND CONTRIBUTORS ``AS IS'' AND ANY EXPRESS OR IMPLIED WARRANTIES, INCLUDING, BUT NOT LIMITED TO, THE IMPLIED WARRANTIES OF MERCHANTABILITY AND FITNESS FOR A PARTICULAR PURPOSE ARE DISCLAIMED. IN NO EVENT SHALL THE AUTHOR OR CONTRIBUTORS BE LIABLE FOR ANY DIRECT, INDIRECT, INCIDENTAL, SPECIAL, EXEMPLARY, OR CONSEQUENTIAL DAMAGES (INCLUDING, BUT NOT LIMITED TO, PROCUREMENT OF SUBSTITUTE GOODS OR SERVICES; LOSS OF USE, DATA, OR PROFITS; OR BUSINESS INTERRUPTION) HOWEVER CAUSED AND ON ANY THEORY OF LIABILITY, WHETHER IN CONTRACT, STRICT LIABILITY, OR TORT (INCLUDING NEGLIGENCE OR OTHERWISE) ARISING IN ANY WAY OUT OF THE USE OF THIS SOFTWARE, EVEN IF ADVISED OF THE POSSIBILITY OF SUCH DAMAGE.

Copyright (c) ARRIS India Electronics

dhcp (dhcp-isc) 4.1.1-P1

Copyright © 2004-2011 by Internet Systems Consortium, Inc. ("ISC")

Copyright © 1995-2003 by Internet Software Consortium

Permission to use, copy, modify, and/or distribute this software for any purpose with or without fee is hereby granted, provided that the above copyright notice and this permission notice appear in all copies.

THE SOFTWARE IS PROVIDED "AS IS" AND ISC DISCLAIMS ALL WARRANTIES WITH REGARD TO THIS SOFTWARE INCLUDING ALL IMPLIED WARRANTIES OF MERCHANTABILITY AND FITNESS. IN NO EVENT SHALL ISC BE LIABLE FOR ANY SPECIAL, DIRECT, INDIRECT, OR CONSEQUENTIAL DAMAGES OR ANY DAMAGES WHATSOEVER RESULTING FROM LOSS OF USE, DATA OR PROFITS, WHETHER IN AN ACTION OF CONTRACT, NEGLIGENCE OR OTHER TORTIOUS ACTION, ARISING OUT OF OR IN CONNECTION WITH THE USE OR PERFORMANCE OF THIS SOFTWARE.

dhcpcd - DHCP client daemon 5.5.0

Copyright (c) 2006-2011 Roy Marples <roy@marples.name>
All rights reserved

Redistribution and use in source and binary forms, with or without modification, are permitted provided that the following conditions are met:

1. Redistributions of source code must retain the above copyright notice, this list of conditions and the following disclaimer.
2. Redistributions in binary form must reproduce the above copyright notice, this list of conditions and the following disclaimer in the documentation and/or other materials provided with the distribution.

THIS SOFTWARE IS PROVIDED BY THE AUTHOR AND CONTRIBUTORS ``AS IS'' AND ANY EXPRESS OR IMPLIED WARRANTIES, INCLUDING, BUT NOT LIMITED TO, THE IMPLIED WARRANTIES OF MERCHANTABILITY AND FITNESS FOR A PARTICULAR PURPOSE ARE DISCLAIMED. IN NO EVENT SHALL THE AUTHOR OR CONTRIBUTORS BE LIABLE FOR ANY DIRECT, INDIRECT, INCIDENTAL, SPECIAL, EXEMPLARY, OR CONSEQUENTIAL DAMAGES (INCLUDING, BUT NOT LIMITED TO, PROCUREMENT OF SUBSTITUTE GOODS OR SERVICES; LOSS OF USE, DATA, OR PROFITS; OR BUSINESS INTERRUPTION) HOWEVER CAUSED AND ON ANY THEORY OF LIABILITY, WHETHER IN CONTRACT, STRICT LIABILITY, OR TORT (INCLUDING NEGLIGENCE OR OTHERWISE) ARISING IN ANY WAY OUT OF THE USE OF THIS SOFTWARE, EVEN IF ADVISED OF THE POSSIBILITY OF SUCH DAMAGE.

dhcpcv6

Copyright (C) 1998-2004 WIDE Project.

All rights reserved.

Redistribution and use in source and binary forms, with or without modification, are permitted provided that the following conditions are met:

1. Redistributions of source code must retain the above copyright notice, this list of conditions and the following disclaimer.
2. Redistributions in binary form must reproduce the above copyright notice, this list of conditions and the following disclaimer in the documentation and/or other materials provided with the distribution.
3. Neither the name of the project nor the names of its contributors may be used to endorse or promote products derived from this software without specific prior written permission.

THIS SOFTWARE IS PROVIDED BY THE PROJECT AND CONTRIBUTORS ``AS IS" AND ANY EXPRESS OR IMPLIED WARRANTIES, INCLUDING, BUT NOT LIMITED TO, THE IMPLIED WARRANTIES OF MERCHANTABILITY AND FITNESS FOR A PARTICULAR PURPOSE ARE DISCLAIMED. IN NO EVENT SHALL THE PROJECT OR CONTRIBUTORS BE LIABLE FOR ANY DIRECT, INDIRECT, INCIDENTAL, SPECIAL, EXEMPLARY, OR CONSEQUENTIAL DAMAGES (INCLUDING, BUT NOT LIMITED TO, PROCUREMENT OF SUBSTITUTE GOODS OR SERVICES; LOSS OF USE, DATA, OR PROFITS; OR BUSINESS INTERRUPTION) HOWEVER CAUSED AND ON ANY THEORY OF LIABILITY, WHETHER IN CONTRACT, STRICT LIABILITY, OR TORT (INCLUDING NEGLIGENCE OR OTHERWISE) ARISING IN ANY WAY OUT OF THE USE OF THIS SOFTWARE, EVEN IF ADVISED OF THE POSSIBILITY OF SUCH DAMAGE.

Encryption

Aaron D. Gifford License

Copyright (c) 2000-2001, Aaron D. Gifford

All rights reserved.

Redistribution and use in source and binary forms, with or without modification, are permitted provided that the following conditions are met:

1. Redistributions of source code must retain the above copyright notice, this list of conditions and the following disclaimer.
2. Redistributions in binary form must reproduce the above copyright notice, this list of conditions and the following disclaimer in the documentation and/or other materials provided with the distribution.
3. Neither the name of the copyright holder nor the names of contributors may be used to endorse or promote products derived from this software without specific prior written permission.

THIS SOFTWARE IS PROVIDED BY THE AUTHOR AND CONTRIBUTOR(S) ``AS IS" AND ANY EXPRESS OR IMPLIED WARRANTIES, INCLUDING, BUT NOT LIMITED TO, THE IMPLIED WARRANTIES OF MERCHANTABILITY AND FITNESS FOR A PARTICULAR PURPOSE ARE DISCLAIMED. IN NO EVENT SHALL THE AUTHOR OR CONTRIBUTOR(S) BE LIABLE FOR ANY DIRECT, INDIRECT, INCIDENTAL, SPECIAL, EXEMPLARY, OR CONSEQUENTIAL DAMAGES (INCLUDING, BUT NOT LIMITED TO, PROCUREMENT OF SUBSTITUTE GOODS OR SERVICES; LOSS OF USE, DATA, OR PROFITS; OR BUSINESS INTERRUPTION) HOWEVER CAUSED AND ON ANY THEORY OF LIABILITY, WHETHER IN CONTRACT, STRICT LIABILITY, OR TORT (INCLUDING NEGLIGENCE OR OTHERWISE) ARISING IN ANY WAY OUT OF THE USE OF THIS SOFTWARE, EVEN IF ADVISED OF THE POSSIBILITY OF SUCH DAMAGE.

RSA Data Security License

Copyright (C) 1990, RSA Data Security, Inc. All rights reserved.

License to copy and use this software is granted provided that it is identified as the "RSA Data Security, Inc. MD5 Message-Digest Algorithm" in all material mentioning or referencing this software or this function.

License is also granted to make and use derivative works provided that such works are identified as "derived from the RSA Data Security, Inc. MD5 Message-Digest Algorithm" in all material mentioning or referencing the derived work.

RSA Data Security, Inc. makes no representations concerning either the merchantability of this software or the suitability of this software for any particular purpose. It is provided "as is" without express or implied warranty of any kind. These notices must be retained in any copies of any part of this documentation and/or software.

Copyright (c) Broadcom Corporation

Copyright (c) The Internet Society

expat 1.95.7

Copyright (c) 1998, 1999, 2000 Thai Open Source Software Center Ltd and Clark Cooper

Copyright (c) 2001, 2002 Expat maintainers.

Permission is hereby granted, free of charge, to any person obtaining a copy of this software and associated documentation files (the "Software"), to deal in the Software without restriction, including without limitation the rights to use, copy, modify, merge, publish, distribute, sublicense, and/or sell copies of the Software, and to permit persons to whom the Software is furnished to do so, subject to the following conditions:

The above copyright notice and this permission notice shall be included in all copies or substantial portions of the Software.

THE SOFTWARE IS PROVIDED "AS IS", WITHOUT WARRANTY OF ANY KIND, EXPRESS OR IMPLIED, INCLUDING BUT NOT LIMITED TO THE WARRANTIES OF MERCHANTABILITY, FITNESS FOR A PARTICULAR PURPOSE AND NONINFRINGEMENT. IN NO EVENT SHALL THE AUTHORS OR COPYRIGHT HOLDERS BE LIABLE FOR ANY CLAIM, DAMAGES OR OTHER LIABILITY, WHETHER IN AN ACTION OF CONTRACT, TORT OR OTHERWISE, ARISING FROM, OUT OF OR IN CONNECTION WITH THE SOFTWARE OR THE USE OR OTHER DEALINGS IN THE SOFTWARE.

GNU General Public License 2.0 (GPL)

This ARRIS Mobility product contains the following open source software packages licensed under the terms of the GPL 2.0 license:

- Linux 2.6.30
- Arptables 0.0.3-4 (also Copyright (c) Jay Fenlason)
- bridge-utils 1.2 (also Copyright (c) Stephen Hemminger, Copyright (c) Lenney Buytenhek)
- busybox 1.18.3 (also Copyright (C) 1999-2004 by Erik Andersen <andersen@codepoet.org>)
- conntrack 1.0.1
- dnsmasq 2.45 (also Copyright (c) Simon Kelley)
- ebtables 2.0.10-2 (also Copyright (c) Bart De Schuymer)
- ez-ipupdate 3.0.11b7 (also Copyright (c) Angus Mackay)
- haserl 0.9.26 (also Copyright (c) 2003-2007 Nathan Angelacos)
- inetd (also Copyright (c) Kenneth Albanowski Copyright (c) D. Jeff Dionne Copyright (c) Lineo, Inc.)
- iproute2 (also Copyright (c) Rusty Russell, Copyright (c) The Regents of the University of California, Copyright (c) USAGI WIDE Project, Copyright (c) Free Software Foundation, Copyright (c) Intel Corp. Copyright (c) Robert Olsson Uppsala University Sweden, Copyright (c) Harald Welte)
- iptables 1.4.0 (also Copyright (c) Netfilter Core Team)
- libnetfilter_conntrack (also (C) 2005-2011 Pablo Neira Ayuso)
- libnftnl (also "(c) 2001-2005 Netfilter Core Team, (c) 2008 by Pablo Neira Ayuso <pablo@netfilter.org>, (c) 2004 by Astaro AG, written by Harald Welte, (c) 2002-2006 by Harald Welte <laforge@gnumonks.org>")
- mtd-utils 1.4.9 (also Copyright Texas Instruments)
- ntpclient 2003_194 (also Copyright (c) Larry Doolittle)
- pppd 2.4.4 (also Copyright Fred N. van Kempen, <waltje@uWalt.NL.Mugnet.ORG>, Copyright Donald Becker, <becker@super.org>, Copyright Alan Cox, <alan@lxorguk.ukuu.org.uk>, Copyright Steve Whitehouse, <gw7rrm@eeshack3.swan.ac.uk>)
- rp-pppoe 3.10
- samba 3.0.25a (also Copyright (c) Ricky Poulton 1995-1998, Copyright (c) Richard Sharpe 1998)
- udev 136 (also Copyright (C) Kay Sievers)
- vconfig 1.6 (also Copyright (c) Ben Greear)
- wget 1.10.2 (also copyright (c) GNU Wget Authors)

GNU GENERAL PUBLIC LICENSE

Version 2, June 1991

Copyright (C) 1989, 1991 Free Software Foundation, Inc.,
51 Franklin Street, Fifth Floor, Boston, MA 02110-1301 USA

Everyone is permitted to copy and distribute verbatim copies of this license document, but changing it is not allowed.

Preamble

The licenses for most software are designed to take away your freedom to share and change it. By contrast, the GNU General Public License is intended to guarantee your freedom to share and change free software--to make sure the software is free for all its users. This General Public License applies to most of the Free Software Foundation's software and to any other program whose authors commit to using it. (Some other Free Software Foundation software is covered by the GNU Lesser General Public License instead.) You can apply it to your programs, too.

When we speak of free software, we are referring to freedom, not price. Our General Public Licenses are designed to make sure that you have the freedom to distribute copies of free software (and charge for this service if you wish), that you receive source code or can get it if you want it, that you can change the software or use pieces of it in new free programs; and that you know you can do these things.

To protect your rights, we need to make restrictions that forbid anyone to deny you these rights or to ask you to surrender the rights. These restrictions translate to certain responsibilities for you if you distribute copies of the software, or if you modify it.

For example, if you distribute copies of such a program, whether gratis or for a fee, you must give the recipients all the rights that you have. You must make sure that they, too, receive or can get the source code. And you must show them these terms so they know their rights.

We protect your rights with two steps: (1) copyright the software, and (2) offer you this license which gives you legal permission to copy, distribute and/or modify the software.

Also, for each author's protection and ours, we want to make certain that everyone understands that there is no warranty for this free software. If the software is modified by someone else and passed on, we want its recipients to know that what they have is not the original, so that any problems introduced by others will not reflect on the original authors' reputations.

Finally, any free program is threatened constantly by software patents. We wish to avoid the danger that redistributors of a free program will individually obtain patent licenses, in effect making the program proprietary. To prevent this, we have made it clear that any patent must be licensed for everyone's free use or not licensed at all.

The precise terms and conditions for copying, distribution and modification follow.

GNU GENERAL PUBLIC LICENSE TERMS AND CONDITIONS FOR COPYING, DISTRIBUTION AND MODIFICATION

0. This License applies to any program or other work which contains a notice placed by the copyright holder saying it may be distributed under the terms of this General Public License. The "Program", below, refers to any such program or work, and a "work based on the Program" means either the Program or any derivative work under copyright law: that is to say, a work containing the Program or a portion of it, either verbatim or with modifications and/or translated into another language. (Hereinafter, translation is included without limitation in the term "modification".) Each licensee is addressed as "you".

Activities other than copying, distribution and modification are not covered by this License; they are outside its scope. The act of running the Program is not restricted, and the output from the Program is covered only if its contents constitute a work based on the Program (independent of having been made by running the Program). Whether that is true depends on what the Program does.

1. You may copy and distribute verbatim copies of the Program's source code as you receive it, in any medium, provided that you conspicuously and appropriately publish on each copy an appropriate copyright notice and disclaimer of warranty; keep intact all the notices that refer to this License and to the absence of any warranty; and give any other recipients of the Program a copy of this License along with the Program.

You may charge a fee for the physical act of transferring a copy, and you may at your option offer warranty protection in exchange for a fee.

2. You may modify your copy or copies of the Program or any portion of it, thus forming a work based on the Program, and copy and distribute such modifications or work under the terms of Section 1 above, provided that you also meet all of these conditions:

a) You must cause the modified files to carry prominent notices stating that you changed the files and the date of any change.

b) You must cause any work that you distribute or publish, that in whole or in part contains or is derived from the Program or any part thereof, to be licensed as a whole at no charge to all third parties under the terms of this License.

c) If the modified program normally reads commands interactively when run, you must cause it, when started running for such interactive use in the most ordinary way, to print or display an announcement including an appropriate copyright notice and a notice that there is no warranty (or else, saying that you provide a warranty) and that users may redistribute the program under these conditions, and telling the user how to view a copy of this License. (Exception: if the Program itself is interactive but does not normally print such an announcement, your work based on the Program is not required to print an announcement.)

These requirements apply to the modified work as a whole. If identifiable sections of that work are not derived from the Program, and can be reasonably considered independent and separate works in themselves, then this License, and its terms, do not apply to those sections when you distribute them as separate works. But when you distribute the same sections as part of a whole which is a work based on the Program, the distribution of the whole must be on the terms of this License, whose permissions for other licensees extend to the entire whole, and thus to each and every part regardless of who wrote it.

Thus, it is not the intent of this section to claim rights or contest your rights to work written entirely by you; rather, the intent is to exercise the right to control the distribution of derivative or collective works based on the Program.

In addition, mere aggregation of another work not based on the Program with the Program (or with a work based on the Program) on a volume of a storage or distribution medium does not bring the other work under the scope of this License.

3. You may copy and distribute the Program (or a work based on it, under Section 2) in object code or executable form under the terms of Sections 1 and 2 above provided that you also do one of the following:

a) Accompany it with the complete corresponding machine-readable source code, which must be distributed under the terms of Sections 1 and 2 above on a medium customarily used for software interchange; or,

b) Accompany it with a written offer, valid for at least three years, to give any third party, for a charge no more than your cost of physically performing source distribution, a complete machine-readable copy of the corresponding source code, to be distributed under the terms of Sections 1 and 2 above on a medium customarily used for software interchange; or,

c) Accompany it with the information you received as to the offer to distribute corresponding source code. (This alternative is allowed only for noncommercial distribution and only if you received the program in object code or executable form with such an offer, in accord with Subsection b above.)

The source code for a work means the preferred form of the work for making modifications to it. For an executable work, complete source code means all the source code for all modules it contains, plus any associated interface definition files, plus the scripts used to control compilation and installation of the executable. However, as a special exception, the source code distributed need not include anything that is normally distributed (in either source or binary form) with the major components (compiler, kernel, and so on) of the operating system on which the executable runs, unless that component itself accompanies the executable.

If distribution of executable or object code is made by offering access to copy from a designated place, then offering equivalent access to copy the source code from the same place counts as distribution of the source code, even though third parties are not compelled to copy the source along with the object code.

4. You may not copy, modify, sublicense, or distribute the Program except as expressly provided under this License. Any attempt otherwise to copy, modify, sublicense or distribute the Program is void, and will automatically terminate your rights under this License. However, parties who have received copies, or rights, from you under this License will not have their licenses terminated so long as such parties remain in full compliance.

5. You are not required to accept this License, since you have not signed it. However, nothing else grants you permission to modify or distribute the Program or its derivative works. These actions are prohibited by law if you do not accept this License. Therefore, by modifying or distributing the Program (or any work based on the Program), you indicate your acceptance of this License to do so, and all its terms and conditions for copying, distributing or modifying the Program or works based on it.

6. Each time you redistribute the Program (or any work based on the Program), the recipient automatically receives a license from the original licensor to copy, distribute or modify the Program subject to these terms and conditions. You may not impose any further restrictions on the recipients' exercise of the rights granted herein. You are not responsible for enforcing compliance by third parties to this License.

7. If, as a consequence of a court judgment or allegation of patent infringement or for any other reason (not limited to patent issues), conditions are imposed on you (whether by court order, agreement or otherwise) that contradict the conditions of this License, they do not excuse you from the conditions of this License. If you cannot distribute so as to satisfy simultaneously your obligations under this License and any other pertinent obligations, then as a consequence you may not distribute the Program at all. For example, if a patent license would not permit royalty-free redistribution of the Program by all those who receive copies directly or indirectly through you, then the only way you could satisfy both it and this License would be to refrain entirely from distribution of the Program.

If any portion of this section is held invalid or unenforceable under any particular circumstance, the balance of the section is intended to apply and the section as a whole is intended to apply in other circumstances.

It is not the purpose of this section to induce you to infringe any patents or other property right claims or to contest validity of any such claims; this section has the sole purpose of protecting the integrity of the free software distribution system, which is implemented by public license practices. Many people have made generous contributions to the wide range of software distributed through that system in reliance on consistent application of that system; it is up to the author/donor to decide if he or she is willing to distribute software through any other system and a licensee cannot impose that choice.

This section is intended to make thoroughly clear what is believed to be a consequence of the rest of this License.

8. If the distribution and/or use of the Program is restricted in certain countries either by patents or by copyrighted interfaces, the original copyright holder who places the Program under this License may add an explicit geographical distribution limitation excluding those countries, so that distribution is permitted only in or among countries not thus excluded. In such case, this License incorporates the limitation as if written in the body of this License.

9. The Free Software Foundation may publish revised and/or new versions of the General Public License from time to time. Such new versions will be similar in spirit to the present version, but may differ in detail to address new problems or concerns.

Each version is given a distinguishing version number. If the Program specifies a version number of this License which applies to it and "any later version", you have the option of following the terms and conditions either of that version or of any later version published by the Free Software Foundation. If the Program does not specify a version number of this License, you may choose any version ever published by the Free Software Foundation.

10. If you wish to incorporate parts of the Program into other free programs whose distribution conditions are different, write to the author to ask for permission. For software which is copyrighted by the Free Software Foundation, write to the Free Software Foundation; we sometimes make exceptions for this. Our decision will be guided by the two goals of preserving the free status of all derivatives of our free software and of promoting the sharing and reuse of software generally.

NO WARRANTY

11. BECAUSE THE PROGRAM IS LICENSED FREE OF CHARGE, THERE IS NO WARRANTY FOR THE PROGRAM, TO THE EXTENT PERMITTED BY APPLICABLE LAW. EXCEPT WHEN OTHERWISE STATED IN WRITING THE COPYRIGHT HOLDERS AND/OR OTHER PARTIES PROVIDE THE PROGRAM "AS IS" WITHOUT WARRANTY OF ANY KIND, EITHER EXPRESSED OR IMPLIED, INCLUDING, BUT NOT LIMITED TO, THE IMPLIED WARRANTIES OF MERCHANTABILITY AND FITNESS FOR A PARTICULAR PURPOSE. THE ENTIRE RISK AS TO THE QUALITY AND PERFORMANCE OF THE PROGRAM IS WITH YOU. SHOULD THE PROGRAM PROVE DEFECTIVE, YOU ASSUME THE COST OF ALL NECESSARY SERVICING, REPAIR OR CORRECTION.

12. IN NO EVENT UNLESS REQUIRED BY APPLICABLE LAW OR AGREED TO IN WRITING WILL ANY COPYRIGHT HOLDER, OR ANY OTHER PARTY WHO MAY MODIFY AND/OR REDISTRIBUTE THE PROGRAM AS PERMITTED ABOVE, BE LIABLE TO YOU FOR DAMAGES, INCLUDING ANY GENERAL, SPECIAL, INCIDENTAL OR CONSEQUENTIAL DAMAGES ARISING OUT OF THE USE OR INABILITY TO USE THE PROGRAM (INCLUDING BUT NOT LIMITED TO LOSS OF DATA OR DATA BEING RENDERED INACCURATE OR LOSSES SUSTAINED BY YOU OR THIRD PARTIES OR A FAILURE OF THE PROGRAM TO OPERATE WITH ANY OTHER PROGRAMS), EVEN IF SUCH HOLDER OR OTHER PARTY HAS BEEN ADVISED OF THE POSSIBILITY OF SUCH DAMAGES.

GNU Lesser General Public License 2.1 (LGPL)

This ARRIS Mobility product contains the following open source software packages licensed under the terms of the LGPL 2.1 license:

- uClibc 0.9.27 (also Copyright (C) 2000-2006 Erik Andersen <andersen@uclibc.org>)

Version 2.1, February 1999

Copyright (C) 1991, 1999 Free Software Foundation, Inc.

51 Franklin Street, Fifth Floor, Boston, MA 02110-1301 USA

Everyone is permitted to copy and distribute verbatim copies of this license document, but changing it is not allowed.

[This is the first released version of the Lesser GPL. It also counts as the successor of the GNU Library Public License, version 2, hence the version number 2.1.]

Preamble

The licenses for most software are designed to take away your freedom to share and change it. By contrast, the GNU General Public Licenses are intended to guarantee your freedom to share and change free software--to make sure the software is free for all its users.

This license, the Lesser General Public License, applies to some specially designated software packages--typically libraries--of the Free Software Foundation and other authors who decide to use it. You can use it too, but we suggest you first think carefully about whether this license or the ordinary General Public License is the better strategy to use in any particular case, based on the explanations below.

When we speak of free software, we are referring to freedom of use, not price. Our General Public Licenses are designed to make sure that you have the freedom to distribute copies of free software (and charge for this service if you wish); that you receive source code or can get it if you want it; that you can change the software and use pieces of it in new free programs; and that you are informed that you can do these things.

To protect your rights, we need to make restrictions that forbid distributors to deny you these rights or to ask you to surrender these rights. These restrictions translate to certain responsibilities for you if you distribute copies of the library or if you modify it.

For example, if you distribute copies of the library, whether gratis or for a fee, you must give the recipients all the rights that we gave you. You must make sure that they, too, receive or can get the source code. If you link other code with the library, you must provide complete object files to the recipients, so that they can relink them with the library after making changes to the library and recompiling it. And you must show them these terms so they know their rights.

We protect your rights with a two-step method: (1) we copyright the library, and (2) we offer you this license, which gives you legal permission to copy, distribute and/or modify the library.

To protect each distributor, we want to make it very clear that there is no warranty for the free library. Also, if the library is modified by someone else and passed on, the recipients should know that what they have is not the original version, so that the original author's reputation will not be affected by problems that might be introduced by others.

Finally, software patents pose a constant threat to the existence of any free program. We wish to make sure that a company cannot effectively restrict the users of a free program by obtaining a restrictive license from a patent holder. Therefore, we insist that any patent license obtained for a version of the library must be consistent with the full freedom of use specified in this license.

Most GNU software, including some libraries, is covered by the ordinary GNU General Public License. This license, the GNU Lesser General Public License, applies to certain designated libraries, and is quite different from the ordinary General Public License. We use this license for certain libraries in order to permit linking those libraries into non-free programs.

When a program is linked with a library, whether statically or using a shared library, the combination of the two is legally speaking a combined work, a derivative of the original library. The ordinary General Public License therefore permits such linking only if the entire combination fits its criteria of freedom. The Lesser General Public License permits more lax criteria for linking other code with the library.

We call this license the "Lesser" General Public License because it does Less to protect the user's freedom than the ordinary General Public License. It also provides other free software developers Less of an advantage over competing non-free programs. These disadvantages are the reason we use the ordinary General Public License for many libraries. However, the Lesser license provides advantages in certain special circumstances.

For example, on rare occasions, there may be a special need to encourage the widest possible use of a certain library, so that it becomes a de-facto standard. To achieve this, non-free programs must be allowed to use the library. A more frequent case is that a free library does the same job as widely used non-free libraries. In this case, there is little to gain by limiting the free library to free software only, so we use the Lesser General Public License.

In other cases, permission to use a particular library in non-free programs enables a greater number of people to use a large body of free software. For example, permission to use the GNU C Library in non-free programs enables many more people to use the whole GNU operating system, as well as its variant, the GNU/Linux operating system.

Although the Lesser General Public License is less protective of the users' freedom, it does ensure that the user of a program that is linked with the Library has the freedom and the wherewithal to run that program using a modified version of the Library.

The precise terms and conditions for copying, distribution and modification follow. Pay close attention to the difference between a "work based on the library" and a "work that uses the library". The former contains code derived from the library, whereas the latter must be combined with the library in order to run.

TERMS AND CONDITIONS FOR COPYING, DISTRIBUTION AND MODIFICATION

0. This License Agreement applies to any software library or other program which contains a notice placed by the copyright holder or other authorized party saying it may be distributed under the terms of this Lesser General Public License (also called "this License"). Each licensee is addressed as "you".

A "library" means a collection of software functions and/or data prepared so as to be conveniently linked with application programs (which use some of those functions and data) to form executables.

The "Library", below, refers to any such software library or work which has been distributed under these terms. A "work based on the Library" means either the Library or any derivative work under copyright law: that is to say, a work containing the Library or a portion of it, either verbatim or with modifications and/or translated straightforwardly into another language. (Hereinafter, translation is included without limitation in the term "modification".)

"Source code" for a work means the preferred form of the work for making modifications to it. For a library, complete source code means all the source code for all modules it contains, plus any associated interface definition files, plus the scripts used to control compilation and installation of the library.

Activities other than copying, distribution and modification are not covered by this License; they are outside its scope. The act of running a program using the Library is not restricted, and output from such a program is covered only if its contents constitute a work based on the Library (independent of the use of the Library in a tool for writing it). Whether that is true depends on what the Library does and what the program that uses the Library does.

1. You may copy and distribute verbatim copies of the Library's complete source code as you receive it, in any medium, provided that you conspicuously and appropriately publish on each copy an appropriate copyright notice and disclaimer of warranty; keep intact all the notices that refer to this License and to the absence of any warranty; and distribute a copy of this License along with the Library.

You may charge a fee for the physical act of transferring a copy, and you may at your option offer warranty protection in exchange for a fee.

2. You may modify your copy or copies of the Library or any portion of it, thus forming a work based on the Library, and copy and distribute such modifications or work under the terms of Section 1 above, provided that you also meet all of these conditions:

* a) The modified work must itself be a software library.

* b) You must cause the files modified to carry prominent notices stating that you changed the files and the date of any change.

* c) You must cause the whole of the work to be licensed at no charge to all third parties under the terms of this License.

* d) If a facility in the modified Library refers to a function or a table of data to be supplied by an application program that uses the facility, other than as an argument passed when the facility is invoked, then you must make a good faith effort to ensure that, in the event an application does not supply such function or table, the facility still operates, and performs whatever part of its purpose remains meaningful.

(For example, a function in a library to compute square roots has a purpose that is entirely well-defined independent of the application. Therefore, Subsection 2d requires that any application-supplied function or table used by this function must be optional: if the application does not supply it, the square root function must still compute square roots.)

These requirements apply to the modified work as a whole. If identifiable sections of that work are not derived from the Library, and can be reasonably considered independent and separate works in themselves, then this License, and its terms, do not apply to those sections when you distribute them as separate works. But when you distribute the same sections as part of a whole which is a work based on the Library, the distribution of the whole must be on the terms of this License, whose permissions for other licensees extend to the entire whole, and thus to each and every part regardless of who wrote it.

Thus, it is not the intent of this section to claim rights or contest your rights to work written entirely by you; rather, the intent is to exercise the right to control the distribution of derivative or collective works based on the Library.

In addition, mere aggregation of another work not based on the Library with the Library (or with a work based on the Library) on a volume of a storage or distribution medium does not bring the other work under the scope of this License.

3. You may opt to apply the terms of the ordinary GNU General Public License instead of this License to a given copy of the Library. To do this, you must alter all the notices that refer to this License, so that they refer to the ordinary GNU General Public License, version 2, instead of to this License. (If a newer version than version 2 of the ordinary GNU General Public License has appeared, then you can specify that version instead if you wish.) Do not make any other change in these notices.

Once this change is made in a given copy, it is irreversible for that copy, so the ordinary GNU General Public License applies to all subsequent copies and derivative works made from that copy.

This option is useful when you wish to copy part of the code of the Library into a program that is not a library.

4. You may modify and distribute the Library (or a portion or derivative of it, under Section 2) in object code or executable form under the terms of Sections 1 and 2 above provided that you accompany it with the complete corresponding machine-readable source code, which must be distributed under the terms of Sections 1 and 2 above on a medium customarily used for software interchange.

If distribution of object code is made by offering access to copy from a designated place, then offering equivalent access to copy the source code from the same place satisfies the requirement to distribute the source code, even though third parties are not compelled to copy the source along with the object code.

5. A program that contains no derivative of any portion of the Library, but is designed to work with the Library by being compiled or linked with it, is called a "work that uses the Library". Such a work, in isolation, is not a derivative work of the Library, and therefore falls outside the scope of this License.

However, linking a "work that uses the Library" with the Library creates an executable that is a derivative of the Library (because it contains portions of the Library), rather than a "work that uses the library". The executable is therefore covered by this License. Section 6 states terms for distribution of such executables.

When a "work that uses the Library" uses material from a header file that is part of the Library, the object code for the work may be a derivative work of the Library even though the source code is not. Whether this is true is especially significant if the work can be linked without the Library, or if the work is itself a library. The threshold for this to be true is not precisely defined by law.

If such an object file uses only numerical parameters, data structure layouts and accessors, and small macros and small inline functions (ten lines or less in length), then the use of the object file is unrestricted, regardless of whether it is legally a derivative work. (Executables containing this object code plus portions of the Library will still fall under Section 6.)

Otherwise, if the work is a derivative of the Library, you may distribute the object code for the work under the terms of Section 6. Any executables containing that work also fall under Section 6, whether or not they are linked directly with the Library itself.

6. As an exception to the Sections above, you may also combine or link a "work that uses the Library" with the Library to produce a work containing portions of the Library, and distribute that work under terms of your choice, provided that the terms permit modification of the work for the customer's own use and reverse engineering for debugging such modifications.

You must give prominent notice with each copy of the work that the Library is used in it and that the Library and its use are covered by this License. You must supply a copy of this License. If the work during execution displays copyright notices, you must include the copyright notice for the Library among them, as well as a reference directing the user to the copy of this License. Also, you must do one of these things:

* a) Accompany the work with the complete corresponding machine-readable source code for the Library including whatever changes were used in the work (which must be distributed under Sections 1 and 2 above); and, if the work is an executable linked with the Library, with the complete machine-readable "work that uses the Library", as object code and/or source code, so that the user can modify the Library and then relink to produce a modified executable containing the modified Library. (It is understood that the user who changes the contents of definitions files in the Library will not necessarily be able to recompile the application to use the modified definitions.)

* b) Use a suitable shared library mechanism for linking with the Library. A suitable mechanism is one that (1) uses at run time a copy of the library already present on the user's computer system, rather than copying library functions into the executable, and (2) will operate properly with a modified version of the library, if the user installs one, as long as the modified version is interface-compatible with the version that the work was made with.

* c) Accompany the work with a written offer, valid for at least three years, to give the same user the materials specified in Subsection 6a, above, for a charge no more than the cost of performing this distribution.

* d) If distribution of the work is made by offering access to copy from a designated place, offer equivalent access to copy the above specified materials from the same place.

* e) Verify that the user has already received a copy of these materials or that you have already sent this user a copy.

For an executable, the required form of the "work that uses the Library" must include any data and utility programs needed for reproducing the executable from it. However, as a special exception, the materials to be distributed need not include anything that is normally distributed (in either source or binary form) with the major components (compiler, kernel, and so on) of the operating system on which the executable runs, unless that component itself accompanies the executable.

It may happen that this requirement contradicts the license restrictions of other proprietary libraries that do not normally accompany the operating system. Such a contradiction means you cannot use both them and the Library together in an executable that you distribute.

7. You may place library facilities that are a work based on the Library side-by-side in a single library together with other library facilities not covered by this License, and distribute such a combined library, provided that the separate distribution of the work based on the Library and of the other library facilities is otherwise permitted, and provided that you do these two things:

* a) Accompany the combined library with a copy of the same work based on the Library, uncombined with any other library facilities. This must be distributed under the terms of the Sections above.

* b) Give prominent notice with the combined library of the fact that part of it is a work based on the Library, and explaining where to find the accompanying uncombined form of the same work.

8. You may not copy, modify, sublicense, link with, or distribute the Library except as expressly provided under this License. Any attempt otherwise to copy, modify, sublicense, link with, or distribute the Library is void, and will automatically terminate your rights under this License. However, parties who have received copies, or rights, from you under this License will not have their licenses terminated so long as such parties remain in full compliance.

9. You are not required to accept this License, since you have not signed it. However, nothing else grants you permission to modify or distribute the Library or its derivative works. These actions are prohibited by law if you do not accept this License. Therefore, by modifying or distributing the Library (or any work based on the Library), you indicate your acceptance of this License to do so, and all its terms and conditions for copying, distributing or modifying the Library or works based on it.

10. Each time you redistribute the Library (or any work based on the Library), the recipient automatically receives a license from the original licensor to copy, distribute, link with or modify the Library subject to these terms and conditions. You may not impose any further restrictions on the recipients' exercise of the rights granted herein. You are not responsible for enforcing compliance by third parties with this License.

11. If, as a consequence of a court judgment or allegation of patent infringement or for any other reason (not limited to patent issues), conditions are imposed on you (whether by court order, agreement or otherwise) that contradict the conditions of this License, they do not excuse you from the conditions of this License. If you cannot distribute so as to satisfy simultaneously your obligations under this License and any other pertinent obligations, then as a consequence you may not distribute the Library at all. For example, if a patent license would not permit royalty-free redistribution of the Library by all those who receive copies directly or indirectly through you, then the only way you could satisfy both it and this License would be to refrain entirely from distribution of the Library.

If any portion of this section is held invalid or unenforceable under any particular circumstance, the balance of the section is intended to apply, and the section as a whole is intended to apply in other circumstances.

It is not the purpose of this section to induce you to infringe any patents or other property right claims or to contest validity of any such claims; this section has the sole purpose of protecting the integrity of the free software distribution system which is implemented by public license practices. Many people have made generous contributions to the wide range of software distributed through that system in reliance on consistent application of that system; it is up to the author/donor to decide if he or she is willing to distribute software through any other system and a licensee cannot impose that choice. This section is intended to make thoroughly clear what is believed to be a consequence of the rest of this License.

12. If the distribution and/or use of the Library is restricted in certain countries either by patents or by copyrighted interfaces, the original copyright holder who places the Library under this License may add an explicit geographical distribution limitation excluding those countries, so that distribution is permitted only in or among countries not thus excluded. In such case, this License incorporates the limitation as if written in the body of this License.

13. The Free Software Foundation may publish revised and/or new versions of the Lesser General Public License from time to time. Such new versions will be similar in spirit to the present version, but may differ in detail to address new problems or concerns.

Each version is given a distinguishing version number. If the Library specifies a version number of this License which applies to it and "any later version", you have the option of following the terms and conditions either of that version or of any later version published by the Free Software Foundation. If the Library does not specify a license version number, you may choose any version ever published by the Free Software Foundation.

14. If you wish to incorporate parts of the Library into other free programs whose distribution conditions are incompatible with these, write to the author to ask for permission. For software which is copyrighted by the Free Software Foundation, write to the Free Software Foundation; we sometimes make exceptions for this. Our decision will be guided by the two goals of preserving the free status of all derivatives of our free software and of promoting the sharing and reuse of software generally.

NO WARRANTY

15. BECAUSE THE LIBRARY IS LICENSED FREE OF CHARGE, THERE IS NO WARRANTY FOR THE LIBRARY, TO THE EXTENT PERMITTED BY APPLICABLE LAW. EXCEPT WHEN OTHERWISE STATED IN WRITING THE COPYRIGHT HOLDERS AND/OR OTHER PARTIES PROVIDE THE LIBRARY "AS IS" WITHOUT WARRANTY OF ANY KIND, EITHER EXPRESSED OR IMPLIED, INCLUDING, BUT NOT LIMITED TO, THE IMPLIED WARRANTIES OF MERCHANTABILITY AND FITNESS FOR A PARTICULAR PURPOSE. THE ENTIRE RISK AS TO THE QUALITY AND PERFORMANCE OF THE LIBRARY IS WITH YOU. SHOULD THE LIBRARY PROVE DEFECTIVE, YOU ASSUME THE COST OF ALL NECESSARY SERVICING, REPAIR OR CORRECTION.

16. IN NO EVENT UNLESS REQUIRED BY APPLICABLE LAW OR AGREED TO IN WRITING WILL ANY COPYRIGHT HOLDER, OR ANY OTHER PARTY WHO MAY MODIFY AND/OR REDISTRIBUTE THE LIBRARY AS PERMITTED ABOVE, BE LIABLE TO YOU FOR DAMAGES, INCLUDING ANY GENERAL, SPECIAL, INCIDENTAL OR CONSEQUENTIAL DAMAGES ARISING OUT OF THE USE OR INABILITY TO USE THE LIBRARY (INCLUDING BUT NOT LIMITED TO LOSS OF DATA OR DATA BEING RENDERED INACCURATE OR LOSSES SUSTAINED BY YOU OR THIRD PARTIES OR A FAILURE OF THE LIBRARY TO OPERATE WITH ANY OTHER SOFTWARE), EVEN IF SUCH HOLDER OR OTHER PARTY HAS BEEN ADVISED OF THE POSSIBILITY OF SUCH DAMAGES.

END OF TERMS AND CONDITIONS

libtecla 1.6.1

Martin C. Shepherd License

Copyright (c) 2000, 2001, 2002, 2003, 2004 by Martin C. Shepherd.

All rights reserved.

Permission is hereby granted, free of charge, to any person obtaining a copy of this software and associated documentation files (the "Software"), to deal in the Software without restriction, including without limitation the rights to use, copy, modify, merge, publish, distribute, and/or sell copies of the Software, and to permit persons to whom the Software is furnished to do so, provided that the above copyright notice(s) and this permission notice appear in all copies of the Software and that both the above copyright notice(s) and this permission notice appear in supporting documentation. THE SOFTWARE IS PROVIDED "AS IS", WITHOUT WARRANTY OF ANY KIND, EXPRESS OR IMPLIED, INCLUDING BUT NOT LIMITED TO THE WARRANTIES OF MERCHANTABILITY, FITNESS FOR A PARTICULAR PURPOSE AND NONINFRINGEMENT OF THIRD PARTY RIGHTS. IN NO EVENT SHALL THE COPYRIGHT HOLDER OR HOLDERS INCLUDED IN THIS NOTICE BE LIABLE FOR ANY CLAIM, OR ANY SPECIAL INDIRECT OR CONSEQUENTIAL DAMAGES, OR ANY DAMAGES WHATSOEVER RESULTING FROM LOSS OF USE, DATA OR PROFITS, WHETHER IN AN ACTION OF CONTRACT, NEGLIGENCE OR OTHER TORTIOUS ACTION, ARISING OUT OF OR IN CONNECTION WITH THE USE OR PERFORMANCE OF THIS SOFTWARE. Except as contained in this notice, the name of a copyright holder shall not be used in advertising or otherwise to promote the sale, use or other dealings in this Software without prior written authorization of the copyright holder.

lua 5.1

Lua is licensed under the terms of the MIT license reproduced below. This means that Lua is free software and can be used for both academic and commercial purposes at absolutely no cost.

For details and rationale, see <http://www.lua.org/license.html>.

Copyright (C) 1994-2012 Lua.org, PUC-Rio.

Permission is hereby granted, free of charge, to any person obtaining a copy of this software and associated documentation files (the "Software"), to deal in the Software without restriction, including without limitation the rights to use, copy, modify, merge, publish, distribute, sublicense, and/or sell copies of the Software, and to permit persons to whom the Software is furnished to do so, subject to the following conditions:

The above copyright notice and this permission notice shall be included in all copies or substantial portions of the Software.

THE SOFTWARE IS PROVIDED "AS IS", WITHOUT WARRANTY OF ANY KIND, EXPRESS OR IMPLIED, INCLUDING BUT NOT LIMITED TO THE WARRANTIES OF MERCHANTABILITY, FITNESS FOR A PARTICULAR PURPOSE AND NONINFRINGEMENT. IN NO EVENT SHALL THE AUTHORS OR COPYRIGHT HOLDERS BE LIABLE FOR ANY CLAIM, DAMAGES OR OTHER LIABILITY, WHETHER IN AN ACTION OF CONTRACT, TORT OR OTHERWISE, ARISING FROM, OUT OF OR IN CONNECTION WITH THE SOFTWARE OR THE USE OR OTHER DEALINGS IN THE SOFTWARE.

miniupnp 20070228

Thomas BERNARD License

Copyright (c) 2006-2007, Thomas BERNARD

All rights reserved.

Redistribution and use in source and binary forms, with or without modification, are permitted provided that the following conditions are met:

- * Redistributions of source code must retain the above copyright notice, this list of conditions and the following disclaimer.

- * Redistributions in binary form must reproduce the above copyright notice, this list of conditions and the following disclaimer in the documentation and/or other materials provided with the distribution.

- * The name of the author may not be used to endorse or promote products derived from this software without specific prior written permission.

THIS SOFTWARE IS PROVIDED BY THE COPYRIGHT HOLDERS AND CONTRIBUTORS "AS IS" AND ANY EXPRESS OR IMPLIED WARRANTIES, INCLUDING, BUT NOT LIMITED TO, THE IMPLIED WARRANTIES OF MERCHANTABILITY AND FITNESS FOR A PARTICULAR PURPOSE ARE DISCLAIMED. IN NO EVENT SHALL THE COPYRIGHT OWNER OR CONTRIBUTORS BE LIABLE FOR ANY DIRECT, INDIRECT, INCIDENTAL, SPECIAL, EXEMPLARY, OR CONSEQUENTIAL DAMAGES (INCLUDING, BUT NOT LIMITED TO, PROCUREMENT OF SUBSTITUTE GOODS OR SERVICES; LOSS OF USE, DATA, OR PROFITS; OR BUSINESS INTERRUPTION) HOWEVER CAUSED AND ON ANY THEORY OF LIABILITY, WHETHER IN CONTRACT, STRICT LIABILITY, OR TORT (INCLUDING NEGLIGENCE OR OTHERWISE) ARISING IN ANY WAY OUT OF THE USE OF THIS SOFTWARE, EVEN IF ADVISED OF THE POSSIBILITY OF SUCH DAMAGE.

muhttp 1.1.3

Copyright (c) 2005 Robbert Haarman

Permission is hereby granted, free of charge, to any person obtaining a copy of this software and associated documentation files (the "Software"), to deal in the Software without restriction, including without limitation the rights to use, copy, modify, merge, publish, distribute, sublicense, and/or sell copies of the Software, and to permit persons to whom the Software is furnished to do so, subject to the following conditions:

The above copyright notice and this permission notice shall be included in all copies or substantial portions of the Software.

THE SOFTWARE IS PROVIDED "AS IS", WITHOUT WARRANTY OF ANY KIND, EXPRESS OR IMPLIED, INCLUDING BUT NOT LIMITED TO THE WARRANTIES OF MERCHANTABILITY, FITNESS FOR A PARTICULAR PURPOSE AND NONINFRINGEMENT. IN NO EVENT SHALL THE AUTHORS OR COPYRIGHT HOLDERS BE LIABLE FOR ANY CLAIM, DAMAGES OR OTHER LIABILITY, WHETHER IN AN ACTION OF CONTRACT, TORT OR OTHERWISE, ARISING FROM, OUT OF OR IN CONNECTION WITH THE SOFTWARE OR THE USE OR OTHER DEALINGS IN THE SOFTWARE.

OpenSSL 0.9.8k

OpenSSL SSLeay License

LICENSE ISSUES

The OpenSSL toolkit stays under a dual license, i.e. both the conditions of the OpenSSL License and the original SSLeay license apply to the toolkit. See below for the actual license texts. Actually both licenses are BSD-style Open Source licenses. In case of any license issues related to OpenSSL please contact openssl-core@openssl.org.

OpenSSL License

Copyright (c) 1998-2008 The OpenSSL Project. All rights reserved.

Redistribution and use in source and binary forms, with or without modification, are permitted provided that the following conditions are met:

1. Redistributions of source code must retain the above copyright notice, this list of conditions and the following disclaimer.
2. Redistributions in binary form must reproduce the above copyright notice, this list of conditions and the following disclaimer in the documentation and/or other materials provided with the distribution.
3. All advertising materials mentioning features or use of this software must display the following acknowledgment:
"This product includes software developed by the OpenSSL Project for use in the OpenSSL Toolkit. (<http://www.openssl.org/>)"
4. The names "OpenSSL Toolkit" and "OpenSSL Project" must not be used to endorse or promote products derived from this software without prior written permission. For written permission, please contact openssl-core@openssl.org.
5. Products derived from this software may not be called "OpenSSL" nor may "OpenSSL" appear in their names without prior written permission of the OpenSSL Project.
6. Redistributions of any form whatsoever must retain the following acknowledgment:

"This product includes software developed by the OpenSSL Project for use in the OpenSSL Toolkit (<http://www.openssl.org/>)"

THIS SOFTWARE IS PROVIDED BY THE OpenSSL PROJECT "AS IS" AND ANY EXPRESSED OR IMPLIED WARRANTIES, INCLUDING, BUT NOT LIMITED TO, THE IMPLIED WARRANTIES OF MERCHANTABILITY AND FITNESS FOR A PARTICULAR PURPOSE ARE DISCLAIMED. IN NO EVENT SHALL THE OpenSSL PROJECT OR ITS CONTRIBUTORS BE LIABLE FOR ANY DIRECT, INDIRECT, INCIDENTAL, SPECIAL, EXEMPLARY, OR CONSEQUENTIAL DAMAGES (INCLUDING, BUT NOT LIMITED TO, PROCUREMENT OF SUBSTITUTE GOODS OR SERVICES; LOSS OF USE, DATA, OR PROFITS; OR BUSINESS INTERRUPTION) HOWEVER CAUSED AND ON ANY THEORY OF LIABILITY, WHETHER IN CONTRACT, STRICT LIABILITY, OR TORT (INCLUDING NEGLIGENCE OR OTHERWISE) ARISING IN ANY WAY OUT OF THE USE OF THIS SOFTWARE, EVEN IF ADVISED OF THE POSSIBILITY OF SUCH DAMAGE.

This product includes cryptographic software written by Eric Young (eay@cryptsoft.com). This product includes software written by Tim Hudson (tjh@cryptsoft.com).

Original SSLeay License

Copyright (C) 1995-1998 Eric Young (eay@cryptsoft.com)

All rights reserved.

This package is an SSL implementation written by Eric Young (eay@cryptsoft.com).

The implementation was written so as to conform with Netscapes SSL.

This library is free for commercial and non-commercial use as long as the following conditions are adhered to. The following conditions apply to all code found in this distribution, be it the RC4, RSA, lhash, DES, etc., code; not just the SSL code. The SSL documentation included with this distribution is covered by the same copyright terms except that the holder is Tim Hudson (tjh@cryptsoft.com).

Copyright remains Eric Young's, and as such any Copyright notices in the code are not to be removed. If this package is used in a product, Eric Young should be given attribution as the author of the parts of the library used. This can be in the form of a textual message at program startup or in documentation (online or textual) provided with the package. Redistribution and use in source and binary forms, with or without modification, are permitted provided that the following conditions are met:

1. Redistributions of source code must retain the copyright notice, this list of conditions and the following disclaimer.
2. Redistributions in binary form must reproduce the above copyright notice, this list of conditions and the following disclaimer in the documentation and/or other materials provided with the distribution.
3. All advertising materials mentioning features or use of this software must display the following acknowledgement:
"This product includes cryptographic software written by Eric Young (eay@cryptsoft.com)"
The word 'cryptographic' can be left out if the routines from the library being used are not cryptographic related :-).
4. If you include any Windows specific code (or a derivative thereof) from the apps directory (application code) you must include an acknowledgement:
"This product includes software written by Tim Hudson (tjh@cryptsoft.com)"

HIS SOFTWARE IS PROVIDED BY ERIC YOUNG ``AS IS'' AND ANY EXPRESS OR IMPLIED WARRANTIES, INCLUDING, BUT NOT LIMITED TO, THE IMPLIED WARRANTIES OF MERCHANTABILITY AND FITNESS FOR A PARTICULAR PURPOSE ARE DISCLAIMED. IN NO EVENT SHALL THE AUTHOR OR CONTRIBUTORS BE LIABLE FOR ANY DIRECT, INDIRECT, INCIDENTAL, SPECIAL, EXEMPLARY, OR CONSEQUENTIAL DAMAGES (INCLUDING, BUT NOT LIMITED TO, PROCUREMENT OF SUBSTITUTE GOODS OR SERVICES; LOSS OF USE, DATA, OR PROFITS; OR BUSINESS INTERRUPTION) HOWEVER CAUSED AND ON ANY THEORY OF LIABILITY, WHETHER IN CONTRACT, STRICT LIABILITY, OR TORT (INCLUDING NEGLIGENCE OR OTHERWISE) ARISING IN ANY WAY OUT OF THE USE OF THIS SOFTWARE, EVEN IF ADVISED OF THE POSSIBILITY OF SUCH DAMAGE. The licence and distribution terms for any publically available version or derivative of this code cannot be changed. i.e. this code cannot simply be copied and put under another distribution licence [including the GNU Public Licence.]

pcrc 5.0

PCRE is a library of functions to support regular expressions whose syntax and semantics are as close as possible to those of the Perl 5 language. Release 5 of PCRE is distributed under the terms of the "BSD" licence, as specified below. The documentation for PCRE, supplied in the "doc" directory, is distributed under the same terms as the software itself.

Written by: Philip Hazel <ph10@cam.ac.uk>
University of Cambridge Computing Service,
Cambridge, England. Phone: +44 1223 334714.
Copyright (c) 1997-2004 University of Cambridge
All rights reserved.

Redistribution and use in source and binary forms, with or without modification, are permitted provided that the following conditions are met:

- * Redistributions of source code must retain the above copyright notice, this list of conditions and the following disclaimer.
- * Redistributions in binary form must reproduce the above copyright notice, this list of conditions and the following disclaimer in the documentation and/or other materials provided with the distribution.
- * Neither the name of the University of Cambridge nor the names of its contributors may be used to endorse or promote products derived from this software without specific prior written permission.

THIS SOFTWARE IS PROVIDED BY THE COPYRIGHT HOLDERS AND CONTRIBUTORS "AS IS" AND ANY EXPRESS OR IMPLIED WARRANTIES, INCLUDING, BUT NOT LIMITED TO, THE IMPLIED WARRANTIES OF MERCHANTABILITY AND FITNESS FOR A PARTICULAR PURPOSE ARE DISCLAIMED. IN NO EVENT SHALL THE COPYRIGHT OWNER OR CONTRIBUTORS BE LIABLE FOR ANY DIRECT, INDIRECT, INCIDENTAL, SPECIAL, EXEMPLARY, OR CONSEQUENTIAL DAMAGES (INCLUDING, BUT NOT LIMITED TO, PROCUREMENT OF SUBSTITUTE GOODS OR SERVICES; LOSS OF USE, DATA, OR PROFITS; OR BUSINESS INTERRUPTION) HOWEVER CAUSED AND ON ANY THEORY OF LIABILITY, WHETHER IN CONTRACT, STRICT LIABILITY, OR TORT (INCLUDING NEGLIGENCE OR OTHERWISE) ARISING IN ANY WAY OUT OF THE USE OF THIS SOFTWARE, EVEN IF ADVISED OF THE POSSIBILITY OF SUCH DAMAGE.

PPPD Composite Licenses

Copyright (c) 1984-2000 Carnegie Mellon University. All rights reserved.

Redistribution and use in source and binary forms, with or without modification, are permitted provided that the following conditions are met:

1. Redistributions of source code must retain the above copyright notice, this list of conditions and the following disclaimer.
2. Redistributions in binary form must reproduce the above copyright notice, this list of conditions and the following disclaimer in the documentation and/or other materials provided with the distribution.
3. The name "Carnegie Mellon University" must not be used to endorse or promote products derived from this software without prior written permission. For permission or any legal details, please contact

Office of Technology Transfer
Carnegie Mellon University
5000 Forbes Avenue
Pittsburgh, PA 15213-3890
(412) 268-4387, fax: (412) 268-7395
tech-transfer@andrew.cmu.edu

4. Redistributions of any form whatsoever must retain the following acknowledgment:

"This product includes software developed by Computing Services at Carnegie Mellon University (<http://www.cmu.edu/computing/>)."

CARNEGIE MELLON UNIVERSITY DISCLAIMS ALL WARRANTIES WITH REGARD TO THIS SOFTWARE, INCLUDING ALL IMPLIED WARRANTIES OF MERCHANTABILITY AND FITNESS, IN NO EVENT SHALL CARNEGIE MELLON UNIVERSITY BE LIABLE FOR ANY SPECIAL, INDIRECT OR CONSEQUENTIAL DAMAGES OR ANY DAMAGES WHATSOEVER RESULTING FROM LOSS OF USE, DATA OR PROFITS, WHETHER IN AN ACTION OF CONTRACT, NEGLIGENCE OR OTHER TORTIOUS ACTION, ARISING OUT OF OR IN CONNECTION WITH THE USE OR PERFORMANCE OF THIS SOFTWARE.

Copyright (c) 1999-2004 Paul Mackerras. All rights reserved.

Redistribution and use in source and binary forms, with or without modification, are permitted provided that the following conditions are met:

1. Redistributions of source code must retain the above copyright notice, this list of conditions and the following disclaimer.
2. The name(s) of the authors of this software must not be used to endorse or promote products derived from this software without prior written permission.
3. Redistributions of any form whatsoever must retain the following acknowledgment:

"This product includes software developed by Paul Mackerras
<paulus@samba.org>".

THE AUTHORS OF THIS SOFTWARE DISCLAIM ALL WARRANTIES WITH REGARD TO THIS SOFTWARE, INCLUDING ALL IMPLIED WARRANTIES OF MERCHANTABILITY AND FITNESS, IN NO EVENT SHALL THE AUTHORS BE LIABLE FOR ANY SPECIAL, INDIRECT OR CONSEQUENTIAL DAMAGES OR ANY DAMAGES WHATSOEVER RESULTING FROM LOSS OF USE, DATA OR PROFITS, WHETHER IN AN ACTION OF CONTRACT, NEGLIGENCE OR OTHER TORTIOUS ACTION, ARISING OUT OF OR IN CONNECTION WITH THE USE OR PERFORMANCE OF THIS SOFTWARE.

Author: Arvin Schnell <arvin@suse.de> . (No copyright, but listed the author for attribution.)

Copyright (C) 2002 Roaring Penguin Software Inc.

This plugin may be distributed according to the terms of the GNU General Public License, version 2 or (at your option) any later version.

Copyright (C) 2002 Roaring Penguin Software Inc.

Copyright (C) 1996, Matjaz Godec <gody@elgo.si>
Copyright (C) 1996, Lars Fenneberg <in5y050@public.uni-hamburg.de>
Copyright (C) 1997, Miguel A.L. Paraz <map@iphil.net>

Copyright (C) 1995,1996,1997,1998 Lars Fenneberg <lf@elemental.net>
Copyright (C) 2002 Roaring Penguin Software Inc.

MPPE support is by Ralf Hofmann, <ralf.hofmann@elvido.net>, with modification from Frank Cusack, <frank@google.com>.

This plugin may be distributed according to the terms of the GNU General Public License, version 2 or (at your option) any later version.

Author: Ben McKeegan ben@netservers.co.uk

Copyright (C) 2002 Netservers

This plugin may be distributed according to the terms of the GNU General Public License, version 2 or (at your option) any later version. See the respective source files to find out which copyrights apply.

Copyright (C) 2002 Roaring Penguin Software Inc.

Permission to use, copy, modify, and distribute this software for any purpose and without fee is hereby granted, provided that this copyright and permission notice appear on all copies and supporting documentation, the name of Roaring Penguin Software Inc. not be used in advertising or publicity pertaining to distribution of the program without specific prior permission, and notice be given in supporting documentation that copying and distribution is by permission of Roaring Penguin Software Inc.. Roaring Penguin Software Inc. makes no representations about the suitability of this software for any purpose. It is provided "as is" without express or implied warranty.

Copyright (C) 1995,1996,1997,1998 Lars Fenneberg <lf@elemental.net>

Permission to use, copy, modify, and distribute this software for any purpose and without fee is hereby granted, provided that this copyright and permission notice appear on all copies and supporting documentation, the name of Lars Fenneberg not be used in advertising or publicity pertaining to distribution of the program without specific prior permission, and notice be given in supporting documentation that copying and distribution is by permission of Lars Fenneberg. Lars Fenneberg makes no representations about the suitability of this software for any purpose. It is provided "as is" without express or implied warranty.

Copyright 1992 Livingston Enterprises, Inc.

Livingston Enterprises, Inc. 6920 Koll Center Parkway Pleasanton, CA 94566

Permission to use, copy, modify, and distribute this software for any purpose and without fee is hereby granted, provided that this copyright and permission notice appear on all copies and supporting documentation, the name of Livingston Enterprises, Inc. not be used in advertising or publicity pertaining to distribution of the program without specific prior permission, and notice be given in supporting documentation that copying and distribution is by permission of Livingston Enterprises, Inc. Livingston Enterprises, Inc. makes no representations about the suitability of this software for any purpose. It is provided "as is" without express or implied warranty.

[C] The Regents of the University of Michigan and Merit Network, Inc. 1992, 1993, 1994, 1995 All Rights Reserved

Permission to use, copy, modify, and distribute this software and its documentation for any purpose and without fee is hereby granted, provided that the above copyright notice and this permission notice appear in all copies of the software and derivative works or modified versions thereof, and that both the copyright notice and this permission and disclaimer notice appear in supporting documentation. THIS SOFTWARE IS PROVIDED "AS IS" WITHOUT WARRANTY OF ANY KIND, EITHER EXPRESS OR IMPLIED, INCLUDING WITHOUT LIMITATION WARRANTIES OF MERCHANTABILITY AND FITNESS FOR A PARTICULAR PURPOSE. THE REGENTS OF THE UNIVERSITY OF MICHIGAN AND MERIT NETWORK, INC. DO NOT WARRANT THAT THE FUNCTIONS CONTAINED IN THE SOFTWARE WILL MEET LICENSEE'S REQUIREMENTS OR THAT OPERATION WILL BE UNINTERRUPTED OR ERROR FREE. The Regents of the University of Michigan and Merit Network, Inc. shall not be liable for any special, indirect, incidental or consequential damages with respect to any claim by Licensee or any third party arising from use of the software.

Copyright (C) 1990, 1991-2, RSA Data Security, Inc. Created 1991.
All rights reserved.

License to copy and use this software is granted provided that it is identified as the "RSA Data Security, Inc. MD5 Message-Digest Algorithm" in all material mentioning or referencing this software or this function.

License is also granted to make and use derivative works provided that such works are identified as "derived from the RSA Data Security, Inc. MD5 Message-Digest Algorithm" in all material mentioning or referencing the derived work. RSA Data Security, Inc. makes no representations concerning either the merchantability of this software or the suitability of this software for any particular purpose. It is provided "as is" without express or implied warranty of any kind.

These notices must be retained in any copies of any part of this documentation and/or software.

Copyright (c) 2000 by Sun Microsystems, Inc.
All rights reserved.

Permission to use, copy, modify, and distribute this software and its documentation is hereby granted, provided that the above copyright notice appears in all copies.

SUN MAKES NO REPRESENTATION OR WARRANTIES ABOUT THE SUITABILITY OF THE SOFTWARE, EITHER EXPRESS OR IMPLIED, INCLUDING BUT NOT LIMITED TO THE IMPLIED WARRANTIES OF MERCHANTABILITY, FITNESS FOR A PARTICULAR PURPOSE, OR NON-INFRINGEMENT. SUN SHALL NOT BE LIABLE FOR ANY DAMAGES SUFFERED BY LICENSEE AS A RESULT OF USING, MODIFYING OR DISTRIBUTING THIS SOFTWARE OR ITS DERIVATIVES

Copyright (c) 1985, 1986 The Regents of the University of California.
All rights reserved.

This code is derived from software contributed to Berkeley by James A. Woods, derived from original work by Spencer Thomas and Joseph Orost.

Redistribution and use in source and binary forms, with or without modification, are permitted provided that the following conditions are met:

1. Redistributions of source code must retain the above copyright notice, this list of conditions and the following disclaimer.
2. Redistributions in binary form must reproduce the above copyright notice, this list of conditions and the following disclaimer in the documentation and/or other materials provided with the distribution.
3. All advertising materials mentioning features or use of this software must display the following acknowledgement: This product includes software developed by the University of California, Berkeley and its contributors.
4. Neither the name of the University nor the names of its contributors may be used to endorse or promote products derived from this software without specific prior written permission.

THIS SOFTWARE IS PROVIDED BY THE REGENTS AND CONTRIBUTORS ``AS IS'' AND ANY EXPRESS OR IMPLIED WARRANTIES, INCLUDING, BUT NOT LIMITED TO, THE IMPLIED WARRANTIES OF MERCHANTABILITY AND FITNESS FOR A PARTICULAR PURPOSE ARE DISCLAIMED. IN NO EVENT SHALL THE REGENTS OR CONTRIBUTORS BE LIABLE FOR ANY DIRECT, INDIRECT, INCIDENTAL, SPECIAL, EXEMPLARY, OR CONSEQUENTIAL DAMAGES (INCLUDING, BUT NOT LIMITED TO, PROCUREMENT OF SUBSTITUTE GOODS OR SERVICES; LOSS OF USE, DATA, OR PROFITS; OR BUSINESS INTERRUPTION) HOWEVER CAUSED AND ON ANY THEORY OF LIABILITY, WHETHER IN CONTRACT, STRICT LIABILITY, OR TORT (INCLUDING NEGLIGENCE OR OTHERWISE) ARISING IN ANY WAY OUT OF THE USE OF THIS SOFTWARE, EVEN IF ADVISED OF THE POSSIBILITY OF SUCH DAMAGE.

Copyright (c) 1989 Regents of the University of California.
All rights reserved.

Redistribution and use in source and binary forms are permitted provided that the above copyright notice and this paragraph are duplicated in all such forms and that any documentation, advertising materials, and other materials related to such distribution and use acknowledge that the software was developed by the University of California, Berkeley. The name of the University may not be used to endorse or promote products derived from this software without specific prior written permission. THIS SOFTWARE IS PROVIDED ``AS IS'' AND WITHOUT ANY EXPRESS OR IMPLIED WARRANTIES, INCLUDING, WITHOUT LIMITATION, THE IMPLIED WARRANTIES OF MERCHANTABILITY AND FITNESS FOR A PARTICULAR PURPOSE.

Van Jacobson (van@helios.ee.lbl.gov), Dec 31, 1989:
- Initial distribution.

Modified June 1993 by Paul Mackerras, paulus@cs.anu.edu.au, so that the entire packet being decompressed doesn't have to be in contiguous memory (just the compressed header).

Copyright 1995-2000 EPFL-LRC/ICA, and are licensed under the GNU Lesser General Public License.
Written 1995-2000 by Werner Almesberger, EPFL-LRC/ICA */

Copyright 2000 Mitchell Blank Jr.
Based in part on work from Jens Axboe and Paul Mackerras.
Updated to ppp-2.4.1 by Bernhard Kaindl

Updated to ppp-2.4.2 by David Woodhouse 2004.
- disconnect method added
- remove_options() abuse removed.

This program is free software; you can redistribute it and/or modify it under the terms of the GNU General Public License as published by the Free Software Foundation; either version 2 of the License, or (at your option) any later version.

Copyright (C) 1995 Jean-loup Gailly and Mark Adler

This software is provided 'as-is', without any express or implied warranty. In no event will the authors be held liable for any damages arising from the use of this software. Permission is granted to anyone to use this software for any purpose, including commercial applications, and to alter it and redistribute it freely, subject to the following restrictions: 1. The origin of this software must not be misrepresented; you must not claim that you wrote the original software. If you use this software in a product, an acknowledgment in the product documentation would be appreciated but is not required. 2. Altered source versions must be plainly marked as such, and must not be misrepresented as being the original software. 3. This notice may not be removed or altered from any source distribution.

Jean-loup Gailly Mark Adler
gzip@prep.ai.mit.edu madler@alumni.caltech.edu

Copyright (C) 2003 Andrew Bartlet <abartlet@samba.org>

Copyright 1999 Paul Mackerras, Alan Curry.
Copyright (C) 2002 Roaring Penguin Software Inc.
Copyright (C) 1996, Matjaz Godec <gody@elgo.si>
Copyright (C) 1996, Lars Fenneberg <in5y050@public.uni-hamburg.de>
Copyright (C) 1997, Miguel A.L. Paraz <map@iphil.net>
Copyright (C) 1995,1996,1997,1998 Lars Fenneberg <lf@elemental.net>
Copyright (C) 2002 Roaring Penguin Software Inc.
Copyright (C) 2003, Sean E. Millichamp <sean at bruenor dot org>

This plugin may be distributed according to the terms of the GNU General Public License, version 2 or (at your option) any later version.

Copyright (C) 2000 by Roaring Penguin Software Inc.

This program may be distributed according to the terms of the GNU General Public License, version 2 or (at your option) any later version.

Copyright (C) 2000-2001 by Roaring Penguin Software Inc.
Copyright (C) 2004 Marco d'Itri <md@linux.it>

This program may be distributed according to the terms of the GNU General Public License, version 2 or (at your option) any later version.

Copyright (c) 2001 by Sun Microsystems, Inc.
All rights reserved.

Non-exclusive rights to redistribute, modify, translate, and use this software in source and binary forms, in whole or in part, is hereby granted, provided that the above copyright notice is duplicated in any source form, and that neither the name of the copyright holder nor the author is used to endorse or promote products derived from this software.

THIS SOFTWARE IS PROVIDED ``AS IS" AND WITHOUT ANY EXPRESS OR IMPLIED WARRANTIES, INCLUDING, WITHOUT LIMITATION, THE IMPLIED WARRANTIES OF MERCHANTABILITY AND FITNESS FOR A PARTICULAR PURPOSE.

Original version by James Carlson

Copyright (c) 2002 Google, Inc.
All rights reserved.

Redistribution and use in source and binary forms, with or without modification, are permitted provided that the following conditions are met:

1. Redistributions of source code must retain the above copyright notice, this list of conditions and the following disclaimer.
2. Redistributions in binary form must reproduce the above copyright notice, this list of conditions and the following disclaimer in the documentation and/or other materials provided with the distribution.
3. The name(s) of the authors of this software must not be used to endorse or promote products derived from this software without prior written permission.

THE AUTHORS OF THIS SOFTWARE DISCLAIM ALL WARRANTIES WITH REGARD TO THIS SOFTWARE, INCLUDING ALL IMPLIED WARRANTIES OF MERCHANTABILITY AND FITNESS, IN NO EVENT SHALL THE AUTHORS BE LIABLE FOR ANY SPECIAL, INDIRECT OR CONSEQUENTIAL DAMAGES OR ANY DAMAGES WHATSOEVER RESULTING FROM LOSS OF USE, DATA OR PROFITS, WHETHER IN AN ACTION OF CONTRACT, NEGLIGENCE OR OTHER TORTIOUS ACTION, ARISING OUT OF OR IN CONNECTION WITH THE USE OR PERFORMANCE OF THIS SOFTWARE.

Copyright (c) 1999 Tommi Komulainen. All rights reserved.

Redistribution and use in source and binary forms, with or without modification, are permitted provided that the following conditions are met:

1. Redistributions of source code must retain the above copyright notice, this list of conditions and the following disclaimer.
2. Redistributions in binary form must reproduce the above copyright notice, this list of conditions and the following disclaimer in the documentation and/or other materials provided with the distribution.
3. The name(s) of the authors of this software must not be used to endorse or promote products derived from this software without prior written permission.
4. Redistributions of any form whatsoever must retain the following acknowledgment:

"This product includes software developed by Tommi Komulainen
<Tommi.Komulainen@iki.fi>".

THE AUTHORS OF THIS SOFTWARE DISCLAIM ALL WARRANTIES WITH REGARD TO THIS SOFTWARE, INCLUDING ALL IMPLIED WARRANTIES OF MERCHANTABILITY AND FITNESS, IN NO EVENT SHALL THE AUTHORS BE LIABLE FOR ANY SPECIAL, INDIRECT OR CONSEQUENTIAL DAMAGES OR ANY DAMAGES WHATSOEVER RESULTING FROM LOSS OF USE, DATA OR PROFITS, WHETHER IN AN ACTION OF CONTRACT, NEGLIGENCE OR OTHER TORTIOUS ACTION, ARISING OUT OF OR IN CONNECTION WITH THE USE OR PERFORMANCE OF THIS SOFTWARE.

Original version, based on RFC2023 :

Copyright (c) 1995, 1996, 1997 Francis.Dupont@inria.fr, INRIA Rocquencourt,
Alain.Durand@imag.fr, IMAG,
Jean-Luc.Richier@imag.fr, IMAG-LSR.

Copyright (c) 1998, 1999 Francis.Dupont@inria.fr, GIE DYADE,
Alain.Durand@imag.fr, IMAG,
Jean-Luc.Richier@imag.fr, IMAG-LSR.

Ce travail a été fait au sein du GIE DYADE (Groupement d'Intérêt Économique ayant pour membres BULL S.A. et l'INRIA). Ce logiciel informatique est disponible aux conditions usuelles dans la recherche, c'est-à-dire qu'il peut être utilisé, copié, modifié, distribué à l'unique condition que ce texte soit conservé afin que l'origine de ce logiciel soit reconnue. Le nom de l'Institut National de Recherche en Informatique et en Automatique (INRIA), de l'IMAG, ou d'une personne morale ou physique ayant participé à l'élaboration de ce logiciel ne peut être utilisé sans son accord préalable explicite. Ce logiciel est fourni tel quel sans aucune garantie, support ou responsabilité d'aucune sorte. Ce logiciel est dérivé de sources d'origine "University of California at Berkeley" et "Digital Equipment Corporation" couvertes par des copyrights. L'Institut d'Informatique et de Mathématiques Appliquées de Grenoble (IMAG) est une fédération d'unités mixtes de recherche du CNRS, de l'Institut National Polytechnique de Grenoble et de l'Université Joseph Fourier regroupant sept laboratoires dont le laboratoire Logiciels, Systèmes, Réseaux (LSR).

This work has been done in the context of GIE DYADE (joint R & D venture between BULL S.A. and INRIA). This software is available with usual "research" terms with the aim of retain credits of the software. Permission to use, copy, modify and distribute this software for any purpose and without fee is hereby granted, provided that the above copyright notice and this permission notice appear in all copies, and the name of INRIA, IMAG, or any contributor not be used in advertising or publicity pertaining to this material without the prior explicit permission. The software is provided "as is" without any warranties, support or liabilities of any kind. This software is derived from source code from "University of California at Berkeley" and "Digital Equipment Corporation" protected by copyrights. Grenoble's Institute of Computer Science and Applied Mathematics (IMAG) is a federation of seven research units funded by the CNRS, National Polytechnic Institute of Grenoble and University Joseph Fourier. The research unit in Software, Systems, Networks (LSR) is member of IMAG.

Copyright (c) 1995 Eric Rosenquist. All rights reserved.

Redistribution and use in source and binary forms, with or without modification, are permitted provided that the following conditions are met:

1. Redistributions of source code must retain the above copyright notice, this list of conditions and the following disclaimer.
2. Redistributions in binary form must reproduce the above copyright notice, this list of conditions and the following disclaimer in the documentation and/or other materials provided with the distribution.
3. The name(s) of the authors of this software must not be used to endorse or promote products derived from this software without prior written permission.

THE AUTHORS OF THIS SOFTWARE DISCLAIM ALL WARRANTIES WITH REGARD TO THIS SOFTWARE, INCLUDING ALL IMPLIED WARRANTIES OF MERCHANTABILITY AND FITNESS, IN NO EVENT SHALL THE AUTHORS BE LIABLE FOR ANY SPECIAL, INDIRECT OR CONSEQUENTIAL DAMAGES OR ANY DAMAGES WHATSOEVER RESULTING FROM LOSS OF USE, DATA OR PROFITS, WHETHER IN AN ACTION OF CONTRACT, NEGLIGENCE OR OTHER TORTIOUS ACTION, ARISING OUT OF OR IN CONNECTION WITH THE USE OR PERFORMANCE OF THIS SOFTWARE.

Copyright (C) Andrew Tridgell 1999-2004

Copyright (C) Anton Blanchard 2001

Copyright (C) Paul 'Rusty' Russell 2000

Copyright (C) Jeremy Allison 2000-2003

** NOTE! The following LGPL license applies to the tdb library. This does NOT imply that all of Samba is released under the LGPL

This library is free software; you can redistribute it and/or modify it under the terms of the GNU Lesser General Public License as published by the Free Software Foundation; either version 2 of the License, or (at your option) any later version. This library is distributed in the hope that it will be useful, but WITHOUT ANY WARRANTY; without even the implied warranty of MERCHANTABILITY or FITNESS FOR A PARTICULAR PURPOSE. See the GNU Lesser General Public License for more details.

You should have received a copy of the GNU Lesser General Public License along with this library; if not, write to the Free Software Foundation, Inc., 59 Temple Place, Suite 330, Boston, MA 02111-1307 USA

radvd 1.8.3

radvd license

The author(s) grant permission for redistribution and use in source and binary forms, with or without modification, of the software and documentation provided that the following conditions are met:

0. If you receive a version of the software that is specifically labelled as not being for redistribution (check the version message and/or README), you are not permitted to redistribute that version of the software in any way or form.
1. All terms of all other applicable copyrights and licenses must be followed.
2. Redistributions of source code must retain the authors' copyright notice(s), this list of conditions, and the following disclaimer.
3. Redistributions in binary form must reproduce the authors' copyright notice(s), this list of conditions, and the following disclaimer in the documentation and/or other materials provided with the distribution.
4. All advertising materials mentioning features or use of this software must display the following acknowledgement with the name(s) of the authors as specified in the copyright notice(s) substituted where indicated: This product includes software developed by the authors which are mentioned at the start of the source files and other contributors.
5. Neither the name(s) of the author(s) nor the names of its contributors may be used to endorse or promote products derived from this software without specific prior written permission.

THIS SOFTWARE IS PROVIDED BY ITS AUTHORS AND CONTRIBUTORS ``AS IS'' AND ANY EXPRESS OR IMPLIED WARRANTIES, INCLUDING, BUT NOT LIMITED TO, THE IMPLIED WARRANTIES OF MERCHANTABILITY AND FITNESS FOR A PARTICULAR PURPOSE ARE DISCLAIMED. IN NO EVENT SHALL THE AUTHORS OR CONTRIBUTORS BE LIABLE FOR ANY DIRECT, INDIRECT, INCIDENTAL, SPECIAL, EXEMPLARY, OR CONSEQUENTIAL DAMAGES (INCLUDING, BUT NOT LIMITED TO, PROCUREMENT OF SUBSTITUTE GOODS OR SERVICES; LOSS OF USE, DATA, OR PROFITS; OR BUSINESS INTERRUPTION) HOWEVER CAUSED AND ON ANY THEORY OF LIABILITY, WHETHER IN CONTRACT, STRICT LIABILITY, OR TORT (INCLUDING NEGLIGENCE OR OTHERWISE) ARISING IN ANY WAY OUT OF THE USE OF THIS SOFTWARE, EVEN IF ADVISED OF THE POSSIBILITY OF SUCH DAMAGE.

SimCList Component

Copyright (c) 2007,2008 Mij

Dropbear - a SSH2 server 0.52

Copyright (c) 2002-2008 Matt Johnston
Portions copyright (c) 2004 Mihnea Stoenescu
All rights reserved.

Permission is hereby granted, free of charge, to any person obtaining a copy of this software and associated documentation files (the "Software"), to deal in the Software without restriction, including without limitation the rights to use, copy, modify, merge, publish, distribute, sublicense, and/or sell copies of the Software, and to permit persons to whom the Software is furnished to do so, subject to the following conditions: The above copyright notice and this permission notice shall be included in all copies or substantial portions of the Software.

THE SOFTWARE IS PROVIDED "AS IS", WITHOUT WARRANTY OF ANY KIND, EXPRESS OR IMPLIED, INCLUDING BUT NOT LIMITED TO THE WARRANTIES OF MERCHANTABILITY, FITNESS FOR A PARTICULAR PURPOSE AND NONINFRINGEMENT. IN NO EVENT SHALL THE AUTHORS OR COPYRIGHT HOLDERS BE LIABLE FOR ANY CLAIM, DAMAGES OR OTHER LIABILITY, WHETHER IN AN ACTION OF CONTRACT, TORT OR OTHERWISE, ARISING FROM, OUT OF OR IN CONNECTION WITH THE SOFTWARE OR THE USE OR OTHER DEALINGS IN THE SOFTWARE.

=====

LibTomCrypt and LibTomMath are written by Tom St Denis, and are Public Domain.

=====

sshpty.c is taken from OpenSSH 3.5p1,

Copyright (c) 1995 Tatu Ylonen <ylo@cs.hut.fi>, Timo Rinne <tri@iki.fi>, Espoo, Finland
All rights reserved

"As far as I am concerned, the code I have written for this software can be used freely for any purpose. Any derived versions of this software must be clearly marked as such, and if the derived work is incompatible with the protocol description in the RFC file, it must be called by a name other than "ssh" or "Secure Shell". "

=====

loginrec.c is written primarily by Andre Lucas, Jason Downs, Theo de Raadt:

Copyright (c) 2000 Andre Lucas.
Portions copyright (c) 1998 Todd C. Miller
Portions copyright (c) 1996 Jason Downs
Portions Copyright (c) 1996 Theo de Raadt.

loginrec.h is written by Andre Lucas:

Copyright (c) 2000 Andre Lucas.

atomicio.h,atomicio.c written by Theo de Raadt (1995-1999)

Copyright (c) 1995,1999 Theo de Raadt.
And are licensed under the following terms:
Copyright (c) <YEAR>, <OWNER>
All rights reserved.

Redistribution and use in source and binary forms, with or without modification, are permitted provided that the following conditions are met: Redistributions of source code must retain the above copyright notice, this list of conditions and the following disclaimer.

Redistributions in binary form must reproduce the above copyright notice, this list of conditions and the following disclaimer in the documentation and/or other materials provided with the distribution.

THIS SOFTWARE IS PROVIDED BY THE COPYRIGHT HOLDERS AND CONTRIBUTORS "AS IS" AND ANY EXPRESS OR IMPLIED WARRANTIES, INCLUDING, BUT NOT LIMITED TO, THE IMPLIED WARRANTIES OF MERCHANTABILITY AND FITNESS FOR A PARTICULAR PURPOSE ARE DISCLAIMED. IN NO EVENT SHALL THE COPYRIGHT HOLDER OR CONTRIBUTORS BE LIABLE FOR ANY DIRECT, INDIRECT, INCIDENTAL, SPECIAL, EXEMPLARY, OR CONSEQUENTIAL DAMAGES (INCLUDING, BUT NOT LIMITED TO, PROCUREMENT OF SUBSTITUTE GOODS OR SERVICES; LOSS OF USE, DATA, OR PROFITS; OR BUSINESS INTERRUPTION) HOWEVER CAUSED AND ON ANY THEORY OF LIABILITY, WHETHER IN CONTRACT, STRICT LIABILITY, OR TORT (INCLUDING NEGLIGENCE OR OTHERWISE) ARISING IN ANY WAY OUT OF THE USE OF THIS SOFTWARE, EVEN IF ADVISED OF THE POSSIBILITY OF SUCH DAMAGE.

=====

strcat() is (c) Todd C. Miller (included in util.c --) are from OpenSSH 3.6.1p2, and are licensed under the BSD-Modified license:

Copyright (c) 1998 Todd C. Miller , < OWNER > All rights reserved.

Redistribution and use in source and binary forms, with or without modification, are permitted provided that the following conditions are met: Redistributions of source code must retain the above copyright notice, this list of conditions and the following disclaimer. Redistributions in binary form must reproduce the above copyright notice, this list of conditions and the following disclaimer in the documentation and/or other materials provided with the distribution. Neither the name of the < ORGANIZATION > nor the names of its contributors may be used to endorse or promote products derived from this software without specific prior written permission. THIS SOFTWARE IS PROVIDED BY THE COPYRIGHT HOLDERS AND CONTRIBUTORS "AS IS" AND ANY EXPRESS OR IMPLIED WARRANTIES, INCLUDING, BUT NOT LIMITED TO, THE IMPLIED WARRANTIES OF MERCHANTABILITY AND FITNESS FOR A PARTICULAR PURPOSE ARE DISCLAIMED. IN NO EVENT SHALL THE COPYRIGHT OWNER OR CONTRIBUTORS BE LIABLE FOR ANY DIRECT, INDIRECT, INCIDENTAL, SPECIAL, EXEMPLARY, OR CONSEQUENTIAL DAMAGES (INCLUDING, BUT NOT LIMITED TO, PROCUREMENT OF SUBSTITUTE GOODS OR SERVICES; LOSS OF USE, DATA, OR PROFITS; OR BUSINESS INTERRUPTION) HOWEVER CAUSED AND ON ANY THEORY OF LIABILITY, WHETHER IN CONTRACT, STRICT LIABILITY, OR TORT (INCLUDING NEGLIGENCE OR OTHERWISE) ARISING IN ANY WAY OUT OF THE USE OF THIS SOFTWARE, EVEN IF ADVISED OF THE POSSIBILITY OF SUCH DAMAGE.

=====

Import code in keyimport.c is modified from PuTTY's import.c, licensed as follows:

PuTTY is copyright 1997-2003 Simon Tatham.

Portions copyright Robert de Bath, Joris van Rantwijk, Delian Delchev, Andreas Schultz, Jeroen Massar, Wez Furlong, Nicolas Barry, Justin Bradford, and CORE SDI S.A.

Permission is hereby granted, free of charge, to any person obtaining a copy of this software and associated documentation files (the "Software"), to deal in the Software without restriction, including without limitation the rights to use, copy, modify, merge, publish, distribute, sublicense, and/or sell copies of the Software, and to permit persons to whom the Software is furnished to do so, subject to the following conditions: The above copyright notice and this permission notice shall be included in all copies or substantial portions of the Software.

THE SOFTWARE IS PROVIDED "AS IS", WITHOUT WARRANTY OF ANY KIND, EXPRESS OR IMPLIED, INCLUDING BUT NOT LIMITED TO THE WARRANTIES OF MERCHANTABILITY, FITNESS FOR A PARTICULAR PURPOSE AND NONINFRINGEMENT. IN NO EVENT SHALL THE COPYRIGHT HOLDERS BE LIABLE FOR ANY CLAIM, DAMAGES OR OTHER LIABILITY, WHETHER IN AN ACTION OF CONTRACT, TORT OR OTHERWISE, ARISING FROM, OUT OF OR IN CONNECTION WITH THE SOFTWARE OR THE USE OR OTHER DEALINGS IN THE SOFTWARE.

WIDE-DHCPv6

Copyright (C) 2002 WIDE Project.

All rights reserved.

Redistribution and use in source and binary forms, with or without modification, are permitted provided that the following conditions are met:

1. Redistributions of source code must retain the above copyright notice, this list of conditions and the following disclaimer.
2. Redistributions in binary form must reproduce the above copyright notice, this list of conditions and the following disclaimer in the documentation and/or other materials provided with the distribution.
3. Neither the name of the project nor the names of its contributors may be used to endorse or promote products derived from this software without specific prior written permission.

THIS SOFTWARE IS PROVIDED BY THE PROJECT AND CONTRIBUTORS ``AS IS'' AND ANY EXPRESS OR IMPLIED WARRANTIES, INCLUDING, BUT NOT LIMITED TO, THE IMPLIED WARRANTIES OF MERCHANTABILITY AND FITNESS FOR A PARTICULAR PURPOSE ARE DISCLAIMED. IN NO EVENT SHALL THE PROJECT OR CONTRIBUTORS BE LIABLE FOR ANY DIRECT, INDIRECT, INCIDENTAL, SPECIAL, EXEMPLARY, OR CONSEQUENTIAL DAMAGES (INCLUDING, BUT NOT LIMITED TO, PROCUREMENT OF SUBSTITUTE GOODS OR SERVICES; LOSS OF USE, DATA, OR PROFITS; OR BUSINESS INTERRUPTION) HOWEVER CAUSED AND ON ANY THEORY OF LIABILITY, WHETHER IN CONTRACT, STRICT LIABILITY, OR TORT (INCLUDING NEGLIGENCE OR OTHERWISE) ARISING IN ANY WAY OUT OF THE USE OF THIS SOFTWARE, EVEN IF ADVISED OF THE POSSIBILITY OF SUCH DAMAGE.

Copyright (C)2000 YOSHIFUJI Hideaki

Copyright (c) 1995, 1999 Berkeley Software Design, Inc.

zlib 1.2.3

Copyright (C) 1995-2005 Jean-loup Gailly and Mark Adler

This software is provided 'as-is', without any express or implied warranty. In no event will the authors be held liable for any damages arising from the use of this software. Permission is granted to anyone to use this software for any purpose, including commercial applications, and to alter it and redistribute it freely, subject to the following restrictions:

1. The origin of this software must not be misrepresented; you must not claim that you wrote the original software. If you use this software in a product, an acknowledgment in the product documentation would be appreciated but is not required.
2. Altered source versions must be plainly marked as such, and must not be misrepresented as being the original software.
3. This notice may not be removed or altered from any source distribution.

Copyright (c) Mark Adler

Portions Copyright ARRIS Mobility, LLC. 2009-2012

Portions Copyright Broadcom Corporation

Portions Copyright AltoCom, Inc.

Appendix A ARRIS[®] Gateway Captive Portal Implementation

This section contains information about the ARRIS Gateway Captive Portal Support.

Overview

ARRIS follows the 2Wire RPC specification for implementation of Captive Portal.

The Captive Portal feature redirects all TCP traffic destined to port 80 and redirects it to a Captive Portal URL. A White-IP address list can be configured to avoid the captive portal redirect. All HTTP traffic destined to the IP addresses within this white IP address list will not be redirected to the Captive Portal. Any Changes to the Captive Portal parameters will take place immediately and do not require a reboot.

- ◆ PortalURL can be a maximum of 512 characters long.
- ◆ A maximum of 500 White IP Addresses are supported WhiteIPAddresses list takes a comma-separated string, which can be Individual IP addresses or a range of IP addresses. For a range of IP Addresses, subnet mask is required.
- ◆ The following formats of IP address are accepted:
 - Individual IP address - 144.130.120.62 or 144.130.120.62/32
 - Range of 64 IP addresses - 144.130.120.64/26
- ◆ White IP Address list gets rewritten on any changes.
- ◆ Clearing the Captive Portal URL disables Captive Portal. Turning OFF the enable parameter can also disable captive Portal functionality.
- ◆ Captive Portal is **disabled by default and enabled via TR-069**
- ◆ White List can be a combination of FQDN (Fully Qualified Domain Names) and white IP Address/cidr.
- ◆ FQDNs will be resolved to IP addresses on BOOT and whenever a new list is pushed.
- ◆ For NVG595, Captive Portal implementation only redirects port 80 traffic.Traffic to port 443 is allowed.
- ◆ DNS Traffic will not be blocked

Captive Portal RPC

RPC supported per 2Wire requirements that will set Captive Portal Parameters.

```
<xs:schema xmlns:xs="http://www.w3.org/2001/XMLSchema"
  xmlns:soapenv="http://schemas.xmlsoap.org/soap/envelope/"
  xmlns:soapenc="http://schemas.xmlsoap.org/soap/encoding/"
  xmlns:tns="urn:dslforum-org:cwmp-1-0"
  targetNamespace="urn:dslforum-org:cwmp-1-0"
  elementFormDefault="unqualified"
  attributeFormDefault="unqualified">
  <xs:import namespace="http://schemas.xmlsoap.org/soap/envelope/"
    schemaLocation="soapenv.xsd" />
  <xs:import namespace="http://schemas.xmlsoap.org/soap/encoding/"
    schemaLocation="soapenc.xsd" />

  <xs:complexType name="CaptivePortalParamStruct">
    <xs:sequence>
      <xs:element name="Enable" type="soapenc:boolean">
        <xs:annotation>
          <xs:documentation>If true, the Captive Portal is enabled.<
xs:documentation>
          <xs:documentation>If false, the Captive Portal is
disabled.</xs:documentation>
        </xs:annotation>
      </xs:element>
      <xs:element name="RedirectURL">
        <xs:annotation>
          <xs:documentation>the URL to be redirected to.<
xs:documentation>
        </xs:annotation>
        <xs:simpleType>
          <xs:restriction base="xs:string">
            <xs:maxLength value="512"/>
          </xs:restriction>
        </xs:simpleType>
      </xs:element>
      <xs:element name="WhiteList" type="tns:WhiteList">
        <xs:annotation>
          <xs:documentation>a list of sites and IP address to be
escaped by the Captive Portal.</xs:documentation>
        </xs:annotation>
      </xs:element>
    </xs:sequence>
  </xs:complexType>
```

X_00D09E_GetCaptivePortalParams RPC:

```
<!-- X_00D09E_GetCaptivePortalParams -->
  <xs:element name="X_00D09E_GetCaptivePortalParams">
    <xs:annotation>
      <xs:documentation>X_00D09E_GetCaptivePortalParams message is
to get the Captive Portal parameters on a CPE.</xs:documentation>
    </xs:annotation>
    <xs:complexType/>
  </xs:element>
```

```
<!-- X_00D09E_GetCaptivePortalParamsResponse -->
  <xs:element name="X_00D09E_GetCaptivePortalParamsResponse">
    <xs:annotation>
      <xs:documentation>X_00D09E_GetCaptivePortalParamsResponse
response message for X_00D09E_GetCaptivePortalParams request.<
xs:documentation>
    </xs:annotation>
    <xs:complexType>
      <xs:sequence>
        <xs:element name="CaptivePortalParamStruct"
type="tns:CaptivePortalParamStruct"/>
      </xs:sequence>
    </xs:complexType>
  </xs:element>
```

X_00D09E_SetCaptivePortalParams RPC:

```
<!-- X_00D09E_SetCaptivePortalParams -->
  <xs:element name="X_00D09E_SetCaptivePortalParams">
    <xs:annotation>
      <xs:documentation>X_00D09E_SetCaptivePortalParams message to
set the Captive Portal parameters on a CPE.</xs:documentation>
    </xs:annotation>
    <xs:complexType>
      <xs:sequence>
        <xs:element name="CaptivePortalParamStruct"
type="tns:CaptivePortalParamStruct"/>
      </xs:sequence>
    </xs:complexType>
  </xs:element>

<!-- X_00D09E_SetCaptivePortalParamsResponse -->
  <xs:element name="X_00D09E_SetCaptivePortalParamsResponse">
    <xs:annotation>
      <xs:documentation>X_00D09E_SetCaptivePortalParamsResponse
response message is a response for X_00D09E_SetCaptivePortalParams
request.</xs:documentation>
    </xs:annotation>
    <xs:complexType/>
  </xs:element>
```

Appendix B Quality of Service (QoS) Examples

This section contains information about the ARRIS Gateway QoS implementation.

Overview

When packets arrive on a high speed interface and are forwarded to a low speed interface, there is contention for bandwidth. This is the use case for QoS: to make effective use of bandwidth.

The basic steps for Quality of Service are to match and identify packets as belonging to a class of traffic, and to give each class of traffic a certain behavior such as priority queuing or bandwidth shaping across critical networking bottlenecks.

Packets forwarded through the system are classified using sets of filter rules to match various criteria, for example p-bit, DSCP, IP address, port, etc. The matching rule can set the classification, which is the name of the queue that is to be used.

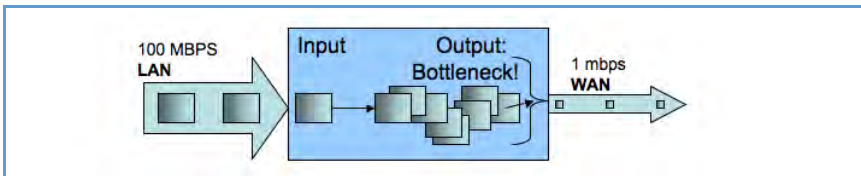

Figure 1. Illustration of upstream congestion, all traffic is consistently delayed.

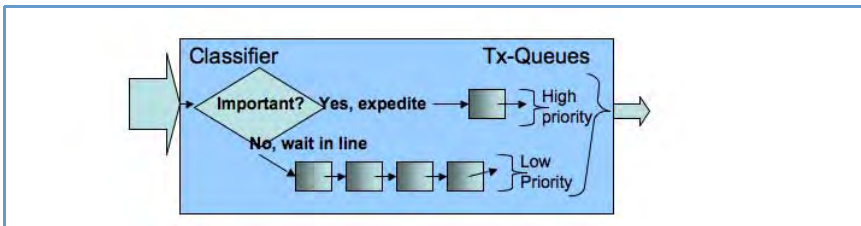

Figure 2. Illustration of classification and transmit queue in a simple high/low priority scheme. Low priority may transmit only when high priority is completely empty.

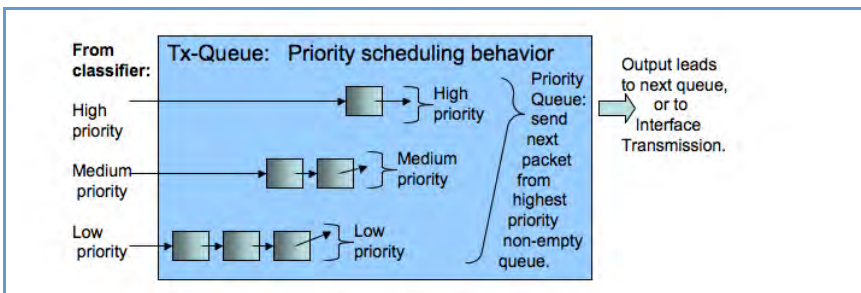

Figure 3. Illustration of priority scheduling

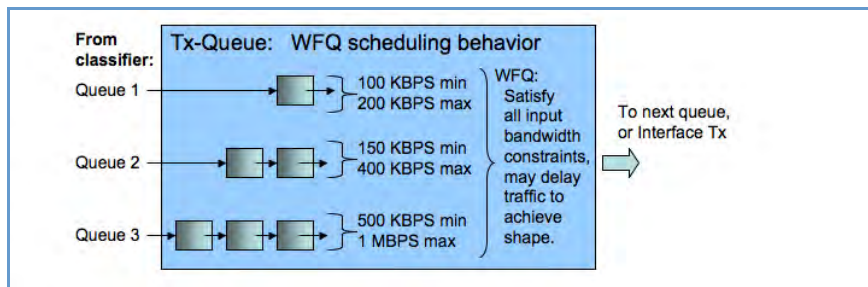

Figure 4. Illustration of weighted fair queue scheduling

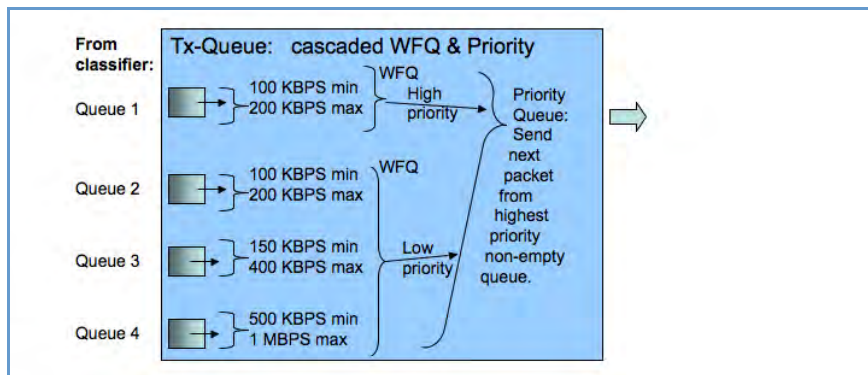

Figure 5. Illustration of a hybrid queue that is both priority and WFQ, to both constrain bandwidth usage and expedite one of the queues.

After the packet has been classified, it can be put in the proper queue. Queues are assigned to interfaces and can be constructed of several queue components to deliver the desired behavior.

Downstream QoS: Ethernet Switch

The simplest way of handling downstream QoS (from WAN to LAN) is to use the per-port queues that are present in the Ethernet switch. This achieves the greatest efficiency since the queues are handled in the switch hardware, and should be used when a strict priority queue with 4 priorities is sufficient.

The traffic is classified by priority-bit value. This can be the value retained from WAN ingress (assuming WAN is tagged,) or it can be a value that is set via a filter rule, which allows for advanced classification criteria to be used. Even though the LAN interface might not be tagged, there is still an internal priority field which is used to convey this information to the switch.

Downstream QoS: Egress queues

The secondary method of downstream QoS is to assign egress queues to the LAN port configuration. This is less efficient, however it allows more advanced queue scheduling algorithms to be used. Packets are classified by QoS markers set by filter rules.



This method is typically not recommended for deployment configuration as this mechanism can consume a large amount of CPU processing bandwidth.

Index

Symbols

!! command [108](#)

A

Access Code [28](#)

Address resolution table [115](#)

Administrator password [107](#)

Arguments, CLI [119](#)

ARP

 Command [109](#), [118](#)

B

Broadband Status [32](#)

Broadband Status Notification [88](#)

C

Call Statistics [54](#)

Captive Portal [209](#)

CLI [103](#)

 !! command [108](#)

 Arguments [119](#)

 Command shortcuts [108](#)

 Command truncation [119](#)

 Configuration mode [119](#)

 Keywords [119](#)

 Navigating [119](#)

 Prompt [108](#), [119](#)

 Restart command [108](#)

 SHELL mode [108](#)

 View command [120](#)

Command

 ARP [109](#), [118](#)

 Ping [110](#)

 Telnet [117](#)

Command line interface (see CLI)

CONFIG

 Command List [106](#)

Configuration mode [119](#)

Connection commands [122](#)

Custom Service [71](#)

D

Default Server [77](#)

designing a new filter set [61](#)

Device Access Code [22](#)

Device List [25](#)

DHCP lease table [111](#)

Diagnostic log [111](#), [116](#)

Diagnostics [80](#)

Documentation conventions [8](#)

Downstream QoS [216](#)

E

Ethernet statistics [111](#)

Event Notifications [88](#)

F

filter

 parts [61](#)

 parts of [61](#)

filter sets

 using [62](#)

filters

 using [61](#), [62](#)

firewall [115](#)

Firewall Advanced [78](#)

Firewall Status [58](#)

G

Global Filterset [129](#)

H

Help [24](#)

Home Network [37](#)

I

ICMP Echo [110](#)

IGMP [140](#)

IGMP Snooping [141](#)

IGMP Stats [35](#)

IP DNS commands [140](#)

IP Gateway commands [133](#)

IP IGMP commands [140](#)

IP interfaces [115](#)

IP Passthrough [75](#)

IP routes [115](#)

IPMap table [115](#)

K

Keywords, CLI [119](#)

L

LAN Ethernet Statistics [39](#)

LAN Host Discovery Table [115](#)

LEDs [13](#)

Link commands [144](#)

links bar [24](#)

Log [116](#)

Logging in [107](#)

Logs [83](#)

M

MAC Filtering [46](#)

Management commands [147](#)

Memory [116](#)

N

NAT Pinhole commands [154](#)

NAT Table [89](#)

NAT/Gaming [69](#)

NSLookup [81](#)

NTP commands [143](#)

P

Packet Filters [60](#)

Password

Administrator [107](#)

User [107](#)

Physical interfaces commands [151](#)

Ping [81](#)

Ping command [110](#)

Prompt, CLI [108](#), [119](#)

Q

QoS [213](#)

Quality of Service [213](#)

R

Redirect page [21](#), [150](#), [151](#)

Reset Connection [86](#)

Reset Device [86](#)

Reset IP [86](#)

Resets [86](#)

Restart [86](#), [112](#)

Restart command [108](#)

Restart Modem [31](#)

S

Safety Instructions [12](#)

Security

filters [60](#)

Session Initiation Protocol [157](#)

SHELL

Command Shortcuts [108](#)

Commands [108](#)

Prompt [108](#)

SHELL level [119](#)

SHELL mode [108](#)

show config [112](#)

Show ppp [118](#)

SIP [157](#)

Step mode [120](#)

Subnets & DHCP [48](#)

Supported Games and Software [72](#)

Syslog [87](#)

System commands [169](#)

System Information [27](#)

T

tab bar [24](#)

Targeted Ad Insertion [167](#)

Telnet [107](#)

Telnet command [117](#)

Test Web Access [81](#)

TFTP server [110](#)

Traceroute [81](#)

Trivial File Transfer Protocol [109](#)

Troubleshoot [80](#)

Truncation [119](#)

U

Update [85](#)

Upstream QoS [216](#)

User name [107](#)

User password [107](#)

V

View command [120](#)

view config [117](#)

Voice [52](#)

Voice-over-IP [157](#)

VoIP [157](#)

W

WiFi-Key [44](#)

Wireless [41](#)

Wireless Security [44](#)



ARRIS® Mobility DSL Gateways

ARRIS Mobility LLC
600 North U.S. Highway 45
Libertyville, Illinois 60048 USA
Telephone: +1 847 523 5000

December 6, 2013



