

# RDC-1 Recessed Door Contact

The Recessed Door Contact is a small Door Contact that is installed within door frame and door and concealed for protection. The Door Contact monitors door opening / closing. When the door opens, the magnet moves away from the Door Contact, causing the Door Contact to transmit door open signal to the Control Panel. When the door closes and the Door Contact detects magnet again, it will transmit a door close signal.

## ● Identifying the parts

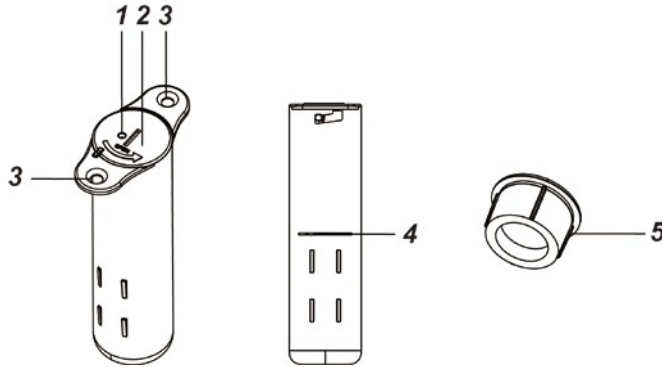

### 1. Learn / Test Button

(Press the button with a sharp pointed tool such as paper clip)

- Press the Test button to transmit a learn code.
- Press the Test button once to enter Test Mode for 3 minutes.

### 2. LED Indicator

### 3. Mounting Holes

### 4. Battery Insulator

### 5. Magnet Sensor

## ● LED Indicator

In Normal operation mode, the LED indicator remains off except in the following situations:

- When the Door Contact is activated under Low battery condition.
- When the Door Contact is activated under Test mode.

## ● Supervision

- The Door Contact will automatically transmit Supervisory signals to the Control Panel at random intervals of 30 to 50 minutes in Normal Operation Mode.
- If the Control Panel has not received the signal from the Door Contact for a preset period time, the Control Panel will indicate that particular Door Contact is experiencing an out-of-signal problem.

## ● Battery

The Door Contact uses one **3V CR2 Lithium battery** as its power source. It is also capable of detecting low battery. When the battery is low, a low battery signal will be sent to the Control Panel along with regular transmission. The LED will light up when the Door Contact is activated under low battery status. **When battery is exhausted, the Door Contact will stop all function and the LED will flash every 4 seconds.**

The battery is pre-inserted with a battery insulator. Pull out the battery insulator to activate battery.

### ● How to change battery:

1. Open the top cover with a flathead screwdriver, turning anti-clockwise indicated by the open arrow.
2. Withdraw the internal component and remove the old battery.
3. After removing old battery, press Learn/Test button a couple times to fully discharge before inserting new battery.
4. Align the Reed Switch on the PCB with the marking on the casing, and then insert the internal component back to the casing.
5. Close top cover and turn clockwise by using the flathead screwdriver until the latch mark align.

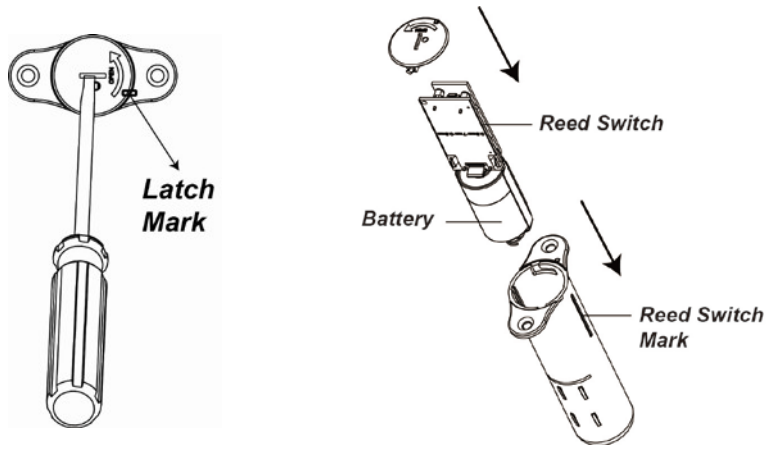

## ● Test Mode

The Door Contact can be put into Test mode for 3 minutes by pressing the Test Button using a sharp tool. During Test mode, the LED will turn on briefly upon triggering. Each press on the Test Button, the Door Contact will transmit a test signal to the Control Panel for radio range test and resets the test mode back to the 3-minute duration. It will exit Test Mode automatically after the 3 minutes and returns to Normal Operation mode.

## ● Getting Started

1. Pull out the battery Insulator.
2. Put the Control Panel into learning mode; refer to Control Panel manual for detail.
3. Press the Test Button using a sharp tool on the Door Contact to send signal to the Control Panel.
4. Refer to your Control Panel manual to complete the learning process.
5. After the Door Contact is learnt in, put the Control Panel into "Walk Test" mode. Hold the Door Contact at the desired location, and press the Learn/Test button to confirm if this location is within signal range of the Control Panel.
6. When you are satisfied with the Door Contact at the chosen location, proceed to **Installation & Mounting Procedure**.

## ● Installation

- Avoid mounting the Door Contact near metal objects, such as door lock, metallic door frame that could possibly cause magnet to malfunction.
- When mounting the Door Contact and the Magnet, make sure both of them align to each other to allow optimal opening/closing detection.
- The distance between the Door Contact and magnet when the door is closed should be no more than 12.7mm.

## ● Mounting Procedure

The following description and picture shows how the Door Contact and the Magnet should be mounted. Please follow the steps below to start mounting your Door Contact (make sure the battery insulator is removed):

1. Use a 19mm drill bit to drill a 70mm deep hole into your door frame for Door Contact main body.
2. Use a 19mm drill bit to drill a 15mm deep hole into your door for the magnet.
3. Insert the Door Contact main body into the door frame drill hole and tighten with screws through the mounting holes using a screwdriver.
4. Insert the Magnet firmly into the drill hole on the door. Installation is now complete.

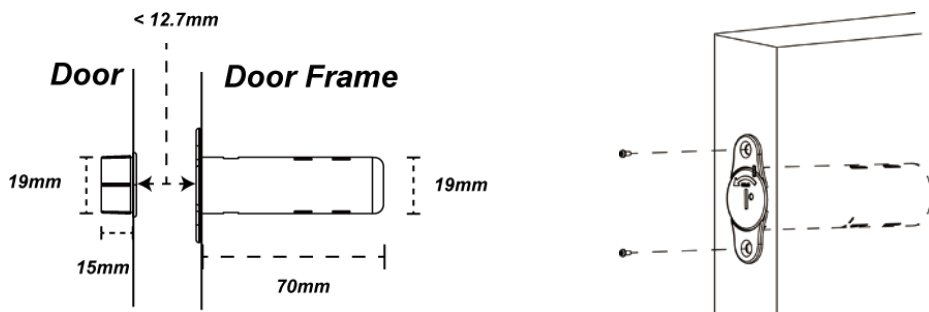

This device complies with Part 15 of the FCC Rules. Operation is subject to the following two conditions:

(1) This device may not cause harmful interference, and

(2) This device must accept any interference received, including interference that may cause undesired operation.